

# ***dynaco*** **STEREO 416**

SERIAL NUMBER

This number must be mentioned in all communications concerning this equipment.

## **INSTRUCTIONS FOR ASSEMBLY OPERATION**

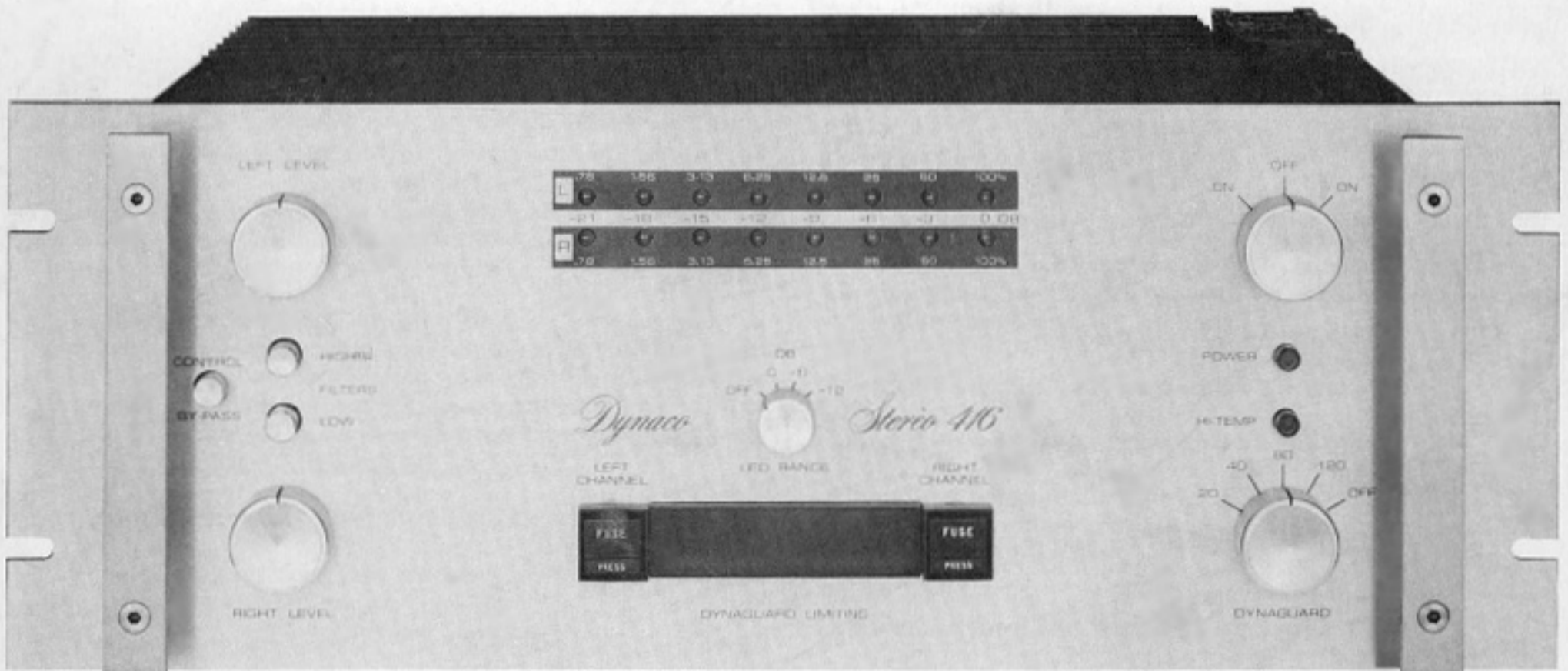

***dynaco inc.***

COLES ROAD & CAMDEN AVENUE / POST OFFICE BOX 88  
BLACKWOOD, N. J. 08012, U.S.A.

Bob1005@aol.com

## CONTENTS

<p>Specifications ..... 2</p> <p>Operating Instructions ..... 3</p> <p>  Installation ..... 3</p> <p>  Connections ..... 3</p> <p>  Controls ..... 4</p> <p>  Operation ..... 5</p> <p>    Dynaguard ..... 5</p> <p>    Relay Operation ..... 5</p> <p>    LED Indicators ..... 6</p> <p>    Loudspeaker Ratings ..... 6</p> <p>    Output Fuses ..... 6</p> <p>    Monophonic Operation ..... 7</p> <p>    Fan Cooling ..... 7</p> <p>Assembly Instructions ..... 7/28</p> <p>Schematic Diagram ..... 20/21</p> <p>Component Values ..... 22/23</p>	<p>Preliminary Tests ..... 28</p> <p>Technical Information ..... 29</p> <p>  In Case of Difficulty ..... 29</p> <p>  Technical Service Information ..... 30</p> <p>  Performance Testing ..... 30</p> <p>  Square Wave Performance ..... 31</p> <p>  Circuit Description ..... 32/34</p> <p>  International Transformer Wiring ..... 35</p> <p>  Circuit Board Layouts ..... 36/37</p> <p>  Voltage Test Points ..... 36/37</p> <p>  Dynaguard Characteristics ..... 38</p> <p>Warranty and Service Policies ..... 39</p> <p>Kit Parts List ..... 40</p> <p>Pictorial Diagram ..... Insert</p> <p>Photographs ..... Insert</p>
--	--

**WARNING: TO PREVENT FIRE OR SHOCK HAZARD, DO NOT EXPOSE THIS EQUIPMENT TO RAIN OR MOISTURE.**

## SPECIFICATIONS

### Power Output Ratings:

Less than 0.25% total harmonic distortion at any power level up to 200\* watts continuous average power per channel into 8 ohms (300\* watts per channel into 4 ohms; 100\* watts per channel into 16 ohms) at any frequency between 20 Hz and 20 kHz with both channels driven. Distortion reduces at lower power levels.

### Power at Clipping, Single Channel, 2500 Hz, less than 1% distortion:

235 watts @ 8 ohms; 350 watts @ 4 ohms; 450 watts @ 2 ohms; 135 watts @ 16 ohms.

### Intermodulation Distortion:

Less than 0.1% at any power level up to 200 watts rms per channel into 8 ohms with any combination of test frequencies. Distortion reduces at lower power levels.

### Half-Power Bandwidth:

100 watts per channel at less than 0.25% total harmonic distortion from 5 Hz to 35 kHz into 8 ohms.

### Frequency Response:

+0, -1 dB, 8 Hz to 50 kHz @ 1 watt into 8 ohms.  
±0.5 dB, 20 Hz to 20 kHz @ 200 watts.

### Hum and Noise:

Greater than 95 dB below rated output, full spectrum;  
Greater than 100 dB below rated output, 20 Hz—20 kHz.

### Input:

Normal: 50,000 ohm load; Control By-Pass: 20,000 ohm load;  
1.6 volts for 200 watts @ 8 ohms.

### Slewing Rate:

8 volts per microsecond.

### Damping Factor:

Greater than 80 to 1 kHz into 8 ohms;  
Greater than 30 to 10 kHz into 8 ohms.

### Channel Separation:

Greater than 60 dB by IHF standards.

### Connectors:

Inputs: phono jacks. Outputs: color coded 3-way binding posts with standard 3/4" spacing.

### Dimensions:

19" wide; 14" deep; 7" high.

### Weight:

Shipping weight 59 lbs./27 kilos. Net weight 53 lbs./25 kilos.

### Power Consumption:

120 v.a. quiescent; 17 amps maximum; 50/60 Hz, 120 vAC.

\*Measured in accordance with the Federal Trade Commission's Trade Regulation rule on Power Output Claims for Amplifiers.

## TYPICAL PERFORMANCE CURVES

To arrive at "typical" curves, four channels were evaluated on all bases. In each case, the curve shown is the next-to-the-worst of the four. Therefore, do not expect exact correlation between curves.

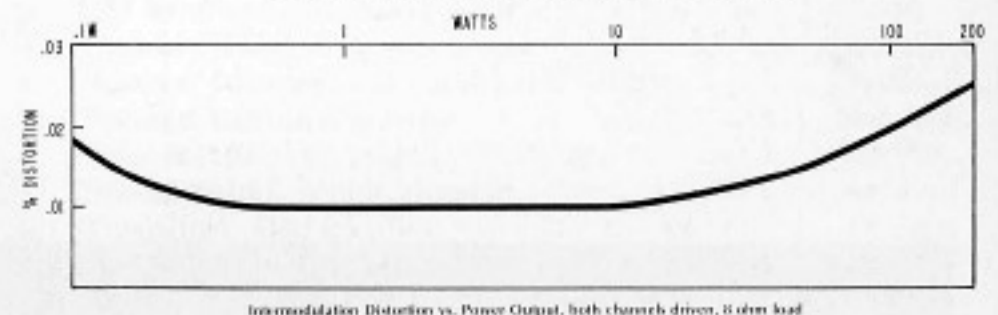
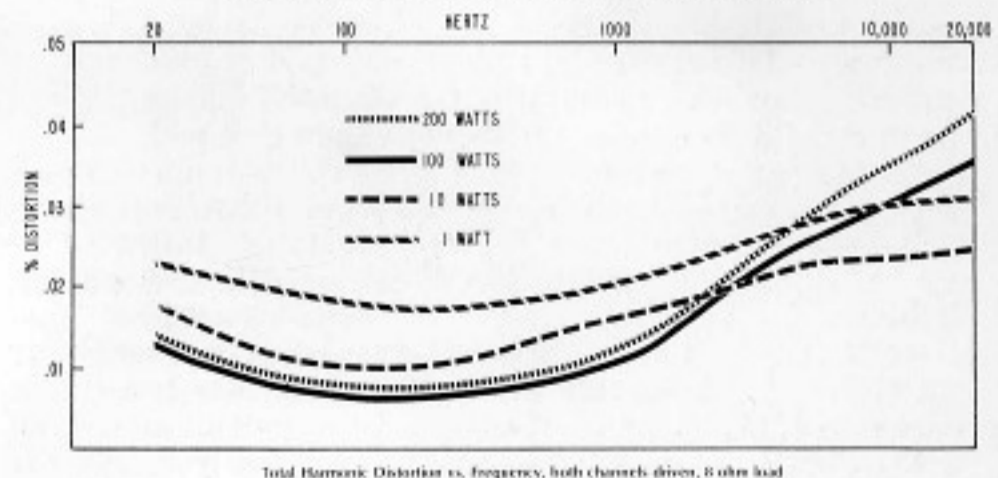
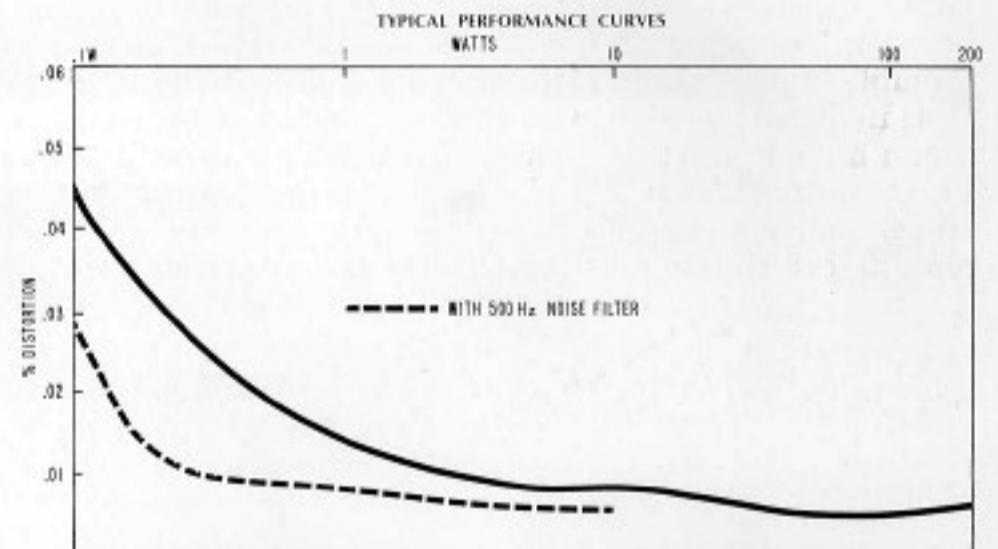

IT IS ESSENTIAL THAT YOU READ AND UNDERSTAND THE OPERATING INSTRUCTIONS BEFORE YOU CONNECT YOUR STEREO 416. ANY AMPLIFIER WITH THE POWER OUTPUT CAPABILITY OF THE STEREO 416 IS ABLE TO DAMAGE ALMOST ANY LOUDSPEAKER IF IT IS IMPROPERLY USED.

**Dynaco is not responsible for damage to the load (loudspeaker) as a result of excessive or improper input signals and resulting high power output.**

## INTRODUCTION

The Dynaco Stereo 416 is a basic power amplifier employing all silicon semiconductors. They include 70 transistors, 51 diodes, 16 light emitting diodes, 2 silicon controlled rectifiers, and 8 integrated circuits. The series-parallel connection of 8 output transistors per channel is of full complementary symmetry design. The entire main amplifier is direct coupled. Its measured distortion levels approach the threshold of the most exacting laboratory test equipment, not only at the commonly specified full power ratings, but more importantly at very low power outputs as well. This is the result of circuit techniques which eliminate any discernible crossover notch at low levels, and it contributes in large measure to the Stereo 416's freedom from listening fatigue. Its lucid, utterly uncolored neutrality reveals delicate nuances and musical shadings in the best program material—one result of achieving unconditional stability with varying loudspeaker loads.

Implicit in the design of a superb high power amplifier is the responsibility to include superior techniques of protection for both the amplifier and the speaker load, if long-term trouble free operation is to be achieved. To this end, Dynaco has included more separate protective systems and features than have ever been employed in such a product.

These include an AC line circuit breaker (rather than a fuse); four separate power supply fuses; electronic volt-amp limiting to ensure safe operation of the output transistors;

independent high temperature cutouts on each channel, which are mounted directly on the output transistors to assure maximum sensitivity; over 1000 square inches of radiating area for the mammoth heat sink; two speed fan cooling for optimum efficiency; delayed turn-on to eliminate loudspeaker thumping; relay protection against DC signals at the output; load (speaker) protection fuses accessible on the front panel; input level controls to reduce sensitivity; input filters to control the bandwidth; the exclusive DYNAGUARD™ adjustable dynamic power limiting circuit to protect the speaker load; and a switch to by-pass the level controls, filters and Dynaguard.

The Stereo 416 was engineered to accommodate a wide range of specialized needs in studio, laboratory and industrial applications, as well as in the home. It has been designed as two independent 200 watt (at 8 ohms) amplifying channels with a common power supply having a high degree of inherent regulation. For special requirements, a technician can easily convert it to a monophonic 600 watt (at 8 ohms) output.

The front panel with handles is designed for mounting in a standard 19" rack, and Light Emitting Diodes with range switch provide accurate readout of power. An alternative power transformer for international AC line voltages, and an accessory C-100 Energy Storage System, are available at additional cost.

## OPERATING INSTRUCTIONS

### INSTALLATION

The Stereo 416 should be located where the front panel power switch is convenient, since control preamplifiers do not normally include the requisite heavy-duty switching. If the amplifier is to be mounted near a phono cartridge, you should check to be sure the cartridge does not pick up hum from the power transformer. Convenient as it may appear the amplifier heat sink is *NOT A RECORD RACK*. Nothing should be placed on top of the unit. In addition to the finned heat sink, it is normal for the perforated cover to get warm behind the power switch and over the PC-28 circuit boards.

*VENTILATION* is an important consideration with any amplifier of this size. Although solid state units do not generate the high heat expected from tube designs at normal output levels, they can be limited by excessive heat buildup. Further, solid state designs generate their maximum heat output at less than half power. Thus *ADEQUATE AIRCIRCULATION IS ESSENTIAL*. The Stereo 416 puts out the heat of a 100 watt lamp under quiescent (no signal) conditions, and several hundred watts of heat at high power levels. The massive heat sink has more than enough cooling capacity for any music and speech signals—even at very high powers—if fresh air flow under the chassis and at the fan opening are unrestricted.

The Stereo 416 is intended to be installed horizontally or vertically, with its feet providing clearance for air flow under the unit. Do not allow the ventilation holes in the bottom to be restricted (don't place the amplifier on a rug, for example).

If you wish to mount the amplifier through a cabinet panel, a cutout  $6\frac{1}{2}'' \times 16\frac{5}{8}''$  is suggested. Remove the feet for front mounting access. A supporting shelf flush with the bottom of the cutout must include an opening for the chassis vents.

The panel dimensions of  $7'' \times 19''$  fit a professional rack mounting standard. Hardware to mount the Stereo 416 in a rack is #10-32 (not supplied).

### CONNECTIONS

#### AC Power

The power cord should be plugged into a 3-wire grounded *wall outlet* providing 120 volts, 50/60 Hz on a 15 amp (minimum) circuit. If a matching outlet is not available, an adapter with separate ground wire may be obtained locally. Be sure to secure its green ground wire to the center screw of

the *wall outlet* plate. In most instances this ground wire should *not* be attached to the preamplifier chassis. If a longer power cord is needed, use a 3-wire cable of the type specified for air conditioners.

Do *not* attempt to switch the amplifier remotely by plugging it into a switched outlet on a control preamplifier unless the outlet is designated as a 12 amp (1400 watts) or higher capacity. *Most preamps are not normally designed to handle the high current switching.* Dynaco's PAT-5 and PAT-5 BI-FET are exceptions.

## Input

Signal input connections are via shielded cables to conventional phono jacks on the rear panel, under the heat sink. Channel A is designated the left channel; B the right. The amplifier's nominal input load impedance is 50,000 ohms. The input sensitivity is 1.6 volts for full output. The Stereo 416 may thus be easily driven by control preamplifiers such as the Dynaco PAS-3X, PAT-4 or PAT-5. Dynaco tube type preamplifiers made before 1966 require an internal modification, details of which will be supplied by Dynaco on request. Some other tube type preamplifiers may require modification for optimum performance into a 50 K ohms load.

It is desirable to keep the left and right input cables close together throughout their run to avoid extraneous hum.

## Output

Select output leads of sufficient size to preserve the outstanding performance capabilities of your amplifier. HEAVY GAUGE #16 lamp cord ("zip cord") is suitable for distances up to 20 feet with an 8 ohm load. Larger wire size is necessary for longer distances—#14 for 30 feet; #12 for 50 feet. #16 lamp cord is available from hardware stores; #14 and #12 twisted cable may be obtained from electrical supply houses. For a 4 ohm load, these maximum distances should be cut in half.

Connect the left speaker to Channel A output terminals. Be sure to maintain similar wiring "sense" for each speaker, so that they will be connected *in phase*. Normally the (-), common, or ground terminal of each speaker is connected to the black amplifier terminal. Proper phase sense is easily maintained with lamp cord because one conductor is coded with a molded ridge on the outer insulation, or different color conductors are used.

Two speakers are connected in phase when maximum low frequency output is heard when they are driven from a monophonic source. Lowered output is observed when the connection to one of the speakers is reversed (out of phase, or reversed polarity). When using multiple speakers on each channel, or when 4 channel systems are used, it is important that all of the speakers in the same area be wired in phase.

The amplifier terminals are 3-way binding posts which will accept single or double "banana plugs", spade lugs, or simply stranded wire. If stranded lamp cord is used, the wire ends should be "tinned" with solder first to avoid fraying. To connect the wire, unscrew the terminal cap until the vertical hole through the metal shaft is uncovered from below, push the wire end through the hole, and tighten the cap.

Make certain that no wire strands can touch other than the intended terminal. Double banana plugs (from radio supply houses) are the most convenient connectors, and are simply inserted into the ends of the terminals. They are particularly useful if a second set of speakers is to be connected in parallel, as they plug into one another.

The 200 watts per channel rating of the Stereo 416 is based on a load impedance of 8 ohms. Loudspeakers with impedances of 2 to 16 ohms may be utilized. Power output increases with decreasing impedance, producing 450 watts per channel at 2 ohms. If the load impedance falls below 2 ohms, the volt-amp limiting of the amplifier will protect the output.

The black "common" output terminals are electrically connected internally. They are also connected to the chassis, so the Stereo 416 may be used with special output connections which require common grounds. You must be *certain* that the polarity of such output connections is never reversed, however, so that the red "hot" terminals can never be connected together in other equipment.

## CONTROLS

The power switch lights the pilot lamp when turned to either "on" position. The choice enables you to reverse the polarity of the line cord in case a hum loop is evident.

In most instances the input level controls will both be turned fully clockwise for maximum sensitivity. You may wish to reduce the setting of these controls to prevent excessive signals from overdriving the speakers if the preamplifier volume should be turned fully up. However, such operation may result in somewhat higher noise level from the preamplifier.

Input filters are provided for 50 Hz and 15 kHz (-3 dB points) low and high frequency rolloff. These are engaged when the button is "in".

Dynaguard is a switchable dynamic power limiter circuit for speaker protection. The numbers indicate the average power output per channel into 8 ohms at which the circuit will function to limit the output. When that threshold is reached, an overload lamp is lighted behind the dark plastic window, adjacent to that channel's output fuse. The circuit then begins to limit the output to protect the speaker. For most speakers, the lowest switch position (20) is recommended.

A control by-pass switch connects the audio directly to the driver boards. When this switch is "in" the input level controls, input filters and Dynaguard are by-passed.

The range of the LED readout is adjusted by a 4-position switch under the LED bank. The operation of the LED indicators and the attenuator switch are described fully on page 6.

The lighting of the Hi-Temp lamp indicates that a thermal sensor has shut off the amplifier. Normal operation will resume automatically when the output transistors cool below the limit threshold. Continued operation at the same signal levels may again actuate the protective cutout.

The Stereo 416 provides speaker protection fuses on the front panel. The amplifier is supplied with 5 ampere 3 AG types. This size is necessary for final testing, and provides NO PROTECTION for any speaker. A pair of 1 ampere, regular fast acting types are separately provided for speaker protection. *You should install them now.* Use a higher value only if it is recommended by the manufacturer of your speakers. Some speakers even specify a smaller amperage for safety. Be sure to obtain spares of the proper value, and keep them handy.

Press down and inwards on the lower section of the fuse plate to release it. Reinstall it by pressing inwards and slightly *up* on the *top* half of the plate. Be sure it is fully seated.

## OPERATION

When you turn on the amplifier there is a delay before the relay connects the speakers. This eliminates annoying (and potentially harmful) high power onset thumps through the speakers. The relay also provides clean shutoff, without decaying transients.

*You should turn the power amplifier on last, and off first.* No damage will ensue if you do not, but otherwise DC level changes in other related equipment may cause the relay to click annoyingly.

For maximum speaker protection, the 20 watt (at 8 ohms) position of the Dynaguard selector is recommended. This will not have any effect on normal listening, and short duration peaks of much higher levels may pass without any restriction. Only if the composite signal sustains an average level greater than the switch setting for a finite time period will the overload lamp glow, and the limiting action take effect. Read the following explanation of Dynaguard, and know your speaker's power capabilities before switching to any higher threshold level. In the "off" position, no Dynaguard protection is afforded.

The input filters will find greater use in public address and musical instrument applications than in home music systems. Since they are intended to function only at the frequency extremes, the effect of these filters will not be obvious. The high filter may help to eliminate certain interference effects with the smallest limitation on absolute quality. Under exceedingly high drive conditions, the use of these filters may afford greater amplifier power reserve and added speaker protection by reducing potential overloading signals above and below the audio range.

The Stereo 416 includes circuits to protect against the hazards of shorted and open circuited outputs, and abnormal load demands, even at full power. Good operating practice will avoid the need to test their effectiveness, however, for there is no such thing as absolute protection from abuse.

The combination of enormous power potential and the relative fragility of most high quality sound reproducers makes it imperative that you take care to avoid such common faults as dropping a stylus (tone arm) onto the record; allowing the arm to skid across the record; or flicking the stylus clean with your finger while the volume is up. These are typical errors which generate heavy low frequency pulses capable of severely overdriving the speaker at subsonic frequencies before any protective system can engage.

### Dynaguard

This new approach to speaker protection is not nearly so restrictive as a limiter, and does not suffer the reduction in dynamic range or the "breathing" characteristics of compressor circuits. And, it signals its protective operation. The assumption is made that any speakers used with such an amplifier can accommodate frequent peaks well above their nominal power ratings for short intervals. The threshold power (per channel) for an 8 ohm load is marked on the panel. A 16 ohm load cuts each marked power level in *half*. A 4 ohm load *doubles* each figure.

Dynaguard has absolutely no effect on distortion, frequency response or output level until its triggering threshold is reached. Then it functions as a dynamic power limiter. It senses the integrated power output separately on each channel. When that reaches the selected level, lighting the overload lamp, the limiting action commences. At lower levels a graduated power/time relationship regulates the

duration of the permissible overdrive as a function of the wave form and degree of overdrive. Thus it passes very short peaks up to amplifier clipping, and longer duration peaks of intermediate powers, so long as the average power level is substantially below the set threshold. The overdrive headroom is curtailed as the integrated power output rises.

For typical music signals and high accuracy loudspeakers only the 20 and 40 positions offer significant protection. The 80 and 120 settings are of value chiefly in industrial or laboratory applications. The dynamic range of any quality musical program material is such that peaks 10 dB above average levels are common. A peak 8 dB above 40 watts will exceed the amplifier's maximum power. Such peaks will thus be limited before the overload lamp glows in the 40 position. Any overload lamp indication at 80 or 120 on musical signals demonstrates the need for a *much* larger amplifier, such as Stereo 416 wired for monophonic 600 watt output, and additional speakers.

The overload lamp may flicker just below the threshold at which protective signal limiting commences. A second or so after the lamp glows steadily with severe overdrive, you will hear increased distortion and a drop in level as full limiting takes effect. This loss of level is simply a function of the truncated waveform, not of any circuit gain change. There is no difference in nominal gain in the different Dynaguard settings.

The circuit does not latch, but it may give that appearance because limiting is continued until the integrated signal level drops below the threshold and the lamp extinguishes. There is zero breathing effect, and the maximum envelope delay is less than 5 seconds for the entire cycle.

IT IS NORMAL FOR THE DYNAGUARD LAMPS TO LIGHT BRIEFLY WHEN THE AMPLIFIER IS TURNED ON.

### Relay Operation

The primary purpose of the relay is to disconnect the load if potentially destructive signals or equipment malfunction imposes direct current on the output. The relay control circuits are triggered independently from each channel, but both are shut down concurrently. They are designed to trip even with equivalent out-of-phase offset signals in each channel, and sense both positive and negative deviations.

The relay control circuit parameters are factory set to provide substantial protection, based on the premise of good quality signal inputs. The DC threshold is nominally 1.5 volts. Since subsonic signals appear similar to DC at high power levels, the relay may trip as a result of signals you previously did not know existed. Likewise, severe overload at the output will appear similar to DC, and thus may actuate the relay.

You may wish to increase the sensitivity of the relay circuit, particularly if you use speakers which may be easily damaged by excessive signals. See the section "Momentary Sound Interruption" on page 30 for details.

Attention paid to input signal quality will avoid a major cause of speaker failure with high power amplifiers. Some of these signals are not audible. Warped records, acoustic feedback, excessive rumble, FM muting effects, switching transients, and even the operation of some controls can all present signals for which the relay is designed to trip, to protect the speaker. Thus relay operation under such conditions is not a malfunction, but instead indicates that other measures may be able to reduce the problem at the source. Even the best of FM muting circuits may trip the relay at certain dial traversing speeds. Often moving a control or selector switch more deliberately will avoid the effect.

## LED Indicators

A group of 8 Light Emitting Diodes (LEDs) per channel serve to accurately monitor the output signal voltage. 16 one-bit analog/digital converters signal the LEDs on or off; they are never half-lighted. The diodes are calibrated in RMS, but they are PEAK RESPONDING. Each LED responds to a single cycle of information, even at 20,000 Hz. The circuit permits the diode to remain lighted long enough for the information to register on the eye. Thus the action precisely indicates the magnitude of transient waveforms which are the substance of music. By responding to peaks, the eye can observe even brief musical transients—typically 10 to 20 decibels (dB) above the average or RMS levels monitored by conventional meters or LEDs.

An attenuator switch adjusts the input level to the LED indicators, three positions plus off, and calibrated in dB. The 0 dB position is the least sensitive, and -12 dB the most sensitive. Although it is not possible to "overload" the LED indicators, the 0 dB position should be used where anticipated power levels are not known, and when beginning any tests. Once the playback levels have been established, switch to the position yielding the most information.

The chart below lists 8 ohm load power outputs in watts for each attenuator switch position, and corresponds to the percentage (%) and dB markings on the front panel for the LEDs. For a 4 ohm load, the wattage should be doubled; for a 16 ohm load, the wattage should be halved. When the amplifier is wired in bridge mode for mono use, both left and right LEDs will light similarly for a given power reading, and the power indicated by them should be multiplied by 4 for an 8 ohm load.

Panel Markings	Attenuator Range		
	0 dB	-6 dB	-12 dB
100% (0 dB)	200	50	12.5
50% (-3 dB)	100	25	6.25
25% (-6 dB)	50	12.5	3.13
12.5% (-9 dB)	25	6.25	1.56
6.25% (-12 dB)	12.5	3.13	0.78
3.13% (-15 dB)	6.25	1.56	0.40
1.56% (-18 dB)	3.13	0.78	0.20
0.78% (-21 dB)	1.56	0.40	0.10

## Loudspeaker Rating Considerations

Nominal speaker power ratings are a matter of concern. There is currently no U.S. standard. Manufacturers usually provide a "music power" rating, or indicate amplifier power limits. These should not be confused with continuous, or "rms" power acceptance for a sustained period, which will be substantially lower. It is rare for a speaker to be able to handle as much power near the frequency extremes as in the midrange. Single woofer high fidelity speaker systems rarely have "music" ratings as high as 100 watts, or continuous duty wide band sine wave ratings as high as 40 watts.

In view of the power limitations of most high accuracy speaker systems, the connection of two or four similar speakers in the same location to a single channel is often advisable with high power amplifiers. Lacking more definitive advice, a rough test is to place your hand in front of the woofer when playing a loud passage at your anticipated listening level. If you can feel *any* heat generated by the voice coil, you should consider the need for additional speakers to reproduce that level safely. When high output, high accuracy reproduction is desired, a series-parallel connection of four 8 ohm speakers (such as the Dynaco A-30XL) on each channel provides a resultant 8 ohm load with exceptional power handling capacity.

Speaker impedance varies with frequency—often by a factor of 4 or 5 to 1. Even the least variable speakers have a 2:1 change. While most nominal ratings are close to the actual minimum impedance, when combinations approach the 2 ohm minimum recommended amplifier load, the safest procedure is to measure the resistance across the terminals with an ohmmeter. Speaker impedance usually varies upwards from this value. Use this figure to determine whether multiple speakers (on each channel) should be connected in parallel:

$$\begin{aligned} 2 \times 8 \text{ ohms} &= 4 \text{ ohms} \\ 2 \times 16 \text{ ohms} &= 8 \text{ ohms} \\ 4 \times 16 \text{ ohms} &= 4 \text{ ohms} \end{aligned}$$

$$\begin{aligned} \text{or in series: } 2 \times 4 \text{ ohms} &= 8 \text{ ohms} \\ 2 \times 8 \text{ ohms} &= 16 \text{ ohms} \\ 4 \times 4 \text{ ohms} &= 16 \text{ ohms} \end{aligned}$$

These simple examples assume identical models. It is not wise to connect dissimilar speakers in series because of adverse audio effects.

## Output Fuse Protection

Why are both Dynaguard and speaker fuses provided? We realize that some users will switch off Dynaguard despite our advice. And most users tend to use too large a fuse so as to avoid the annoyance of a blown fuse when you lack a spare. A fuse provides a slow-acting, but nonetheless final measure of protection with different characteristics than Dynaguard. You can choose its value to have either or both protective systems, or virtually none at all if Dynaguard is switched off.

Since the power passed by a fuse varies with load impedance, and test signals have little correlation to music signals, and fuses vary in their tolerance of music overloads, the protective rating determination for a speaker is largely empirical. Logic would suggest the smallest value fuse which does not blow frequently at what are high, but nonetheless safe levels for your speaker. There are few speakers capable of safely handling more power than will blow a 2 ampere fuse.

The speaker manufacturer who specifies a fuse rating solves your problem. Lacking this, remember that a fuse will not blow until a *sustained* signal *well above* its rating is imposed for a time. A slo-blow fuse will allow appreciably more overdrive than the same value standard fastblow type, and is thus not generally recommended for speaker protection. There are also very fast-acting types usually used for instrument protection, but these are not as readily available.

The lowest Dynaguard setting is the practical limit for assured operation of the protection circuit, yet some speakers need protection sooner—as little as ½ ampere, or 4 watts for a 16 ohm speaker, if the fuse blows at its rating. Tests have

shown that musical signals which frequently cause the overload lamp to glow brightly in the minimum Dynaguard 20 position with an 8 ohm speaker will occasionally blow a 1 ampere regular fuse (nominally 8 watts). A 1 ampere slow-blow type did not blow. Peaks up to the full power of the amplifier were sometimes passed during these tests.

The chart below shows the highest *sustained* power level which will *not* blow the fuses shown. Remember that speaker impedance typically rises well above its nominal value. Experience suggests that on this basis power levels of 10 watts are safe starting points for most high fidelity speakers using a single woofer.

		SPEAKER IMPEDANCE		
		4 ohms	8 ohms	16 ohms
FUSE SIZE	1/2 ampere	1 watt	2 watts	4 watts
	3/4 ampere	2.2 watts	4.5 watts	9 watts
	1 ampere	4 watts	8 watts	16 watts
	1 1/2 ampere	9 watts	18 watts	36 watts
	2 ampere	16 watts	32 watts	64 watts

### Monophonic Operation

A single channel of the Stereo 416 may be operated at any time, provided there is no input signal to the unused channel. There is no need for any load resistor on the unused channel, as the design is completely stable.

*Never* connect the red output terminals together (in parallel) in an attempt to obtain higher output. Owing to speaker impedance variations, there is little benefit of useful power increase when paralleled, and there is a probability of damage to the amplifier. A simple solution for high power mono-

phonic requirements with multiple speakers is just to split the speakers between the two channels, and drive both with the same input signal.

For very high power requirements, an extra cost kit is available which provides 600 watts mono output at 8 ohms (800 watts mono at 4 ohms). This kit combines the two channels differentially and provides a floating (ungrounded) output between the two red output terminals. Information on this kit will be supplied by Dynaco on request.

The right channel level control and input are used for mono signals. The left input is disconnected internally. In such use, the Dynaguard power settings operate at 4 times the 8 ohm markings. Because of component tolerances, both Dynaguard overload lamps may not light simultaneously, but the circuit will function in accordance with the *right* (B output) lamp. The output fuses are connected in series. If one is of lower rating, its value governs the acceptable power into the load. If both are rated the same, it is wise to replace both if one blows.

Because of the nature of the volt-amp limiting protection which is a part of this amplifier, monophonic power output at impedances below 4 ohms drops off rapidly. Loads should be chosen which vary upwards from 4 ohms.

### Fan Cooling

The end of the heat sink is supplied with a very quiet 2-speed circulating fan for optimum air flow. Unless the amplifier is under test or is driven on speakers to unusually high powers at 4 ohms impedance or less, the fan will remain at low speed. The fan will automatically switch to high (normal) speed when the thermostat (on the *inside* rib of the heat sink) registers 55° C, and it will reduce to low speed when the temperature drops below that value.

## ASSEMBLY INSTRUCTIONS

The Stereo 416 is the most complex Dynakit, but it is relatively simple compared to other brands. The printed circuit boards have been preassembled and fully tested to save much of the work, and the assembly that remains is essentially point-to-point wiring. Work slowly and carefully instead of being concerned about time.

Construction will be greatly simplified if you have someone help you by reading the steps aloud, selecting the required parts, and preparing the necessary wire lengths as you proceed.

When you unpack your kit, check off the components against the parts list on page 40. Separate the hardware items in an egg carton or similar container. You can identify unfamiliar parts by checking them against the pictorial diagram, even though that drawing is necessarily somewhat distorted for visual separation.

Have the proper tools at hand before starting construction. The tools necessary are:

1. A pencil-type soldering iron with a 3/16" tip or smaller of 40 to 60 watts rating, with a tip temperature of 700 to 800° F.
2. A damp sponge or cloth to wipe the tip of the iron.
3. 60/40 rosin core solder not larger than 1/16" diameter.
4. A medium size screwdriver (1/4" blade).
5. Long nosed and diagonal cutting pliers.
6. Heavy "slip joint" pliers.
7. A single edged razor blade or inexpensive wire stripping tool for removing insulation.
8. Wood toothpicks

We do *not* recommend using a soldering gun. Not only can a gun provide more heat than is necessary—an unskilled user might damage printed circuit boards—but also many users tend to make poor solder connections, simply because they do not wait long enough for the gun to reach its operating temperature each time. Use a conventional pencil type iron.

A good solder connection does not require a large amount of solder around the joint. A well-made connection looks smooth and shiny because the solder *flows into the joint* when both parts are hot enough.

There are four steps to making a good solder connection:

1. Make a good mechanical connection.
2. Heat *both* parts with the tip of the iron *at the junction*.
3. Apply solder to the *junction* until it melts and flows.
4. Allow the connection to cool undisturbed.

ALL SOLDERING MUST BE DONE WITH A GOOD GRADE OF ROSIN CORE SOLDER.

Under no circumstances should acid core solder be used. Unmarked solder, cheap solder or any of doubtful origin should be discarded, and *separate solder fluxes should never be used*. The warranty is voided on any equipment in which acid core solder or acid type fluxes have been used. Silver solder is not suitable. The recommended solder is 60/40 (60% tin, 40% lead) ROSIN CORE. Do not confuse this with 40/60, which is harder to use.

You should realize that many of the more delicate components are less likely to be damaged in the soldering process if you use a hot iron for a short time, rather than a cooler iron for a longer period. You will also make a better connection with the hot iron. If you keep the iron clean by wiping the tip frequently, and occasionally add a small amount of solder to the tip, it will aid the transfer of heat to the connection. Do not allow too much solder to build up on the tip though, or it may fall onto adjacent circuitry.

One of the best ways to make a good mechanical connection is to bend a small hook in the end of the wire, and then to crimp the hook onto the terminal lug. The amount of bare wire exposed need not be exactly  $\frac{1}{4}$ -inch, but if it is too long, the excess might touch another terminal lug or the chassis. Do not wrap the wire around the lug more than one time, as this makes the connection difficult to remove if an error is made.

Many of the wiring steps will call for "preparing" a wire of a certain length and color. This involves cutting the necessary length of wire and stripping  $\frac{1}{4}$  inch of insulation from each end. This is most easily done with wirestrippers, but diagonal cutters can be used if you are careful not to nick the wire and weaken it.

When soldering a lead to a numbered, plated-through hole on a circuit board, push the lead through the hole first. *Do not push the wire all the way into the hole up to the insulation.* Apply the solder and the hot iron at the same time to the junction of the hole and lead. The solder should melt very quickly; it should flow easily and fully into the hole and completely around the lead. Remove the iron and allow the connection to cool. If in doubt of your connection, you may also wish to apply solder and iron to the hole and lead from the other side of the board. It is *essential* to have a smooth, shiny flow of solder from the lead to the plated circuitry on the board.

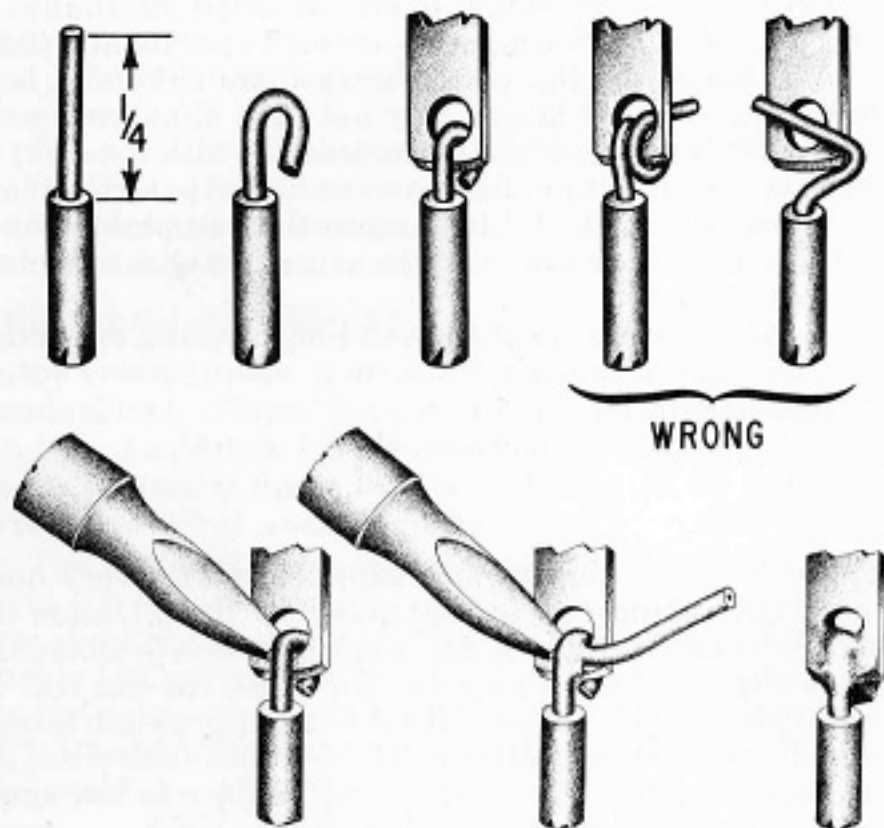

## WIRING THE KIT

The position of all wire leads should follow the diagram closely, bearing in mind that the pictorial diagram has necessarily been distorted somewhat to show all connections clearly. See that uninsulated wires do not touch each other unless, of course, they are connected to the same point. It is especially important that uninsulated wires or component leads or terminals do not touch the chassis accidentally.

Whenever one wire is to be soldered to a connection, such as a lug terminal or circuit board hole, the instructions will indicate this by the symbol (S). If more than one wire is to be soldered to the same point, the instructions will cite the number of wires that should be connected to that point when it is to be soldered. If no soldering instruction is specifically given, do not solder; other connections will be made to that point before soldering is called for.

Check your work after each step, and make sure the entire step has been completed. When you are satisfied that it has been correctly done, check the space provided and go on to the next step. Be sure you read carefully the explanatory paragraphs in the assembly instructions.

The four etched circuit boards, which include most of the electronic components for the Stereo 416, have each been in-circuit tested before being packed into the kit. These tests include every significant performance criterion—gain, power, distortion, frequency response, functioning of protective circuitry—as well as provide precise adjustment of necessary circuit parameters to assure that your amplifier will meet or exceed the specifications when these instructions are adhered to, and all connections have been properly completed.

Where stranded wire is used, as on the transformer leads, be very careful not to cut through the strands when stripping the end. Where stranded wire is supplied for hookup wire in the kit, the strands will be bonded together to minimize this likelihood and make handling easier.

All mounting screws are installed from the *outside* of the chassis, and a nut with lockwasher attached, called a KEP nut, is used except when otherwise specified.

This kit uses many varieties of hardware. Before starting assembly, separate all the hardware by using an egg carton, muffin pan, or small cups. #4 (smallest), #6, #8, #10 and  $\frac{1}{4}$ " (largest) machine screws are used in various lengths. The quantity supplied—from the parts list on page 40—will help to distinguish unfamiliar types. When the instructions call for #6 *long* screws, use the  $\frac{1}{2}$ " length. The *short* #6 screws are  $\frac{5}{16}$ " in length. There are also short #6 screws with lockwashers attached, called SEMS screws. Separate these now to avoid confusion. Sheet metal screws have a much more coarse (widely spaced) thread.

The connecting lugs on some components may not contain holes for easy mechanical connection, and the center "C" (collector) lugs of the sockets for the output transistors have a notch rather than a hole. Crimp the wire in a tight "U" around the lug or in the notch to hold it securely for soldering. In such cases, it may be helpful to strip *slightly* more than the usual  $\frac{1}{4}$ " of insulation from the wire. Note that mechanical crimping of the wire serves only to hold the wire stationary until soldering is called for. The integrity of every solder connection is essential.



The pictorial diagram serves to clearly trace all connecting wires for verification of proper construction. It cannot at the same time show all wires in their exact location on the chassis. While placement of wiring is not critical in the Stereo 416, you should follow the written instructions and the photos on back of the pictorial diagram for wire placement, rather than the diagram. Some wires may seem unduly long for final assembly, but this extra length provides for future service accessibility.

Transistor equipment will not tolerate wiring errors, sloppy or incomplete soldering. TAKE THE TIME TO BE NEAT AND ACCURATE, and your amplifier will operate properly at first, and for many years.

### MECHANICAL ASSEMBLY

Place the large black heat sink assembly before you, turned upside down so that the four terminal strips are visible. The back of the heat sink has six large holes punched in the vertical rib; the front rib has only three large holes. Below this, you will also see six small threaded holes in the front fin.

- 1( ) Select the 3 rubber grommets and insert them in the large holes in the front rib from the outside.
- 2( ) Select the dual input socket strip, the matching insulator strip, 2 small flat washers, and two sets of #6 long hardware ( $\frac{1}{2}$ " screws and KEP nuts). This input socket strip mounts *inside* the center of the back rib, with the sockets projecting into the holes. Insert the screws from the outside, install the insulator first, then a flat washer on each screw, followed by the socket strip and nuts. The  $\frac{1}{2}$ " screws will engage the nuts securely, but will not project through.
- 3( ) Select the 2 black binding posts (each is in two parts), and 2 chrome plated #10 nuts. Install the black binding posts from the *outside* of the back rib in the inner holes nearest the input socket strip. Note the molded shoulder on each section which centers the post in the hole. Loosely secure the post with the nut. Unscrew the cap, and observe the connecting hole through the post. Keep this hole vertical as you tighten the nut securely. The small Allen wrench dropped through the hole is a convenient alignment device.

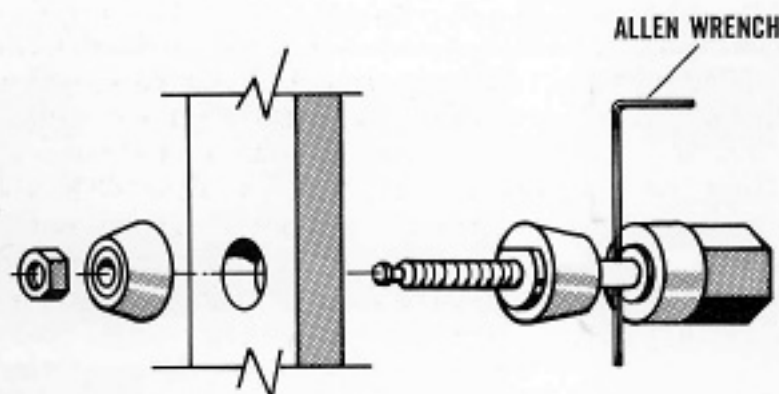

- 4( ) Select the 2 red binding posts and the 2 remaining chrome nuts. Install them adjacent to the black posts in the outer holes in like manner, being sure to keep the connecting hole vertical as before, and tighten the nuts securely.

Set the heat sink aside and select the inner front panel. The edges are bent toward the inside. The *large* rectangular hole (for LED circuitry) is at the top of the panel.

- 5( ) Select the square power switch, the cardboard insulator for the switch, and the large  $\frac{1}{2}$ " nut. Slip the cutout of the insulator on the switch bushing, and install the switch from the inside through the upper right panel hole PS. Note the key which engages the slot on the switch bushing. Rotate the insulator so the long end is positioned over the top edge of the panel. Secure the switch with the nut on the outside.
- 6( ) Select the 2 control potentiometers and two  $\frac{3}{8}$ " nuts. Install the controls in the left panel holes LV and RV so that the locating lugs engage the small holes in the panel.
- 7( ) Select the 12 lug rotary switch, #333025, and a  $\frac{3}{8}$ " nut. Do not confuse it with the other 12 lug rotary switch, #333020, which will be called for in the next step. Install the switch in hole DS so the locating lug engages the small hole in the panel. Secure it with the nut on the outside.
- 8( ) Select the 12 lug rotary switch, #333020, and a  $\frac{3}{8}$ " nut. Install the switch in hole LS, engage the locating lug in the small panel hole, and secure the nut on the outside.
- 9( ) Select the 2 lamp sockets and 2 sets of #6 short hardware. Insert the screws from the outside through holes DL and DR near the center, install the socket pointing downward, and secure each with a nut.
- 10( ) Select the two red neon indicator lamps. Trim the leads of each lamp to  $1\frac{1}{2}$ ", and prepare their ends by removing  $\frac{1}{4}$ " of insulation from each lead. Install the lamps from the *outside* of the panel in holes HL and PL so the metal ring of the lamp is against the panel on the outside. No hardware is necessary.
- 11( ) Select the longer 6-lug terminal strip (with the "O" or loop style lugs) and two sets of #6 short hardware. Install the strip so that it is centered between the two neon lamps.
- 12( ) Select the single button switch, 2 of the  $\frac{3}{4}$ " self tapping #4 screws with tapered ends, and 2 short tubular spacers. Insert the screws from the outside in position CS, slip the spacers over the screws on the inside, and carefully install the switch so the "O" style lugs point toward the left side of the panel. The screws cut their own threads; no nuts are necessary.

Be particularly careful in handling the circuit boards, as they represent a substantial portion of the cost of the Stereo 416. Because space is restricted, many of the components stand upright on the board, and careless handling can unduly flex and possibly break their leads. There are also a number of adjustable components on the circuit board whose values (positions) have been precisely set under operational test conditions for optimum performance. Be *very careful* that none of these is disturbed in handling the boards.

- 13( ) Select the PC-29 circuit board, 2 of the L-shaped metal mounting brackets and 4 sets of #4 hardware. Install the brackets on the *components side* of the board at the corners above and below the push button switches. The brackets point toward the components so that the mounting holes line up with the switches.

Insert the screws first through the board from the back (circuit) side of the board, then through the bracket, with each nut against the bracket. Do *not* tighten these nuts.

- 14( ) Select the 2 remaining  $\frac{3}{4}$ " self tapping #4 screws and the last 2 short tubular spacers. Insert the screws from the outside in the small holes at the left of the front panel (next to the pair of large holes), and slip the spacers over the screws on the inside. While supporting the switch assembly on the PC-29 board over the screws, carefully install the PC-29 assembly with the components toward the center of the panel. Be sure the screws do not damage components on the board.
- 15( ) Select 2 sets of #4 hardware and fasten the PC-29 L-brackets to the front panel. Tighten these screws *first* and then go back and tighten the 4 screws securing the brackets to the circuit board.

Set the front panel assembly aside and select the large Z-shaped line cord bracket.

- 16( ) Select the line cord and the molded plastic strain relief. Mark the line cord 17" from the stripped wire ends. Bend the cord sharply back on itself at the marking so that a "V" is formed. Install the strain relief at the V as shown with the small end of the strain relief nearest the bared wire end. Insert the line cord through the hole in the end of the Z-bracket from the outside. With heavy pliers, crimp the two halves of the strain relief together around the wire to partially form the wire before insertion. Now grasp only the larger diameter portion of the strain relief with the tips of the pliers, squeeze it fully closed, and insert the combination into the hole. The strain relief will snap into its locked position when fully inserted.

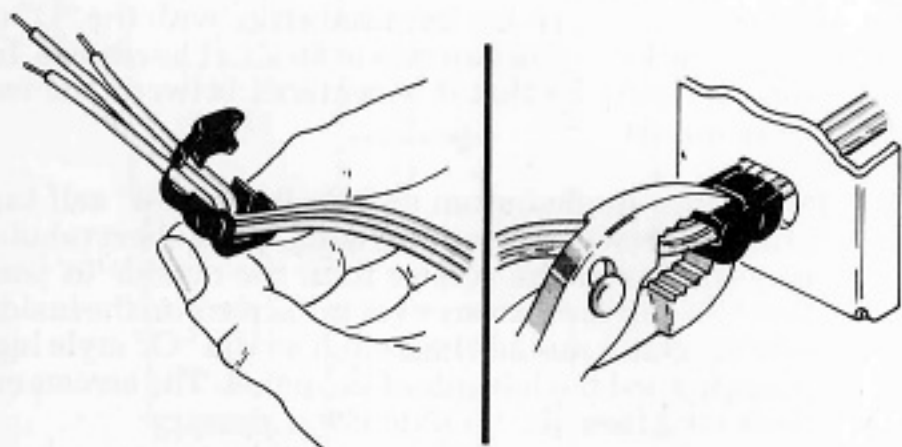

- 17( ) Select the rectangular 15 amp circuit breaker with the red button. (Units supplied for 220 volt AC operation will use a 7 amp breaker.) Remove the outer knurled nut and leave the hex nut snugly in place. Select the  $\frac{3}{8}$ " lockwasher and install it on the breaker. Mount the breaker from the inside of the Z-bracket above the line cord, with the side lug positioned *away* from the threaded mounting stud in the bracket. Secure it with the round knurled nut tightened with pliers.
- 18( ) Select the round black plastic access plug and snap it through the hole in the Z-bracket from the outside (red button side). Do *not* push your finger through it! Its removal from your finger necessitates its destruction, and playing with it can be painful.

Set the bracket assembly aside, and select the flat metal relay mounting plate. Hold it horizontally. When you are looking at the top surface, the upper left corner is notched out.

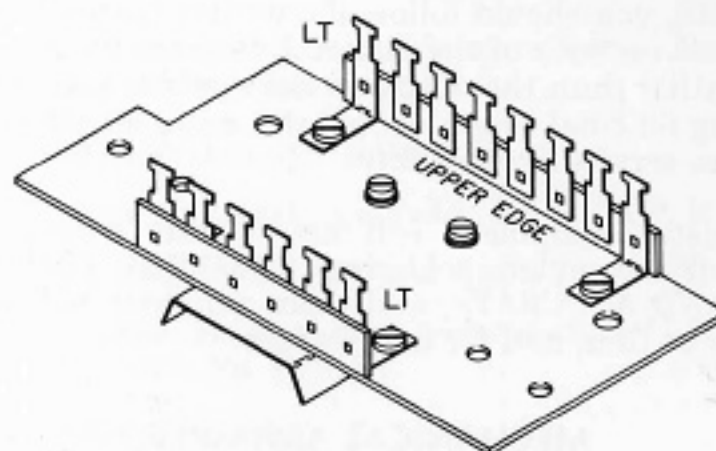

- 19( ) Select the 8-lug terminal strip and 2 sets of #6 short hardware. Install the terminal strip along the top surface *upper edge* of the relay mounting plate.
- 20( ) Select the remaining 6-lug terminal strip and 2 sets of #6 short hardware. Install the strip along the top surface *lower edge* of the mounting plate.
- 21( ) Select the 2 dual clip fuse blocks and 4 sets of #6 long hardware. Fasten the fuse blocks on top of the plate in each lower corner. The nuts go underneath the plate.
- 22( ) Select the relay and two #6 SEMS screws (lockwashers are attached). Mount the relay underneath the plate via its two threaded holes, so that the insulating piece projects slightly beyond the lower edge of the plate. Note the relay terminals are shown in the pictorial diagram outside the relay mounting plate.

Set the relay assembly aside and select the main chassis. The single large hole in the side is nearest the front edge. You are looking at the inside when the sides are upturned. All hardware should be installed with the screw heads on the *outside* of the chassis.

- 23( ) Select the 4 large rubber feet and the four  $\frac{1}{4}$ " diameter bolts. Push the bolts through the feet until the heads are fully recessed and then mount the feet at the four corners of the chassis on the *outside*.

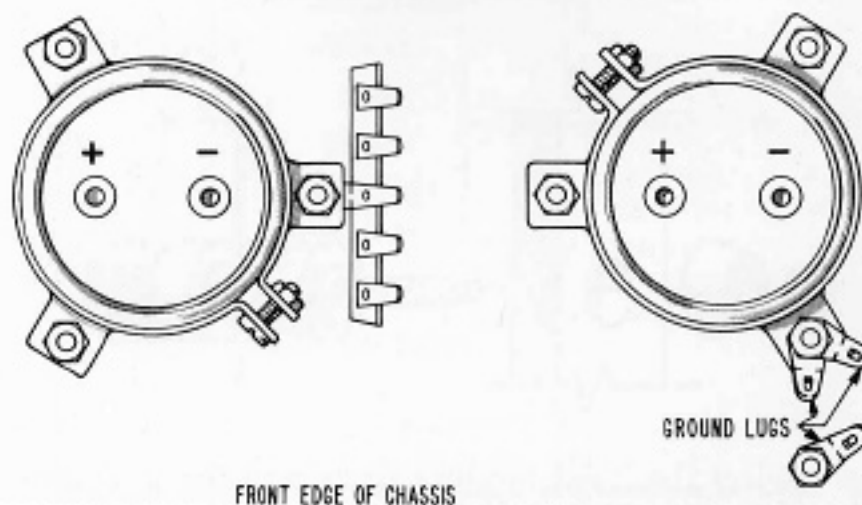

- 24( ) Select one of the large 10,000 mfd capacitors, one of the large circular capacitor mounting brackets, the 5-lug terminal strip, and 4 sets of #6 hardware (with one long and three short screws). Do *not* remove the plastic outer insulation from either of these capacitors. This bracket will be installed near the left front corner of the chassis. Note in the sketch above the

correct orientation of the clamp, and also the direction of inserting the clamping screw. One set of #6 long hardware is first to be installed in the clamp before mounting. Insert the capacitor in the clamp and temporarily tighten the clamp. Insert a screw in the *right* hole, slip the terminal strip over the screw on the inside, install the bracketed capacitor over the terminal strip, followed by a nut. Install the other two sets of hardware. Orient the terminal strip as shown in the sketch, and tighten the hardware.

- 25( ) Select the remaining large capacitor and its bracket, 2 of the ground lugs, 1 long and 2 short #6 screws, one #6 SEMS screw, and 4 nuts. Slide the capacitor into the bracket as before with the long clamping screw oriented as in the diagram. Insert the SEMS screw in the *front* hole, slip the 2 ground lugs over the screw on the inside, install the bracketed capacitor over the ground lugs, followed by a nut. Install the other two sets of hardware. The ground lugs should be separated by about  $\frac{3}{8}$ " to make connection of wires easier. They should be bent up to a vertical position. Make *certain* that this connection is *mechanically tight* because this is the main ground connection for the amplifier. Loosen the clamping screws and orient both capacitors so that the terminals are in line across the chassis, identified left to right in this order: (+), (-), (+), (-). The negative terminals may not carry a specific marking. Now securely tighten the clamping screws on both capacitor brackets.
- 26( ) Select a ground lug, a #6 SEMS screw, and a nut. Install the lug in line with the other two ground lugs toward the front edge of the chassis. As before, be certain this lug is very tight.
- 27( ) Select the 4-pin heavy duty socket, four  $\frac{3}{4}$ " #6 screws, and 4 nuts. Install the socket from the inside over the single large hole in the right upturned side of the chassis. Note that the socket has a cutout or keyway in its inside circular opening. Orient the keyway toward the front, upper corner. Make certain the 4 solder posts point toward the diode block. Securely fasten the hardware with the nuts on the inside.

The next several steps describe the application of silicon thermal compound. A thin uniform film of thermal compound is needed to provide maximum heat transfer from the diode block to the chassis, and from an output transistor to the heat sink. Excess compound will be messy, and is a disadvantage, since the compound is intended only to fill minute voids between flat surfaces. This thermal compound can be most annoying if carelessly handled. Clean up any excess with paper tissues as you go along. It is difficult to remove from clothing, and the best removal agent, if needed, is Freon—a degreasing agent available in a pressure spray can at electronic supply houses.

One of the easiest ways to handle this compound is to apply it with the blade of a screwdriver or a toothpick. However, the screwdriver used should be other than the one employed to install the hardware.

- 28( ) Select the one inch square diode block, the remaining small flat washer, the last  $\frac{3}{4}$ " #6 screw, and a nut. Note that the terminals of the block are identified "+", "-", and (two) "AC". The block will be mounted next to the right front foot with the "+" terminal

(which may be identified by a red dot or a very small locating lug on the flat surface) over a tiny hole in the chassis. *Make certain this diode block is correctly oriented.* Apply a thin film of thermal compound to the bottom (flat surface) of the block and install it over the screw through the chassis. Secure it with the flat washer and then the nut. Recheck the location of the "+" terminal and tighten the hardware securely. Wipe off any thermal compound which may have contacted the lug terminals on the block.

Set the chassis aside and return now to the large heat sink assembly. The sixteen output transistors plug into sockets on the heat sink ribs. Note that the holes for the transistor pins in the sockets are off-center. The longer end is identified with an "E" stamped in the fiber adjacent to a lug, and the shorter end is stamped with a "B" also adjacent to a lug. The center "C" lug is unmarked.

The metal insulators (shaped like the transistors) are hard-anodized for excellent thermal conductivity with electrical isolation. Do not scratch them. Apply the thermal compound in a *very thin film* to both surfaces while holding it by the tab at the "B" end. Position the insulator correctly, and install it on the transistor. Then the combination is installed on the outside of the heat sink rib and plugged into a socket on the inside.

The simplest procedure seems to be the following: after placing the compound coated insulator on the transistor, wipe each transistor pin clean of all compound. Then position the combination to properly match the mounting holes, and press it against the heat fin on the outside with a *slight* twisting motion to assure uniform contact. While holding it in place, snap the socket over the pins from the inside. When firmly engaged, this will hold each assembly temporarily so that the screws can be installed from the outside in one final operation to minimize smearing.

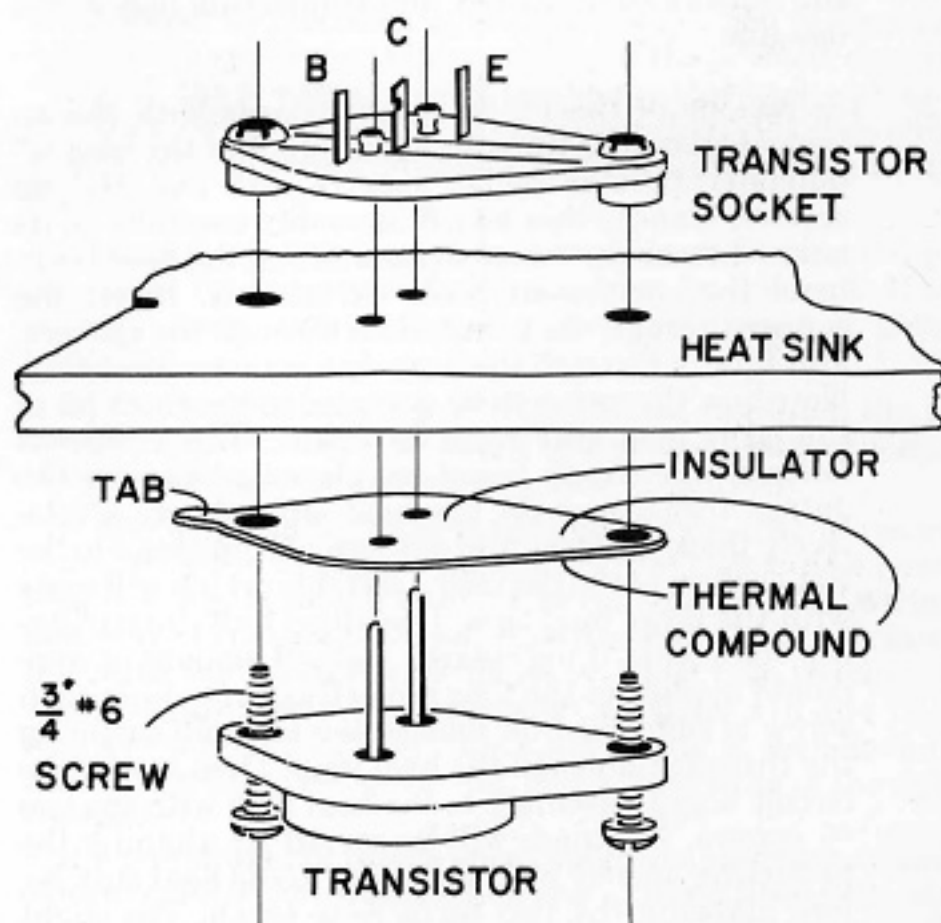

- 29( ) Select the 8 transistors, Part #561356 (2N6029 or 2N6030), 8 metal insulating wafers, 8 transistor sockets, the thermal compound, and 16 of the  $\frac{3}{4}$ " #6 sheet metal screws (coarse threads with slightly tapered ends). Do not confuse these transistors with the eight 571104 transistors, which look the same, but will be mounted in the next step. First check to see that the transistor pins are straight. These 8 transistors will be mounted on the *outside* of the back heat sink rib (the one with the red and black binding posts). The longer "E" end of each socket is positioned to the LEFT, as viewed in the pictorial diagram. Apply a *thin* film of compound to both sides of the insulator, orient it correctly, and install it over the transistor pins. *Wipe the pins clean*, and plug each assembly through the heat sink rib into the transistor socket. Secure each with 2 sheet metal screws.
- 30( ) Select the 8 transistors, Part #571104 (2N5629 or 2N5630), the 8 remaining insulating wafers, the 8 remaining transistor sockets, and 12 of the  $\frac{3}{4}$ " sheet metal screws. Check for straight transistor pins. Apply thermal compound to the insulating wafers as before, wipe the pins clean, and install them on the *outside* of the front heat sink rib. The longer "E" socket end is positioned to the RIGHT. The 12 sheet metal screws are installed only in the three outside transistors (Q2, Q3, Q4) until the next step.
- 31( ) Select the two  $\frac{1}{2}$ " diameter thermal sensors, the two spring metal clips shaped somewhat like the power transistors, and the 4 remaining  $\frac{3}{4}$ " sheet metal screws. Apply a *thick* film of thermal compound to the central portion of the round case section of the two inside (Q1) transistors on the front rib (those which have not yet been attached with screws). Slide the spring metal brackets over the lugs of the sensors so that the mounting flange projects in front of the flat surface of the sensor and fasten one assembly on top of each of the inner transistors with the sheet metal screws. Rotate the sensors slightly before the screws are tightened to get a good contact, and align the sensors so that their four connecting lugs are in one line.
- 32( ) Select one of the PC-28 circuit boards with the attached heat sink transfer assembly, 2 of the long  $\frac{1}{4}$ " diameter tubular metal spacers and two  $1\frac{1}{2}$ " #6 screws. Handle this board assembly carefully so as not to disturb the variable resistors on the board or to bend the component leads excessively. Insert the screws through the board, then through the spacers, and finally through the heat sink transfer assembly. Note how the unit will be mounted to the front fin of the large heat sink near the center. The *numbered holes* on the circuit board are placed *adjacent to the output transistors* on the heat sink. Apply a relatively thick uniform film of thermal compound to the flat surface of the transfer assembly which will mate with the large heat sink. Use about half the remaining compound if necessary. A small amount of compound applied to the four projecting threads on each screw is suggested for lubrication to avoid stripping the threaded holes in the heat sink. Then mount the circuit board assembly to the heat sink with the two #6 screws. Neatness will be served by aligning the projecting screws with the holes in the heat sink before allowing the two surfaces to touch. The slight twisting motion is not needed here.
- 33( ) Select the other PC-28 circuit board assembly, the remaining 2 long metal spacers, and the last two  $1\frac{1}{2}$ " #6 screws. Assemble this unit as before, handling the board carefully, and applying the compound fairly liberally, especially near the bend in the transfer assembly. Lubricate the projecting screws threads, *make sure the circuit board holes are adjacent to the output transistors*, and install this assembly at the end of the heat sink.
- 34( ) With a piece of wire lubricate 7 holes in the large heat sink assembly with the thermal compound as follows: the two holes in the front fin adjacent to the circuit board; the blind hole at one end of each rib where it joins the fin assembly; the two holes between the power transistors adjacent to each red binding post; the single hole under grommet G2.
- This completes the need for the compound. It is advisable to wipe off all the excess, including the threads of the transistor mounting screws, to avoid needless smears as you complete construction.
- 35( ) Select the 2 hollow black plastic transistor covers, and the two  $\frac{3}{4}$ " plastic screws. Install them on the back rib of the heat sink. Avoid excessive force on the plastic.
- 36( ) Select the round thermostat with an attached screw. Install it in the front rib of the heat sink in the hole under G2.
- The next two steps describe the assembly of the fan. Temporarily set aside the heat sink assembly.
- 37( ) Select the fan, the protective finger guard, and 2 sets of #6 long hardware. Place the fan with the head of the arrow indicating air flow toward your work surface, and the mating connection for the fan cord toward you on the left. Place the finger guard on top of the fan so that only the 4 lugs of the guard touch the 4 corners of the fan (if the guard is turned over, the guard will interfere with the fan blades). Secure the 2 lugs of the guard furthest from you to the fan with the hardware. Do not tighten.
- 38( ) Select the flat odd-shaped fan bracket, and 2 more sets of #6 long hardware. Hold the bracket so that its long flat section is toward you, and the cutaway corner is on the right. Slip the bracket between the finger guard and the fan, and align the holes in the bracket furthest from you with the remaining 2 lugs of the guard and holes of the fan. Install the hardware, and tighten the hardware in all 4 corners.
- This completes the basic mechanical subassembly portions of this kit. Set aside the fan assembly and select the heat sink assembly.

### WIRING THE HEAT SINK

To simplify wiring, wherever possible these steps will first connect to the least accessible terminals or lugs, and connect to the easiest ones last. There are many components to be connected in this small space, and therefore NEAT WIRING IS IMPERATIVE. This area has been expanded considerably in the pictorial diagram for clarity. We suggest referring often to the photograph of the completely wired heat sink on the back of the pictorial diagram for exact location of the parts.

On each transistor socket, the "E" (emitter) lug is nearest the inside of the heat sink; the "B" (base) lug is nearest the edge of the heat sink; the "C" (collector) lug is in the center.

While transistors and diodes can be damaged by *excessive* heat, it is important that you solder each connection properly, apply enough heat to the junction so that when solder is applied it flows smoothly over the joint.

A good mechanical connection is important at each step. In a number of steps where final soldering of a terminal will not occur until several steps later, some builders may prefer to lightly "tack solder" each lead as they go along, but if you do this where the instructions do not call for soldering, be sure to leave open space on the terminal for future wiring.

Each lug of the terminal strips in this kit has two holes, the conventional one at the tip, and the other at the base through the insulating material. For ease of connection, the steps following will indicate soldering to the base or to the tip of a lug. The 2 holes will be independently soldered.

In the following 18 steps, 2 sets of brackets for checking off, one below the other, are indicated:

( )  
( )

This means that the same instruction is to be completed *twice*, first for the right *channel*, and second for the left *channel*, before continuing to the next step. The wire lengths, directions and identifying numbers are identical for both sides.

Note that right and left *channel* designations are reversed relative to the left and right *sides* of the pictorial diagram of the heat sink, because the heat sink is upside down. Note also that the transistor "Q" numbers increase clockwise on the right channel, and counterclockwise on the left channel, beginning in the center of the front heat sink rib.

- 1( ) Prepare a 1½" red wire. Connect one end to T1 lug #1 ( ) at the base. Connect the other end to Q6E (S).
- 2( ) Prepare a 2¾" green wire. Connect one end to T1 lug ( ) #2 at the base. Connect the other end to Q5E (S).
- 3( ) Select a .18 ohm, 10 watt resistor. Do not confuse it ( ) with the 10, 600, 850 and 1k ohm resistors, which look the same. Trim each lead to 1". Connect one lead to T1 lug #1 at the base (S-2). Connect the other lead to T2 lug #3 at the base.
- 4( ) Select another .18 ohm, 10 watt resistor. Trim each ( ) lead to 1". Connect one lead to T1 lug #2 at the base (S-2). Connect the other lead to T2 lug #3 at the base (S-2).
- 5( ) Select another .18 ohm, 10 watt resistor. Trim each ( ) lead to 1". Connect one lead to T1 lug #3 at the base. Connect the other lead to T2 lug #4 at the base.
- 6( ) Select the last .18 ohm, 10 watt resistors. Trim each ( ) lead to 1". Connect one lead to T1 lug #4 at the base. Connect the other lead to T2 lug #4 at the base (S-2).
- 7( ) Prepare a 2½" green wire. Connect one end to T1 lug ( ) #3 at the base (S-2). Connect the other end to Q1E (S).
- 8( ) Prepare a 1½" red wire. Connect one end to T1 lug ( ) #4 at the base (S-2). Connect the other end to Q2E (S).

See that all resistors are flat against the bottom of the heat sink.

- 9( ) Prepare six 1½" black wires, and connect them as ( ) follows:
  - a( ) One end of the 1st wire to Q5C, and the other ( ) end to Q6C;
  - b( ) One end of the 2nd wire to Q6C (S-2), and the ( ) other end to Q7E;
  - c( ) One end of the 3rd wire to Q7E (S-2), and the ( ) other end to Q8E (S);
  - d( ) One end of the 4th wire to Q4E, and the other ( ) end to Q3E;
  - e( ) One end of the 5th wire to Q3E (S-2), and the ( ) other end to Q2C;
  - f( ) One end of the 6th wire to Q2C (S-2), and the ( ) other end to Q1C (S).
- 10( ) Prepare four 1½" green wires, and connect them as ( ) follows:
  - a( ) One end of the 1st wire to Q5B (S), and the ( ) other end to Q6B;
  - b( ) One end of the 2nd wire to Q7C (S), and the ( ) other end to Q8C;
  - c( ) One end of the 3rd wire to Q4C (S), and the ( ) other end to Q3C;
  - d( ) One end of the 4th wire to Q2B (S), and the ( ) other end to Q1B.
- 11( ) Prepare a 2¾" green wire. Connect one end to T2 lug ( ) #2 at the base (S). Connect the other end to Q8C (S-2).
- 12( ) Prepare a 4¾" green wire. Connect one end to T2 lug ( ) #5 at the base (S). Connect the other end to Q3C (S-2).
- 13( ) Remove 2½" of insulation from the roll of yellow wire, ( ) and cut the insulation in 2 equal pieces.
- 14( ) Select a 10 ohm, 2 watt resistor (brown-black-black), ( ) but do not cut its leads. Slip a piece of yellow insulation on each lead, and connect one lead to T2 lug #1 at the tip. Connect the other lead to Q7B (S).
- 15( ) Select another 10 ohm, 2 watt resistor (brown-black- ( ) black). Cut one lead to 1", and the other lead to ¾". Connect the shorter cut lead to T2 lug #1 at the tip. Connect the other lead to Q8B (S).
- 16( ) Remove 2" of insulation from the roll of yellow wire, ( ) and cut the insulation in a 1¼" and a ¾" piece.
- 17( ) Select a 10 ohm, 2 watt resistor (brown-black-black). ( ) Cut one lead to 1", but do not cut the other. Slip the longer insulation piece on the uncut lead, and the shorter piece on the other lead. Connect the uncut lead to T1 lug #5 at the tip. Connect the other lead to Q4B (S).
- 18( ) Select the last 10 ohm, 2 watt resistors (brown-black- ( ) black). Cut one lead to 1", and the other lead to ½". Connect the shorter cut lead to T1 lug #5 at the tip. Connect the other lead to Q3B (S).

In succeeding steps connections will be made to plated-through holes on the circuit boards. A good connection is more certain if the tip of the wire is first "tinned" by heating it and applying a *very small amount* of solder before it is connected to the hole. Insert the wire in the hole so that bare wire is visible on *both* sides of the board. Let the soldering iron contact the junction of wire and board circuitry as you feed solder to the junction. Solder should flow smoothly from the circuitry, *around the hole* to completely surround the wire. Keep the wire steady while the connection cools, and then wiggle it to make sure the connection is secure. If in doubt, reheat the connection and add more solder.

Do *not* add solder to the holes before a wire is inserted. If you do, it will be difficult to find the hole to clear it. However, should you solder a wire in error to a wrong hole, first remove the wire by using the iron, and while the solder is still hot, push a toothpick through the hole to clear it.

The following steps refer to connections for the *right channel*, and to the *right channel* PC-28, which is mounted in the *center* of the heat sink. Connections are made to the *foil side* (not the components side) of the board.

- 19( ) Prepare a 9" red wire. Pass one end through grommet G1 and connect it to Q5C (S-2). Connect the other end to PC-28 hole #9 (S).
- 20( ) Prepare an 8¾" black wire. Pass one end through G1 and connect it to Q6B (S-2). Connect the other end to hole #8 (S).
- 21( ) Prepare an 8" black wire. Pass one end through G1 and connect it to Q4E (S-2). Connect the other end to hole #11 (S).
- 22( ) Prepare a 7½" green wire. Pass one end through G1 and connect it to Q1B (S-2). Connect the other end to hole #10 (S).
- 23( ) Prepare a 6" green wire. Pass one end through G1 and connect it to T1 lug #5 at the tip (S-3). Connect the other end to hole #14 (S).
- 24( ) Prepare a 6¾" red wire. Pass one end through G1 and connect it to T1 lug #3 at the tip (S). Connect the other end to hole #13 (S).
- 25( ) Prepare a 7" green wire. Pass one end through G1 and connect it to T1 lug #1 at the tip (S). Connect the other end to hole #12 (S).
- 26( ) Select a 1 K (1000) ohm, 10 watt resistor, but do not cut its leads. Do not confuse it with the other 10 watt resistors. Connect one lead to the right channel *black* binding post. Pass the other lead through T2 lug #3 at the tip, bend the lead end in a tight "U", and connect it to T2 lug #4 at the tip. Trim off any excess wire at T2 lug #4.

All diodes supplied have their cathode end marked with a stripe, an arrow head, or a colored tip. It is this *marked* cathode end that will be referred to in several subsequent steps. The accompanying sketch shows the diodes more than double size.

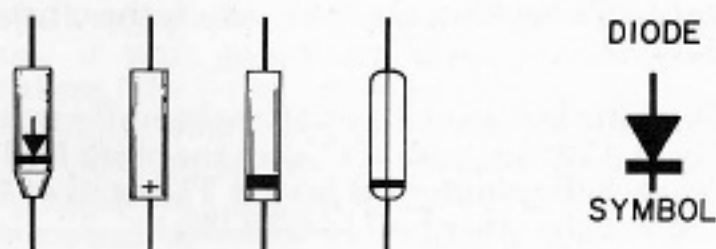

- 27( ) Select one of the 4 diodes, part #544012 (or 1N4003). Trim each lead to ½", and bend the leads more than 90° to its body. Connect the lead on the *marked* end to T2 lug #5 at the tip. Connect the other lead to T2 lug #4 at the tip.
- 28( ) Prepare a 10¾" red wire. Pass one end through G1 and connect it to T2 lug #4 at the tip (S-3). Connect the other end to hole #7 (S).
- 29( ) Prepare an 8" red wire. Pass one end through G1 and connect it to T2 lug #5 at the tip. Connect the other end to hole #15 (S).
- 30( ) Prepare a 15" white wire. Pass one end through the center grommet G2 and connect it to T2 lug #5 at the tip (S-3). The other end remains unconnected until later.
- 31( ) Select a diode, part #544012 (or 1N4003). Trim each lead to ½", and bend the leads more than 90° to its body. Connect the lead on the *marked* end to T2 lug #3 at the tip. Connect the other end to T2 lug #2 at the tip.
- 32( ) Prepare a 22" yellow wire. Pass one end through G2 and connect it to T2 lug #3 at the tip (S-3). The other end remains unconnected.
- 33( ) Prepare 11½" black wire. Pass one end through G1 and connect it to T2 lug #2 at the tip. Connect the other end to hole #4 (S).
- 34( ) Prepare a 16" blue wire. Pass one end through G2 and connect it to T2 lug #2 at the tip (S-3). The other end remains unconnected.
- 35( ) Prepare an 11¼" green wire. Pass one end through G1 and connect it to T2 lug #1 at the tip (S-3). Connect the other end to hole #5 (S).
- 36( ) Prepare a 19" blue wire, but remove ½" of insulation from one end. Pass the shorter bared end through G1 and connect it to the right black binding post (S-2). A considerable amount of heat is required to solder these posts. The other end remains unconnected.
- 37( ) Prepare a 16" yellow wire. Pass one end through G1 and connect it to the right red binding post (S). The other end remains unconnected.

The following steps refer to connections for the *left channel*, and to the *left channel* PC-28, which is mounted on the *right* of the heat sink. Connect to the foil side of the board.

- 38( ) Prepare a 7" red wire. Pass one end through grommet G3 and connect it to Q5C (S-2). Connect the other end to PC-28 hole #9 (S).
- 39( ) Prepare a 6½" black wire. Pass one end through G3 and connect it to Q6B (S-2). Connect the other end to hole #8 (S).
- 40( ) Prepare a 6" black wire. Pass one end through G3 and connect it to Q4E (S-2). Connect the other end to hole #11 (S).
- 41( ) Prepare a 5¼" green wire. Pass one end through G3 and connect it to Q1B (S-2). Connect the other end to hole #10 (S).

- 42( ) Prepare a 5" green wire. Pass one end through G3 and connect it to T1 lug #5 at the tip (S-3). Connect the other end to hole #14 (S).
- 43( ) Prepare a 5¼" red wire. Pass one end through G3 and connect it to T1 lug #3 at the tip (S). Connect the other end to hole #13.
- 44( ) Prepare a 5½" green wire. Pass one end through G3 and connect it to T1 lug #1 at the tip (S). Connect the other end to hole #12 (S).
- 45( ) Select the remaining 1 K (1000) ohm, 10 watt resistor, but do not cut its leads. Connect one lead to the left channel *black* binding post. Pass the other lead through T2 lug #3 at the tip, bend the lead end in a tight "U", and connect it to T2 lug #4 at the tip. Trim off any excess wire at T2 lug #4.
- 46( ) Select a diode, part #544012 (or 1N4003). Trim each lead to ½", and bend the leads more than 90° to its body. Connect the lead on the marked end to T2 lug #5 at the tip. Connect the other lead to T2 lug #4 at the tip.
- 47( ) Prepare a 7½" red wire. Pass one end through G3 and connect it to T2 lug #4 at the tip (S-3). Connect the other end to hole #7 (S).
- 48( ) Prepare a 7¼" red wire. Pass one end through G3 and connect it to T2 lug #5 at the tip. Connect the other end to hole #15 (S).
- 49( ) Prepare a 15" blue wire. Pass one end through the center grommet G2 and connect it to T2 lug #5 at the tip (S-3). Starting at least 2 inches beyond the grommet, lightly twist together this blue wire with the white wire from G2 (about 3 or 4 complete twists). The other end remains unconnected.

This light twisting will only provide future identification. When twisting of the *heavy* (white, blue or yellow) wires is called for anywhere in this kit, it will be solely for purposes of identification or convenience, so only a few twists need be made.

- 50( ) Select the remaining diode, part #544012 (or 1N4003). Trim each lead to ½", and bend the leads more than 90° to its body. Connect the lead on the marked end to T2 lug #3 at the tip. Connect the other end to T2 lug #2 at the tip.
- 51( ) Prepare a 22" white wire. Pass one end through G2 and connect it to T2 lug #3 at the tip (S-3). The other end remains unconnected.
- 52( ) Prepare an 8½" black wire. Pass one end through G3 and connect it to T2 lug #2 at the tip. Connect the other end to hole #4 (S).
- 53( ) Prepare a 16" yellow wire. Pass one end through G2 and connect it to T2 lug #2 at the tip (S-3). Lightly twist together this wire with the single blue wire from G2. The other end remains unconnected.
- 54( ) Prepare an 8¼" green wire. Pass one end through G3 and connect it to T2 lug #1 at the tip (S-3). Connect the other end to hole #5 (S).
- 55( ) Prepare a 19" blue wire, but remove ½" of insulation from one end. Pass the shorter bared end through G3

and connect it to the left black binding post (S-2). Twist this wire together with the blue wire from G1, starting about 2 inches in front of the center grommet. The other end remains unconnected.

- 56( ) Prepare a 16" white wire. Pass one end through G3 and connect it to the left red binding post (S). Twist this wire together with the yellow wire from G1, starting 2 inches in front of the center grommet. The other end remains unconnected.
- 57( ) Prepare both a 20" red wire and 20" black wire. Pass one end of each of these wires through G2, so that the black wire projects 3" and the red wire 2½" through the grommet between the ribs of the heat sink. Twist them together two or three full turns, and connect the black wire to input socket lug #2. (S). Connect the red wire to input socket lug #1. (S). On the other side of the grommet twist these two wires together uniformly throughout their length so that there are about three full twists every 2 inches.
- 58( ) Prepare a 23" black wire and a 23" green wire. Pass these through G2, twist them as before and connect the black wire to input socket lug #3. (S). Make certain that this connection is kept separate from that of the black wire connected to input socket lug #2. Connect the green wire to input socket lug #4. (S). Twist the wires on the other side of the grommet throughout their length as before.
- 59( ) Select the 5 "U" shape brackets for the heat sink and 10 sets of #6 long hardware. The brackets are to be installed between the ribs of the heat sink with the long flat side out, and nearly flush with the edge of the rib. Four of the brackets are to be mounted adjacent to the Q1-Q8 and the Q4-Q5 transistors for the left and right channels. The last is facing out at the left channel end of the heat sink. Install the screws from the outside of each rib.
- 60( ) Prepare a 14½" red wire and a 14½" black wire. Twist these together uniformly throughout their length and connect one end of the black wire to *right* PC-28 hole #2. (S). Make this connection from the *front* (components side) of the circuit board. Connect the corresponding end of the red wire to hole #1 on the *front* side of the same board. (S).
- 61( ) Select a wire tie. Group together the twisted pair of wires from the previous step with the red-black and green-black twisted pairs from the input sockets. Tie these 6 wires together about 1" in front of hole #1 on *right* PC-28. The wire tie is simply looped around the bundle of wires, and the thin end pulled through the hole in the opposite end. Cut off the excess tie. Note that the wire ties called for in this kit are not shown on the pictorial diagram.
- 62( ) Prepare a 13½" green wire and a 13½" black wire. Twist these wires together throughout their length and connect one end of the black wire to the *front* of the *left* PC-28 hole #2. (S). Connect the corresponding end of the green wire to hole #1. (S).
- 63( ) Prepare a 13½" black wire. Connect one end to the *front* of the *right* PC-28 hole #3. (S). Note that hole #3 is very close to hole #2, and they represent a common circuit connection.

- 64( ) Prepare a 17½" black wire. Connect one end to the front of the left PC-28 hole #3. (S). Bring this wire across the PC-28 board in front of the row of holes and twist it lightly together with the single black wire from the right channel PC-28, so that the unconnected ends are even. These two wires will be connected to the same point in a later step.
- 65( ) Prepare a 14" red wire and a 12" red wire. Start with the two ends even, and twist them throughout their length to within ½" of the other end of the shorter wire. On the even end, connect one wire to the thermostat lug #1 (S). Connect the corresponding end of the other wire to thermostat lug #2 (S). The thermostat is located under grommet G2. Keep this pair away from the wires which have been bundled together with a tie.
- 66( ) Prepare a 4" white wire. Connect one end to thermal sensor lug #2 on the right channel Q1 (S). Connect the other end to thermal sensor lug #3 on the left channel Q1 (S).
- 67( ) Prepare a 20" white wire. Connect one end to thermal sensor lug #1 on the right Q1 (S).
- 68( ) Prepare another 20" white wire. Pass one end under the red-black and the green-black twisted pairs from G2 and connect that end to thermal sensor lug #4 on left Q1 (S). Twist this wire together with the white wire from the previous step throughout their length so that the unconnected ends are even.
- 69( ) Select a wire tie. Group together the 6 heavy wires from G2, the 2 each heavy wires from G1 and G3, the white pair from the thermal sensors, the red pair from the thermostat, and the black pair from hole #3 on each PC-28. Tie these 16 wires together just in front of hole #10 on right PC-28. Cut off the excess tie.

This completes the connection of wires to the heat sink. Before continuing, now is the time to check that there are no excessive solder blobs, and that no long ends project from a lug. See that no bare wires touch other than the intended lug. Shake out any loose wire clippings, and be certain that no bits of wire adhere to the thermal compound.

The heat sink should look like the photograph on the back of the pictorial diagram (the "U" shape brackets along the edge of the heat sink have been removed for clarity).

You are about half way to completion. Set the heat sink aside, and return to the main chassis with the capacitors near you.

### WIRING THE MAIN CHASSIS

- 1( ) Select the relay mounting plate and 2 of the ⅜" #10 SEMS screws with attached lockwashers. Install the plate on capacitor terminals C1 #2 (-) and C2 #3 (+), with the notched out corner of the plate adjacent to terminal #1.
- 2( ) Select the remaining two ⅜" #10 SEMS screws and the 2 remaining large ground lugs. Install the ground lugs facing to the front left on capacitor C1 lug #1, and to the front on C2 lug #4.

- 3( ) Prepare a 2¾" yellow wire but strip 1" of insulation from one end. Pass the longer bared end through fuse block lug #8 and connect it to fuse block #7. Solder only lug #8. Connect the other end to capacitor C2 lug #4 (S).
- 4( ) Prepare a 2¾" white wire, but strip 1" of insulation from one end. Pass the longer bared end through fuse block lug #3 and connect it to lug #4. Solder only lug #3. Connect the other end to capacitor C1 lug #1 (S).
- 5( ) Select the six .1 mfd disc capacitors. Do not confuse the single .01 mfd disc capacitor, which is used elsewhere. Trim the leads of all 6 capacitors to ¼" of bare wire.

These capacitors will be installed on the relay mounting plate terminal strips. For convenience, they will be connected to the small holes at the base of each lug terminal. When soldering is called for here, solder the leads to the lower portion of the terminal only. Future connections will be made to the larger portion of the terminal. Do not allow bare leads to touch the relay mounting plate.

- 6( ) Select one of the .1 mfd disc capacitors and connect one lead to fuse block lug #4 (S-2). Connect the other lead to LT lug #9. This capacitor and the one in the following step should point downward against the front edge of the relay plate.
- 7( ) Select another .1 mfd disc capacitor and connect one lead to fuse block lug #7 (S-2). Connect the other lead to LT lug #14.

The remaining 4 capacitors will be placed between the two terminal strips, and should lie flat against the relay plate. Note that the pictorial diagram has necessarily distorted the spacing of the components on the relay plate to clearly show wires which pass beneath it in the final assembly.

- 8( ) Select one of the .1 mfd disc capacitors and connect one lead to LT lug #9 (S-2). Connect the other lead to LT lug #10 (S).
- 9( ) Select another .1 mfd capacitor and connect one lead to LT lug #14 (S-2). Connect the other lead to LT lug #13 (S).
- 10( ) Select another .1 mfd capacitor and connect one lead to LT lug #3 (S). Connect the other lead to LT lug #4 (S).
- 11( ) Select the remaining .1 mfd capacitor and connect one lead to LT lug #5 (S). Connect the other lead to LT lug #6 (S).
- 12( ) Prepare a 3¾" black wire. Connect one end to relay lug #6 (S). This lug is located *under* the 6-lug terminal strip. The relay lugs are shown in front of and behind the relay mounting plate assembly in the pictorial diagram for ease in tracing wires. Connect the other end of this black wire to fuse block lug #5.

The connecting pins for the heavy duty socket CP have an open end rather than a hole. Simply insert the wire in the open end, and hold it in place as you solder.



- 13( ) Prepare two 7" black wires, but remove 1/2" from one end of each. Connect the shorter end of one wire to CP pin #3 (S). Connect the shorter end of the other wire to CP pin #4 (S). Lightly twist these wires together throughout their length, and connect the other ends of both wires to ground lug L1 (S-2). Because 5 wires will be connected to each ground lug L1 and L2, attach each wire by wrapping it around the lug, starting at the base of the lug with succeeding wires working upward. This is the main ground connection for the entire amplifier. Good solder connections here are essential. It is advisable to solder each wire in turn as you connect to these lugs.
- 14( ) Prepare a 16" white wire. Connect one end to CP pin #2 (S). Twist this wire once around the pair of black wires from the previous step, bend a small hook in the free end, and connect it to the bare wire between fuse block lugs #3 and #4 (S). Although another wire will connect to this bare wire, we suggest soldering the wire now.
- 15( ) Prepare a 12 1/2" yellow wire. Connect one end to CP pin #1 (S). Twist this wire once around the other wires to CP, bend a small hook in the end, and connect it to the bare wire between fuse block lugs #7 and 8 (S).

You will next install the few parts on circuit board PC-30. These items are to be installed on the side which does *not* contain foil pathways. Markings, lines and hole numbers indicate the placement of each part and where the parts or wires are inserted. Bend the leads at right angles to each component, and insert the leads so the part is flush against the board (except for the 2 large resistors). Turn the board over and solder each lead to the circuitry containing foil pathways. Then cut off the excess lead. Note that location R318 remains vacant, as it is not needed in the Stereo 416.

- 16( ) Select the PC-30 board and the 2 small diodes, part #540113 (or 1N4743). These are designated as D304 and D305. Each diode has the cathode end marked with a stripe, an arrow head, or a colored tip. Install each diode so that the arrow head on the board points toward the marked (cathode) end of the diode. Both diodes point in the same direction. Solder all 4 leads.
- 17( ) Select the two 500 mfd (or 470 mfd) capacitors. Before mounting these parts, notice that they are marked for polarity with a (+) sign, a (-) sign, or sometimes both symbols. Some capacitors have an arrow to further identify polarity. The board indicates a (+) symbol only for correct orientation. Install them in locations C302 and C303. These capacitors point in opposite directions. Solder all 4 leads.
- 18( ) Select the two 850 ohm, 10 watt resistors, and install them in locations R307 and R308. Do *not* place them against the board, but allow the leads to support each resistor 1/8" above the board. Solder all 4 leads. A good solder connection is essential.
- 19( ) Select 4 sets of #4 hardware and the 2 remaining L-shaped brackets. Install the brackets on the *components* side of PC-30, with the short leg of the bracket pointing away from the board, and adjacent to R308. Insert the screw through the board first, then through the bracket. Secure these loosely with a nut on each.

- 20( ) Select the vertical chassis brace and 2 sets of #4 hardware. Fasten the PC-30 brackets to the brace so the foil pathway side of the board is toward the shorter edge of the brace, and the components are adjacent to the bend. First tighten the brackets to the brace, and then tighten the brackets to the board.
- 21( ) Select two #6 SEMS screws (lockwashers attached). Install the brace on the chassis adjacent to capacitor C2. The front flange of the bracket will be flush with the front edge of the chassis.

A good connection to the plated-through holes on PC-30 is more certain if the wire is inserted in the hole so that bare wire is visible on both sides of the board. Solder should flow smoothly around the hole to completely surround the wire. Keep the wire steady as the connection cools, and then wiggle it to make sure the connection is secure. You may wish to apply solder to *both* sides of the board to be certain of a complete connection.

- 22( ) Prepare an 8" black wire, but remove 1/2" of insulation from one end. Connect the shorter bared end to the foil pathway (*front*) side of PC-30 hole #6 (S). Connect the other end to ground lug L1 (S).
- 23( ) Prepare a 13 1/2" white wire. Bend a small hook in one end and connect that end to the bare wire between fuse block lugs #3 and #4 (S). [There are now 2 wires connected to this bare wire.] Connect the other end to the *front* of PC-30 hole #1 (S).
- 24( ) Prepare a 9" yellow wire. Bend a hook in one end and connect it to the bare wire between fuse block lugs #7 and #8 (S). [Two wires are now connected here.] Connect the other end to the *front* of PC-30 hole #4 (S).

Terminal clips called for in future steps should be connected to the wire as follows: First "tin" that narrow portion of the clip shank which accepts the bared wire end. Then lay the wire in the clip so that the wider portion of the shank grasps the insulation. Solder the wire only in the narrow shank portion, and when it has cooled, squeeze the wider end around the insulation.

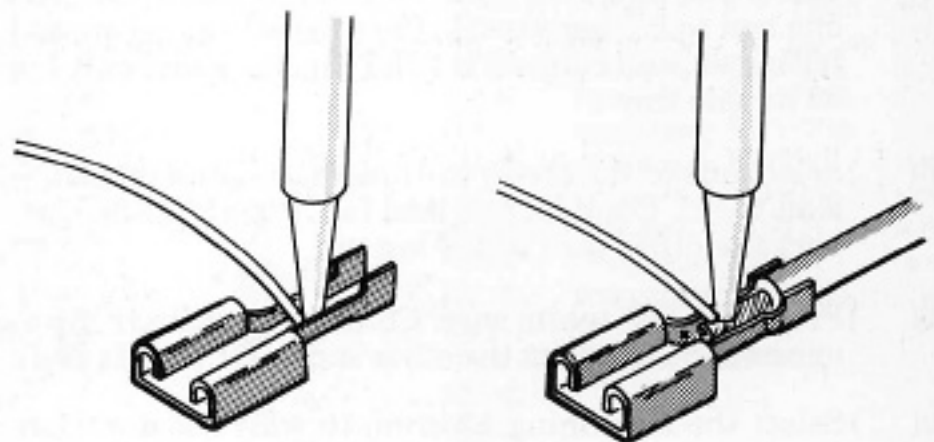

- 25( ) Prepare a 3" yellow wire. Install a terminal clip on one end (S). Connect the other end to the *front* of PC-30 hole #5 (S). Flow solder across the board to hole #4. Push the clip over the (-) terminal of the diode block, lug #1.
- 26( ) Prepare a 2 3/4" white wire. Install a terminal clip on one end (S). Connect the other end to the *front* of PC-30 hole #2 (S). Flow solder across the board to hole #1. Push the clip over the (+) terminal of the diode block, lug #3.

- 27( ) Prepare a 20" green wire. Connect one end to the front of PC-30 hole #3 (S).
- 28( ) Prepare a 21" red wire. Connect one end to the front of PC-30 hole #7 (S).
- 29( ) Prepare a 22½" black wire. Connect one end to the front of PC-30 hole #17 (S). Position this wire down past hole #3 and twist it lightly together with that green wire, and the red wire from hole #7. Place this group out of the way under the chassis.
- 30( ) Select the 600 ohm, 10 watt resistor. Trim each lead to ½", and bend the leads 90° to its body. Connect one lead to terminal strip FT lug #1 at the base. Connect the other lead to FT lug #5 at the base. Terminal strip FT is mounted on the chassis between the large capacitors. The diagram differs for clarity.
- 31( ) Prepare a 14" red wire. Connect one end to FT lug #5 at the base (S-2).
- NOTE: If this amplifier uses the international power transformer, part #464030, and is to be wired for either 200, 220 or 240 volts AC, instead select the 2,200 ohm, 10 watt resistor. Trim each lead to fit, and connect one lead to FT lug #5 at the base (S-2). Connect the other lead to FT lug #2 at the tip. Also prepare a 14½" red wire, and connect one end to FT lug #2 at the tip (S-2).*
- 32( ) Prepare a 14½" red wire. Connect one end to FT lug #1 at the base (S-2). Position this wire toward the front, and twist it lightly with the other red wire. Place this pair under the chassis.
- 33( ) Prepare a 2¾" red wire. Connect one end to relay lug #2 (S). Connect the other end to LT lug #4.
- 34( ) Prepare a 2½" green wire. Connect one end to relay lug #3 (S). Connect the other end to LT lug #5.
- 35( ) Prepare a 2½" black wire. Connect one end to relay lug #1 (S). Connect the other end to LT lug #3.
- 36( ) Prepare another 2½" black wire. Connect one end to relay lug #4 (S). Connect the other end to LT lug #6.
- 37( ) Select one of the 10 ohm, 10 watt resistors. Connect one end to LT lug #10 (S). Pass the other lead around LT lug #2, and connect it to LT lug #3. Solder only lug #2 at this time.
- 38( ) Select one of the choke coil assemblies and trim each lead to ½". Connect one lead to LT lug #3 (S-3). Connect the other lead to LT lug #11.
- 39( ) Prepare a 6½" white wire. Connect a terminal clip to one end (S). Connect the other end to LT lug #11 (S-2).
- 40( ) Select the remaining 10 ohm, 10 watt resistor. Connect one end to LT lug #13 (S). Pass the other lead around LT lug #7 and connect it to LT lug #6. Solder only lug #7 at this time.
- 41( ) Select the remaining choke assembly and trim its leads to ½". Connect one lead to LT lug #6 (S-3). Connect the other lead to LT lug #12. Now check to see that the choke coils do not touch each other, and that they are not able to touch the mounting plate.
- 42( ) Prepare an 8½" yellow wire. Install a terminal clip on one end (S). Connect the other end to LT lug #12 (S-2).
- 43( ) Prepare a 20" red wire and a 20" green wire. Lightly twist these two wires together throughout their length. Pass the pair under the relay between the two capacitors and connect the red wire to LT lug #4. Connect the green wire to LT lug #5. While later connections will be made to each of these terminals it is suggested that you solder the two wires on each terminal for security.
- 44( ) Prepare a 17" red wire and an 18" black wire. Starting with two even ends, lightly twist these wires together throughout their length except for 2" at the uneven end. At this uneven end connect the red wire to relay lug #5 (S). Connect the corresponding end of the black wire to LT lug #14. Place this pair of wires out of the way under the chassis.
- 45( ) Prepare a 6½" blue wire, but remove ½" of insulation from one end. Connect the longer bared end to ground lug L2 at the base of C2 (S). Connect the other end to LT lug #14 (S-2).
- 46( ) Select the Z-bracket and line cord assembly, and a terminal clip. The line cord has 3 conductors (wires). The center (green) conductor is the ground connection. Separate one of the outer conductors from the other two for a distance of 14". Cut off and discard 11" of this separate wire. Strip ¼" of insulation from the end, being careful not to cut through the strands of this wire. Twist the strands together tightly and tin them with solder. Install the terminal clip on this lead. (S). Push this terminal clip over the outer lug of the circuit breaker. This is *not* the lug marked with the red dot. You may separate the green ground lead from the remaining line cord lead for at least 8 inches.
- 47( ) Prepare a 13½" white wire. Connect a terminal clip to one end (S). Push this terminal clip over the circuit breaker lug marked in red. Set this assembly aside for the present.
- 48( ) Select the power transformer, the four ½" #10 screws, the 4 large flat washers, and the 4 #10 nuts. When installing the transformer, be careful of the components on the PC-30 board. Lift the 3 blue leads over the top of the board, and bring the 3 red leads out below the board before you attach the transformer to the chassis. Mount the transformer with the leads toward the front of the chassis, using a large flat washer on top of each foot before the nut is installed. Tighten these screws when the end of the transformer is against the vertical chassis brace.

The standard transformer for the Stereo 416, for use with 120 volts AC lines as in the United States and Canada, is part #464026. An alternative power transformer, part #464030, providing for other line voltage options, is available at extra cost. If there is *any possibility that you may require the optional transformer, do not install the standard version*, for it cannot be exchanged once it has been installed. Contact Dynaco about the cost differential and exchange provisions, and remember that the circuit breaker should be a 7 amp size for 200, 220, or 240 volt lines.

Instructions for connecting the primary windings of the international transformer for various line voltages will be found on page 35 of this manual. The following connections of the secondary windings are the same for both versions.

The transformer leads may be shortened for neatness, but if they are cut too short for re-use, and a defect should develop in the transformer, the guarantee on the transformer may be voided. Twist and tin the strands if you shorten a lead, and be sure all strands are soldered to each terminal.

Insofar as possible the transformer leads will conform to the colors indicated. If there is a variation, these leads will carry numbered tags which refer to the [number] following the color reference.

- 49( ) Connect the blue/yellow [7] lead to the back of PC-30 hole #16 (S).
- 50( ) Connect one of the 2 blue [6] leads to the back of PC-30 hole #14 (S). Connect the remaining blue [8] lead to the back of hole #19 (S).
- 51( ) Connect the red/yellow [4] lead to ground lug L1 at the base of C2 (S).
- 52( ) Connect the green [9] lead to ground lug L1 (S). There are now 5 wires soldered to lug L1.
- 53( ) Select 2 terminal clips. Install a clip on each of the 2 red [3] and [5] leads. Because each wire is quite heavy, you may wish to bend open the channel on the shank of the clip so that a good solder connection is assured. Twist these red wires lightly together and push one clip on diode block lug #2, and the other clip on lug #4.
- 54( ) Remove 1½" of insulation from the roll of black wire, and cut the insulation in 2 equal pieces. Select the .01 mfd (may be marked 103M) disc capacitor, and trim each lead to 1¼" (if required). Slip a length of insulation on each lead. One lead is to be connected to the terminal clip on each red transformer lead. Wrap the lead around the terminal shank, crimp it, and solder each. Standing the capacitor upright on these long leads makes it easier to disconnect these clips from the diode block if servicing should require it.
- 55( ) Select the Z-bracket line cord assembly, and two #6 SEMS screws. Thread the wires of this assembly from the back, under the outer edge of the transformer, and install the bracket at the right rear of the chassis. Install the bottom screw first, and then install only the center screw on the side.
- 56( ) Connect the green ground wire from the line cord to ground lug L3 (S). This is the only wire soldered to this lug.

This completes the second major portion of the amplifier wiring. Set this chassis assembly aside and select the front panel assembly.

### WIRING THE FRONT PANEL

There are 12 small ¼ watt resistors in this kit. 6 are to be mounted on the Dynaguard switch DS, and the other 6 on the LED range switch LS. All of these resistors will be mounted now. Trim each lead to no more than ½".

The DS switch lugs are numbered clockwise from the inside switch assembly bolt when looking at the back of the switch.

- 1( ) Select the two 220 ohm (red-red-brown) resistors. Connect a lead of one resistor to DS #10, and the other lead of that resistor to DS #11. Connect a lead of the second resistor to DS #4, and its other lead to DS #5.
- 2( ) Select the two 300 ohm (orange-black-brown) resistors. Connect a lead of one resistor to DS #11 (S-2), and the other lead to DS #12. Connect a lead of the second resistor to DS #5 (S-2), and its other lead to DS #6.
- 3( ) Select the two 82 ohm (grey-red-black) resistors. Connect a lead of one resistor to DS #10 (S-2), and the other lead to DS #9. Connect a lead of the second resistor to DS #4 (S-2), and its other lead to DS #3.

The LS switch lugs are also numbered clockwise from the left side assembly screw when looking at the back of the switch.

- 4( ) Select 2 of the 10,000 ohm (brown-black-orange) resistors. Connect one lead of one resistor to LS #9, and the other lead to LS #10. Connect a lead of the second resistor to LS #3, and its other lead to LS #4.
- 5( ) Select the remaining two 10,000 ohm (brown-black-orange) resistors. Connect a lead of one resistor to LS #10 (S-2), and the other lead to LS #11. Connect a lead of the second resistor to LS #4 (S-2), and its other lead to LS #5.
- 6( ) Select the two 18,000 ohm (brown-gray-orange) resistors. Connect a lead of one resistor to LS #9 (S-2), and the other lead to LS #8. Connect a lead of the second resistor to LS #3 (S-2), and its other lead to LS #2.
- 7( ) Prepare a 1½" black wire. Connect one end to LS #11 (S-2). Connect the other end to LS #5.
- 8( ) Prepare a 5" black wire, and a 5" red wire. Twist them lightly together and connect one end of the black wire to LS lug #5 (S-3). Connect the corresponding end of the red wire to DR lug #3. Position this pair over the top of the front panel.
- 9( ) Prepare a 15" black wire. Connect one end to LS #2 (S-2).
- 10( ) Prepare a 16" red wire. Connect one end to LS #8 (S-2). Position this wire across the switch and twist it lightly together with the black wire from LS #2. Position the pair around the left end of the smaller rectangular opening and over the bottom of the panel.
- 11( ) Prepare a 6" black wire, and a 6" green wire. Twist them lightly together, and connect one end of the black wire to LS #1 (S). Connect the corresponding end of the green wire to LS #7 (S). Position this pair over the top of the panel.

Before continuing, see that no wire end or resistor lead can touch other than the intended LS lug—that the wires do not interfere with the metal portions of DL and DR.

- 12( ) Prepare a 2" red wire. Connect one end to DL lug #1 (S). Connect the other end to DR lug #3.
- 13( ) Prepare a 22" green wire. Connect one end to switch DS #12 (S-2).

Now turn to page 24.

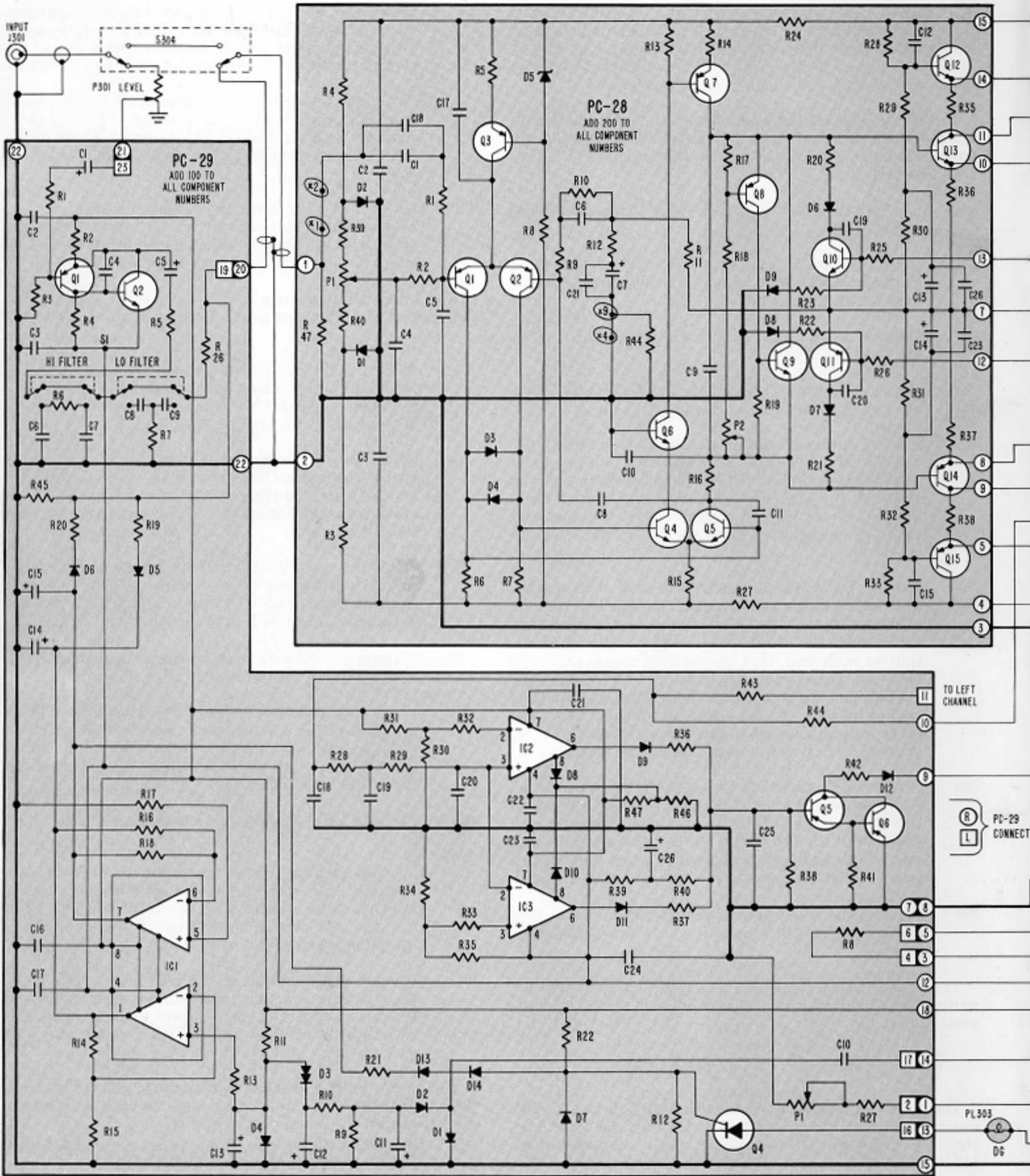

# SCHEMATIC DIAGRAM

©1977 DYNACO INC.

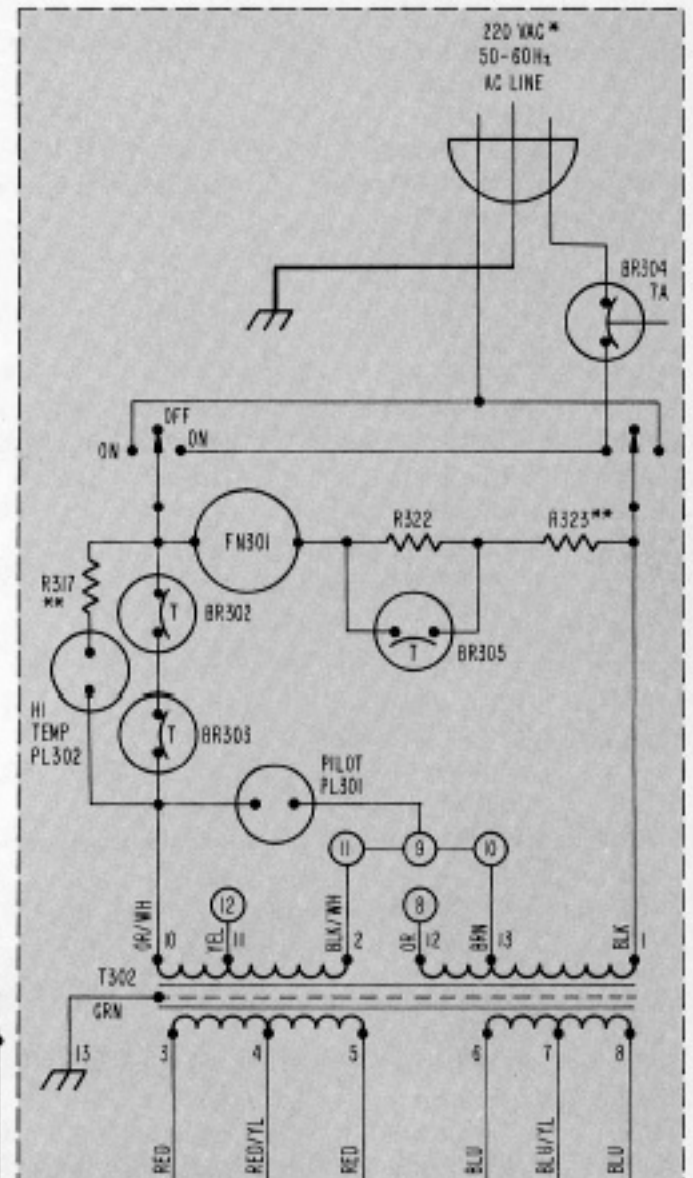
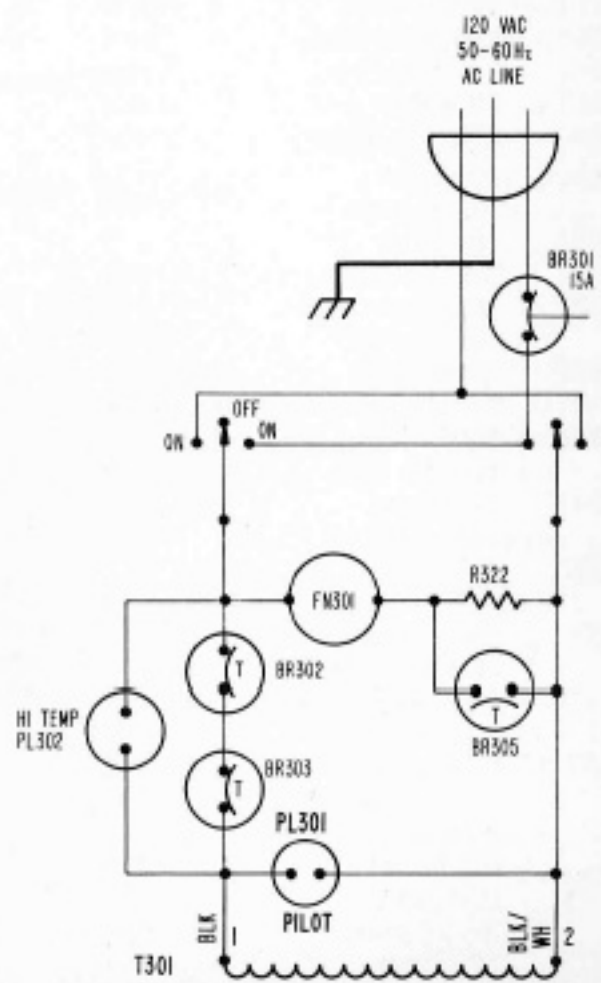
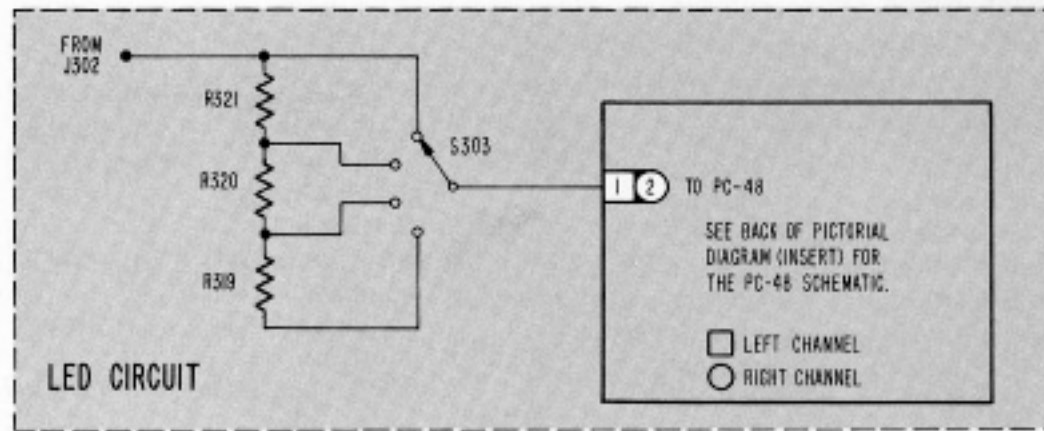
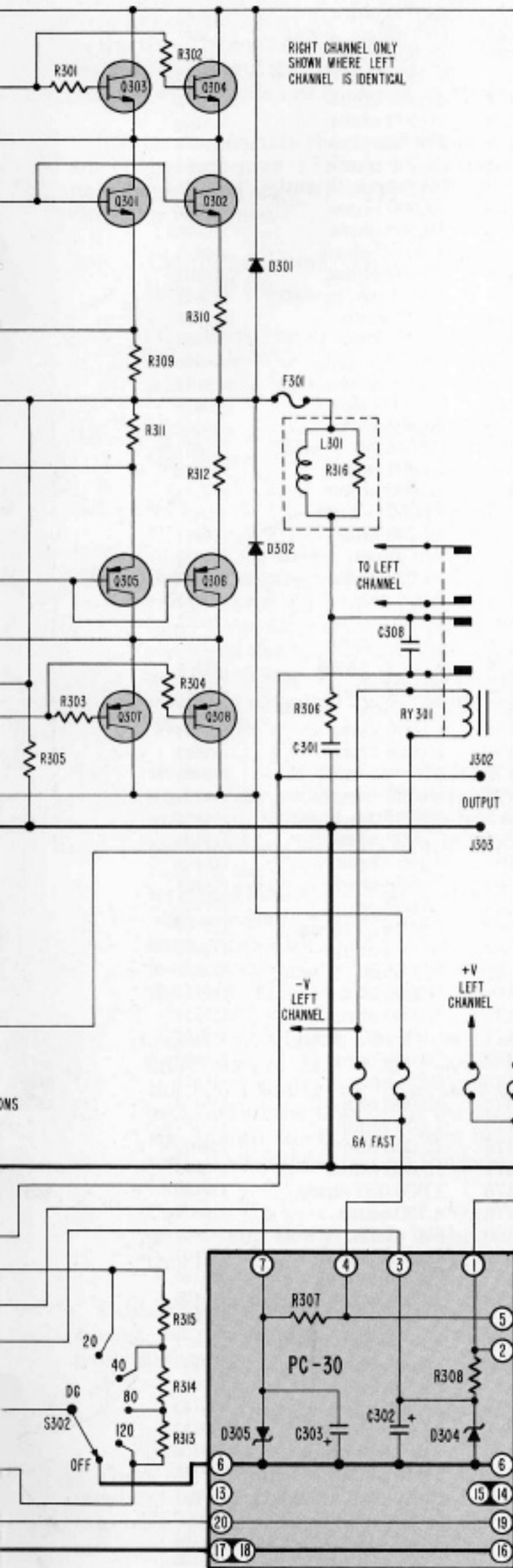

○ DENOTES PC-30 HOLES

## WIRING VARIATIONS, INTERNATIONAL TRANSFORMER (OPTION)

VOLTAGE	POWER SWITCH	BR 305	8	10	11	12
100 VAC	1,2	11,13	12	-	-	10
120 VAC	1,2	10,12	13	-	-	11
200 VAC	1	11	12	13	2	10
* 220 VAC	1	10	12	13	2	11
240 VAC	1	10	13	12	2	11

\* EXAMPLE  
\*\* R317 & R323 FOR 200, 220, 240 VAC ONLY

### COMPONENT VALUES

All resistors are ¼ watt, 5% unless otherwise indicated.

Part #	Value	Part #	Value	Part #	Value
R101	470 ohms	R19471		R422	10,000 ohms
R102	1,000 ohms	119102		R423	470,000 ohms
R103	120,000 ohms	119124		R424	24,000 ohms
R104	10,000 ohms	119103		R425	820 ohms, ½ watt
R105	470 ohms	119471		R426	5,600 ohms
R106	470 ohms	119471		R427	7,500 ohms
R107	18,000 ohms	119183		R428	47,000 ohms
R108	3,900 ohms	119392		R429	10,000 ohms
R109	15,000 ohms	119153		R430	470,000 ohms
R110	10,000 ohms	119103		R431	20,000 ohms
R111	100,000 ohms	119104		R432	820 ohms, ½ watt
R112	680 ohms	119681		R433	47,000 ohms
R113	100,000 ohms	119104		R434	10,000 ohms
R114	100,000 ohms	119104		R435	470,000 ohms
R115	10,000 ohms	119103		R436	20,000 ohms
R116	10,000 ohms	119103		R437	820 ohms, ½ watt
R117	5,100 ohms	119512		R438	7,500 ohms
R118	10,000 ohms	119103		R439	5,600 ohms
R119	100 ohms	119101		R440	20,000 ohms
R120	100 ohms	119101		R441	15,000 ohms
R121	2,200 ohms	119222		R442	470,000 ohms
R122	8,200 ohms	119822		R443	20,000 ohms
R126	620 ohms	119621		R444	820 ohms, ½ watt
R127	100 ohms	119101		R445	20,000 ohms
R128	150,000 ohms	119154		R446	15,000 ohms
R129	150,000 ohms	119154		R447	470,000 ohms
R130	1,000 ohms	119102		R448	20,000 ohms
R131	7,500 ohms	119752		R449	820 ohms, ½ watt
R132	390,000 ohms	119394		R450	15,000 ohms
R133	390,000 ohms	119394		R451	5,600 ohms
R134	1,000 ohms	119102		R452	10,000 ohms
R135	7,500 ohms	119752		R453	15,000 ohms
R136	3,300 ohms	119332		R454	470,000 ohms
R137	3,300 ohms	119332		R455	20,000 ohms
R138	47,000 ohms	119473		R456	820 ohms, ½ watt
R139	5,600 ohms	119562		R457	10,000 ohms
R140	5,600 ohms	119562		R458	15,000 ohms
R141	10,000 ohms	119103		R459	470,000 ohms
R142	360 ohms			R460	20,000 ohms
	5% 2 watt	110361		R461	820 ohms, ½ watt
R143	200,000 ohms	119204		R462	15,000 ohms
R144	100,000 ohms	119104		R463	3,000 ohms
R145	390,000 ohms	119394		R464	10,000 ohms
R146	2,200 ohms	119222		R465	15,000 ohms
R147	2,700 ohms	119272		R466	1,000,000 ohms
R201	1,000 ohms	119102		R467	20,000 ohms
R202	22,000 ohms	119223		R468	820 ohms, ½ watt
R203	33,000 ohms	119333		R469	10,000 ohms
R204	33,000 ohms	119333		R470	15,000 ohms
R205	4,700 ohms	119472		R471	1,000,000 ohms
R206	2,200 ohms	119222		R472	20,000 ohms
R207	2,200 ohms	119222		R473	820 ohms
R208	100,000 ohms	119104		R474	15,000 ohms
R209	100 ohms	119101		R475	1,500 ohms
R210	22,000 ohms	119223		R476	10,000 ohms
R211	6,200 ohms			R477	15,000 ohms
	5% ½ watt film	133622		R478	1,000,000 ohms
R212	220 ohms	119221		R479	4,700 ohms
R213	130 ohms	119131		R480	820 ohms, ½ watt
R214	150 ohms	119151		R481	10,000 ohms
R215	100 ohms	119101		R482	15,000 ohms
R216	22 ohms	119220		R483	1,000,000 ohms
R217	1,000 ohms	119102		R484	4,700 ohms
R218	2,200 ohms	119222		R485	820 ohms, ½ watt
R219	1,000 ohms	119102		R486	15,000 ohms
R220	39 ohms	119390		R487	680 ohms
R221	39 ohms	119390		R488	10,000 ohms
R222	2,400 ohms	119242		R489	15,000 ohms
R223	2,400 ohms	119242		R490	1,000,000 ohms
R224	10 ohms AB	109100		R491	1,500 ohms
R225	100 ohms	119101		R492	820 ohms, ½ watt
R226	100 ohms	119101		R493	10,000 ohms
R227	10 ohms AB	109100		R494	15,000 ohms
R228	1,000 ohms			R495	1,000,000 ohms
	5% 2 watt	110102		R496	1,500 ohms
				R497	820 ohms, ½ watt
				R498	15,000 ohms
				R499	240 ohms
R229	750 ohms	PART #			
	5% 2 watt	110751			
R230	300 ohms				
	5% 1 watt	116301			
R231	300 ohms				
	5% 1 watt	116301			
R232	750 ohms				
	5% 2 watt	110751			
R233	1,000 ohms				
	5% 2 watt	110102			
R235	47 ohms				
	5% ½ watt AB	103470			
R236	47 ohms				
	5% ½ watt AB	103470			
R237	47 ohms				
	5% ½ watt AB	103470			
R238	47 ohms				
	5% ½ watt AB	103470			
R239	1,000 ohms				
R240	1,000 ohms				
R244	200,000 ohms				
R245	39 ohms				
R246	39 ohms				
R247	330,000 ohms				
R301	10 ohms				
	5% 10 watt	110100			
R302	10 ohms				
	5% 10 watt	110100			
R303	10 ohms				
	5% 10 watt	110100			
R304	10 ohms				
	5% 10 watt	110100			
R305	1000 ohms				
	10% 10 watt	120102			
R306	10 ohms				
	10% 10 watt	120100			
R307	850 ohms				
	10% 10 watt	120851			
R308	850 ohms				
	10% 10 watt	120851			
R309	0.18 ohm				
	3% 10 watt	120180			
R310	0.18 ohm				
	3% 10 watt	120180			
R311	0.18 ohm				
	3% 10 watt	120180			
R312	0.18 ohm				
	3% 10 watt	120180			
R313	82 ohms				
R314	220 ohms				
R315	300 ohms				
R317	100,000 ohms				
	½ watt	102104			
R318	3.3 ohm ½ watt				
R319	10,000 ohms				
R320	10,000 ohms				
R321	18,000 ohms				
R322	600 ohms				
	5% 10 watt	120601			
R323	2,200 ohms				
	10% 10 watt	120222			
R401	150 ohms, 5% 1 watt				
R402	20,000 ohms				
R404	150,000 ohms				
R406	100,000 ohms				
R407	20 ohms				
R408	20,000 ohms				
R410	150,000 ohms				
R412	100,000 ohms				
R413	20 ohms				
R414	2,400 ohms				
R415	15,000 ohms				
R416	47,000 ohms				
R417	10,000 ohms				
R418	470,000 ohms				
R419	24,000 ohms				
R420	820 ohms, ½ watt				
R421	47,000 ohms				

		PART #		PART #		PART #		
R500	10,000 ohms	119103	C213	200 mfd 15v	283207	D302	silicon diode	
R501	15,000 ohms	119153	C214	200 mfd 15v	283207		1A 200prv 1N4003	544012
R502	10,000,000 ohms	119106	C215	.001 mfd 100v 10%		D304	zener diode	
R503	1,500 ohms	119152		disc	240102		13v 1w 5%	540113
R504	820 ohms, 1/2 watt	113821	C217	.001 mfd 100v 10%		D305	zener diode	
R505	10,000 ohms	119103		disc	240102		13v 1w 5%	540113
R506	15,000 ohms	119153	C218	1000 mmfd 100v 5%	255102	D401	silicon diode	
R507	10,000,000 ohms	119106	C219	.022 mfd 100v 10%	264223		1A 200prv 1N4003	544012
R508	1,500 ohms	119152	C220	.022 mfd 100v 10%	264223	D402	silicon diode	
R509	820 ohms, 1/2 watt	113821	C221	1000 mmfd 100v 5%	255102		1A 200prv 1N4003	544012
BR301	AC line breaker 15A	342702	C222	1000 mmfd 100v 5%	255102	D403	zener diode	
BR302	thermal sensor		C223	1000 mmfd 100v 5%	255102		12v 1w 5%	540012
	85°C 15A	342001	C301	.1 mfd 100v 20%		D404	zener diode	
BR303	thermal sensor			disc	224104		15v 1w 5%	540115
	85°C 15A	342001	C302	500 mfd 15v	283507	D405	zener diode	
BR304	AC line breaker 7A	342703	C303	500 mfd 15v	283507		15v 1w 5%	540115
BR305	thermostat		C304	10,000 mfd 80v	284109	D406	light emitting	
	55°C 15A	342007	C305	.1 mfd 100v 20%		thru	diode, red	546220
C101	4.7 mfd 15v 20%			disc	224104	D421		
	tantalum	282505	C306	10,000 mfd 80v	284109	DB301	silicon diode bridge	
C102	.01 mfd 100v 20%		C307	.1 mfd 100v 20%			25A	544504
	disc	234103		disc	224104	F301	fuse 5A 3AG	342025
C103	.01 mfd 100v 20%		C308	.1 mfd 100v 20%		F302	fuse 10A 8AG	342012
	disc	234103		disc	224104	F303	fuse 10A 8AG	342012
C104	12 mmfd disc	244120	C309	.01 mfd 500v disc	228103	IC101	IC NE5558	587458
C105	10 mfd 15v	281106	C401	500 mfd 25v	280507	IC102	IC LM301AH	587709
C106	.0082 mfd 100v 5%		C402	20 mfd 15v	281205	IC103	IC LM301AH	587709
	mylar	264822	C404	.15 mfd 100v 5%	265154	IC401		
C107	.0082 mfd 100v 5%		C406	.15 mfd 100v 5%	265154	thru	IC LM339	580339
	mylar	264822	D101	silicon diode		IC404		
C108	.47 mfd 100v 10%			1N4148	543148	L301	choke assembly	453001
	mylar	260474	D102	silicon diode		P101	470 ohms trimpot	140471
C109	.47 mfd 100v 10%			1N4148	543148	P201	1,000 ohms trimpot	190103
	mylar	260474	D103	dual silicon diode		P202	1,000 ohms trimpot	190103
C110	35 mfd 30v			BZ102	546361	P301	100,000 ohms	
	non-polarized	283366	D104	silicon diode			1/2 watt linear	142104
C111	5 mfd 15v	283505		1N4148	543148	PL301	neon lamp	521021
C112	5 mfd 15v	283505	D105	silicon diode		PL302	neon lamp	521021
C113	500 mfd 3v	281507		1N4148	543148	PL303	#53 lamp	526053
C114	50 mfd 10v	281506	D106	silicon diode		Q101	transistor EN3962	562962
C115	50 mfd 10v	281506		1N4148	543148	Q102	transistor SE4010	572010
C116	.01 mfd 100v 20%		D107	silicon diode		Q104	thyristor 2N5061	574061
	disc	234103		1N4148	543148	Q105	transistor FT4356	562356
C117	.01 mfd 100v 20%		D108	silicon diode		Q106	transistor 2N4889	562889
	disc	234103		1N4148	543148	Q201	transistor 2N4889	562889
C118	.47 mfd 100v 5%	260474	D109	silicon diode		Q202	transistor 2N4889	562889
C119	.47 mfd 100v 5%	260474		1N4148	543148	Q203	transistor 2N4889	562889
C120	.47 mfd 100v 5%	260474	D110	silicon diode		Q204	transistor 2N3440	572440
C121	.01 mfd 100v 20%			1N4148	543148	Q205	transistor 2N3440	572440
	disc	234103	D111	silicon diode		Q206	transistor 2N3440	572440
C122	.01 mfd 100v 20%			1N4148	543148	Q207	transistor 2N5415	562415
	disc	234103	D112	silicon diode		Q208	transistor BC308B	567070
C123	.01 mfd 100v 20%			1A 200 prv 1N4003	544012	Q209	transistor SE6020A	577021
	disc	234103	D113	silicon diode		Q210	transistor SE6020A	577021
C124	.01 mfd 100v 20%			1N4148	543148	Q211	transistor BC308B	567070
	disc	234103	D114	silicon diode		Q212	transistor TIP41C	577041
C125	200 mfd 3v	281207		1N4148	543148	Q213	transistor TIP41C	577041
C126	470 mfd 12v	283507	D201	silicon diode		Q214	transistor TIP42C	567042
C201	11 mfd 15v Kemet			1N4148	543148	Q215	transistor TIP42C	567042
	tantalum	281115	D202	silicon diode		Q301		
C202	.1 mfd 100v 20%			1N4148	543148	thru	transistor 2N5630	571104
	disc	224104	D203	silicon diode		Q304		
C203	.1 mfd 100v 20%			1N4148	543148	Q305		
	disc	224104	D204	silicon diode		thru	transistor 2N6030	561356
C204	.1 mfd 100v 20%			1N4148	543148	Q308		
	disc	224104	D205	zener diode		Q401		
C205	180 mmfd 100v 10%	224181		14v .4w 5%	540014	thru	transistor	577020
C206	.47 mfd 100v 5%	260474	D206	silicon diode		Q420	MPS A-20	
C207	1000 mfd 10v	281112		1N4148	543148	RY301	relay DPST	
C208	47 mmfd 500v 10%	224470	D207	silicon diode			15A 48v coil	539248
C209	.1 mfd 100v 20%			1N4148	543148	S101	switch 8PDT dual	338000
	disc	224104	D208	silicon diode		S301	switch DPDT	
C210	.001 mfd 100v 10%			1N4148	543148		rotary 15A	333241
	disc	240102	D209	silicon diode		S302	switch DP5T rotary	333025
C211	82 mmfd 100v 10%			1N4148	543148	S303	switch 2P4T rotary	333020
	disc	224820	D301	silicon diode		S304	switch 4PDT single	331105
C212	.001 mfd 100v 10%			1A 200prv 1N4003	544012	T301	power transformer	464026
	disc	240102				T302	power transformer, international model	464030

- 14( ) Prepare a 23" black wire. Connect one end to DS #9 (S-2).
- 15( ) Prepare a 23" red wire. Connect one end to DS #3 (S-2). Twist lightly together these red, green and black wires from DS, and pass the group under circuit board PC-29 between the control RV and the adjacent switch spacer.

All of the wires on the front panel which will subsequently connect to holes on the PC-29 circuit board will pass through this opening next to RV. However, for clarity in tracing individual wires, the pictorial diagram differs from actual placement by showing these wires going direct to the hole on the components side of the circuit board. In fact, *all* of these wires should come up *behind* (to the left of) the board, and be connected from the back (circuit side).

- 16( ) Prepare a 23" red wire. Connect one end to DS #6 (S-2).
- 17( ) Prepare a 2" black wire. Connect one end to DS #8 (S). Connect the other end to DS #2.
- 18( ) Prepare a 22" black wire. Connect one end to DS#2. (S-2). Twist this wire lightly together with the red wire from step 16, and place them under the circuit board with the previous group at RV. The pictorial diagram differs for clarity.
- 19( ) Prepare a 22" green wire. Connect one end to DS #7 (S).
- 20( ) Prepare a 20" red wire. Connect one end to DS #1 (S). Twist this wire lightly together with the green wire from step 19, and place them under the circuit board at RV. The pictorial diagram differs for clarity.
- 21( ) Select the red and green twisted pair from under the board at RV, and connect the red wire to hole #17 on PC-29 (S). Connect the green wire to hole #14 (S).
- 22( ) Select the red and black pair at RV and connect the black wire to hole #7 (S). Connect the red wire to hole #4 (S).
- 23( ) Select the red, green and black group at RV and connect the green wire to hole #3 (S). Connect the red wire to hole #2 (S). Connect the black wire to hole #1 (S).
- 24( ) Prepare a 5½" red wire and a 5½" black wire. Twist these wires *tightly* together uniformly throughout their length (about 3 full turns every 2"). Connect one end of the red wire to hole #21 (S). Form a small hook in the corresponding end of the black wire and squeeze it around the projecting terminal in hole #22. Keep it close to the board at the base of the terminal and *solder* this connection.

This was the first of 4 black wires which will be connected in like manner to this projecting terminal #22. As each wire is added, keep it close to the previous wire to allow room for other connections. It is best to solder each wire individually to be sure of a good ground connection, although the final step will indicate that all 4 wires are to be soldered. Do not use too much heat, or the terminal could be dislodged from the hole.

- 25( ) Connect the red wire of the short red and black twisted pair to RV lug #2 (S). Connect the black wire to RV lug #3.

- 26( ) Prepare a 9" black wire and a 9" green wire. Twist these wires *tightly* together as before, and connect the green wire to hole #23 (S). Connect the black wire to hole #22 (S). At the other end connect the green wire to LV #5 (S). Connect the black wire to LV #6. This pair should be placed against the front panel toward RV.

- 27( ) Prepare a 5¾" red wire. Also prepare a 5½" black wire, but remove the insulation from only one end. Start with the two prepared ends, and twist these wires tightly as before to within ¾" of the other end of the red wire. The small amount of remaining black wire should be twisted around the red wire to form a circle of insulated wire (the black wire acts as a shield for the red signal wire). Connect the black wire on the prepared end to hole #22 (S). Connect the red wire to hole #20 (S). At the other end, connect the red wire to control by-pass switch CS lug #4 (S).



The lugs on switch CS are more fragile than the other lugs in this kit. Do not attempt to bend a hook in the end of the wire before inserting. Simply push the straight wire end in the lug hole, solder, and then cut off excess wire.

- 28( ) Prepare an 8" green wire. Also prepare a 7¾" black wire, but remove insulation from only one end. Twist these wires tightly as before to within ¾" of the other end of the green wire. Twist the black around the green wire to form a circle. Connect the black wire on the prepared end to hole #22 (S-4). Connect the green wire to hole #19 (S). At the other end, connect the green wire to CS lug #1 (S). Position these wires against the front panel toward CS.
- 29( ) Strip about ¾" of wire bare from the roll of black wire. Feed the bare wire through CS lug #6 to CS lug #12, solder both, and cut the excess wire.
- 30( ) Similarly connect CS lug #3 to CS lug #9. Solder both, and cut the excess wire.
- 31( ) Prepare a 2½" red wire. Connect one end to RV lug #1 (S). Connect the other end to CS lug #10 (S). Position this wire away from the front panel.
- 32( ) Prepare a 3" green wire. Connect one end to LV lug #4 (S). Position this wire against the front panel, and connect the other end to CS lug #7 (S).
- 33( ) Prepare a 12" green wire. Pass one end under the board at RV and connect it to hole #16 (S). Connect the other end to DL lug #2 (S).
- 34( ) Prepare a 13½" black wire. Pass one end under the board at RV and connect it to hole #13 (S). Connect the other end to DR lug #4 (S).
- 35( ) Prepare a 16" green wire and an 18" black wire. Start with two ends even, and twist these wires lightly together to within 3" of the other end of the green wire. With the uneven ends near the center of the panel, pass the even ends under the board at RV, and connect the green wire to hole #11 (S). Connect the corresponding end of the black wire to hole #10 (S).



- 36( ) Select a wire tie. Group together the twisted pair from the previous step, the red-black twisted pair from LS, and the single black and single green wires from DL and DR. Tie these 6 wires together on the left side of DL. Cut off the excess tie.
- 37( ) Prepare a 2<sup>3</sup>/<sub>4</sub>" white wire. Connect one end to power switch PS lug #1 (S). [Ignore any numbers on the switch itself.] Connect the other end to TL lug #1 at the base (S).
- 38( ) Prepare a 2" white wire. Connect one end to PS lug #2 (S). Connect the other end to TL lug #3 at the base (S).
- 39( ) Strip about 1<sup>1</sup>/<sub>2</sub>" of wire bare from the roll of black wire. Feed the bare wire through TL lug #1 at the tip to TL lug #2 at the tip, and cut the excess wire.  
NOTE: Skip this step if the international transformer #464030 is used, and to be wired for 200, 220 or 240 volts AC.
- 40( ) Similarly connect TL lug #3 at the tip to TL lug #4 at the tip. Cut excess wire.  
NOTE: If this amplifier uses the international power transformer, part #464030, and is to be wired for either 200, 220 or 240 volts AC, connect a 100,000 ohms resistor (brown-black-yellow) in place of this short piece of wire.
- 41( ) Connect one lead from neon lamp HL to TL lug #4 at the tip (S-2).
- 42( ) Connect one lead from lamp PL to TL lug #2 at the tip (S-2).  
NOTE: If the international transformer #464030 is used, and is to be wired for either 200, 220, or 240 volts AC, also prepare a 5" black wire, and connect one end to TL lug #2 at the tip (S-2). Connect the other end to PC-30 hole #9 (S).
- 43( ) Connect the remaining lead from each lamp to TL lug #5 at the base (S-2).
- 44( ) Prepare a 2" white wire. Connect one end to PS lug #6 (S). Connect the other end to PS lug #3. Although another wire will be connected to lug #3, we suggest soldering it now.

#### CHASSIS-FRONT PANEL AND CHASSIS-HEAT SINK ASSEMBLY

Now place the main chassis and the front panel in their approximate positions, with the front panel laid flat. The twisted groups of wires previously tucked under the chassis should be brought above the panel. Select 2 black #6 self-tapping screws, and loosely fasten the edges of the chassis to the front panel. Since these screws cut their own threads and the panel hole is smaller, some force is required. This will help keep things stable while making connections.

- 1( ) Prepare a 9<sup>1</sup>/<sub>2</sub>" red wire. Connect one end to PC-30 hole #20 (S). Connect the other end to DR lug #3 (S-3).
- 2( ) Select the white wire from the circuit breaker from under the power transformer. Connect it to PS #3 (S-2).
- 3( ) Strip a 1" piece of white wire bare. Form it into a "U" <sup>1</sup>/<sub>2</sub>" wide, and connect it between PS #4 and PS #5. Solder both lugs.
- 4( ) Select the free end of the line cord from under the power transformer, twist the strands together and tin them, form a hook in this end, and connect it to

the link of wire between PS lugs #4 and #5. (S). Make sure that there is *no possibility* for any bare leads to touch the wrong terminal on the switch, or any part of the front panel.

- 5( ) Select the fan cord with the special socket, and cut the cord to 14". Feed the free end of the cord through the access plug behind the power transformer, and under the transformer along the right chassis edge to the front. Separate the 2 conductors of the cord for about 1<sup>1</sup>/<sub>2</sub>", prepare their ends, and twist the strands of each wire together. Connect one conductor to TL lug #3 at the tip, and the other conductor to TL lug #6 at the base (S).
- 6( ) Select the pair of twisted red wires from terminal strip FT under the large capacitors, and connect the shorter wire at the free end to TL lug #1 at the tip. Connect the other wire to TL lug #6 at the tip. (S).

The following 2 steps describe the wiring for the standard power transformer, part #464026. When the international power transformer, part #464030, is installed, even if it is presently to be wired for 120 volts, the wiring will differ because of the additional leads. Instructions for wiring it will be found on page 35 of this manual, and these should be followed now in place of the following 2 steps.

Transformer leads may be shortened for neatness if you wish. However, be sure you do not cut them too short for reuse, especially if an alternative line voltage connection may be needed in the future.

- 7( ) Twist tightly together the strands of the black [1] transformer lead and tin them with solder. Connect this lead to TL lug #1 at the tip (S-3).
- 8( ) Twist together and tin the strands of the black/white [2] transformer lead, and connect it to TL lug #5 at the tip. Another wire will connect to this lug, but you may wish to solder it now.
- 9( ) Pass the red, black and green group of wires from the PC-30 power supply board under PC-29 at RV, and connect the green wire to hole #18 (S). Make sure this wire is soldered to the circuitry on *both* sides of the board. Connect the black wire to hole #15 of PC-29 (S). Connect the red wire to hole #12 (S). Make sure this wire also is soldered to the circuitry on *both* sides of the board.
- 10( ) Pass the red and green pair of wires from the rear terminal strip on the relay mounting plate, under the plate and under PC-29 at RV, and connect the red wire to hole #6 (S). Connect the green wire to hole #5 (S). The pictorial diagram differs for clarity.
- 11( ) Pass the red and black pair of wires from the relay and front terminal strip under PC-29 at RV, and connect the red wire to hole #9 (S). Connect the black wire to hole #8 (S). The diagram differs for clarity.
- 12( ) Pass the red and black pair of wires from the switch LS under the relay plate between the C1 and C2 capacitors, and connect the red wire to LT terminal lug #4 on the relay mounting plate. Connect the black wire to LT terminal lug #5. A later connection will be made to each of these terminals, but we suggest that you solder the wires now for security.

- 13( ) Select a wire tie. Group together the twisted pair from the previous step, as well as the other wires running across the bottom of the front panel and under PC-29. Tie them together on the left side of the small rectangular panel opening.

Select the heat sink assembly and make one final check of its wiring, and all solder connections for a smooth, shiny flow of solder. Check particularly the orientation of the 4 diodes.

Set the heat sink in its approximate position (with the circuit boards facing you, and to your left) at the rear of the chassis. Place the protruding wires approximately as follows:

The long white pair down along the chassis between C2 and the large brace, and then under the wires to PC-30, and up to the right.

The pair of blue wires, and the pair of black wires under the relay plate, and around C2 to the ground lugs. These are long for future service access.

The single yellow wire, and the single white wire under the relay plate and across the front panel.

The 3 pairs of heavy wires (blue and white, blue and yellow, yellow and white) over the top of the relay plate.

The red pair under the relay plate to terminal FT.

The four pairs of lighter wires (2 each red and black, green and black) around the outside of C1 and across the front panel to the left of PC-29.

- 14( ) Select the pair of red wires under the relay plate. Connect the shorter wire end to terminal FT lug #1 at the tip (S). Connect the other wire to terminal FT lug #5 at the tip (S). Excess length should be stored between the 2 large capacitors.

*NOTE:* If this amplifier uses the international power transformer, part #464030, and is wired for either 200, 220, or 240 volts AC line, do not yet solder FT lug #5 at the tip. Now select the the 2200 ohm (2.2 K), 10 watt resistor, trim each lead to 3/4", and bend the leads more than 90° to its body. Mount the resistor atop the 600 ohm, 10 watt resistor, and connect one lead to FT lug #2 at the tip (S). Connect the other lead to FT lug #5 at the tip (S-2).

- 15( ) Select the pair of blue wires, and the pair of black wires under the relay plate. Connect all 4 wires to ground lug L2, and solder each very carefully. There are now 5 wires soldered to this lug.

- 16( ) Select the long pair of white wires. Connect one wire to TL lug #3 at the tip (S-3). Connect the other wire to TL lug #5 at the tip (S-2). Place these wires down near switch DS and to the left of the diode block. Excess length should be stored at the rear.

- 17( ) Select 2 wire ties. Group together the white pair from the previous step, as well as the other wires running across the bottom of the front panel. Tie them together to the left of switch DS, and also in front of ground lug L1. Cut excess ties.

- 18( ) There is a single white wire and a single yellow wire under the relay plate. Do not confuse these with the

single white and yellow wires attached to front terminal LT, which already have terminal clips installed. Select the 2 wires from under the relay plate and a terminal clip. Install a clip on the white wire (S). Select the green and black pair on the front panel whose other ends are connected to PC-29 (do not confuse them with the green and black pair from switch LS). Connect the green wire to the terminal clip you have just mounted on the white wire (S).

- 19( ) Select the single yellow wire from under the relay plate and pass it behind and to the right of the blue and yellow wires connected to the relay front terminal LT. Select a terminal clip, and install it on this yellow wire. (S). Select the black wire from the black and green pair, and connect it to this terminal clip as well. (S).

- 20( ) Select the blue and yellow pair and connect the yellow wire to fuse block lug #5 (S-2). Connect the blue wire to fuse block lug #6 (S).

- 21( ) Select the white and yellow pair and connect the yellow wire to LT lug #5 (S-4). Connect the white wire to LT lug #4 (S-4).

- 22( ) Select the blue and white pair and connect the white wire to fuse block lug #2 (S). Connect the blue wire to fuse block lug #1 (S).

- 23( ) There are 2 red and black twisted pairs. Select the pair from grommet G2 (not from the right channel PC-28). Connect the red wire to CS lug #11 (S). Connect the black wire to RV lug #3. Be careful not to burn the insulation on adjacent wires.

- 24( ) Select the red and black pair from right channel PC-28 holes 1 and 2, and connect the black wire to RV lug #3 (S-3). Connect the red wire to CS lug #5 (S).

- 25( ) Of the 2 green and black pairs, select the pair from grommet G2 and connect the green wire to CS lug #8 (S). Connect the black wire to LV lug #6.

- 26( ) Select the green and black pair from left channel PC-28, and connect the black wire to LV lug #6 (S-3). Connect the green wire to CS lug #2 (S).

Now is a good time to check that each lug on CS is soldered, that there are no solder runs or blobs and that any excess wire ends are cut short. Lugs #3 and #9 are connected together, as are lugs #6 and #12. Each other lug connects to a single wire.

- 27( ) Select the remaining 2 wire ties. Group together the 4 pairs of green and black, and red and black wires from G2 and the PC-28 boards. Tie them together in front of the left side of left channel PC-28, and also adjacent to the left front foot. Cut excess ties.

Check to make sure the 5 brackets under the heat sink are positioned properly for mounting. The bracket on the left faces outward, and the others downward. *Make certain that no wires are likely to be pinched between the chassis and the heat sink rib, and that there are no loose pieces of wire or solder under the heat sink. Be very careful of components on the circuit boards.* Place the extra length of the white wire pair behind the power transformer, and position the other wires down against the chassis. Slide the heat sink forward

into position so that the back rib is flush with the edge of the chassis, and see if the holes in the brace align with holes in the heat sink. If not, either support the chassis underneath in the center to counteract bowing from transformer weight, or shift the transformer slightly if it is interfering with the brace. In the next step, a screwdriver with at least a 5/16" shaft should be used.

- 28( ) Select two #6 SEMS screws (lockwashers attached). Slide the heat sink 1/4" to the rear to enable you to install the screw in the lower hole of the brace. Hold it in position with the screwdriver as you slide the heat sink forward to engage the screw (make certain that you do not pinch any wires under the heat sink). Once the lower screw is started, use the same technique to hold the upper screw until it is started. Do not yet fully tighten these screws.
- 29( ) Select 2 more #6 SEMS screws. Use these to attach the line cord Z-bracket to the heat sink. You may need to first loosen the 2 screws holding the bracket to the chassis. Tighten all these securely.
- 30( ) Select two #8 SEMS screws. Install these at the other end of the heat sink through the edge of the chassis, and tighten.

### FINAL ASSEMBLY

Handle the PC-48 board with particular care to not disturb the long leads of the 16 Light Emitting Diodes. The numbers of the six connecting holes along the top edge are printed only on the front (component) side. You may wish to mark each number on the back (foil) side of the board adjacent to the hole to identify them easily from the back.

Position the twisted pair of red and black, and green and black wires away from the large rectangular hole in the front panel until they are connected to PC-48.

- 1( ) Select the PC-48 board, the 3 plastic tubular spacers, the three 1" #4 screws, and the remaining three #4 nuts. The board mounts over the large rectangular hole so the numbered holes are at the top and the LEDs point through the opening. Insert the screws from the outside, slip a spacer over a screw on the inside, followed by the board, and finally a nut on each screw. Tighten the hardware.
- 2( ) Select the green and black pair from switch LS, and connect the green wire to PC-48 hole #1 (S). Connect the black wire to hole #2 (S).
- 3( ) Select the red and black pair from LS and DR, and connect the black wire to hole #3 (S). Connect the red wire to hole #5 (S).
- 4( ) Prepare a 14 1/2" black wire and a 14 1/2" green wire, and twist them lightly together. Connect the black wire at one end to PC-30 hole #18 (S). Connect the corresponding end of the green wire to PC-30 hole #15 (S). Position this pair down to the bottom of the front panel and twist it 2 times around the single red wire connected between PC-30 hole #20 and DR lug #3; also twist it once around the red and black pair connected to PC-48. At the other end, connect the black wire to PC-48 hole #4 (S). Connect the green wire to hole #6 (S). Note that holes #3 and #4 represent a common connection.

- 5( ) Select the 2 small #53 light bulbs and install them in DL and DR. They simply push in and turn.

Now is the time to carefully examine the chassis and front panel to remove any loose pieces of wire or solder. If you feel ambitious, you can first complete the next 2 steps, and then pick the amplifier up, turn it over, and shake out any loose particles!

You (or preferably someone else) should check out every visible connection against the pictorial diagram. Make one last critical check of all solder connections for a smooth, shiny, unbroken flow of metal. Also make sure that none of the finned heat sinks on transistors located on the boards can contact one another, or that components have been moved so that there is any possibility of contact between adjacent bare leads.

- 6( ) Check to make sure that the terminal clips are all securely installed on the diode block, and that there are no wires close to the relay where they may impede its operation. Make sure all of the twisted groups of wires along the front panel are positioned along the lower edge where they will be clear of the long opening near the bottom of the panel. Select the 2 yellow wires with terminal clips installed (one with a black wire attached) and push them through the long opening to the right of lamp DR. Push the two white wires (one with green) with terminal clips through the opening to the left of lamp DL. Fold the cardboard insulator over the switch PS. Swing the panel upright, making sure that no wires are pinched between the panel and the chassis. Watch that the twisted pairs of wires to the PC-29 board do not interfere with any components on the PC-28 boards. Select 2 #6 SEMS screws and secure the front panel to the vertical chassis brace. Tighten these, and both screws at the back of the brace into the heat sink as well.
- 7( ) Tighten the two #6 sheet metal screws at the ends of the front panel. Check to be sure that no wires near the power switch or the control RV can be pinched by these screws with their sharp threads.
- 8( ) Select the decorative front plate, the dark rectangular plastic insert, and the two lengths of rubber stripping. Cut the stripping to fit the length of the plastic insert, and remove the protective backing to expose the self-adhesive side. Apply one piece to each back flange of the insert as shown, and install the insert from the back side of the front plate.

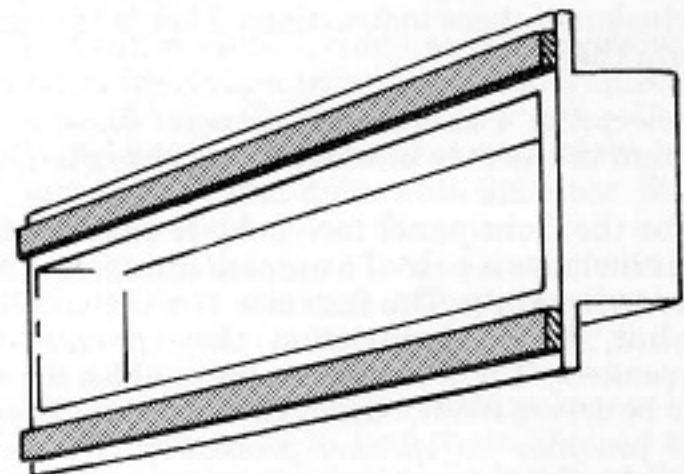

- 9( ) Select the 2 square black plastic fuse holders. Note that one face is designated "top". With this surface facing the top edge of the front plate, install each fuse holder from the *front* of the plate so that it snaps into position. The caps will be installed later.
- 10( ) Bring the front plate close to the front panel and install the 4 terminal clips on the fuse holder lugs while pressing against the front surface of the holder to prevent it from being dislodged:  
 The white + green to lower lug of left channel;  
 The white to upper lug of left channel;  
 The yellow + black to lower lug of right channel;  
 The yellow to upper lug of right channel.
- 11( ) Carefully align the 16 LEDs and the 2 neon lamps with the front plate openings and install the front plate in its final position. Check to make sure that the white wires to the left channel fuse holder do not get pushed back to where they can interfere with the operation of the relay. Do not scratch the LEDs.
- 12( ) Select the 2 flat handles, the four 1/2" diameter spacers, the four 1 3/4" #10 screws with *flat* heads, and the larger L-shaped Allen wrench. Insert a screw through each hole in the handle so the head of the screw will be flush with the handle. On the other side, slip a spacer over the screw, pass the screw through a hole near each corner of the front plate, and fasten it loosely to the steel front panel. Again check the alignment of the front plate, and carefully but securely tighten all 4 screws with the Allen wrench.
- 13( ) Select the 3 push buttons. Press them onto the switch shafts. If they seem loose, a small amount of rubber (paper) cement on the shaft will keep them tight without making them impossible to remove.
- 14( ) Select the 4 large and the 1 small knob, the 5 Allen set screws, and the smaller Allen wrench. Install the set screws in each knob by first placing the set screw on the end of the wrench for easier handling. The set screw engages the flat portion of the shaft of each control or switch. The small knob fits over the shaft for LED range. Push each knob fully onto the shaft, and then pull it back slightly so that it will not press against the front plate and scratch it in use. Be careful not to scratch the front plate as you tighten each screw securely.

If you have access to a vacuum tube voltmeter, transistorized voltmeter, or a volt/ohm/milliammeter with a sensitivity of at least 20,000 ohms per volt, there are some measurements which can be made to verify basic operational integrity. These are described under "Preliminary Tests" at the conclusion of these instructions. Now is the easiest time to perform them.

- 15( ) Select the 4 shorter (10 ampere) fuses and install them in the fuse blocks on the relay plate.
- 16( ) For the front panel fuse holders (speaker fuses) the kit includes a pair of 5 ampere rating, and a pair of 1 ampere rating. The fuse size you use will determine what, if any, protection they provide for your speakers. The 5 ampere value enables the amplifier to be driven to full output for 8 ohm and 16 ohm tests. It provides *no speaker protection*. We recommend you install the 1 ampere size, and read the section of this manual covering this matter in depth. Select the

two fuse holder caps, snap the appropriate fuse into the cap, and insert it with the lettering upright, pressing against the *upper half* of the cap. (To remove the fuse, press the lower portion of the cap.) The cap snaps securely into position when fully seated.

- 17( ) Select 4 #6 SEMS screws and the black cover. The back lip of the cover stays forward of the heat sink and the upright portion of the line cord Z-bracket. The side flanges go inside the upturned chassis sides. Install the screws through the sides of the chassis.
- 18( ) Select 8 black #6 short self-tapping screws and install them around the front edge of the cover.
- 19( ) Select 2 more black #6 self-tapping screws and fasten the vertical portion of the Z-bracket to the back of the cover.
- 20( ) Be careful not to rest the weight of the amplifier on the output binding posts at the rear. Turn the amplifier over and install the 8 remaining #8 SEMS screws to secure the heat sink, and the 4 last #6 black short self-tapping screws to fasten the front panel. Now turn the unit right side up.
- 21( ) Select the fan assembly and the 2 remaining #6 SEMS screws. Position the assembly near its final location on top of the line cord Z-bracket, and plug the special fan cord socket into its mating connection on the fan. Fasten the fan assembly securely to the side of the chassis with the hardware. The large hole in the fan bracket should clear the single screw on the rear side of the chassis. Finally check to see that the head of the arrow indicating air flow is toward the heat sink.
- 22( ) Make sure the back heat sink fin surface and the right chassis side are clean. Remove the paper backing from the self-adhesive long metallic label, and affix it to the portion of the fin just above the curve at the base. Remove the backing from the serial number label and center it above the other label. Remove the backing from the C-100 accessory warning label and affix it on the side next to the heavy duty socket.

This completes the assembly. You may wish to keep the Allen wrenches for future needs. Be sure that you read the entire section on operating instructions before connecting this amplifier to speakers. A unit of such power is quite capable of damaging *any* loudspeaker if it is improperly used.

## PRELIMINARY TESTS

The availability of a VTVM, TVM, or VOM with at least 20,000 ohms per volt sensitivity will enable you to make some checks to minimize the likelihood of trouble. Since each PC-28, PC-29 and PC-48 circuit board has been checked in actual operation prior to packing into the kit, a component fault there is most unlikely. However, a splash of solder, poor or wrong connections, or broken or shorting component leads can result in failure. These tests can help prevent a minor construction error from causing a costly major breakdown.

All of the following checks should be made *before the amplifier is turned on*, and with all of the 6 fuses (4 power supply; 2 speaker) out of the circuit.

1. From fuse block lugs #1, 2, 5 and 6 (amplifier heat sink side) to ground: 2900 ohms  $\pm$  150 ohms.
2. From each PC-28 hole #7 to ground: 900 ohms  $\pm$  150 ohms.

Some meters may indicate lower readings. Or, reversing the meter leads may give a proper reading. As a rule, so long as neither a short circuit nor an open circuit is indicated for these tests, you may proceed.

If these checks are satisfactory, plug in the amplifier. Turn the power switch to either "on" position for the following DC voltage checks. If an incorrect measurement is obtained, be sure to turn off and *unplug the amplifier* before proceeding further.

3. From fuse block lugs #3 and 4 (white wire) to ground: +74 volts  $\pm$  2 volts.
4. From fuse block lugs #7 and 8 (yellow wire) to ground: -74 volts  $\pm$  2 volts.
5. From PC-29 hole #18 to ground: +13 volts  $\pm$  1 volt.
6. From PC-29 hole #12 to ground: -13 volts  $\pm$  1 volt.

If all of these are satisfactory, *unplug the amplifier* and complete final assembly steps.

If an incorrect measurement is obtained, refer to "In Case of Difficulty" before proceeding further.

## TECHNICAL INFORMATION

### IN CASE OF DIFFICULTY

If your Stereo 416 passes all the preliminary tests, and appears to function satisfactorily, you can usually assume it is meeting all of its specifications. If difficulties are encountered in a unit as complex as this, the average kit builder should confine his servicing to the basic suggestions given here, and if a suitable meter is not available you should attempt *only* the most rudimentary check-out yourself. **DO NOT ATTEMPT TO SERVICE THIS AMPLIFIER UNLESS YOU HAVE THE KNOW-HOW AND SUITABLE TEST EQUIPMENT.**

Because 90% of the difficulties which are encountered in kit-built units can be attributed to incorrect wiring or a poor solder connection, it is strongly recommended that you ask someone else to check your wiring against the pictorial diagram, as frequently one person will make the same error repeatedly.

There are certain general precautions to be observed in servicing any transistorized equipment:

1. Never make circuit changes of any kind when the amplifier is turned on.
2. Be particularly careful not to short any transistor leads to each other or to the chassis when the power is on.
3. When using test equipment, you must avoid transient voltage peaks and excessive test voltages.
4. Exercise caution when soldering and unsoldering transistor and diode leads to avoid excessive heat.

### Failure in Preliminary Tests

**Test #1** If a short circuit is indicated, remove the wires to PC-28 holes #4 and 15 of the suspect channel. If the same low reading is obtained, the heat sink assembly is faulty, and you should check the power output transistor sockets for shorts, a missing insulator, or other improper mounting. If an open circuit is obtained, check the PC-28 board.

If the test indicates too high a resistance, miswiring or a poor solder connection is likely.

**Test #2** If the measurement is very low, remove the wire from the hole, and check for the proper 900 ohm resistance from the wire to ground. If it is now correct, check PC-28 for faults. If the measurement is still low, check the heat sink wiring.

If a high reading is obtained, check the heat sink wiring and also the main ground connection at the base of C2 for poor contact.

**Tests #3, 4, 5 and 6** Incorrect values require checking the power supply wiring (the power transformer, diode block, and PC-30) and in particular the orientation of the diodes and capacitors on PC-30. Check for good connection *across* all of the PC-30 holes, including those supporting the resistors.

If *Test #5 or 6* measures low, unsolder the wire from the hole. If the voltage on the wire is now normal, check PC-29 for solder splashes, etc. Continued low reading is cause to recheck PC-30.

### No Sound Output

A blown speaker fuse is the most likely cause of interrupted sound on one channel. If the fuse is replaced, and input and output connections are secure, and the level control is clockwise, check the internal audio wiring for short circuits. These are the twisted pairs from the input sockets (through the center heat sink grommet) to the level controls, then to holes #21, 22 and 23 on PC-29, and from holes #19 and 20 to PC-28 holes #1 and 2.

To ascertain if the amplifier is at fault, first interchange the speaker connections at the amplifier output to eliminate a defective speaker or faulty wiring. If the problem does not "follow" the speaker, then interchange the input cables at the back of the amplifier. If the effect then switches channels, it is in the associated equipment or cables ahead of the amplifier.

If there is no sound on either channel, and the pilot lamp is out, reset the red circuit breaker button on the back. If the breaker pops again, do not attempt to reset it before servicing.

If a thermal sensor has shut down the amplifier, the Hi-Temp lamp will light unless it is defective, but a thermal sensor will reset itself after a couple of minutes.

If the "click" of the relay is not heard soon after the power is switched on, unplug the amplifier and check the 4 power supply fuses. If they are intact, check out the relay wiring, and make sure that none of the wiring can physically interfere with the operation of the relay. Then turn the unit on and measure the DC voltage on PC-29 holes #10 and 11. If hole 11 exceeds  $\pm 0.5$  volt, check the wiring of the left channel. If hole 10 exceeds  $\pm 0.5$  volt, check the wiring of the right channel.

If a power supply fuse is open, make the preliminary tests *before replacing the fuse*. When one of these fuses fails, it is most likely that further service is required, and simply replacing the fuse may compound the problem.

## Momentary Sound Interruption

Short duration interruption of the signal on both channels is very likely to be caused by the relay speaker protection circuit. As supplied, it is designed to trip on an output DC threshold of 1½ volts, for it thus affords some speaker protection against the more violent sonic abuses of dropped tone arms, warped records, tuner muting circuits, etc., in addition to protection against DC offset damage.

We feel such protection is mandatory in a high power amplifier. Should you wish even more DC offset protection, change the value of two resistors on PC-29 (R31 and R35 now are 7,500 ohms [violet-green-red]). Changing both to 12,000 ohms will increase sensitivity to 1 volt; changing both to 27,000 ohms will provide ½ volt DC sensitivity.

Frequent relay actuation is cause to suspect malfunction or severe input signal problems. If hole #7 of PC-28 is not at zero DC, P1 can make small corrections. More than 200 millivolts with no input signal indicates likely amplifier malfunction.

## SERVICE INFORMATION FOR THE TECHNICIAN

(FOR QUALIFIED PERSONNEL ONLY)

Proper disassembly will contribute measurably to efficient servicing. The lengths of wire connecting separate portions are long enough to permit servicing access without disconnection. While the factory assembled units may not follow the color code employed in the kit, the pictorial diagram which is a part of this manual may also aid the technician.

Most of the information of help to the technician will be found in the detailed circuit description and its accompanying block diagrams in this manual. You should also familiarize yourself with the sections "Preliminary Tests" and "In Case of Difficulty." Voltage test points for the circuit boards will be found at the back of this manual. The parts list for the schematic diagram follows it in the center of the manual.

## Disassembly

1. Remove the perforated cover: 8 black screws; 2 screws at each end; 2 black screws at the right rear above the line cord (to get at these, remove the fan—2 screws on the side—and then unplug the fan).
2. Remove the decorative front plate: a 1/16" Allen wrench for the 5 knobs; a 1/8" Allen wrench for the handle assemblies; then slide the front plate forward until the clips can be removed from the front panel fuse holders. Squeeze the sides of the fuse holders to remove them from the front plate for reconnection to the output leads.
3. Lower the inner front panel: loosen the black screw at each end; remove 4 more underneath, and the 2 screws securing the front panel to the vertical brace.
4. Remove the heat sink assembly: 2 rows of 4 screws under the rear of the chassis; 2 screws on each end; 2 screws through the vertical brace (a screwdriver with a 5½" shaft is needed here).

## Servicing and Adjustments

It is recommended that while service work is being performed on one channel, the other channel be disconnected by removing the appropriate power supply fuses to minimize the risk of damage. If any supply fuses are found to be open, all eight output transistors for that channel should be checked. A fault on the PC-28 board is cause to check all its suspect transistors with in-circuit resistance measurements. If those tests are inconclusive, each should be pulled out and checked with a transistor tester.

The recommended procedure for reconnection of a channel is: 1) Connect an 8 ohm test load to the output jacks, with *no input* signal. 2) Raise the AC to 120 volts gradually with a variac. Insert the B- fuses on the right side of the relay mounting plate. Monitor the B+ current with a meter in place of the left side fuse(s) on the mounting plate, and adjust the bias on each channel with P202, which should be able to vary the current from 100 to more than 175 ma. Operate for 10 minutes, then adjust P202 for minimal crossover distortion at 2 watts output. Alternatively, set for 175 ma. Be careful that meter connections are secure, and cannot short. Install B+ fuses. 3) Adjust the DC centerline voltage for each channel with P201 for 0 volts ( $\pm 20$  millivolts) at the output. 4) Now apply a signal and monitor it with an oscilloscope. At 200 watts output (into 8 ohms), a 1000 Hz sine wave should draw about 2 amperes. If all measurements check, the 200 watt output should be shorted for 5 seconds to ensure proper protective circuit functioning. The current reading should hold at about 2 amperes during the shorted output test.

## Checking Semiconductors

An ohmmeter can sometimes serve as a gross check for transistor or diode failure. The device must be removed from the circuit. Diodes should have a high resistance in one direction (probe polarity) and a low resistance in the other.

Transistor types vary widely in resistance, but a (near) short circuit indicates probable failure. Readings from base to collector should be similar to those from base to emitter. Both will have a higher reading with one probe polarity than with the reverse orientation. NOTE: Some types of solid state meters do not provide enough probe voltage to forward bias a silicon junction. Hence, a high resistance reading may be obtained in both directions.

Such gross checks can only ascertain clearly faulty semiconductors. More sophisticated test equipment, or direct substitution is necessary to qualitatively evaluate their performance.

## PERFORMANCE TESTING

The intention to test an amplifier of this power potential assumes a requisite level of technical competence and familiarity with the proper equipment. High power tests, and any distortion tests, require larger output fuses than those normally used. A minimum 5 ampere rating is needed for 8 ohm loads; 9 amps for 4 ohms; and 3 amps for 16 ohms. For mono full power tests at 8 ohms, a 9 ampere fuse is needed in each channel.

Prolonged high power test signals at low impedance at some frequencies may eventually trigger the thermal cutout even though the heat sink may be fan cooled and does not appear unduly hot. The thermal sensors are mounted on the transistor cases for quick response, and under some conditions the case cannot transfer the heat to the sink fast enough, especially if the amplifier is already hot when the test begins. The thermal sensors shut the amplifier off when they reach 85°C.

The power supply with its low loss transformer has a high degree of inherent regulation, but since up to 17 amps is drawn, the voltage drop off the line may be appreciable, especially if a variac is used. Thus the AC line must be corrected to 120 volts (measured on an rms reading meter) during high power testing.

The relay circuit will be triggered at relatively low powers below 10 Hz because the longer duty cycle appears as DC to the protective circuit. The amplifier has considerably greater power capability at sub-sonic frequencies than the protective circuits nominally pass.

## SQUARE WAVE PERFORMANCE AT 200 WATTS

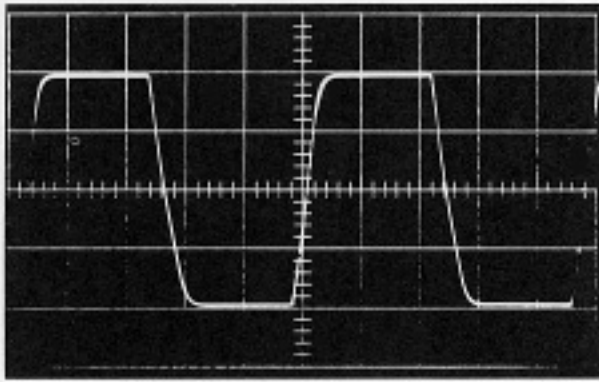

20 KHz, 200 watts

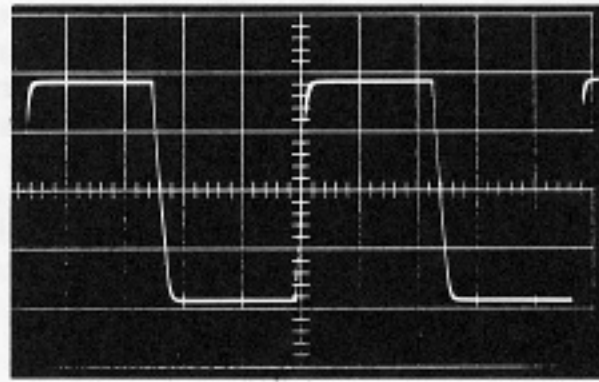

10 KHz, 200 watts

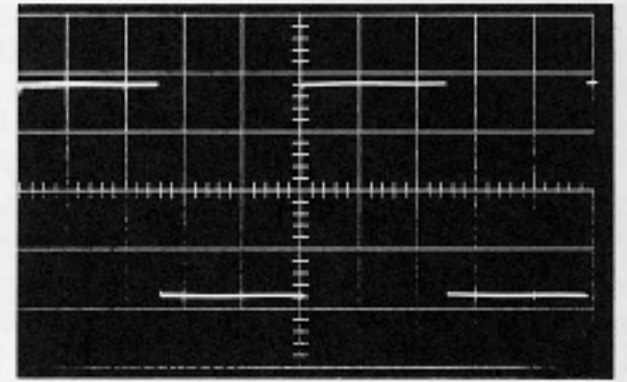

1000 Hz, 200 watts

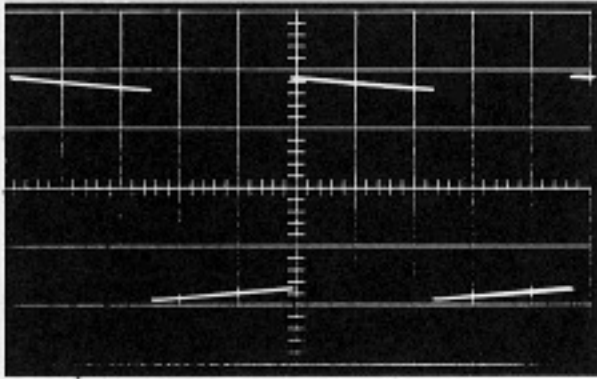

100 Hz, 200 watts

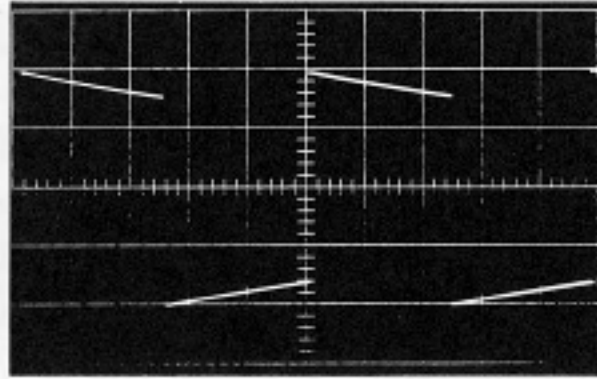

50 Hz, 200 watts

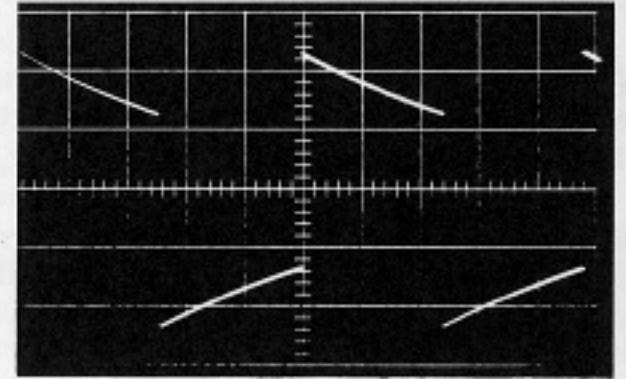

20 Hz, 200 watts

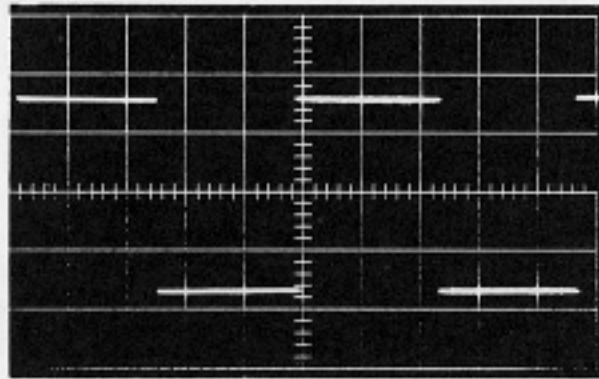

100 Hz, 200 watts  
protective rolloff removed

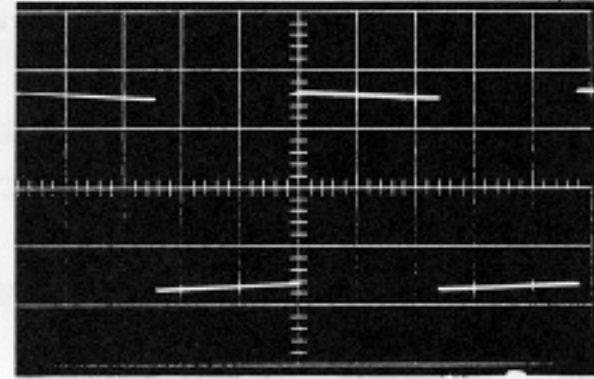

20 Hz, 200 watts  
protective rolloff removed

### 200 WATT SQUARE WAVE CAPABILITY

These photographs are remarkable, for they demonstrate performance beyond the capability of most amplifiers. Usually, square wave performance is reported only at *one watt*, for high power tests will show ringing, if not outright oscillation on a high frequency square wave, and often outright failure of the amplifier on 20 Hz full power square wave attempts. Low power square waves can only look even better than these, which are truly state-of-the-art. Adequate square wave representation requires band-width in excess of 1/10th to 10 times the displayed frequency, so these demon-

strate linearity *at full power* from a few Hertz to almost 100,000 Hz.

To show *for informational purposes only* the inherent low frequency capability of the power amplifier, we have removed the protective rolloff circuitry in the last two photographs to show nearly perfect full power reproduction even at 20 Hz. For the protection of loudspeakers, we do not recommend such operation (without the designed protective rolloff) under *any* circumstances, and such operation will void the warranty. All measurements utilized an oscilloscope with a 10 MHz bandwidth, and a true RMS meter.

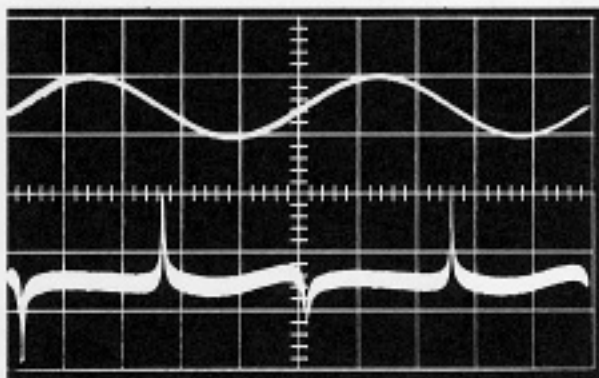

**Notch Distortion**  
Brand "X", 1 watt, 4 ohms, 1 KHz  
0.04% distortion

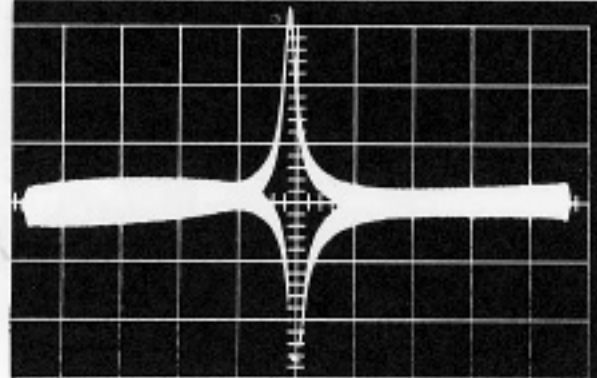

**Notch Distortion**  
Brand "X", 1 watt, 4 ohms, 1 KHz  
0.04% distortion

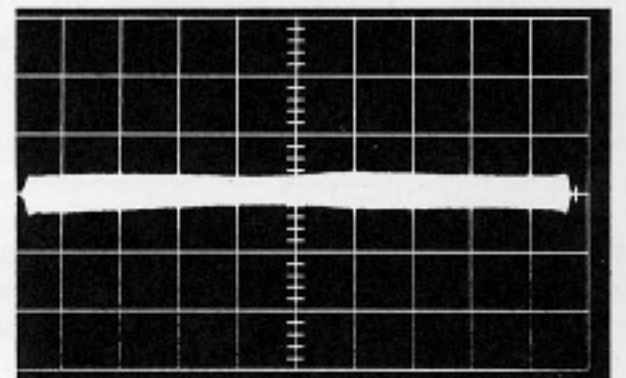

**Stereo 416**  
No notch, 1 watt, 4 ohms, 1 KHz  
0.03% distortion

### LOW POWER FREEDOM FROM DISTORTION

"Transistor sound" is often believed to originate in "cross-over notch" distortion, which is most noticeable at low levels. The first photo shows input above, and harmonic distortion analyzer output below, from another 400 watt ampli-

fier. The second and third photos show the signal as abscissa, and the analyzer distortion output as ordinate. Note that total harmonic distortion differs only by 1/100th of 1% with much notch distortion! The Stereo 416 is literally free of this fault.

## CIRCUIT DESCRIPTION

The accompanying block diagrams will aid an understanding of the specific circuit concepts expressed in the Stereo 416. Those not interested in the technology may ignore this section.

In brief, the amplifier stages are fully DC coupled, with a complementary driver, and a series connected output stage. The input is a differential pair fed from a constant current source. The full wave bridge power supply includes 10,000 mfd on both plus and minus outputs, providing filtering and dynamic load stability. Fuses on both the plus and minus supplies, volt/amp dissipation limiting, and thermal sensing cutouts provide protection for the amplifier.

The input is actively isolated from the source by a PNP-NPN follower for each channel. The input follower stages feed the switch-selected low and high filters, and then to the amplification stages.

The Dynaguard circuit continuously monitors the rectified and integrated output voltage from the amplifier. This signal is an indication of the power available to a load at the amplifier output, whether or not a load is connected. When the integrated signal exceeds the reference (permissible) level, the limiting action commences. Dynaguard limits the maximum area under the output voltage curve to the selected level within 1 dB, from its threshold to drive levels above 200 watts. Below its activation threshold it is effectively disconnected.

The DC speaker protection circuit monitors the output of both channels through a low pass filter. This signal is fed to a double ended limit detector with end limits of  $\pm 0.5$  volt DC. Excessive voltage opens the relay and disconnects the load.

To explore the circuit theory in more detail, consider the PC-29 board as three basic sections:

- 1) a) Follower (left and right)—Q1, Q2.  
b) Filters (left and right)—C6, R6, C7; C8, R7, C9.
- 2) Dynaguard circuit (left and right)
  - a) Voltage doubler and accumulator—C10, D1, D2, C11; C12, R9, R10; P1.
  - b) Logic—D3, D4.
  - c) Function—IC1, D5, D6.
  - d) Light control—D7, D13, D14, Q4, R21, R22.
- 3) Relay Circuit
  - a) Low pass filter—C18, R28, C19, R29, C20.
  - b) Double-ended limit detector—IC2, IC3, D8, D9, D10, D11.
  - c) Switch—Q5, Q6.

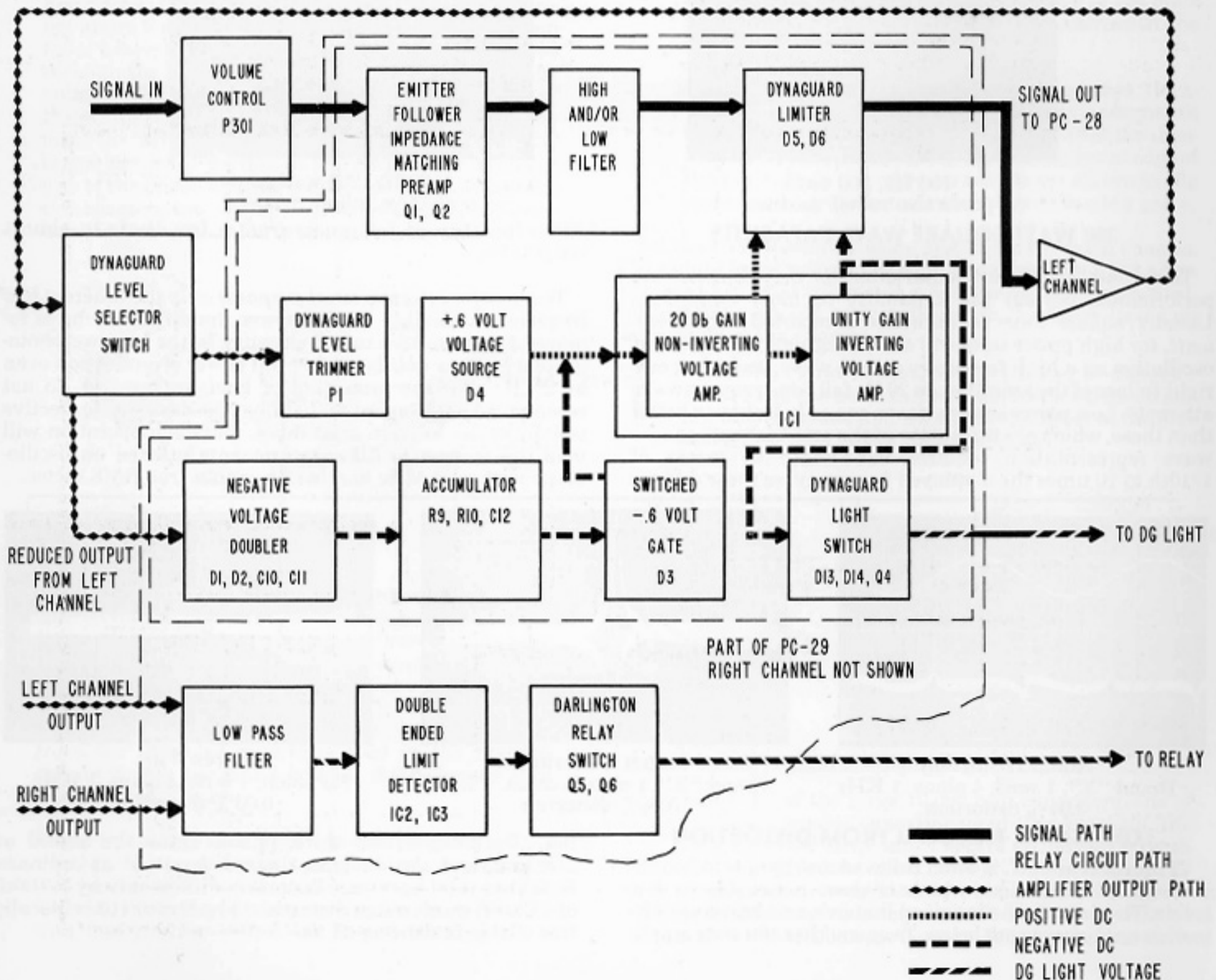



## Follower / Filters

This may be described as a voltage follower with approximately unity gain, since the voltage at Q1E is always slightly more positive than the voltage at its base. The driven transistor in the Darlington pair, Q2, provides high current amplification with very low output impedance.

Basic 6 dB/octave single section filters are enhanced to an actual 8 dB/octave characteristic by C6 and the preceding impedance forming an additional low-pass section of the high filter, and C9 and its following impedance forming an additional high-pass section of the low filter.

## Dynaguard Circuit

The amplifier's output voltage is proportioned by the setting of the front panel switch and level trimpot P1. It is clamped by C10 and D1, and rectified at peak negative value by D2 and C11. The rectified voltage is then stored in the accumulator C12, R9, R10 which is designed to bleed off the charge at the prescribed rate.

D4 is a +0.7 volt reference voltage source. D3 will start conducting when the voltage at its cathode becomes more negative than -0.7 volts, and any increase there will also appear at the anode of D4, shutting it off as a positive voltage source.

Two operational amplifiers in IC1 serve as a 20 dB voltage amplifier and inverter. When D4 conducts, the amplifier feeds about 5.5 volts to the cathode of D5, which is then inverted with unity gain for the anode of D6. Thus, when D4 is conducting, D5 and D6 are heavily reverse biased and do not affect the signal.

However, when high amplifier output voltage causes D3 to conduct, the voltage input to IC1 will start dropping to zero, and the voltages on D5 and D6 will decrease. The amplifier output will exhibit Dynaguard action when the D5 and D6 voltage becomes low enough to cause the input signal voltage to start limiting. The lowered output will in turn decrease the signal to IC1, and thus keep the limited voltage constant.

The positive-going signal from the anode of D6 provides an on gate voltage for Q4, turning on the Dynaguard signal lamp.

To adjust the Dynaguard threshold level, first switch off Dynaguard, and drive the amplifier to 40 volts out (across 8 ohms, though a load is not required) at a mid-frequency (nominally 1 KHz). Switch to the Dynaguard 120 position and adjust P1 for 31 volts out.

## Relay Circuit

A three-section low pass filter prevents signals above 10 Hz from shutting off the relay. The circuit provides DC continuity to IC2 and IC3, making the relay most responsive to any DC voltages appearing at the amplifier output.

The reference input voltages for the positive and negative limit detectors IC2 and IC3 are set by the ratios of R30 and R31; and R34 and R35. The reference output voltages are set by the voltage divider R46 and R47 in conjunction with diodes D8 and D10. D9 and D11 prevent feedthrough between IC2 and IC3 when either is operating.

Q5 and Q6 are a PNP-PNP Darlington pair used as a switch in series with the relay coil, activated by the output of the double-ended limit detector.

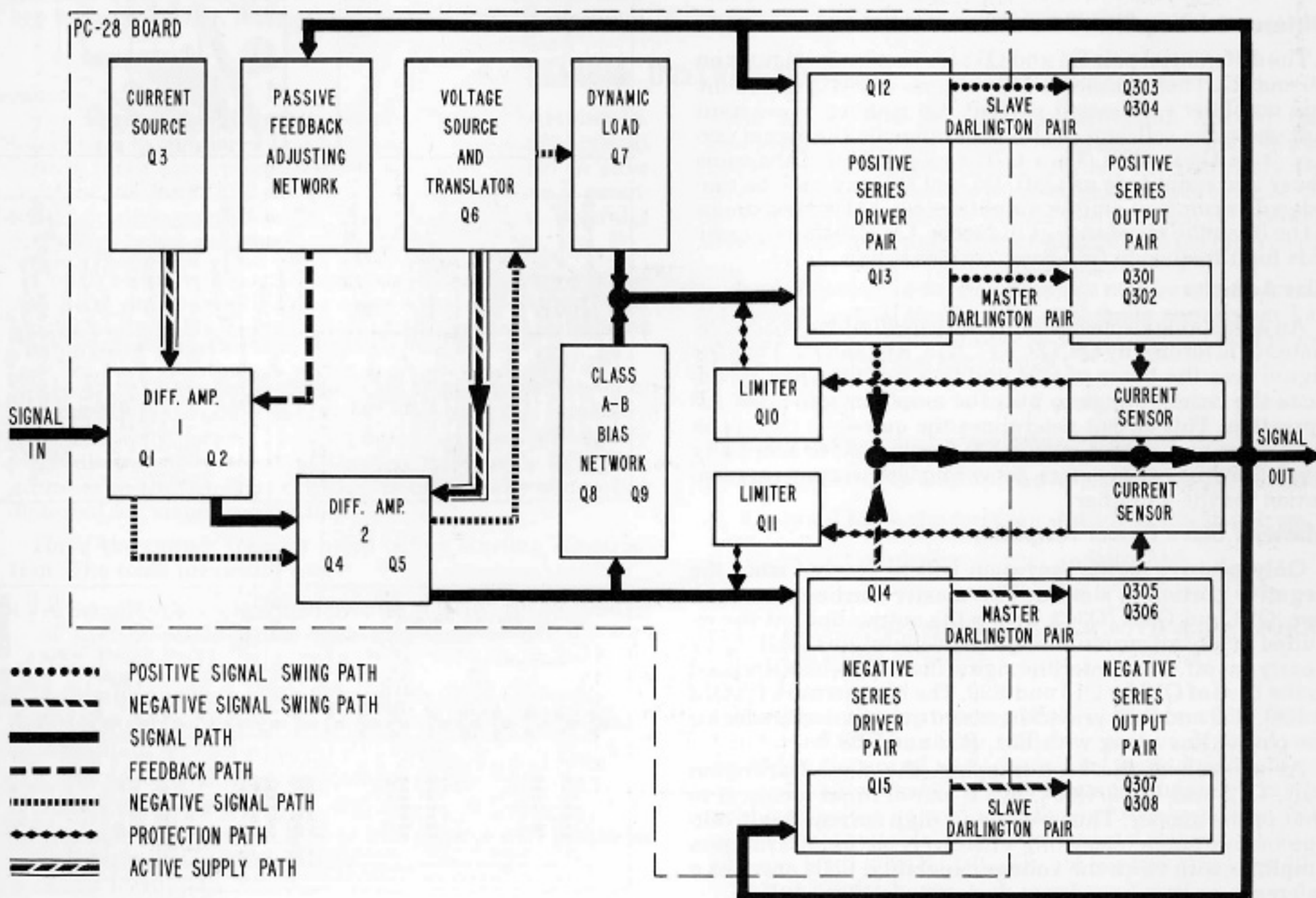

## Driver and Output Stages

Consider the PC-28 circuit board and output stage as five basic sections:

- 1) Differential amplifier #1—Q1, Q2, Q3.
- 2) Differential amplifier #2—Q4, Q5, Q6, Q7.
- 3) Bias Adjuster—Q8, Q9.
- 4) a) Master power amplifier—Q13, Q301, Q302  
(+ signals).  
—Q14, Q305, Q306  
(- signals).
- b) Slave power amplifier—Q12, Q303, Q304  
(+ signals).  
—Q15, Q307, Q308  
(- signals).
- 5) Protection circuitry—Q10, Q11, D8, D9, R301, R302, D301, D302.

### Differential Amplifier #1

Q1 and Q2 are driven from a constant-current source, Q3. D5 and R5 set the current level through Q3. Q1 and Q2 drive similar loads, ensuring approximately equal signals of opposing phase at the collectors of Q1 and Q2. D1 and D2 limit excessive out of phase signals.

The feedback network consists of R9, R10, R11, R12, C6 and C7. Since the negative feedback to the base of Q2 approximates the signal feeding the base of Q1 when the signal is DC, unity DC gain is ensured. As a result the DC level at the output varies with the DC input to Q1, determined by P1. D1 and D2 maintain a constant voltage across P1, while C2 and C3 are diode noise filters.

### Differential Amplifier #2

The differential pair Q4 and Q5 is driven by the signals on R6 and R7. Their quiescent DC voltages and R15 determine this amplifier's quiescent current. Q6 supplies a constant voltage to the collector of Q4, and transmits the signal current from Q4 to Q7B. Thus Q7B sees a signal of the same phase and amplitude as Q5B. Q5 and Q7 may each be considered as common-emitter amplifiers whose load resistance is the dynamic resistance of the other. C8, C10 and C11 provide high frequency feed-back/compensation.

### Bias Adjuster

An adjustable electronic zener with negligible dynamic resistance is formed by Q8, Q9, R17, R18, R19 and P2. Thus the signal sees the bases of Q14 and Q13 tied together. P2 adjusts the zener voltage to bias the amplifier into class AB operation. This circuit determines the quiescent current in the driver and output stages. Q8 is mounted to thermally track the driver transistors, providing temperature compensation for the amplifier.

### Master / Slave Power Amplifier

Only positive signal operation will be covered since the negative portion is similar. The master Darlington amplifier, Q13 and Q301/Q302, drives the output line. At the required quiescent current for Q13, R36 maintains Q301/Q302 nearly cut off. The centerline signal (hole #7) is bootstrapped to the base of Q12 by C13 and R29. The bias network for Q12 is R28, R29 and R30, providing a zero quiescent reference for the output line along with R31, R32 and R33.

As a result of the bootstrapping, the slave Darlington pair, Q12 and Q303/Q304, has a signal input identical to that of the master. Thus we have a high current, high voltage output stage, operating effectively as one Darlington amplifier with twice the voltage capability. R304 provides a reference emitter impedance during no-load conditions.

## Protection Circuitry

A volt-amp limiter circuit provides identical protection for both positive and negative sides of the amplifier. Again referring only to positive signal operation, when the current through R301 exceeds a preset limit, the resulting voltage turns on Q10, limiting the drive to Q13 until the current is reduced. Voltage protection is obtained from R23, R25 and D9. Any reverse voltage caused by an inductive load will be limited to 0.7 volts across both output devices by D301.

## LED Circuitry

The total circuit of 16 Light Emitting Diodes comprises 16 integrated circuit comparators (4 comparators are in each IC), and 20 discrete transistors. For each channel a 2 transistor circuit follows the positive peaks of the wave form, with fast attack and slow decay action. Thus an LED is fully illuminated with as little as a half-cycle of information at 20 kHz. A hysteresis "window" is employed in the comparator circuits so the LED is either on or off (there is no dim lighting between reference points to confuse accuracy), and so the LED remains on long enough for it to register to the eye.

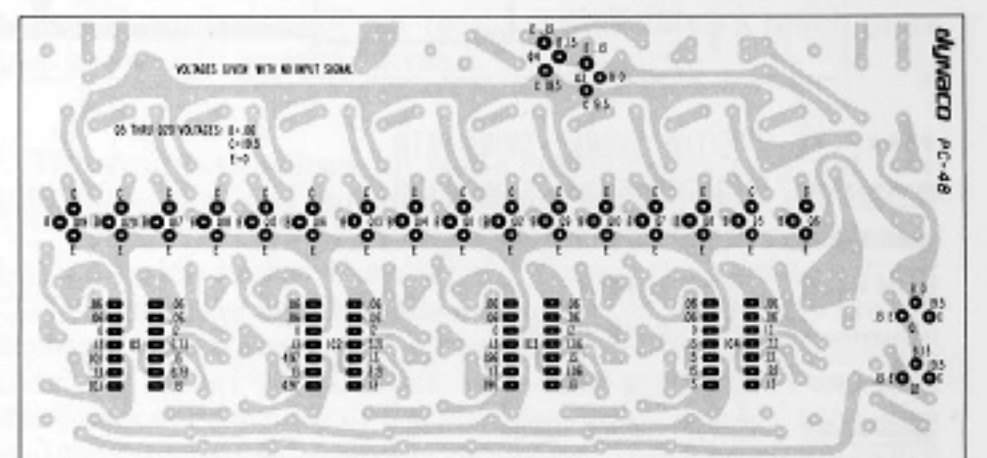
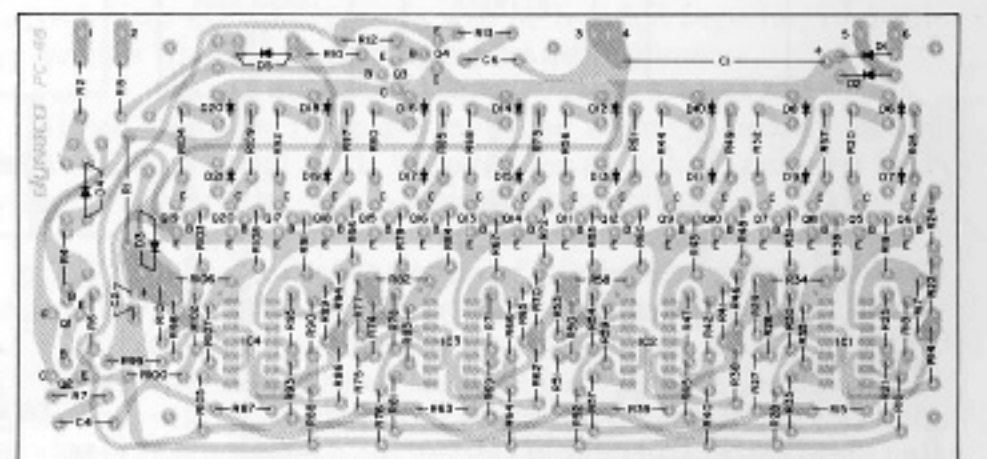
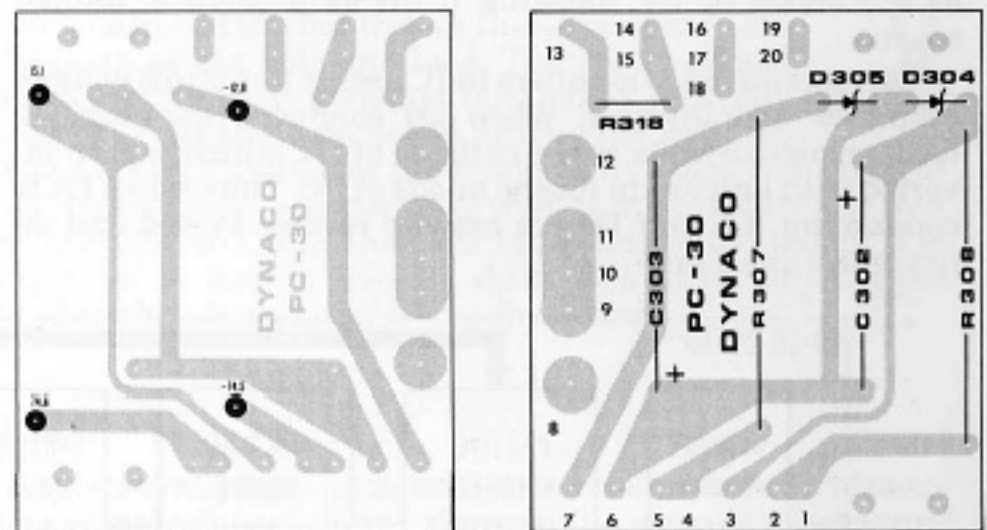

## INTERNATIONAL AC LINE VOLTAGE OPTIONS

The alternate international power transformer for the Stereo 416, part #464030, has dual tapped primary windings which are connected in parallel for 100 or 120 volts, and in series for 200, 220 or 240 volts.

The standard 15 ampere circuit breaker is supplied for 100 or 120 volt operation. An alternate 7 ampere breaker is available for 200, 220, and 240 volt operation. To provide the High-Temp lamp with proper voltage, an additional 100,000 ohms resistor is also required for the higher line voltages. It is installed between lugs #3 and #4 of terminal strip TL, in place of the wire jumper. The Stereo 416 is designed for use with either 50 or 60 Hz AC current.

These diagrams show changes in the connections of the transformer primary windings only. The secondary connections are identical to the regular instructions. Be *certain* that each connection is carefully soldered. Leads connected to PC-30 holes #8 and #12 are simply secured. They are not used. When leads connect to PC-30 holes #10 and #11 it is important that you *flow a substantial quantity of solder across the board between these holes* to assure an adequate path for the heavy current.

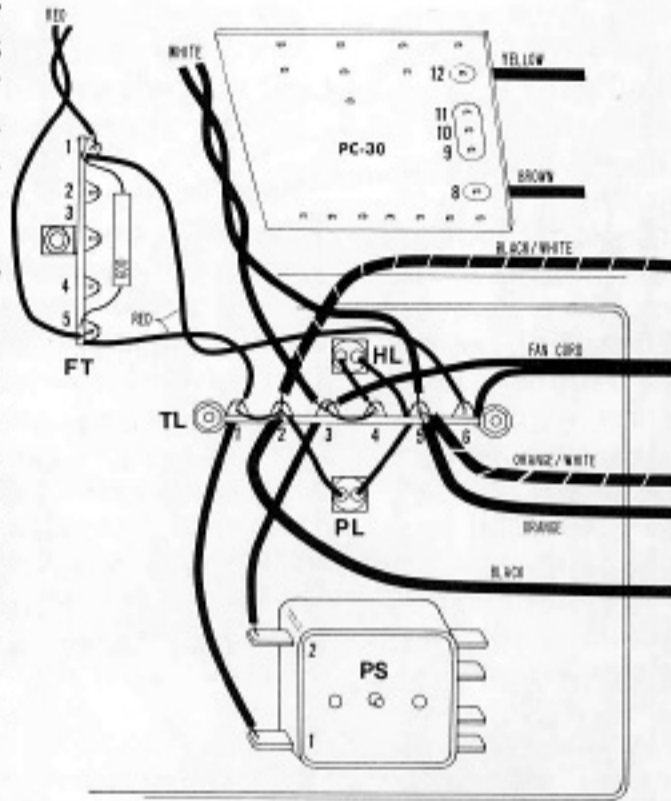

**120 VAC**

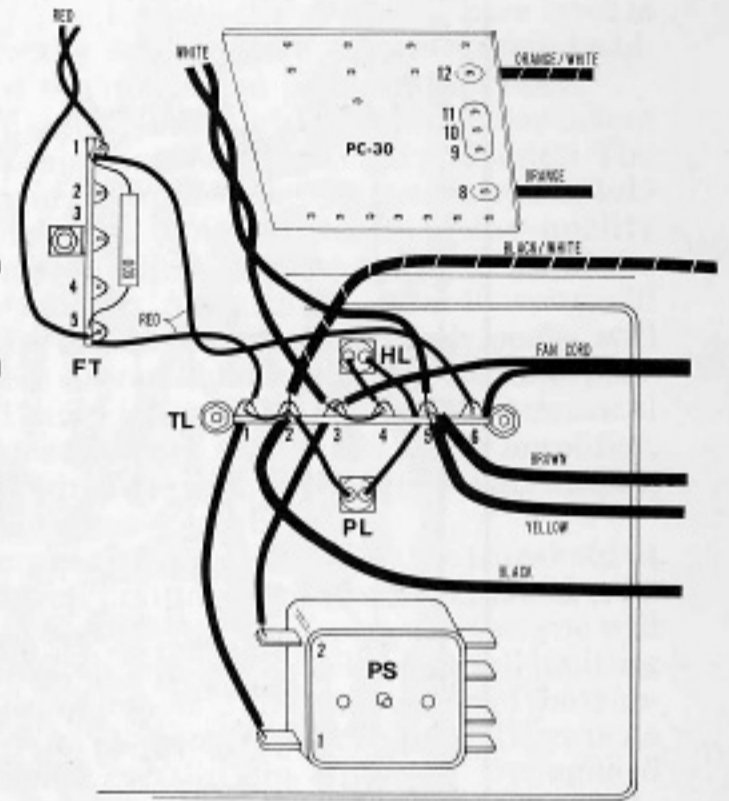

**100 VAC**

**NOTE:** Kits supplied for 200-240 VAC include a 100,000 ohm resistor (#102104), a 2,200 ohm, 10 watt resistor (#120222), and a 7 ampere circuit breaker.

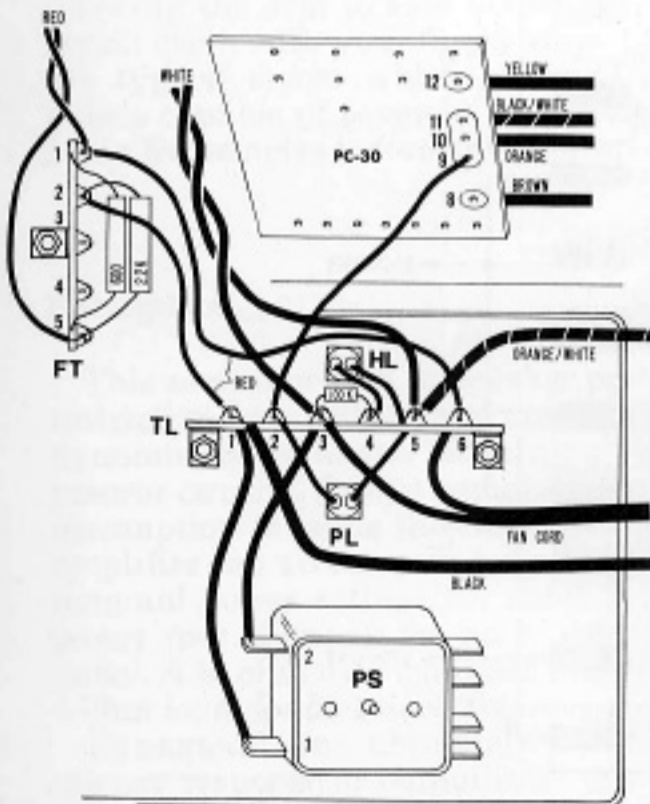

**240 VAC**

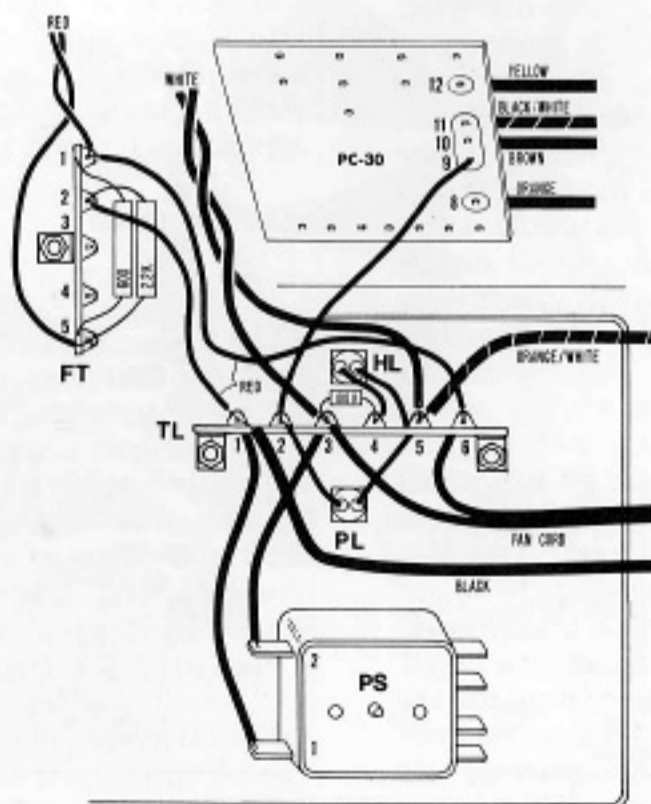

**220 VAC**

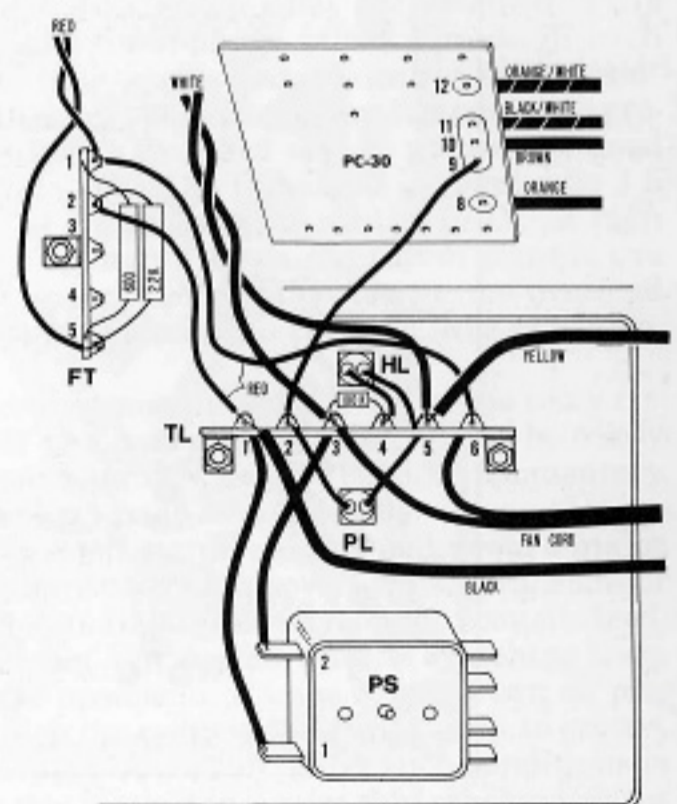

**200 VAC**

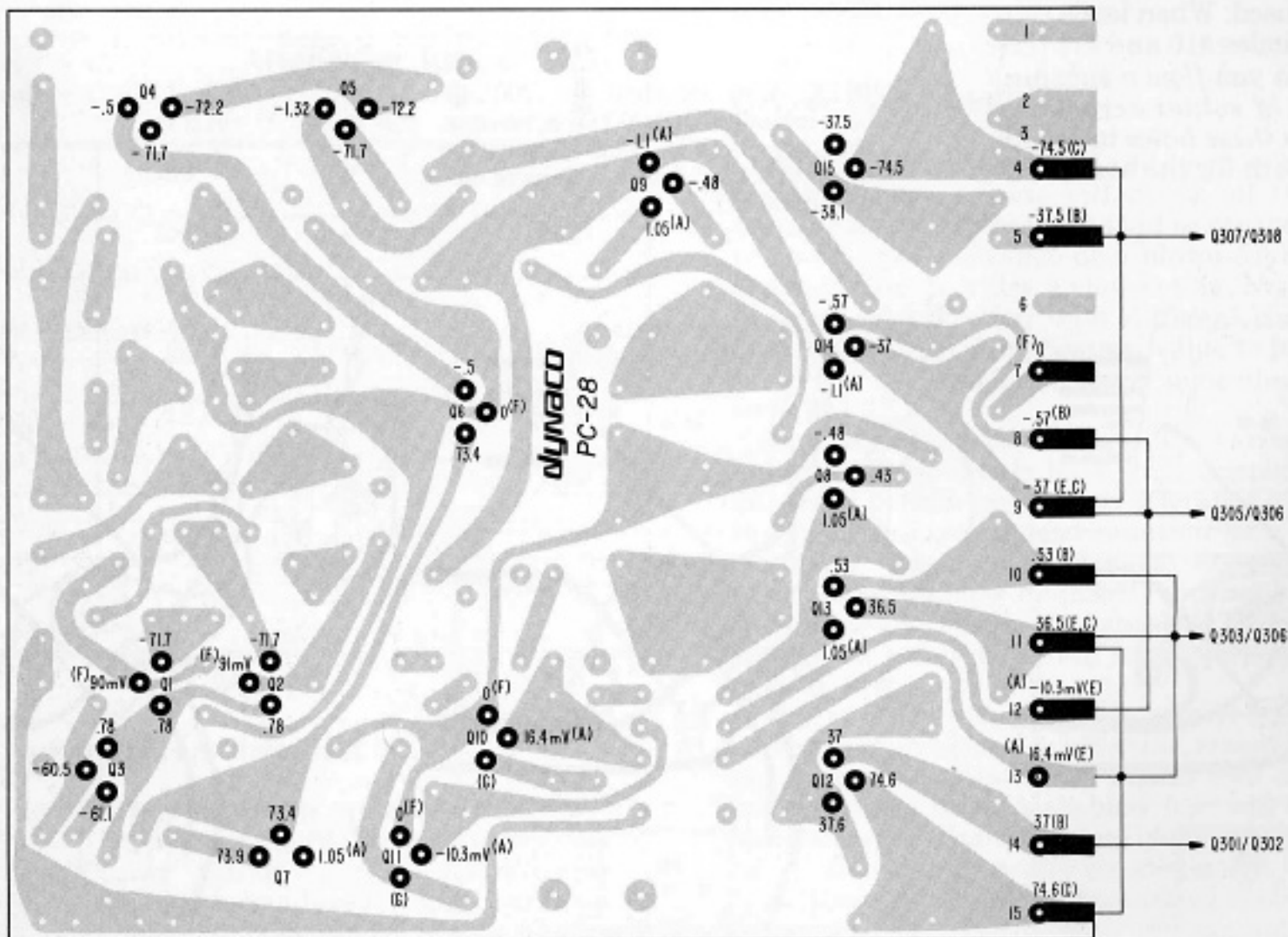
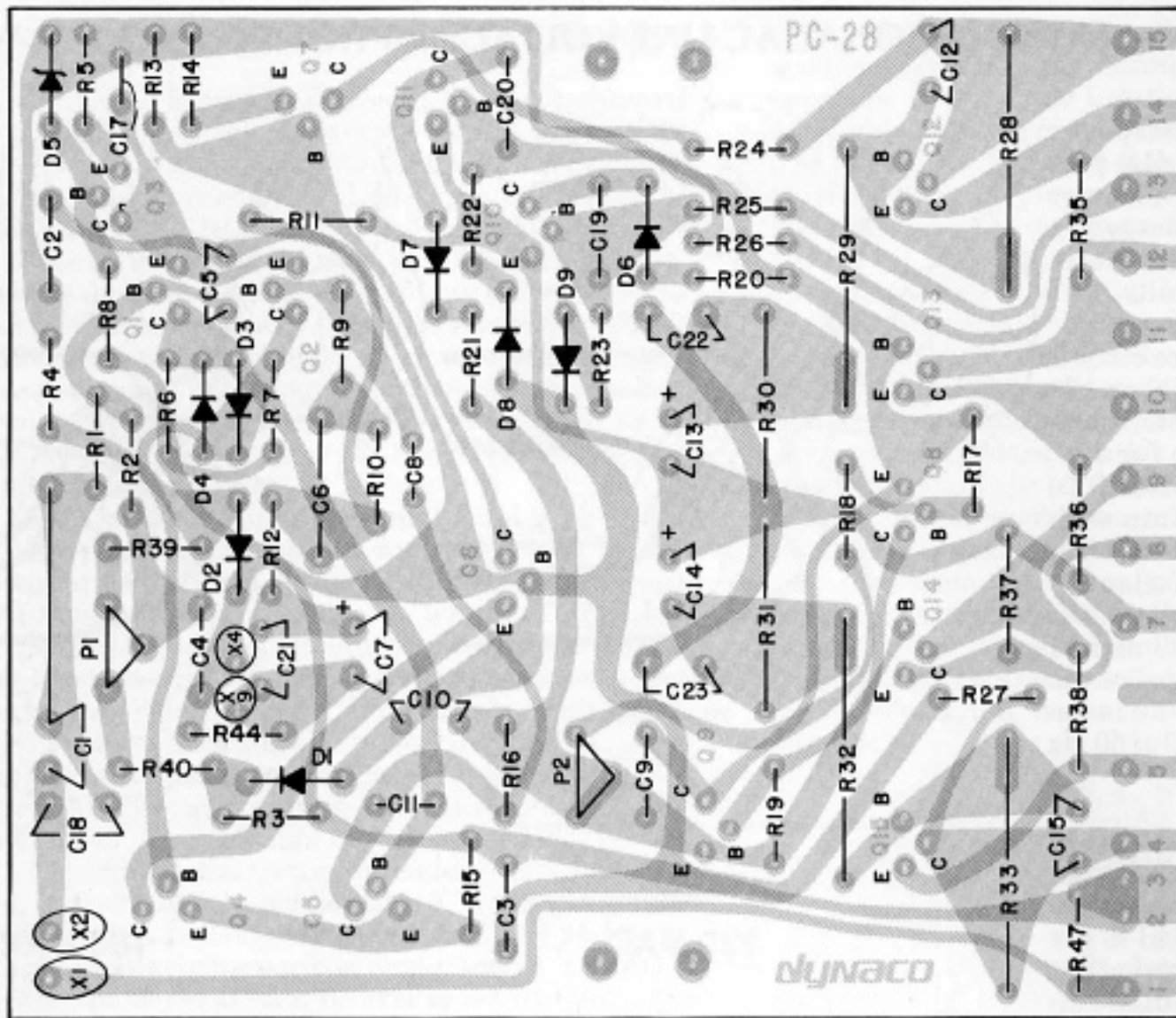

### VOLTAGE TEST POINTS

All voltages measured with a VTVM or TVM, 120 VAC line, chassis ground reference, volume controls fully counterclockwise, and Dynaguard switch "off" unless otherwise noted. 10% tolerance permissible.

**Notes:**

- A Will vary with P2.
- F Will vary with P1.

- G Do not measure. Reading valid only when amplifier is limiting.

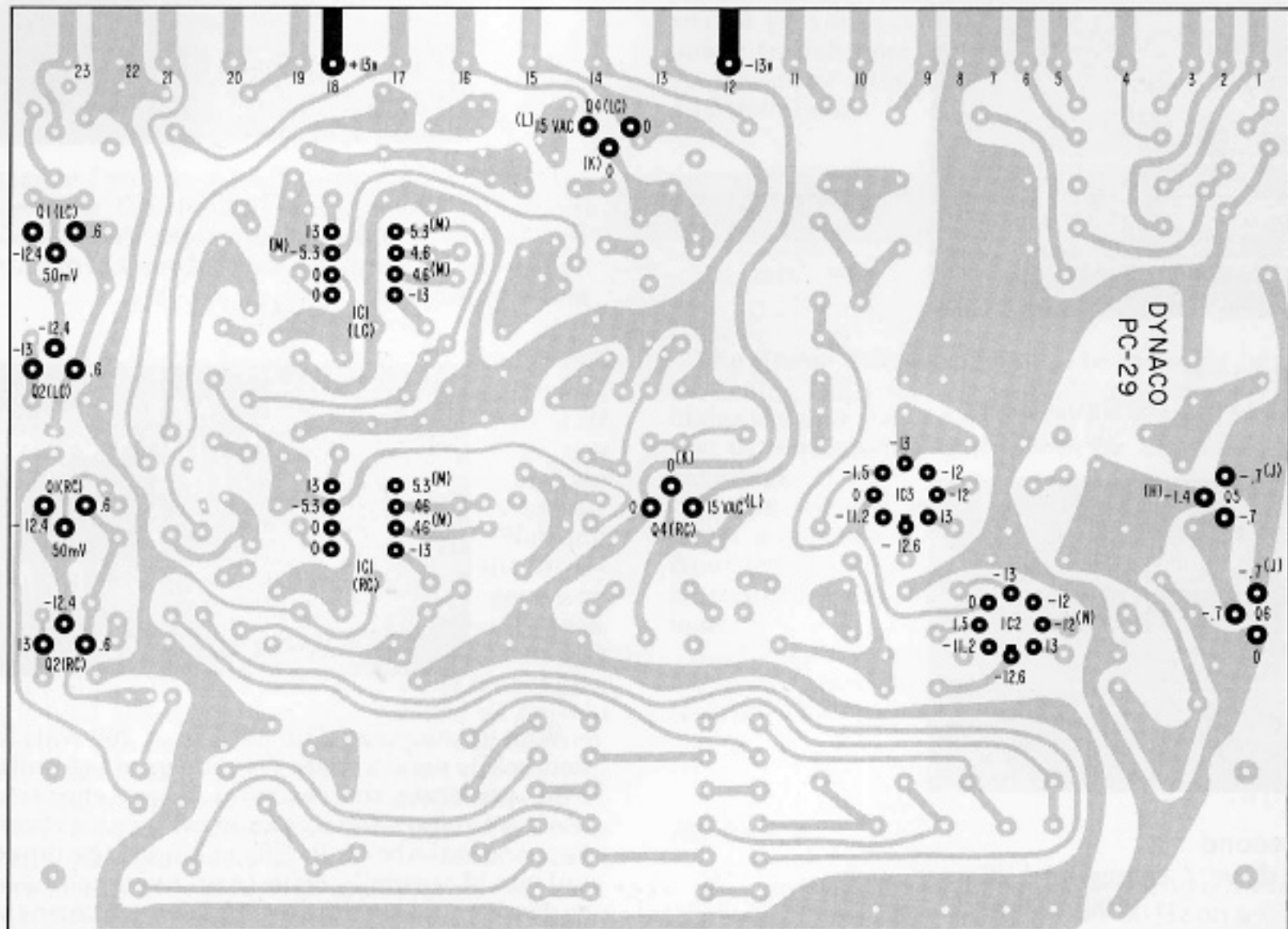
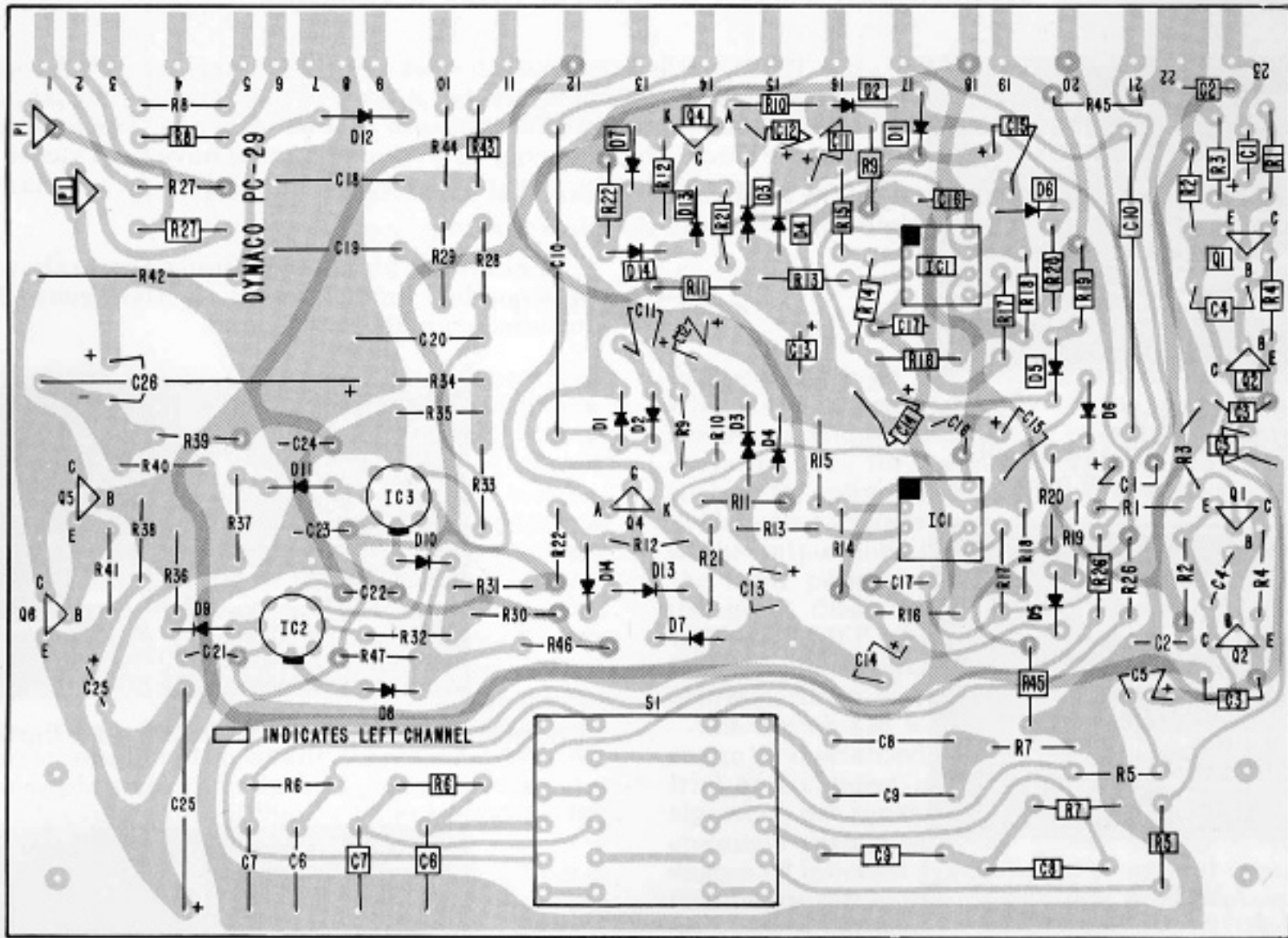

- H Becomes positive when relay shuts off.
- J Becomes -74 volts when relay shuts off.
- K Will rise to 0.7 volts when Dynaguard is on.

- L Will rise to -6 v. (or 8 vAC) when Dynaguard lamp is on.
- M Will drop close to 0 when Dynaguard is on.
- N IC2 or IC3 will rise to 7 volts when relay shuts off.

## DYNAGUARD ATTACK AND DELAY CHARACTERISTICS

These oscilloscope photographs graphically show the ability of Dynaguard to permit lesser level overdrive signals to pass for substantial periods, while restricting very powerful passages to brief intervals. The input signal is the upper trace. The frequency and traversing rate have been varied to show the signal more clearly, but corresponding time intervals are marked on each display.

The multiple photograph (input above) shows the family of smoothly limited traces as Dynaguard-20 action is initiated on a 200 watt signal.

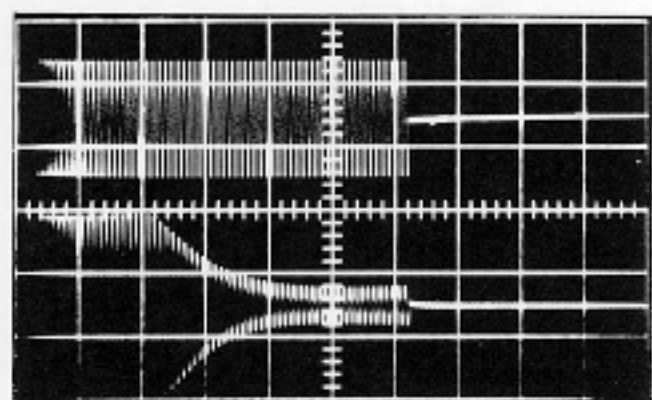

1 second  
200 watt drive / Dynaguard-20  
100 Hz 100 ms/cm

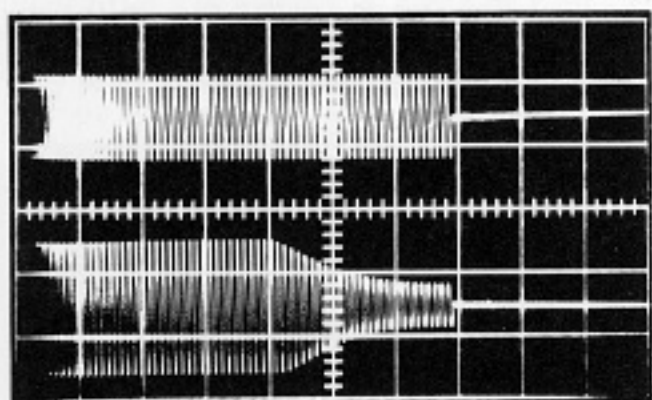

1 second  
100 watt drive / Dynaguard-20  
90 Hz 100 ms/cm

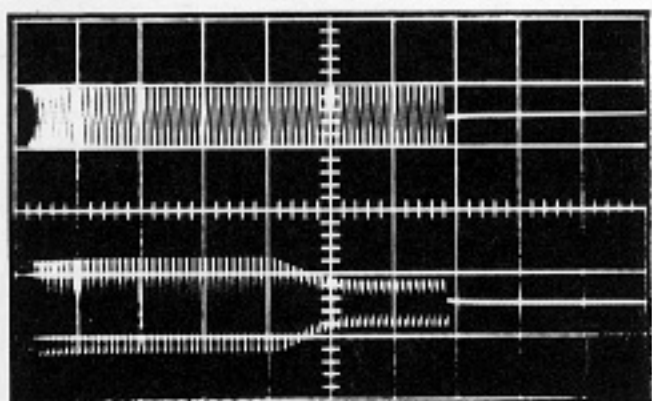

1 second  
50 watt drive / Dynaguard-20  
40 Hz 200 ms/cm

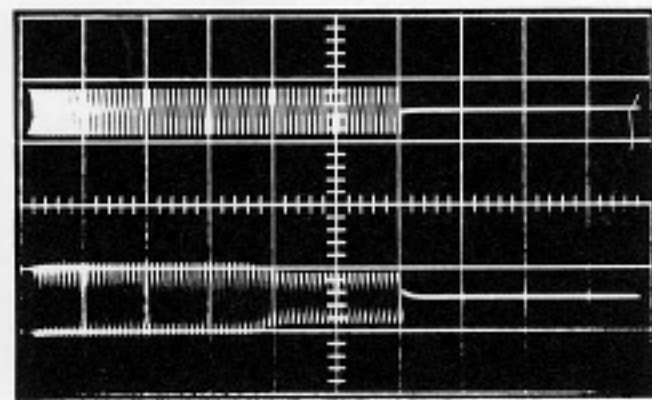

1 second  
30 watt drive / Dynaguard-20  
20 Hz 500 ms/cm

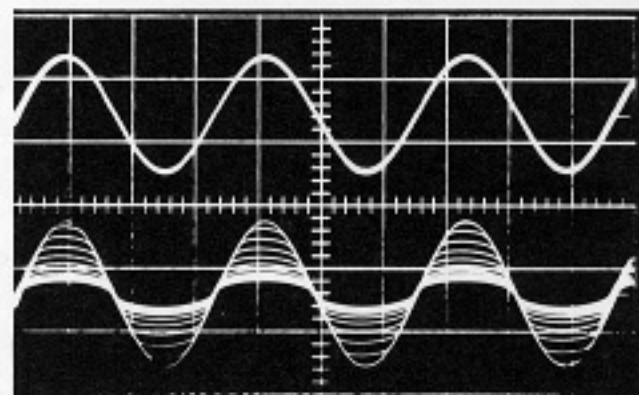

Onset of Dynaguard-20 on 200 watt signal 150 Hz

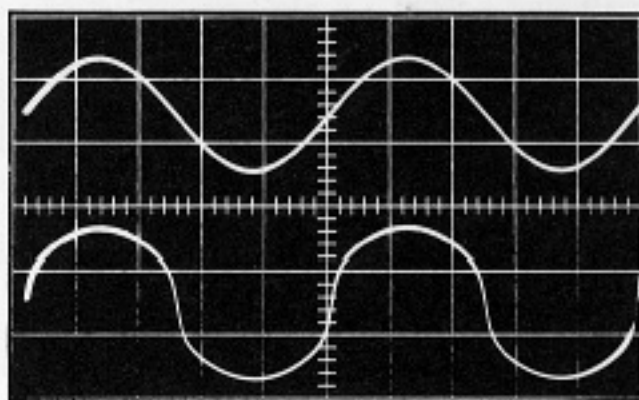

The rounded, rather than a squared or jagged, characteristic of this severely limited 200 watt signal in the Dynaguard-20 position maintains the best possible audio quality by minimizing extraneous harmonics. Input signal is upper trace.

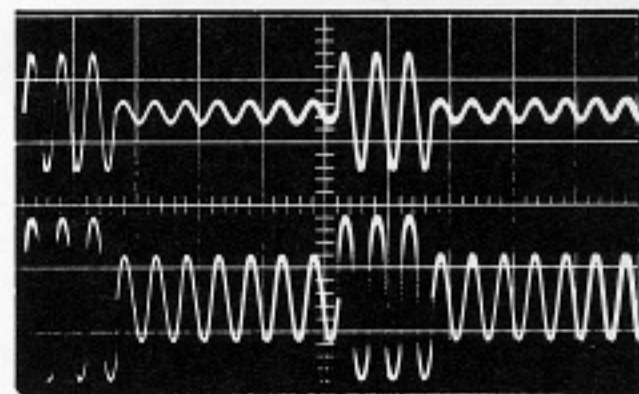

With Dynaguard-20 locked in, a 200 watt signal is limited, while an alternate 7 watt signal is totally unaffected. This preserves the essential signal characteristics, and does not reduce the dynamic range as a compressor does. Input signal above. In this example, the (upper) input signal would normally drive to an average rms output of 68.5 watts. Dynaguard limits it to an average rms output of 13.8 watts. An equivalent input for 200 watts average would yield a 20 watt Dynaguard average level.

## SERVICE POLICY AND LIMITED WARRANTY

The Stereo 416 has been carefully engineered to provide many years of musical enjoyment without difficulty. Each factory-assembled Stereo 416 has been subjected to a full complement of performance tests prior to shipment. Each assembled printed circuit board in the kit has been tested and adjusted in operation as a fully functioning unit to verify its performance capability. Nevertheless, through damage in transit, faulty kit assembly, or human error, service may sometimes be required.

To provide rapid and reliable service, Dynaco has authorized competent, well-equipped service facilities in several localities in the United States and Canada, in addition to its service facility at the factory. These stations are authorized to make repairs in and out of warranty under the terms listed below. Service is always available at the factory, but you will often find a more convenient facility locally. A current list of these facilities is enclosed. Write to Dynaco for the name of the service station nearest you.

It is the owner's responsibility to *take or send the unit freight prepaid to the service facility. A dated bill of sale must be submitted.* In the event that you incorrectly diagnose which unit is faulty, please understand that you will be responsible for a check-out charge on any properly performing kit or factory-assembled unit submitted for testing.

Shipment should be made via motor freight, REA Express (CN or CP Express in Canada), or Bus Package Express. **DO NOT USE PARCEL POST FOR IT IS NOT A SAFE METHOD OF SHIPPING ELECTRONIC EQUIPMENT.** Should damage occur due to unauthorized parcel post shipment of the complete amplifier, repairs will be made at the owner's expense, as neither the factory nor the service stations has the facilities to process parcel post claims. Be sure the shipment is fully insured (note Bus Express limitations).

It is *essential* that the amplifier be packed properly if it is to survive the considerable hazards of shipment. The original kit foam packaging, if intact, is suitable for shipping the completed amplifier. If you require packaging, send \$4.75 to Dynaco. Double boxing is strongly recommended if you formulate your own packaging.

Include with the returned unit the following information:

1. Your name and complete shipping address (Post Office box numbers are not suitable);
2. The serial number (from the rear of the amplifier), *together with a copy of your dated bill of sale;*
3. The symptoms, complete, but preferably brief. If the problem is intermittent, this *must* be noted.

Once service work has been performed, an additional 90 day warranty on the service work is provided.

Warranties apply to the original purchaser only; they are not transferable. They do not apply to units which have been physically or electrically abused, or to units which have been modified without prior written factory authorization. The use of non-Dynaco replacement parts may in some instances void the warranty. If you suspect a defect in a transformer, the leads must be unsoldered, not cut for its return. The warranty on the transformer is void if the leads have been cut too short for re-use.

Dynaco maintains a Technical Services Department to help you locate the source of, and possibly correct a problem yourself. When writing, mention the serial number of the Stereo 416 and any tests you have performed.

### Warranty for Kit-Built Units

The components in a Stereo 416 kit are warranted for a full year from the purchase date. If a defective component is found in a completed circuit board module, or kit, simply return that individual part to the *factory* prepaid, and it will be replaced at no charge. Local service stations are not obligated to supply separate parts.

If you cannot locate the source of the difficulty, ship the amplifier to the nearest authorized service station or to the factory for service. A dated bill of sale must be submitted. In-warranty parts will be replaced at no charge, although a service fee will be charged for the labor to diagnose, correct, and test the unit to ensure that it meets factory specifications. Shipping charges to and from the service facility are the owner's responsibility. Units will be returned on a COD basis via motor freight wherever possible.

If the problem in the amplifier does *not* involve mechanical or electrical hum, or the possibility of poor soldering, you may—at your option—disconnect the power transformer and return the rest of the amplifier *to the factory only* for service. It will then be within United Parcel Service (UPS) weight limits. Since the responsibility for proper diagnosis and reinstallation is yours alone, we *strongly* recommend that you contact Dynaco's Service Department prior to such action, to be certain it is the best alternative.

The warranty is void if the kit has not been completely assembled, or if other than rosin core solder has been used. Units assembled with acid core solder or paste flux will be returned unserviced.

### Warranty for Factory Assembled Units

The Stereo 416 is warranted for a full year from the purchase date, including parts and labor, and shipment costs *from* the service facility to the owner (within the U.S. or Canada). The owner is responsible for shipment *to* the service facility, and must submit a copy of the dated bill of sale.

### Service Beyond the Warranty Period

Dynaco establishes maximum labor fees which may be charged by its service facilities (plus the cost of parts, and shipping charges) without prior approval by the owner. A current list of authorized service stations and the current established fee for any unit will be supplied by Dynaco on request. Dynaco cannot assume responsibility for service at other than *Dynaco authorized service stations.*

Dynaco reserves the right to limit the service facility or the established fees to two years from the date of purchase. Dynaco assumes no liability or responsibility for injury or damages sustained in the assembly or operation of this equipment, or for damages to other equipment connected to it. Dynaco reserves the right to make design changes without the obligation to revise prior versions. Prices and specifications subject to change without notice.

## PARTS LIST

Parts of a similar type which do not change performance will sometimes be included as a matter of expediency. This will account for slight variations in value and appearance. To avoid a shortage, extra hardware may be included for some sizes.

1	Access plug, round plastic	PART #	895008		2	Socket, lamp	PART #	386001
2	Binding post, black (2 parts)		371876		1	Socket, 4-input, heavy duty		354000
2	Binding post, red (2 parts)		371877		16	Socket, transistor		353001
4	Bolt, 1/4" diameter		611602		1	Socket strip, dual input		355012
1	Brace, vertical chassis		711102		1	Switch, power, rectangular		333241
4	Bracket, L-shape, circuit board		711113		1	Switch, single push, 4PDT		331105
1	Bracket, flat, fan		717015		1	Switch, rotary, 12 lug		333020
5	Bracket, U-shape, heat sink		711111		1	Switch, rotary, 12 lug		333025
1	Bracket, Z-shape, line cord		711109		1	Terminal strip, 5 lug, "O" style lugs		375002
2	Bracket, round, capacitor		717003		1	Terminal strip, 6 lug, "O" style lugs		375010
1	Capacitor, 0.01 mfd disc (103 M)		228103		1	Terminal strip, 6 lug, "I" style lugs		375016
6	Capacitor, 0.1 mfd disc		224104		1	Terminal strip, 8 lug, "I" style lugs		375008
2	Capacitor, 500 mfd or 470 mfd		283507		1	Thermal compound, capsule, 5 cc.		945004
2	Capacitor, 10,000 mfd		284109		2	Thermal sensor, output		342001
1	Chassis		711101		1	Thermostat, fan		342007
2	Choke Coil Assembly		453001		8	Transistor, 2N6029, 2N6030		561356
2	Circuit board assembly, PC-28		957328		8	Transistor, 2N5629, 2N5630		571104
1	Circuit board assembly, PC-29		957029		1	Transformer, power		464026
1	Circuit board assembly, PC-48		957048			alternate (International)		464030
1	Circuit board, PC-30, bare		950030		8	Wire tie, plastic		894003
1	Circuit breaker, 15 ampere		342702		1	Wire, hookup, red, #20, 30 feet		
	Alternate 7 ampere (International)		342703		1	Wire, hookup, green, #20, 25 feet		
2	Clip, mounting, thermal sensor		737003		1	Wire, hookup, black, #20, 35 feet		
2	Control potentiometer, 100,000 ohms		142104		1	Wire, hookup, blue, #16, 7 feet		
1	Cover, perforated sheet metal		711110		1	Wire, hookup, yellow, #16, 10 feet		
2	Cover, transistor, plastic		826001		1	Wire, hookup, white, #16, 14 feet		
1	Diode block, rectifier		544504		1	Warranty card		
2	Diode, glass or plastic, 1N4743		540113		1	Manual, instruction		
4	Diode, plastic 1N4003		544012			<i>Hardware</i>		
1	Fan		943001		3	Grommet, rubber		895006
4	Feet, rubber		859757		1	Lockwasher, 3/8"		617165
1	Finger guard, fan		717008		5	Lug, ground		639309
1	Front panel		711104		15	Nut, #4-40 KEP with lockwasher		615244
1	Front plate, decorative aluminum		769025		42	Nut, #6-32 KEP with lockwasher		615304
2	Fuse block, dual clip		341007		4	Nut, #10-32, chrome, for binding posts		625565
2	Fuse holder, black, with cap		341077		4	Nut, #10 KEP with lockwasher		615504
2	Fuse, 1 ampere AGC/3AG, long		342024		4	Nut, 3/8"		614065
2	Fuse, 5 ampere AGC/3AG, long		342025		1	Nut, 1/2"		614876
4	Fuse, 10 ampere AGX/8AG, short		342012		12	Screw, machine, #4-40 x 1/4"		611245
2	Handle, aluminum		760001		3	Screw, machine, #4-40 x 1"		611204
1	Heat sink assembly		993112		4	Screw, machine, #4-40 x 3/4" (or 5/8") self-tapping		612201
1	Insulator for input socket strip, phenolic		801372		14	Screw, machine, #6-32 x 5/16"		611355
1	Insulator for power switch, cardboard		805003		20	Screw, machine, #6-32 x 5/16" SEMS with lockwasher		613354
16	Insulator for transistor, metal		856001		22	Screw, machine, #6-32 x 1/2"		611385
1	Insert, dark plastic, rectangular		814005		2	Screw, machine, #6-32 x 3/4" plastic		671375
4	Knob, large, aluminum		764188		5	Screw, machine, #6-32 x 3/4"		611325
1	Knob, small, aluminum		764187		4	Screw, machine, #6-32 x 1 1/2"		611305
3	Knob, push on, aluminum		814053		10	Screw, machine, #8-32 x 3/8" SEMS with lockwasher		613454
1	Label, input/output		898003		4	Screw, machine, #10-32 x 3/8" SEMS with lockwasher		613564
1	Label, serial number		898002		4	Screw, machine, #10-32 x 1/2"		611584
1	Label, C-100 accessory warning		898050		4	Screw, machine, #10-32 x 1 3/4" flat head		611501
2	Lamp, bayonet, #53		526053		16	Screw, self-tapping, #6 black		613349
2	Lamp, neon, red		521021		32	Screw, sheet metal, #6 x 3/4"		612304
1	Line cord, AC, 3-conductor		322093		5	Set screw, Allen head 3/16"		613834
1	Line cord, fan		322061		4	Spacer, tubular, short metal		660261
1	Plate, relay mounting		711107		4	Spacer, tubular, long metal, 1/4" diam.		764125
1	Relay		539248		3	Spacer, tubular, plastic		660022
8	Resistor, 0.18 ohms, 10 watts		120180		4	Spacer, tubular, metal, 1/2" diam.		660020
2	Resistor, 10 ohms, 10 watts		120100		1	Strain relief, black, plastic		895007
8	Resistor, 10 ohms, (brown-black-black)		110100		10	Terminal clip, spade		371005
2	Resistor, 82 ohms (gray-red-black)		119820		3	Washer, small flat		616354
2	Resistor, 220 ohms (red-red-brown)		119221		4	Washer, large flat		616005
2	Resistor, 300 ohms (orange-black-brown)		119301		1	Wrench, Allen 1/16"		968522
1	Resistor, 600 ohms, 10 watts		120601		1	Wrench, Allen, 1/8"		968523
2	Resistor, 850 ohms, 10 watts		120851					
2	Resistor, 1k (1000) ohms, 10 watts		120102					
4	Resistor, 10,000 ohms (brown-black-orange)		119103					
2	Resistor, 18,000 ohms (brown-gray-orange)		119183					
2	Rubber stripping, 3"		851016					