

NOTES:
 1. ALL RESISTORS
 ALL RESISTANCE
 2. ALL CAPACITDF

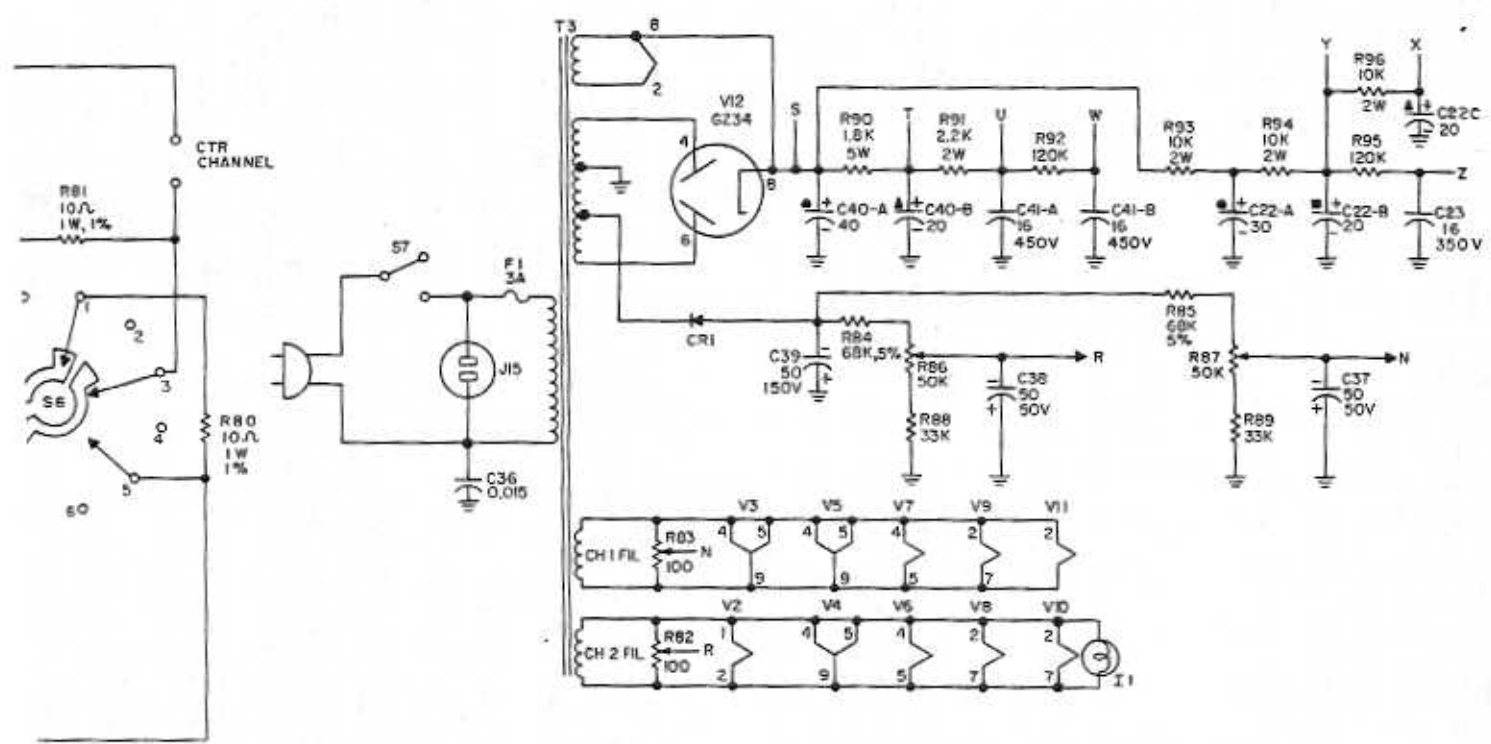
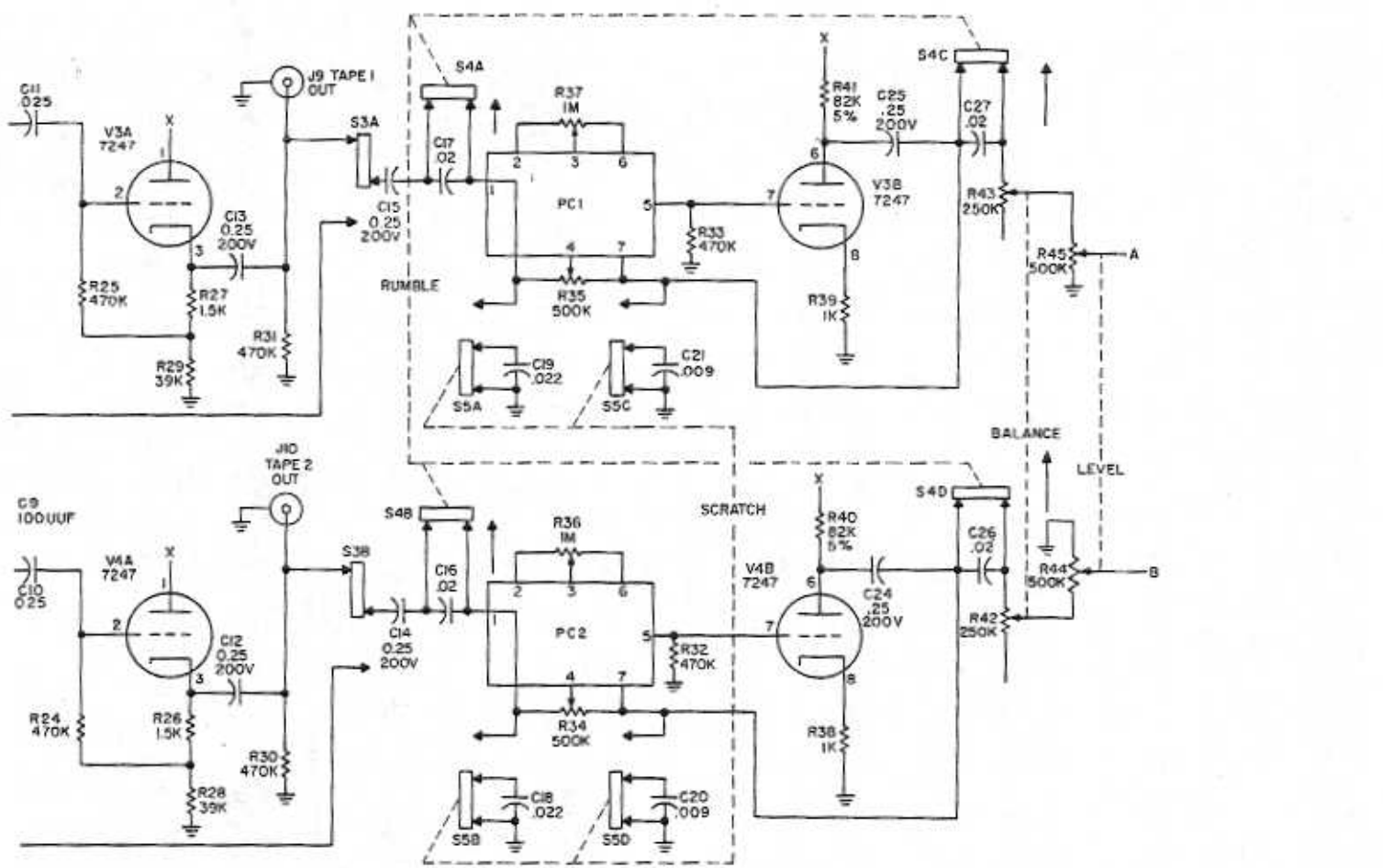

RESISTORS ARE 1/2W, 10% UNLESS OTHERWISE SPECIFIED.
 CAPACITANCE VALUES ARE IN OHMS.
 CAPACITORS ARE IN UFU UNLESS OTHERWISE SPECIFIED.

3. ROTARY SWITCHES ARE SHOWN VIEWED FROM KNOB END
 IN EXTREME COUNTER CLOCKWISE POSITIONS.
 4. UFU = MICRO-FARAD, UFU = MICRO-MICRO FARAD, K = KILOHMS
 M = MEGOHMS.

Schematic Diagram