

HIGH FIDELITY 60 WATT AMPLIFIER

MODEL

HF-60

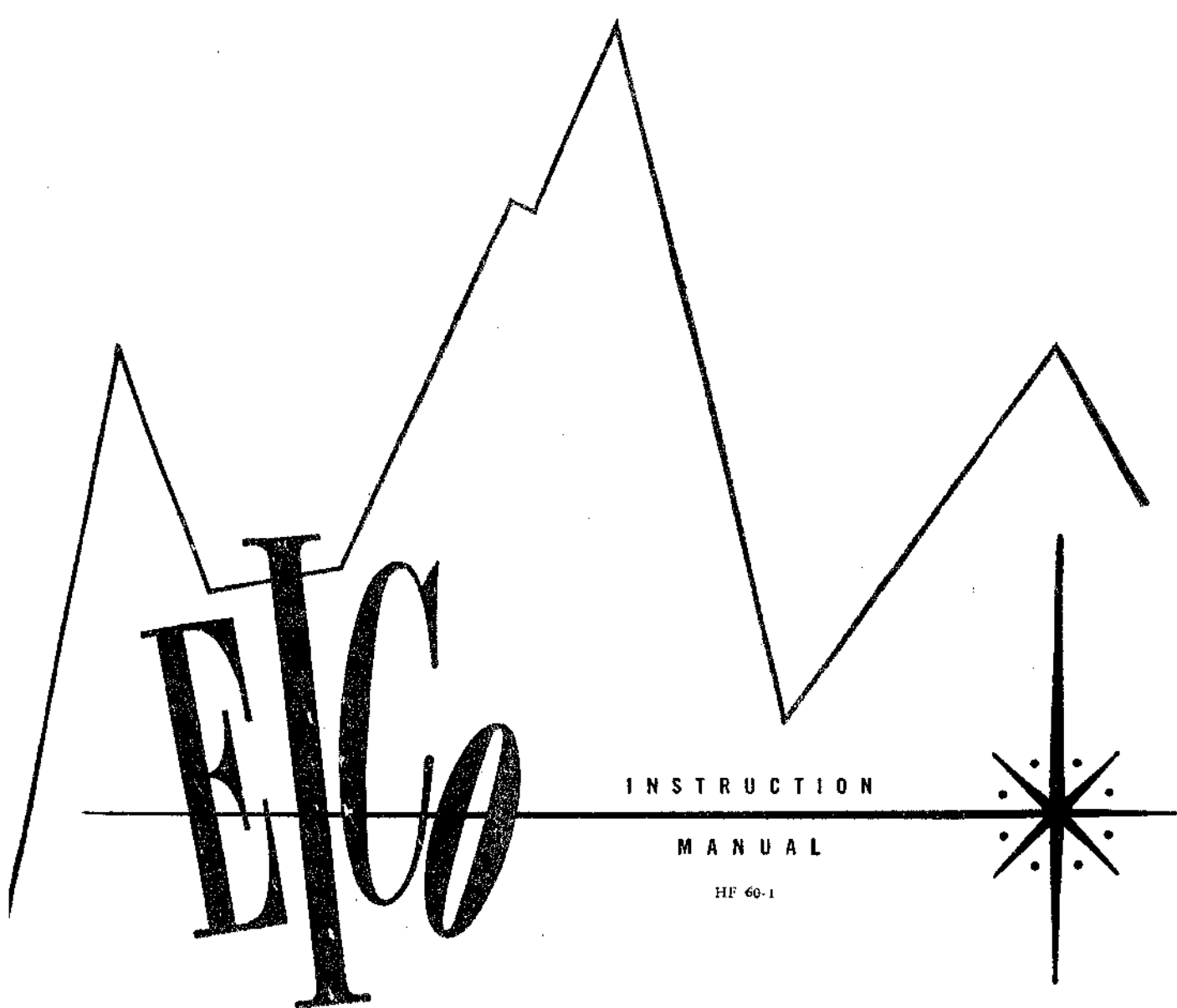

INSTRUCTION

MANUAL

HF 60-1

ELECTRONIC INSTRUMENT CO. INC.
3300 NORTHERN BLVD., L. I. CITY 1, N. Y.



MODEL HF50 & HF60 ADDENDA (Book #^{HF50}
HF60-1)

Page 6 indicates that the HF50 and HF60 can operate safely with line voltages up to 124 volts and recommends the use of a voltage adjusting device when line voltages exceed this value (paragraph #3). The power transformer now provided permits the use of this instrument on line voltages up to 132 volts without component failure being likely. If your line voltage is 121 volts or less, connect the black-red lead to the fuseholder. Tape up the exposed end of the loose black-green lead and tape this lead with friction tape to the black-red lead so that it does not hang loose in the chassis.

not If your line voltage is between 121 volts and 132 volts, connect the black-green lead to the fuseholder. Tape up the exposed end of the loose black-red lead and tape this lead with friction tape to the black-green lead so that it does not hang loose in the chassis. If you are certain as to your line voltage, or think that it may be high, connect the black-green lead to the fuseholder and tape up the black-red lead as above. For voltages exceeding 132 volts a voltage regulator or adjusting device must be used. However, line voltages exceeding 132 volts is unlikely.

When adjusting the bias and balance controls, adjust the line voltage to 117 volts if the black-red lead is connected to the fuseholder, and 125 volts if the black-green lead is connected to the fuseholder (page 5).

Please make the following changes in the construction book if you are building this unit from a kit:

- step 7* {
- (A) If your line voltage is less than 121 volts, step 7 on page 7C should read:
7. () Fig. 3. Cut the black lead from hole "Y" to 3" and connect to J5-1 (C). Cut the black-red lead to 5 1/2" and connect to XF1-1 (S). Tape the exposed end of the black-green lead to insulate this wire and tape the lead to the black-red wire so that it does not hang loose.
 - (B) If your line voltage is greater than 121 volts, step 7 on page 7C should read:
7. () Fig. 3. Cut the black lead from hole "Y" to 3" and connect to J5-1 (C). Cut the black-green lead to 5 1/2" and connect to XV1-1 (S). Tape the exposed end of the black-red lead to insulate this wire, and tape the lead to the black-green wire so that it does not hang loose.

The output transformer and the output tubes of any amplifier are subjected to severe stress when the amplifier is operated at a high signal levels without a load. To protect these components against possible damage, always have either a speaker or resistive load connected to the output terminals of the amplifier while it is being operated.

I. E. 1161 Electronic Inst. Co., Inc., Long Island City 1, N.Y.

MODEL HF 60 HIGH FIDELITY 60 WATT AMPLIFIER

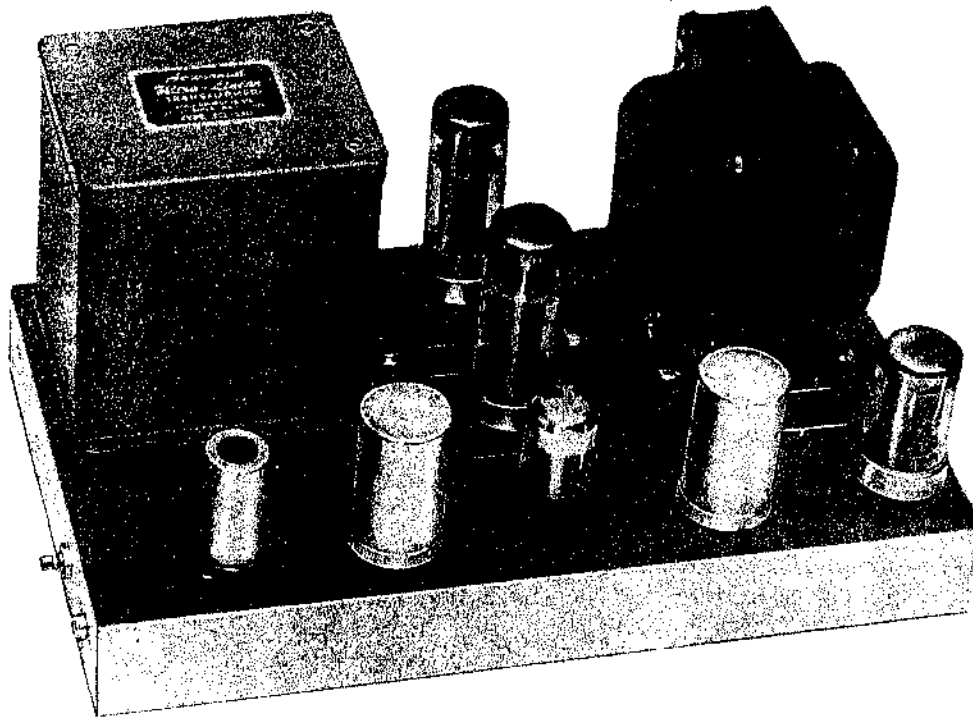

general description

GENERAL

The EICO HF-60 is a basic power amplifier designed for flawless reproduction of the entire dynamic and frequency range achieved in present-day microgroove and tape recordings. Enormous undistorted reserve power, excellent transient response, and exceptional stability result in effortless response to peak power demands, well-defined bass, clean treble, and an overall crystal clarity of the reproduced sound without false emphasis anywhere in the audio spectrum.

The circuit employed is a variant of the British Mullard type including a genuine Ultra-Linear output stage, a combination now recognized as one of the very best possible amplifier designs. A plus factor in the EICO HF-60 is the use of the ACRO TO-330 output transformer, the very finest in its power class. Other factors worth considering in the choice of an amplifier are detailed in the list of features below.

The HF-60 has been designed to maintain its excellent characteristics under speaker load as well as the resistive load normally used for testing. Phase corrections have been provided at both extremes of the audio spectrum to insure stability under all conceivable conditions and to insure that variations in components and construction will not affect the performance. Overload characteristics are excellent and the HF-60 will not exhibit bounce or flutter under pulsed conditions.

The Model HF-60 can be operated from any source capable of delivering a 1/2 volt input signal. The source may be any preamplifier-control unit or a combined tuner-preamplifier-control unit. An excellent preamplifier-control unit, designed to take its operating power from the HF-60, is the EICO Model HF-61A High Fidelity Master Control. The Model HF-61 is identical to the HF-61A except that it contains its own power supply.

FEATURES

1. EF86 phenomenally low-noise, high gain, voltage preamplifier.
2. Direct coupling between voltage preamplifier and phase inverter to eliminate a time constant.
3. 6SN7GTB cathode-coupled ("long-tailed") phase inverter for forced balance over the entire frequency and dynamic range. Provides drive for the output stage from equal and comparatively low impedances.
4. EL34/6CA7 output pentodes in a push-pull Ultra-Linear output stage operating with fixed bias.
5. Fully potted ACRO TO-330 Output Transformer—the "heart" of the amplifier—provides a level of performance previously thought unattainable at a competitive price. It is manufactured from the finest and costliest materials on special winding equipment, using unique, patented design methods. Each transformer is extensively tested and a-c balance is guaranteed to 1%.
6. Heavy duty power transformer with reserve capacity

for powering any preamplifier.

7. Extra-rugged GZ34 rectifier tube with indirectly heated cathode to eliminate high starting voltage on the electrolytic filter capacitors and to delay the application of the full B+ voltage to the amplifier tubes until they have warmed up.
8. Input level control.
9. Fuse and panel mount fuse holder.
10. Control of bias voltage for output tubes.
11. DC Balance adjustment of output tubes; convenient metering terminals provided.
12. Standard octal socket provided for preamplifier power take-off and remote on-off switching.
13. Switched and unswitched AC convenience outlets.
14. Heavy gauge steel chassis.

SPECIFICATIONS

Rated Output Power: 60 watts continuous; 130 watts peak.

IM Distortion (60 & 6000 cps at 4:1): Below 1% at 60 watts; below 0.5% at 50 watts.

Total Harmonic Distortion: Below 0.5% at any frequency from 20 cps to 20 kc within 1 db of 60 watts.

Undistorted Sinusoidal Frequency Response: ± 0.5 db 5 cps to 100 kc at 1 watt level; ± 0.1 db 15 cps to 35 kc at any level from 1 milliwatt to 60 watts; no peaking or raggedness outside audio range.

Square Wave Response: 20 cps to 25 kc essentially undistorted; 3 micro-seconds rise time; no overshoot at any frequency or power level nor visible rounding below 15 kc.

Inverse Feedback: 21 db

Stability Margin: 16 db

Damping Factor: Above 12, 20 cps to 20 kc; 17 at 1 kc.

Sensitivity: 0.52 volt for 60 watts out.

Hum: 90 db below rated output

Speaker Connections: 4, 8, and 16 ohms

Tubes: 2- EL34/6CA7, 1- EF86/Z729, 1- 6SN7GTB, 1- GZ34

Power Source: 110-120 volts, 60 cycles; 150 va at no signal, 200 va at signal developing rated power, 250 va at signal developing peak power (overload); 3 amp fuse.

Size: HWD - 7" X 14" X 8"

Weight: 30 lbs.

mechanical installation

GENERAL

a) **HEAT DISSIPATION (VENTILATION):** In common with other electronic equipment, the Model HF-60 produces a great deal of heat in normal operation. Unless continuous and adequate air flow is obtained around the heat producing elements, these elements will overheat and their useful life will be greatly curtailed. Adequate ventilation will be provided if the amplifier is installed in an open-back console provided that the top of the amplifier is spaced at least two inches below any shelf mounted above it. If the cabinet is enclosed at the rear, provide several large holes or slots as low down and as high up in the cabinet back as possible. As an alternate, holes may be provided in the sides, bottom, or top of the cabinet. The important thing to remember is that effective ventilation requires provision for cool air to enter at the bottom and to leave at the top.

If the amplifier is not installed in a console, it should be situated preferably on an open surface. An attractively finished matching cover for the Model HF-60 is available which will provide a "finished" appearance as well as protection when the amplifier is not installed in a console. Four rubber feet are also provided so that the amplifier will not mar the surface of furniture on which it is placed.

b) **ACCESSIBILITY TO PARTS:** Tubes are the most frequently replaced items in electronic equipment. If the amplifier is placed in a console, sufficient space should be allotted to reach and remove any tube in the amplifier. Furthermore, input and output terminals of the amplifier should be accessible to permit easy interchanging of system components for comparison. If antennas are strung around the back of the console in which the amplifier is installed, arrange them so they will not interfere.

c) **ELECTRICAL ISOLATION:** To realize the full benefit of having a power amplifier physically separate from the preamplifier-control unit and/or tuner, the power amplifier should be placed at least one foot away (more if possible) from either or both of these units.

d) **ACOUSTICAL ISOLATION:** If amplifier and speaker are installed in the same cabinet, provide sufficient separation to minimize mechanical speaker vibration reaching the amplifier. The minimum separation is about one foot.

CONSOLE MOUNTING

Having determined a proper location for the amplifier in the particular console, the correct procedure for mounting the amplifier chassis is as follows: a) If the rubber feet have been inserted in the bottom plate, remove them (pry out with a thin screwdriver). b) Remove the 10 screws which fasten the bottom plate to the chassis. c) Place the bottom plate (bumps facing up) at the location on the shelf or other mounting surface in which it is desired to mount the amplifier. With a sharp pencil, placed with its point directly against the edge of the lower surface of the bottom plate, draw the outline of the bottom plate on the shelf and also mark the positions of the two extreme holes on both the long sides (front & rear). d) Remove the bottom plate and drill each of the marked holes on the shelf to a diameter of 1/4". e) Refasten the bottom plate to the chassis, with the 6 #8 X 3/8 screws previously removed, using the center holes on each of the long sides and the two holes on each of the short sides. f) Replace the chassis on the shelf, positioning it exactly in the outline previously drawn. g) From the bottom side of the shelf, insert a #8 X 1" screw with a 1/2" flat washer against the head through each of the four front and rear holes. These screws engage the stamped nut over each hole on the chassis flange and when tightened secure the chassis to the shelf.

electrical installation

POWER

a) **POWER REQUIREMENTS:** The EICO Model HF-60 requires 200 watts at 110 to 120 volts, 60 cycles AC.

b) **REMOTE SWITCHING:** The EICO Model HF-60, although not provided with its own ON-OFF power switch, has provision for remote switching, through an octal socket mounted on the chassis. Pins 6 and 7 of the octal socket are internally connected to the ends of a break in one power transformer primary lead and are externally connected together by a jumper in a male octal plug inserted

in the octal socket. When this male plug is removed, pins 6 and 7 may be brought out to an external AC switch, usually in a preamplifier unit. This is one of the connection functions accomplished with the octal plug-and-cable attached to the EICO HF-61A preamplifier-control unit. If the HF-60 power amplifier is being used with a self-powered preamplifier, such as the EICO HF-61, or a self-powered tuner-preamplifier, the octal plug furnished with the HF-60 remains inserted in the octal socket (to connect the primary of the power transformer to the AC line and to ground one side of the filament winding) and the line cord of the HF-60 is inserted in a switched 117 VAC conven-

ience outlet in the control unit. Note: When using a self-powered preamplifier-control unit, touch one end of a wire to the preamplifier chassis and the other end to the power amplifier chassis. If a spark occurs, pull out the HF-60 line cord plug and re-insert it with the prongs reversed.

c) **POWERING AUXILIARY PREAMPLIFIER:** The same octal socket provides all necessary filament and B+ voltages for operating an auxiliary preamplifier-control unit. 6.3 volts AC filament voltage, at 1 ampere, may be obtained from pins 1 and 2; pin number 4 on the socket supplies 350 volts DC, at a maximum current of 10 milliamperes; and pin 3 is connected to ground. As stated above, control of 117 volt AC line power to the power amplifier, and, indirectly, power for the preamplifier-control unit itself, is made available through the connections to pins 6 and 7. This arrangement is exactly suitable for powering the EICO HF-61A preamplifier-control unit; all that need be done is to remove the octal plug provided with the HF-60 from the octal socket and insert the octal plug-and-cable of the HF-61A in its stead. Note that a jumper between pins 2 and 3 of the octal plug furnished with the HF-60 effectively grounds one side of the filament winding; removal of the octal plug leaves the filament winding floating. This arrangement is used because a hum balance control is connected across the filament leads in the EICO HF-61A preamplifier and the arm of this control is returned to a tap in the B+ supply to provide a superimposed DC potential on the filament supply for purpose of minimizing hum due to cathode-heater leakage in the preamplifier tubes.

d) **CONVENIENCE OUTLETS:** When the HF-60 is used with a preamplifier that takes power from it, such as the EICO HF61A, the convenience outlets of the HF-60 will be found useful. The outlet marked "117 VAC SW." ("SW." is an abbreviation for "SWITCHED") is "live" or "dead" depending on whether the preamplifier power switch turned to ON or OFF; plug tuners into this outlet. The outlet marked "117 VAC" is not switched and is "live" whenever the HF-60 line cord plug is inserted in a wall outlet; plug a record changer into this outlet in order to protect the mechanism. When the HF-60 is used with a self-powered preamplifier, such as the EICO HF-61A, normally the convenience outlets on the preamplifier will be used. However, the HF-60 outlets may be used also, if desired, in which case both of them will be "switched".

INTERCONNECTION OF COMPONENTS SIGNAL

a) **PREAMPLIFIER-CONTROL TO POWER AMPLIFIER:** Single conductor, shielded cable must be used to interconnect the preamplifier-control unit or tuner-preamplifier-control unit and the power amplifier. Unless the source has a low impedance output, such as a cathode follower (with which up to 50 ft. of cable can be used), use the shortest possible connection; in any case, use a low capacity type of shielded cable (as low as 25 mmf capacity per foot is available). Both ends of the cable must be fitted with RCA type phono plug connectors.

b) **SPEAKER CONNECTIONS:** To connect your speaker to the amplifier properly, you must know its rated impedance, which is usually marked on the speaker or specified in the manufacturer's literature. Connect one speaker lead to the terminal on the rear apron marked "G" and the other speaker lead to the nearby terminal designated by the rated speaker impedance (4, 8, or 16 ohms). Plastic-covered lamp cord may be used for distances up to 50 ft. with little power loss. For shorter distances, tv antenna lead can be used, particularly if it is desired to run the speaker lead under a rug.

If it is desired to use two similar or identical full-range speakers of the same rated impedance (either 8 or 16 ohms only) for better sound distribution, connect one speaker lead of each pair to "G" and the two remaining leads to the terminal with a number equal to half of one of the speaker's rated impedance. (It may be necessary to "phase" the two speakers by reversing both of the leads from one of the speakers.) This may not be done if each of the speakers is designed for reproduction of a different part of the audio spectrum (woofer-tweeter combinations), in which case a cross-over network is required which connects to the amplifier with only one pair of leads.

INTERCONNECTION PROCEDURE

a) Make all system interconnections before applying AC power. Making or breaking interconnections while AC power is applied will result in a momentary overload of both the power amplifier and speaker system with possible damage to either or both.

b) If the EICO HF-61A preamplifier control unit (not self-powered) has been obtained in kit form, remove all the jumper connections in the octal plug supplied with the HF-60 and wire the preamplifier power take-off leads to this plug as follows:

<u>Color of Preamp. Lead</u>	<u>Pin of Octal Plug Connected to</u>
grey	6
grey	7
brown	1
brown	2
red	4
black	3

Wired HF-61A preamplifiers will have the preamplifier leads connected to the octal plug as in the table above.

c) If it is desired to use a preamplifier without a power supply other than the HF-61A, the power take-off leads of the preamplifier should be connected to the HF-60 octal plug (after removing the jumpers) as follows:

<u>Preamp. Power Lead</u>	<u>Pin of Octal Plug Connected to</u>
AC ON-OFF	6
AC ON-OFF	7
filament (6.3 VAC)	1
filament (6.3 VAC)	2
B+	4 or 5*
ground	3

* If the preamplifier requires 350 VDC, use pin 4; if the preamplifier requires less than 350 VDC, use pin 5 and

connect a dropping resistor of appropriate value and voltage rating from pin 4 to pin 5 of the octal socket on the HF-60 chassis. For example, if the preamplifier in question requires 300 VDC B+ voltage at 10 ma drain, the dropping resistor will be required to drop the voltage by 50 volts ($350 - 300 = 50$) at a current of 10 ma. By Ohm's Law, the required resistance in ohms is the voltage drop in volts

divided by the current in amperes or $50 \text{ volts} / .01 \text{ amp.} = 5000 \text{ ohms}$. The power dissipated in the resistor in watts is equal to the voltage drop in volts multiplied by the current in amperes or $50 \text{ volts} \times .01 \text{ amp} = 0.5 \text{ watts}$. For safety a resistor of double the wattage rating should be used. Therefore, a 5000 ohm 1 watt resistor is required.

maintenance

CONTROL ADJUSTMENTS

There are three controls in the HF-60 amplifier. Two of these controls, the BIAS ADJ. and the BALANCE ADJ., must be adjusted by kit builders before initial use of the amplifiers—factory wired units will have had these adjustments made. The BALANCE ADJ. will have to be re-adjusted by all users whenever one or both of the EL34 output tubes is replaced or if it is suspected that a dc imbalance in the output tubes has occurred in the course of use. The third control is the INPUT LEVEL ADJ. which is set after all the systems components are interconnected and are actually operating. If the INPUT LEVEL ADJ. will not be accessible after mechanical installation, then the systems components should be interconnected and turned on before mechanical installation to permit the proper setting of this control.

a) PRELIMINARY BIAS & BALANCE ADJUSTMENTS: Before applying power, set both the BIAS ADJ. control and the BALANCE ADJ. control at the approximate center of their ranges of rotation. Then connect to AC power, turn the amplifier on, and allow about one minute for warm-up. If the plates of the EL34 output tubes turn cherry-red during warm-up, turn the BIAS ADJ. control counter-clockwise until redness is just barely visible (normal condition). If the redness does not disappear even at full counter-clockwise rotation, which indicates an abnormal condition, turn off the power and recheck the amplifier wiring and components.

b) SETTING BIAS ADJ. CONTROL (BIAS VOLTAGE ADJUSTMENT): Use either a VOM of at least 20,000 Ω per volt sensitivity and $\pm 3\%$ accuracy on dc voltage measurement or a VTVM. Set the instrument at the minus or negative DC volts functions and a range of not less than 50 volts or more than 150 volts (the closer the point on the scale at which the reading is made is to full scale, the more accurate it is). Rest the amplifier on the short side on which is located the input jack and remove the bottom plate. Locate the arm (center contact lug) of the BIAS ADJ. control and connect the "hot" meter lead to it. Touch the common or ground meter lead to any unpainted point on the chassis (ground) and read the negative dc

voltage on the meter. Adjust the BIAS ADJ. control for a reading of -47 dc volts (negative). Disconnect the meter leads when this is completed.

c) SETTING BALANCE ADJ. CONTROL: Set the VOM or VTVM at either the plus or minus DC voltage function and select the lowest DC voltage range. Connect the meter leads to the two METER pins jacks on the rear chassis apron. If the meter pointer deflects to the left of zero, reverse the leads. Adjust the BALANCE ADJ. control for a zero or minimum reading. This completes the balance adjustment, whereupon the meter leads can be removed from the METER pin jacks.

d) Set the VOM or VTVM at the plus DC voltage function and select the lowest DC voltage range (not higher than 3 volts full scale). Insert the "hot" meter lead into either one of the METER pin jacks and touch the common or ground meter lead to any unpainted point on the chassis (ground). Readjust the BIAS ADJ. control for a meter reading of 0.65 volt.

e) Repeat step c

f) Repeat step d

g) SETTING INPUT LEVEL ADJ. CONTROL: The INPUT LEVEL ADJ. control is intended to protect the speaker system from "blasting" should someone turn the preamplifier-control unit level controls to full, by permitting you to attenuate the preamplifier output signal by any desired amount at the input to the power amplifier where it can not be "fiddled" with. Start by setting the INPUT LEVEL maximum counter-clockwise (maximum attenuation), using a screwdriver. Set the LOUDNESS control on your preamplifier to the maximum clockwise position and the LEVEL control at the midpoint of its range of rotation. Turn your phonograph on and play on average orchestral record. Then slowly rotate the INPUT LEVEL ADJ. control clockwise until the music is at normal (or concert) listening level. This completes the adjustment, which need not be repeated.

TROUBLE SHOOTING and OPERATING NOTES

Your amplifier should require little service except for normal tube replacement. We recommend no substitutions for the tube types used in this amplifier. The 6F86, 6X4, and 6Z34 types are distributed nationally by the Amperex Electronic Corporation (230 Duffy Ave., Hicksville, L.I., N.Y.) and Mullard Ltd. (International Electronics Corp., 81 Spring St., N.Y. 12, N.Y.) If necessary, replacements can be obtained directly from EICO.

It should be noted that slight red coloring of the 6X4 output tube plates in operation is not abnormal and does not indicate that the amplifier is operating improperly.

The HF-60 is intended for operation at a line voltage of 117 volt AC. Component failure is likely at a line voltage above 124 volts AC. If the line voltage at your location is higher than 124 volts, use a voltage adjusting device or voltage regulator of adequate volt-ampere capacity (minimum 250 VA).

To facilitate servicing, remedial and trouble-shooting procedures have been provided in the TROUBLE SHOOTING CHART that follows. A VOLTAGE AND RESISTANCE CHART is also provided as an aid in locating defective components and to permit a careful, stage-by-stage check of the amplifier. DC operating voltages are given both at no signal and at a signal developing 50 watts output as well as the corresponding 1 kc signal voltages.

To isolate the source of unusual hum or noise in your system, first turn off the AC power and then unplug the audio cable connecting to the amplifier input. Then turn the AC power on again and note whether hum or noise has decreased. If it has, the fault is in the preamplifier or associated equipment and measures should be taken to correct it as described in the service notes for these units. If it is desired to provide a good building ground for your entire system, run a lead from under speaker connection terminal "G" to a cold water pipe. Do not connect such a ground wire to other components in the system.

If the trouble is no output or low output and the amplifier is suspected, check AC signal voltages starting at the input and working step-by-step toward the output, using a sine-wave audio signal generator and a VTVM. Turn the INPUT LEVEL ADJ. control maximum clockwise (no attenuation) and set the input signal to 0.4 volt. The corresponding grid and plate signal voltages for this input are indicated on the schematic diagram. This procedure should suffice to localize the defective stage.

If the trouble is an excessively distorted output, try tube replacement, signal tracing or proceed directly to voltage and resistance measurements.

When the defective stage is localized, proceed to a resistance and voltage check of the stage, using the data in the Resistance and Voltage chart. Disconnect the amplifier from the power line and discharge capacitors prior to making any resistance check and prior to removing either both of the 6X4 output tubes or disabling the bias supply. Do not turn the amplifier on with either of the output tubes removed or with the bias supply disabled.

CHECKING A TYPICAL TUBE STAGE

1. Check tube.
2. Check plate and cathode resistors.
3. Check coupling capacitors for leakage or short.
4. For output stage, check dc resistance of transformer windings.
5. Check grid leak resistor for open.
6. Check cathode by-pass capacitors for short.
7. If no or low B+ voltage on tube, check decoupling path for open or defective R9, and filter capacitor C10 and C11 for short.
8. If wiring and circuit components including the tube check O.K. and B+ voltage is excessive, check the decoupling path for short or defective R9.

SERVICE

If trouble develops in your instrument which you can not remedy yourself, write to our service department listing all possible indications that might be helpful. If desired, you may return the instrument to our factory where it will be placed in operating condition for \$5.00 plus the cost of parts replaced due to their being damaged in the course of construction. NOTE: Before returning this unit, be sure all parts are securely mounted. Attach a tag to the instrument, giving your home address and the trouble with the unit. Pack very carefully in a rugged container, using sufficient packing material (cotton, shredded newspaper, or excelsior), to make the unit completely immovable within the container. The original shipping carton is satisfactory, providing the original inserts are used or sufficient packing material is inserted to keep the instrument immovable. Ship by prepaid Railway Express, if possible, to Electronic Instrument Co., Inc., 33-00 Northern Blvd., Long Island City 1, N.Y. Return shipment will be made by express collect. Note that a carrier cannot be held liable for damages in transit if packing IN HIS OPINION, is insufficient.

GENERAL INSTRUCTIONS

The yellow-page section of this manual is the CONSTRUCTION section. It may be discarded at the completion of construction, if desired. The white-page section is the regular INSTRUCTION section and resumes on the white pages at the rear of the manual.

Care taken in the construction of this instrument will reward the constructor with many years of satisfactory service and greater confidence in his instrument. We urge you to not rush the construction, but to take all the time necessary for proper assembly and wiring.

Furthermore, we urge strongly that you follow the wire and parts layout shown in the pictorial diagrams as closely as possible. Very often wires are placed as shown for a good reason, and certainly the appearance of the completed instrument will be improved and the difficulty of finding a wiring error will be reduced by the following the wire and parts layout shown.

UNPACKING THE KIT: Unpack the kit carefully and check each part against the parts list including those parts that are mounted to the chassis. If you have trouble identifying any parts refer to the pictorial diagrams or the color code chart.

You will find that the value of a component will vary within the allowable circuit tolerance. For example, the $4.7K\Omega$, $\pm 10\%$ resistor may measure anywhere between $4.2K\Omega$ and $5.2K\Omega$. Tolerances on paper capacitors are substantially greater, and the tolerance for electrolytics is usually $\pm 100\%$ and -50% .

CONSTRUCTION HINTS: USE THE BEST GRADE OF ROSIN CORE SOLDER ONLY, preferably one containing the new activated fluxes such as Kester "Resin-Five", Ersa "Multicore" or similar types. UNDER NO CIRCUMSTANCES USE ACID CORE SOLDER OR ACID FLUX since acid flux can cause serious corrosion. Before soldering make a certain of a good mechanical connection. Use a clean, freshly tinned soldering iron, no smaller than 100 watts, and place the solder on the joint (not on the iron) so that the solder is melted by the heat from the joint itself. Do not remove the soldering iron until the solder flows and check to see that the resulting joint is smooth and shiny when the solder has cooled. There are two extremes to be avoided; too little heat and too much heat. If too little heat is supplied, the joint will appear pitted and grey, indicating a rosin joint which is unsatisfactory. On the other hand, if too much heat is applied to a joint, the parts connected to it may either change value, lose their protective coating, or break down. If you are soldering close to a part, hold the lead between the part and the joint being sol-

dered with the tip of a pair of longnose pliers. The pliers will conduct the heat away and prevent the component from being unduly overheated. If for any reason it is necessary to resolder a joint, be sure to use new solder.

It should also be noted that the leads on resistors, capacitors, and transformers are often longer than required. These leads should be trimmed to the proper length when necessary. Do not cut any lead until you have determined the required length when the lead is routed as shown in the diagrams.

BASIC TOOLS REQUIRED: These basic tools are required for the construction of the amplifier.

1. Screwdriver - $3/16"$ to $1/4"$ blade
2. Screwdriver - $1/8"$ blade
3. Longnose pliers - 5 or 6"
4. Diagonal cutters
5. Soldering iron (100 watts), or soldergun, or pencil iron (35 watts)
6. Gas pliers
7. High quality rosin or equivalent synthetic flux core solder. Do not use acid or paste flux under any circumstances.

A set of spintites and a wire stripper are also very useful supplementary tools.

PARTS IDENTIFICATION: Please note that very many of the parts for which color coding is given may not be color coded, but have their values and ratings printed. The letter K is a multiplier ($\times 1000$) and on resistors or capacitors indicates that the printed numerical value must be multiplied by one thousand to obtain the value in ohms or micro-micro farads respectively. Note also that one microfarad (mf) is equal to one million; micro-microfarads (mmf). To aid in rapid identification, keep in mind that 5%, 10%, and 20% resistors are color coded whereas 1% resistor have their values printed; also that molded tubular capacitors may or may not be color coded, whereas disc capacitors and electrolytics will always have their values printed. Please note the following relationships between the units used to express resistance or capacity.

1,000,000 ohms (Ω) = 1000 kilohms (K Ω) = 1 megohm (M Ω)
1,000,000 micro-micro farads (mmf) = 1 micro farads (mf)

CONSTRUCTION PROCEDURE: The complete step-by-step mounting and wiring procedure follows. To keep the drawings uncrowded, unnecessary repetition of mounting or wiring details may be omitted. Note: The abbreviation (C) means connect but do not solder (until other leads have been connected). The abbreviation (S) means connect and solder.

Bend the ground lug tabs on the sockets toward the chassis to prevent accidental shorting to the socket pins.

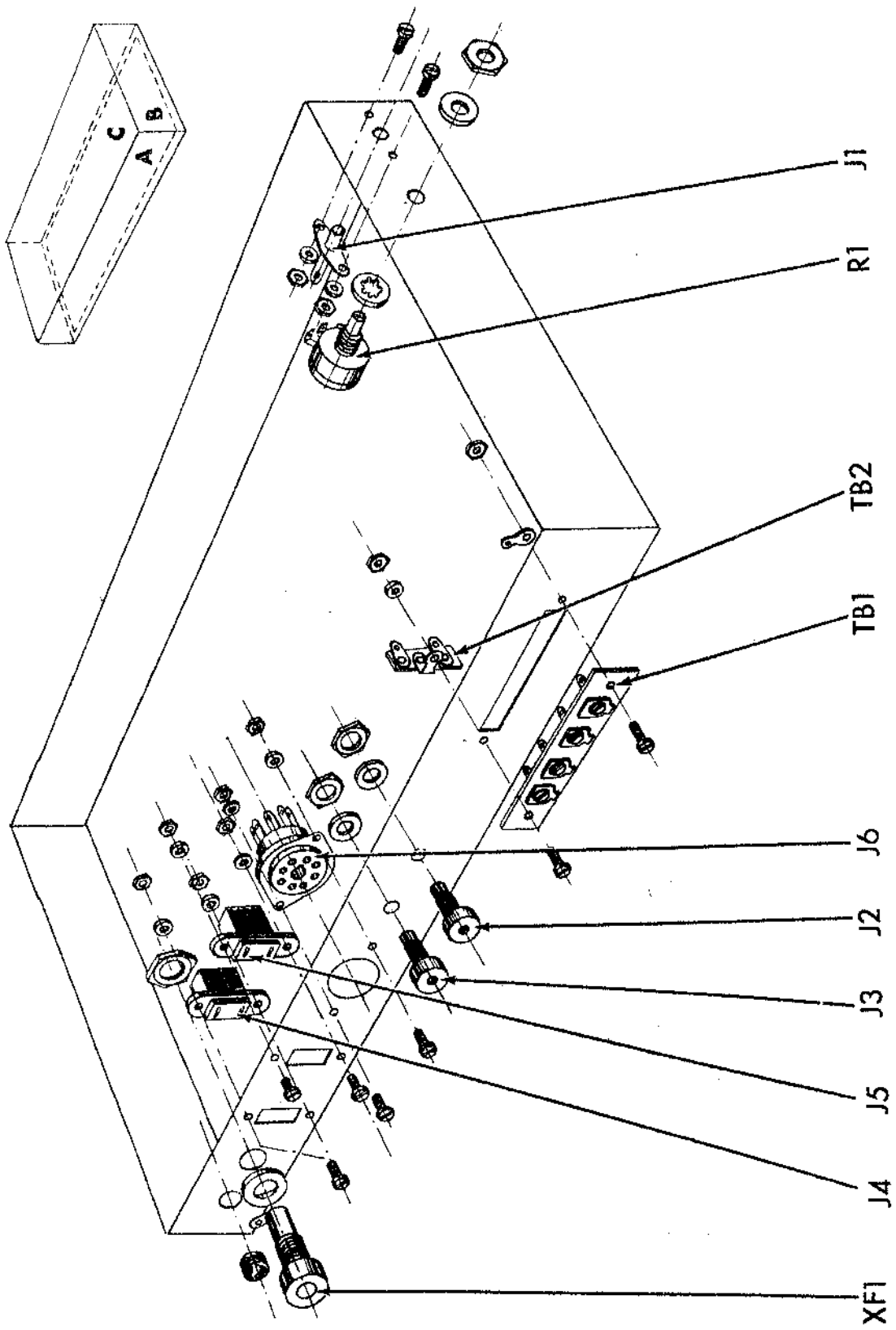

Fig. 1

CHASSIS MOUNTING

Fig. 1 shows the chassis laying bottom down, in which position the interior would actually be hidden from view. For the purpose of showing the mounting procedures clearly, Fig. 1 has been drawn as if the chassis were transparent. The long and short sides of the chassis to which parts are mounted have been designated side A and side B respectively, and the top of the chassis has been designated side C (see insert drawing).

1. () Fig. 1, side A. Mount the four post terminal board (SPEAKER CONNECTIONS) TBI on the outside of the apron. A two post terminal strip TB2 and a small ground lug are mounted on the inside as shown. Use two #6-32 X 1/4 screws, two #6 hex nuts and one #6 lockwasher.

2. () Fig. 1, side A. Mount the two pin jacks (METER) J2, J3, with the hardware supplied on same. Remove the nut and the fibre washer from the threaded portion of the jack. Pass same thru hole provided and attach the fibre washer and hex nut on the inside of the chassis. The small shoulder on the fibre washers should seat itself into the mounting hole. If the assembly is properly made the lug on the jack will be insulated from the chassis.

3. () Fig. 1, side A. Mount the octal socket, J6, (PREAMP POWER) as shown. Orient the socket so that the small notch (keyway) in the center of the bakelite section of the socket faces the meter jacks. This socket should be in-

serted from the inside of the chassis apron. Use two each of the following: #6-32 X 1/4 screws, #6 hex nuts and #6 lockwasher.

4. () Fig. 1, side A. Mount the convenience outlets J4, J5 (117VAC) inserting them from the inside of the chassis apron. To mount each outlet, use two of each of the following: #6-32 X 1/4 screws, #6 hex nuts and #6 lockwashers.

5. () Fig. 1, side A. Mount the fuseholder XF1, as shown. Secure the fuse holder with the large rubber washer and the largest nut supplied with the kit.

6. () Fig. 1, side A. Mount the 3/8" rubber grommet as shown. The groove around the rim of the grommet should fit over the rim of the hole. Squeeze grommet into oval shape to insert into hole, and work groove over the rim of the hole with a small screwdriver.

7. () Fig. 1, side B. Mount the input jack, J1 on the inside of the chassis. Use two of each of the following: #6-32 X 1/4 screws, #6 hex nuts and the #6 lockwashers.

8. () Fig. 1, side B. Mount the 1MΩ pot., P1, stock # 16016 (INPUT LEVEL ADJ.). Use one each of the following: 3/8-32 hex nut, 3/8 lockwasher and 3/8 flat washer.

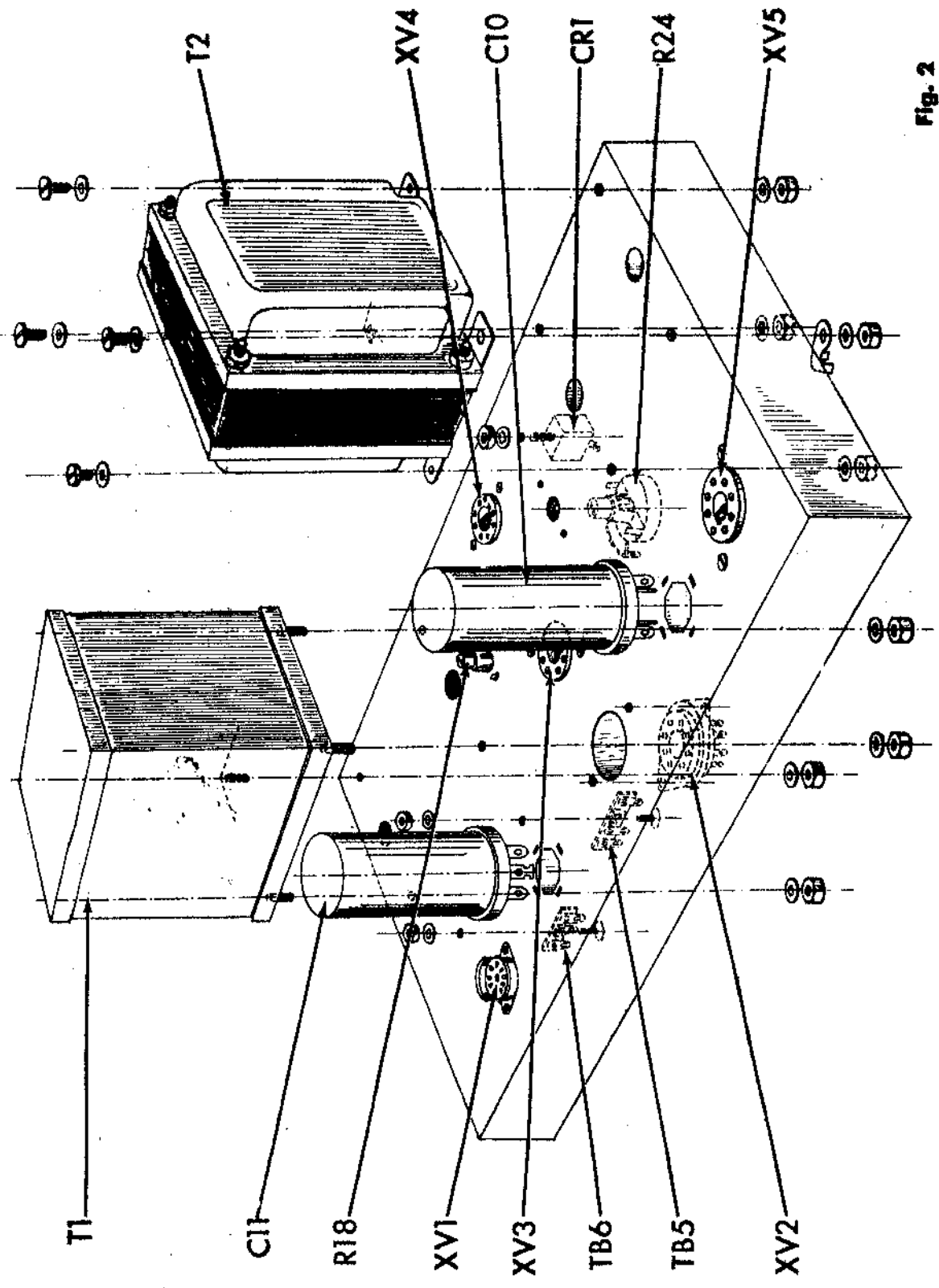
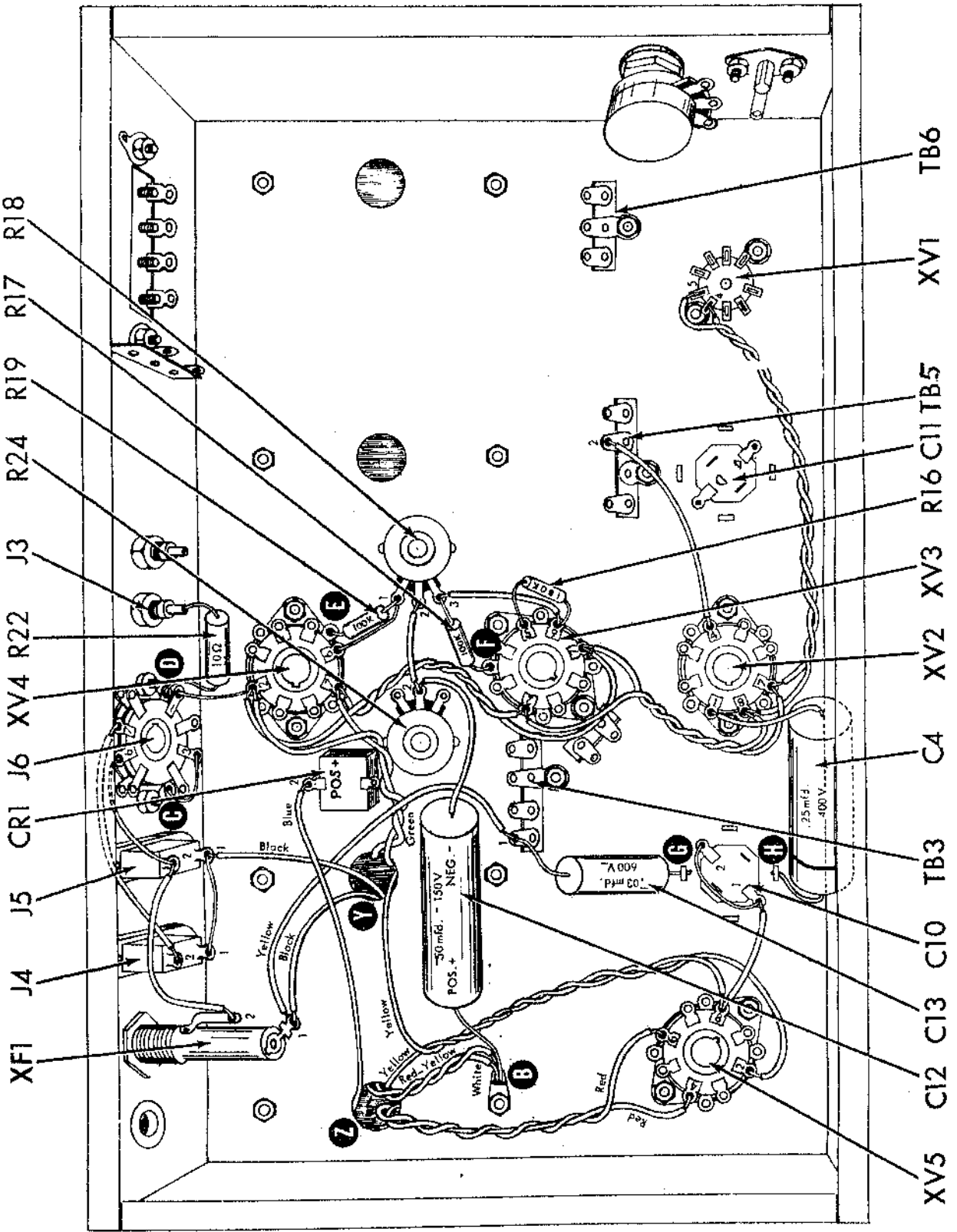

Fig. 2

CHASSIS MOUNTING CONT'D.

1. () Fig. 2, side C & Fig. 3. Mount the large octal sockets, XV2 to XV5, inserting them from the inside of the chassis. Refer to figure 3 for the proper orientation of the keyway of each socket. Please note that a one post right terminal strip with ground post is mounted on socket, XV3. Mount each socket using two each of the following: #6-32 X 1/4 screws, #6 hex nuts and #6 lockwashers.
2. () Fig. 2, side C & Fig. 3. Mount the 9 pin miniature socket, XV1. See Fig. 3 for proper orientation of keyway (missing pin). Use two each of the following: #4-40 X 1/4 screws, #4 lockwashers and #4 hex nuts.
3. () Fig. 2, side C & Fig. 3. Mount the 50ma rectifier, CR1, on the inside of the chassis near socket, XV4. See Fig. 3 for proper location. Please note that CR1 should be oriented so that the positive (+) side is located as shown. Use one #6 hex nut and one #6 lockwasher for mounting.
4. () Fig. 2, side C & Fig. 3. Mount the two post terminal strip with center ground post, TB6, as shown on Fig. 3. Use one each #6-32 X 1/4 screw, #6 hex nut, #6 lockwasher.
5. () Fig. 2, side C & Fig. 3. In a similar manner, mount the two post right, 1 post left terminal strip, TB5.
6. () Fig. 2, side C & Fig. 3. Likewise, mount the two post left, 1 post right terminal strip with a ground post, TB3.
7. () Fig. 2, side C & Fig. 4. Mount the output transformer, T1. Orient the transformer so that the proper colored leads emerge from holes "Y" and "W" on Fig. 3. Use four #10-32 hex nuts and four #10 lockwashers.
8. () Fig. 2, side C & Fig. 3. Mount the power transformer, T2. Orient the transformer so that the proper colored leads emerge from holes "Y" and "Z" on Fig. 3. Please note that ground lug "B" is mounted with the transformer. Use four each of the following: #10-32 X 3/8 screws, #10 flat washers, #10 lockwashers and #10 hex nuts and the large ground lug.
9. () Fig. 2, side C & Fig. 3. Mount the dual 20mfd capacitors, C10 and C11, on the top side of the chassis. Please note the position of the capacitor terminals on Fig. 3 before you secure it in place. The mounting tabs are inserted into the slots provided on the chassis and twisted somewhat less than a quarter turn. DO NOT twist the tabs excessively or they will shear off. Solder one mounting tab on each capacitor to chassis ground.
10. () Fig. 2, side C & Fig. 3. Mount the 10KΩ pot., R24, stock # 18015 (BIAS ADJ.) on the bottom side of the chassis. This pot is located near rectifier, CR1 and has its lugs pointing away from same, see Fig. 3. Position pot and press firmly toward chassis until a click is heard.
11. () Fig. 2, side C & Fig. 3. In a similar manner mount the 50KΩ pot., R18, stock # 18029 (BALANCED ADJ.).



XF1
 J4
 J5
 J6
 CR1
 XV4
 R22
 J3
 R24
 R19
 R17
 R18

XV5
 C12
 C13
 C10
 TB3
 C4
 XV2
 XV3
 R16
 C11
 TB5
 XV1
 TB6

Fig. 3

WIRING INSTRUCTIONS

1. () Fig. 3. Cut an 8" length of black wire and an 8" length of brown wire. Connect one end of the black wire to XV1-4 (S) and one end of the brown lead to XV1-5 (S). Twist the two leads and run along the chassis as shown. Connect the other end of the black lead to XV2-7 (C) and the other end of the brown lead to XV2-8 (C).
2. () Fig. 3. Following the above procedure, cut a 4" length of black wire and a 4 1/2" length of brown wire. Connect one end of the black wire to XV2-7 (S) and one end of the brown wire to XV2-8 (S). Twist the two leads and run along the chassis as shown. Connect the other end of the black lead to XV3-7 (C) and the other end of the brown lead to XV3-2 (C).
3. () Fig. 3. Following the above procedure, cut a 5" length of black wire and a 5" length of brown wire. Connect one end of the black wire to XV3-7 (S) and one end of the brown wire to XV3-2 (S). Twist the two leads and run along the chassis as shown. Connect the other end of the black lead to XV4-7 (C) and the other end of the brown lead to XV4-2 (C).
4. () Fig. 3. Connect a 1" piece of bare wire from XV4-2 (C) to J6-1 (S).
5. () Fig. 3. Connect a 5" piece of yellow wire from TB3-1 (C) to XF1-1 (C).
6. () Fig. 3. Cut one green lead from hole "Y" to 4" and the other green lead from hole "Y" to 4 1/2". Twist the leads. Connect the 4" lead to XV4-7 (C) and the 4 1/2" lead to XV4-2 (S).
7. () Fig. 3. Cut one black lead from hole "Y" to 3" and the other black lead from hole "Y" to 5 1/2". Connect the 3" lead to J5-1 (C) and the 5 1/2" lead to XF1-1 (S). Cut shorter lead to 3".
8. () Fig. 3. Cut the yellow lead from hole "Y" to 10" and the yellow lead from hole "Z" to 6". Twist leads as shown. Connect the 10" lead to XV5-2 (S) and the 6" lead to XV5-8 (C).
9. () Fig. 3. Cut the blue lead from hole "Z" to 6". Connect to CR1-2 (S).
10. () Fig. 3. Cut both the red-yellow and the white lead from hole "Z" to 3". Connect both to ground lug "B" (C) Twist leads.
11. () Fig. 3. Cut the two red leads from hole Z to 5 1/2". Twist leads as shown. Connect one lead to XV5-4 (S) and the other lead to XV5-6 (S).
12. () Fig. 3. Connect a 4" yellow lead from XF1-2 (S) to J5-2 (C).

13. () Fig. 3. Connect a 1 1/2" piece of bare wire from J5-2 (S) to J6-6 (S).
14. () Fig. 3. Connect a 3 1/2" yellow lead from J4-2 (C) to J6-7 (S).
15. () Fig. 3. Connect a 2" piece of bare wire from J4-1 (C) to J5-1 (S).
16. () Fig. 3. Connect a 1" piece of bare wire from J6-3 (S) to ground lug "C" (S) on J6.
17. () Fig. 3. Connect a 10Ω, 1% resistor, R22, from J3 (C) to ground lug "D" (S) on J6. Both leads of the resistor should be cut to 3/4".
18. () Fig. 3. Connect a 100KΩ (brown, black, yellow, gold) 5% resistor, R19, from R18-1 (C) to ground lug "E" (S) on XV4. Cut both leads to 1 1/2".
19. () Fig. 3. Connect a 1 1/2" bare lead from R18-1 (S) to XV4-6 (C).
20. () Fig. 3. Connect a 2" yellow lead from R18-2 (S) to R24-2 (C).
21. () Fig. 3. Connect a 100KΩ (brown, black, yellow, gold) 5% resistor, R17, from R18-3 (C) to ground lug "F" (S) on XV3. Cut both leads to 1 1/2".
22. () Fig. 3. Connect a 2" green lead from R18-3 (S) to XV3-6 (C).
23. () Fig. 3. Connect the 50mfd, 150V electrolytic capacitor, C12, from R24-2 (S) to ground lug "B" (C). The + side goes to the ground lug. The lead to the ground lug is 1 1/2" long and the lead to R24 is 2 1/2" long, covered with 2 1/4" of spaghetti.
24. () Fig. 3. Connect the .03mfd (orange, black, orange, black, blue) molded capacitor, C13, from TB3-1 (S) to ground lug "G" (S) on capacitor, C10. Cut both leads to 3/4".
25. () Fig. 3. Connect a 3" red lead from XV5-8 (S) to C10-1 (C).
26. () Fig. 3. Connect a 1 1/2" bare lead from C10-1 (S) to C10-2 (C).
27. () Fig. 3. Connect a .25mfd, 400V (red, green, yellow, white, yellow) molded capacitor, C4, from XV2-1 (C) to ground lug "H" (S). The lead to the ground lug is 1" long and the lead to XV2-1 is 1 1/2" long covered with 1 1/4" of spaghetti.
28. () Fig. 3. Connect a 4" green lead from XV2-4 (C) to TB5-2 (C).
29. () Fig. 3. Connect a 180KΩ, 5% (brown, grey, yellow, gold) resistor, R16, from XV3-6 (S) to XV3-5 (C).

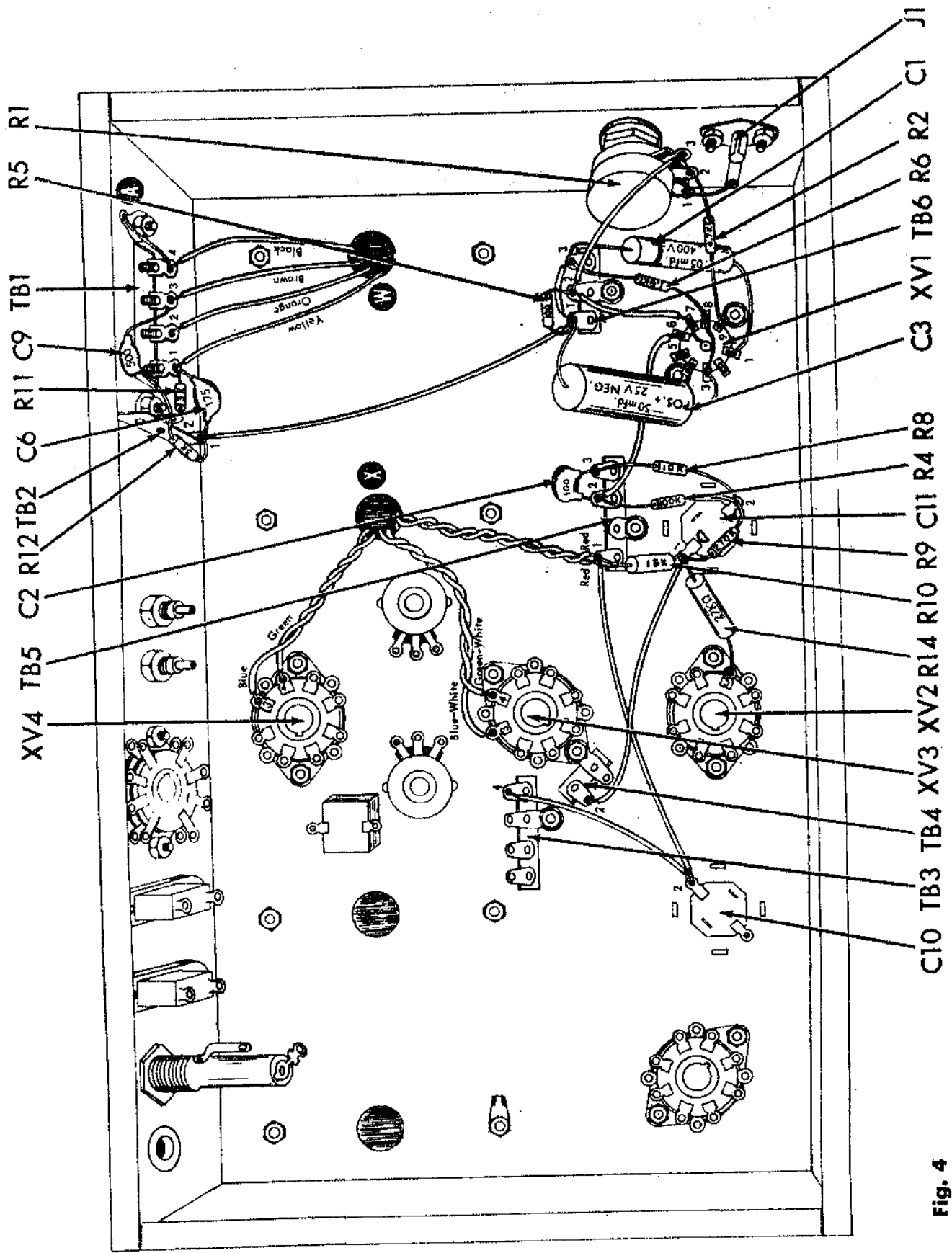

Fig. 4

WIRING INSTRUCTIONS CONT'D

1. () Fig. 4. Connect a 5" red lead from C11-1 (C) to TB4-2 (C).
2. () Fig. 4. Connect a 4" red lead from C10-2 (C) to TB3-4 (C).
3. () Fig. 4. Connect a 6" red lead from C10-2 (S) to TB5-1 (C).
4. () Fig. 4. Connect a 27K Ω (red, violet, orange, gold) 5% resistor, R14, from XV2-5 (C) to C11-1 (C). Cut both leads to 3/4".
5. () Fig. 4. Connect a 270K Ω (red, violet, yellow, silver) 10% resistor, R9, from C11-1 (C) to C11-2 (C). Cut both leads to 1/2".
6. () Fig. 4. Connect a 15K Ω (brown, green, orange, silver) 10% resistor, R10, from C11-1 (S) to TB5-1 (C). Cut both leads to 1/2".
7. () Fig. 4. Connect a 100K Ω (brown, black, yellow, gold) 5% resistor, R4, from C11-2 (C) to TB5-2 (C). Cut both leads to 3/4".
8. () Fig. 4. Connect a 3" green lead from XV1-6 (S) to TB5-2 (C).
9. () Fig. 4. Connect a 100mmf disc capacitor, C2, from TB5-2 (S) to TB5-3 (C). Cut both leads to 1/2".
10. () Fig. 4. Connect a 10K Ω (brown, black, orange, silver) 10% resistor, R8, from C11-2 (C) to TB5-3 (S). Cut both leads to 1".
11. () Fig. 4. Connect a 1 1/2" black lead from TB6-1 (C) to TB6-3 (C).
12. () Fig. 4. Connect a 2 3/4" black lead from TB6-2 (C) through XV1-7 (S) to XV1-center post (S).
13. () Fig. 4. Connect a 1.6K Ω (red, blue, red, silver) 5% resistor, R6, from TB6-3 (C) through XV1-8 (S) to XV1-3 (C). Use a 1/2" piece of spaghetti between pins XV1-8 and XV1-3. Cut the lead to TB6 to a 1" length and the other lead to a 1 1/2" length.
14. () Fig. 4. Connect a .05mf (green, black, orange, white, yellow) capacitor, C1, from TB6-3 (S) to XV1-1 (C). Cut the lead to TB6 to a 3/4" length and the other lead to a 1 1/4" length. Use a 1" piece of spaghetti on the 1 1/4" lead.
15. () Fig. 4. Connect a 1 1/2" piece of bare wire from J1 (S) to R1-1 (S).
16. () Fig. 4. Connect a 2" black lead from R1-3 (S) to TB6-2 (C).
17. () Fig. 4. Connect a 6" black lead from TB2-1 (C) to TB6-1 (C).
18. () Fig. 4. Cut the two red leads from hole "X" to 4". Twist the leads together and connect both leads to TB5-1 (S).
19. () Fig. 4. Cut the green-white lead from hole "X" to 3 1/2" and the blue-white lead to 4". Twist the leads together; then connect the green-white to XV3-4 (S) and the blue-white to XV3-3 (C).
20. () Fig. 4. Cut the green lead from hole "X" to 3" and the blue lead to 3 1/2". Twist the leads together; then connect the green lead to XV4-4 (S) and the blue lead to XV4-3 (S).
21. () Fig. 4. Cut all leads from hole "W" to 3 1/4". Connect the black lead to TB1-4 (C), the brown lead to TB1-3 (C), the orange lead to TB1-2 (S) and the yellow lead to TB1-1 (C).
22. () Fig. 4. Connect a 1 1/4" bare lead from TB1-4 (S) to ground lug "A" (S).
23. () Fig. 4. Connect a 175mmf disc capacitor, C6, from TB1-1 (C) to TB2-1 (C). Cut each lead to 3/4". Use 1/2" spaghetti on each lead.
24. () Fig. 4. Connect a 3K Ω (orange, black, red, gold) 5% resistor, R11, from TB1-1 (S) to TB2-2 (C). Cut each lead to 1/2".
25. () Fig. 4. Connect a 500mmf disc capacitor, C9, from TB1-3 (S) to TB2-2 (C). Cut each lead to 1". Use 3/4" spaghetti on each lead.
26. () Fig. 4. Connect a 3K Ω (orange, black, red, gold) 5% resistor, R12, from TB2-2 (S) to TB2-1 (S). Cut each lead to 3/4".
27. () Fig. 4. Connect a 4.7K Ω (yellow, violet, red, silver) 10% resistor, R2, from R1-2 (S) to XV1-9 (S). Cut leads to 3/4".
28. () Fig. 4. Connect a 100 Ω (brown, black, brown, gold) 5% resistor, R5, from TB6-2 (S) to TB6-1 (C). Cut leads to 1/2".
29. () Fig. 4. Connect a 50mfd, 25V electrolytic capacitor, C3, from XV1-3 (S) to TB6-1 (S). Connect + side to XV1-3. Cut leads to 3/4".

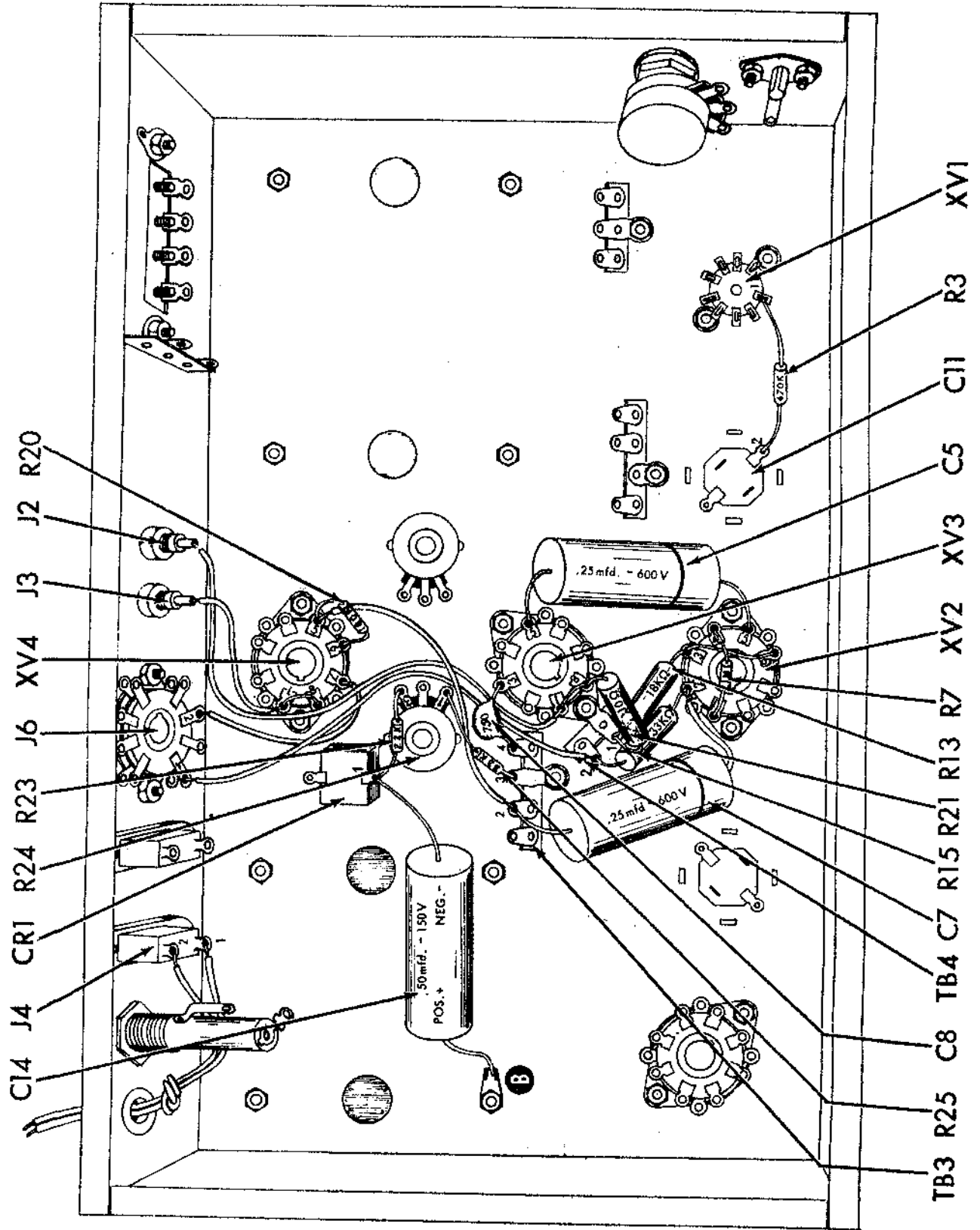

Fig. 5

1. () Fig. 5. Connect a 470K Ω (yellow, violet, yellow, gold) 5% resistor, R3, from XV1-1 (S) to C11-2 (S). Cut leads to 1". Use 3/4" spaghetti on each lead.
2. () Fig. 5. Connect a .25mf, 600V (red, green, yellow, white, blue) molded capacitor, C5, from XV3-5 (S) to XV2-5 (S). Cut leads to 1".
3. () Fig. 5. Connect an 18K Ω (brown, grey, orange, gold) 5% resistor, R13, from TB4-1 (C) through XV2-3 to XV2-6 (S). Use a 5/8" piece of spaghetti between XV2-3 and XV2-6. Cut the lead going to TB4 to 3/4" and the other lead to 1 1/2".
4. () Fig. 5. Connect a 1 meg (brown, black, green, silver) 10% resistor, R7, from XV2-1 (S) to XV2-4 (S). Cut leads to 1/2".
5. () Fig. 5. Connect a 33K Ω , 1W (orange, orange, orange, gold) 5% resistor, R15, from XV2-2 (C) to TB4-2 (C). Cut leads to 1 1/4".
6. () Fig. 5. Connect a .25mf, 600V (red, green, yellow white, blue) molded capacitor, C7, from XV2-2 (S) to TB3-2 (C). Cut one lead to 3/4" and the other lead to 1 1/2". Use 1" spaghetti on the longer lead and connect this to XV2-2.
7. () Fig. 5. Connect a 3/4" bare wire from XV3-1 (C) to XV3-8 (C).
8. () Fig. 5. Connect a 10 Ω , 1% resistor, R21 from XV3-8 (S) to TB4-1 (S).
9. () Fig. 5. Connect a 4 1/2" green lead from TB3-2 (S) to XV4-5 (C).
10. () Fig. 5. Connect a 33K Ω , 1/2W (orange, orange, orange, silver) 10% resistor, R25, from R24-1 (S) to TB3-3 (S). Cut leads to 3/4".
11. () Fig. 5. Connect a 22K Ω (red, red, orange, silver) 10% resistor, R23, from R24-3 (S) to CR1-1 (C). Cut leads to 3/4".
12. () Fig. 5. Connect a 50mf, 150V electrolytic capacitor, C14, from CR1-1 (S) to ground lug "B" (S). Cut the lead on the + side to 1 3/4" and connect this to the ground lug. Cut the other lead to 1 3/4" and cover it with a 1 1/2" piece of spaghetti before connecting it to CR1.
13. () Fig. 5. Connect a 750mmf disc capacitor, C8, from TB3-4 (S) to XV3-3 (S).
14. () Fig. 5. Connect a 6" red lead from TB4-2 (S) to J6-4 (S).

15. () Fig. 5. Connect a 7" yellow lead from XV3-1 (S) to J2 (S).
16. () Fig. 5. Connect a 180K Ω (brown, grey, yellow, gold) 5% resistor, R20, from XV4-6 (S) to XV4-5 (S). Cut leads to 1/2".
17. () Fig. 5. Connect a 3" black lead from XV4-7 (S) to J6-2 (S).
18. () Fig. 5. Connect a 3/4" bare wire from XV4-8 (S) to XV4-1 (C).
19. () Fig. 5. Connect a 2 1/2" black lead from XV4-1 (S) to J3 (S).
20. () Fig. 5. Pass the line cord through the 3/8 grommet at the rear of the chassis. Knot the line cord inside the chassis 2 1/2" from the end. Connect one lead to J4-1 (S) and the other lead to J4-2 (S).

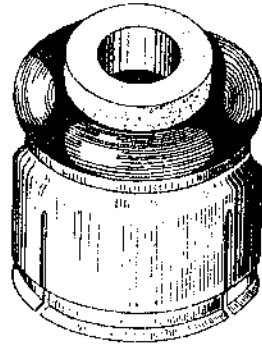
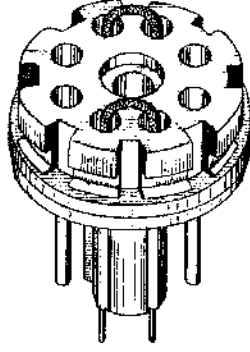

Fig. 6

21. () Fig. 6. Cut two 2" lengths of black hook-up wire. Strip 3/4" of insulation from both ends of each. This will leave 1/2" of insulation at the exact center of each wire. Bend each wire into a "U" shape. One will be used as a jumper between pins 2 and 3 of the octal plug and the other as a jumper between pins 6 and 7 of the octal plug.
22. () Fig. 6. Push one end of one lead into pin 2 of the octal plug and the other end of the same lead into pin 3. When the lead ends have reached the ends of the pins, only the insulation will be visible at the rear of the plug.
23. () Fig. 6. Similarly connect plug pins 6 and 7 with the other 2" lead.
24. () Fig. 6. Form a puddle of solder at the tip of the soldering iron. Hold the plug with the pins down directly above the tip of the soldering iron. Dip each of the pin-ends into which wires have been inserted one at a time into the solder puddle and hold there for several seconds until the solder rises up into the pin by capillary action.
25. () Fig. 6. Press the cap down over the octal plug. It may be left off if there is inadequate room at the desired location for mounting the chassis.

26. See a 2nd edition

FINAL STEPS

You have now completed the assembly and wiring of your amplifier. When you have completed the following steps your amplifier will be ready for use.

- 1) To catch any wiring errors, it is suggested that the entire wiring be checked point-by-point against the wiring instructions (and preferably also against the schematic wiring diagram in order to become more familiar with the component layout and circuitry). While doing so, check for rosin joints, loose lumps of solder, poor lead dress, and accidental shorts or leakage paths arising from the flow of rosin between contacts (remove with a stiff brush dipped in carbon tetrachloride).
- 2) Clean socket XV1 with carbon tetrachloride using a stiff brush. It is also advisable to remove the tube and shield from XV1, and clean the socket and pins on top of the chassis.
- 3) Insert tubes V1 through V5 in their correct sockets and the fuse in the fuse holder. Place a shield over V1.
- 4) Insert the octal plug into octal socket J6.

5) IMPORTANT: BE SURE TO MAKE THE FOLLOWING RESISTANCE CHECKS AND BIAS ADJ., BALANCE ADJ. CONTROL ADJUSTMENTS BEFORE CONNECTING TO THE AC LINE: Check for a cold dc resistance of 1.2 ohms across the AC plug; check for a resistance of at least 45 ohms between ground and pins 4 and 6 of XV5, and 9 ohms between ground and the positive terminal of rectifier, CR1; check for a resistance of at least 200K ohms between pin 8 of the rectifier tube V5 and ground. Allow sufficient time for the electrolytic capacitors to be charged by the ohmmeter battery in this last measurement. These measurements constitute a reasonable check of the power supply components and wiring before applying power. If you fail to obtain these resistance values, do not proceed to the next step until the cause is discovered and the condition remedied. If the measurements are satisfactory, proceed to **CONTROL ADJUSTMENTS** in the **MAINTENANCE** section of the book. **DO NOT CONNECT TO THE AC LINE** until you have completed the preliminary **BIAS ADJ.** and **BALANCE ADJ.** control adjustments, at which point you will be instructed to do so. When you have completed the **CONTROL ADJUSTMENTS**, proceed to the step following this one, after having disconnected the amplifier from the AC line.

- 6) Press a speed nut in place over each hole on the bottom flange of the chassis (see Fig. 7).

7) If the amplifier is not going to be fastened to some surface, insert the rubber feet in the openings provided in the bottom plate and mount the bottom plate on the chassis, using 10 #8-32 X 3/8" screws. Do not use the 1" long screws for this purpose (possibility of shorting input jack). If the amplifier is to be fastened to a surface, the feet will not be used and the bottom plate will be required as a template before it is attached to the amplifier.

8) Read the **MECHANICAL INSTALLATION** and **ELECTRICAL INSTALLATION** sections of the instruction book carefully, and install and connect the amplifier according to the information given.

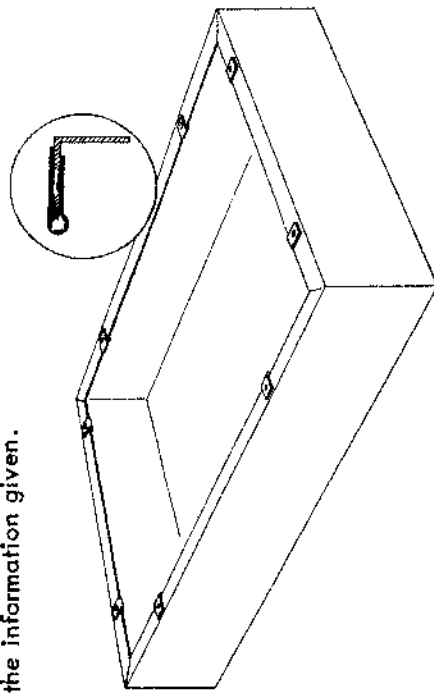

Fig. 7

SERVICE

If you are still having difficulty, write to our service department listing all possible indications that might be helpful. If desired, you may return the instrument to our factory where it will be placed in operating condition for \$5.00 plus the cost of parts replaced due to their being damaged in the course of construction. This service policy applies only to completed instruments constructed in accordance with the instructions as stated in the manual. Instruments that are not completed or instruments that are modified will not be accepted for repair. Instruments that show evidence of acid core solder or paste fluxes will be returned not repaired. **NOTE:** Before returning this unit, be sure all parts are securely mounted. Attach a tag to the instrument, giving your home address and the trouble with the unit. Pack very carefully in a rugged container, using sufficient packing material (cotton, shredded newspaper, or excelsior), to make the unit completely immovable within the container. The original shipping carton is satisfactory, providing the original inserts are used or sufficient packing material is inserted to keep the instrument immovable. Ship by prepaid Railway Express, if possible, to the Electronic Instrument Co., Inc., 33-00 Northern Blvd. L.I.C. 1, New York. Return shipment will be made by express collect. Note that the carrier cannot be held liable for damages in transit if packing, **IN HIS OPINION**, is insufficient.

TROUBLE SHOOTING CHART

SYMPTOM	CAUSE	REMEDY
House power line fuse blows; fuse, F1, remains intact.	Short in line cord, J4, J5 or associated equipment plugged into J4 or J5.	repair
Fuse, F1, blows.	<p>If the amplifier causes a replacement fuse to blow with rectifier tube, V5 is removed, primary or high voltage secondary windings of T2 are incorrectly wired or shorted.</p> <p>If F1 does not blow after replacement (with V5 removed), check for bias supply failure, short in B+ circuits, defective V5, C10, C11.</p>	<p>check and repair or replace.</p> <p>check and repair or replace.</p>
V5 filament not lit.	Incorrect wiring of fil. leads to V5 socket. 5V fil. winding of T2 open.	<p>repair</p> <p>replace T2.</p>
Any or all other tube filament	Open lead from 6.3V winding of T2. 6.3V winding of T2 open.	<p>repair</p> <p>replace T2.</p>
DC voltage at V5 cathode (pin 8) is incorrect as specified below.		
a) No voltage	Defective V5. C10, C11 shorted internally or externally.	<p>replace</p> <p>replace or repair</p>
b) High voltage	<p>Connection to C10 from pin 8 of V5 broken.</p> <p>Connection to center tap of h.v. sec. winding of T2 open.</p> <p>Output tubes V3 & V4 over-biased or not drawing current.</p>	<p>repair</p> <p>repair</p> <p>see trouble-shooting typical stage; adjust bias and balance control.</p>
c) Low voltage	<p>Excessive current drain amplifier.</p> <p>Defective V7.</p>	<p>see trouble-shooting typical stage; adjust bias and balance controls.</p> <p>replace</p>

VOLTAGE AND RESISTANCE CHART

TUBE	PIN#	DC VOLTS NO SIGNAL	DC VOLTS 50 W OUT	AC VOLTS (1kc) 50W OUT	RESISTANCE UNIT OFF
EF86/Z729 V1	1	94	88	0.45	1.2 Meg Ω
	2	0	0	0	0
	3	2.2	2	0.45	2.3 K Ω
	4 & 5	filament (6.3V AC between)			-
	6	82	74	5.5	500 K Ω
	7	0	0	0	0
	8	2.2	2	0.45	2.3 K Ω
	9	0	0	.52	1 Meg Ω
6SN7GTB V2	1	76	71	.0042	1.5 Meg Ω
	2	310	285	34.5	50 K Ω
	3	92	87	2.7	19 K Ω
	4	82	74	5.5	500 K Ω
	5	310	285	34.5	46 K Ω
	6	92	87	2.7	19 K Ω
	7 & 8	filament (6.3V AC between)			-
EL34/6CA7 V3	1	.65	1.2	1.3	10 Ω
	2 & 7	filament (6.3V AC between)			-
	3	470	440	240	70 Ω
	4	470	440	100	35 Ω
	5	-38.5	-37.5	34.5	230 K Ω
	6	-39	-39	-	34 K Ω
	8	.65	1.2	1.3	10 Ω
EL34/6CA7 V4	1	.65	1.2	1.3	10 Ω
	2 & 7	filament (6.3V AC between)			-
	3	470	440	240	79 Ω
	4	470	440	100	29 Ω
	5	-38.5	-37.5	34.5	230 K Ω
	6	-39	-39	-	34 K Ω
	8	.65	1.2	1.3	10 Ω
GZ34 V5	1	-	-	-	-
	2	filament 470 (5.0V AC to pin 8—remove tube to measure)			above 200K Ω
	3	-	-	-	-
	4	-	-	393	50 Ω
	5	-	-	-	-
	6	-	-	393	50 Ω
	7	-	-	-	-
	8	filament & cathode 470 440			above 200K Ω

All voltages and resistances are measured to chassis with the input level control set maximum clockwise (full gain) and Bias Adjust and Balance Adjust controls set for proper bias voltage and correct balance respectively. Voltages are measured with a high input impedance VTVM. All resistance measurements are made with pin 8 of the GZ34 grounded except, of course, when the resistance to ground at pins 2 and 8 of the GZ34 is being checked. Operating line voltage at which voltage measurements are made is 117 volts AC, 60cps. NOTE: ALL VOLTAGE & RESISTANCE VALUES MAY VARY NORMALLY BY $\pm 15\%$.

REPLACEMENT PARTS LIST CONTINUED

40000	#6-32 hex nuts	22
40001	3/8 hex nut	1
40005	nuts, hex, #10-24	8
40007	nut, hex, #4-40	2
40016	nut, hex, 1/2-24	1
40017	nut, tinnerman, #8-32	10
41000	screw, 6-32 X 1/4	21
41003	screw, 8-32 X 3/8	10
41006	screw, 10-24 X 3/8	4
41016	screw, #4-40 X 1/4	2
41028	screw, #8-32 X 1	4
42000	washer, lock, 3/8	1
42001	washer, flat, 3/8	1
42002	washer, lock, #6	21
42004	washer, lock, #10	8
42007	washer, lock, #4-40	2
42011	washer, flat, #10	4
42029	washer, rubber, 1/2 ID	1
42032	washer, flat, #8, 7/16" O.D.	4
43000	lug, ground, #6	1
43004	lug, ground, large	1
46000	✓grommet, 3/8	1
46006	✓bumper, rubber	4
51006	✓plug, RCA type	1
51007	✓octal plug and hood	1
57000	✓line cord	1
81093	✓chassis	1
81097	✓bottom plate	1
97300	✓tube shield	1
66046	manual of instruction (wired)	1
66301	✓manual of instruction (kit)	1

NOTE: When ordering replacement parts, please include all of the following information: 1) stock number and description given in parts list; 2) quantity; 3) model number of instrument; 4) serial number of instrument (on panel). This information will expedite the processing of your order and insure your receiving the correct replacement parts.

REPLACEMENT PARTS LIST

<u>Stk.#</u>	<u>Symbol</u>	<u>Description</u>	<u>Am't.</u>
20042	C1	✓cap., molded, .05mfd-400V, 10% (green, black, orange, white, yellow)	1
22509	C2	✓cap., disc., 100mmf, 10%	1
23007	C3	✓cap., elec., 50mfd-25V	1
20044	C4	✓cap., molded, .25mfd-400V, 10% (red, green, yellow, white, yellow)	1
20041	C5,7	✓cap., molded, .25mfd-600V, 10% (red, green, yellow, white, blue)	2
22535	C6	✓cap., disc., 175mmf-10%	1
22542	C8	✓cap., disc., 750mmf-1000V, 10%	1
22515	C9	✓cap., disc., 500mmf, 10%	1
24007	C10,11	✓cap., elec., 2 X 20mfd-500V	2
23015	C12,14	✓cap., elec., 50mfd-150V	2
20043	C13	✓cap., molded, .03mfd-600V, 20% (orange, black, orange, black, blue)	1
93003	CR1	✓rectifier, 50ma	1
91005	F1	✓fuse, 3A	1
50014	J1	✓jack, phono-input, single	1
50007	J2,3	✓jack, pin	2
50014	J4,5	✓outlet, convenience	2
97032	J6	✓jack, power, octal socket	1
16016	R1	✓pot., 1MΩ audio taper (Input Level Adj.)	1
10430	R2	✓res., 4.7KΩ, 1/2W, ±10% (yellow, violet, red, silver)	1
11531	R3	✓res., 470KΩ, 1/2W, ±5% (yellow, violet, yellow, gold)	1
11527	R4,17,19	✓res., 100KΩ, 1/2W, ±5% (brown, black, yellow, gold)	3
11505	R5	✓res., 100Ω, 1/2W, ±5% (brown, black, brown, gold)	1
11542	R6	✓res., 1.6KΩ, 1/2W, ±5% (red, blue, red, silver)	1
10407	R7	✓res., 1MΩ, 1/2W, ±10% (brown, black, green, silver)	1
10400	R8	✓res., 10KΩ, 1/2W, ±10% (brown, black, orange, silver)	1
10419	R9	✓res., 270KΩ, 1/2W, ±10% (red, violet, yellow, silver)	1
10852	R10	✓res., 15KΩ, 1W, ±10% (brown, green, orange, silver)	1 2
11513	R11,12	✓res., 3KΩ, 1/2W, ±5% (orange, black, red, gold)	2
11600	R13	✓res., 18KΩ, 1W, ±5% (brown, grey, orange, gold)	1
11601	R14	✓res., 27KΩ, 1W, ±5% (red, violet, orange, gold) 28.75	1
11602	R15	✓res., 33KΩ, 1W, ±5% (orange, orange, orange, gold)	1
11537	R16,20	✓res., 180KΩ, 1/2W, ±5% (brown, grey, orange, gold)	2
18029	R18	✓pot., 50KΩ, linear taper (balance adj.)	1
11703	R21,22	✓res., 10Ω, 1W, ±1%	2
10424	R23	✓res., 22KΩ, 1/2W, ±10% (red, red, orange, silver)	1
18015	R24	✓pot., 10KΩ, linear taper (bias adj.)	1
10426	R25	✓res., 33KΩ, 1/2W, ±10% (orange, orange, orange, silver)	1
32006	T1	✓transformer, output	1
30020	T2	✓transformer, power	1
54500	TB1	✓terminal board, 4 post (speaker connections)	1
54003	TB2	✓terminal strip, 2 post	1
54015	TB3	✓terminal strip, 2 post left, 1 post right w/ground - <i>Orphan</i>	1
54002	TB4	✓terminal strip, 1 post right w/ground	1
54006	TB5	✓terminal strip, 2 post right, 1 post left	1
54004	TB6	✓terminal strip, 2 post w/ground	1
90042	V1	✓tube, EF86/Z729	1
90041	V2	✓tube, 6SN7GTB	1
90040	V3,4	✓tube, EL34/6CA7	2
90044	V5	✓tube, GZ34	1
97800	XF1	✓fuseholder	1
97027	XV1	✓socket, 9 pin min., top mount	1
97032	XV2-5	✓socket, octal, bottom mount	4 5

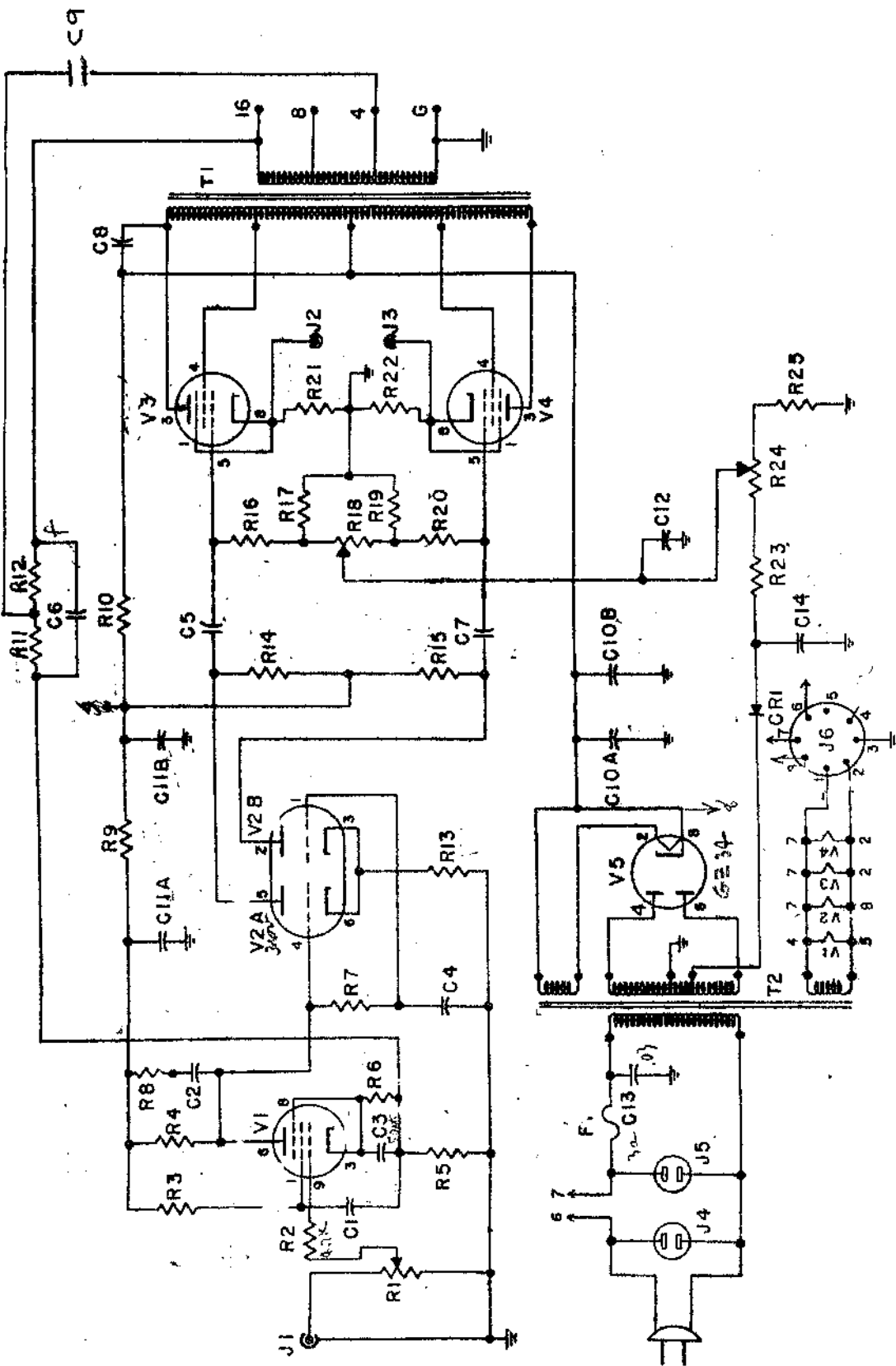

Sym.	Description	Sym.	Description	Sym.	Description	Sym.	Description
C1	cap., .05 mfd-400V, 10%	R12	res., 3KΩ, 1/2W, ±5%	V1	6V tube, EF86/2729	R13	res., 1MΩ audio taper (Input Level Adj.)
C2	cap., 100 mfd, 10%	R13	res., 18KΩ, 1W, ±5%	V2	6Z3A tube	R14	res., 4.7KΩ, 1/2W, ±10%
C3	cap., 50 mfd-25V	R14	res., 27KΩ, 1W, ±5%	V3	6SN7GTB tube	R15	res., 470KΩ, 1/2W, ±5%
C4	cap., .25 mfd-400V, 10%	R15	res., 33KΩ, 1W, ±5%	V4	6X4 tube	R16	res., 100KΩ, 1/2W, ±5%
C5	cap., .25 mfd-400V, 10%	R16	res., 100KΩ, 1/2W, ±5%	V5	6CA7 tube	R17	res., 100KΩ, 1/2W, ±5%
C6	cap., 175 mfd, 10%	R17	res., 1.6KΩ, 1/2W, ±5%	V6	6X4 tube	R18	res., 100KΩ, 1/2W, ±5%
C7	cap., .25 mfd-400V, 10%	R18	res., 1MΩ, 1/2W, ±10%	V7	6V tube	R19	res., 10KΩ, 1/2W, ±10%
C8	cap., 750 mfd-100V, 10%	R19	res., 10KΩ, 1/2W, ±10%	V8	6V tube	R20	res., 270KΩ, 1/2W, ±10%
C9	cap., 500 mfd, 10%	R20	res., 270KΩ, 1/2W, ±10%	V9	6V tube	R21	res., 15KΩ, 1W, ±1%
C10	cap., 2 X 20 mfd-500V	R21	res., 15KΩ, 1W, ±1%	V10	6V tube	R22	res., 3KΩ, 1/2W, ±5%
C11	cap., 2 X 20 mfd-500V	R22	res., 3KΩ, 1/2W, ±5%	V11	6V tube	R23	res., 10Ω, 1W, ±1%
		R23	res., 10Ω, 1W, ±1%	V12	6V tube	R24	res., 10Ω, 1W, ±1%
		R24	res., 10Ω, 1W, ±1%	V13	6V tube	R25	res., 10Ω, 1W, ±1%
		R25	res., 10Ω, 1W, ±1%	V14	6V tube		
				V15	6V tube		
				V16	6V tube		
				V17	6V tube		
				V18	6V tube		
				V19	6V tube		
				V20	6V tube		
				V21	6V tube		
				V22	6V tube		
				V23	6V tube		
				V24	6V tube		
				V25	6V tube		
				V26	6V tube		
				V27	6V tube		
				V28	6V tube		
				V29	6V tube		
				V30	6V tube		
				V31	6V tube		
				V32	6V tube		
				V33	6V tube		
				V34	6V tube		
				V35	6V tube		
				V36	6V tube		
				V37	6V tube		
				V38	6V tube		
				V39	6V tube		
				V40	6V tube		
				V41	6V tube		
				V42	6V tube		
				V43	6V tube		
				V44	6V tube		
				V45	6V tube		
				V46	6V tube		
				V47	6V tube		
				V48	6V tube		
				V49	6V tube		
				V50	6V tube		
				V51	6V tube		
				V52	6V tube		
				V53	6V tube		
				V54	6V tube		
				V55	6V tube		
				V56	6V tube		
				V57	6V tube		
				V58	6V tube		
				V59	6V tube		
				V60	6V tube		
				V61	6V tube		
				V62	6V tube		
				V63	6V tube		
				V64	6V tube		
				V65	6V tube		
				V66	6V tube		
				V67	6V tube		
				V68	6V tube		
				V69	6V tube		
				V70	6V tube		
				V71	6V tube		
				V72	6V tube		
				V73	6V tube		
				V74	6V tube		
				V75	6V tube		
				V76	6V tube		
				V77	6V tube		
				V78	6V tube		
				V79	6V tube		
				V80	6V tube		
				V81	6V tube		
				V82	6V tube		
				V83	6V tube		
				V84	6V tube		
				V85	6V tube		
				V86	6V tube		
				V87	6V tube		
				V88	6V tube		
				V89	6V tube		
				V90	6V tube		
				V91	6V tube		
				V92	6V tube		
				V93	6V tube		
				V94	6V tube		
				V95	6V tube		
				V96	6V tube		
				V97	6V tube		
				V98	6V tube		
				V99	6V tube		
				V100	6V tube		



MODEL HF 60 HIGH FIDELITY 60 WATT AMPLIFIER

Electronic Instrument Co., Inc.
Brooklyn 11, N. Y.

RESISTOR COLOR CODES

RMA COLOR CODE FOR FIXED COMPOSITION RESISTORS

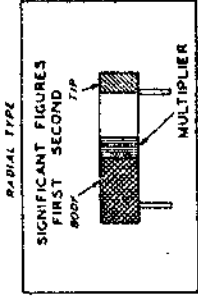
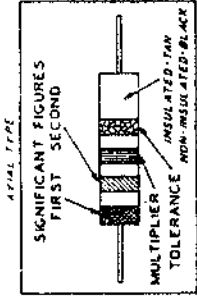

JAN COLOR CODE FOR FIXED COMPOSITION RESISTORS

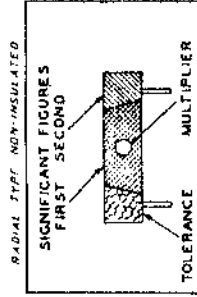
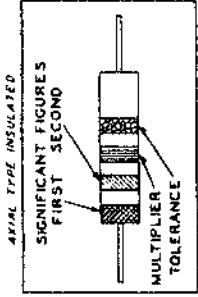

CAPACITOR COLOR CODES

RMA 3-DOT COLOR CODE FOR MICA-DIELECTRIC CAPACITORS

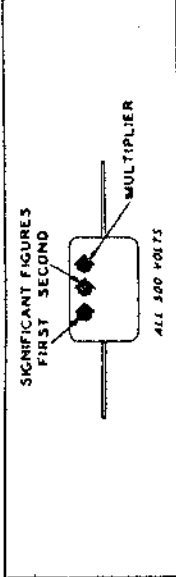

RMA 8-DOT COLOR CODE FOR MICA-DIELECTRIC CAPACITORS

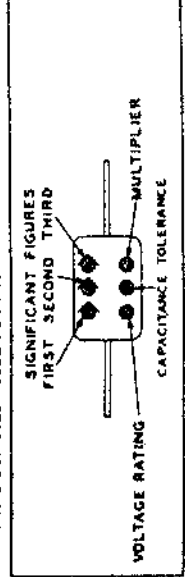

RMA COLOR CODE FOR TUBULAR CERAMIC-DIELECTRIC CAPACITORS

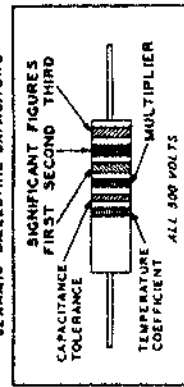

JAN 6-DOT COLOR CODE FOR PAPER-DIELECTRIC CAPACITORS

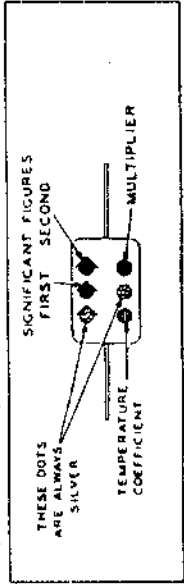

JAN 8-DOT COLOR CODE FOR MICA-DIELECTRIC CAPACITORS

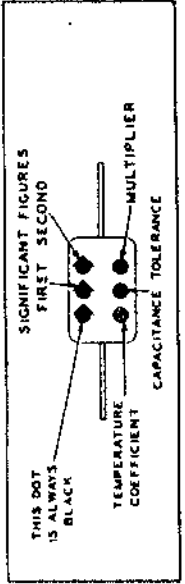

JAN COLOR CODE FOR FIRED CERAMIC-DIELECTRIC CAPACITORS

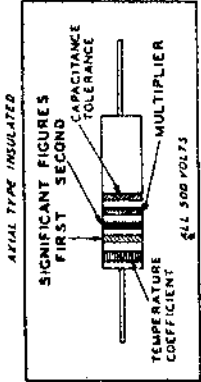

RMA: RADIO MANUFACTURERS ASSOCIATION
JAN: JOINT ARMY-NAVY

RESISTORS		CAPACITORS						
TOLERANCE	MULTIPLIER	SIGNIFICANT FIGURE	COLOR	RMA MICA AND CERAMIC-DIELECTRIC	JAN MICA AND PAPER-DIELECTRIC	JAN CERAMIC DIELECTRIC	VOLTAGE RATING	TEMPERATURE COEFFICIENT
	1	0	BLACK	1	1	1		A
	10	1	BROWN	10	10	10	100	B
	100	2	RED	100	100	100	200	C
	1000	3	ORANGE	1000	1000	1000	300	D
	10000	4	YELLOW	10000	10000		400	E
	100000	5	GREEN	100000	100000		500	F
	1000000	6	BLUE	1000000			600	G
	10000000	7	VIOLET	10000000		0.01	700	
	100000000	8	GRAY	100000000		0.1	800	
	1000000000	9	WHITE	1000000000		0.1	900	
5	0.1		GOLD	0.1	0.1		1000	
10	0.01		SILVER	0.01	0.01		2000	
20			NO COLOR				500	

MODEL HF60 ADDENDA (Book# HF60
HF60-1)

To limit the effect on the HF60 of a preamplifier taking its power from the HF60, the following wiring steps have been changed as shown. An additional step (26), not in the book, has been added for the wiring in of an additional component, 15K Ω resistor R26.

On page 11C:

Step 5 () Fig. 5. Connect a 33K Ω , 1W (orange, orange, orange, gold) 5% resistor, R15, from XV2-2 (C) to TB4-2 (S). Cut leads to 1 1/4".

Step 13 () Fig. 5. Connect a 750 mmt disc capacitor, C8, from TB3-4 (C) to XV3-3 (S).

Step 14 () Fig. 5. Connect a 6" red lead from TB3-4 (S) to J6-8 (C).

Step 26 () Fig. 5. Connect a 15K Ω (brown, green, orange, silver) 10%, 1 watt resistor, R26, from J6-8 (S) to J6-4 (S). Cut both leads to 3/4".

On page 10C:

Move the lead from TB4-2 to TB3-4. Move the lead from J6-4 to J6-8. Draw in a 15K Ω , 1 watt resistor, R26 from J6-4 to J6-8.

On the replacement parts list:

Change component now beginning with 10852, as follows.

10852 R10,26 res., 15K Ω , 1W, \pm 10% (brown, green, orange, silver) 2

On the schematic:

Add resistor R26, 15K Ω , 1W, \pm 10%, to the parts list. Draw this resistor from pin 4 to pin 8 on J6. Remove arrow from 4 at socket J6 and connect pin 8 on J6 to pin 8 on V5. Remove arrow marked "4" between R9 and R10.