

STEREO DUAL POWER AMPLIFIER

MODEL

HF-89



EICO

INSTRUCTION

MANUAL

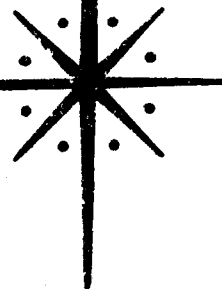

ELECTRONIC INSTRUMENT CO. INC.
3300 NORTHERN BLVD., L. I. CITY 1, N. Y.



MODEL HF 89 STEREO DUAL POWER AMPLIFIER

general description

GENERAL

The very finest techniques known to the audio art are applied in the HF-89 stereo high fidelity dual power amplifier to insure the utmost in audio quality under the most demanding circumstances. The HF-89 can be used with the superb EICO HF85 stereophonic preamplifier or with any good self-powered stereo preamp.

Each power amplifier of the HF-89 is conservatively rated at 50 watts and employs the thoroughly proven cathode-coupled phase inverter-driven circuit, preceded by a direct-coupled voltage amplifier. Ultra linear connected, fixed-biased, push-pull EL34's are used in the output stage and provision is made for both bias and dc balance adjustments. The very low impedance characteristic of silicon diode rectifiers gives the common power supply for the two amplifiers very good regulation. As a result, signal conditions in one amplifier have negligible effect on the operating conditions of the other amplifier -- a very worthwhile feature in a high quality design. To insure long life for the silicon diode rectifiers, electrolytics, and tubes, a surgeistor is included to limit the starting surge currents.

SPECIFICATIONS

Output Power: 100 watts (two 50 watt amplifiers) continuous, 200 watts peak

IM Distortion (60 & 7000 CPS at 4:1): 0.5% at 100 watts

Harmonic Distortion: Less than 0.25% from 30 to 15,000 cps and less than 1% from 20 to 20,000 cps within 1db of 100 watts

Frequency Response: ± 0.5 db 5 cps - 100kc

Rise Time: 2.5usec

Square-Wave Response: Essentially undistorted to 20,000 cps

Inverse Feedback: 18db

Stability Margin: 13 db

Damping Factor: above 12, 20 cps to 20kc

The intrinsic quality of the driving circuit, the output tubes, and the output transformers in the HF-89 is unsurpassed. IM distortion at normal listening levels drops to below 0.1%, and even at 100,000 cps a total of 60 watts undistorted output is available to insure unimpaired transient (square wave) response even at very high power levels. The low end is extremely solid and full, as an undistorted total power output of 78 watts at 15 cps and 28 watts at 10 cps would imply. Furthermore, the high circuit and component quality results in less feedback required to achieve these very low distortion figures, so that the HF-89 amplifiers have a very healthy stability margin to insure perfect results in any application.

The methods of stereo recording are such that, at moments, practically all the sound is in one channel or the other. For this reason, the best stereo installations require an amplifier in each channel as powerful as that used in the best monophonic installations. 50 watt amplifiers have been found very worthwhile in the best monophonic installations and a dual 50 watt amplifier will be found equally worthwhile in the best stereo installations.

Channel Separation: 60db

Sensitivity: 0.55V for full output

Hum: Better than 90db below full output

Controls: Level Ch. 1, Level Ch. 2, "Service Selector" switch, ON-OFF switch

Speaker Connections: 4, 8, and 16 ohms

Tubes: 1-ECC83/12AX7, 2-6SN7GTB, 4-EL34, 2 silicon diode rectifiers (power), 1 selenium rectifier (bias); surgeistor protected for long life

Power Source: 117V, 60 cps

Power Consumption: 215 watts at no signal, 270 watts at 100 watts out

Size: 15" x 11" x 6"

Shipping Weight: 37 1/2 lbs.

mechanical installation

GENERAL

a) **HEAT DISSIPATION (VENTILATION):** In common with other electronic equipment, the Model HF-89 produces a great deal of heat in normal operation. Unless continuous and adequate air flow is obtained around the heat producing elements, these elements will overheat and their useful life will be greatly curtailed. Adequate ventilation will be provided if the amplifier is installed in an open-back console provided that the top of the amplifier is spaced at least two inches below any shelf mounted above it. If the cabinet is enclosed at the rear, provide several large holes or slots as low down and as high up in the cabinet back as possible. As an alternate, holes may be provided in the sides, bottom, or top of the cabinet. The important thing to remember is that effective ventilation requires provision for cool air to enter at the bottom and to leave at the top.

If the amplifier is not installed in a console, it should be situated preferably on an open surface. An attractively finished matching cover for the Model HF-89 is available, which will provide a "finished" appearance as well as protection when the amplifier is not installed in a console. Four rubber feet are also provided so that the amplifier will not mar the surface of furniture on which it is placed.

b) **ACCESSIBILITY TO PARTS:** Tubes are the most frequently replaced items in electronic equipment. If the amplifier is placed in a console, sufficient space should be allotted to reach and remove any tube in the amplifier. Furthermore, input and output terminals of the amplifier should be accessible to permit easy interchanging of system components for comparison. If antennas are strung around the back of the console in which the amplifier is installed, arrange them so they will not interfere.

c) **ELECTRICAL ISOLATION:** To realize the full benefit of having a power amplifier physically separate from the

preamplifier-control unit and/or tuner, the power amplifier should be placed at least one foot away (more if possible) from either or both of these units.

d) **ACOUSTICAL ISOLATION:** If amplifier and speaker are installed in the same cabinet, provide sufficient separation to minimize mechanical speaker vibration reaching the amplifier. The minimum separation is about one foot.

CONSOLE MOUNTING

Having determined a proper location for the amplifier in the particular console, the correct procedure for mounting the amplifier chassis is as follows: a) If the rubber feet have been inserted in the bottom plate, remove them (pry out with a thin screwdriver). b) Remove the 10 screws which fasten the bottom plate to the chassis. c) Place the bottom plate (bumps facing up) at the location on the shelf or the other mounting surface in which it is desired to mount the amplifier. With a sharp pencil, placed with its point directly against the edge of the lower surface of the bottom plate, draw the outline of the bottom plate on the shelf and also mark the position of the two extreme holes on both the long sides (front & rear). d) Remove the bottom plate and drill each of the marked holes on the shelf to a diameter of 1/4". e) Refasten the bottom plate to the chassis, with the six #8 x 3/8 screws previously removed, using the center holes on each of the long sides and the two holes on each of the short sides. f) Replace the chassis on the shelf, positioning it exactly in the outline previously drawn. g) From the bottom side of the shelf, insert a #8 x 1" screw with a 1/2" flat washer against the head through each of the four front and rear holes. These screws engage the stamped nut over each hole on the chassis flange and when tightened secure the chassis to the shelf.

electrical installation

POWER

a) **POWER REQUIREMENTS:** The EICO Model HF-89 requires 215 watts at no signal, 270 watts at 100 watts out.

b) **REMOTE SWITCHING:** The EICO Model HF-89 is provided with its own ON-OFF power switch. If the HF-89 power amplifier is being used with a preamplifier, such as the EICO HF-85, or a self-powered tuner-pre-amplifier, the line cord of the HF-89 is inserted in a switched 117VAC convenience outlet in the control unit.

Turn the power switch on the HF-89 to ON. Note: When using a self-powered preamplifier-control unit, touch one end of a wire to the preamplifier chassis and the other end to the power amplifier chassis. If a spark occurs, pull out the HF-89 line cord plug and re-insert it with the prongs reversed.

c) **CONVENIENCE OUTLETS:** When the HF-89 is used with a preamplifier, such as the EICO HF-85, normally the convenience outlets on the preamplifier will be used.

However, the HF-89 outlets may be used also, if desired, in which case both of them will be "switched".

INTERCONNECTION OF COMPONENTS: SIGNAL

All input connections are to be made using single conductor shielded cable. Unless the source has a low impedance output, such as a cathode follower (with which up to 50 ft. of cable can be used), use the shortest possible connection. In any case, use a low capacity type of shielded cable (as low as 25mmf capacity per foot is available). Both ends of the cable must be fitted with RCA type phono plug connectors. For speaker connections, use plastic covered lamp cord or flat ribbon twin lead.

(1a, 1b, 1c below are possible input connections)

1a) STEREO CONTROL PREAMPLIFIER TO HF-89 DUAL POWER AMPLIFIER: Use two cables as described above. Connect one cable from preamplifier output 1 to input 1 on the HF-89. Connect another from preamplifier output 2 to input 2 on the HF-89. Set the Service Sel switch at the SEPARATE position. Power amplifier can deliver 50 watts per channel. DO NOT use dual conductor shielded lead.

1b) MONAURAL CONTROL PREAMP TO HF-89 DUAL POWER AMPLIFIER: Use one cable as described above. Connect this cable from the preamplifier output to input 2 on the HF-89. Put the Service Sel switch into the COMBINED position. The power amplifiers can deliver a total of 100 watts to the speaker.

1c) USING YOUR OLD AMPLIFIER: You can use your old power amplifier or integrated amplifier for one stereo channel, and the HF-89 connected for parallel operation of the dual amplifiers for the second stereo channel. This may be worthwhile only if your old amplifier has a rated power output of at least 50 watts. Connect one cable from stereo preamp output 1 to input 2 of the HF-89 and set the Service Sel switch at the COMBINED position. With the speaker connection terminals of the dual amplifiers connected in parallel, the HF-89 can deliver 100 watts to the speaker in stereo channel 1. Connect another cable from stereo preamp output 2 to input of your old power amplifier or to the tuner or auxiliary input of your old integrated amplifier. (In the latter case, set the tone controls of the old amplifier to "flat" and loudness contour or filter controls to no effect). The power capability of the second channel will then be the same as that of your old amplifier.

(2a, 2b, 2c, 2d below are possible output connections)

2a) In the situation described in 1a above, for stereo operation connect one speaker system between "G" and

the appropriate impedance tap on the speaker connection terminal board for amplifier 1. Similarly, connect the appropriate impedance tap on the speaker connection board for amplifier 2. If you have only one speaker system at this time, and wish to use the power of both amplifiers combined to drive it, then use the parallel operation connection described in 2d below.

2b) In the situation described in 1b above, if you have two speaker systems connect one to each speaker connection terminal board (one for each amplifier) just as described in 2a above. If you have only one speaker system, use the parallel operation connection described in 2d below.

2c) In the situation described in 1c above, it is implied that you have two speaker systems. Connect one speaker system to your old amplifier and the second speaker system to the HF-89 dual power amplifiers connected in parallel as described in 2d below.

2d) Parallel operation of the HF-89 dual power amplifiers with full 100 watts output is possible for speaker up to 8 ohms impedance: First determine the rated impedance of the speaker system to be connected to the paralleled amplifiers and multiply it by two. Locate the connection terminals on each of the two speaker connection terminal boards on the HF-89 assigned to the tap of this value. Connect an external jumper wire between this particular pair of terminals (16 to 16 for an 8Ω speaker, or 8 to 8 for a 4Ω speaker). Finally, connect the speaker between one of the "G" terminals and one of the pair of terminals connected together by the jumper wire.

CONTROL ADJUSTMENTS

a) The INPUT LEVEL ADJ. controls are intended to protect the speaker system from "blasting" should someone turn the preamplifier-control unit level controls to full. It permits you to attenuate the preamplifier output signal by the desired amount at the input to the power amplifier where it can not be "fiddled" with. Start by setting the INPUT LEVEL control to the maximum counter-clockwise (maximum attenuation) position using a screwdriver. Set the LEVEL control on one channel of the preamplifier at the midpoint of its range of rotation. Turn your phonograph on and play an average orchestral record. Then slowly rotate the appropriate INPUT LEVEL ADJ. control clockwise until the music is at normal (or concert) listening level. Repeat for the second channel. This completes the adjustment.

b) ON-OFF SWITCH: Should be set at the ON position when the unit is used with a preamplifier. It may be used as a power on-off switch when the amplifier is accessible.

BIAS & BALANCE ADJUSTMENTS

In the HF89, fixed bias is employed in the output stages. Each of the two amplifiers is provided with a BIAS ADJ. potentiometer and a BALANCE ADJ. potentiometer. It is essential that these controls be adjusted exactly as instructed before putting a completed kit amplifier into use, or at any time thereafter when any of the output tubes are replaced or it is suspected that a dc unbalance in the output tubes has occurred in the course of use.

In the Final Steps of the Construction section, it is instructed that both BALANCE ADJ. pots R23 and R24, and both BIAS ADJ. pots, R25 and R26, be set to mid-rotation before connecting the unit to the AC line. Be sure this is done. Immediately after the unit is turned on, perform balance and bias adjustments in each amplifier according to the methods and schedule given below.

Instrument Required: VOM or VTVM of at least $\pm 3\%$ accuracy on DC voltage measurement with a lowest DC voltage range not exceeding 3 volts full scale.

a) BALANCE ADJUST METHOD. (Use the BALANCE ADJ. pot and METER jacks for the particular amplifier,

1 or 2, being adjusted.) Set the VOM or VTVM to the lowest DC voltage range and at either the plus or minus DC voltage function. Connect the meter leads to the pair of METER pin jacks for amplifier 1 or amplifier 2 on the rear chassis apron. If the meter deflects to the left of zero, switch the function to the opposite sign or reverse the leads. Adjust the corresponding BALANCE ADJ. control for a zero or minimum reading. This completes the balance adjustment, whereupon the meter leads can be removed from the meter pin jacks.

b) BIAS ADJUST METHOD. (Use the BIAS ADJ. pot and a METER jack of the pair for the particular amplifier, 1 or 2, being adjusted.) Set the VOM or VTVM at the plus DC voltage function and the lowest DC voltage range (not exceeding 3 volts full scale). Insert the "hot" meter lead into either one of the pair of METER pin jacks for the particular amplifier (1 or 2) being adjusted, and connect the common or ground meter lead to either of the speaker connection terminals marked "G" (ground). Set the corresponding BIAS ADJ. control for a meter reading of 0.63 volt. This completes the bias adjustment, whereupon the meter leads can be removed.

BALANCE & BIAS ADJUSTMENT SCHEDULE	
TIME	PROCEDURE
Immediately upon turning amplifier on for the first time. (Either after completing the kit or after replacing output tubes.)	1. Adjust BALANCE amplifier 1 2. Adjust BIAS amplifier 1 3. Adjust BALANCE amplifier 2 4. Adjust BIAS amplifier 2 Repeat steps 1, 2, 3, and 4
15 minutes later	Repeat steps 1, 2, 3, and 4
2 hours later	Repeat steps 1, 2, 3, and 4
2 weeks later	Repeat steps 1, 2, 3, and 4

TROUBLE-SHOOTING PROCEDURES

Your amplifier should require little service except for normal tube replacement. We recommend no substitutions for the tube types used in this amplifier. The EL34 type is distributed nationally by the Amperex Electronic Corporation (230 Duffy Ave., Hicksville, L.I., N.Y.) and Mullard Ltd. (International Electronics Corp., 81 Spring St., N.Y. 12, N.Y.) If necessary, replacements at any time can be obtained directly from EICO.

To facilitate servicing, remedial and trouble-shooting procedures have been provided in the TROUBLE-SHOOTING CHART that follows: A VOLTAGE AND RESIST-

ANCE CHART is also provided as an aid in locating defective components and to permit a careful, stage-by-stage check of the amplifier. DC operating voltages are given both at no signal and at a signal developing 50 watts output per channel as well as the corresponding 1kc signal voltages.

To isolate the source of unusual hum or noise in your system, first turn off the AC power and then unplug the audio cable connecting to the amplifier input. Then turn the AC power on again and note whether hum or noise has decreased. If it has, the fault is in the preamplifier or associated equipment and measures should be taken to correct it as described in the service notes for these units.

GENERAL INSTRUCTIONS

The EICO kit you are about to assemble and wire has been designed to meet the highest standards of performance. It is a high quality instrument, to be constructed from the finest components available anywhere.

The following Construction Manual has been written to carefully guide you through the construction of your kit. If you follow all the instructions implicitly and work carefully without haste, you will be rewarded with many years of fine performance from this instrument and a personal inner satisfaction from a job well done.

Your Construction Book: Beginning with the number on this page, and throughout the rest of your Construction Manual, the page numbers are followed by a "C" (1C, 2C, etc.). The Instruction Manual, detailing the installation, operation and maintenance of your instrument, are identified by numerals only, without any letters following these numerals.

Observe that the Instruction Manual section precedes this page and follows the last page of your Construction Book section. After you are certain that you have successfully completed the wiring of your kit, you no longer need the Construction Book. You may remove these centrally located Construction pages, leaving the Instruction section intact for future reference. Keep the Instruction Manual for information as to the installation and operation, as well as for any maintenance that may be necessary in the future, on your amplifier.

Choosing a Workbench and Tools: To avoid the accidental loss or misplacement of components, choose a convenient workbench before unpacking your new kit. You will find it most advantageous to choose a corner on a table that will not be used for any other purpose until you have completed the construction of your kit. Proper precautions should be observed to prevent damage to any table top from a soldering iron or any heavy tools.

When you check the component parts against the Parts List later on, it will be convenient to separate the various pieces into types of components and hardware sizes. It will be convenient to keep these sorted pieces separated in the compartments of specially made trays. Small cartons, egg trays or a refrigerator ice tray with dividers serve equally well.

Several basic tools are required to constructing this kit. They are:

1. Screwdriver - 3/16" to 1/4" blade
2. Screwdriver - 1/8" blade
3. Longnose pliers - 5" or 6"
4. Diagonal wire cutters
5. Soldering Iron (100 watts), solder gun or pencil iron (35 watts).
6. Gas Pliers
7. High quality rosin core radio solder. DO NOT use Acid Core solder or Paste fluxes under any circumstances.

The following tools are useful, but are not absolutely necessary to construct this kit:

1. Socket wrench set
2. Open end wrench set
3. Wire Stripper

Unpacking the kit: This procedure serves two purposes. First, it lets you get acquainted with the various types of components. Second, you check to ascertain if you received all the parts required to build the kit. This is your opportunity to have any packing errors corrected.

When unpacking, handle all parts carefully so that you will not damage any fragile components. Do not throw any packing material away until after having checked all components. Check each part off against the "Parts List" which you will find in your Instruction Book. Check the packing for any small parts.

From time to time, due to modernization or possible error, corrections may be necessary to your Parts List. If there are any changes to be made, they will be listed on the loose "addenda sheets" included with this book. Make these corrections, if any, before checking your components. If no corrections to your Parts List are noted on the addenda sheets, or there are no addenda sheets, assume your Parts List is correct, and commence to check all components against this list.

To enable rapid identification of electronic parts, each part has been assigned one or two letters of the alphabet called a reference designation. These reference designations are nothing more than an initial letter or two representing the name of the part. For example, a vacuum tube has been assigned the reference designation letter V, and a transformer the letter T. Thus, if you have seven vacuum tubes and three transformers in your kit, these parts would be identified by the designation V1 through V7 and T1 through T3, respectively. The reference designation assigned to receptacles (often referred to as jacks) is the letter J. The different types of jacks and plugs used in this kit are so lettered and illustrated in the construction steps. In some cases, two jacks are mounted on one bakelite strip and are so noted.

Capacitors have symbol numbers starting with a C.

Some capacitors, such as electrolytics, are marked with a + and a -. These are the only capacitors that must be mounted in a specific direction. Follow the direction for mounting described in the appropriate steps below. When no direction is mentioned, mount the capacitor either way. Some molded or paper capacitors have a black line near one end. Although these can be mounted without any concern for direction, it is preferable that you follow the direction for the black line shown on the drawing. If there is no black line on the drawing or on the capacitor, just mount the capacitor in either direction.

Ceramic capacitor tolerance may be noted by a letter rather than a number. A "K" indicates 10%. An "M" indicates 20% and a "P" indicates a GMV.

Resistors are denoted by the symbol letter R.

Some resistors have their resistance value stamped on the surface of the resistor body. However, other fixed resistors are coded with color marking which indicate their value. The actual color code of these resistors is noted in the parts list. In some instances, even when the color code is noted, in the book, the actual resistor value may be stamped on the body, rather than the color code.

The tolerance of a resistor is the amount the resistance value can vary around its marked value. Thus, if a 1K (1000 Ω) resistor has a $\pm 10\%$ tolerance, its actual value can be between 900 ohms and 1.1K ohms. If the same resistor has a $\pm 5\%$ tolerance, its actual value can be between 950 ohms and 1.05K ohms. The fourth color band from the end of the resistor, indicates the tolerance. The gold band indicates a 5% tolerance, the silver band a 10% tolerance and the absence of a band a 20% tolerance. This tolerance value is always stated or given as part of the color code when the resistor is listed. If the resistor is marked with a number rather than a color code, the tolerance, is stamped on the body. In your kit, 5% resistors may be substituted for 10% and 10% resistors substituted for 20%. However, be certain that you do not use a 10% resistor when a 5% resistor is required or a 20% resistor when a 10% or 5% resistor is specified.

Silicon rectifiers are efficient diodes replacing rectifier tubes. One end is the cathode (+). On the second end is the anode (-). The various possible shapes of rectifiers used are illustrated. The cathode and anode ends are designated in the drawing.

SILICON RECTIFIERS



The various types of terminal strips are assigned the designation letters TB. The types used in this kit are illustrated and denoted in this figure.

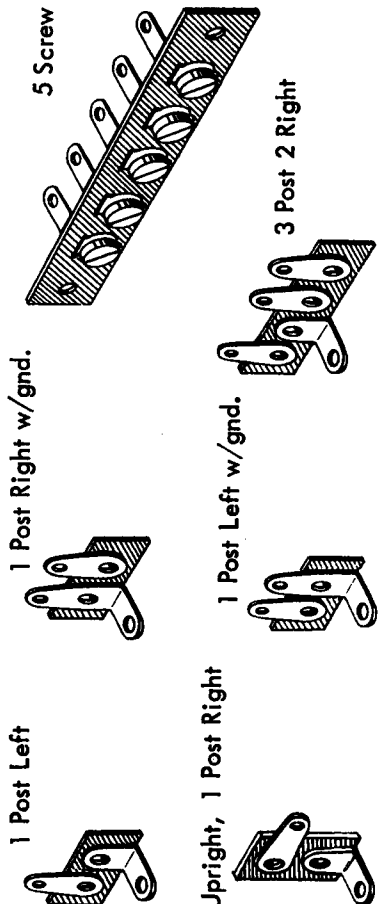

A device used to protect the components from overload on initial voltages surges is called a surgistor and designated by SR.

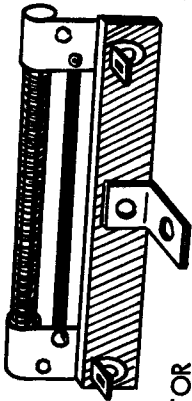

SURGIStOR

Hardware is a general term for mechanical parts used in the assembly of EICO kits. Such items are usually screws, nuts and washers. Machine screws are sized in accordance with the diameters of the threaded portion (#4, #6, #8, #10) with the smaller number denoting the smaller diameter. The second number indicates the number of threads to an inch. Thus, a #6-32 screw has a #6 diameter with 32 threads per inch. The final number indicates the length of the threaded portion. A #6-32 x 3/8 has a 3/8" long threaded portion. The diameters are shown in the figure.

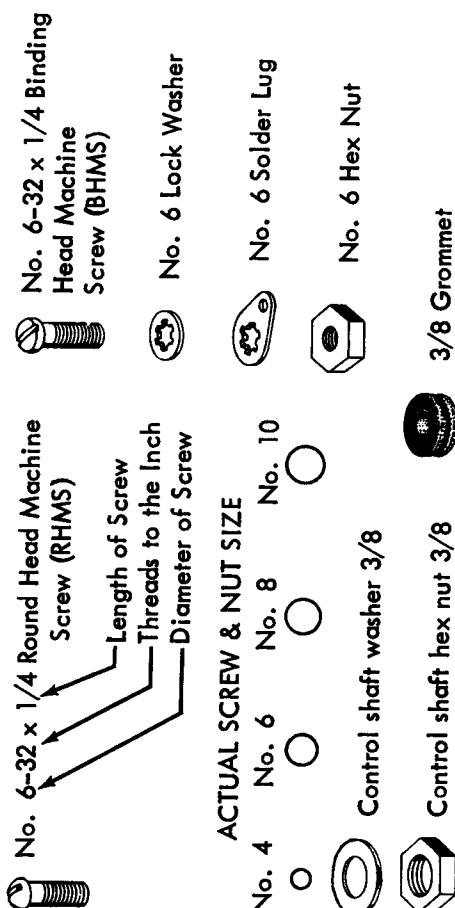

The figure also shows the various head types in which these screws are supplied. Use the type specified in the particular step. Washers and nuts are sized in accordance with the diameter of the screws they are used with. Tinnerman speed nuts are generally used to mount the bottom plate.

Various types of washers are supplied. A lockwasher has internal or external teeth. A flat washer is made out of thin metal. Grommets are rubber devices used for insulating wire from the metal chassis. Most of the other component parts used with the kit are self evident and require little further explanation or description.

If after having checked all your components against the parts list, you find a shortage, please write us at

Customer Service
Electronic Instrument Co., Inc.
33-00 Northern Blvd.
Long Island City 1, N. Y.

Include the inspection slip with your letter describing the shortage. If there is any slight hardware shortage, you can expedite matters by purchasing these pieces at your local jobber or hardware store.

Soldering Techniques: To get a good, clean connection, use the soldering techniques described below. USE THE BEST GRADE OF ROSIN CORE RADIO SOLDER ONLY. UNDER NO CIRCUMSTANCES SHOULD ACID CORE SOLDER OR FLUX BE USED. The use of acid core solder or paste fluxes can cause serious corrosion and will void all the repair and service guarantees.

The soldering and wiring techniques described below should be practiced several times by the novice before he attempts to wire or solder components in the actual kit. Practice several connections with a spare piece of wire and a socket or terminal strip you can purchase at your local jobber.

First make a good mechanical connection. Remove 1/4" of insulation from the end of the wire. Feed the wire through the solder lug opening so that the wire insulation just touches the lug. With the long-nose pliers, bend the wire lead around the lug and crimp the wire lead to the lug. Now solder this wire. Place the tip of the hot soldering iron on the lug or terminal at a point close to the wire being soldered. Apply the solder to the junction of the lug, wire and soldering iron. When the lug and wire have been heated to the correct temperature, the solder will flow into and over the joint. Remove the iron when the solder starts to flow and remove the solder immediately after. Use only enough solder to cover the wire at the connection point.

A poor solder connection is obvious by its appearance. A grainy or pitted joint is a poor connection due to insufficient heat. Blobs of solder on the wire or solder lug is also due to insufficient heat. Solder should flow as a result of the heated lug and wire. Do not solder by applying solder to the iron tip and then wiping the hot solder onto the joint. A well soldered joint is indicated by a smooth bright finish on the soldered connection.

Construction Hints: The various lengths of wire to be used in the kit are specified in the construction steps. After cutting the wire to the length specified, strip the insulation off 1/4" from each end. The exposed wire will be used to make the actual connection to the solder lug.

Shield wire sizes are also indicated in the specific construction step. In the particular step you will be told just how much of the outer insulation must be removed and just how long the shield strands and inner conductor(s) must be. Components, such as resistors, capacitors, transformers, etc., may have longer leads than specified. Cut the leads to the length indicated in the particular construction step. This length is to be measured from the body of the component. In the case of insulated leads, strip 1/4" of insulation off from the ends and twist the strands (if any) of the wire together.

As an example, one step may specify that each lead on a resistor be cut to 1/2". 1/4" of each lead is used to make a mechanical connection to the solder lug. The other 1/4" is between the socket and the component so that the component will not be overheated when soldering.

When a connection is indicated, a(C) or an(S) will appear next to the lug involved. The(C) indicates that the connection should be made mechanically, but is not to be soldered yet, since other leads are to be connected to this same lug. The(S) indicates that the connection should be made and soldered immediately. However, the(S) is always followed by a number, such as(S1), (S2), (S3), etc. This number indicates the number of connections made to the lug. It is a check on the accuracy of your work.

As an example, if it says(S3), you should count three leads going to the lug to be soldered. If there are less than three leads at this particular lug, you will know that you have forgotten one or more leads, or connected them to the wrong lugs. If there are more than three leads, you can be certain you have connected an extra wire to this lug, which should probably go elsewhere.

When you assemble the components in your unit, mark the symbol number of each socket and terminal strip near the part with a crayon. This will facilitate your wiring operation.

When wiring, lay the component in, close to the chassis, dressed as shown in the drawing. Be careful to avoid shorts at the lugs. The book is written so that the wiring closest to the chassis usually gets wired in first. The next layer of wires are to be soldered in next. In each case, dress the leads and components as close to the chassis as possible.

Next to each step number you will find a parenthesis (). After you have completed each step, make a check mark in the parenthesis so that you will have a record of your work. Follow the steps in the sequence written in the book. Do not skip steps or pages.

If any addendos are included in your book to modernize your instrument or make corrections or part substitutions, be sure to correct the Construction Book first before you start to wire or assemble your kit.

You are now ready to construct your fine stereo dual power amplifier.

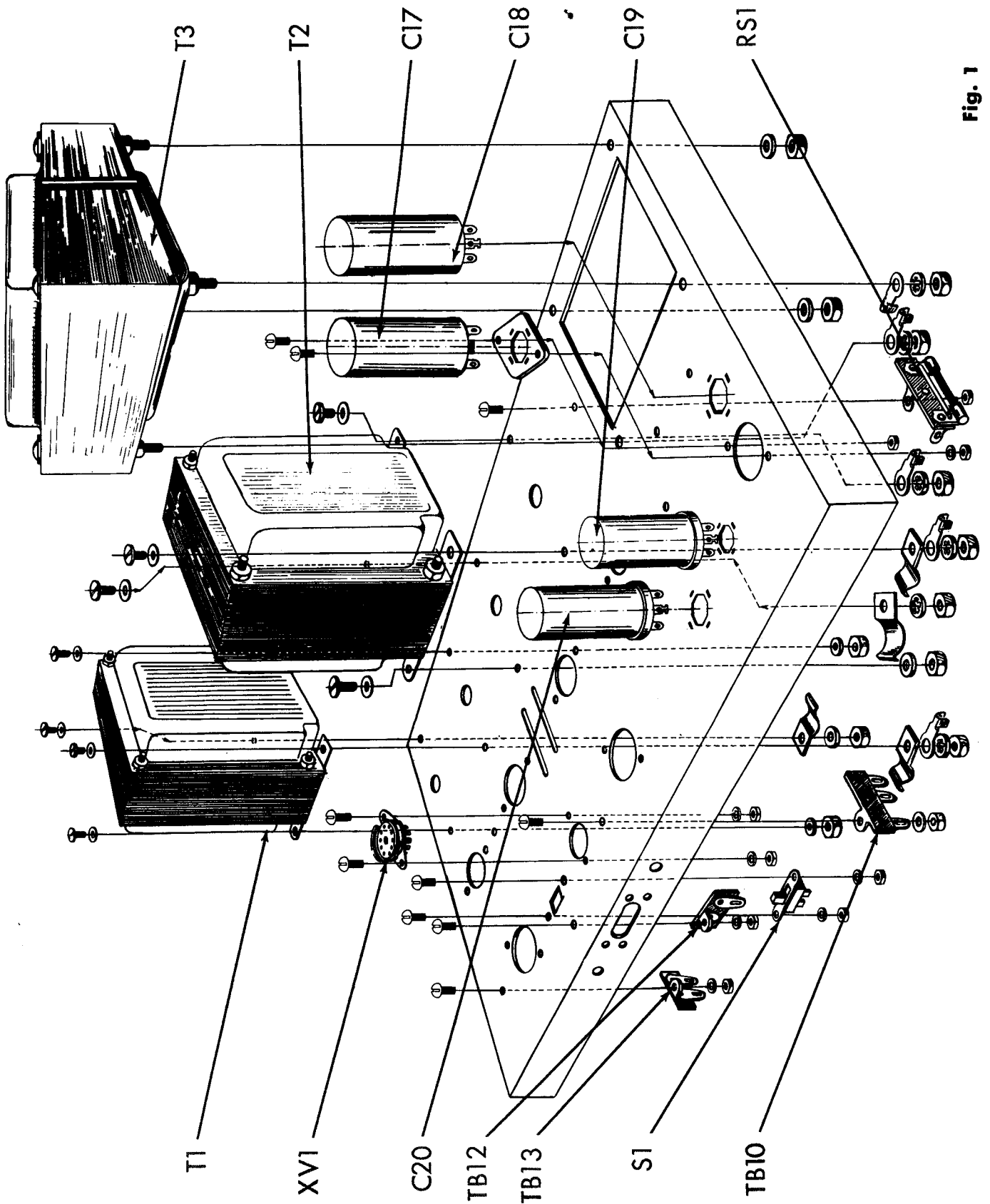

Fig. 1



TOP OF CHASSIS ASSEMBLY

with ground terminal strip, TB13, as shown. Orient these terminal strips as shown in figure 3. Use one #6-32 screw, one #6 lockwasher and one #6 hex nut to secure each terminal strip to the chassis.

- () 1. Fig. 1. On power transformer T3, cut both green leads to 6", one red lead to 6", the other red lead to 7", the white lead to 3", one black lead to 2", the other black lead to 4", one blue lead to 4" and the second blue lead to 6 1/2". On each of these leads strip the insulation back 1/4". Mount the transformer as shown with the green leads toward the center of the chassis and the black leads close to the side of the chassis. Use four #8 lockwashers and four #8-32 hex nuts to secure the transformer to the chassis. Under each of two of the lockwashers, mount a #8 ground lug, as shown in Figure 3.
- () 2. Fig. 1. On both output transformers T1 and T2, cut the black lead to 4", the white lead to 4 1/2", the green lead to 5" and the yellow lead to 5 1/2". Cut the blue and blue-yel. leads to 4 1/2" and the brown and brown-yel. to 5 1/2" and the red and red-yellow leads to 6". Strip the insulation back 1/4" from the ends of each of the leads. Mount transformer T2 with black, brown, green, and yellow leads going through hole "Y" and all the remaining leads going through hole "Z". Secure the transformer to the chassis using four #10-32 screws and four #10 flat washers from above the chassis and four #10 lockwashers and four #10-32 hex nuts from below the chassis. Noting the orientation in figure 3, under one of the lockwashers used in the mounting of T2, place cable clamp #1 and the #10 ground lug "F". Run the leads from hole "Z" under this cable clamp #1. Under a second lockwasher used in the mounting of T2, place cable clamp #4. Run the leads from hole "Y" under this cable clamp #4. Mount ground lug "C" under one of the remaining lockwashers used for the mounting of T2 as indicated in the figure.
- Mount transformer T1 with the black, white, green and yellow leads going through hole "W" and the remaining leads going through hole "X". Secure the transformer to the chassis using four #10-32 screws and four #10 flat washers from above the chassis and four #10 lockwashers and four #10-32 hex nuts from below the chassis. Noting the orientation in figure 3, under one of the lockwashers used in the mounting of T1, place cable clamp #2 and the #10 ground lug "G". Run the leads from hole "X" under this cable clamp #2. Under a second lockwasher used in the mounting of T3, place cable clamp #3. Run the leads from hole "W" under this cable clamp #3.
- () 3. Fig. 1. Mount the single pole double throw slide switch S1, from below the chassis, as shown. See figure #3 for orientation. Use two #6-32 screws, two #6 lockwashers and two #6-32 hex nuts.
- () 4. Fig. 1. From below the chassis, mount the 3 post 2 right terminal strip, TB10; the one post left terminal strip, TB12; and the one post left with ground terminal strip, TB13, as shown. Orient these terminal strips as shown in figure 3. Use one #6-32 screw, one #6 lockwasher and one #6 hex nut to secure each terminal strip to the chassis.
- () 5. Fig. 1. Mount the 9 pin miniature socket with shield support XV1, from above the chassis, as shown. Use two #4-40 screws, two #4 lockwashers and two #4-40 hex nuts. Note the orientation of this socket in figure #3.
- () 6. Fig. 1. Mount the bakelite capacitor mounting plate for C17 from above the chassis, as shown. Use two #6-32 screws, two #6 lockwashers and two #6-32 hex nuts.
- () 7. Fig. 1. Into the slots in the bakelite capacitor mounting plate (mounted in step #6) insert the tabs from the 300ufd, 300V electrolytic can capacitor, C17. Note the orientation of this capacitor in figure #3. Twist the tabs somewhat less than a quarter turn. Do not twist the tabs excessively or they will shear off. Take precautions so that the tabs used to secure the capacitor to the bakelite will not short against the surrounding metal chassis.
- () 8. Fig. 1. Mount the 300mf 300 volt electrolytic capacitor C18, as shown. Note the orientation in Figure #3. Insert the capacitor mounting tabs into the slots in the chassis and twist the tabs a little less than a quarter turn. Do not twist the tabs excessively or they will shear off. Solder the capacitor tab without a hole to the chassis at the slot in the chassis.
- () 9. Fig. 1. Mount the 80mf 500 volt electrolytic capacitor C19, as shown. Note the orientation in figure #3. Insert the capacitor mounting tabs into the slots in the chassis and twist the tabs a little less than a quarter turn. Do not twist the tabs excessively or they will shear off. Solder the capacitor tab without a hole, to the chassis at the slot in the chassis.
- () 10. Fig. 1. Mount the 40-20mfd/500 volt electrolytic capacitor C20, as shown. Note the orientation of the capacitor (half-moon and triangle) in figure #3. Insert the capacitor mounting tabs into the slots in the chassis and twist the tabs a little less than a quarter turn. Do not twist the tabs excessively or they will shear off. Solder the capacitor tabs without a hole to the chassis at the slot in the chassis.
- () 11. Fig. 1. Mount the surgistor RS-1, as shown. Use one #6-32 screw, one #6 lockwasher and one #6 hex nut to secure this component to the chassis. Note the orientation in figure #3.

⊕

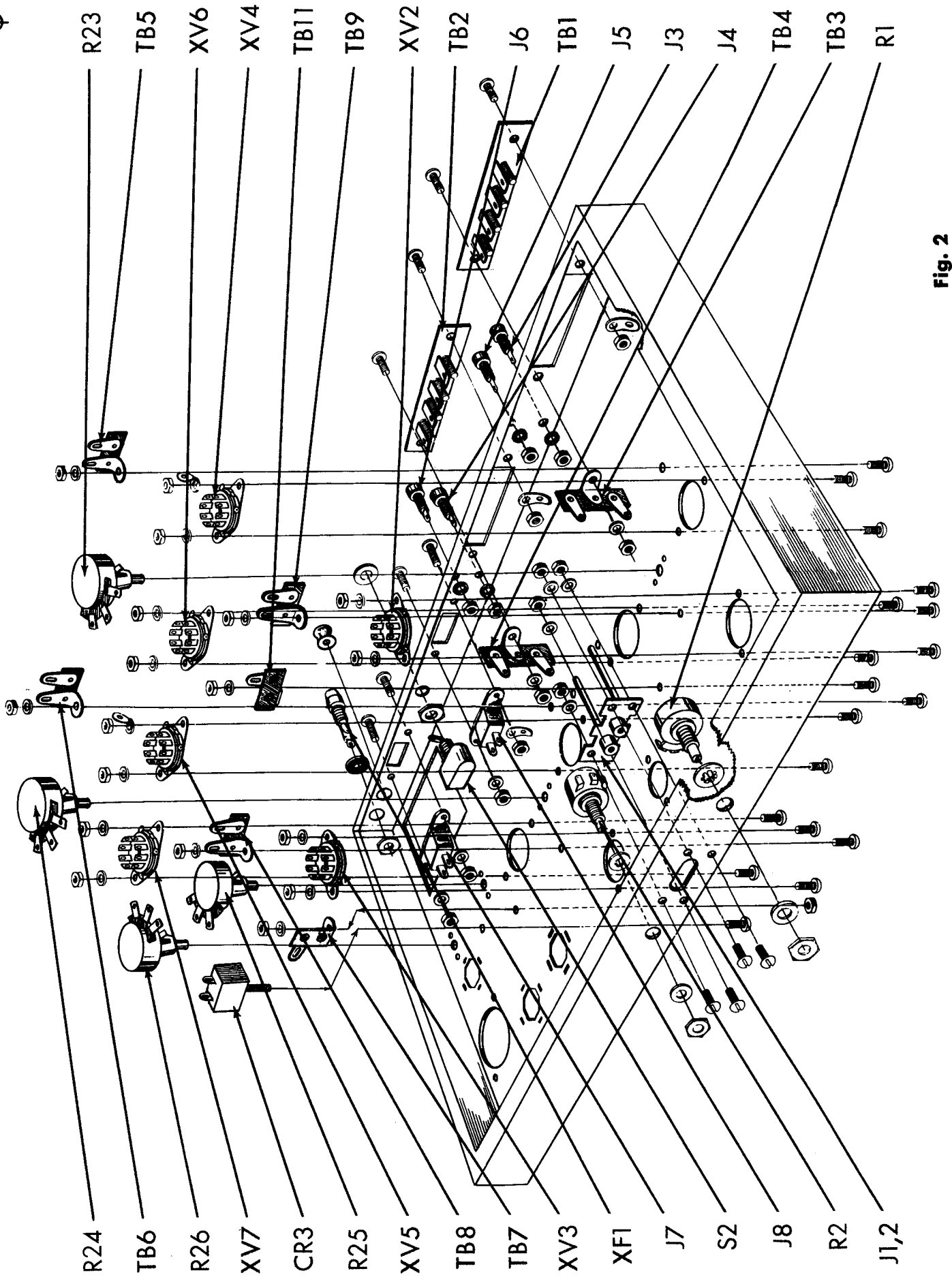

Fig. 2

⊕

BELOW CHASSIS ASSEMBLY

- () 6. Fig. 2. Push a rubber grommet in the remaining hole in the rear apron of the chassis next to the fuseholder.
- () 7. Fig. 2. Mount the four 1 post right with ground terminal strips, TB5, TB6, TB8 and TB9; the 1 post upright right terminal strip, TB7; and the 1 post left terminal strip, TB11, as shown. Note the orientation of each of these terminal strips in figure #3. Use one #6-32 screw, one #6 lockwasher and one #6-32 hex nut to secure each terminal strip to the chassis.
- () 8. Fig. 2. Mount octal sockets XV2, XV3, XV4, XV5, XV6, and XV7 as shown. Note the orientation in figure #3. The number of each pin is indicated next to the pin on the bakelite portion of the socket. Use two #6-32 screws, two #6 lockwashers, and two #6-32 hex nuts to secure each socket to the chassis.
- () 9. Fig. 2. Mount the dual input jack, J1, 2, as shown. Use four #4-40 screws, four #4 lockwashers, and four #4-40 hex nuts.
- () 10. Fig. 2. Mount selenium rectifier CR3, as shown. Note the orientation (+terminal) in figure #3. Secure to the chassis with one #6 lockwasher and one #6-32 hex nut.
- () 11. Fig. 2. Mount potentiometers, R1 and R2, as shown. Use one 3/8 lockwasher inside the chassis and one 3/8 flatwasher and a 3/8 hex nut outside the chassis to secure each potentiometer to the front apron of the chassis.
- () 12. Fig. 2. Mount the two 10K pots, R25 and R26 in the holes near power transformer T1, as shown. Note the orientation in figure #3. Press each pot firmly towards the chassis until a click is heard and is held firmly to the chassis.
- () 13. Fig. 2. Similar to the above, mount the two 50K pots, R23 and R24. Note the orientation and location in figure #3. Press each pot firmly towards the chassis until a click is heard and is held firmly to the chassis.

- () 1. Fig. 2. On the rear apron of the chassis, mount the four screw terminal boards, TB1 and TB2, as shown. Use two #6-32 screws and two #6-32 hex nuts on each. Under one of the hex nuts, used for mounting each terminal board, mount a #6 ground lug. Under each of the remaining hex nuts used for securing the terminal boards TB1 and TB2 to the chassis, mount a 2 post terminal strip and a #6 lockwasher. Mount terminal strip TB3 under the lockwasher and hex nut used for securing TB1 to the chassis and terminal strip TB4 under the hex nut and lockwasher used for securing TB2 to the chassis.
- () 2. Fig. 2. Mount the two convenience outlets, J7 and J8, as shown. Use two #6-32 screws, two #6 lockwashers, and two #6-32 hex nuts on J7. Use two #6-32 screws, one #6 lockwasher, one #6 ground lug and two #6-32 hex nuts on J8.
- () 3. Fig. 2. Mount a 15/32-32 hex nut on the toggle switch S2. Adjust the nut so that only 1/16" of the screw threads are visible on the outside of the chassis when S2 is mounted. Secure the switch with a 15/32-32 ring nut. Tighten in position so that switch will not rotate.
- () 4. Fig. 2. Mount fuseholder XF1, as shown. Use a thin rubber washer outside the chassis. Use a 1/2"-32 hex nut so secure the fuseholder to the chassis. Do not tighten too much or the holder will crack.
- () 5. Fig. 2. Mount the four meter pin jacks, J3, J4, J5 and J6 with the hardware supplied on the jacks. Remove the nut and the fibre washer from the threaded portion of each jack. Pass the threaded portion of each jack through their respective holes in the rear apron of the chassis. Secure each jack with its fibre washer and hex nut inside of the chassis. The small shoulder on the fibre washers should seat in the mounting holes. If the assembly is properly completed, each jack will be insulated from the chassis.

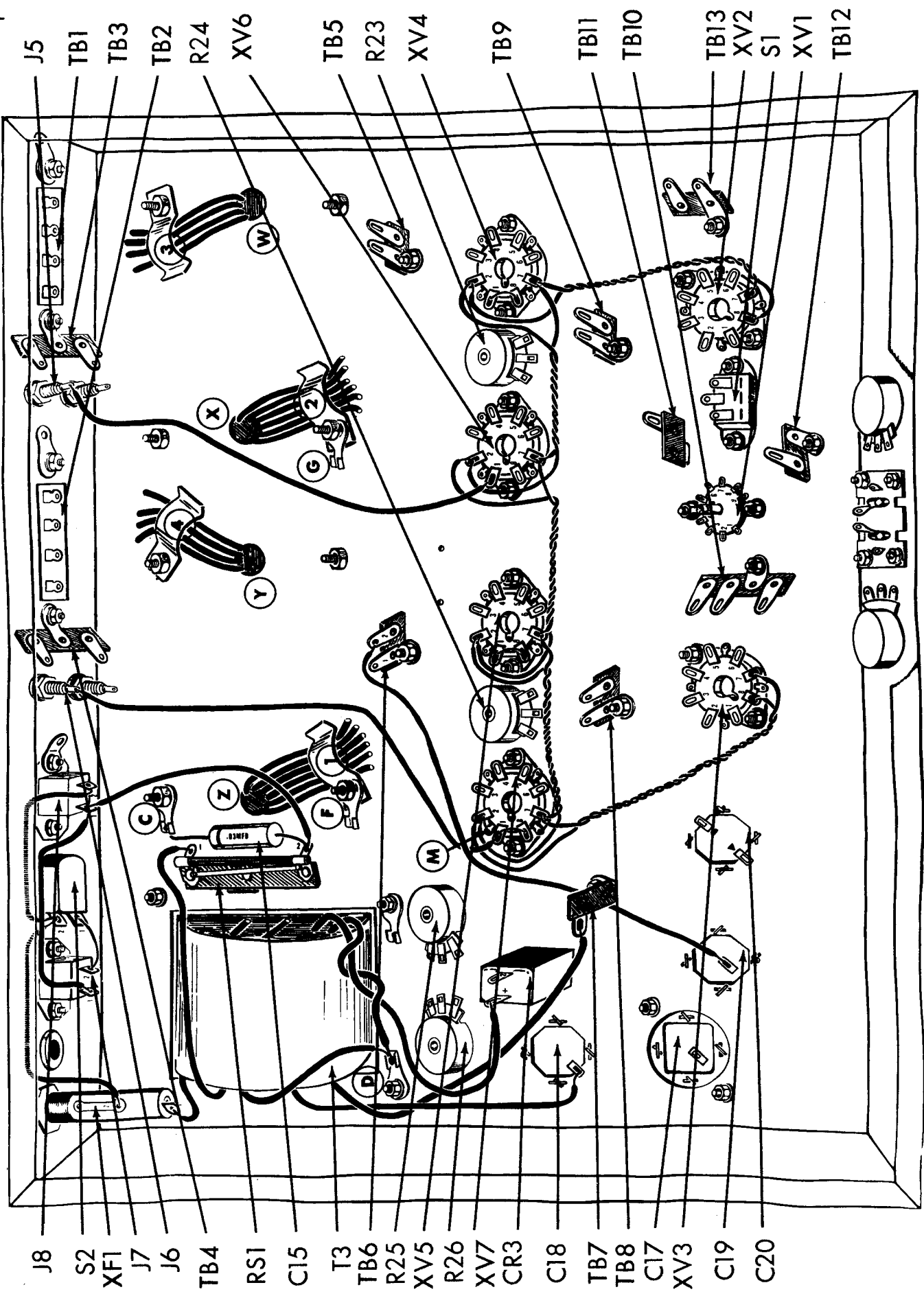

Fig. 3



WIRING

- () 1. Fig. 3. Connect an 8 1/2" piece of red wire from C19 (C) to TB6-2 (C). Run this lead along the chassis as shown.
- () 2. Fig. 3. From power transformer, T3, connect the white lead to ground lug "D" (C), the short black lead to XF1-1 (C) and the longer black lead to RS1-1 (C). Twist the two red leads together as shown. Connect one red lead to C18 (C) and the second red lead to TB7 (C). Twist the two blue leads together. Connect one blue lead to ground lug "D" (S2) and the second blue lead to CR3-1 (S1). Do not use excessive heat when soldering to CR3.
- () 3. Fig. 3. Connect a 4 1/2" piece of grey wire from XF1-2 (S1) to S2-2 (C).
- () 4. Fig. 3. Connect a 4" piece of gray wire from S2-2 (S2) to J8-2 (S1).
- () 5. Fig. 3. Connect a 1 1/4" piece of bare wire from J7-2 (C) to S2-1 (S1).
- () 6. Fig. 3. Connect a 5" piece of gray wire from J7-1 (C) to J8-1 (C).
- () 7. Fig. 3. Connect a 4" piece of grey wire from J8-1 (S2) to RS1-2 (C).
- () 8. Fig. 3. Cut both leads on a .03mfd (orange, black, orange, black, blue) molded capacitor C15 to 1". Connect one lead to RS1-2 (S2) and the second lead to ground lug "C" (S1).
- () 9. Fig. 3. Connect one end of a six inch piece of yellow wire to XV4-2 (C) and one end of a 5" piece of brown wire to XV4-7 (C). Twist the two leads together and run them along the chassis as shown. Connect the other end of the yellow wire to XV2-7 (S1) and the other end of the brown wire to XV2-8 (S1).
- () 10. Fig. 3. Connect one end of a 7" piece of yellow wire to XV4-2 (S2) and one end of a 4" piece of brown wire to XV4-7 (S2). Twist the two leads together and run them along the chassis as shown. Connect the remaining end of the yellow wire to XV6-2 (C) and the other end of the brown wire to XV6-7 (C).
- () 11. Fig. 3. Connect one side of a 7" piece of yellow wire to XV6-2 (S2) and one side of a 4" piece of brown wire to XV6-7 (S2). Twist the leads together and run them along the chassis as shown. Connect the other end of the yellow wire to XV5-2 (C) and the other end of the brown wire to XV5-7 (C).
- () 12. Fig. 3. Connect one end of a 7" piece of yellow wire to XV5-2 (S2) and one end of a 4" piece of brown wire to XV5-7 (S2). Twist the two leads together and run them along the chassis as shown. Connect the other end of the yellow wire to XV7-2 (C) and the other end of the brown wire to XV7-7 (C).
- () 13. Fig. 3. Connect one end of an 8" piece of yellow wire to XV7-2 (C) and one end of a 7" piece of brown wire to XV7-7 (C). Twist the two leads together and run them along the chassis as shown. Connect the other end of the brown wire to XV3-8 (S1) and the other end of the yellow wire to XV3-7 (S1).
- () 14. Fig. 3. Connect a 3/4" piece of bare wire from XV7-2 (C) to ground lug "M" (S1) at XV7.
- () 15. Fig. 3. Connect a 3/4" piece of bare wire from XV7-1 (C) to XV7-8 (S1).
- () 16. Fig. 3. Connect a 3/4" piece of bare wire from XV5-1 (C) to XV5-8 (S1).
- () 17. Fig. 3. Connect a 3/4" piece of bare wire from XV6-1 (C) to XV6-8 (S1).
- () 18. Fig. 3. Connect a 3/4" piece of bare wire from XV4-1 (C) to XV4-8 (S1).
- () 19. Fig. 3. Connect an 8" piece of orange wire from XV7-1 (S2) to J6 (C).
- () 20. Fig. 3. Connect a 7" piece of orange wire from XV6-1 (C) to J5 (S1).

- () 1. Fig. 4. Connect an 7" piece of yellow wire from XV5-1 (C) to J4 (S1).
- () 2. Fig. 4. Connect an 7" piece of yellow wire from XV4-1 (C) to J3 (S1).
- () 3. Fig. 4. From power transformer T3 twist the two green leads together. Run them along the chassis as shown. Connect the shorter green lead to XV7-2 (S4) and the other green lead to XV7-7 (S3). Dress the green leads away from RS1 so that the spring contact has free action.
- () 4. Fig. 4. Connect a 1 1/2" piece of bare wire from TB2-4 (C) to ground lug "A" (S1).
- () 5. Fig. 4. Connect a 1 1/2" piece of bare wire from TB1-4 (C) to ground lug "B" (S1).
- () 6. Fig. 4. From hole "W", the leads have been run under cable clamp #3. Connect the black lead to TB1-4 (S2), the white lead to TB1-3 (C), the green lead to TB1-2 (S1) and the yellow lead to TB1-1 (C).
- () 7. Fig. 4. From hole "Y", the leads have been run under cable clamp #4. Connect the black lead to TB2-4 (S2), the white lead to TB2-3 (C), the green lead to TB2-2 (S1) and the yellow lead to TB2-1 (C).
- () 8. Fig. 4. Connect a 7" piece of red wire from TB6-2 (C) to TB5-2 (C).
- () 9. Fig. 4. The leads from hole "Z" have been run under cable clamp #1. Run the leads from cable clamp #1 as shown. Connect the red and red-yellow leads to TB6-2 (C), the brown lead to XV5-3 (C), the brown-yellow lead to XV5-4 (S1), the blue lead to XV7-3 (S1) and the blue-yellow lead to XV7-4 (S1).
- () 10. Fig. 4. The leads from hole "X" have been run under cable clamp #2. Run these leads from cable clamp #2 along the chassis as shown. Connect the red and red-yellow leads to TB6-2 (C), the brown-yellow lead to XV4-4 (S1), the brown lead to XV4-3 (C), the blue lead to XV6-3 (S1) and the blue-yellow lead to XV6-4 (S1).
- () 11. Fig. 4. Cut all leads on four 3K (orange, black, red, gold) 5% resistors, R39, R40, R41 and R42, to 3/4". Connect R39 from TB3-1 (C) to TB3-2 (C). Connect R40 from TB4-1 (C) to TB4-2 (C). Connect R41 from TB1-1 (C) to TB3-2 (C). Connect R42 from TB2-1 (C) to TB4-2 (C).
- () 12. Fig. 4. Cut all leads on two 225mmf disc capacitors, C11 and C12 to 3/4". Connect C11 from TB1-1 (S3) to TB3-1 (C). Connect C12 from TB2-1 (S3) to TB4-1 (C).
- () 13. Fig. 4. Cut all leads on two 500mmf disc capacitors, C13 and C14, to 1". Cover each lead with a 3/4" piece of spaghetti. Connect C13 from TB1-3 (S2) to TB3-2 (S3). Connect C14 from TB2-3 (S2) to TB4-2 (S3).
- () 14. Fig. 4. Connect an 11" piece of gray wire from TB3-1 (S3) to TB12 (C).
- () 15. Fig. 4. Connect an 10" piece of gray wire from TB4-1 (S3) to TB10-2 (C).
- () 16. Fig. 4. Cut all leads on two 750mmf disc capacitors, C21 and C22 to 1". Connect C21 from TB5-2 (S2) to XV4-3 (S2). Connect C22 from TB6-2 (S7) to XV5-3 (S2).
- () 17. Fig. 4. Connect an 11 1/2" piece of orange wire from R25-2 (S1) to R23-2 (C).
- () 18. Fig. 4. Connect a 5 1/2" piece of orange wire from R26-2 (S1) to R24-2 (C).
- () 19. Fig. 4. Connect a 4" piece of green wire from XV3-4 (C) to XV1-1 (S1).
- () 20. Fig. 4. Cut all leads on six 1K (brown, black, red, silver) resistors R7, R8, R31, R32, R33 and R34 to 1/2". Connect R7 from TB12 (C) to XV1-8 (C). Connect R8 from TB10-2 (C) to XV1-3 (C). Connect R32 from XV5-5 (S1) to XV5-6 (C). Connect R34 from XV7-5 (S1) to XV7-6 (C), R33 from XV6-5 (S1) to XV6-6 (C) and R31 from XV4-5 (S1) to XV4-6 (C).
- () 21. Fig. 4. Cut all leads on two 180K (brown, grey, yellow, silver) resistors R21 and R22, to 3/4". Connect R21 from XV6-6 (C) to R23-1 (C). Connect R22 from XV7-6 (C) to R24-1 (C).
- () 22. Fig. 4. Cut all leads on two 180K (brown, grey, yellow, silver) resistors, R19 and R20 to 1". Cover each lead with a 3/4" piece of spaghetti. Connect R19 from XV4-6 (C) to R23-1 (C). Connect R20 from XV5-6 (C) to R24-3 (C).
- () 23. Fig. 4. Connect a 5" piece of orange wire from C20-B (C) to TB8-2 (C).

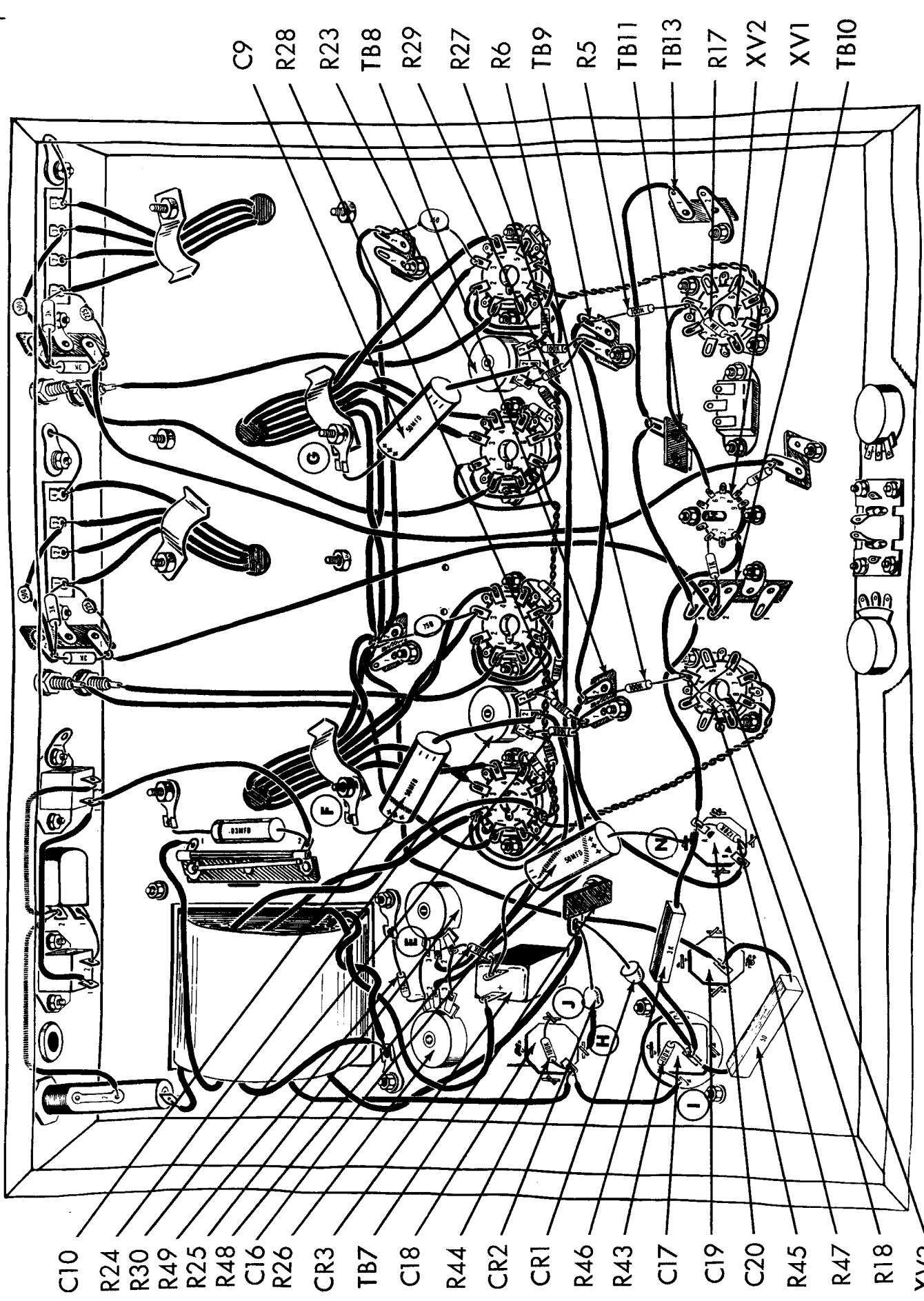

Fig. 5



- () 1. Fig. 5. Cut all leads on three 50mf, 150 volts electrolytic capacitors, C9, C10 and C16 to 1 1/2". Cover each lead with a 1 1/4" piece of spaghetti. Connect the positive (+) lead on C16 to ground lug "N" (S1) at C20 and the negative (-) lead to CR3-2 (C). Connect the positive (+) lead on C9 to ground lug "G" (S1) and the negative lead to R23-2 (S2). Connect the positive (+) lead on C10 to ground lug "F" (S1) and the negative (-) lead to R24-2 (S2).
- () 2. Fig. 5. Connect a 7" piece of orange wire from TB8-2 (C) to TB9-2 (C).
- () 3. Fig. 5. Cut all leads on four 100K 5% (brown, black, yellow, gold) resistors, R27, R28, R29 and R30, to 3/4". Connect R27 from R23-3 (S2) to TB9-1 (C). Connect R29 from R23-1 (S2) to TB9-1 (C). Connect R28 from R24-3 (S2) to TB8-1 (C). Connect R30 from R24-1 (S2) to TB8-1 (C).
- () 4. Fig. 5. Connect a 3" piece of red wire from C17 (C) to lug "I" (C) at C18.
- () 5. Fig. 5. Cut all leads on two 100K 10% (brown, black, yellow, silver) resistors, R43 and R44, to 1/2". Connect R43 from C17 (C) to lug "I" (S2) at C17. Do not short lug to chassis ground. Connect R44 from C18 (S3) to lug "J" (S1) at C18.
- () 6. Fig. 5. Cut both leads on a 50Ω 10 watt wire wound resistor R45, to 1 1/4". Cover each lead with a 1" piece of spaghetti. Connect from C17 (C) to C19 (S2).
- () 7. Fig. 5. Cut both leads on a 3000Ω, 5 watt, wire wound resistor, R46, to 1 1/2". Cover each lead with a 1 1/4" piece of spaghetti. Connect from C17 (C) to C20-A (C).
- () 8. Fig. 5. Connect a 5" piece of red wire from C20-A (C) to TB10-3 (C).
- () 9. Fig. 5. Connect a 4" piece of red wire from TB10-3 (C) to TB11 (C).
- () 10. Fig. 5. Connect a 4" piece of red wire from TB11 (C) to TB13-1 (C).
- () 11. Fig. 5. You have been supplied in your kit with two silicon rectifiers, CR1 and CR2. Note that excessive heat on the leads of these rectifiers can ruin them. When you solder be careful not to apply any excessive heat to the junctions.
While soldering, place a pair of long nose pliers on the lead between the soldered junction and the rectifier to conduct the heat away from the iron so that the heat will not reach the rectifier. With this precaution in mind, you are now ready to wire your rectifiers into the circuit. The rectifiers may take different shapes. The various shapes are indicated in the introductory section to this instruction book. In this same section of the book you will also find the side which is the cathode of the rectifier. Do not cut the leads on either rectifier. Place a piece of spaghetti over the cathode lead of each rectifier. The piece of spaghetti should be of the right length so that 1/4" of lead sticks out from the spaghetti. This 1/4" extension is to be used in making a mechanical connection to the solder lugs. Connect the spaghetti covered cathode lead of CR1 to C17 (S4) and the other lead to TB7 (C). Connect the spaghetti covered cathode lead of CR2 to TB7 (S3) and the other lead to ground lug "H" (S1) at C18.
- () 12. Fig. 5. Connect a 1 1/4" piece of bare wire from R26-3 (S1) to R25-1 (C).
- () 13. Fig. 5. Connect a 1 1/4" piece of bare wire from R26-1 (C) to R25-3 (S1).
- () 14. Fig. 5. Cut both leads on a 10K (brown, black, orange, silver) resistor R48, to 3/4". Connect from CR3-2 (S2) to R25-1 (S2).
- () 15. Fig. 5. Cut both leads on a 15K (brown, green, orange, silver) resistor R49, to 3/4". Connect from R26-1 (S2) to ground lug "E" (S1).
- () 16. Fig. 5. Cut both leads on a 120K (brown, red, yellow, silver) resistor R47, to 1/2". Connect from C20-B (S2) to C20-A (C).
- () 17. Fig. 5. Cut all leads on two 100K 5% (brown, black, yellow, gold) resistors, R5 and R6, to 3/4". Connect R5 from XV2-4 (C) to TB9-2 (S2). Connect R6 from XV3-4 (C) to TB8-2 (S3).
- () 18. Fig. 5. Connect a 1 1/2" piece of bare wire from XV2-3 (C) to XV2-6 (S1).
- () 19. Fig. 5. Connect a 4" piece of green wire from XV1-6 (S1) to XV2-4 (C).
- () 20. Fig. 5. Connect a 1 1/2" piece of bare wire from XV3-3 (C) to XV3-6 (S1).
- () 21. Fig. 5. Cut all leads on two 1 meg (brown, black, green, silver) resistors, R17 and R18, to 1/2". Connect R17 from XV2-1 (C) to XV2-4 (S3). Connect R18 from XV3-1 (C) to XV3-4 (S3).

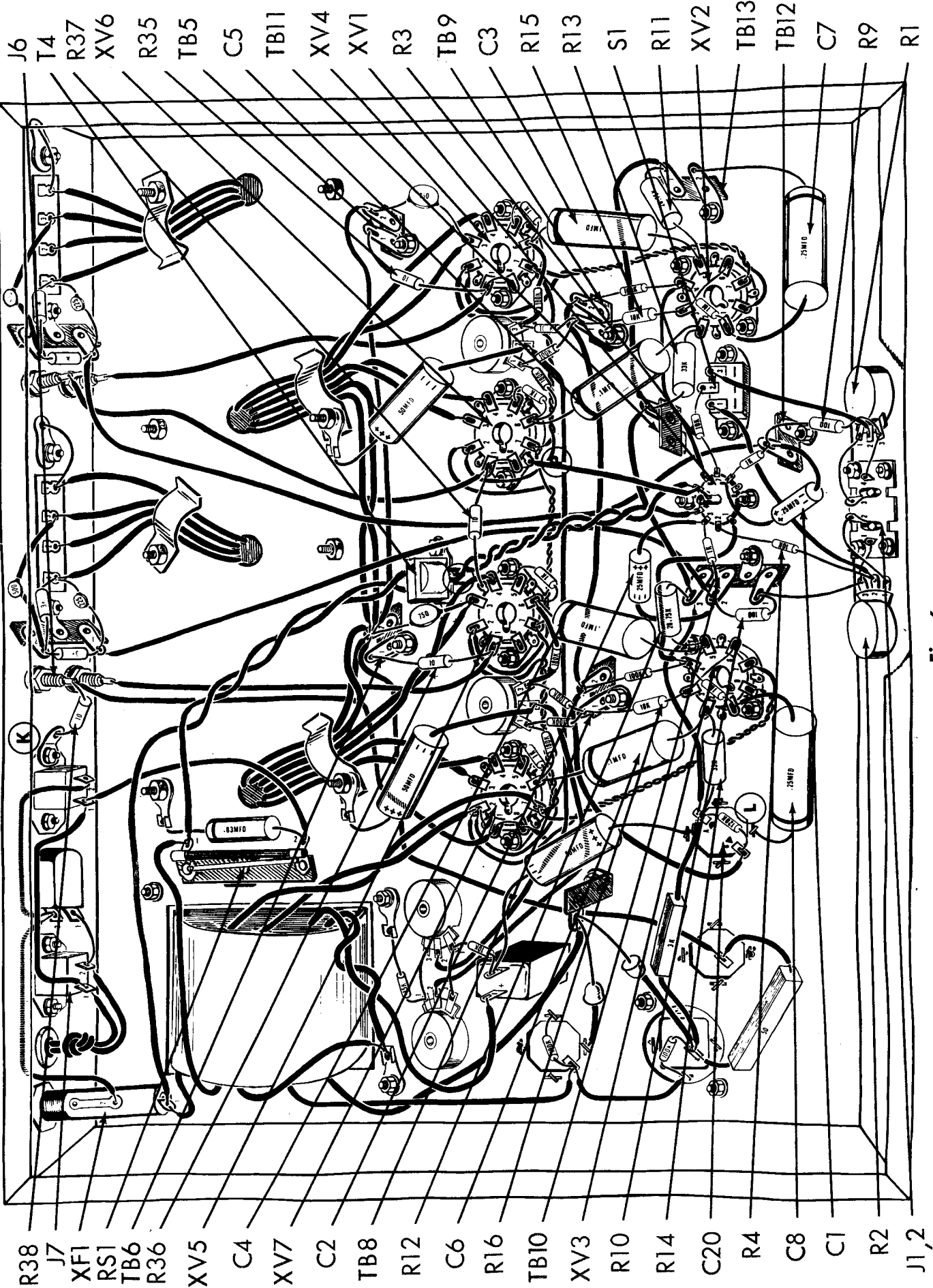

Fig. 6

- () 1. Fig. 6. Connect a 1/4" piece of bare wire from R2-3 (C) to TB10-1 (C).
- () 2. Fig. 6. Connect a 1 1/4" piece of bare wire from J1, 2-1 (S1) to R2-3 (S2).
- () 3. Fig. 6. Connect a 1 1/2" piece of bare wire from J1, 2-2 (S1) to R2-1 (S1).
- () 4. Fig. 6. Connect a 1 1/4" piece of bare wire from J1, 2-4 (S1) to R1-3 (C).
- () 5. Fig. 6. Connect a 1 1/4" piece of bare wire from J1, 2-3 (S1) to R1-1 (S1).
- () 6. Fig. 6. Connect a 3" piece of green wire from R1-2 (S1) to S1-3 (S1).
- () 7. Fig. 6. Connect a 4" piece of green wire from R2-2 (C) to S1-1 (S1).
- () 8. Fig. 6. Cut both leads on a 25mfd 6 volt electrolytic capacitor, C1, to 1". Cover each lead with a 3/4" piece of spaghetti. Connect the positive lead to XV1-8 (S2) and the negative lead to TB12 (C).
- () 9. Fig. 6. On the other 25mfd 6 volt electrolytic capacitor, C2, cut the positive lead to 3/4". Cover this lead with a 1/2" piece of spaghetti and connect to XV1-3 (S2). Cut the remaining lead to 1 1/4" and cover it with a 1" piece of spaghetti. Connect this lead to TB10-2 (C).
- () 10. Fig. 6. Cut all leads on two 100Ω (brown, black, brown, gold) 5% resistors, R9 and R10, to 1/2". Connect R9 from TB12 (S4) to R1-3 (S2). Connect R10 from TB10-1 (S2) to TB10-2 (S4).
- () 11. Fig. 6. Cut one lead of the 10K (brown, black, orange, silver) resistor R3 to 1/2" and the remaining lead to 1". Connect the shorter lead to XV1-7 (S1) and the longer lead to S1-2 (S1).
- () 12. Fig. 6. Cut one lead on the 10K (brown, black, orange, silver) resistor, R4, to 1/2" and the remaining lead to 1 1/4". Connect the shorter lead to XV1-2 (S1) and the longer lead to R2-2 (S2).
- () 13. Fig. 6. Cut all leads on two .25 mfd (red, green, yellow, white, yellow) 400 volt molded capacitors, C7 and C8, to 1 1/4". Cover one lead of C7 with a 1" piece of spaghetti and connect to XV2-1 (S2). Connect the remaining lead to TB13-2 (S1). Cover one lead of C8 with a 1" piece of spaghetti and connect to XV3-1 (S2). Connect the remaining lead to ground lug "L" (S1), at C20.
- () 14. Fig. 6. Cut all leads on two 18K (brown, grey, orange, gold) 5%, 1 watt resistors R15 and R16, to 3/4". Connect R15 from XV2-3 (S2) to TB9-1 (S3). Connect R16 from XV3-3 (S2) to TB8-1 (S3).
- () 15. Fig. 6. Cut all leads on two 28.75K (red, grey, grey, gold) 5%, 1 watt resistors, R11 and R12, to 1/2". Connect R11 from TB13-1 (S2) to XV2-5 (C). Connect R12 from XV3-5 (C) to TB10-3 (S3).
- () 16. Fig. 6. Cut all leads on two 33K (orange, orange, orange, gold) 5%, 1 watt resistors, R13 and R14, to 3/4". Connect R13 from XV2-2 (C) to TB11 (S3). Connect R14 from XV3-2 (C) to C20-A (S4).
- () 17. Fig. 6. Cut all leads on four .1mfd (brown, black, yellow, white, blue) molded capacitors, C3, C4, C5, and C6, to 1". Connect C3 from XV2-5 (S2) to XV4-6 (S3). Connect C5 from XV2-2 (S2) to XV6-6 (S3). Connect C4 from XV3-5 (S2) to XV5-6 (S3). Connect C6 from XV3-2 (S2) to XV7-6 (S3).
- () 18. Fig. 6. Cut both leads on the 100Ω, 1 watt, 1% resistor, R38 to 3/4". Connect from J6 (S2) to ground lug "K" (S1).
- () 19. Fig. 6. Cut all leads on three 100Ω, 1 watt, 1% resistors, R35, R36 and R37 to 3/4". Connect R35 from XV4-1 (S3) to TB5-1 (S1). Connect R37 from XV6-1 (S3) to ground lug "N" (S1) at XV5. Connect R36 from XV5-1 (S3) to TB6-1 (S1).
- () 20. Mount filament transformer T4 as shown. Use two #6-32 screws, two #6 lockwashers and two #6-32 hex nuts.
- () 21. Connect a 3" piece of yellow wire from the center post (S1) on XVI, through XV1-5 (C) to ground lug "P" (S1) on XV6.
- () 22. From filament transformer T4, cut both green leads to 4". Strip the insulation off 1/4" from the ends of each lead. Twist the leads together, and run them along the chassis as shown, under R37. Connect one green lead to XV1-4 (S1) and the second green lead to XV1-5 (S2).
- () 23. From filament transformer T4, cut one black lead to 8" and the second black lead to 12". Strip the insulation off 1/4" from the end of each lead. Twist the leads together and run them along the chassis as shown. Connect the shorter black lead to RS1-1 (S2) and the longer black lead to XF1-1 (S2).
- () 24. Fig. 6. Push the end of the line cord with tinned leads through the rubber grommet at the rear of the chassis. Tie a knot in the line cord 2" from the tinned ends. This knot is to be tied inside the chassis so that the line cord cannot pull through the grommet. Connect one of the tinned leads to J7-2 (S2) and the remaining tinned lead to J7-1 (S2).

You have now completed the assembly and wiring of your amplifier. When you have completed the following steps your amplifier will be ready for use.

- () 1. To catch any wiring errors, it is suggested that the entire wiring be checked point-by-point against the wiring instructions (and preferably also against the schematic wiring diagram in order to become more familiar with the component layout and circuitry). While doing so, check for rosin joints, loose lumps of solder, poor lead dress, and accidental shorts or leakage paths arising from the flow of rosin between contacts (remove with a stiff brush dipped in carbon tetrachloride, being careful not to inhale fumes or to contact the carbon tetrachloride with your skin).
- () 2. Insert tubes V1 through V7 in their sockets. Be sure to insert the correct tube in each socket. Place a shield over tube V1. Insert fuse F1 in fuseholder. **DO NOT PLUG CORD INTO POWER LINE.**
- () 3. If you have a VTVM or VOM, make the following resistance checks before connecting to the a-c line: Check for a cold d-c resistance of at least 80 ohms across the a-c line plug. Check for a resistance of at least 25,000 ohms between ground and each red lead from the power transformer and between ground and the positive terminal of each 300mfd capacitor. Note that the negative lead from the meter is to be connected to ground during the latter measurements. Allow sufficient time for the electrolytic capacitors to be charged by the ohmmeter battery in these last measurements. These measurements constitute a reasonable check of the power supply components and wiring before applying power. If you do not obtain the minimum resistance values indicated, do not proceed to the next step until the cause is discovered and the condition remedied. Adjust R23, R24, R25 and R26 to mid-rotation. Careful adjustment should be made as outlined in the instruction book. Make these careful adjustments immediately after the unit has been turned on. Repeat after 15 minutes and then repeat again after two hours. Repeat in two weeks, after which all adjustments should be permanent.

When you turn the HF-89 "on" for the first few times it is normal for the Sargistor to get hot and smoke slightly. If it glows red hot, you have a short in the power supply and should immediately turn the unit off.

- () 4. Press a No. 8 tinnerman speed nut in place over each hole on the bottom flange of the chassis. (See Figure 7).
- () 5. If the amplifier is not going to be fastened to some surface, insert the rubber feet in the openings provided in the bottom plate and mount the bottom plate of the chassis, using 10 No. 8-32 screws. If the amplifier

is to be fastened to a surface, the feet will not be used and the bottom plate will be required as a template before it is attached to the amplifier.

- () 6. Read the **MECHANICAL INSTALLATION and ELECTRICAL INSTALLATION** sections of the instruction book carefully, and install and connect the amplifier according to the information given.

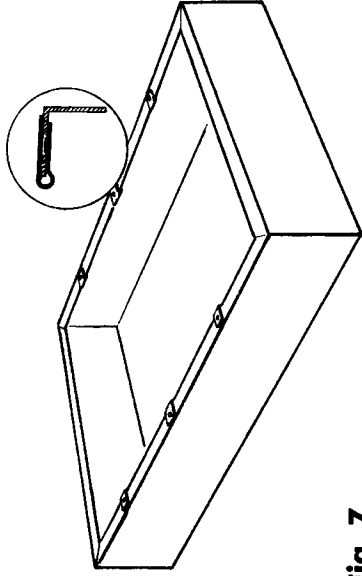

Fig. 7

SERVICE

If you are still having difficulty, write to our service department listing all possible indications that might be helpful. Note the code numbers printed in red under the word "Manual" on the front cover. If there is no code number, state this. If desired, you may return the amplifier to our factory where it will be placed in operating condition for \$9.00 plus the cost of parts replaced due to their being damaged in the course of construction. This service policy applies only to completed amplifiers constructed in accordance with the instructions as stated in the manual. Amplifiers that are not completed or are modified will not be accepted for repair. Instruments that show evidence of acid core solder or paste fluxes will be returned not repaired. **NOTE:** Before returning this unit, be sure all parts are securely mounted. Attach a tag to the amplifier, giving your home address and the trouble with the unit. Pack very carefully in a rugged container, using sufficient packing material (cotton, shredded newspaper, or excelsior), to make the unit completely immovable within the container. The original shipping carton is satisfactory, providing the original inserts are used or sufficient packing material is inserted to keep the amplifier immovable. Ship by prepaid Railway Express, if possible, to the Service Dept., Electronic Instrument Co., Inc., 33-00 Northern Blvd., L. I. C. 1, New York. Return shipment will be made by express collect. Note that the carrier cannot be held liable for damages in transit if packing, **IN HIS OPINION**, is insufficient.

If it is desired to provide a good building ground for your entire system, run a lead from under either speaker connection terminal "G" to a cold water pipe. Do not connect such a ground wire to other components in the system.

If the trouble is no output or low output and the amplifier is suspected, check AC signal voltages starting at the input and work step-by-step toward the output, using a sine-wave audio signal generator and a VTVM. Set the input signal to 0.5 volt. The corresponding grid and plate signal voltages for this input are indicated on the voltage chart. Repeat for the second channel. This procedure should suffice to localize the defective stage.

If the trouble is an excessively distorted output, try tube replacement, signal tracing, or proceed directly to volt- and resistance measurements.

When the defective stage is localized, proceed to a resistance and voltage check of the stage, using the data in the Voltage and Resistance chart. Disconnect the amplifier from the power line and discharge capacitors prior to making any resistance check or removing the EL34 output tubes. Do not turn the amplifier on with any of the output tubes removed.

CHECKING A TYPICAL TUBE STAGE

1. Check tube.
2. Check plate and cathode resistors.
3. Check coupling capacitors for leakage or short.
4. For output stage, check dc resistance of transformer windings.
5. Check for open grid leak resistor.
6. Check cathode by-pass capacitors for short.

7. If no or low B+ voltage on the tube, check decoupling path for open or defective R45, R46 or R47, shorted or defective C17, C18, C19, or C20. Also check rectifiers CR1, CR2, or CR3 for defect.

8. If wiring and circuit components including the tube check O. K. and B+ voltage is excessive, check the decoupling path for shorted or defective R45, R46 or R47.

SERVICE

If trouble develops in your instrument which you can not remedy yourself, write to our service department listing all possible indications that might be helpful. Mention any code numbers in red under the word "Manual" on the front cover. If there is no code number, state this. If desired you may return the instrument to our factory where it will be placed in operating condition for \$9.00 plus the cost of parts replaced due to their being damaged in the course of construction. NOTE: Before returning this unit, be sure all parts are securely mounted. Attach a tag to the instrument, giving your home address and the trouble with the unit. Pack very carefully in a rugged container, using sufficient packing material (cotton, shredded newspaper, or excelsior), to make the unit completely immovable within the container. The original shipping carton is satisfactory, providing the original inserts are used or sufficient packing material inserted to keep the instrument immovable. Ship by prepaid Railway Express, if possible, to the Service Dept., Electronic Instrument Co., 33-00 Northern Blvd., Long Island City 1, New York. Return shipment will be made by express collect. Note that a carrier cannot be held liable for damages in transit if packing IN HIS OPINION, is insufficient.

TRANSFORMER TEMPERATURE

The normal operating temperature of the power transformers in the HF-89 is less than 195°F despite the fact that the safety limit is a much higher 221°F. While 195°F is cool for the transformer, it is very hot to the touch. Transformers which seem too hot when touched, are usually good and are actually not overheating.

VOLTAGE AND RESISTANCE CHART

TUBE	PIN#	DC VOLTS NO SIGNAL	DC VOLTS 100 WATTS	AC VOLTS (1KC) .5 VOLTS INPUT	RESISTANCE, Ω UNIT OFF
12AX7/ECC83 V1	1	138	137	3.8	223K
	2	0	0	.5	510K
	3	1.2	1.2	.44	1.1K
	4	filament (12.6 volts to pin 5)			
	5	filament (ground potential)			
	6	138	137	3.8	223K
	7	0	0	.5	510K
	8	1.2	1.2	.44	1.1K
	9	filament (6.3 volts to pin 4 or 5)			
6SN7GTB V2, V3	1	130	127	.0025	1.22M
	2	335	330	26	36K
	3	147	146	1.8	18K
	4	138	137	3.8	223K
	5	340	335	26	32K
	6	147	146	1.8	18K
	7	filament (ground potential)			
	8	filament (6.3VAC to pin 7)			
EL34/6CA7 V4, V5, V6, V7	1	.63	1	1.4	10 Ω
	2	filament (ground potential)			
	3	475	430	220	45 Ω
	4	478	472	90	19 Ω
	5	-38	-42	26	241K
	6	-38	-42	26	240K
	7	filament (6.3VAC to pin 2)			
	8	.63	1	1.4	10 Ω

Service Sel Sw is in combined position. For test with signal, use one load resistor across each speaker output terminal strip. All voltages and resistances are measured with a high input impedance VTVM. All resistance measurements are made with C19 grounded. Both input level controls set fully clockwise. Operating line voltage at which voltage measurements are made is 117 volts AC, 60 cps. NOTE: ALL VOLTAGE & RESISTANCE VALUES MAY VARY NORMALLY BY $\pm 20\%$.

TROUBLE-SHOOTING PROCEDURES

SYMPTOM	CAUSE	REMEDY
House power line fuse blows; fuse, F1, remains intact.	Short in line cord, J7, J8, or associated equipment plugged into J7 or J8.	Repair
Fuse, F1, blows.	Check CR1, CR2, CR3, C17, C18, C19 or short between insulated tabs on C17 and chassis.	Check and repair or replace.
	Balance and Bias pots not adjusted properly.	Readjust
All tube filaments except V1 not lit. V1 filament not lit. DC voltage at red lead of T2 or T3 is incorrect as specified below.	Open lead from 6.3V winding of T3. 6.3V winding of T3 open. V1, T4, or wiring defective	Repair Replace T3 Repair or replace
a) No voltage	Defective CR1 or CR2. C17 or C18 shorted internally or externally. Connection to C18 broken.	Replace Replace or repair Repair
b) High voltage	Output tubes V4 and V6 or V5 and V7 over-biased or not drawing current.	See trouble-shooting typical stage. Adj. bias and balance pots
c) Low voltage	Excessive current drain in amplifier. Defective CR1 or CR2.	See trouble-shooting typical stage. Replace
	Surgistor not closing completely after 60 seconds.	Repair or replace
	Balance & Bias adjust inaccurate	Readjust

NOTE: A slight red glow on the plates of the EL34 tubes is normal and does not indicate any overload.

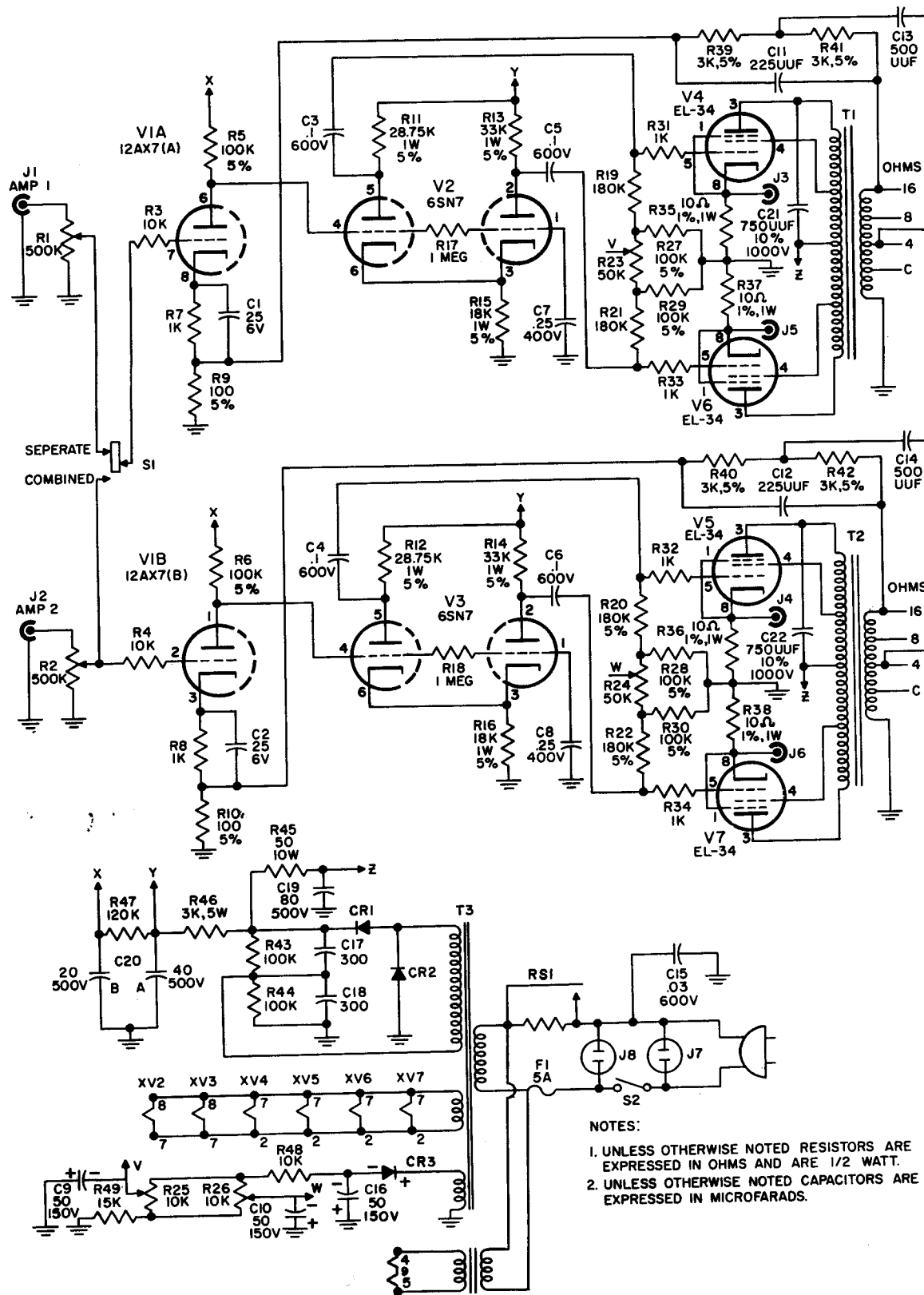

NOTES:

1. UNLESS OTHERWISE NOTED RESISTORS ARE EXPRESSED IN OHMS AND ARE 1/2 WATT.
2. UNLESS OTHERWISE NOTED CAPACITORS ARE EXPRESSED IN MICROFARADS.

EICO

EICO

MODEL HF 89 STEREO DUAL POWER AMPLIFIER



REPLACEMENT PARTS LIST

Stock #	Sym.	Description	Amt.	Stock #	Sym.	Description	Amt.
23026	C1,2	cap., elec., 25mfd, 6V	2	54006	TB10	terminal strip, 3 post, 2 right	1
20040	C3,4,5,6	cap., molded, .1mfd, 600V, ±10%	4	54000	TB11, 12	terminal strip, 1 post left	2
20044	C7,8	cap., molded, .25mfd, 400V	2	54013	TB13	terminal strip, 1 post left w/gnd.	1
23015	C9,10,16	cap., elec., 50mfd, 150V	3	90034	V1	tube, 12AX7/7025/ECC83	1
22543	C11,12	cap., disc, 225mmf, ±10%	2	90041	V2,3	tube, 6SN7GT8	1
22515	C13,14	cap., disc, 500mmf, ±10%	2	90040	V4,5,6,7	tube, EL34	2
20043	C15	cap., molded, .03mfd, 600V	1	97800	XF1	fuzeholder	1
24013	C17,18	cap., elec., 300mfd, 300V	1	97027	XV1	socket, 9 pin min., top mount	1
24014	C19	cap., elec., 80mfd, 500V	2	97032	XV2,3,4,5,6,7	socket, octal	6
24008	C20	cap., elec., 40-20mfd, 500V	1	40000		nut hex, #6-32	37
22542	C21,22	cap., disc, 750mmf	2	40001		nut hex, 3/8	2
93006	CR1,2	rectifier, silicon, 750ma, 600PIV	2	40002		nut hex, 15/32	1
93003	CR3	rectifier, selenium, 50ma	1	40003		nut hex, 15/32	1
91001	F1	fuse, 5 AMP	1	40007		nut hex, #4-40	1
50011	J1-2	jack, dual input	1	40008		nut hex, #8-32	6
50007	J3,4,5,6	jack, pin	1	40012		nut hex, #10-32	4
50016	J7,8	convenience outlet	4	40016		nut hex, 1/2-24	8
18050	R1,2	pot., 500KΩ, slotted shaft, audio taper	2	40017		nut, flinnerman, #8	1
10400	R3,4,48	res., 10KΩ, 1/2W, ±10% (brown, black, orange, silver)	3	41000		screw, #6-32 x 1/4	10
11527	R5,6,27,28,29,30	res., 100KΩ, 1/2W, ±5% (brown, black, yellow, gold)	6	41003		screw, #8-32 x 3/8	36
				41016		screw, #4-40 x 1/4	10
				41016		screw, #8-32 x 1	6
10432	R7,8,31,32,33,34	res., 1KΩ, 1/2W, ±10% (brown, black, red, silver)	6	41028		screw, #10-32 x 3/8	4
				41044		screw, #10-32 x 3/8	8
11505	R9,10	res., 100Ω, 1/2W, ±5% (brown, black, brown, gold)	2	42000		washer, lock, 3/8	2
11601	R11,12	res., 28.75KΩ, 1W, ±5%	2	42001		washer, flat, 3/8	2
11602	R13,14	res., 33KΩ, 1W, ±5% (orange, orange, orange, gold)	2	42002		washer, flat, 3/8	2
11600	R15,16	res., 18KΩ, 1W, ±5% (brown, grey, orange, gold)	2	42004		washer, lock, #6	34
10407	R17,18	res., 1MΩ, 1/2W, ±10% (brown, black, green, silver)	2	42007		washer, lock, #10	8
11537	R19,20,21,22	res., 180KΩ, 1/2W, ±5% (brown, grey, yellow, gold)	4	42008		washer, lock #4	6
18029	R23,24	pot., 50KΩ, snap in	2	42011		washer, lock #8	4
18015	R25,26	pot., 10KΩ, snap in	2	42029		washer, flat, #10	8
11703	R35,36,37,38	res., 10Ω, 1W, ±1%	4	42032		washer, rubber, 1/2 ID	1
11513	R39,40,41,42	res., 3KΩ, 1/2W, ±5% (orange, black, red, gold)	4	43000		washer, #8 flat	4
10410	R43,44	res., 100KΩ, 1/2W, ±10% (brown, black, yellow, silver)	2	43002		lug, ground, #6	3
14306	R45	res., 50Ω, 10W, ±10%	1	43004		lug, ground, #10	2
14505	R46	res., 3KΩ, 5W, ±10%	1	46000		lug, ground, #8	2
10444	R47	res., 120KΩ, 1/2W, ±10% (brown, red, yellow, silver)	1	46006		grommet, 3/8	1
10416	R49	res., 15KΩ, 1/2W, ±10% (brown, green, orange, silver)	1	51006		feet, rubber	4
39001	R51	suristor	1	58004		plug, RCA phono	2
62002	S1	switch, slide, SPDT	1	58004		line cord	1
61000	S2	switch, toggle, SPST	1	58300		wire, hookup #22, solid	length
32024	T1,2	transformer, output	1	58501		spghetiti (insulating sleeve)	length
30031	T3	transformer, power	2	59508		wire, bare #22	length
30041	T4	transformer filament	1	81208		capacitor mounting plate (various colors)	1
54500	TB1,2	terminal board, 4 screw	1	81216		bottom plate	1
54003	TB3,4	terminal strip, 2 post	2	81903		chassis	1
54002	TB5,6,8,9	terminal strip, 1 post right w/gnd.	2	97300		cable clamp	4
54017	TB7	terminal strip, upright, 1 post right	4	66086		tube shield	1
			1	66340		instruction manual	1
						construction manual	1