

CONSTRUCTION BOOK

The EICO kit you are about to assemble and wire has been designed to meet the highest standards of performance. It is a high quality amplifier to be constructed from the finest components available anywhere.

The following Construction Book has been written to carefully guide you through the construction of your kit. If you follow all the instructions implicitly, and work carefully without haste, you will be rewarded with many years of fine performance from this amplifier and a personal inner satisfaction from a job well done.

Your Construction Book: Beginning with the number on this page, and throughout the rest of your Construction Manual, the page numbers are followed by a "C" (1C, 2C, etc.). The instruction Manual, detailing the installation, operation and maintenance of your amplifier, are identified by numerals only, without any letters following these numerals.

Observe that the Instruction Manual section precedes this page and follows the last page of your Construction Book section. After you are certain that you have successfully completed the wiring of your kit, you no longer need the Construction Book. You may remove these centrally located Construction pages, leaving the Instruction section intact for future reference. Keep the Instruction Manual for information as to the installation and operation, as well as for any maintenance that may be necessary in the future, on your amplifier.

Choosing a Workbench and Tools: To avoid the accidental loss or misplacement of components, choose a convenient workbench before unpacking your new kit. You will find it most advantageous to choose a corner on a table that will not be used for any other purpose until you have completed the construction of your kit. Proper precautions should be observed to prevent damage to any table top from a soldering iron or any heavy tools.

When you check the component parts against the Parts List later on, it will be convenient to separate the various pieces into types of components and hardware sizes. It will be convenient to keep these sorted pieces separated in the compartments of specially made trays. Small cartons, egg trays or a refrigerator ice tray with dividers serve equally well.

Several basic tools are required to constructing this kit. They are:

1. Screwdriver - 3/16" to 1/4" blade
2. Screwdriver - 1/8" blade
3. Longnose pliers - 5" or 6"
4. Diagonal wire cutters
5. Soldering Iron (100 watts), solder gun or pencil iron (35 watts).
6. Gas Pliers
7. High quality rosin core radio solder. DO NOT use Acid Core solder or Paste fluxes under any circumstances.

The following tools are useful, but are not absolutely necessary to construct this kit:

1. Socket wrench set
2. Open end wrench set
3. Wire stripper

Unpacking the kit: This procedure serves two purposes. First it permits you to become acquainted with the various types of components. Secondly, it enables you to ascertain if you received all the parts required to build the kit. This is your opportunity to have any packing errors corrected.

When unpacking, handle all parts carefully so that you will not damage any fragile components. Do not throw any packing material away until after having checked all components. Check each part off against the "Parts List" which you will find in your Instruction Book. Check the packing for any small parts.

From time to time, due to modernization or possible error, corrections may be necessary to your Parts List. If there are any changes to be made, they will be listed on the loose addenda sheets included with this book. Make the corrections if any, before checking your components. If no corrections of your Parts List are noted on the addenda sheets, or there are no addenda sheets, assume your Parts List is correct, and commence to check all components against this list.

To enable rapid identification of electronic parts, each part has been assigned one or two letters of the alphabet called a "reference designation". These "reference designations" are nothing more than an initial letter or two representing the name of the part. For example, a vacuum tube has been assigned the reference designation letter V, and a transformer the letter T. Thus, if you have eleven vacuum tubes and three transformers in your kit, these parts would be identified by the designation V1 through V11 and T1 through T3, respectively.

40 WATT INTEGRATED STEREO AMPLIFIER

MODEL
ST 40



EICO

INSTRUCTION

MANUAL

ST 40-1

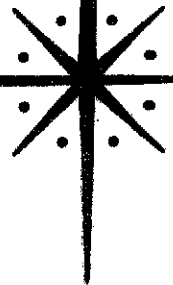

ELECTRONIC INSTRUMENT CO. INC.
3300 NORTHERN BLVD., L. I. CITY 1, N. Y.



40 WATT INTEGRATED STEREO AMPLIFIER

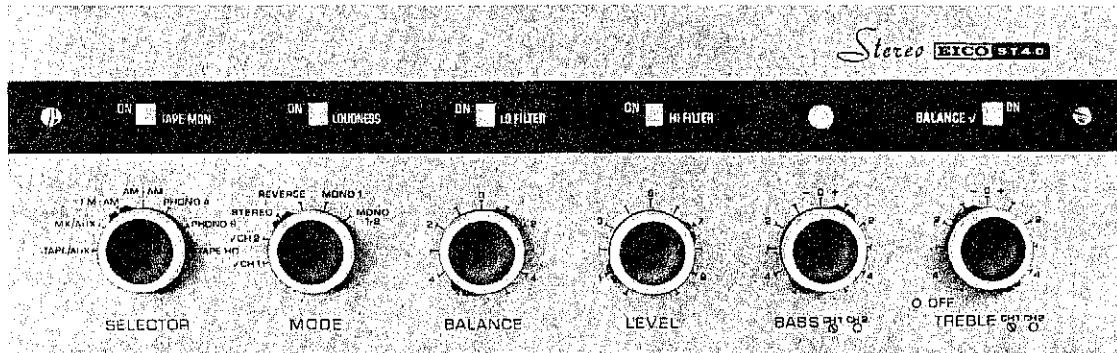

GENERAL DESCRIPTION

The EICO Model ST-40 is a complete high fidelity stereophonic control center and a pair of 20-watt amplifiers, all on one chassis. With it, you can select, preamplify, and control any stereophonic or monophonic source and feed it through the self-contained dual 20 watt amplifiers to a stereo pair of speaker systems. Provision is made for operating a center speaker directly from the ST-40.

FEATURES

1. Provision for two stereo phono cartridges to be connected. Permits the use of both a turntable and a record changer in the installation. One pair presents 47K Ω load and the other pair 100K Ω load, to cover most popular cartridges. RIAA equalization.
2. Provision for connecting stereo tape heads. MARTB equalization for 7 1/2 ips.
3. High level input pairs for multiplex adaptor, pre-amplified and equalized tape, FM tuner, and AM tuner.
4. Separate level and balance controls. Null-type balance checking circuit.
5. Switched high and low frequency filter circuits permit elimination of rumble problem or scratch and distortion when need be.
6. Switched loudness compensation.
7. Tape monitor switch.
8. Feedback equalization, with feedback around both preamplifier stages. High overload point.
9. Bass and treble tone controls are of the variable inflection point, feedback type for exceptionally low distortion and the most desirable control characteristics. These controls do not affect the volume or interact with each other, and boost or cut at the extremes of the audio range do not affect the mid-range.
10. Separate filament windings and hum balance controls for each channel permit an optimum hum balance for each channel, rather than a compromise for both channels.
11. Unused inputs grounded by SELECTOR switch to eliminate cross-talk — except for TAPE inputs, since some tape machines are adversely affected if playback outputs are grounded during recording.
12. Provision for feeding a center speaker directly from the ST-40.
13. Conservatively operated 7591 output tubes, and highly efficient GZ34 rectifier.

SPECIFICATIONS

POWER OUTPUT: 40 watts total; 20 watts each channel continuous sine wave power

IM DISTORTION (60 & 7000 CPS at 4:1): 1% at 20W each channel; 0.6% at 10W; 0.16% at 1W

HARMONIC DISTORTION: Less than 1% 40-20,000 cps within 1db of 20 watts each channel; less than 1.5% 30-20,000 cps at half-power each channel

FREQUENCY RESPONSE: ± 0.5 db 40-20,000 cps at 20 watts each channel; ± 1 db 12-25,000 cps at 1 watt each channel

<u>INPUT</u>	<u>SENSITIVITY</u>	<u>INPUT IMPEDANCE</u>
Phono A	3Mv	100K Ω
Phono B	3Mv	47K Ω
Tape Head	1.75Mv	1M Ω
FM	360Mv	500K Ω
AM	360Mv	500K Ω
Multiplex	360Mv	500K Ω
Tape	360Mv	500K Ω

TONE CONTROL RANGE: ± 15 db at 50 cps and 10kc

DAMPING FACTOR: 11

SPEAKER CONNECTIONS: 4, 8, 16 Ω

TAPE OUTPUT IMPEDANCE: 400 Ω at 20kc when using low level inputs; same as the output impedance of the source when using high level inputs

TUBES: 2-12AX7, 4-12DW7, 4-7591, 1-GZ34 rectifier

POWER SOURCE: 117V, 60 cps

POWER CONSUMPTION: 165 watts

CONVENIENCE OUTLETS: 1 controlled by power switch, 1 not switched

FUSE: 3 amperes

SIZE (HWD): 5 1/8" x 15 7/8" x 13 1/8"

WEIGHT: 32 lbs.

CABINET INSTALLATION

GENERAL

1. Mount horizontally on a well-braced shelf. The stock thickness of the wood panel may not exceed 3/4".
2. Do not remove feet for mounting. Air must be allowed to enter through the perforations in the bottom plate to avoid overheating.
3. Any shelf above the unit must be spaced away at least 3 inches. Allow at least a 1 1/2" tolerance on each side of the unit.
4. Leave the back of the cabinet entirely open.

PREPARATION OF UNIT

1. Turn unit over and loosen the front and rear pairs of screws (4 in all) that fasten the bottom plate to the side pieces. Remove the center pair entirely. Then turn the unit back right side up.
2. Remove the 6 screws, one on each side, that fasten the cover to the side pieces. Remove the cover and set aside.
3. On the top side of the chassis, loosen all 6 screws (3 on each side) that fasten the chassis to the side pieces.
4. Push both side pieces back as far as they will go. The screws that have been loosened will move from the front to the rear ends of the slots in the chassis and the bottom plate. Then re-tighten all the screws that have been loosened. Check to see that all the tubes are properly seated in their sockets and then replace and re-fasten the cover to the side extrusions.
5. Detach all the knobs from the control shafts and then remove the 4 screws, (2 previously concealed by knobs and 2 in the recessed area) that fasten the panel to the chassis. Lift the panel out over the control shafts and set it aside. The unit is now prepared for cabinet installation.

PREPARATION OF THE CABINET

1. Two templates are provided, one for the cabinet shelf and the other for the cabinet panel. The shelf template is used to locate exactly two holes that are to be drilled in the shelf. The panel template is used to locate exactly the required rectangular cut-out. The two templates must be used together as indicated, as there is an exact relationship between the locations of the shelf holes and panel cut-out.

2. To use the shelf template, cut it or fold it back exactly along the dashed line that corresponds to the panel thickness. Remove the shelf from the cabinet and line up this dashed line on the template with the front edge of the shelf, positioning it also along the edge to leave at least 1 1/2" clearance on each side. Tape the template in position and use a center punch to mark the centers of the two holes to be drilled. If the shelf can not be removed, place the template in a similar manner on the top side of the shelf if there is room to drill from the top side, or on the under side of shelf if there is only room to drill from the under side. If the template is used on the underside of the shelf, mark the rear edge of the shelf at the points where the extended heavy lines on the template hit the rear shelf edge. After the holes are center-punched, remove the template and drill carefully through the punched centers to a diameter of 1/4". If the shelf has been removed for the drilling operation, now re-mount it. Finally, replace the shelf-template in exactly its former position on the top-side of the shelf and tape it down. If the shelf template had been used on the underside of a stationary shelf, now place it on the top-side of the shelf using the marks on the rear edge of the shelf previously made. (In the latter case, accuracy may be improved by cutting the two holes out of the shelf-template with a razor blade and then lining up the holes in the shelf template with the holes in the shelf).

3. To use the panel template, cut it or fold it back exactly along the dashed line. This dashed line corresponds to the junction of the top side of the cabinet shelf and the interior side of the wood panel. Position the panel template against the interior side of the wood panel so that the dashed line rests against the shelf and the two heavy vertical lines in the panel template meet with the two heavy horizontal lines in the shelf templates. Tape the panel template down and use a center-punch to make the centers of the four 3/8" holes in the four corners of the rectangular cut-out shown on the template. Now remove both templates and drill carefully through each of the four punched centers to a

hole diameter of 3/8". On the front side of the wood panel scribe a rectangle externally tangential to the four drilled holes. Check the height and width of the rectangle against the panel template dimensions. These dimensions should not be exceeded. Now carefully cut out the rectangle with a sabre saw, using a small blade to start accurately in the 3/8" holes. After the cutting operation, any rough spots or excess material along the edges of the cut-out may be removed with a file. Finally, brush or blow out all chips and sawdust.

MOUNTING THE UNIT

1. Insert the unit from the rear of the cabinet, carefully guiding the controls through the panel cut-out. Center the unit in the cut-out and re-mount the panel with the four screws previously removed.
2. From the rear of the cabinet, pull the amplifier toward you gently, until the front panel is flush against the wood panel.
3. Now place 5/8" flat washers against the heads of the two #8 x 1 3/4" screws provided and insert them from the bottom side of the shelf into the two holes drilled previously. It may be necessary to shift the unit slightly to the left or right in order to afford clear access for the screws. When both screws have caught, tighten them to secure the unit to the shelf.
4. Replace the knobs previously removed on the control shafts.

INPUT CONNECTIONS

Channel 1 has 7 inputs and channel 2 has 6 inputs, one of which there is no use for at the present time (AM 2).*

The channel 1 inputs are identified by the suffix "1" and are as follows:

CH. 1 Low Level Inputs	CH. 1 High Level Inputs
PHONO A 1	FM 1
PHONO B 1	AM 1
TAPE HEAD 1	Multiplex 1
	TAPE 1

The channel 2 inputs are identified by the suffix "2" and are as follows:

<u>CH. 2 Low Level Inputs</u>	<u>CH. 2 High Level Inputs</u>
PHONO A2	AM 2* (See note)
PHONO B2	MultiplX 2
TAPE HEAD 2	TAPE 2

All high level inputs provide the same gain and flat frequency response. Low level inputs provide much higher gain and the prescribed gain-frequency characteristics of RIAA for phono and NARTB for tape head.

Monophonic sources, such as FM tuner, AM tuner, or monophonic phono cartridge, are plugged into Channel 1 inputs. Stereophonic sources, such as stereo phono cartridge, stereo tape heads, or FM, Multiplex (MX) adaptor, are plugged in as follows: left channel into channel 1 inputs; right channel into channel 2 inputs.

*Input AM 2 is provided against the possibility of AM-AM stereo. AM 1 is the normal AM tuner input.

Setting the SELECTOR switch to FM-AM and the MODE switch to STEREO or REVERSE takes care of feeding two normally monophonic channel 1 inputs (FM tuner and AM tuner) one to channel 1 and the other to channel 2 for FM-AM simulcast stereo.

PHONO

The PH. A input jacks 1 & 2 and the PH. B input jacks 1 & 2 permit the use of two magnetic cartridges in your system. One cartridge can be a stereo type and the other monophonic or both can be stereo. One cartridge can be in a turntable, and the other in a record changer or an inexpensive phono for children's use. A monophonic cartridge is plugged into the channel 1 input only.

When playing a monophonic record with a stereo cartridge, set the MODE switch to the MONO 1-2 position, specifically intended for this purpose. In the MONO 1-2 position, the channel 1 and 2 inputs are fully blended internally, and the blend is fed to both amplifiers. The purpose here is to cancel extraneous vertical noise components in the cartridge output.

When playing a monophonic record with a monophonic cartridge, set the MODE switch to MONO 1, the normal monophonic position at which the channel 1 input is fed to both amplifiers.

The load presented to the cartridge by the PHONO A

inputs is 100K Ω . The load presented to the cartridge by the PHONO B inputs is 47K Ω . The choice of load impedance permits accommodation of most popular cartridges. Most popular cartridges, including all Shure and the Pickering 381A require 47K Ω load. The Pickering 380A, however, requires 100K Ω load.

If the Weathers C501-D cartridge is used, connect a 180K Ω resistor in series followed by a 33K Ω resistor in shunt, to each output. Plug into PHONO A inputs. This network avoids overloading the preamplifier inputs.

X TAPE HEAD

The TAPE HEAD 1 & TAPE HEAD 2 input jacks permit the connection of a tape deck having no playback preamplifiers to the unit. The tape head should be of the conventional high impedance, high output type normally supplied in decks without playback electronics. If the head is of the stereo type, connect the upper track output to TAPE HEAD 1 and the lower track output to TAPE HEAD 2. If the head is of the monophonic type, connect the output to TAPE HEAD 1. The load presented to the tape head by each input is 1 megohm.

FM TUNER

The FM 1 input jack is for connection of an FM tuner.

AM TUNER

The AM 1 input jack is for connection of an AM tuner. Do not use AM 2 for this purpose.

FM MULTIPLEX ADAPTOR

The MX 1 and MX 2 input jacks permit the connection of an FM Multiplex adaptor. Any adaptor will provide a left channel output and a right channel output. The left channel output is connected to MX 1 and the right channel output to MX 2.

X TAPE

The TAPE 1 and TAPE 2 input jacks permits the connection of a tape machine complete with playback preamplifiers. If the machine provides stereo playback, connect the upper track output to TAPE 1, and the lower track output to TAPE 2. If the machine is of the monophonic type, connect the output to TAPE 1.

OUTPUT CONNECTIONS

TAPE RECORDER

The TAPE OUT 1 & TAPE OUT 2 jacks are intended for feeding signals out to the "line" recording inputs of a tape recorder. These are independent outputs for channel 1 and channel 2, respectively. They are unaffected by the LEVEL, BALANCE, BASS, TREBLE, HI FILTER, and LO FILTER controls.

SPEAKER CONNECTIONS

WARNING: Do not operate the amplifier without first connecting speakers to the speaker connection terminals, exactly as described below.

Every speaker has a rated impedance, which may be 16, 8, or 4 ohms. For an amplifier to provide rated power output with rated distortion, the speaker used with it must be connected to the output transformer tap corresponding to its impedance.

On the rear apron of the unit, there are three 4-connection Terminal Boards (TB). Silk-screened on the apron is a diagram for connecting up to three speakers; one each for channels 1 and 2, and an optional center channel speaker.

To agree with the established conventions of stereo, connect the left speaker to the channel 1 output, and the right speaker to the Channel 2 output, after reading the connection information below.

The board at the left, TB1, carries the impedance taps for channel 1. The board at the lower right, TB3, carries the impedance taps for channel 2.

The left board, TB1, carrying the channel 1 impedance taps (16, 8, 4Ω), also includes the common terminal (C) for channel 1. The channel 1 speaker is connected to this common terminal C and the appropriate channel 1 impedance tap, as shown.

The lower right board, TB3, carrying the channel 2 impedance taps (16, 8, 4Ω), does not carry the common terminal C for channel 2. In fact, the channel 2 speaker is not to be directly connected to this board at all. The upper right board, TB2, provides the connection terminals for the channel 2 speaker. As the diagram shows, the channel 2 speaker is to be connected between the right-hand pair of terminals on board TB2. Note that the terminal at the extreme right is marked "C", this being the common terminal for channel 2.

To complete the connection of the channel 2 speaker, a jumper wire must be connected between the third terminal from the right on the upper right board, TB2, and the appropriate impedance tap on the lower right board, TB3, as shown in the diagram.

There is a third speaker shown in the diagram, labelled CENTER SPKR. (OPTIONAL). A resistance symbol is shown in series with this speaker, as well. This resistance symbol stands for an attenuator to reduce the level of the center speaker appreciably below that of the channel 1 and 2 speakers so as to produce "center fill" without markedly diminishing the stereo effect. For this purpose we recommend an adjustable 50 ohm, 25 watt wire-wound dropping resistor such as the Ohmite "Dividohm", mounted on the rear panel of the center channel speaker adjacent to the speaker terminals. Connect the sliding divider on the resistor to one of the speaker terminals, allowing enough slack to permit the slider to be moved along the body of the resistor. Now connect the other speaker terminal to the extreme left-hand terminal on the upper right board, TB2, on the amplifier, and then connect one end terminal of the dividing resistor to the same impedance tap on the left board, TB1, used for the channel 1 speaker. These connections are shown in the diagram.

The speaker connection diagram silk-screened on to the rear apron of the amplifier is reproduced in Fig. 1, with additional polarity indications which will assist in phasing the speakers properly if your speakers are marked as to polarity. A physical representation of the speaker connections is given in Fig. 2. If your speakers are not marked as to polarity, use the phasing method given below.

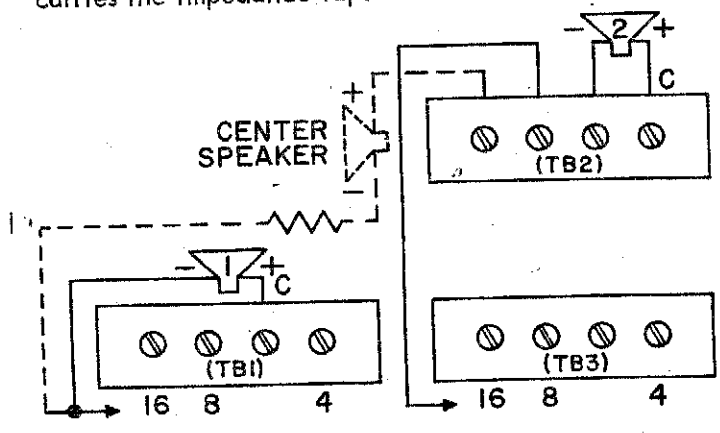

SPEAKER TERMINALS FIG. 1

Set the speakers together, including the center speaker if you are using one. Listen to a monophonic source with plenty of bass material through both channels, and all speakers, at once. Temporarily disconnect one lead going to the center speaker. Now reverse the connections to one outside speaker. If the bass is fuller, the two outside speakers are now in phase. If the bass is thinner, restore the original connections to this outside speaker. Now re-connect the lead previously removed from the center speaker. If the bass is fuller, the center speaker is in phase with the outside speakers. If the bass is thinner, reverse the connections to the center speaker.

NOTE: We do not mean to give the impression that a center channel speaker is normally necessary in a stereo installation. We consider it, rather, to be a convenient facility in the case that the channel 1 and 2 speakers have to be spread apart more than the normal 8 to 10 feet, or that, with normal spacing, listening at close quarters is often necessary. Under these circumstances the sound from the channel 1 and 2 speakers may become disassociated, resulting in a phenomenon known as "hole-in-the-middle". The center channel speaker is a remedy for this situation.

AC POWER CONNECTIONS

Plug the line cord into a 117VAC, 60 cps power line outlet only. A DC power source will cause severe damage to the unit.

Two convenience outlets are provided on the rear apron, one switched and one unswitched. The unswitched outlet should be used with record changers, turntables, or tape decks (devices which can sometimes be harmed if turned off simply by removing power) if it is not convenient to plug them directly into the power line. The switched outlet is for use with tuners. A cube tap may be used if more than one connection is to be made to an outlet.

A 3 amp fuse is provided on an extractor post mounting on the rear apron. This fuse protects only the amplifier, not any equipment plugged into the switched convenience outlet.

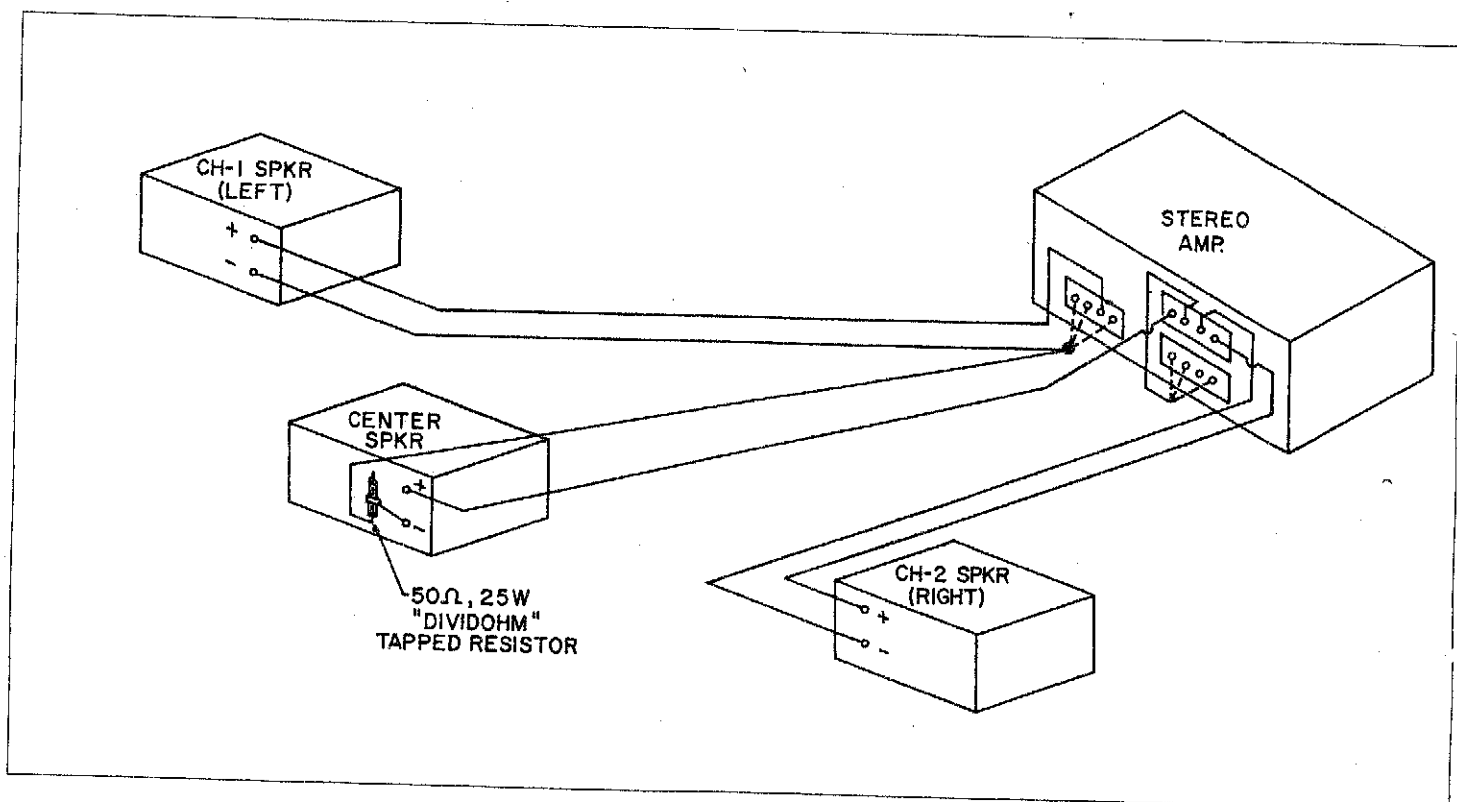

SPEAKER CONNECTIONS FIGURE 2

OPERATION OF CONTROLS

SELECTOR Switch: Used to select any input or pair of inputs as follows:

POSITION	SOURCE	INPUTS	COMMENTS
TAPE /AUX.	Pre-amplified tape	TAPE 1 & TAPE 2	
MX/AUX.	FM Multiplex Stereo	MX 1 & MX 2	
FM-AM	FM tuner & AM tuner	FM 1 & AM 1	FM only with MODE Sw at MONO 1
AM-AM*	AM tuner	AM 1	Set MODE Sw at MONO 1
PHONO A	Stereo mag. phono cartridge	PH. A 1 & PH. A 2	Set MODE Sw at MONO 1-2 to play mono record
PHONO B	Stereo mag. phono cartridge	PH. B 1 & PH. B 2	Set MODE Sw at MONO 1-2 to play mono record
TAPE HD.	Stereo tape head in deck without preamplifiers	TAPE HD. 1 & TAPE HD. 2	

MODE Switch: Used to select mode of operation

POSITION	OPERATION	COMMENTS
CH. 1	CH. 1 input out CH. 1 speaker	For checking left side of stereo program
CH. 2	CH. 2 input out CH. 2 speaker	For checking right side of stereo program
STEREO	CH. 1 input out CH. 1 speaker CH. 2 input out CH. 2 speaker	Should normally give left side of program out of left speaker, and right side of program out of right speaker
REVERSE	CH. 1 input out CH. 2 speaker CH. 2 input out CH. 1 speaker	Use if left side of program is coming out of right speaker when set at STEREO
MONO 1	CH. 1 input out CH. 1 & 2 speakers	Use for all mono listening except when playing mono record. Used also for checking balance in Stereo. See BALANCE ✓ operation.
MONO 1-2	CH. 1 plug CH. 2 inputs blended out CH. 1 & 2 speakers	Used only when playing mono record (with stereo cartridge)

*See note on use of AM 2 in INPUT CONNECTIONS.

BALANCE Control: Used to achieve equal left and right side program levels in stereo. Effective in mono to center the apparent source between the speakers. Neither channel amplifier is favored (as to gain) at the zero setting (mid-rotation). As the control is turned clockwise from zero, the channel 2 (right) speaker is made louder and the channel 1 (left) speaker is made softer, while the overall level remains about the same. As the control is turned counter-clockwise from zero, the channel 1 (left) speaker is made louder and the channel 2 (right) speaker is made softer, while the overall level remains about the same.

BALANCE ✓ (CHECK) Slide Switch: If you have identical left and right speakers (or dissimilar speakers of nearly equal efficiency), the BALANCE control can be set properly by means of the BALANCE ✓ (CHECK) slide switch as follows:

1. Set BALANCE ✓ (CHECK) slide switch to ON
2. Set MODE switch to MONO 1
3. Adjust BALANCE control for minimum sound (null) from the left (CH. 1) speaker. There will be no sound from the right (CH. 2) speaker. If the BALANCE control is turned either direction from the proper setting (null), the sound level from the left speaker will increase.
4. Return the MODE switch to STEREO or REVERSE if the source is stereo.

NOTE:

In the "null" method of balancing just described, this is what is being done. An identical signal is fed to the channel 1 and 2 amplifiers at the high level input points (setting MODE switch to MONO 1). A dummy load is internally substituted for the channel 2 (right) speaker and the channel 2 output signal is fed back through a precision dividing network to the input of the channel 1 power amplifier (setting BALANCE ✓ switch to ON). The channel 2 output signal is out-of-phase with the input signal to channel 1 and tends to cancel or nullify it. When the BALANCE control is set so that the portion of the channel 2 output signal fed to the channel 1 power amplifier input is equal to the channel 1 signal at this point, almost complete cancellation (null) occurs and the output from the channel 1 speaker is at a minimum.

This method of balancing achieves equality of gain in the channel 1 and 2 amplifiers from the high level inputs to the speaker outputs. The preamplifiers, which are ahead of the high level input, are audibly nearly

equal in gain because of feedback. If, upon returning the MODE switch to STEREO or REVERSE after setting the BALANCE control by this method, audible balance is not achieved, the indication is that the sources feeding the amplifier are not equal. If the sources have their own level controls, such as FM or AM tuners or Multiplex adaptors, then these level controls should be set to equal output by successively setting the MODE switch at ✓CH. 1 and ✓CH. 2 while adjusting the source level controls for equal output from each speaker. Once the source levels have been adjusted, the null balancing method described previously will work effectively.

If one speaker is a little more efficient than the other, you may pad down the more efficient speaker by a series resistor up to half the rated speaker impedance (more will unduly deteriorate speaker damping), in order to make the convenient null balancing method effective. If the speakers are grossly different in efficiency, you will have to adjust the BALANCE control by successively setting the MODE switch at ✓CH. 1 and ✓CH. 2, while finding the BALANCE control setting that produces about equal output from each speaker.

If a stereo phono cartridge has a marked difference in output between the two sides, you will have to adjust the BALANCE control setting until audible balance is achieved, while successively setting the MODE switch to ✓CH. 1 and ✓CH. 1 and ✓CH. 2, when this input is selected.

LEVEL control: Used to adjust the listening level in both channels. The BALANCE control is adjusted after setting the LEVEL control. Substantial changes in LEVEL control setting may require re-setting the BALANCE control. Adjust the output level controls in tuners, multiplex adaptor, and tape machines with preamplifiers, to match the sound level obtained on phono, if possible. If any of the high level sources can not provide high enough output to match phono, simply set this source to maximum output.

LOUDNESS slide switch: A characteristic of human hearing is that sensitivity to bass tones diminishes more rapidly, as the listening level is lowered, than sensitivity to middle and high frequency tones. Many people find the audible loss of bass at low listening levels unsatisfying. Setting the LOUDNESS slide switch to ON provides a compensating amount of bass boost at low listening levels. Do not leave the LOUDNESS switch at ON when listening at normal volume, since the amount of bass boost provided will usually be excess-

ive and unmusical. Some people prefer not to use loudness compensation at all, because it does not correspond to any natural listening condition at a live performance.

BASS CONTROL CH. 1, BASS CONTROL CH. 2 (CONCENTRIC): The plus sign on the right side of the dial indicates that clockwise rotation from the mid-point (0) of either control increases (boosts) bass response; the minus sign on the left side indicates that counter-clockwise rotation from the mid-point decreases (cuts) bass response. There is no interaction with the TREBLE control. Start all adjustments with this control set at the mid-point (0), which is called the "flat" position since bass response is neither cut nor boosted at this position.

TREBLE CONTROL CH. 1, TREBLE CONTROL CH. 2 (CONCENTRIC): The plus sign on the right side of the dial indicates that clockwise rotation from the mid-point (0) of either control increases (boosts) treble response; the minus sign indicates that counter-clockwise rotation from the mid-point decreases (cuts) treble response. There is no interaction with the BASS control. Start all adjustments with this control set at the mid-point (0), which is called the "flat" position since treble response is neither cut nor boosted at this position.

The amplifier ON-OFF power switch is ganged with the CH. 2 TREBLE control. Note the word "OFF" on the panel just beyond full-counter-clockwise rotation. The plain circle symbol preceding it indicates that the power switch is ganged with the CH. 2 control. Turn the amplifier off by turning the CH. 2 TREBLE control beyond full counter-clockwise rotation until the power switch clicks to OFF. Turn the amplifier on by turning the CH. 2 TREBLE control clockwise from OFF and setting it at the mid-point (0) or some customary setting of the CH. 2 TREBLE control you may use.

LO FILTER slide switch: Set to ON when it is desired to cut low frequency response below 100 cps because of rumble in a phonograph or even in broadcast program material. Phonograph rumble is usually at about 29 cps and may well not be directly audible. Sometimes it can be at a much lower frequency, which is definitely not directly audible. However, the effect of rumble can be heard even the rumble itself is not. It manifests itself by using up amplifier power at low frequencies and can even overload the amplifier. If, at normal listening levels on phonograph, setting the LO FILTER to ON definitely results in "cleaner", less-distorted sound, the indication is that your phonograph

suffers from excessive rumble. Whether it is worth doing anything about it, depends on the installation. If you have inexpensive speaker systems that do not produce substantial undistorted sound below 80 cycles, you may just as well live with the rumble and eliminate its bad effects by using the LO FILTER. If you have made a considerable investment in speakers, partly in order to obtain full, undistorted response below 80 cycles, you may not want to forego full bass response. In the latter cases, have the phonograph examined by a qualified service man to see if the rumble is caused by a defect that can be remedied.

HI FILTER slide switch: Set to ON when it is desired to cut high frequency response above 5000 cps. Useful for minimizing extraneous noise when listening to narrow range AM broadcasting, for listening to noisy or worn records, and for reducing the annoyance of excessive distortion from any source.

TAPE MONITOR slide switch: Useful with complete tape machines (including record and playback electronics) that provide off-the-tape monitoring facilities while recording. In this situation, setting the TAPE MONITOR slide switch to ON permits you to hear the program being recorded directly from the tape.

MAINTENANCE

INSTALLATION PROCEDURES FOR MINIMUM HUM

AC LINE CORDS: Hum can usually be reduced by the following procedure, after all the equipment used with the amplifier is connected to it and plugged in.

1. Turn on all the equipment used.
2. Reverse the amplifier's AC line cord plug in the wall outlet to see if hum is reduced. Leave it in the position that results in least hum.
3. With the SELECTOR switch, select a particular piece of equipment, and determine the insertion position of its AC line cord plug that results in least hum.
4. Repeat step 3 for every piece of equipment used with the amplifier.

When this is done, proceed to HUM BALANCE adjustments.

HUM BALANCE: Separate filament windings and hum-balance controls are provided for the two channels, so that an optimum hum balance setting can be found for each channel, rather than a compromise setting for both channels. Connect the phonograph and leave it shut-off with the tone arm at rest. Set the SELECTOR to the PH. A or PH. B position depending on which inputs are used. Set the MODE switch at \checkmark CH. 1, BALANCE at 0, LEVEL at 10, BASS 1 & 2 at 0, TREBLE 1 & 2 at 0 (amplifier turned on). Set all slide switches at "off" (down). Adjust the channel 1 hum-balance control (R-77) with a screw-driver until the hum heard from the channel 1 speaker is at a minimum. Now set the MODE switch at \checkmark CH. 2 and adjust the channel 2 hum-balance control (R-78) until the hum heard from the channel 2 speaker is at a minimum. See Figure 3 for the locations of R-77 and R-78.

GROUNDING: The cause of phonograph hum may be a metal pick-up arm not grounded to the cable shield (try a good single ground connection to the cable shield from turntable frame, pick-up arm, and cartridge case), direct hum pick-up by the magnetic cartridge from the record player motor (try using a rubber mat on the turntable to increase the separation of the pick-up from the motor), or pick-up from a power transformer or other magnetic field in the vicinity (try moving phonograph away from suspected source). Check also that the phono input cable shielding is grounded to the amplifier chassis at one point only, through the skirt of the input connector where it plugs into the amplifier. Finally, try a good building ground, such as a connection from a cold water pipe terminated under the channel 2, 4 Ω impedance tap (ground) on the rear apron of the amplifier. Do not connect such a ground wire to other components in the system. If possible, let each channel be connected to the amplifier using a separate shielded cable to the amplifier input. It is also desirable that the ground leads on both cables not be connected together at any point — not even at the cartridge. However, with some cartridges, it will not be possible to do this. In this case, just disregard this last instruction.

SERVICING

GENERAL

Your amplifier should require little service except for normal tube replacement. We recommend no substitutions for the tube types used in this amplifier except as stated. All the tube types used are distributed nationally, but replacements can be obtained directly from EICO if desired.

To facilitate servicing, remedial and trouble-shooting procedures have been provided in the TROUBLE-SHOOTING CHART that follows. A VOLTAGE AND RESISTANCE CHART is also provided as an aid in locating defective components. DC operating voltages are given both at no signal and signal developing 20 watts output, as well as the corresponding 1kc signal voltages.

TROUBLE-SHOOTING PROCEDURES

Connect a stereo phono and a pair of speakers to the amplifier as described in INPUT CONNECTIONS and OUTPUT CONNECTIONS. Do not operate the amplifier without speakers or equivalent loads connected exactly as described. Set the SELECTOR switch to the corresponding phono position (PH. A or PH. B) and the MODE switch to STEREO. Play a known high quality stereo recording on the phonograph. If there is no output to the speaker, or if the output is low or audibly distorted, proceed to the checks for those symptoms. If there is excessive hum in the output, disconnect the phono input cable from the amplifier and short the phono input jack to chassis. If the hum disappears, the trouble is not in the amplifier but in the phonograph or in the connection to the amplifier. In each case, check for the trouble in the amplifier which seems defective. If both amplifiers are defective, check the power supply.

Excessive hum on other inputs may be checked in a similar manner. Disconnect the input cable in question and short the particular input jack to the chassis. If the hum disappears, the trouble is external to the amplifier. Note that on all inputs, the braid of the input cable should connect to the amplifier only through the skirt of the input connector. The cause and remedies for the following symptoms are then based on the assumption that checks made in the manner described above have eliminated the possibility of the trouble being external to the amplifier.

If trouble is no output or low output, check AC signal voltages and DC operating voltages starting at the input, and work step-by-step toward the output in each amplifier. Set the LEVEL control to maximum (10), the BALANCE, BASS and TREBLE controls to their mid-points (0), the SELECTOR switch to PH. A or PH. B and the MODE switch to STEREO. Feed a 1000 cycle sine-wave signal from an audio signal generator through a precision 100:1 attenuator to the phono inputs selected. The attenuator permits obtaining a level of 0.003 volt fed into MAG. PHONO from an audio generator output of 0.3 volts, which can easily be measured on

the lowest AC volts range of your VTVM (also improves signal to hum from generator). Use a high input impedance VTVM for all AC signal voltage measurements; a VTVM or 20,000 Ω /v VOM for DC volts measurements.

If the trouble is an excessively distorted output, try tube replacement, signal tracing, or proceed directly to voltage and resistance measurements.

When the defective stage is localized, proceed to a resistance and voltage check of the stage, using the data in the VOLTAGE and RESISTANCE chart. Disconnect the amplifier from the power line and discharge capacitors prior to making any resistance check, and prior to removing any or all of the 7591 output tubes. Do not turn the amplifier on with any of the output tubes removed.

TRANSFORMER TEMPERATURE

The transformers used in this unit run at a temperature less than 195°F despite the fact that the safety limit is at a much higher 221°F. Although 195°F is cool for a transformer, it is very hot to the touch. Transformers which seem too hot when touched with the hand, are usually good and are actually not overheating.

Output transformers usually run cooler than power transformers. Some output transformers may appear hotter

than others due to being located near hot components such as output and power tubes and power transformers.

SERVICE

If trouble develops in your instrument which you cannot remedy yourself, write to our service department listing all possible indications that might be helpful. List, also, any code numbers in red under the words INSTRUCTION MANUAL on the cover. If desired, you may return the instrument to our factory where it will be placed in operating condition for \$13.50 plus the cost of parts replaced due to their being damaged in the course of construction. NOTE: Before returning this unit, be sure all parts are securely mounted. Attach a tag to the instrument, giving your home address and the trouble with the unit. Pack very carefully in a rugged container, using sufficient packing material (cotton, shredded newspaper, or excelsior), to make the unit completely immovable within the container. The original shipping carton is satisfactory, providing the original inserts are used or sufficient packing material inserted to keep the instrument immovable. Ship by prepaid Railway express, if possible, to Electronic Instrument Co., Inc., 33-00 Northern Blvd., Long Island City 1, New York. Return shipment will be made by express collect. Note that a carrier cannot be held liable for damages in transit if packing IN HIS OPINION, is insufficient.

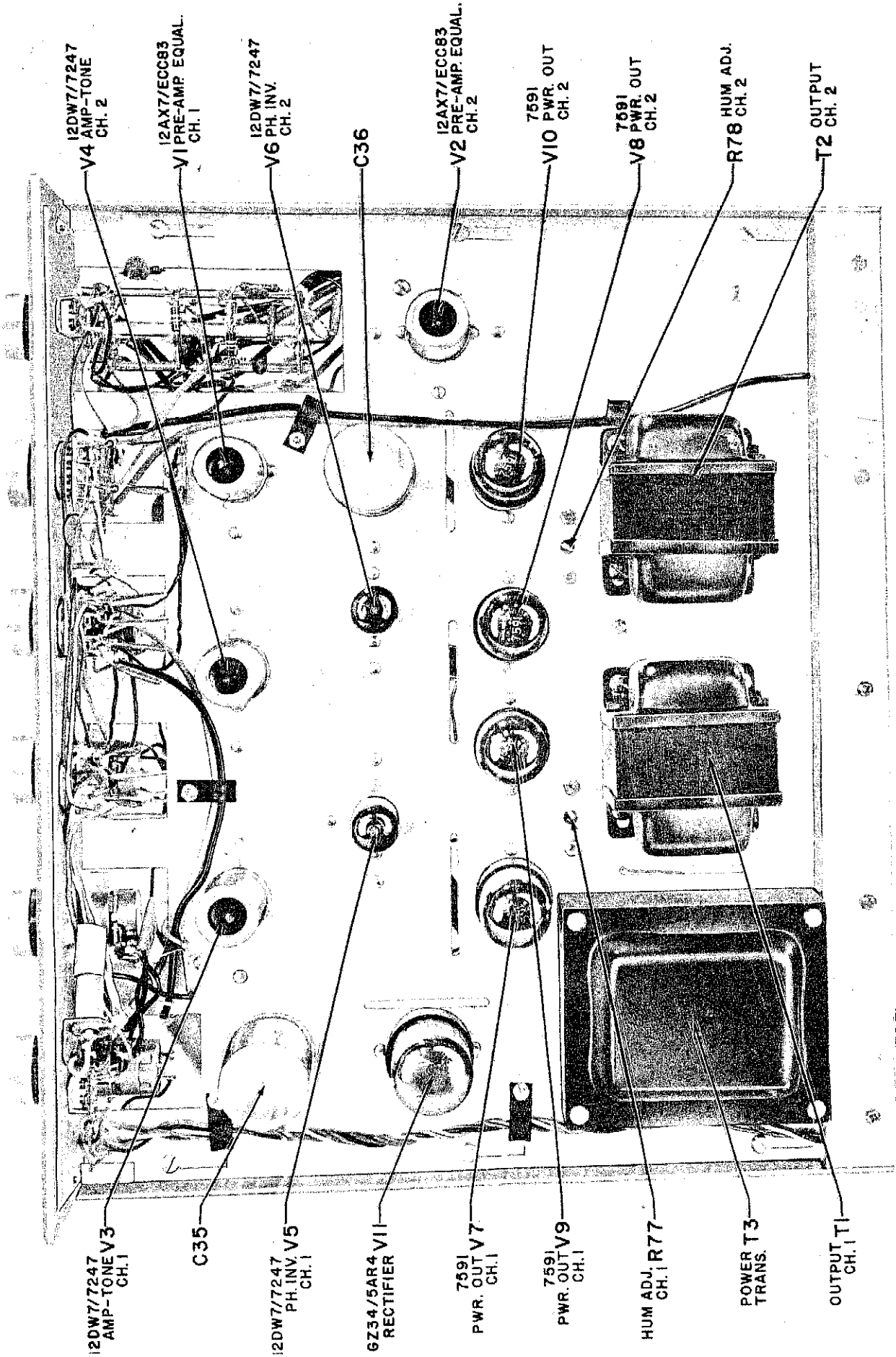

TUBE LAYOUT FIGURE 3

TROUBLE-SHOOTING CHART

SYMPTOM	CAUSE	REMEDY
Amplifier causes power line fuse to blow. Power line fuse blows again with V11 out of its socket.	Line cord, J16, primary or high voltage secondary windings of T3 shorted internally or externally (wiring).	Replace or repair.
Amplifier causes power line fuse to blow. Power line fuse does not blow again with V11 out of its socket.	Defective V11, C35, V7, V8, V9, V10; T1 or T2 primary shorted internally or externally.	Replace or repair.
Any or half of tube filaments not lit.	Open tube filament. Open lead from one of the 6.3V windings of T3. One 6.3V winding of T3 open.	Replace or repair.
Output tube bias too high (resulting in distorted output waveform).	Open R73, R74.	Replace or repair.
DC voltage at V11, cathode (pin 8) is incorrect as specified below. a) No voltage. b) High voltage. c) Low voltage.	Defective V11. C35 shorted internally or externally. Connection from C35 to pin 8 of V11 is broken. Connection to center tap of h.v. secondary winding of T3 open. Output tubes, V7, V8, V9, V10 over-biased or not drawing current. May result from open R73, R74. Excessive current drain in amplifier. Defective V11	Replace Replace or repair. Repair Check possible causes and replace or repair. Check possible causes and repair. See trouble-shooting typical stage. Replace
Excessive hum on mag. phono tape head or mic.	V1 or V2 defective Fil. leads dressed too close to grid lead. Tube shield not making electrical contact to base or base not making electrical contact to chassis. Shielding and grounding of wiring to input jacks not exactly as instructed and shown in drawings.	Replace Dress fil. leads away from grid lead. Check and correct. Correct.
Excessive noise on mag. phono or tape head.	V1 and V2 and contacts dirty.	Clean thoroughly with carbon tetrachloride.
Sustained oscillations.	Poor dress of output transformer T1 or T2 leads.	Dress all input leads and T1, T2 leads away from each other. Keep T1, T2 leads away from input jacks.
Sustained microphonics on mag. phono, tape head or mic.	V1 or V2 defective.	Replace
Hum on all inputs	V3 or V4 defective, not properly shielded, or dirty sockets and contacts. Dress of power transformer T3 leads.	Replace, correct, or clean. Correct

REPLACEMENT PARTS LIST

SYMBOL NO.	STOCK NO.	AMT.	DESCRIPTION	STOCK NO.	AMT.	DESCRIPTION
C1, 2	22538	2	cap., disc, 600mfd, 10% .4mf	40000	47	nut, hex, 6-32
C3, 4	22520	2	cap., disc, 1000mfd (1.2K or 1200mfd), 10%	40001	6	nut, hex, 3/8-32
C5, 6	22522	2	cap., disc, 360mfd, 10%	40007	48	nut, hex, 4-40
C7, 8, 9, 10	22517	4	cap., disc, .025mfd (25K or 25,000mfd), GMV	40008	12	nut, hex, 8-32
C11, 12	22534	2	cap., disc, 68mfd, 10%	40016	1	nut, 1/2" for fuseholder
C13, 14	22580	2	cap., disc, .2mfd, +80-20%	41003	8	screw, 8-32 x 3/8
C15, 16, 17, 18, 19, 20, 21, 22	20039	8	cap., molded, .1mfd, 400V	41035	5	screw, #6 x 1/4, self tapping
C23, 24	22547	2	cap., disc, .015mfd (15K or 15,000mfd), 20%	41047	7	screw, #8, self tapping
C25, 26	22532	2	cap., disc, .0015mfd (1.5K or 1500mfd), 10%	41086	47	screw, 6-32 x 5/16
C27, 28	22523	2	cap., disc, .0068mfd (6.8K or 6800mfd), 10%	41090	36	screw, 4-40 x 5/16
C29, 30	22548	2	cap., disc, .009mfd (9K or 9000mfd), 10%	41091	12	screw, 4-40 x 1/4, flat head
C31, 32	22547	2	cap., disc, .015mfd (15K or 15,000mfd), 20%	41026	2	screw, 4-40 x 1/4, brass
C33, 34	22509	2	cap., disc, 100mfd, 10%	41097	2	screw, 6-32 x 5/16, brown oxide
C35	24008	1	cap., elec., 40-20/500V	41099	18	screw, 8-32 x 3/8, Type F, brown oxide
C36	24005	1	cap., elec., 20/40/40-400/350/350V	41100	2	screw, 8-32 x 1 3/4
C37	23041	1	cap., elec., 30mfd, 400V	42000	6	washer, lock, #3/8
C38, 39	23007	2	cap., elec., 50mfd, 25V	42002	46	washer, lock, #6
C40	20043	1	cap., molded, .03mfd, 600V	42007	48	washer, lock, #4
C41, 42	22548	2	cap., disc, .009mfd (9K or 9000mfd), 10%	42005	2	washer, #6, flat
F1	91005	1	fuse, 3 amp	42008	12	washer, lock, #8
I1	92000	1	bulb, #47	42029	1	washer, rubber, 1/2" for fuseholder
J1, 2, 3; 4, 5, 6; 7, 8, 9; 10, 11, 12; 13, 14, 15	50018	5	jack, phono, triple	42055	2	washer, flat, #8, 5/8" OD
J16, 17	50016	2	A.C. receptacle	43000	1	lug, ground, #6
PC1, 2	29751	2	printed circuit	43004	5	lug, ground, #8
R1, 2	10428	2	res., 47K, 1/2W, 10% (yellow, violet, orange, silver)	46000	1	grommet, rubber, 3/8
R3, 4	10410	2	res., 100K, 1/2W, 10% (brown, black, yellow, silver)	46011	4	plastic feet
R5, 6, 7, 8	11526	4	res., 200K, 1/2W, 5% (red, black, yellow, gold)	53047	2	knob, concentric, inner
R9, 10	11532	2	res., 4M, 1/2W, 5% (yellow, black, green, gold)	53048	2	knob, concentric, outer
R11, 12	10407	2	res., 1M, 1/2W, 10% (brown, black, green, silver)	53049	4	knob, dual, split knurl
R13, 14	10424	2	res., 22K, 1/2W, 10% (red, red, orange, silver)	57000	1	line cord
R15, 16	11512	2	res., 2.4K, 1/2W, 5% (red, yellow, red, gold)	58004	length	wire, hook-up, black
R17, 18	10455	2	res., 1.5M, 1/2W, 10% (brown, green, green, silver)	58005	length	wire, hook-up, brown
R19, 20	11520	2	res., 40K, 1/2W, 5% (yellow, black, orange, gold)	58006	length	wire, hook-up, red
R21, 22	11533	2	res., 1.2K, 1/2W, 5% (brown, red, red, gold)	58007	length	wire, hook-up, orange
R23, 24, 25	10444	3	res., 120K, 1/2W, 10% (brown, red, yellow, silver)	58008	length	wire, hook-up, yellow
R26	10416	1	res., 15K, 1/2W, 10% (brown, green, orange, silver)	58009	length	wire, hook-up, green
R27, 28	11523	2	res., 68K, 1/2W, 5% (blue, grey, orange, gold)	58010	length	wire, hook-up, blue
R29, 30	10421	2	res., 6.8K, 1/2W, 10% (blue, grey, red, silver)	58012	length	wire, hook-up, grey
R31-32	18068	1	pot., 750K, dual	58013	length	wire, hook-up, white
R33-34	18069	1	pot., 250K, dual	58300	length	spaghetti, small
R35, 36	10413	2	res., 2.7K, 1/2W, 10% (red, violet, red, silver)	58303	length	spaghetti, large
R37, 38, 39, 40	11546	4	res., 33K, 1/2W, 5% (orange, orange, orange, gold)	58408	length	single conductor, black
				58412	length	cable, 3 conductor
				58414	length	cable, single conductor, grey

REPLACEMENT PARTS LIST (CONTINUED)

SYMBOL NO.	STOCK NO.	AMT.	DESCRIPTION	STOCK NO.	AMT.	DESCRIPTION
R41	10452	1	res., 8.2K, 1/2W, 10% (grey, red, red, silver)	58501	length	wire, bare
R42	14502	1	res., 1800Ω, 5W, 10%, W. W.	80092	1	panel
R43, 44	10442	2	res., 1.5K, 1/2W, 10% (brown, green, red, silver)	81175	2	cable clamp, plastic
R45-46	18071	1	pot., 1M, concentric	81270	1	input strip, rear panel
R47-48, 53	18070	1	pot., 500K, concentric with switch	81273	1	chassis hood
R49, 50	10431	2	res., 470K, 1/2W, 10% (yellow, violet, yellow, silver)	81275	1	bottom plate
R51, 52	10432	2	res., 1K, 1/2W, 10% (brown, red, black, silver)	81276	1	cable clamp - small
R53, 54	10431	2	res., 470K, 1/2W, 10% (yellow, violet, yellow, silver)	81920	6	clamp, cable - large
R55, 56	11510	2	res., 1.138K, 1/2W, 5%	81921	2	bracket, extrusion, left side rail
R57, 58	11556	2	res., 15K, 1/2W, 5% (brown, green, orange, gold)	81922	1	bracket, extrusion, right side rail
R59, 60, 61, 62	11547	4	res., 82K, 1/2W, 5% (grey, red, orange, gold)	81923	1	pilot light shield
R63, 64, 65, 66, 67, 68	10412	6	res., 330K, 1/2W, 10% (orange, orange, yellow, silver)	89537	1	shield for 9 pin socket
R69, 70, 71, 72	10400	4	res., 10K, 1/2W, 10% (brown, black, orange, silver)	97300	4	jewel for pilot light
R73, 74	14602	2	res., 125Ω, 5W, 5%, wire wound	97717	1	Manual of Instructions (Wired)
R75	14850	1	res., 16Ω, 20W, 5%, wire wound	66094	1	Manual of Instructions (Kit)
R76	11559	1	res., 12K, 1/2W, 5% (brown, red, orange, gold)	66347	1	
R77, 78	19016	2	pot., 100Ω, wire wound			
R79	14510	1	res., 33K, 5W, 10%			
S1	60074	1	switch, rotary, 4 sections			
S2	60083	1	switch, rotary, 1 section			
S3		1	switch, SPST mounted on R47, 48			
S4	62012	1	switch, slide, Double Pole Double Throw			
S5, 6, 7	62014	3	switch, slide, Four Pole Double Throw			
S8	62012	1	switch, slide, Double Pole Double Throw			
T1, 2	32020	2	transformer, output			
T3	30047	1	transformer, power			
TB1, 2, 3	54500	3	terminal board, 4 screw			
TB4	54002	1	terminal strip, 1P right with ground			
TB5, 6, 7, 8, 9, 10, 11, 12, 13	54003	9	terminal strip, 2 post			
TB14, 15	54006	2	terminal strip, 3 post 2 right			
TB16, 17, 18	54001	3	terminal strip, 1 post right			
TB19	54015	1	terminal strip, 3 post 2 left with ground			
TB20, 21, 22, 23, 24	54003	3	terminal strip, 2 post			
V1, 2	90034	2	tube, 12AX7/ECC83/7025			
V3, 4, 5, 6	90061	4	tube, 12DW7/7247			
V7, 8, 9, 10	90073	4	tube, 7591			
V11	90044	1	tube, GZ34			
X11	97712	1	pilot light assembly			
XF1	97800	1	fuseholder			
XV1, 2, 3, 4	97027	4	socket, 9 pin miniature with shield support			
XV5, 6	97025	2	socket, 9 pin miniature			
XV7, 8, 9, 10, 11	97032	5	socket, octal			

VOLTAGE AND RESISTANCE CHART

	Pin#	Column 1 DC volts at 20 watts each channel	Column 2 DC volts at no signal	Column 3 AC volts (signal) at .0023V into Mag. Phono Input	Column 4 Resistance in ohms. Pin 8 of XV11 grounded
V1,2	1	107	113	.275	75K
	2	0	0	.018	1.5Meg
	3	0.9	0.83	.01	1150
	4	15	14		125-175
	5	15	14		125-175
	6	38	41	.018	355K
	7	0	0	.0023	113K
	8	0.5	0.5	.0027	2300
	9	15	14		125-175
V3,4	1	54	50	0.86	81K
	2	0	0	0.135	250K
	3	1.75	1.83	0.058	1500
	4	15	14		125-175
	5	15	14		125-175
	6	75	78	0.73	83K
	7	0	0	0.064	320K
	8	.42	.45	0.037	1K
	9	15	14		125-175
V5,6	1	195	215	8.1	92K
	2	86	89	9.5	340K
	3	93	97	8.1	82K
	4	15	14		125-175
	5	15	14		125-175
	6	86	89	9.5	340K
	7	0	0	0.7	300K
	8	.6	.65	0.59	1.1K
	9	15	14		125-175
V7,8 V9,10	1	0	0	8.1	330K
	2	15	14		125-175
	3	395	396	220	170-210
	4	310	318	2.7	1800
	5	15	14	.05	125
	6	0	0	8.1	330K
	7	15	14		125-175
	8	310	318	.23	1800
V11	1				
	2	402	407		> 30K**
	3				
	4	335*	335*		20-35
	5				
	6	335*	335*		20-35
	7				
	8	402	407		> 30K**

*AC 60 cycles

**Short from pin 8 of XV11 to ground removed

Note: Throughout voltage checks, a dummy load must be connected across each amplifier output.

Column 1 - Feed a 1kc signal into TAPE/AUX. 1 input. Set ST-40 controls as follows: SELECTOR switch at TAPE/AUX., MODE switch at MONO 1, BALANCE control at 0, LEVEL control at 10, BASS controls at 0, TREBLE controls at 0, and all slide switches to the down (off) position. Adjust audio generator output for 20 watts output each channel.

Column 2 - Remove input signal. Use same control settings as in/Column 1.

Column 3 - AC signal voltages checked one channel at a time. To test Channel 1 amplifier, feed a .0023 volt, 1kc signal from an audio generator to the PH. A1 input. Set SELECTOR switch at PH. A, MODE switch at ✓CH. 1, and all other controls as given for Column 1. To test Channel 2 amplifier, feed a .0023 volt, 1kc signal to the PH. A2 input and set the MODE switch at ✓CH. 2.

Column 4 - Set controls as for Column 1. Disconnect unit from AC line and remove all input and output connections. Short pin 8 of XV11 to chassis ground with a jumper throughout resistance measurements, except when resistances at XV11 pins are being checked.

The reference designation assigned to receptacles (often referred to as jacks) is the letter J. The different types of jacks and plugs used in this kit are so lettered and illustrated here as well as in the construction steps. In some cases, three jacks are mounted on one bakelite strip and are so noted.

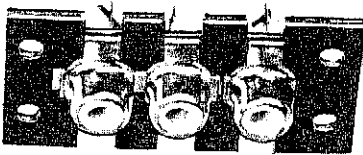

TRIPLE
PHONO
JACK

AC
RECEPTACLE

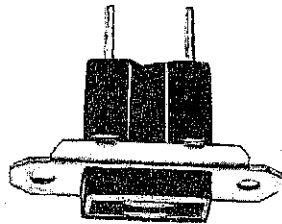

In some cases, these jacks are insulated from the chassis. A bakelite insulator used between the chassis and the jack is supplied for this purpose.

The reference designation assigned to capacitors is C.

Some capacitors, such as electrolytics, are marked plus (+) and minus (-). These are the only capacitors that must be mounted in a specific direction. Follow the direction for mounting described in the appropriate steps below. When no direction is mentioned, mount the capacitor either way. Some molded paper capacitors have a black line near one end. Although these can be mounted without any concern for direction, it is preferable that you follow the direction for the black line shown on the drawing. If there is no black line on the drawing or on the capacitor, just mount the capacitor in either direction.

The peak or working voltages are important capacitor characteristics. A capacitor marked with a higher voltage may be substituted for a lower voltage unit. Thus, a 1000 volt capacitor may be used in place of a 500 volt unit. The reverse is obviously not true. You cannot use a 500 volt unit as a substitute for a 1000 volt capacitor. Where more than one capacitor of identical value but different breakdown voltages are used, the unit you are to use is indicated in the appropriate construction step.

Ceramic capacitor tolerance may be noted by a letter rather than a number. "K" is 10%. "M" is 20%, "P" or "GMV" means guaranteed minimum value.

Ceramic capacitors have specific temperature characteristics — percent and degree of variation of cap-

acity with temperature. These variations are indicated by means of a code number stamped on most capacitors. Thus, a capacitor marked 68 Z5E indicates a 68mmf capacitor having a Z5E temperature characteristic. The actual meaning of Z5E, or any other characteristic, is important to the engineer. When building the kit, be sure to use the capacitor with the characteristic specified by the engineer, if it is indicated in the construction steps. If no value is indicated in the construction book, use any of the ceramic capacitors of proper value, tolerance and voltage characteristics, supplied with the kit.

Resistors are denoted by the symbol letter R.

Some resistors have their resistance value stamped on the surface of the resistor body. However, other fixed resistors are coded with color bands which indicate their value. The actual color code of these resistors is noted in the parts list. In some instances, even when the color code is noted, in the book, the actual resistor value may be stamped on the body, rather than the color code.

The tolerance of a resistor is the amount the resistance can vary around its marked value. Thus, if a 1K Ω (1000 ohms) resistor has a $\pm 10\%$ tolerance, its actual value can be between 900 ohms and 1100 ohms. If the same resistor has a $\pm 5\%$ tolerance, its actual value can be between 950 ohms and 1050 ohms. The fourth color band from the end of the resistor, indicates the tolerance. The gold band indicates a 5% tolerance, the silver band a 10% tolerance and the absence of a band a 20% tolerance. This tolerance value is always stated or given as part of the color code when the resistor is listed. If the resistor is marked with a number rather than a color code, the tolerance, is stamped on the body. In your kit, 5% resistors may be substituted for 10% and 10% resistors substituted for 20%. However, be certain that you do not use a 10% resistor when a 5% resistor is required or a 20% resistor when a 10% or 5% resistor is specified.

Resistors are capable of dissipating power. Large resistors handle more power while smaller ones handle less. A 1/2 watt resistor is usually smaller than a 1 watt unit, while a 1 watt resistor is usually smaller than a 2 watt unit. If like valued resistors are used in the kit, differing in power rating, the proper resistor to use is designated in the particular construction step.

Besides the fixed resistors discussed, there are also variable resistors known as potentiometers. They may be equipped with shafts on which a control knob may be mounted. The potentiometer combinations R31-R32 and R33-R34, are both dual pots controlled by one shaft. R45-R46 and R57-R48 are dual pots each con-

trolled by their individual concentric shafts. In addition, the power switch, S3, is mounted on the rear of potentiometer R48 and is activated by the same shaft (inner concentric), which varies the resistance of R48.

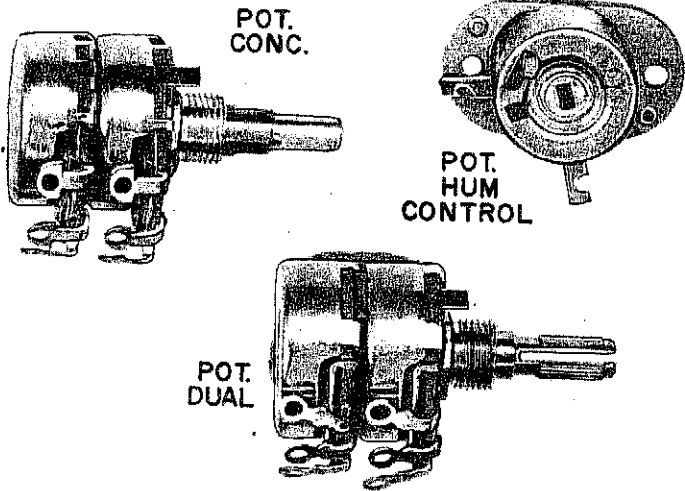

Other variable resistors may each have a short shaft with a slotted end or simply a slot in the variable element, requiring a small screwdriver for adjustment. This latter type is generally used for infrequently made adjustment, such as for the hum controls in the ST-40.

TERMINAL STRIPS

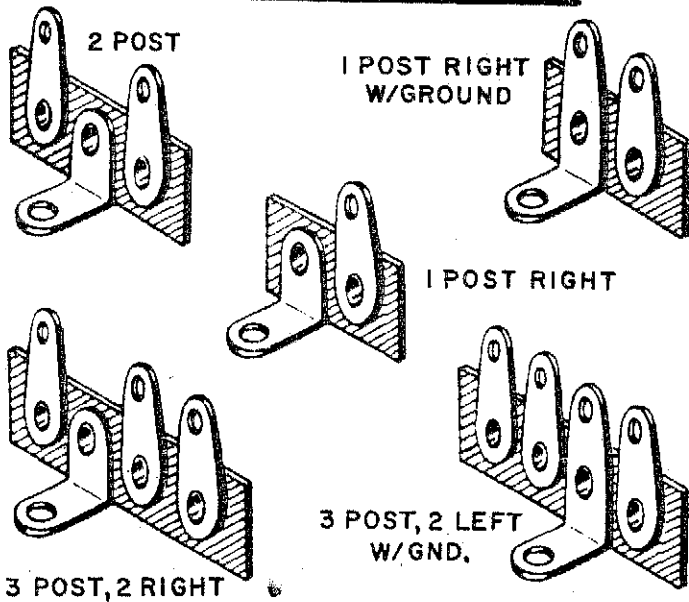

The various types of terminal strips are assigned the designation letters TB. The types used in this kit are illustrated and denoted in this figure.

TERMINAL BOARD, 4 SCREW

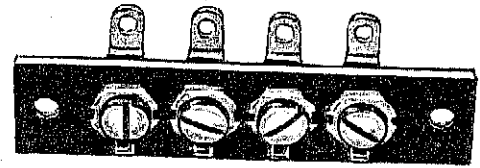

Switches are designated by the letter S. S1 refers to the switch assigned number 1, S2 refers to the switch assigned number 2. Switches may take several forms. In the ST-40, the rotary switches have been assigned numbers S1 and S2, the slide switches have been assigned numbers S4, S5, S6, S7 and S8. The power on-off switch mounted on the rear of the treble control potentiometer R47 and R48, has been assigned number S3. Each lug on the slide switches has been assigned a number. Thus S5-3 refers to lug #3 on slide switch S5.

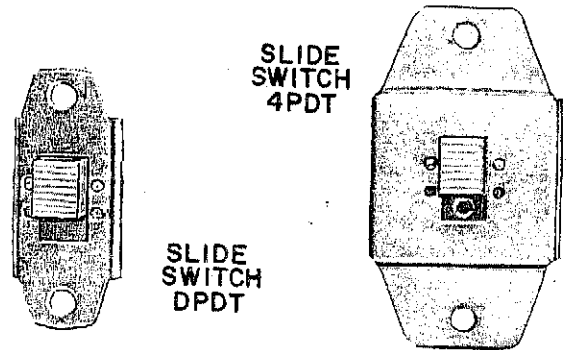

Turn the rotary switches to the maximum counter-clockwise position. The exact position of the lugs referred to are determined by looking at the switch for the view shown in the figure.

On rotary switches, the front of the wafer is assigned one letter of the alphabet and the rear a second letter. If there is more than one wafer (such as is the case for S1 illustrated in the construction steps), the sides of the wafers are assigned more letters in sequence. Thus the front of the second wafer is assigned letter "C" while the rear of the wafer has been assigned letter "D". In the single wafer switch shown S2A-11 refers to switch S2, the front side of the wafer, solder lug #11.

Hardware is a general term for mechanical parts used in the assembly of EICO kits. Such items are usually screws, nuts and washers. Machine screws are sized in accordance with the diameters of the threaded portion (#4, #6, #8,) with the smaller number denoting the smaller diameter. The second number indicates the number of threads to an inch. Thus, a #6-32 screw has a #6 diameter with 32 threads per inch. The final number indicates the length of the threaded portion. A #6-32 x 3/8 has a 3/8" long threaded portion. The diameters are shown in the figure.

HARDWARE

ACTUAL SIZE OF DIAMETERS

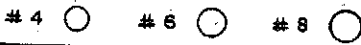

SCREWS

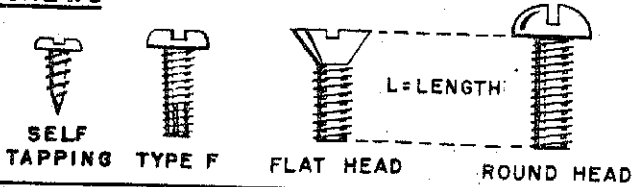

EXAMPLE

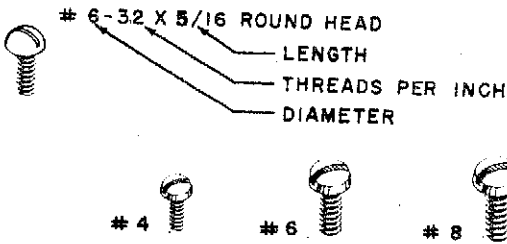

WASHERS

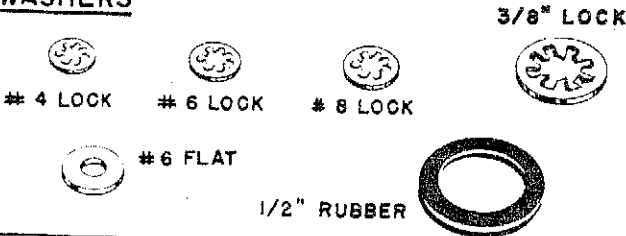

NUTS

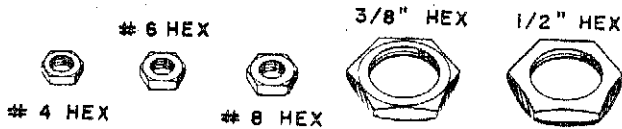

LUGS



MISCELLANEOUS

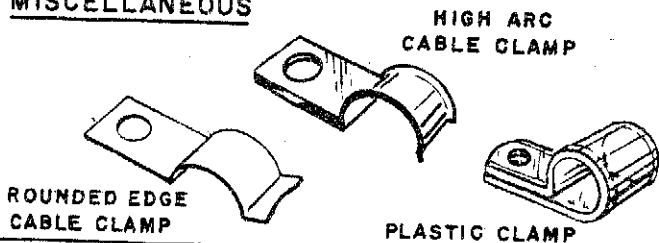

The figure also shows the various head types in which these screws are supplied. Use the type specified in the particular step.

Washers and nuts are sized in accordance with the diameter of the screws they are used with.

Various types of washers are supplied. A lock-washer may have internal or external teeth. A flat washer is made out of flat metal. Fiber and bakelite

washers are used for insulating devices. They generally separate two metallic pieces of hardware. Tinnerman speed nuts are generally used to mount a chassis cover or bottom plate.

Self tapping screws are used where it is not desirable to hold the screw to the chassis by a nut. The screw actually taps the threads in the metal into which it is screwed. The sizes are designated by numbers similar to those used for machine screws, with the smaller number indicating a smaller diameter screw.

Grommets are rubber devices used for insulating wire from the metal chassis.

Most of the other component parts used with the kit are self evident and require little further explanation or description.

If after having checked all your components against the parts list, you find a shortage, please write us at:

Customer Service
Electronic Instrument Co., Inc.
33-00 Northern Blvd.
Long Island City 1, N.Y.

Include the inspection slip, with your letter, describing the shortage. If there is a slight hardware shortage, you can expedite matters by purchasing these pieces at your local jobber or hardware store.

Soldering Techniques: To get a good, clean connection, use the soldering techniques described below. USE THE BEST GRADE OF ROSIN CORE RADIO SOLDER ONLY. UNDER NO CIRCUMSTANCES SHOULD ACID CORE SOLDER OR ACID FLUX BE USED. The use of acid core solder or acid fluxes can cause serious corrosion and will void all the repair and service guarantees.

The soldering and wiring techniques described below should be practiced several times by the novice before he attempts to wire or solder components in the actual kit. Practice several connections with a spare piece of wire and a socket or terminal strip that can be purchased at your local jobber.

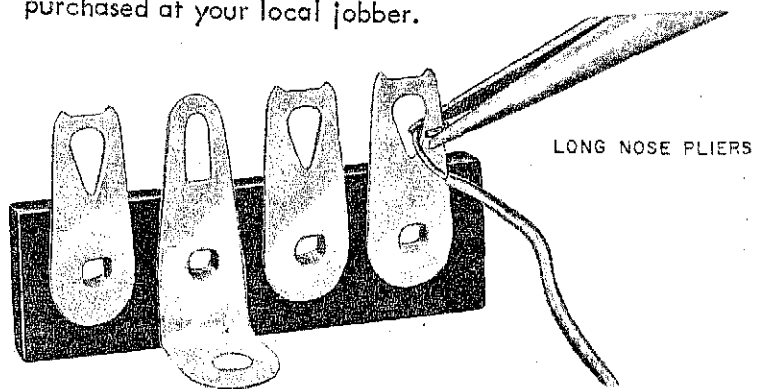

A. CRIMP LEAD TO TERMINAL FOR GOOD CONNECTION

First make a good mechanical connection. Remove $1/4$ " of insulation from the end of the wire. Feed the wire through the solder lug opening so that the wire insulation just touches the lug. With the long-nose pliers, bend the wire lead around the lug and crimp the wire lead to the lug. Now solder this wire. Place the tip of the hot soldering iron on the lug or terminal at a point close to the wire being soldered. Apply the solder to the junction of the lug, wire and soldering iron. When the lug and wire have been heated sufficiently, the solder will flow into and over the joint. Remove the iron when the solder starts to flow and remove the solder immediately after. Use only enough solder to cover the wire at the connection point.

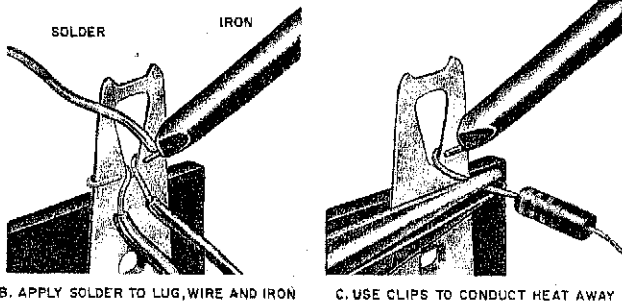

B. APPLY SOLDER TO LUG, WIRE AND IRON

C. USE CLIPS TO CONDUCT HEAT AWAY

A poor solder connection is obviously, its appearance. A grainy or pitted joint is a poor connection due to insufficient heat. Blobs of solder on the wire or solder lug is also due to insufficient heat. Solder should flow as a result of the heated lug and wire. Do not solder by applying solder to the iron tip and then wiping the hot solder onto the joint. A well soldered joint is indicated by a smooth shiny finish on the soldered connection.

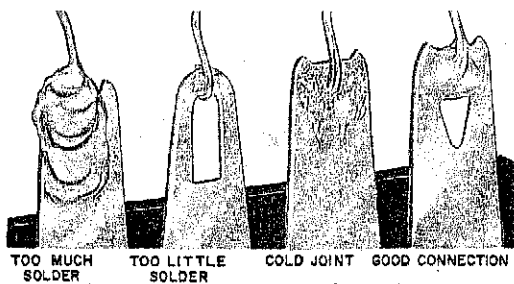

D. TOO MUCH SOLDER TOO LITTLE SOLDER COLD JOINT GOOD CONNECTION

Construction Hints: The various lengths of wire to be used in the kit are specified in the construction steps. After cutting the wire to the length specified, strip the insulation off $1/4$ " from each end. The exposed wire will be used to make the actual connection to the solder lug.

Shielded wire sizes are also indicated in the specific construction step. In the particular step you will be told just how much of the outer insulation must be removed and just how long the shield strands and inner conductor (s) must be.

Components, such as resistors, capacitors, transformers, etc., may have longer leads than specified. Cut the leads to the length indicated in the particular step. This length is to be measured from the body of the component. In the case of insulated leads, strip $1/4$ " of insulation off from the ends and twist the strands (if any) of the wire together.

As an example, one step may specify that each lead on a resistor be cut to $1/2$ ". $1/4$ " of each lead is used to make a mechanical connection to the solder lug. The other $1/4$ " is between the socket and the component so that the component will not be overheated when soldering.

When a connection is indicated, a (C) or an (S) will appear next to the lug involved. The (C) indicates that the connection should be made mechanically, but is not to be soldered yet, since other leads are to be connected to this same lug. The (S) indicates that the connection should be made and soldered immediately. However, the (S) is always followed by a number, such as (S1), (S2), (S3), etc. This number indicates the number of connections made to the lug. It is a check on the accuracy of your work.

As an example, if it says (S3), you should count three leads going to the lug to be soldered. If there are less than three leads at this particular lug, you will know that you have forgotten one or more leads, or connected them to the wrong lugs. If there are more than three leads, you can be certain you have connected an extra wire to this lug, which should probably go elsewhere.

When you assemble the components in your unit, mark the symbol number of each socket and terminal strip near the part with a crayon. This will facilitate your wiring operation.

When wiring, lay the component in close to the chassis, dress as shown in the drawing. Be careful to avoid shorts at the lugs. The book is written so that the wiring closest to the chassis usually gets wired in first. The next layer of wires are to be soldered in next. In each case, dress the leads and components as close to the chassis as possible.

Next to each step number you will find a parenthesis (). After you have completed each step, make a check mark in the parenthesis so that you will have a record of your work. Follow the steps in the sequence given in the book. Do not skip steps or pages.

If any addenda are included in your book to modernize your instrument or make corrections or part substitutions, be sure to correct the Construction Book first before you start to wire or assemble your kit.

You are now ready to construct your fine stereo dual power amplifier.

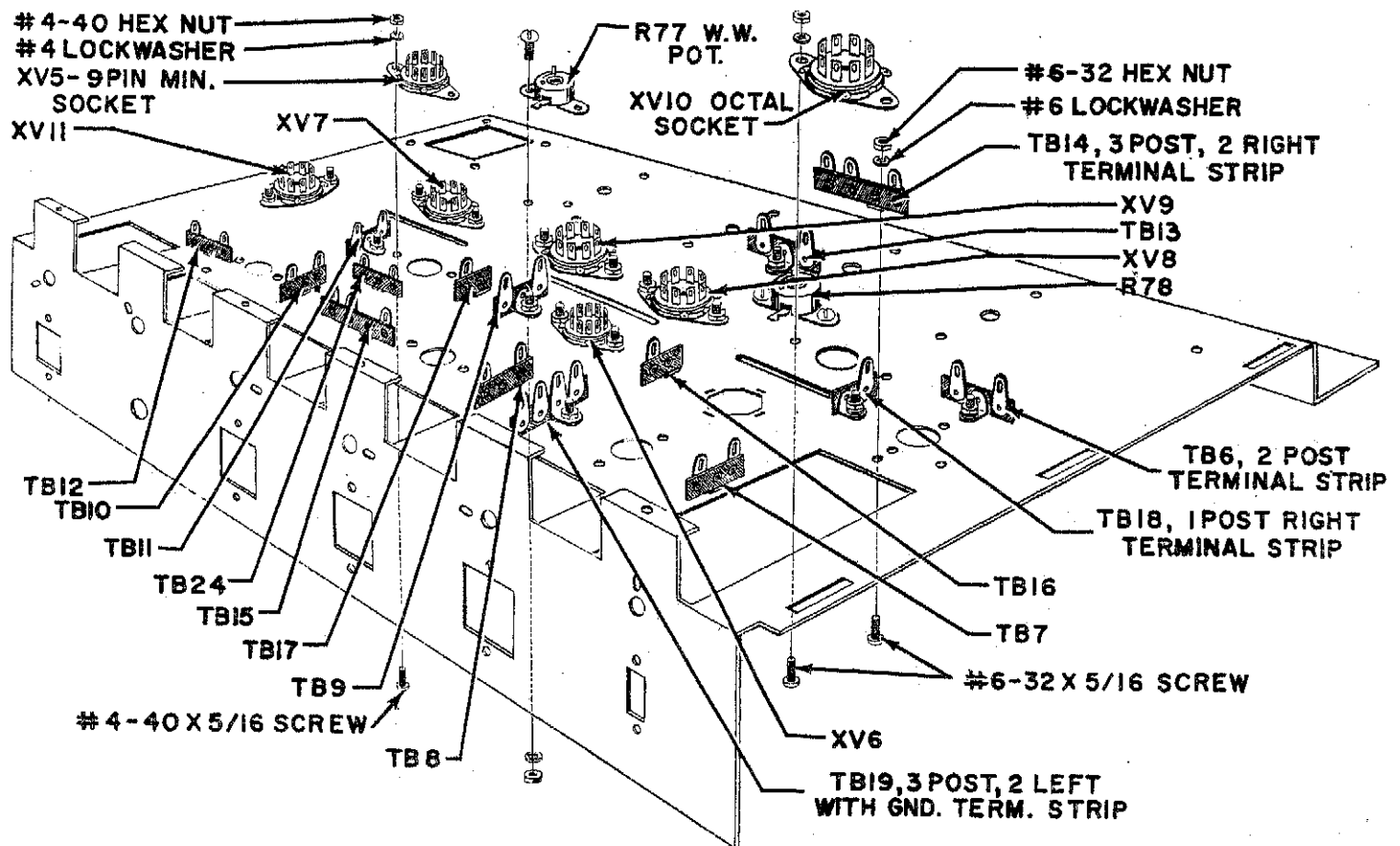

CHASSIS ASSEMBLY FIG. 1

The following steps refer to figure 1.

Place the chassis on the workbench in the position shown in the drawing. The surface of the chassis facing up towards you will be referred to as the bottom, while the surface laying against the workbench is the top. The front of the chassis has the six rectangular cutouts while the rear of the chassis has only one rectangular cutout at the left corner. Orient component as shown in Fig. 9 (fold-out).

1. Mount octal socket XV10 on the bottom near the right hand side of the chassis, as shown. Note the orientation of the center key in Figure 9. Use two #6-32 x 5/16 screws, two #6 lockwashers and two #6-32 hex nuts.
2. Similar to the above, mount octal sockets XV8, XV9, XV7 and XV11. Note the orientation of the center keys in Figure 9. Use two #6-32 x 5/16 screws, two #6 lockwashers and two #6-32 hex nuts to secure each socket to the chassis.
3. Mount the 9 pin miniature sockets without

shield supports XV5 and XV6, in the center of the chassis. Note the orientation of the pins in Figure 9. Use two #4-40 x 5/16 screws, two #4 lockwashers and two #4-40 hex nuts to secure each socket to the chassis.

4. Mount the nine 2 post terminal strips TB6, TB7, TB8, TB9, TB10, TB11, TB12, TB13 and TB24; the two 3 post 2 right terminal strips TB14 and TB15, the three 1 post right terminal strips TB16, TB17 and TB18; and the 3 post 2 left with ground terminal strip TB19; to the bottom of the chassis as shown. Observe the orientation of each terminal strip drawn in Figure 9. Use one #6-32 x 5/16 screw, one #6 lockwasher and one #6-32 hex nut to secure each terminal strip to the chassis.
5. Mount the miniature wire wound adjustment pots, R77 and R78, to the bottom of the chassis, as shown. Note the orientation of each pot in Figure 9. Use two #4-40 x 5/16 screws from below the chassis and two #4 lockwashers and two #4-40 hex nuts from above the chassis on each pot. Do not short the screws to the solder lugs on the pots.

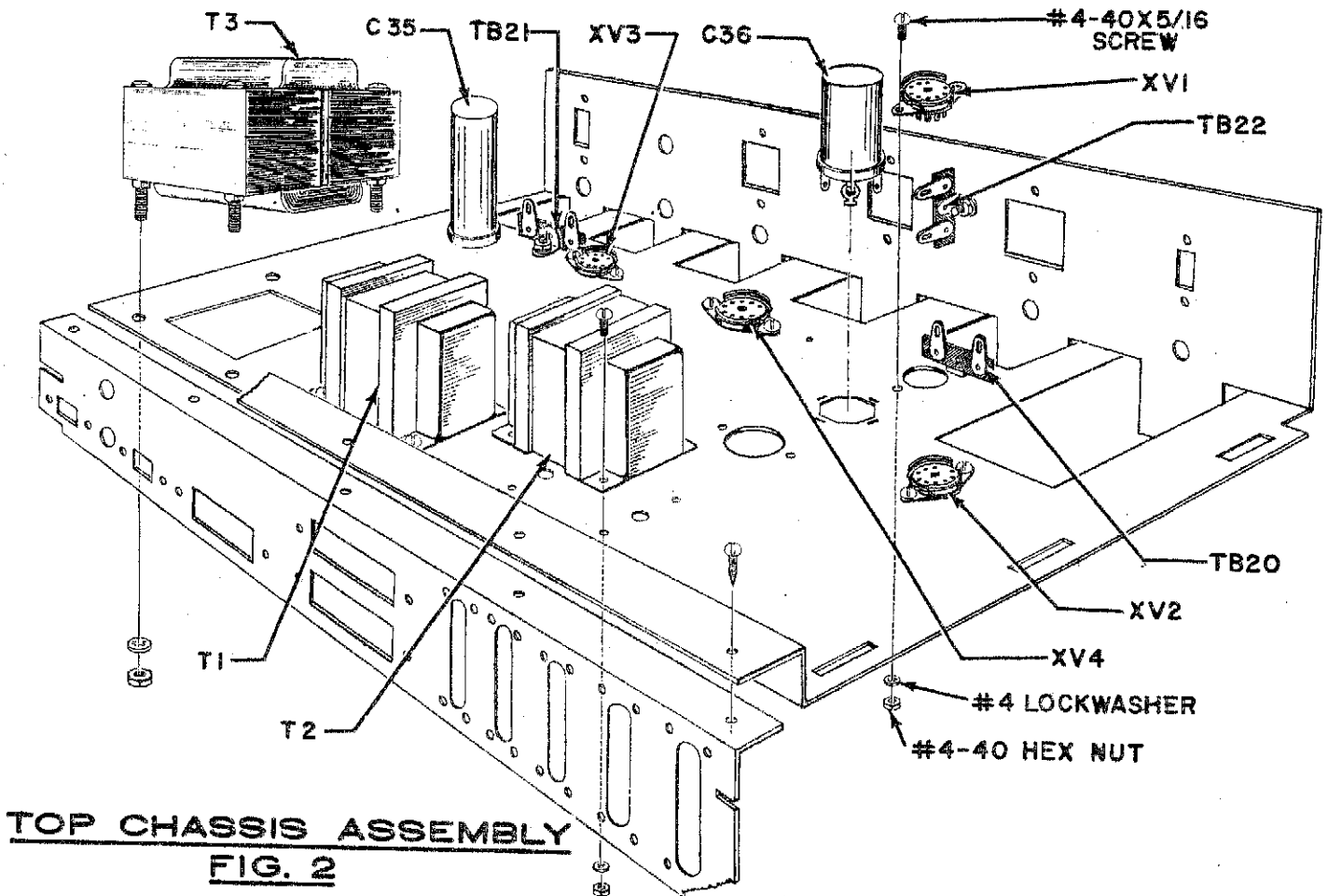

TOP CHASSIS ASSEMBLY
FIG. 2

The following steps refer to figure 2.

In this drawing, the chassis shown in Figure 1 has been turned over. The top of the chassis is now up towards you, while the six rectangular cutouts and the front panel with other cutouts are away from you. The mounting of the rear panel is shown in the drawing, but will not be completed at this time. The transformer mountings are also shown in this drawing, but will be completed later.

1. Mount the two 2 post terminal strips, TB20 and TB21, to the top of the chassis using one #6-32 x 5/16 screw, one #6 lockwasher and one #6-32 hex nut, on each. Mount the two post terminal strip, TB22 to the front panel on the chassis using one #4-40 x 1/4 flat head screw, one #4 lockwasher and one #4-40 hex nut.
2. Mount the four 9 pin miniature sockets with shield support, XV1, XV2, XV3 and XV4 from above the chassis, as shown. Noting the pin numbers stamped next to each solder lug in the mold. Orient the sockets as shown in Figure 9. Secure

each socket to the top of the chassis using two #4-40 x 5/16 screws, two #4 lockwashers and two #4-40 hex nuts.

3. Mount the 40/20mfd, 500V electrolytic can capacitor, C35, to the top of the chassis as shown. Next to one lug is a triangle and next to the second lug is a semicircle. Orient the capacitor so that the triangle and semicircle appear at the respective locations as shown in Figure 9. Insert the capacitor mounting tabs into the slots in the chassis and twist the tabs a little less than a quarter turn. Do not twist the tabs excessively or they will shear off. Solder the capacitor tab without a hole, to the chassis at the slot in the chassis.
4. Mount the 20/40/40mfd, 400/350/350V electrolytic can capacitor, C36, to the top of the chassis as shown. Next to one lug is a half moon (semicircle), next to a second lug is a square and next to the third lug is a triangle. Orient the capacitor and secure as in previous step.

REAR PANEL ASSEMBLY AND WIRING

The following steps refer to figure 3.

The rear panel consists of a long "U" shaped channel with numerous cutouts, to mount the various components. There are two flanges running along the length of the panel. The wide flange is considered the bottom in this drawing and the narrow flange is the top. When the following steps refer to the front of the mounting panel, it is describing an assembly operation concerning the side of the panel facing you in the drawing. The rear of the panel faces away from you, in the drawing. Note that the flanges are towards you. To avoid confusion, hold the panel as shown in the drawing.

- (✓) 1. Mount the triple input jack, J4, 5, 6, to the panel. Orient the jack so that the small solder lugs 2 and 5 are as shown. Place a triple jack insulator between the front face of the panel and the jack. Secure the jack and insulator to the panel using four #4-40 x 5/16 screws, four #4 lockwashers and four #4-40 hex nuts.
- (✓) 2. Similar to the above, mount triple input jacks J1, 2, 3; J7, 8, 9; J10, 11, 12; and J13, 14, 15. Orient all jacks so that the solder lugs are in the position equivalent to that shown for jack J4, 5, 6. Place a triple jack insulator between each jack and the front face of the panel. Secure each jack and insulator combination to the panel using four #4-40 x 5/16 screws, four #4 lockwashers and four #4-40 hex nuts.
- (✓) 3. Mount the four screw terminal board TB3 to the rear of the panel, as shown. Secure the terminal board to the panel using two #6-32 x 5/16 screws and two #6-32 hex nuts. Under one hex nut, place a #6 ground lug. Under the second hex nut, place a one post right with ground terminal strip TB4 and a #6 lockwasher.
- (✓) 4. Similar to the above, mount four screw terminal boards TB1 and TB2 as shown. Use two #6-32 x 5/16 screws and two #6-32 hex nuts to secure each terminal board to the panel. Under each nut used for securing TB2, place one #6 lockwasher. Under one nut used for securing TB1, place one lockwasher and under the second nut place the two post terminal strip TB5 and one lockwasher. The lockwasher in the latter case is directly under the nut, while TB5 is against the panel.

- (✓) 5. Mount the AC receptacle J16 to the front of the panel as shown. Use two #6-32 x 5/16 screws, two #6 lockwashers and two #6-32 hex nuts.
- (✓) 6. Similar to the above, mount AC receptacle J17. Use two #6-32 x 5/16 screws, two #6 lockwashers and two #6-32 hex nuts.
- (✓) 7. Mount the fuseholder XF1 to the rear of the panel, as shown. Use a thin rubber washer between the fuseholder mounting flange and the panel. Secure the fuseholder to the panel using a 1/2"-32 hex nut. Do not tighten too much or the holder will crack.
- (✓) 8. Push a rubber grommet in the remaining hole in the rear panel, under the fuseholder.

The following steps refer to figure 4.

- (✓) 1. Connect a 2 1/2" piece of black wire from J4, 5, 6-2 (C) to J4, 5, 6-5 (C).
- (✓) 2. Connect a 2 1/2" piece of black wire from J1, 2, 3-2 (C) to J1, 2, 3-5 (C).
- (✓) 3. Connect a 2 1/2" piece of black wire from J7, 8, 9-2 (C) to J7, 8, 9-5 (S1).
- (✓) 4. Continue by connecting a 2 1/2" piece of black wire from J10, 11, 12-2 (C) to J10, 11, 12-5 (S1).
- (✓) 5. Cut all leads on the two 47KΩ (yellow, violet, orange, silver) resistors R1, R2 to 1/2". Connect R1 from J1, 2, 3-2 (C) to J1, 2, 3-3 (C). Connect R2 from J4, 5, 6-2 (C) to J4, 5, 6-3 (C).
- (✓) 6. Cut all leads on the two 100KΩ (brown, black, yellow, silver) resistors R3, R4 to 1/2". Connect R3 from J1, 2, 3-4 (C) to J1, 2, 3-5 (S2). Connect R4 from J4, 5, 6-4 (C) to J4, 5, 6-5 (S2).
- (✓) 7. Cut an 11 1/2" length of 3 conductor shielded cable. On one end, strip back 1" of the outer insulation. Twist the shield threads together. Cut these strands to 1" and cover them with a 3/4" piece of thick spaghetti. Strip back the insulation 1/4" from the end of each of the inner conductors. Connect the twisted shield strands to J4, 5, 6-2 (S3), the orange lead to J4, 5, 6-1 (S1), the red lead to J4, 5, 6-3 (S2), and the brown lead to J4, 5, 6-4 (S2).

On the other end of the same shielded cable, strip back 1" of the outer insulation. Twist the shield strands together. Cut these strands to 1". Cover them with a 3/4" piece of thick spaghetti. Strip back the insulation 1/4" from the end of each of the inner conductors. This end of the cable does not get connected until later.

8. Cut a 13 1/2" length of 3 conductor shielded cable. On one end, strip back 1" of the outer insulation. Twist the shield strands together. Cut the shield strands to 1" and cover them with a 3/4" piece of thick spaghetti. Strip back the insulation 1/4" from the end of each of the inner conductors. Connect the twisted shield strands to J1, 2, 3-2 (S3). The orange lead to J1, 2, 3-1 (S1). The red lead to J1, 2, 3-3 (S2) and the brown lead to J1, 2, 3-4 (S2). On the other end of the same shielded cable, strip back 1" of the outer insulation. Twist the shield strands together. Cut these strands to 1". Cover them with a 3/4" piece of thick spaghetti. Strip back the insulation 1/4" from the end of each of the inner conductors. This end of the cable does not get connected until later.

9. Cut a 15 1/2" length of shielded 3 conductor cable. On one end strip back 1" of the outer insulation. Twist the shield strands together. Cut the shielded strands to 1" and cover them with a 3/4" piece of thick spaghetti. Strip back the insulation 1/4" from the end of each of the inner conductors. Connect the twisted shield strands to J7, 8, 9-2 (S2), the orange lead to J7, 8, 9-4 (S1), the red lead to J7, 8, 9-3 (S1), and the brown lead to J7, 8, 9-1 (S1).

On the other end of the same shielded cable, strip back 1 1/2" of the outer insulation. Twist the shield strands together. Cut these strands to 1 1/4". Cut the inner conductors to 1". Strip back the insulation to 1/4" from the end of each of the inner conductors. This end of the cable does not get connected until later.

10. Cut a 17 1/2" length of shielded 3 conductor cable. On one end strip back 1" of the outer insulation. Twist the shield strands together. Cut the shielded strands 1" and cover them with a 3/4" piece of thick spaghetti. Strip back the insulation 1/4" from the end of each of the inner conductors. Connect the twisted shield strands to J10, 11, 12-2

(S2), the orange lead to J10, 11, 12-4 (S1), the red lead to J10, 11, 12-3 (S1), the brown lead to J10, 11, 12-1 (S1).

On the other end of the same shielded cable, strip back 1 1/2" of the outer insulation. Twist the shield strands together. Cut these strands to 1 1/2". Cover them with a 1" piece of thick spaghetti. Strip back the insulation 1/4" from the end of each of the inner conductors. This end of the cable does not get connected until later.

11. On one end of a 17" piece of black single conductor shielded cable, strip the outer insulation back 1/2". Twist the shield strands together. Strip the insulation of the inner conductor back 1/4". Connect the twisted shield strands to J13, 14, 15-5 (S1). Connect the inner conductor to J13, 14, 15-4 (S1).

On the other end of the same piece of shielded cable, strip the outer insulation back 1 3/4". Twist the shield strands together. Cut the shield strands to 1 3/4" and cover it with a 1 1/2" piece of thick spaghetti. Cut the inner conductor to 1/2" and strip back the inner insulation to 1/4". This end will be connected later.

12. On one end of a 17" piece of grey single conductor shielded cable, strip the outer insulation back 1/2". Twist the shield strands together. Strip the insulation of the inner conductor back 1/4". Connect the twisted shield strands to J13, 14, 15-2 (C). Connect the inner conductor to J13, 14, 15-3 (S1).

On the other end of the same piece of shielded cable, strip the outer insulation back 1 1/2". Twist the shield strands together. Cut the shield strands to 1 1/2" and cover it with a 1 1/4" piece of thick spaghetti. Cut the inner conductor to 1/2" and strip back the inner insulation to 1/4". This end will be connected later.

13. On one end of a 17" piece of black single conductor shielded cable, strip the outer insulation back 1/2". Twist the shield strands together. Strip the insulation of the inner conductor back 1/4". Connect the twisted shield strands to J13, 14, 15-2 (S2). Connect the inner conductor to J13, 14, 15-1 (S1).

- Strip the insulation back 1/4" from each end of the inner conductor. Connect the inner conductor from the end without the shield strands to S1G-6 (S1). The other end will be connected later.
- (✓) 5. Connect a 3/4" piece of bare wire from SID-11 (C) to S1E-11 (S1).
 - (✓) 6. Connect a 1 1/2" piece of bare wire covered with a 1" piece of spaghetti from SID-12 (S1) to SID-1 (C).
 - (✓) 7. Connect a 2 1/2" piece of blue wire from S1B-12 (S1) to S1B-3 (C).
 - (✓) 8. Connect one end of a 4" piece of blue wire to SID-8 (C). The other end will be connected later.
 - (✓) 9. Connect one end of a 3 1/2" piece of green wire to SID-7 (S1). The other end will be connected later.
 - (✓) 10. Connect one end of a 4 1/2" piece of black wire to S1C-6 (C). The other end will be connected later.
 - (✓) 11. Connect one end of a 5" piece of brown wire to S1E-9 (C). The other end will be connected later.
 - (✓) 12. Connect one end of a 2 1/2" piece of orange wire to S1F-8 (S1). The other end will be connected later.
 - (✓) 13. Connect one end of a 2" piece of black wire to S1H-11 (C). The other end will be connected later.
- The five triple input jacks were previously mounted on the rear panel. Shielded wires were connected to these jacks. Place the panel near the switch S1, so that the jacks appear in the sequence shown in the drawing. See the mechanical layout of this in Figure 3 and the wiring in Figures 4 and 9.
- (✓) 14. From triple input jack J4, 5, 6 connect the shield strands from the remaining end of the shielded cable to S1H-11 (S3), the brown lead to S1H-8 (S1), the red lead to S1H-9 (S1) and the orange lead to S1H-10 (S1).
 - (✓) 15. From triple input jack J10, 11, 12, connect the shield strands from the remaining end of the shielded cable to S1F-6 (C), the brown lead to S1E-9 (S2), the red lead to S1E-10 (S1) and the orange lead to S1F-12 (S1).
 - (✓) 16. From the triple input jack J7, 8, 9, connect the shield strands from the remaining end of the shielded cable to S1C-6 (C), the brown lead to SID-8 (S2), the red lead to SID-9 (S1) and the orange lead to SID-10 (S1).
 - (✓) 17. On triple input jack J13, 14, 15, one end of a black shielded lead was connected to J13, 14, 15-4 and J13, 14, 15-5. Connect the shield strands from the other end to S1C-6 (C) and the inner conductor to SID-11 (S2).
 - (✓) 18. From the triple input jack J1, 2, 3, connect the shield strands from the remaining end of the shielded cable to S1A-10 (S3), the brown lead to S1B-7 (S1), the red lead to S1B-8 (S1) and the orange lead to S1B-9 (S1).
 - (✓) 19. You have now completed the prewiring of the switch. Mount the rear panel to the rear protusion on the main chassis using 5 #6 self tapping screws. See figures 2 & 9 for the orientation and mounting of the panel. Push the group of 5 twisted leads through hole "A" and the shield leads connected to J13, 14, 15-1 and J13, 14, 15-3 through hole "AA".
 - (✓) 20. Mount the switch just prewired, S1, on to the front panel. Orient the switch so that the locating lug fits into the elliptical hole adjacent to the mounting hole. Use a lockwasher between the switch and the panel. Secure the control to the panel using a 3/8" hex nut. See figure 6 to note the mechanical mounting. See figure 9 for the placement of the leads from the rear input jacks.
 - (✓) 21. Slip a plastic cable clamp around the wires connected to S1 and the input jacks. Position this clamp over the hole on the chassis near the input jacks. See Figure 9 for location. Put a #6 flatwasher on a #6-32x 5/16 screw and secure cable clamp to chassis with a #6 lockwasher and a #6 hex nut on the top side of the chassis.
 - (✓) 22. Similar to above, slip a second plastic cable clamp over the leads and secure to the chassis in the hole near XV2. See Figure 9. Use a #6-32x 5/16 screw, #6 flatwasher, #6 lockwasher and a #6 hex nut.

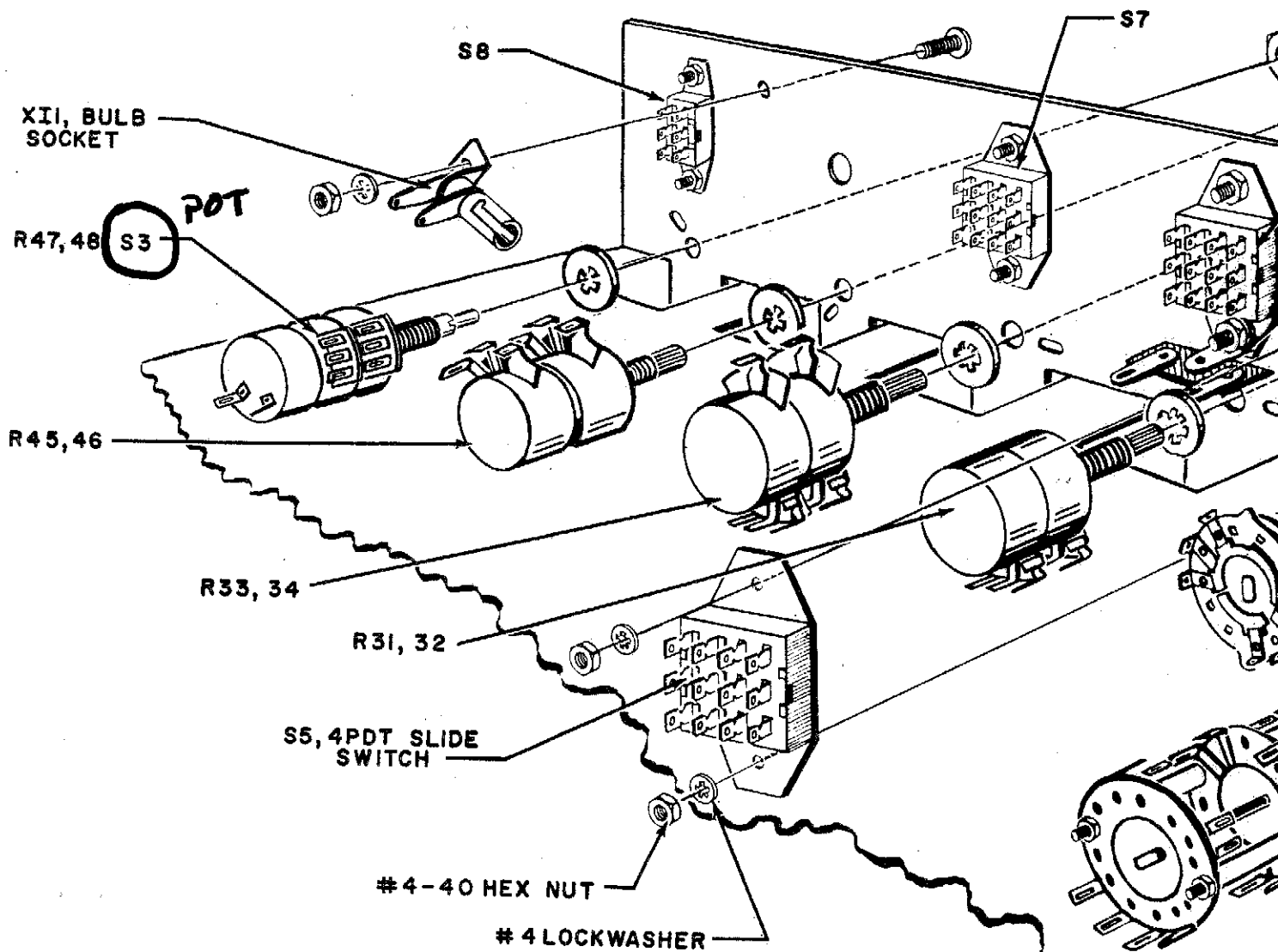

The following steps refer to figure 6.

In this figure, all components mounted to the front chassis panel are shown. Note that this is not the actual decorative and separate front panel which contains all the descriptive nomenclature. This panel is an integral part of the main chassis. Note that the view in the drawing is from the rear of the chassis. Switch S1 has already been mounted.

1. Mount the two DPDT slide switches, S4 and S8, as shown, in the rectangular holes closest to the two ends of the panel. Use two #4-40 x 1/4 flat head screws, two #4 lockwashers and two #4-40 hex nuts on each.
2. Mount the three 4PDT slide switches, S5, S6 and S7, as shown, in the remaining three larger

rectangular holes in the front chassis panel. Use two #4-40 x 1/4 flat head screws, two #4 lockwashers and two #4-40 hex nuts on each. On switch S6 mount the two post terminal strip, TB23, as shown.

3. Push the pilot light bulb into its socket XII and place the bulb shield over the bulb. Mount the pilot light assembly XII to the front panel using one #4-40 x 1/4 flat head screw, one #4 lockwasher and one #4-40 hex nut. Orient the socket so that the bulb is right opposite the round hole in the panel which is located midway between S7 and S8. Now, tighten the hex nut onto the screw holding the socket in this position.

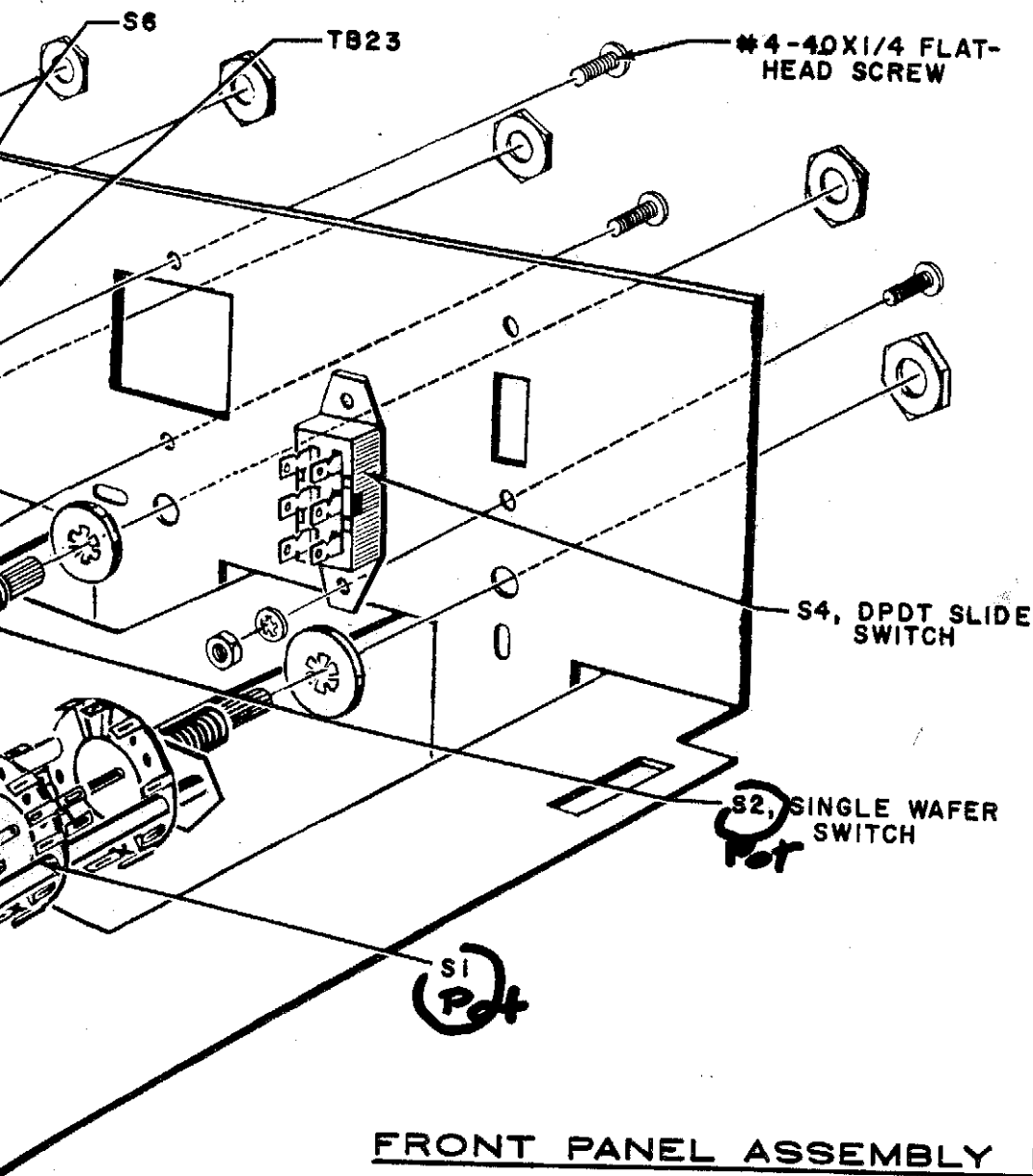

FRONT PANEL ASSEMBLY FIG. 6

Next to the rotating shaft, on the front plate each potentiometer and rotary switch, you will find a small locating lug. Next to the round $3/8$ " mounting hole for each potentiometer and rotary switch (in the front chassis panel) you will find a small, elliptically-shaped hole. The rotating shaft bushing on the control fits through the round hole while the locating lug fits through the adjacent elliptical hole when the control is oriented in the proper direction on the panel.

Mount dual 750K potentiometer R31, 32; dual 500K potentiometer R33, 34; concentric 1M potentiometer R45, 46; and concentric 500K potentiometer with switch R47, 48, S3, in the proper loca-

tions on the front chassis panel, as shown in the drawing. Orient each control so that the locating lug fits into its appropriate and adjacent elliptical hole. Between each control and the panel, place a $3/8$ " lockwasher. Secure each control to the panel using a $3/8$ " hex nut.

5. Following the above procedure, mount the single wafer rotary switch S2 at the appropriate location on the front chassis panel. Orient the switch so that the locating lug fits into the adjacent elliptical hole. Between the switch and the panel, place a $3/8$ " lockwasher. Secure the switch to the panel using a $3/8$ " hex nut.

The following steps refer to figure 7.

- (✓) 1. Run the twisted leads along the chassis, as shown. Dress the leads along the chassis using two small metal cable clamps. Secure the two cable clamps to the chassis using two #6-32 x 5/16 screws, two #6 lockwashers and two #6-32 hex nuts. Note that one cable clamp is located in a hole near the power transformer mounting and a second cable clamp is located in a hole near the electrolytic can capacitor, C35. See figure 2. Do not tighten the nuts holding the twisted leads yet because other cable clamps will be mounted on the underside of the chassis using the same screws. Do not use the two larger cable clamps.
- (✓) 2. From the twisted leads, connect the red wire to S8-1 (S1), the grey wire to S8-2 (S1), the white wire to S8-5 (S1), the green wire to S8-3 (S1) and the blue wire to S8-6 (S1). Dress the leads along the front panel away from potentiometers R47, R48, S3.
- (✓) 3. Connect one end of a 10" piece of yellow wire to X11-2 (S1) and one end of an 11 1/2" piece of brown wire to X11-1 (S1). Twist the leads together and run them along the front panel, as shown. Dress these leads away from potentiometers R47, R48, S3. Push the other end of the twisted pair through rectangular hole "K" to the bottom side of the chassis.

NOTE: Two printed circuit plates are soldered to the dual potentiometers. One printed circuit plate, PC1, gets connected to the potentiometers R45 and R47, nearest the front apron. The other printed circuit plate, PC2, gets connected to the potentiometers R46 and R48 mounted on the rear of the front potentiometers. To keep the drawings clear and simple, the first plate, PC1, is mounted and wired in first, with the associated connections. The rear potentiometer is shown dotted in.

In Figure 8, the second plate, PC2 is mounted and wired into the circuit, with its associated connections. In this drawing, the front potentiometer, R45, is shown dotted in. All the connections made previously for PC1 are not shown in this drawing to avoid confusion.

Th

chr
ac
tai
an
vie
swi

S

S

F
(✓) 4.
(C)
(✓) 5.
(C)
(✓) 6.

co
P
sh
le
th
th
le

to
(✓) 7.
w
o
th
si
(✓) 8.
(C)
(✓) 9.
(C)
(✓) 1
S
(✓) 1
(C)
(✓) 1
to
w
th
th
(✓) 1
(C)
(✓) 1
(C)

FRONT PANEL WIRING

4. Connect a 6" piece of yellow wire from R47-3 (C) to S7-12 (C).
5. Connect a 6" piece of blue wire from R47-1 (C) to S7-9 (C).
6. On printed circuit PC1, cut leads #2, #3 and #6 to 1/2"; cut leads #1, #4, #5 and #7 to 2" and cover each of these with 1 3/4" pieces of spaghetti. Place the plate against the panel in the direction shown, so that lead #2 is next to lug R45-1 and lead #6 is next to lug R45-3. Dress the leads so that they are all pointing towards you, away from the front panel. Connect lead #6 to R45-3 (S1), lead #3 to R45-2 (S1), lead #2 to R45-1 (S1), lead #7 to R47-1 (S2), lead #4 to R47-2 (S1), lead #1 to R47-3 (S2) and lead #5 to TB21-1 (C).
7. Connect one end of a 4 1/2" piece of white wire to TB21-1 (S2) and one end of a 6 1/2" piece of yellow wire to TB21-2 (C). Push both leads through the rectangular hole "J" to the bottom side of the chassis.
8. Connect a 3/4" piece of bare wire from S7-1 (C) to S7-4 (C).
9. Connect a 3/4" piece of bare wire from S7-7 (C) to S7-10 (C).
10. Connect a 3 1/2" piece of black wire from S7-10 (C) to TB23-2 (C).
11. Connect a 5" piece of black wire from S7-4 (C) to TB23-1 (C).
12. Connect one end of a 6" piece of grey wire to S7-3 (C) and one end of a 7" piece of blue wire to S7-9 (C). Run both leads along the panel, through rectangular hole "I" to the bottom side of the chassis.
13. Connect a 5" piece of blue wire from S7-9 (S3) to S6-10 (C).
14. Connect a 5" piece of grey wire from S7-3 (C) to S6-7 (C).
15. Connect a 7" piece of green wire from S5-12 (C) to R33-7 (S1).
16. Connect a 6 1/2" piece of green wire from S5-2 (C) to R34-8 (S1).
17. Connect one end of a 4" piece of orange wire to TB23-1 (C) and one end of a 3 1/2" piece of white wire to TB23-2 (C). Run both leads along the front panel as shown and push them through rectangular hole "I" to the bottom side of the chassis.
18. Connect one end of a 5" piece of green wire to S6-2 (C), one end of a 6" piece of white wire to S6-5 (C), one end of a 7" piece of blue wire to S6-8 (C) and one end of a 9" piece of yellow wire to S6-11 (C). Push the other end of all leads through hole "H" to the bottom side of the chassis.
19. Connect one end of a 3" piece of white wire to TB22-1 (C) and one end of a 4" piece of brown wire to TB22-2 (C). Push the other end of both leads through hole "H" to the bottom side of the chassis.
20. Connect a 3/4" piece of bare wire from S5-2 (S2) to S5-6 (S1).
21. Connect a 3/4" piece of bare wire from S5-8 (S1) to S5-12 (S2).
22. Connect a 2" piece of black wire from S2B-10 (C) to S2B-4 (C).
23. Connect a 3" piece of grey wire from S4-4 (S1) to S2B-10 (S2).
24. Connect a 3 1/2" piece of white wire from S4-1 (S1) to S2B-7 (C).
25. Connect a 4" piece of grey wire from S1D-3 (S1) to S2B-2 (C).
26. Connect one end of a 7" piece of grey wire to S4-5 (S1) and one end of a 6" piece of red wire to S4-2 (S1). Run both leads along the front panel as shown. Push them through hole "H" to the bottom of the chassis.

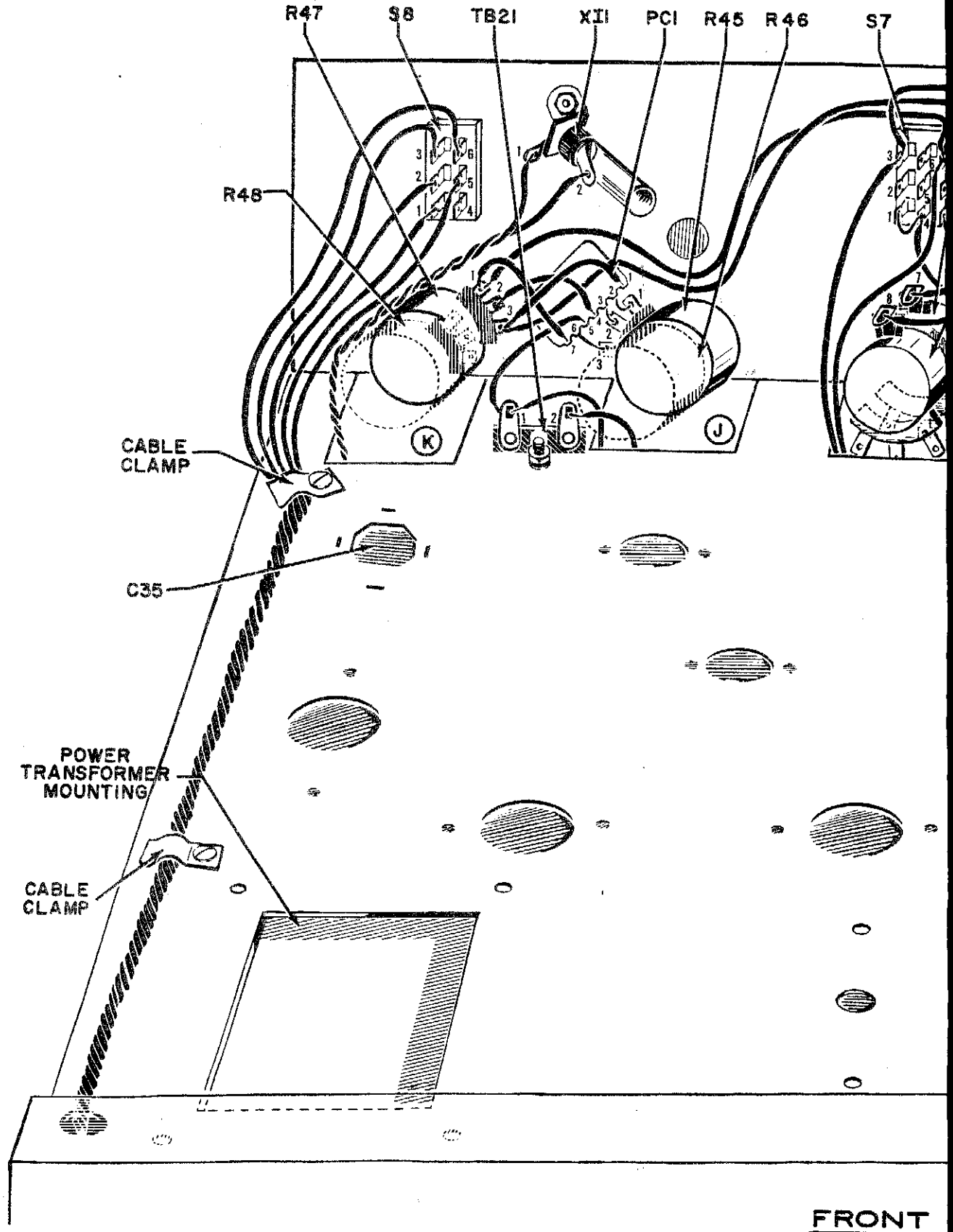

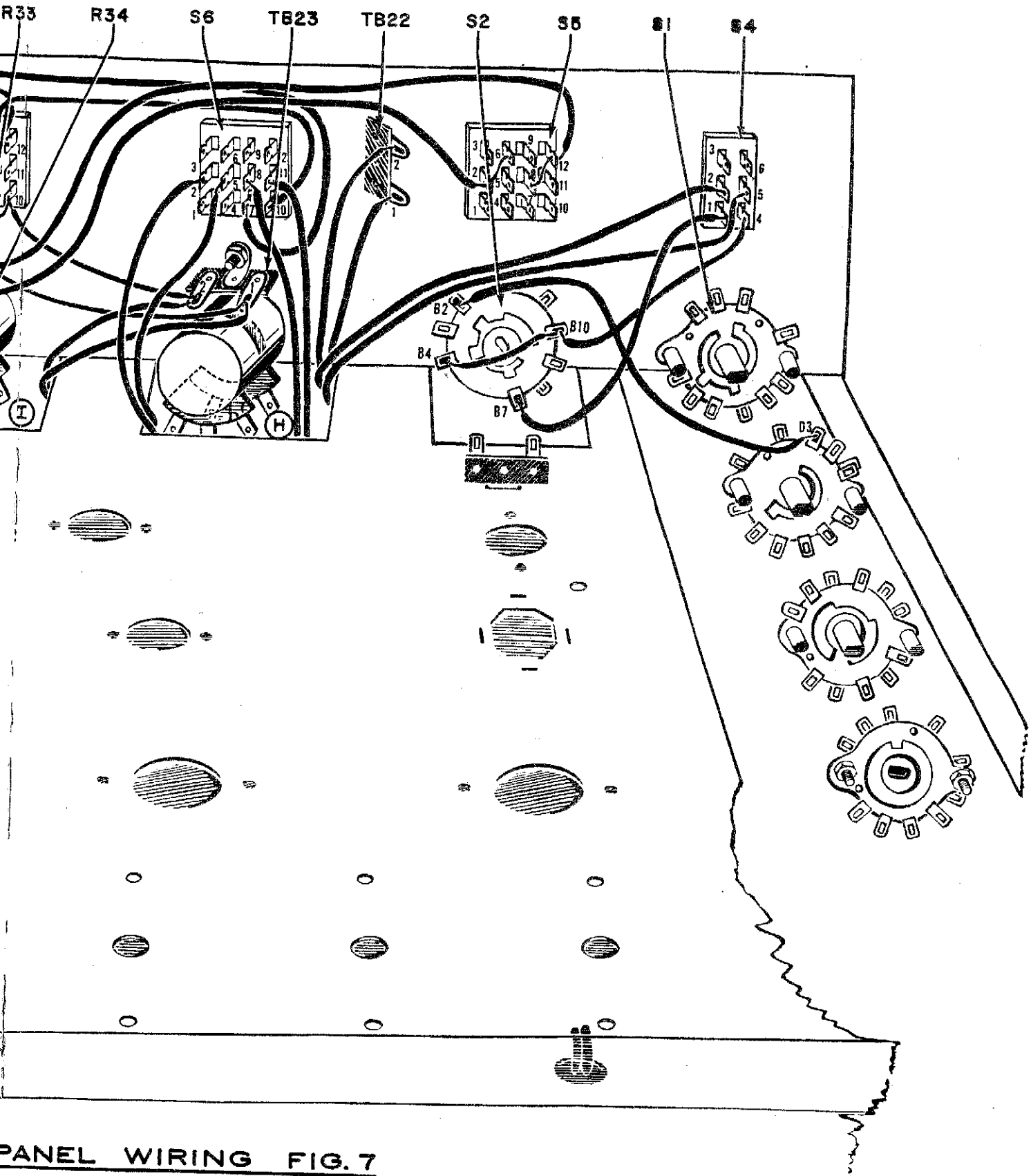

PANEL WIRING FIG. 7

The following steps refer to figure 8.

- (✓) 1. Connect one end of a 12" piece of black wire to S3-7 (S1) and one end of a 15" piece of black wire to S3-8 (S1). Twist the leads together and push them through the rectangular hole "K" to the bottom side of the chassis.
- (✓) 2. Cut all leads on two .0068mfd (6.8K or 6,800mmf) disc capacitors, C27 and C28, to 1/2". Connect C27 from S7-8 (S1) to S7-7 (S2). Connect C28 from S7-2 (S1) to S7-1 (S2).
- (✓) 3. Cut all leads on two .0015mfd (1.5K or 1500mmf) disc capacitors, C25 and C26, to 1/2". Connect C25 from S7-11 (S1) to S7-10 (S3). Connect C26 from S7-5 (S1) to S7-4 (S3).
- (✓) 4. Connect a 6" piece of white wire from R48-6 (C) to S7-6 (C).
- (✓) 5. Connect a 6" piece of grey wire from R48-4 (C) to S7-3 (S3).
- (✓) 6. On printed circuit plate PC2, cut leads #2, #3 and #6 to 1/2"; cut leads #1, #4 and #7 to 1 3/4" and cover each of these with a 1 1/2" piece of spaghetti. Cut lead #5 to 1". Place the plate against R46 as shown. Connect lead #2 to R46-4 (S1), lead #3 to R46-5 (S1), lead #6 to R46-6 (S1), lead #1 to R48-6 (S2), lead #4 to R48-5 (S1), lead #7 to R48-4 (S2) and lead #5 to TB21-2 (S2).
- (✓) 7. Connect a 4" piece of white wire from S7-6 (S2) to S6-1 (C).
- (✓) 8. Connect a 4" piece of grey wire from S7-12 (S2) to S6-4 (C).
- (✓) 9. Cut all leads on two .015mfd (15K or 15,000 mmf) disc capacitors, C23 and C24, to 1/2". Connect C23 from S6-5 (S2) to S6-4 (S2). Connect C24 from S6-2 (S2) to S6-1 (S2).
- (✓) 10. Cut all leads on two .009mfd (9K or 9000mmf) disc capacitor, C29 and C30, to 1/2". Connect C29 from S6-11 (S2) to S6-10 (S2). Connect C30 from S6-8 (S2) to S6-7 (S2).

FRONT PANEL WIRING (CONTINUED)

- (✓) 11. Cut all leads on two 68mmf disc capacitors, C11 and C12, to 3/4". Connect C12 from TB22-1 (S2) to S5-3 (S1). Cover one end of C11 with a 1/2" piece of spaghetti and connect to S5-9 (S1). Connect the other end of C11 to TB22-2 (S2).
- (✓) 12. Connect a 3 1/2" piece of yellow wire from S1E-4 (S1) to S2A-8 (C).
- (✓) 13. Cut all leads on two 6.8K (blue, grey, red, silver) resistors, R29 and R30, to 1/2". Connect R29 from S2B-2 (S2) to S2B-3 (S1). Connect R30 from S2A-8 (S2) to S2B-9 (S1).
- (✓) 14. From S1D-8 connect the blue lead to S4-6 (S1).
- (✓) 15. From S1E-9, connect the brown lead to S4-3 (S1).
- (✓) 16. Run the black and the grey shielded cables from hole "AA" along the chassis, as shown. Secure it to the chassis using two small metal cable clamps. Mount one cable clamp to the chassis using the hole between XV1 and C36. Use one of the transformer T2 mounting holes to mount the second cable clamp. Use one #6-32 x 5/16 screw, one #6 lockwasher and one #6-32 hex nut to secure the first clamp to the chassis. Use one #8-32 x 3/8" screw, one #8 lockwasher and one #8-32 hex nut to secure the second clamp to the chassis. Do not tighten the latter screw too much as it is to be removed subsequently when the transformer will be mounted.
- (✓) 17. Connect the center conductor from the black shielded cable to S2B-4 (S2).
- (✓) 18. Connect a 3" piece of black wire from S1F-6 (C) to S2A-11 (C).
- (✓) 19. Connect the twisted strands from the grey shielded cable to S2A-1 (S2) and the center conductor to S2B-7 (S2).
- (✓) 20. Cut all leads on two 2.7K (red, violet, red, silver) resistors, R35 and R36, to 1/2". Connect R35 from S5-10 (C) to S5-11 (S1). Connect R36 from S5-4 (C) to S5-5 (S1).
- (✓) 21. Connect a 5" piece of black wire from TB23-1 (S3) to TB20-1 (C).

- (✓) 22. Connect a 5" piece of black wire from TB23-2 (S3) to TB20-2 (C).
- (✓) 23. Cut all leads on two .2mfd disc capacitors, C13 and C14, to 1". Connect C13 from S5-10 (S2) to TB20-1 (S2). Connect C14 from S5-4 (S2) to TB20-2 (S2).
- (✓) 24. Connect a 1" piece of bare wire from S1F-6 (S3) to S1C-6 (S4).
- (✓) 25. Connect a 3/4" piece of bare wire from S1E-1 (S1) to S1E-2 (C).
- (✓) 26. Connect a 1 1/2" piece of blue wire from S1G-1 (S1) to S1G-4 (C).
- (✓) 27. Cut all leads on two 120K (brown, red, yellow, silver) resistors, R23 and R24, to 1/2". Connect R23 from S1D-2 (S1) to S1C-4 (C). Connect R24 from S1F-3 (S1) to S1F-5 (C).
- (✓) 28. Cut all leads on two 330mmf disc capacitors, C5 and C6, to 3/4". Connect C5 from S1B-4 (S1) to S1C-4 (S2). Connect C6 from S1F-5 (S2) to S1G-5 (S1).
- (✓) 29. Cut all leads on two 200K (red, black, yellow, gold) resistors, R5 and R6, to 1/2". Connect R5 from S1B-1 (C) to S1B-3 (C). Connect R6 from S1G-2 (C) to S1G-4 (C).
- (✓) 30. Cut all leads on two 400mmf disc capacitors, C1 and C2, to 1/2". Connect C1 from S1B-1 (C) to S1B-3 (S3). Connect C2 from S1G-2 (C) to S1G-4 (S3).
- (✓) 31. Cut all leads on two 4M Ω (yellow, black, green, gold) resistors, R9 and R10, to 3/4". Connect R9 from S1B-1 (C) to S1D-1 (C). Connect R10 from S1E-2 (C) to S1G-2 (C).
- (✓) 32. Cut all leads on a .0012mfd (1.2K or 1200 mmf) disc capacitors, C3 and C4, to 3/4". Connect C3 from S1B-1 (S4) to S1D-1 (S3). Connect C4 from S1E-2 (S3) to S1G-2 (S4).

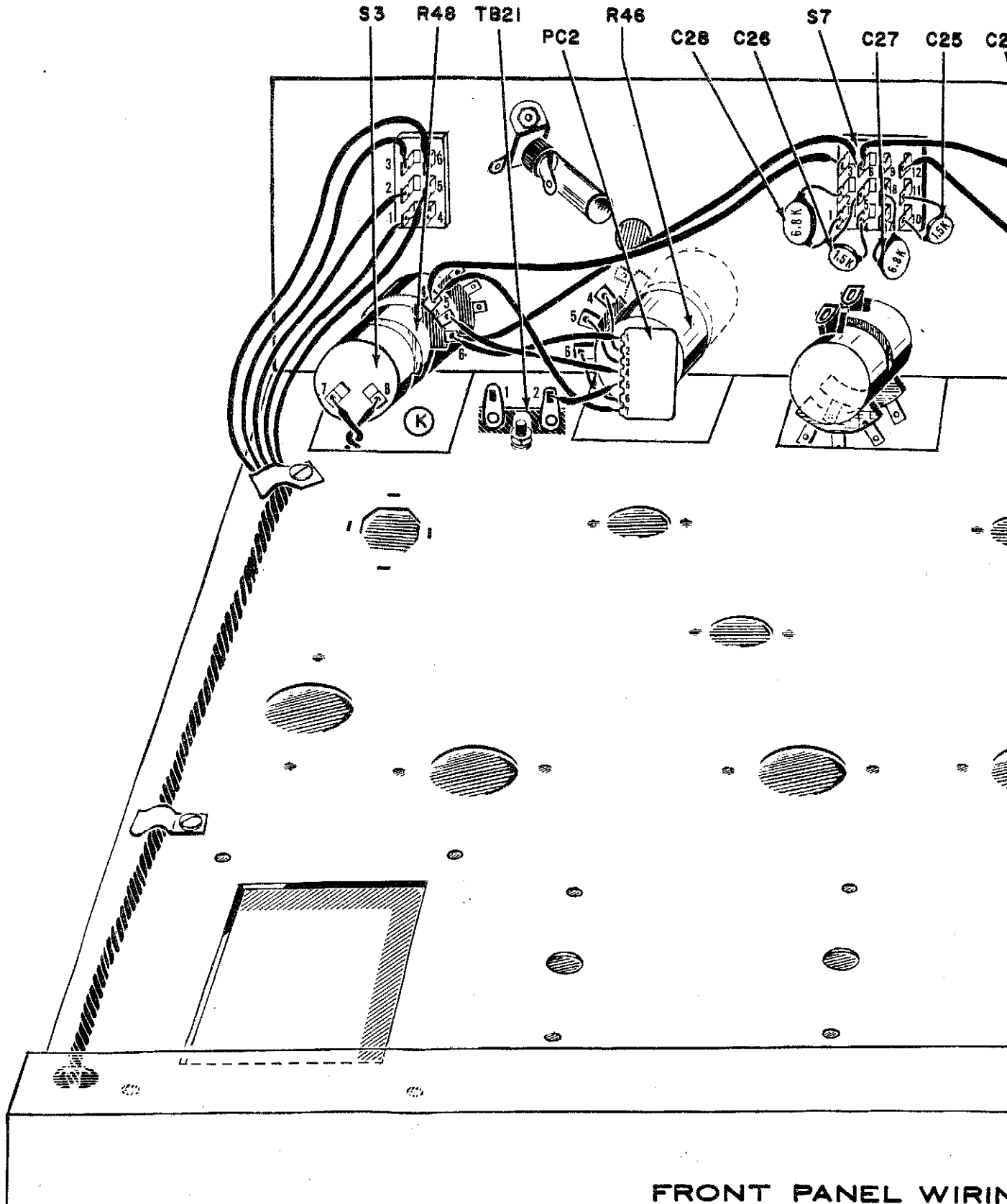

FRONT PANEL WIRING

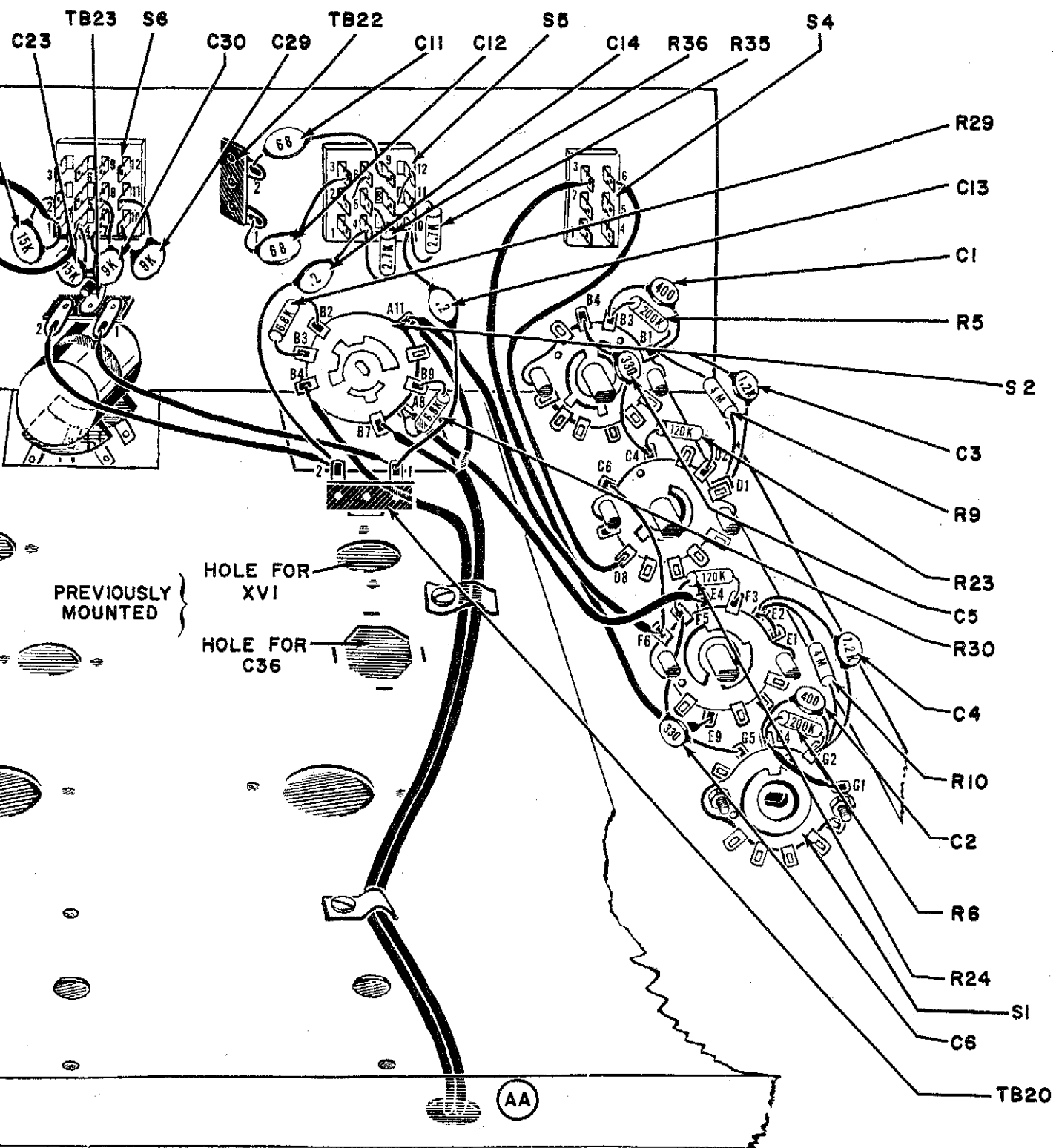

wn
 ter
 ct
 C)
).
 w
 ce
 ds
 1-
 4
 .9
 4
 re
 m
 id
 ie
 ie
 w
 e
 ls
 1-
 2
 7
 it
 -
 e
 d
 1,
 2
 7
 .
 A

(CONTINUED) FIG. 8

BOTTOM WIRING

The following steps refer to figure 9.

In the drawing, the back panel is shown laying next to the rear side of the main chassis. Actually, the panel has already been attached to the main chassis. It is drawn in this fashion to clarify the ensuing wiring steps.

- (✓) 1. From hole "A", connect the green lead to TB13-2 (C).
- (✓) 2. From rectangular cutout "K" at the front of the chassis, run the two black leads along the bottom surface near the side as shown. Connect the shorter lead to J16-2 (C) and the longer lead to J17-2 (C). Two small metal clamps are used to hold the wires to the bottom surface of the chassis. These metal clamps are secured to the chassis using the same screws which were previously used to secure the clamps holding the five twisted wires to the chassis. To do this, first remove the nut and lockwasher from the screw holding one clamp. Next place the clamp as shown over the protruding screw threads on the bottom surface of the chassis. Secure the screw and two clamps (the one on the top surface and the one on the bottom surface) to the chassis using the lockwasher and nut just removed. Repeat this for the second ground clamp.
- (✓) 3. From rectangular cutout "K", connect the brown lead to XV3-9 (C) and the yellow lead to XV3-4 (C).
- (✓) 4. From rectangular cutout "J", connect the white lead to XV3-7 (C) and the yellow lead to XV4-7 (C).
- (✓) 5. From rectangular cutout "I", connect the orange lead to R33-3 (C), the white lead to R34-6 (C), the blue lead to TB24-2 (C) and the grey lead to TB24-1 (C).

From rectangular cutout "H" connect the green lead to TB15-2 (C), the grey lead to R31-3 (S1),

the short white lead to R32-5 (C), the longer white lead to TB15-3 (C), the blue lead to XV6-7 (C), the yellow lead to XV5-7 (C), the brown lead to R31-2 (C) and the red lead to R32-4 (S1).

- (✓) 7. From the large rectangular cutout "F" and switch S1, connect the black lead from S1C-6 to TB7-2 (C), the green lead from S1D-7 to TB19-4 (C), the orange lead from S1F-8 to TB14-3 (C), the black lead from S1H-11 to TB14-2 (C), the center conductor from the grey shielded lead connected to S1B-5 and S1A-10 to TB7-1 (C) and the shield leads to TB7-2 (C), the center conductor from the black shielded lead connected to S1B-11 and S1A-10 to XV1-8 (C), the center conductor from the black shielded lead connected to S1G-12 and S1H-11 to XV2-8 (C), and the center conductor from the grey shielded lead connected to S1G-6 to TB14-1 (C) and the shield strands to TB14-2 (C).
- (✓) 8. Connect a 3" piece of green wire from R34-5 (S1) to XV4-2 (S1).
- (✓) 9. Connect a 4" piece of green wire from R33-2 (S1) to XV3-2 (S1).
- (✓) 10. Connect a 2 1/4" piece of black wire from R34-6 (S2) to TB15-1 (C).
- (✓) 11. Connect a 5" piece of black wire from R33-3 (S2) to TB12-1 (C).
- (✓) 12. Connect a 3 1/2" piece of grey wire from R31-2 (S2) to R33-1 (S1).
- (✓) 13. Connect a 3 1/2" piece of white wire from R32-5 (S2) to R34-4 (S1).
- (✓) 14. Connect one end of a 10" piece of yellow wire to XV3-5 (C) and one end of an 11" piece of brown wire to XV3-9 (C). Twist the leads together and run them along the chassis as shown. Connect the other end of the brown wire to XV1-9 (S1) and the yellow wire to XV1-5 (C).

- (✓) 15. Connect a 1/2" piece of bare wire from XV1-4 (S1) to XV1-5 (S2).
- (✓) 16. Connect a 1/2" piece of bare wire from XV3-4 (S2) to XV3-5 (C).
- (✓) 17. Connect one end of a 5" piece of yellow wire to XV3-5 (S3) and one end of a 3" piece of brown wire to XV3-9 (S3). Twist the leads together and run them along the chassis as shown. Connect the other end of the yellow wire to XV5-4 (C) and one end of the brown wire to XV5-9 (C).
- (✓) 18. Connect a 1/2" piece of bare wire from XV5-4 (C) to XV5-5 (S1).
- (✓) 19. Connect one end of a 5" piece of yellow wire to XV5-4 (S3) and one end of a 5" piece of brown wire to XV5-9 (S2). Twist the two leads together and run them along the chassis, as shown. Connect the other end of the yellow wire to XV9-2 (C) and the other end of the brown wire to XV9-7 (C).
- (✓) 20. Connect one end of a 2" piece of yellow wire to XV9-2 (S2) and one end of a 3" piece of brown wire to XV9-7 (S2). Twist the leads together and run them along the chassis, as shown. Connect the other end of the yellow wire to R77-1 (C) and the other end of the brown wire to R77-2 (C).
- () 21. Connect one end of a 2 1/2" piece of yellow wire to R77-1 (S2) and one end of a 3 1/2" piece of brown wire to R77-2 (S2). Twist the two leads together and run them along the chassis, as shown. Connect the other end of the yellow wire to XV7-2 (C) and the other end of the brown wire to XV7-7 (C). Be careful that the solder lugs on R77 should not short to its mounting screws.
- (✓) 22. Connect a 1/2" piece of bare wire from XV4-4 (S1) to XV4-5 (C).
- (✓) 23. Connect one end of a 6" piece of yellow wire to XV4-5 (S2) and one end of a 4" piece of brown wire to XV4-9 (S1). Twist the two leads together and run them along the chassis, as shown. Connect the other end of the yellow wire to XV6-4 (C) and the other end of the brown wire to XV6-9 (C).
- (✓) 24. Connect a 1/2" piece of bare wire from XV6-4 (C) to XV6-5 (S1).
- (✓) 25. Connect one end of a 6" piece of yellow wire to XV6-4 (S3) and one end of a 5" piece of brown wire to XV6-9 (S2). Twist the two leads together and run them along the chassis as shown. Connect the other end of the yellow wire to XV10-2 (C) and the other end of the brown wire to XV10-7 (C).
- (✓) 26. Connect one end of a 4 1/2" piece of yellow wire to XV10-2 (C) and one end of a 4 1/2" piece of brown wire to XV10-7 (C). Twist the two leads together and run them along the chassis, as shown. Connect the other end of the yellow wire to XV2-4 (C) and the other end of the brown wire to XV2-9 (S1).
- (✓) 27. Connect a 1/2" piece of bare wire from XV2-4 (S2) to XV2-5 (S1).
- (✓) 28. Connect one end of a 2" piece of yellow wire to XV10-2 (S3) and one end of a 3" piece of brown wire to XV10-7 (S3). Twist the leads together and run them along the chassis, as shown. Connect the other end of the yellow wire to R78-1 (C) and the other end of the brown wire to R78-2 (C).
- (✓) 29. Connect one end of a 2 1/2" piece of yellow wire to R78-1 (S2) and one end of a 3 1/2" piece of brown wire to R78-2 (S2). Twist the two leads together and run them along the chassis, as shown. Connect the other end of the yellow wire to XV8-2 (C) and the other end of the brown wire to XV8-7 (C). Be careful that the solder lugs on R78 do not short to its mounting screws.
- (✓) 30. Cut both leads on the 30mfd, 400 volts electrolytic capacitor, C37, to 1 1/4". Connect the positive lead to TB12-2 (C) and the negative lead to ground lug "M" (S1) at C35.
- (✓) 31. Cut both leads on an 8.2K (grey, red, red, silver) resistor, R41, to 3/4". Connect from TB12-2 (C) to C35-B (C).
- (✓) 32. Cut both leads on the 1800Ω 5 watt resistor, R42, to 1". Connect from C35-B (C) to XV11-8 (C).
- (✓) 33. Connect a 2 3/4" piece of red wire from C35-A (S1) to XV11-8 (C).
- (✓) 34. Connect a 5 1/2" piece of red wire from C35-B (S3) to XV7-8 (C).
- (✓) 35. Connect a 4 1/2" piece of red wire from TB12-2 (S3) to TB11-2 (C).

EICO ST40

- (✓) 36. Connect a 13" piece of red wire from XV11-8 (C) to TB13-1 (C). Run the lead along the chassis, as shown.
- (✓) 37. Connect a 5" piece of red wire from TB10-2 (C) to TB8-2 (C).
- (✓) 38. Connect a 5 1/2" piece of red wire from TB8-2 (C) to C36-B (C).
- (✓) 39. Connect a 5" piece of red wire from TB19-3 (C) to C36-A (C).
- (✓) 40. Connect a 7 1/2" piece of red wire from C36-C (C) to TB6-2 (C).
- (✓) 41. Connect a 4 1/2" piece of red wire from TB11-2 (C) to TB9-2 (C).
- (✓) 42. Connect a 4" piece of red wire from XV7-8 (C) to XV9-8 (C).
- (✓) 43. Connect a 4" piece of red wire from XV9-8 (C) to XV8-8 (C).
- (✓) 44. Connect a 4" piece of red wire from XV8-8 (C) to XV10-8 (C).
- (✓) 45. Connect a 4 1/2" piece of black wire from TB7-2 (C) to TB19-2 (C).
- (✓) 46. Connect a 5 1/2" piece of black wire from TB19-2 (C) to TB14-2 (C).
- (✓) 47. Connect a 4 1/2" piece of black wire from TB19-1 (C) to XV1-8 (C).
- (✓) 48. Connect a 4" piece of black wire from TB8-1 (C) to TB15-1 (C).
- (✓) 49. Connect a 7" piece of black wire from TB19-2 (C) to TB10-1 (C).
- (✓) 50. Connect a 4" piece of black wire from TB12-1 (C) to TB10-1 (C).
- (✓) 51. Connect a 4" piece of black wire from TB10-1 (C) to TB17 (C).
- (✓) 52. Connect a 3 1/2" piece of black wire from TB8-1 (C) to TB16 (C).
- (✓) 53. Connect a 4" piece of black wire from TB17 (C) to TB11-1 (C).
- (✓) 54. Connect a 4" piece of black wire from TB16 (C) to TB9-1 (C).
- (✓) 55. Connect a 3 1/2" piece of black wire from TB14-2 (C) to TB18 (C).
- (✓) 56. Connect a 4 1/2" piece of black wire from TB6-1 (C) to XV2-8 (C).
- (✓) 57. Connect a 4" piece of yellow wire from XV7-5 (C) to XV9-5 (C).
- (✓) 58. Connect a 4" piece of yellow wire from XV8-5 (C) to XV10-5 (C).
- (✓) 59. Connect a 10" piece of green wire from TB5-2 (S4) to XV5-8 (C).
- (✓) 60. Connect an 11" piece of green wire from TB4-2 (S3) to XV6-8 (C).
- (✓) 61. Cut all leads on two 1.5K (brown, green, red, silver) resistors, R43 and R44, to 1/2". Connect R43 from XV3-3 (C) to TB12-1 (C). Connect R44 from XV4-3 (C) to TB15-1 (C).
- (✓) 62. Cut all leads on two .009mfd (9K or 9000mmf) disc capacitors, C41 and C42, to 1/2". Connect C42 from XV4-3 (S2) to TB15-1 (S4). Connect C41 from XV3-3 (S2) to TB12-1 (S4).
- (✓) 63. Cut all leads on two 1K (brown, black, red, silver) resistors, R51 and R52, to 1/2". Connect R51 from XV3-8 (C) to TB10-1 (C). Connect R52 from XV4-8 (C) to TB8-1 (C).
- (✓) 64. Cut all leads on two .015mfd (15K or 15,000 mmf) disc capacitors, C31 and C32, to 3/4". Connect C31 from XV3-8 (S2) to TB10-1 (C). Connect C32 from XV4-8 (S2) to TB8-1 (C).
- (✓) 65. Cut all leads on two 470K (yellow, violet, yellow, silver) resistors, R49 and R50, to 3/4". Connect R49 from XV3-7 (S2) to TB10-1 (S6). Connect R50 from XV4-7 (S2) to TB8-1 (C).
- (✓) 66. Connect a 1 1/2" piece of bare wire from TB8-1 (S6) to TB19-2 (C).

BOTTOM WIRING (CONTINUED)

The following steps refer to figure 10.

1. Cut all leads on two 33K (orange, orange, orange, gold) 1/2 watt resistors, R37 and R38, to 1/2". Connect R37 from XV3-1 (C) to TB10-2 (C). Connect R38 from XV4-1 (C) to TB8-2 (C).
2. On one end of two 33K (orange, orange, orange, gold) 1/2 watt resistors, R39 and R40, cut the leads to 1/2". Connect the 1/2" end of R39 to TB10-2 (S3) and the 1/2" end of R40 to TB8-2 (S4). Cut the remaining ends of both resistors to 1 1/4" and cover each lead with a 1" piece of spaghetti. Connect this end of R39 to XV3-6 (C) and this end of R40 to XV4-6 (C).
3. Cut all leads on four .1mfd (brown, black, yellow, white, yellow) molded capacitors, C15, C16, C17 and C18 to 7/8". Cover each lead with a 5/8" piece of spaghetti. Connect C15 from TB15-3 (S2) to XV3-1 (S2). Connect C16 from TB15-2 (S2) to XV4-1 (S2). Connect C17 from TB24-2 (S2) to XV3-6 (S2). Connect C18 from TB24-1 (S2) to XV4-6 (S2).
4. Cut both leads on a 15K (brown, green, orange, silver) resistor, R26, to 1/2". Connect from C36-A (C) to C36-B (S2).
5. Cut both leads on a 120K (brown, red, yellow, silver) resistor, R25, to 1/2". Connect from C36-A (C) to C36-C (C).
6. Cut both leads on a 200K (red, black, yellow, gold) resistor, R7, to 1". Cover each lead with a 3/4" piece of spaghetti. Connect from XV1-6 (C) to C36-C (S3).
7. Cut both leads on a 200K (red, black, yellow, gold) resistor, R8, to 1/2". Connect from XV2-6 (C) to TB6-2 (S2).
8. Cut all leads on two 68K (blue, grey, orange, gold) resistor, R27 and R28, to 1/2". Connect R27 from XV1-3 (C) to TB19-1 (S2). Connect R28 from XV2-3 (C) to TB6-1 (S2).
9. Cut all leads on two 1.2K (brown, red, red, gold) resistors, R21 and R22, to 1/2". Connect R21 from XV1-3 (S2) to TB19-2 (C). Connect R22 from XV2-3 (S2) to TB18 (C).
10. Cut all leads on two 1.5M (brown, green, green, silver) resistors, R17 and R18, to 1/2". Connect R17 from XV1-2 (C) to TB19-2 (S6). Connect R18 from XV2-2 (C) to TB18 (S3).
11. Cut both leads on a 40K (yellow, black, orange, gold) resistor, R19, to 1/2". Connect from XV1-1 (C) to TB19-3 (S2).
12. Cut both leads on a 40K (yellow, black, orange, gold) resistor, R20, to 1". Cover each lead with a 3/4" piece of spaghetti. Connect from XV2-1 (C) to C36-A (C).
13. Cut both leads on the 33K, 5 watt resistor, R79, to 3/4". Cover each lead with a 1/2" piece of spaghetti. Connect from XV10-8 (C) to C36-A (S5).
14. Cut all leads on two 1M (brown, black, green, silver) resistors, R11 and R12, to 1/2". Connect R11 from TB7-1 (C) to TB7-2 (C). Connect R12 from TB14-1 (C) to TB14-2 (C).
15. Cut all leads on two 2.4K (red, yellow, red, gold) resistors, R15 and R16, to 5/8". Connect R15 from XV1-8 (S3) to TB7-2 (S5). Connect R16 from XV2-8 (S3) to TB14-2 (S6).
16. Cut both leads on the 22K (red, red, orange, silver) resistor, R13, to 1/2". Connect from XV1-7 (S1) to TB7-1 (S3).
17. Cut one lead on the 22K (red, red, orange, silver) resistor, R14, to 1/2" and connect it to XV2-7 (S1). Cut the other lead to 1" and connect it to TB14-1 (S3).
18. On four .025mfd (25K or 25,000mmf) disc capacitors, C7, C8, C9 and C10, cut all leads to 5/8". Connect C7 from XV1-2 (S2) to XV1-6 (S2). Connect C8 from XV2-2 (S2) to XV2-6 (S2). Connect C9 from TB19-4 (S2) to XV1-1 (S2). Connect

- C10 from TB14-3 (S2) to XV2-1 (S2). Bend all the capacitors down so that they are nearly parallel to the chassis. Note that none of the capacitor leads inadvertently short against other leads or solder pins.
- () 19. Connect a 1" piece of bare wire from XV5-2 (S1) to XV5-6 (C).
 - () 20. Connect a 1" piece of bare wire from XV6-2 (S1) to XV6-6 (C).
 - () 21. Cut all leads on four 82K (grey, red, orange, gold) resistors, R59, R60, R61 and R62, to 5/8". Connect R59 from XV5-1 (C) to TB11-2 (C). Connect R60 from XV6-1 (C) to TB9-2 (C). Connect R61 from XV5-3 (C) to TB17 (S3). Connect R62 from XV6-3 (C) to TB16 (S3).
 - () 22. Cut all leads on two 1138Ω resistors, R55 and R56, to 1/2". Connect R55 from TB11-1 (C) to XV5-8 (S2). Connect R56 from TB9-1 (C) to XV6-8 (S2).
 - () 23. Cut all leads on two 470K (yellow, violet, yellow, silver) resistors, R53 and R54, to 5/8". Connect R53 from XV5-7 (S2) to TB11-1 (S3). Connect R54 from XV6-7 (S2) to TB9-1 (S3).
 - () 24. Cut all leads on two 330K (orange, orange, yellow, silver) resistors, R63 and R64, to 1". Cover all leads with 3/4" pieces of spaghetti. Connect R63 from TB11-2 (S4) to XV5-6 (S2). Connect R64 from TB9-2 (S3) to XV6-6 (S2).
 - () 25. Connect a 2 1/2" piece of green wire from R77-3 (S1) to XV7-5 (C).
 - () 26. Connect a 2 1/2" piece of green wire from R78-3 (S1) to XV8-5 (C).
 - () 27. Connect a 1 1/4" piece of bare wire from XV7-8 (S3) to XV7-4 (S1).
 - () 28. Connect a 1 1/4" piece of bare wire from XV9-8 (S3) to XV9-4 (S1).
 - () 29. Connect a 1 1/4" piece of bare wire from XV8-8 (S3) to XV8-4 (S1).
 - () 30. Connect a 1 1/4" piece of bare wire from XV10-8 (S3) to XV10-4 (S1).
 - () 31. Cut all leads on four 10K (brown, black, orange, silver) resistors, R69, R70, R71 and R72 to 1/2". Connect R69 from XV7-1 (C) to XV7-6 (S1). Connect R71 from XV9-1 (C) to XV9-6 (S1). Connect R70 from XV8-1 (C) to XV8-6 (S1). Connect R72 from XV10-1 (C) to XV10-6 (S1).

The following steps refer to figure 2.

- () 32. On power transformer T3, cut both green leads to 5", both brown leads to 7", both yellow leads to 6", both red leads to 6", both black leads to 6", the white lead to 5" and the red-yellow lead to 4". Strip the insulation back 1/4" from the ends of each of the leads. Mount the power transformer through the rectangular cutout, so that the red and yellow leads are nearest the edge of the chassis. Secure the transformer to the chassis using four #8 lockwashers and four #8-32 hex nuts. Under each of three of the lockwashers, place a #8 ground lug, as shown.
- () 33. On the two output transformers, T1 and T2, cut the orange lead to 4 1/2", the green lead to 5", the black lead to 4", the yellow lead to 3 1/2", the blue lead to 5", the brown lead to 3 1/2" and the red lead to 3". Strip the insulation back 1/4" from the ends of each of the leads. Mount the two transformers noting the lead breakout in Figure 10.

On transformer T1, push the brown, blue and red leads through hole "D" and all the remaining leads through hole "E".

On transformer T2, push the brown, blue and red leads through hole "B" and all the remaining leads through hole "C".

To secure each transformer to the chassis, use four #8-32 x 3/8 screws, four #8 lockwashers and four #8-32 hex nuts. Under one lockwasher on each transformer, place a large metal cable clamp with the yellow, black, orange and green leads of the respective transformers being run under these clamps. See figure 10 for the orientation.

Under a second lockwasher on each transformer, place a #8 ground lug and position them as shown in figure 10. Note that the same screw holding the ground lug and transformer T2 to the

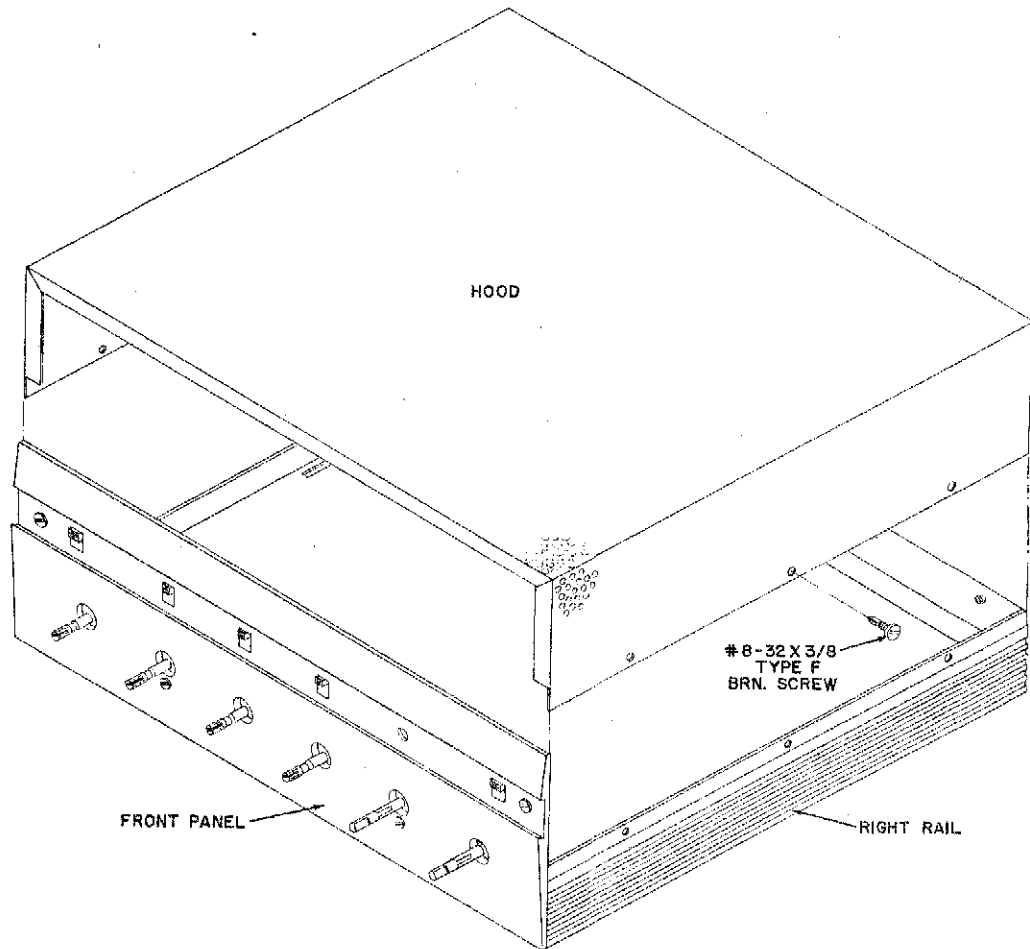

HOOD MOUNTING FIG. 13

wired amplifier, which may not be the case, re-check the wiring for errors or reversed connections and continuity.

- () 13. If the amplifier is to be mounted in a console, read carefully the "Mechanical Installation" section of the Instructions and follow the procedures outlined.
- () 14. Detailed information as to connection of phonographs, tuners, etc., to the amplifier inputs and speaker systems to the amplifier outputs, as well as a-c line connections and use of the hum adjustment control, is given in the "Electrical Installation" section.

SERVICE

If you are still having difficulty, write to our service department listing all possible indications that might be helpful. Note the code numbers printed in red under the word "Manual" on the front cover. If there is no code number, state this. If desired, you may return the amplifier to our factory where it will be placed in

operating condition for \$13.50 plus the cost of parts replaced due to their being damaged in the course of construction. This service policy applies only to completed amplifiers constructed in accordance with the instructions as stated in the manual. Amplifiers that are not completed or are modified will not be accepted for repair. Amplifiers that show evidence of acid core solder or paste fluxes will be returned not repaired. NOTE: Before returning this unit, be sure all parts are securely mounted. Attach a tag to the amplifier, giving your home address and the trouble with the unit. Pack very carefully in a rugged container, using sufficient packing material (cotton, shredded newspaper, or excelsior), to make the unit completely immovable within the container. The original shipping carton is satisfactory, providing the original inserts are used or sufficient packing material is inserted to keep the amplifier immovable. Ship by prepaid Railway Express, if possible, to the Service Dept., Electronic Instrument Co., Inc., 33-00 Northern Blvd., L.I.C. 1, New York. Return shipment will be made by express collect. Note that the carrier cannot be held liable for damages in transit if packing, IN HIS OPINION, is insufficient.

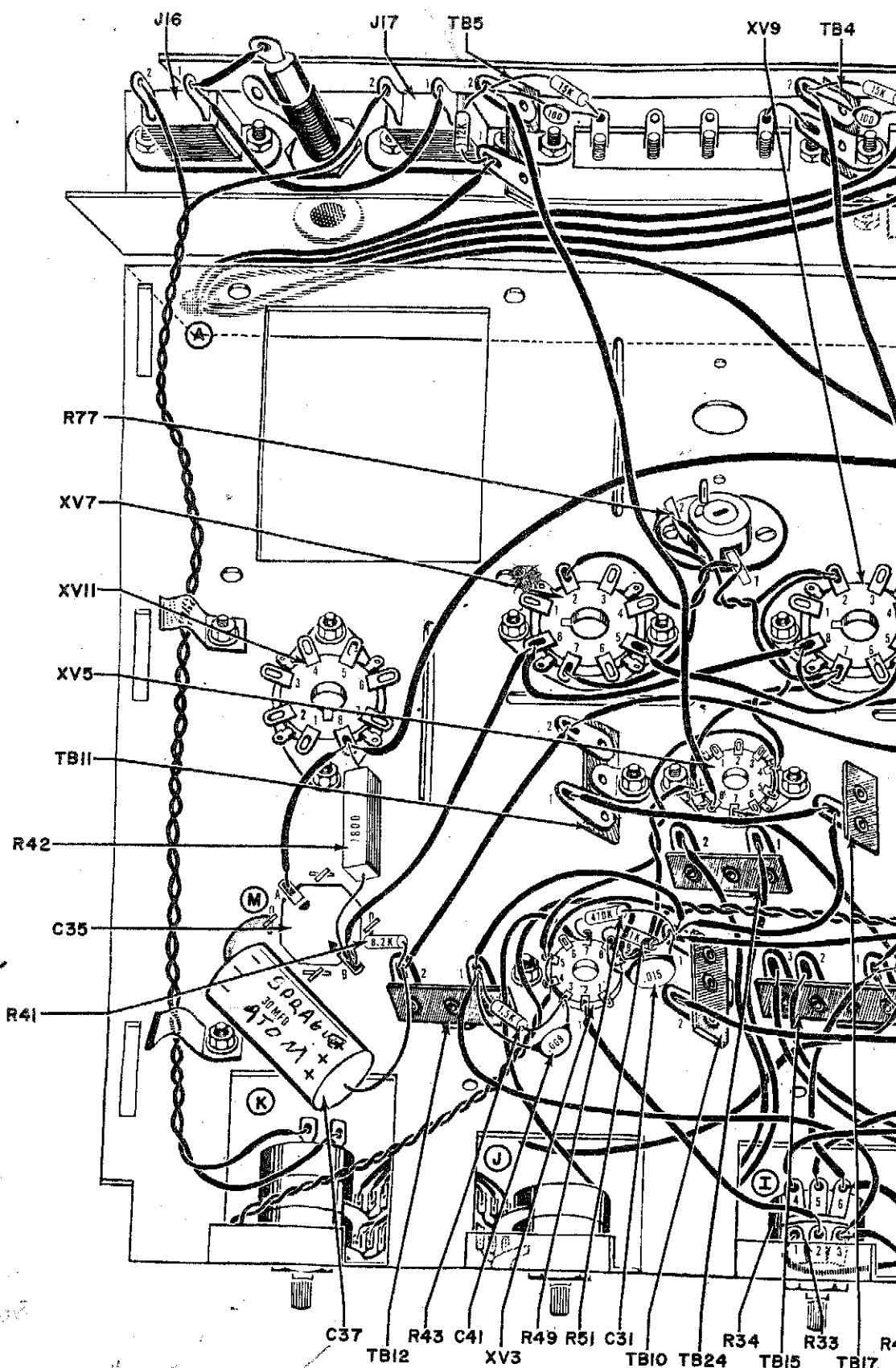

Position
 • C37 DIRECTLY
 TO GROUND BUSES
 • BLEEDING RESISTORS
 FROM C35 B TO
 GROUND BUSES
 (1 MEG 1/2 W)
 • C37 IS COUPLED
 ONE STAGE TO
 ANOTHER, E.G.
 C19 AN AND OF
 7247 IS LOWTAN
 GRID OF 15A1.
 SIGNAL CAPS
 MUST BE CRUISED
 IN AMP OF SIGNAL
 BUSES
 C35 & C36 ARE
 STORAGE CAPACITORS
 (C35 IS 1000 MFD 50VDC
 INSTALLED UNDER
 BATTERY)

Use
 47 mfd @ 450VDC
 ELECTROLYTIC
 (STANDARD)

BOTTOM W

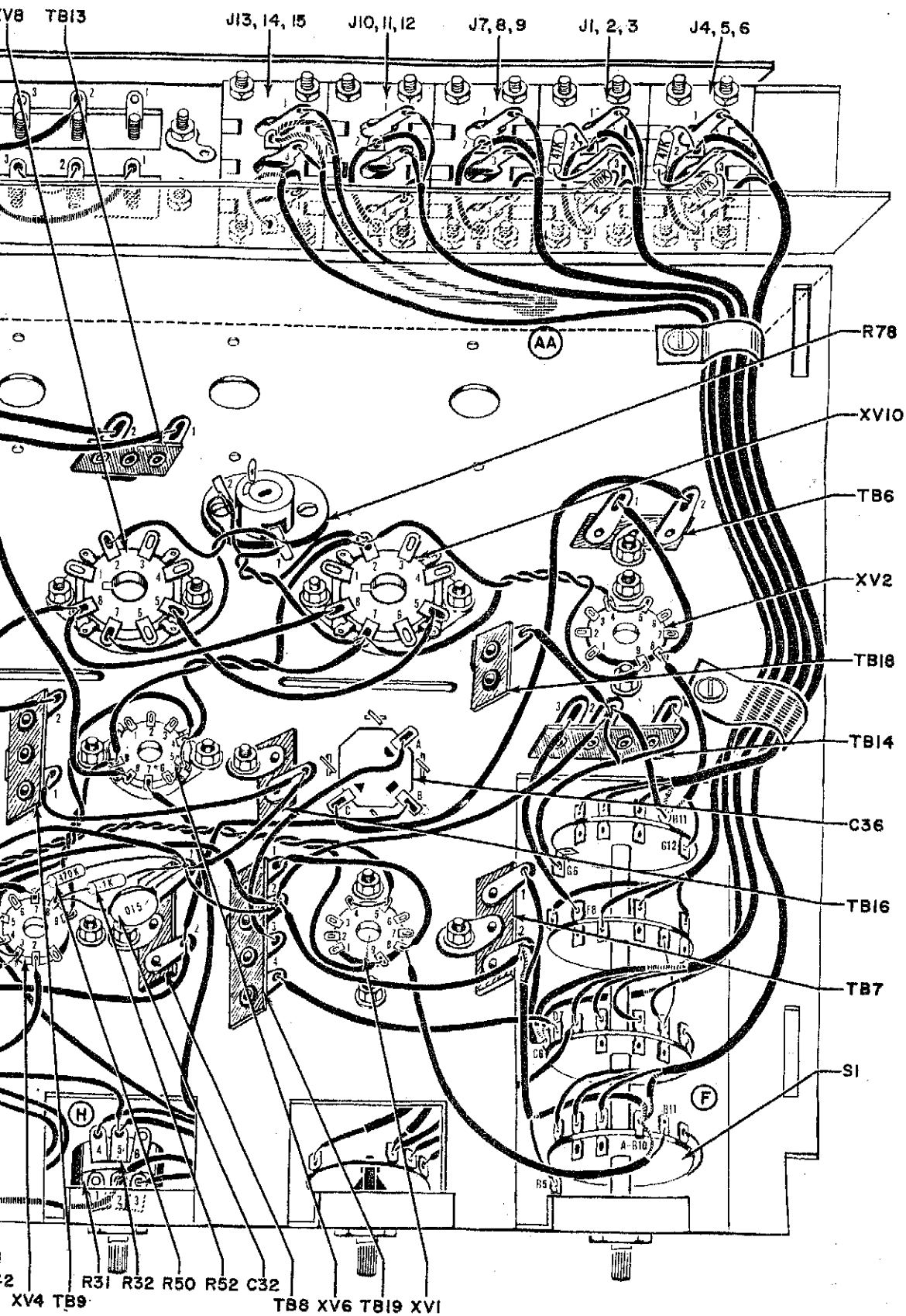

GROUND WIRE

WIRING FIG. 9

Ground C35 + C36 w/ 100K resistor

Capacitors: C39, R65, R69, R67, C19, XV7, R59, R63, XV5, R55, R53, TB11, C17, C35

Resistors: R61, R39, R37, TB24, TB10, C15, TB17, TB15, C16, TB9, R64

Capacitors: C4, C39, R65, R69, R67, C19, XV7, R59, R63, XV5, R55, R53, TB11, C17, C35

Resistors: R61, R39, R37, TB24, TB10, C15, TB17, TB15, C16, TB9, R64

Capacitors: C4, C39, R65, R69, R67, C19, XV7, R59, R63, XV5, R55, R53, TB11, C17, C35

Resistors: R61, R39, R37, TB24, TB10, C15, TB17, TB15, C16, TB9, R64

Capacitors: C4, C39, R65, R69, R67, C19, XV7, R59, R63, XV5, R55, R53, TB11, C17, C35

Resistors: R61, R39, R37, TB24, TB10, C15, TB17, TB15, C16, TB9, R64

Capacitors: C4, C39, R65, R69, R67, C19, XV7, R59, R63, XV5, R55, R53, TB11, C17, C35

Resistors: R61, R39, R37, TB24, TB10, C15, TB17, TB15, C16, TB9, R64

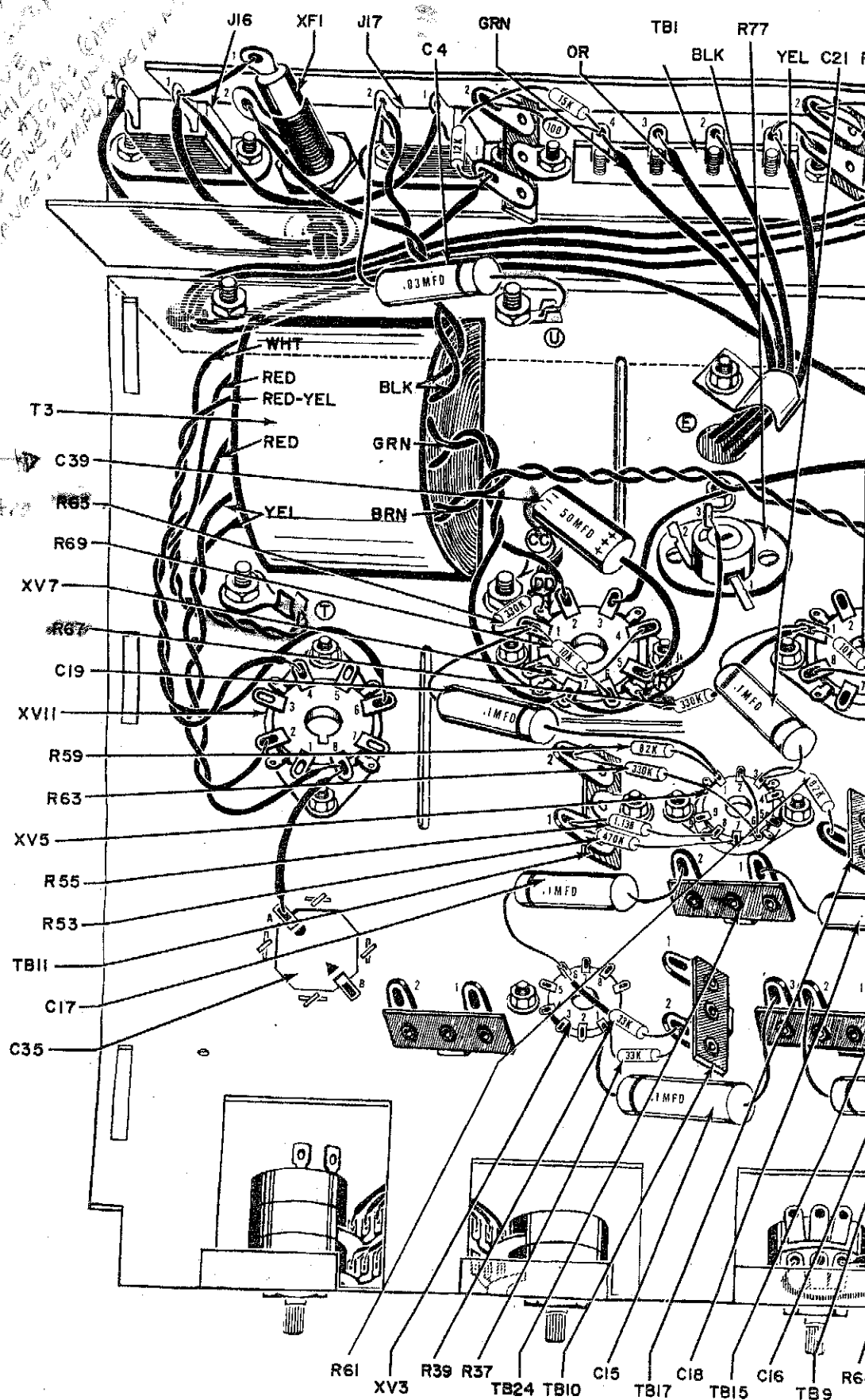

C/5-22 = coupling caps

BOTTOM WIRING

NOTES FROM CORRESPONDENCE W/ EICO OWNERS

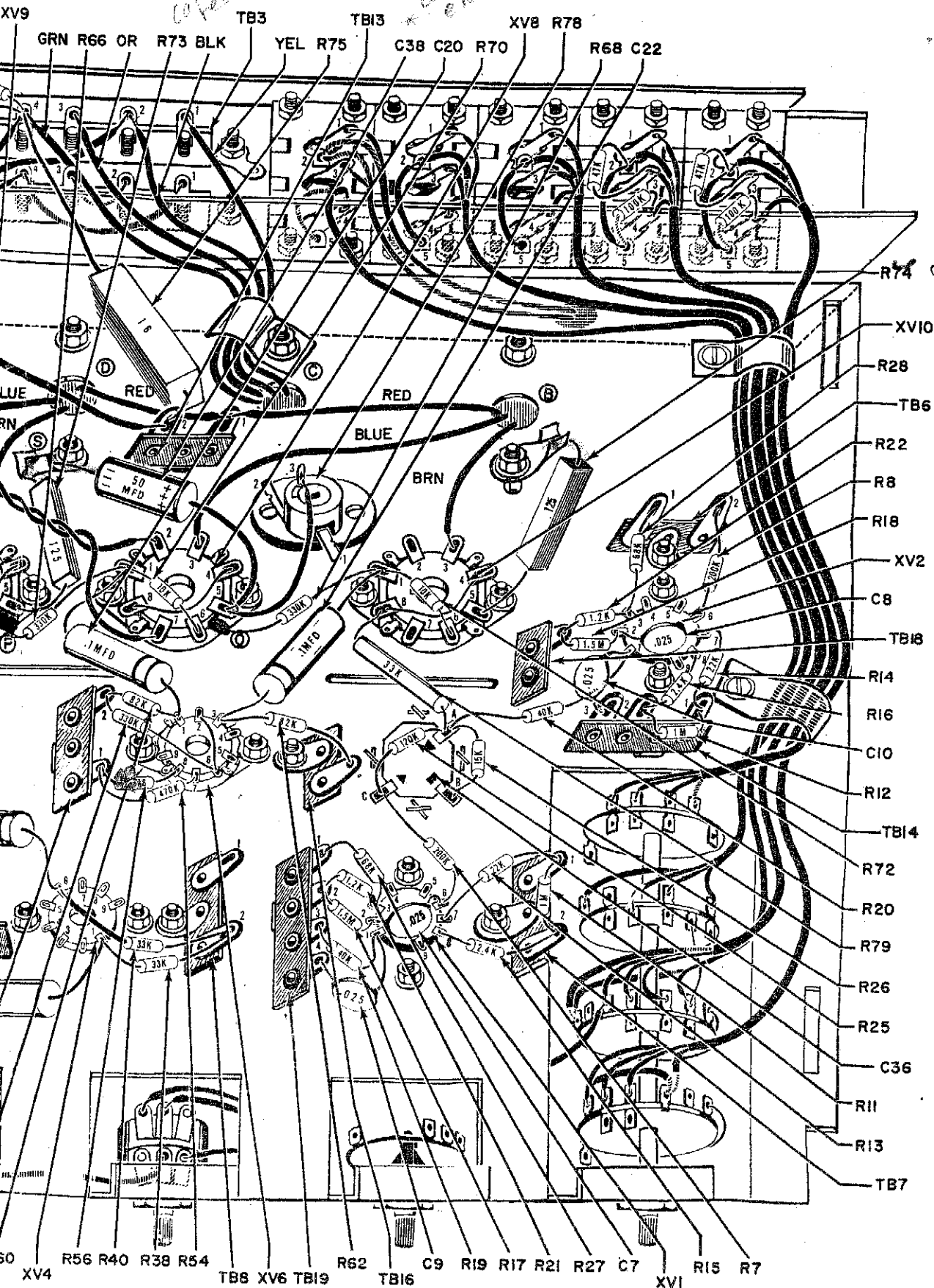

Cathode bypass
Cathode bypass resistor

R74 cathode bypass resistor

CONTINUED FIG. 10