

V1  
ECC85/6A08  
FM RF AND CONVERTER

V2  
6AU6A  
FM 1ST IF

V3  
6BA6  
AM-IF FM 2ND IF-1ST LIM.

V4  
6AU6A  
FM 3RD IF 2ND LIM.

V5  
12AL5  
FM RATIO DETECTOR

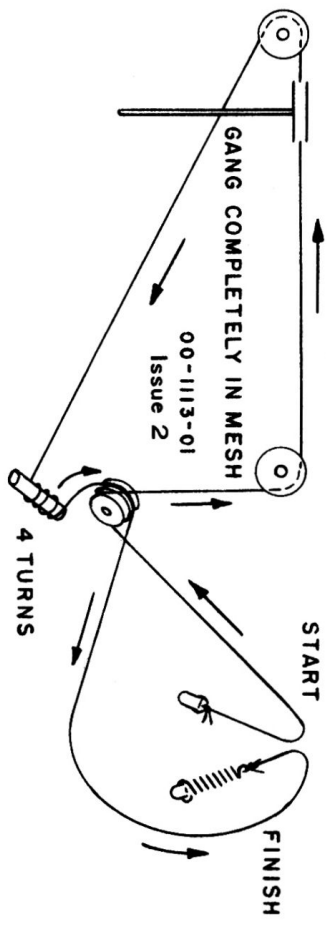
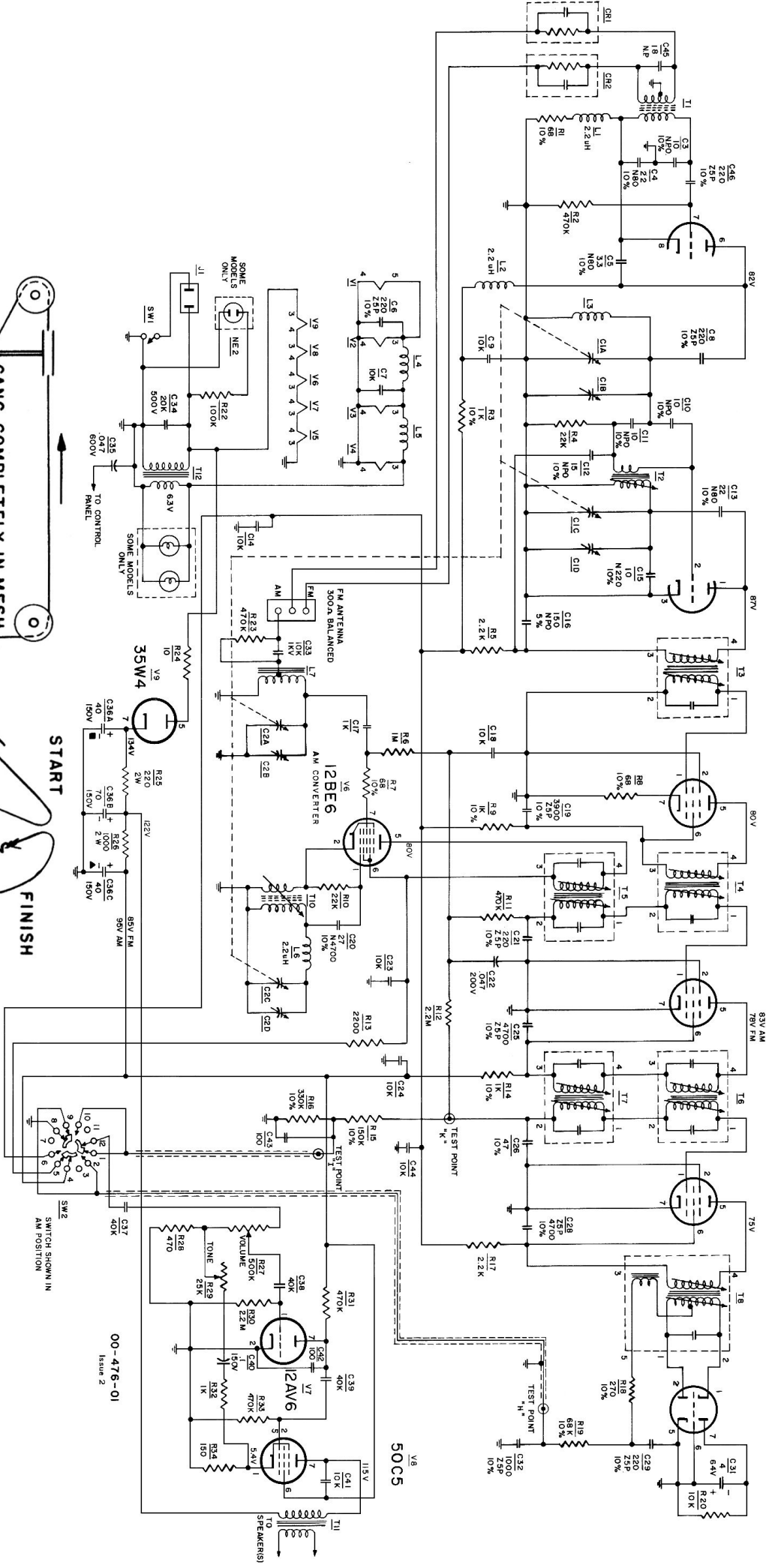

# ELECTROHOME AF-2

00-476-01  
Issue 2

# AM-FM TUNER ALIGNMENT INSTRUCTIONS

STEP	DUMMY ANTENNA	SIGNAL APPLIED TO	FREQ.	MODULATION	BAND SWITCH SETTING	DIAL POINTER SETTING	INDICATING METER	ADJUST	REMARKS	NOMINAL SENSITIVITY
1	.05 uf	Pin #1 V3 6BA6	455 Kc/s	400 C.P.S. AM at 30%	AM	600 Kc/s	AC-VTVM To Point "I"	T7 2nd AM-IF	Adjust for maximum output	3000 uv for 70 Mv. output
2	.05 uf	Pin #7 V6 12BE6	455 Kc/s	400 C.P.S. AM at 30%	AM	600 Kc/s	AC-VTVM To Point "I"	T5 1st AM-IF	Adjust for maximum output	100 uv for 70 Mv. output
3	390 ohms	AM Ant. Term. Strip	1400 Kc/s	400 C.P.S. AM at 30%	AM	1400 Kc/s	AC-VTVM To Point "I"	C2D and C2B Trimmers		20 uv for 70 Mv. output
4	390 ohms	AM Ant. Term. Strip	600 Kc/s	400 C.P.S. AM at 30%	AM	600 Kc/s	AC-VTVM To Point "I"	T10 AM-Osc.		Check for tracking.
5 Repeat steps 3 and 4, check band coverage at 535 Kc/s - 1650 Kc/s and for tracking at 950 Kc/s.										
6	-	Pin #1 V3 6BA6	10.7 Mc/s	Nil	FM	Point of no Inter- ference	DC-VTVM To Point "K"	T6, 3rd. FM-IF	Adjust for maximum meter deflection	10000 uv for 1V output
7	-	Pin #1 V3 6BA6	10.7 Mc/s	Nil	FM	Point of no Inter- ference	DC-VTVM To MX output	T8 FM Ratio Det. Primary (Bot)	Adjust for maximum meter deflection	1250 uv for 1V output
8	-	Pin #1 V3 6BA6	10.7 Mc/s	Nil	FM	Point of no Inter- ference	DC-VTVM To MX output	T8 FM Ratio Det. Second. (Top)	Adjust for zero voltage. NOTE **	-----
9	-	Pin #1 V2 6AU6A	10.7 Mc/s	Nil	FM	Point of no Inter- ference	DC-VTVM To Point "K"	T4 2nd FM-IF	Adjust for maximum meter deflection	160 uv for 1V output
10	-	C1A FM Gang	10.7 Mc/s	Nil	FM	Point of no Inter- ference	DC-VTVM To Point "K"	T3 1st FM-IF	Adjust for maximum meter deflection	-----
11	NOTE *	FM Ant. Term. Strip	90 Mc/s	400 C.P.S. FM 22.5 Kc/s Deviation	FM	90 Mc/s	AC-VTVM To Point "H"	T2 Slug and L3 Coil	Adjust for maximum output	3 uv for 200 Mv. output
12	NOTE *	FM Ant. Term. Strip	106 Mc/s	400 C.P.S. FM 22.5 Kc/s Deviation	FM	106 Mc/s	AC-VTVM To Point "H"	C1D and C1B Trimmers	Adjust for maximum output	3 uv for 200 Mv. output
13 Repeat steps 11 and 12 until output drops at least 20 db. when mod. is turned off.										3.0 uv
NOTE: To achieve more accurate alignment of FM IF's and ratio detector it is preferable to use a proper sweep generator and oscilloscope.										

**NOTES:**

\* For FM dummy antenna connect one 150 ohm carbon resistor from grounded side of sig. gen. to antenna terminal and one 120 ohm carbon resistor from hot side of signal generator to antenna terminal.

NOTE: Input to set is one half, output reading of signal generator.

\*\* With ground lead of DC-VTVM connected to junction of two 100 K resistors. To be temporarily connected in series across C31 (4 ufd CAP).

NOTE: THE CHASSIS IS DIRECTLY CONNECTED TO THE LINE AND AN ISOLATION TRANSFORMER MUST BE USED FOR ALIGNING AND TESTING.

