



Electro-Voice[®]



Professional 2 x 600 Watt Power Amplifier

SERVICE MANUAL



Table of Contents

- Safety and Service Instructions
-
- Warranty
-
- Technical specifications
-
- Measuring data
-
- Bill of materials
-
- Spare parts plan
-
- Circuit diagrams

Electro-Voice
600 Cecil Street,
Buchanan,
Michigan 49107

Phone 616/695-6831
Fax 616/695-1304
e-mail fspain@qtm.net

IMPORTANT SAFETY INSTRUCTIONS

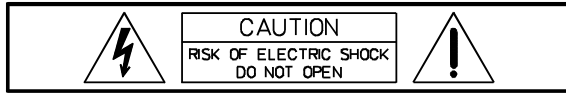

WARNING: TO REDUCE THE RISK OF FIRE OR ELECTRIC SHOCK,
DO NOT EXPOSE THIS APPLIANCE TO RAIN OR MOISTURE.
AVIS: RISQUÉ DE CHOC ELECTRIQUE. NE PAS OUVRIR.



The lightning flash with arrowhead symbol, within an equilateral triangle is intended to alert the user to the presence of uninsulated "dangerous voltage" within the product's enclosure that may be of sufficient magnitude to constitute a risk of electric shock to persons.



The exclamation point within an equilateral triangle is intended to alert the user to the presence of important operating and maintenance (servicing) instructions in the literature accompanying the appliance.

1. Read these instructions.
2. Keep these instructions.
3. Heed all warnings.
4. Follow all instructions.
5. Do not use this apparatus near water.
6. Clean only with a damp cloth.
7. Do not block any of the ventilation openings.
Install in accordance with the manufacturer's instructions.
8. Do not install near any heat sources such as radiators, heat registers, stoves, or other apparatus that produce heat.
9. Only use attachments/accessories specified by the manufacturer.
10. Refer all servicing to qualified service personnel. Servicing is required when the apparatus has been damaged in any way, such as power-supply cord or plug is damaged, liquid has been spilled or objects have fallen into the apparatus, the apparatus has been exposed to rain or moisture, does not operate normally, or has been dropped.

For US and CANADA only:

Do not defeat the safety purpose of the grounding-type plug. A grounding type plug has two blades and a third grounding prong. The wide blade or the third prong are provided for your safety. When the provided plug does not fit into your outlet, consult an electrician for replacement of the obsolete outlet.

IMPORTANT SERVICE INSTRUCTIONS

CAUTION: These servicing instructions are for use by qualified personnel only. To reduce the risk of electric shock, do not perform any servicing other than that contained in the Operating Instructions unless you are qualified to do so. Refer all servicing to qualified service personnel.

1. Security regulations as stated in the EN 60065 (VDE 0860 / IEC 65) and the CSA E65 - 94 have to be obeyed when servicing the appliance.
2. Use of a mains separator transformer is mandatory during maintenance while the appliance is opened, needs to be operated and is connected to the mains
3. Switch off the power before retrofitting any extensions, changing the mains voltage or the output voltage.
4. The minimum distance between parts carrying mains voltage and any accessible metal piece (metal enclosure), respectively between the mains poles has to be **3 mm** and needs to be minded at all times.
The minimum distance between parts carrying mains voltage and any switches or breakers that are not connected to the mains (secondary parts) has to be **6 mm** and needs to be minded at all times.
5. Replacing special components that are marked in the circuit diagram using the security symbol (Note) is only permissible when using original parts.
6. Altering the circuitry without prior consent or advice is not legitimate.
7. Any work security regulations that are applicable at the location where the appliance is being serviced have to be strictly obeyed. This applies also to any regulations about the work place itself.
8. All instructions concerning the handling of **MOS** - circuits have to be observed.

Note:  **SAFETY COMPONENT (HAS TO BE REPLACED WITH ORIGINAL PART ONLY)**

WARRANTY (Limited)

Electro-Voice products are guaranteed against malfunction due to defects in materials or workmanship for a specified period, as noted in the individual product-line statement(s) below, or in the individual product data sheet or owner's manual, beginning with the date of original purchase. If such malfunction occurs during the specified period, the product will be repaired or replaced (at our option) without charge. The product will be returned to the customer prepaid.

Exclusions and Limitations: The Limited Warranty does not apply to: (a) exterior finish or appearance; (b) certain specific items described in the individual product-line statement(s) below, or in the individual product data sheet or owner's manual; (c) Malfunction resulting from use or operation of the product other than as specified in the product data sheet or owner's manual; (d): malfunction resulting from misuse or abuse of the product; or (e): malfunction occurring at any time after repairs have been made to the product by anyone other than Electro-Voice or any of its authorized service representatives.

Obtaining Warranty Service: To obtain warranty service, a customer must deliver the product, prepaid, to Electro-Voice or any of its authorized service representatives together with proof of purchase of the product in the form of a bill of sale or receipted invoice. A list of authorized service representatives is available from Electro-Voice at 600 Cecil Street, Buchanan, MI 49107 (616-695-6831) and/or Electro-Voice West at 9130 Glenoaks Boulevard, Sun Valley, CA 91532 (213-875-1900).

Incidental and Consequential Damages Excluded: Product repair or replacement and return to the customer are the only remedies provided to the customer. Electro-Voice shall not be liable for any incidental or consequential damages including, without limitation, injury to persons or property or loss of use. Some states do not allow the exclusion or limitation of incidental or consequential damages so the above limitation or exclusion may not apply to you. **Other Rights:** This warranty gives you specific legal rights, and you may have other rights which vary from state to state.

Electro-Voice Electronics are guaranteed against malfunction due to defects in materials or workmanship for a period of three (3) years from the date of original purchase. Additional details are included in the Uniform Limited Warranty Statement.

Specifications subject to change without notice.

Electro-Voice®

600 Cecil Street, Buchanan, Michigan 49107, Phone 616/695-6831, Fax: 616/695-1304

TELEX/EVI Audio Canada, 705 Progress Ave. Unit 46 Toronto, Ontario, M1H 2x1, Canada, Phone: 800/881-1685, Fax: 877/522-2242

TELEX Communications A.G., Kellenstrasse 11, CH-2563 IPSACH, Switzerland, Phone: 011-41/32-51-6833, Fax: 011-41/32-51-1221

EVI Audio Deutschland GmbH, Hirschberger Ring 45, D-94315, Straubing, Germany, Phone: 011-49/9421-7060, Fax: 011-49/9421-706265

EVI Audio France S.A., Parc de Courcerin-Allee Lech Walesa, Lognes, f-77185 Marne La Vallee, France, Phone: 011-33/1-6480-0090, Fax: 011-33/1-6006-5103

EVI Audio Japan Ltd., 2-5-60 Izumi, Suginami-ku, Tokyo, Japan 168, Phone: 011-81/3-3325-7900, Fax: 011-81/3-3325-7789

EVI Audio (Aust.) Pty., Unit 24, Block C, Slough Business Park, Slough Ave., Silverwater, N.S.W 2141, Australia, Phone 011-61/2-648-3455,

Fax: 011-61/2-648-5585

EVI Audio (Hong Kong) Limited, Unit E & F, 21 /F., Luk Hop Industrial Bldg., 8 Luk Hop St., San Po Kong, Kowloon, Hong Kong, Phone: 011-852/351-3628,

Fax: 011 -852/351-3329

Technical Specifications: S1200, S900, Q44, Q66, Force, Eliminator, Altec Lansing 8140 & 8160
 Amplifier at rated conditions, both channels driven with 8Ω loads, unless otherwise specified.

	S900 / Q44 / Altec Lansing 8140 / Force			S1200 / Q66 / Altec Lansing 8160 / Eliminator		
	8Ω	4Ω	2Ω	8Ω	4Ω	2Ω
Load Impedance	8Ω	4Ω	2Ω	8Ω	4Ω	2Ω
Maximum Midband Output Power THD = 1%, 1kHz	280W	450W	650W	380W	600W	850W
Rated Output Power THD < 0.2%, 20Hz ... 20kHz	230W	350W	450W	300W	500W	650W
Max. Single Channel Output Power Dynamic-Headroom, IHF-A	340W	640W	720W	460W	880W	950W
Maximum Bridged Output Power THD = 1%, 1kHz	900W	1300W	-----	120W	1700W	-----
Maximum RMS Voltage Swing THD = 1%, 1kHz		56V			64V	
Voltage Gain at 1kHz		34dB			35dB	
Slew Rate at 1kHz		25V/μs			30V/μs	
Power Consumption at 1/8 maximum output power @ 4Ω		690W			870W	
Input Sensitivity at rated output power @ 4Ω, 1kHz					0dBu (775mV)	
THD at rated output power, MBW = 80kHz, 1kHz					< 0.05%	
IMD-SMPTE 60Hz, 7kHz					< 0.08%	
DIM30 3.15kHz, 15kHz					< 0.03%	
Crosstalk ref. 1kHz, at rated output power					< -80dB	
Frequency Response -1dB, ref. 1kHz					13Hz ... 45kHz	
Power Bandwidth THD = 1%, ref. 1kHz, half power @ 4Ω					10Hz ... 50kHz	
Input Impedance 20Hz ... 20kHz, balanced					20kΩ	
Damping Factor at 100Hz / 1kHz, 8Ω					> 300 / > 200	
Signal to Noise Ratio A-weighted					103dB	
Power Requirements					240V, 230V or 120 V, 50Hz ... 60Hz	
Protection					Audio limiters, High temperature, DC, HF, Back-EMF, Peak current limiters, Inrush current limiters, Turn-on delay	
Cooling					Front-to-rear, 3-stage-fans	
Safety Class					I	
Dimensions (W x H x D), mm					483 x 132.5 x 385.5	
Weight		15kg			16kg	

MEASUREMENT SPECIFICATIONS: Force & Eliminator power amplifiers

printed board assembly names and their corresponding EDP-No.:

Force : 84177

Eliminator : 84178

printed board assembly	index
Main PCB	1
Supply PCB	4
Input PCB	2
LED PCB	3

measuring condition; if not otherwise specified:

- tolerance of measured values: $\Delta X = \pm 1.5 \text{ dB}$
- measuring frequency: $f = 1 \text{ kHz}$
- stated levels refer to: $U = 775 \text{ mV (0 dBu)}$
- level controls set to their clockwise limits
- pin assignment of the XLR-type connectors:
 - PIN 1: ground / shielding
 - PIN 2: + INPUT
 - PIN 3: - INPUT
- source resistance for the induction via the XLR-type connector: $R(Q) = 50 \Omega$
- the AMPLIFIER PCB printed board assembly is provided with **service connectors**

CNS1		CNS2		CNRC	
PIN	assignment	PIN	assignment	PIN	assignment
1	-Vcc	1	LIM A Switch	1	LIM Out A
2	BIAS +A	2	-15V	2	LIM Out B
3	BIAS -A	3	LIM B Switch	3	Standby via RC
4	FAN Voltage	4	+15V	4	Standby LED
5	+Vcc	5	AGND	5	-Vss
6	BIAS +B	6	Speaker Out A	6	+Vss
7	BIAS -B	7	Relais/Protect	7	n.c.
8	Temp Heatsink	8	Speaker Out B	8	n.c.

1. **Operation voltage:** $U(B) = 120 \text{ V, } 50 \text{ Hz ... } 60 \text{ Hz}$
2. **Deviation limit of the operation voltage:** $-30 \% \text{ ... } +10 \%$
3. **Power consumption (both channels driven) $f = 1 \text{ kHz}$**

	Force	Eliminator
idling power consumption	30-60W	40-80W
nominal power consumption ($R_L=4\Omega$)	1400W	1900W
standard power consumption ($R_L=4\Omega$)	430W	600W
maximum power consumption ($R_L=4\Omega$)	1650W	2100W
power consumption at 1/8 of the maximum output power	690W	870W

4. Adjustments

4.1 IDLING CURRENT ADJUSTMENT

Connect the DC-volt meter at the BIAS measuring points (see service connector) and adjust the idling current via the trim potentiometer VR101/VR301 (on the main PCB printed board assembly). Adjust both channels of the power amplifier A&B to a value of $U(\text{DC}) = 7.5 \text{ mV}$. Adjusting the idling current setting has to be

performed at normal room temperature. In case the power amplifier had been operated before, it has to be given several hours for cooling off.

4.2 VCA - OFFSET

Periodically (rhythmical) opening and short-circuiting the CNS2.1 and CNS2.2 on the main PCB printed board assembly for channel A; respectively CNS2.3 and CNS2.2 for channel B. Using VR100 respectively VR300 to adjust the power amplifier outputs to their minimum offset (with oscilloscope to minimal peak value or to the audible minimal volume setting).

5. Testing of functions

5.1 OUTPUT - offset voltage

DC-voltage measuring at the SPEAKER A/B outputs with $U(\text{DC}) \leq \pm 10 \text{ mV}$.

5.2 LIMITER

5.2.1 damping test

Channels separately driven with a 1 kHz signal up to $U(\text{A}) = 49 \text{ volts}$, respectively $U(\text{A}) = 42.2 \text{ volts}$ (without load). Increase the input voltage by 10 dB. The LIMITER LED lights and the output voltage increases by about 2 dB to approx. 64 volts, respectively 56 volts; with slight clipping. The distortion rate of the limited signal is at $\text{THD} = 1.0 \dots 1.5 \%$. Increasing the input signal up to a value of +20 dBu should not result in remarkably higher clipping.

5.2.2 attack and release times

perform the test of both power amplifier channels separately: testing without load resistors

- 1.) Drive the power amplifier input with a burst signal ($f = 1 \text{ kHz}$, 10 cycles, rate: $\approx 0.5 \text{ sec.}$) and $U(\text{E}) = +10 \text{ dBu}$.
- 2.) Use an oscilloscope to monitor the output signal. After 3 - 4 signal periods, the limiter controlled the major distortion down to a minor residual distortion ($\text{THD} = 1.0 \dots 1.5 \%$).
attack time: 3 - 4 ms release time: 30 - 40 ms

5.3 POWER-ON DELAY

Signal present at the power amplifier input. Use the power-on switch to switch the power amplifier's power on. Approximately 2 seconds after switching the power on, the signal is present at the amplifier's output.

5.4 FAN CONTROL

Upon powering-on the power amplifier, the fans will run for about 2 seconds and then stop; presuming that the amplifier's temperature is not too high. In idling condition (power-on, no signal present) the fans are switched between the SLOW and OFF (0 V) mode, depending on the temperature of the heat sink. When CNS1.8 is connected via a 51 kohms resistor with +15 V, the fans will run in SLOW mode. Fan-voltage of 16.8 V DC measured between Pin CNS2.4 and Pin CNS1.4. Disconnecting the plug CN5 results in the fans running at FAST speed. Fan-voltage of 28 V DC measured between Pin CNS2.4 and Pin CNS1.4.

5.5 SOAR PROTECTION CIRCUIT TEST

Channels separately driven on 4 Ω up to 49 volts, respectively 42.2 volts. Parallel connect a 1 Ω resistor. The protection circuit reacts and tries continuously to re-start! The protect-LED lights. Repeat the test with a 2 Ω resistor; the power amplifier should not switch off.

5.6 SHORT-CIRCUIT CURRENT-LIMITING TEST

perform the test for both power amplifier channels separately and without load:

- drive the channel with a burst signal ($f = 1 \text{ kHz}$, 1 - 3 cycles, rate $\approx 1 \text{ sec.}$) with $U(\text{E}) = 0 \text{ dBu}$
- connect a load resistor of 1 Ω
- the short-circuit current-limiter limits the output voltage at the load resistor symmetrically (monitor via oscilloscope) to a peak voltage value of 35 V, respectively 27 V (approx. 35 A respectively 27 A maximum peak output current).

5.7 DC-VOLTAGE PROTECTION CIRCUIT TEST

perform the test for both power amplifier channels separately:

- drive the power amplifier with a test signal ($f = 7 \text{ Hz}$) and without load

11. Noise interference

- U(F) = external voltage un-weighted with B = 22 Hz ... 22 kHz, effective value (IEC 268-1)
- U(G) = noise voltage, frequency-weighting filter according to CCIR-468-3, quasi peak weighted (IEC 268-1)
- U(A) = interference voltage A-weighted, dB(A), effective value (IEC 268-1)
- Signal-to-noise ratio referring to maximum output voltage at 4 Ω and A-weighted interference voltage

power amp	output	U(F) dBu	U(G) dBu	U(A) dBu	GAIN dB	INPUT(A) dBu	S/N-R. dB	remark
Force	SPEAKER OUT A&B	-66.2	-55.2	-68.2	34	-102.2	103	INPUT A&B R(Q) = 50Ω
Eliminator	SPEAKER OUT A&B	-65	-54	-67	35	-102	103	INPUT A&B R(Q) = 50Ω
Force	SPEAKER OUT A&B	-68.2	-57.2	-70.2	/	/	/	INPUT A&B R(Q) = 50Ω
Eliminator	SPEAKER OUT A&B	-68	-57	-70	/	/	/	INPUT A&B R(Q) = 50Ω

12. Dimensions and weight

power amplifier	weight	dimensions in mm
Force	15kg	483 x 132.5 x 385.5
Eliminator	16kg	483 x 132.5 x 385.5

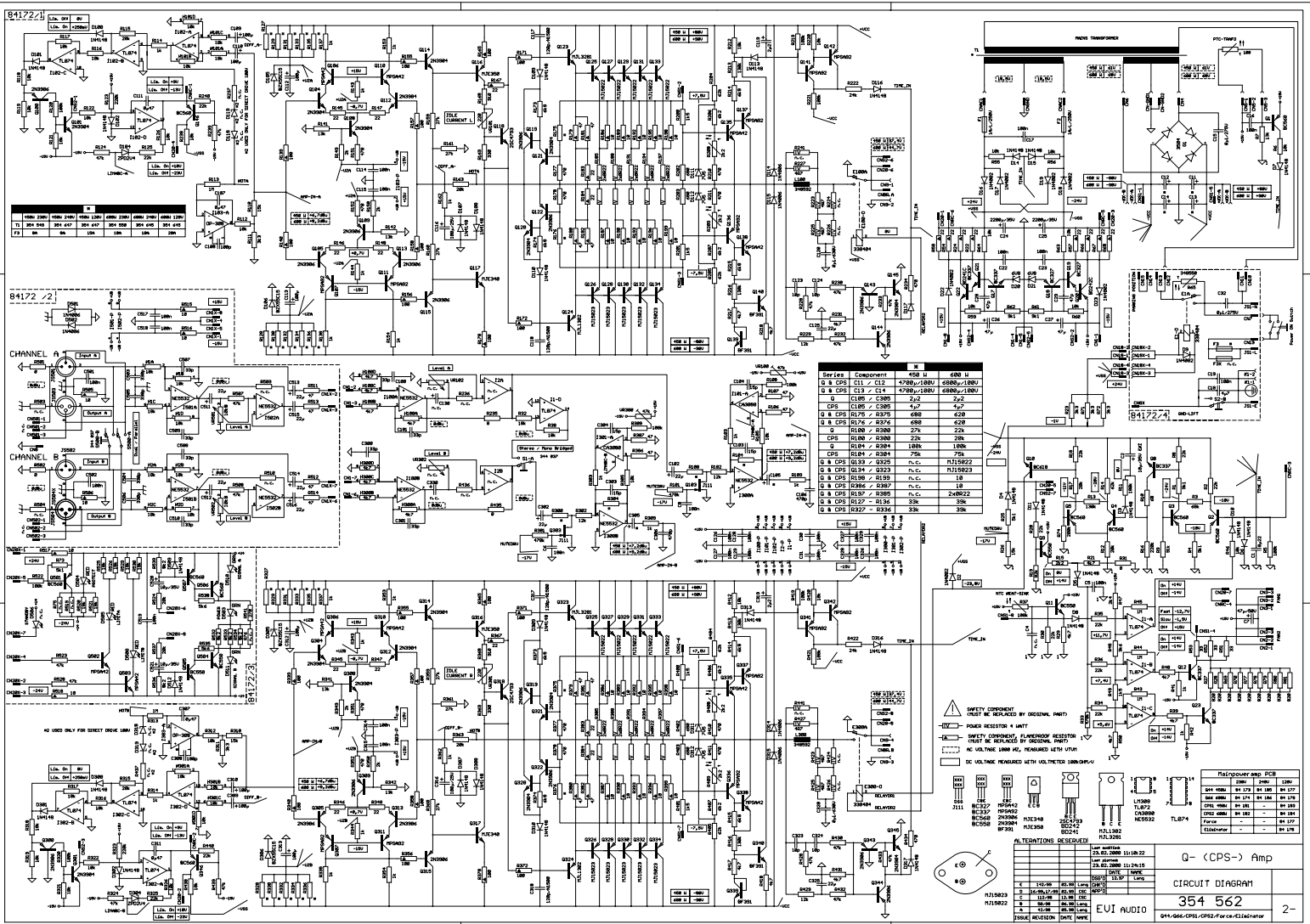

Part	Value	Part	Value
11	100K	21	100K
12	100K	22	100K
13	100K	23	100K
14	100K	24	100K
15	100K	25	100K
16	100K	26	100K
17	100K	27	100K
18	100K	28	100K
19	100K	29	100K
20	100K	30	100K

Rev (ex)	Component	428 U	428 U
D & CPS	C11 - C17	4700p/100V	6800p/100V
D & CPS	C18 - C24	4700p/100V	4800p/100V
D	C25	2u2	2u2
D & CPS	C26 - C30	5u7	5u7
D & CPS	R175 - R375	680	620
D	R376	680	620
D	R377	500	500
CPS	R378 - R380	22k	20k
D	R381 - R383	100k	100k
CPS	R384 - R384	75k	75k
D	R385 - R385	100k	100k
D & CPS	Q134 - Q223	P.C.C.	7115023
D & CPS	R189 - R189	P.C.C.	18
D & CPS	R186 - R187	P.C.C.	18
D & CPS	R187 - R187	P.C.C.	200022
D & CPS	R122 - R124	33k	33k
D & CPS	R327 - R326	33k	33k

- ⚠ SAFETY WARNING: MUST BE REPLACED BY ORIGINAL PART
- ⚡ POWER RESISTOR - 1 UNIT
- ⚠ SAFETY WARNING: A FUSIBLE RESISTOR MUST BE REPLACED BY ORIGINAL PART
- ⚡ AC VOLTAGE SOURCE AND RESISTOR SETS UP
- ⚡ DC VOLTAGE PROVIDED WITH VOLTAGE SOURCE

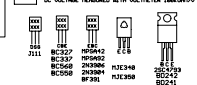

Part	Value	Part	Value
R11802	100K	R11803	100K
R11804	100K	R11805	100K
R11806	100K	R11807	100K
R11808	100K	R11809	100K
R11810	100K	R11811	100K
R11812	100K	R11813	100K
R11814	100K	R11815	100K
R11816	100K	R11817	100K
R11818	100K	R11819	100K
R11820	100K	R11821	100K
R11822	100K	R11823	100K
R11824	100K	R11825	100K
R11826	100K	R11827	100K
R11828	100K	R11829	100K
R11830	100K	R11831	100K
R11832	100K	R11833	100K
R11834	100K	R11835	100K
R11836	100K	R11837	100K
R11838	100K	R11839	100K
R11840	100K	R11841	100K
R11842	100K	R11843	100K
R11844	100K	R11845	100K
R11846	100K	R11847	100K
R11848	100K	R11849	100K
R11850	100K	R11851	100K
R11852	100K	R11853	100K
R11854	100K	R11855	100K
R11856	100K	R11857	100K
R11858	100K	R11859	100K
R11860	100K	R11861	100K
R11862	100K	R11863	100K
R11864	100K	R11865	100K
R11866	100K	R11867	100K
R11868	100K	R11869	100K
R11870	100K	R11871	100K
R11872	100K	R11873	100K
R11874	100K	R11875	100K
R11876	100K	R11877	100K
R11878	100K	R11879	100K
R11880	100K	R11881	100K
R11882	100K	R11883	100K
R11884	100K	R11885	100K
R11886	100K	R11887	100K
R11888	100K	R11889	100K
R11890	100K	R11891	100K
R11892	100K	R11893	100K
R11894	100K	R11895	100K
R11896	100K	R11897	100K
R11898	100K	R11899	100K
R11900	100K	R11901	100K
R11902	100K	R11903	100K
R11904	100K	R11905	100K
R11906	100K	R11907	100K
R11908	100K	R11909	100K
R11910	100K	R11911	100K
R11912	100K	R11913	100K
R11914	100K	R11915	100K
R11916	100K	R11917	100K
R11918	100K	R11919	100K
R11920	100K	R11921	100K
R11922	100K	R11923	100K
R11924	100K	R11925	100K
R11926	100K	R11927	100K
R11928	100K	R11929	100K
R11930	100K	R11931	100K
R11932	100K	R11933	100K
R11934	100K	R11935	100K
R11936	100K	R11937	100K
R11938	100K	R11939	100K
R11940	100K	R11941	100K
R11942	100K	R11943	100K
R11944	100K	R11945	100K
R11946	100K	R11947	100K
R11948	100K	R11949	100K
R11950	100K	R11951	100K
R11952	100K	R11953	100K
R11954	100K	R11955	100K
R11956	100K	R11957	100K
R11958	100K	R11959	100K
R11960	100K	R11961	100K
R11962	100K	R11963	100K
R11964	100K	R11965	100K
R11966	100K	R11967	100K
R11968	100K	R11969	100K
R11970	100K	R11971	100K
R11972	100K	R11973	100K
R11974	100K	R11975	100K
R11976	100K	R11977	100K
R11978	100K	R11979	100K
R11980	100K	R11981	100K
R11982	100K	R11983	100K
R11984	100K	R11985	100K
R11986	100K	R11987	100K
R11988	100K	R11989	100K
R11990	100K	R11991	100K
R11992	100K	R11993	100K
R11994	100K	R11995	100K
R11996	100K	R11997	100K
R11998	100K	R11999	100K
R12000	100K	R12001	100K
R12002	100K	R12003	100K
R12004	100K	R12005	100K
R12006	100K	R12007	100K
R12008	100K	R12009	100K
R12010	100K	R12011	100K
R12012	100K	R12013	100K
R12014	100K	R12015	100K
R12016	100K	R12017	100K
R12018	100K	R12019	100K
R12020	100K	R12021	100K
R12022	100K	R12023	100K
R12024	100K	R12025	100K
R12026	100K	R12027	100K
R12028	100K	R12029	100K
R12030	100K	R12031	100K
R12032	100K	R12033	100K
R12034	100K	R12035	100K
R12036	100K	R12037	100K
R12038	100K	R12039	100K
R12040	100K	R12041	100K
R12042	100K	R12043	100K
R12044	100K	R12045	100K
R12046	100K	R12047	100K
R12048	100K	R12049	100K
R12050	100K	R12051	100K
R12052	100K	R12053	100K
R12054	100K	R12055	100K
R12056	100K	R12057	100K
R12058	100K	R12059	100K
R12060	100K	R12061	100K
R12062	100K	R12063	100K
R12064	100K	R12065	100K
R12066	100K	R12067	100K
R12068	100K	R12069	100K
R12070	100K	R12071	100K
R12072	100K	R12073	100K
R12074	100K	R12075	100K
R12076	100K	R12077	100K
R12078	100K	R12079	100K
R12080	100K	R12081	100K
R12082	100K	R12083	100K
R12084	100K	R12085	100K
R12086	100K	R12087	100K
R12088	100K	R12089	100K
R12090	100K	R12091	100K
R12092	100K	R12093	100K
R12094	100K	R12095	100K
R12096	100K	R12097	100K
R12098	100K	R12099	100K
R12100	100K	R12101	100K
R12102	100K	R12103	100K
R12104	100K	R12105	100K
R12106	100K	R12107	100K
R12108	100K	R12109	100K
R12110	100K	R12111	100K
R12112	100K	R12113	100K
R12114	100K	R12115	100K
R12116	100K	R12117	100K
R12118	100K	R12119	100K
R12120	100K	R12121	100K
R12122	100K	R12123	100K
R12124	100K	R12125	100K
R12126	100K	R12127	100K
R12128	100K	R12129	100K
R12130	100K	R12131	100K
R12132	100K	R12133	100K
R12134	100K	R12135	100K
R12136	100K	R12137	100K
R12138	100K	R12139	100K
R12140	100K	R12141	100K
R12142	100K	R12143	100K
R12144	100K	R12145	100K
R12146	100K	R12147	100K
R12148	100K	R12149	100K
R12150	100K	R12151	100K
R12152	100K	R12153	100K
R12154	100K	R12155	100K
R12156	100K	R12157	100K
R12158	100K	R12159	100K
R12160	100K	R12161	100K
R12162	100K	R12163	100K
R12164	100K	R12165	100K
R12166	100K	R12167	100K
R12168	100K	R12169	100K
R12170	100K	R12171	100K
R12172	100K	R12173	100K
R12174	100K	R12175	100K
R12176	100K	R12177	100K
R12178	100K	R12179	100K
R12180	100K	R12181	100K
R12182	100K	R12183	100K
R12184	100K	R12185	100K
R12186	100K	R12187	100K
R12188	100K	R12189	100K
R12190	100K	R12191	100K
R12192	100K	R12193	100K
R12194	100K	R12195	100K
R12196	100K	R12197	100K
R12198	100K	R12199	100K
R12200	100K	R12201	100K
R12202	100K	R12203	100K
R12204	100K	R12205	100K
R12206	100K	R12207	100K
R12208	100K	R12209	100K
R12210	100K	R12211	100K
R12212	100K	R12213	100K
R12214	100K	R12215	100K
R12216	100K	R12217	100K
R12218	100K	R12219	100K
R12220	100K	R12221	100K
R12222	100K	R12223	100K
R12224	100K	R12225	100K
R12226	100K	R12227	100K
R12228	100K	R12229	

Bill of materials

170099	ELIMINATOR 2X600W
---------------	--------------------------

Ref. No.	Part no.	Description
----------	----------	-------------

Accessories		
--------------------	--	--

358091	owner's manual
354617	power cord

Mechanical parts		
-------------------------	--	--

B0010	341343	speaker socket 4-pole
G0010	343270	rectifier GBPC-P 3504
S0010	346720	power switch
	341382	push button black
	357958	rotary knob
	337044	plug, hole
	349528	plug, hole, SPEAKON
	348415	fan dc 24V
	337053	plastic bag
	306482	carton
	355741	filler, carton
	355742	filler, carton
	358067	front panel Eliminator
	358066	rear panel Eliminator
	351353	cover chassis

Electronical parts		
---------------------------	--	--

354645	mains transformer 120/240V
348805	safety component PTC
348341	connector female 3-pin

841788		
pcb assy 84178		

CNAC1	343516	connector 4.8mm
CNAC2	343516	connector 4.8mm
CNGND	343516	connector 4.8mm
CNGN1	330269	connector 6.3mm
CN001	344862	connector male 8-pin
CN002	348334	connector male 3-pin
CN003	348334	connector male 3-pin
CN005	348334	connector male 3-pin
CN007	330269	connector 6.3mm
CN01X	344862	connector male 8-pin
CN010	330269	connector 6.3mm
CN011	330269	connector 6.3mm
CN012	330269	connector 6.3mm
CN013	330269	connector 6.3mm
CN018	341937	connector male 4-pin
CN019	330269	connector 6.3mm
CN020	344862	connector male 8-pin
CN08X	343516	connector 4.8mm
CN18X	341937	connector male 4-pin
CN20X	344862	connector male 8-pin
C0001	342923	cap mylar 220nF
C0002	307445	cap electrolytic 10uF/35V

Ref. No.	Part no.	Description
C0005	329021	cap ceramic 100nF
C0006	329021	cap ceramic 100nF
C0007	343530	cap electrolytic 47uF/50V
C0008	329021	cap ceramic 100nF
C0011	354564	cap electr. 6800uF/100V
C0012	354564	cap electr. 6800uF/100V
C0013	354564	cap electr. 6800uF/100V
C0014	354564	cap electr. 6800uF/100V
C0015	341714	safety cap 100nF/275V
C0016	329021	cap ceramic 100nF
C0017	329021	cap ceramic 100nF
C0018	327366	cap electrolytic 4.7uF/50V
C0019	329021	cap ceramic 100nF
C0022	329021	cap ceramic 100nF
C0023	329021	cap ceramic 100nF
C0024	335935	cap electrolytic 2200uF/35V
C0025	335935	cap electrolytic 2200uF/35V
C0026	343530	cap electrolytic 47uF/50V
C0027	343530	cap electrolytic 47uF/50V
C0028	301524	cap ceramic 47pF
C0029	301524	cap ceramic 47pF
C0030	329021	cap ceramic 100nF
C0031	329021	cap ceramic 100nF
C0032	341714	safety cap 100nF/275V
C0100	301558	cap ceramic 33pF
C0101	301558	cap ceramic 33pF
C0102	301478	cap electrolytic 22uF/63V
C0103	335787	cap ceramic 15pF
C0104	335787	cap ceramic 15pF
C0105	301458	cap electrolytic 2.2uF/63V
C0106	327390	cap mylar 470pF
C0107	340988	cap mylar 470nF
C0108	301530	cap ceramic 100pF
C0109	343532	cap electrolytic 100uF/25V
C0110	343532	cap electrolytic 100uF/25V
C0111	340988	cap mylar 470nF
C0112	343532	cap electrolytic 100uF/25V
C0113	343532	cap electrolytic 100uF/25V
C0114	329021	cap ceramic 100nF
C0115	329021	cap ceramic 100nF
C0116	343532	cap electrolytic 100uF/25V
C0117	351994	cap ceramic 120pF
C0118	351994	cap ceramic 120pF
C0119	301458	cap electrolytic 2.2uF/63V
C0120	341714	safety cap 100nF/275V
C0123	301519	cap ceramic 10pF
C0124	301519	cap ceramic 10pF
C0125	301474	cap bip electr. 22uF/16V
C0126	329021	cap ceramic 100nF
C0127	329021	cap ceramic 100nF
C0128	329021	cap ceramic 100nF
C0129	329021	cap ceramic 100nF
C0300	301558	cap ceramic 33pF
C0301	301558	cap ceramic 33pF

Ref. No.	Part no.	Description
C0302	301478	cap electrolytic 22uF/63V
C0303	335787	cap ceramic 15pF
C0304	335787	cap ceramic 15pF
C0305	301458	cap electrolytic 2.2uF/63V
C0306	327390	cap mylar 470pF
C0307	340988	cap mylar 470nF
C0308	301530	cap ceramic 100pF
C0309	343532	cap electrolytic 100uF/25V
C0310	343532	cap electrolytic 100uF/25V
C0311	340988	cap mylar 470nF
C0312	343532	cap electrolytic 100uF/25V
C0313	343532	cap electrolytic 100uF/25V
C0314	329021	cap ceramic 100nF
C0315	329021	cap ceramic 100nF
C0316	343532	cap electrolytic 100uF/25V
C0317	351994	cap ceramic 120pF
C0318	351994	cap ceramic 120pF
C0319	301458	cap electrolytic 2.2uF/63V
C0320	341714	safety cap 100nF/275V
C0323	301519	cap ceramic 10pF
C0324	301519	cap ceramic 10pF
C0325	301474	cap bip electr. 22uF/16V
C0326	329021	cap ceramic 100nF
C0327	329021	cap ceramic 100nF
C0328	329021	cap ceramic 100nF
C0329	329021	cap ceramic 100nF
C0501	329021	cap ceramic 100nF
C0502	329021	cap ceramic 100nF
C0503	301543	cap ceramic 330pF
C0504	301543	cap ceramic 330pF
C0505	301543	cap ceramic 330pF
C0506	301543	cap ceramic 330pF
C0507	301558	cap ceramic 33pF
C0508	301558	cap ceramic 33pF
C0509	301558	cap ceramic 33pF
C0510	301558	cap ceramic 33pF
C0511	340523	cap electrolytic 22uF/16V
C0512	340523	cap electrolytic 22uF/16V
C0513	340523	cap electrolytic 22uF/16V
C0514	340523	cap electrolytic 22uF/16V
C0515	340523	cap electrolytic 22uF/16V
C0516	340523	cap electrolytic 22uF/16V
C0517	329021	cap ceramic 100nF
C0518	329021	cap ceramic 100nF
C0519	329021	cap ceramic 100nF
C0520	340522	cap electrolytic 10uF/35
C0521	340522	cap electrolytic 10uF/35
D0002	304360	diode 1N 4002
D0003	301254	diode 1N 4148
D0004	301254	diode 1N 4148
D0005	301254	diode 1N 4148
D0006	301254	diode 1N 4148
D0007	301254	diode 1N 4148
D0008	301254	diode 1N 4148

Ref. No.	Part no.	Description
D0009	304360	diode 1N 4002
D0010	301254	diode 1N 4148
D0011	301254	diode 1N 4148
D0014	301254	diode 1N 4148
D0015	301254	diode 1N 4148
D0016	304360	diode 1N 4002
D0017	304360	diode 1N 4002
D0018	304360	diode 1N 4002
D0019	304360	diode 1N 4002
D0020	304992	diode zener ZPD 6V8
D0021	304992	diode zener ZPD 6V8
D0022	304360	diode 1N 4002
D0023	304360	diode 1N 4002
D0100	301254	diode 1N 4148
D0101	301254	diode 1N 4148
D0102	301254	diode 1N 4148
D0104	329511	diode zener 2V4
D0105	309450	diode zener BZX 55C 15V
D0106	309450	diode zener BZX 55C 15V
D0107	301254	diode 1N 4148
D0108	301254	diode 1N 4148
D0109	301254	diode 1N 4148
D0110	301254	diode 1N 4148
D0111	307916	diode zener ZPD 7V5
D0112	307916	diode zener ZPD 7V5
D0113	301254	diode 1N 4148
D0114	304360	diode 1N 4002
D0115	304360	diode 1N 4002
D0116	301254	diode 1N 4148
D0117	301254	diode 1N 4148
D0300	301254	diode 1N 4148
D0301	301254	diode 1N 4148
D0302	301254	diode 1N 4148
D0304	329511	diode zener 2V4
D0305	309450	diode zener BZX 55C 15V
D0306	309450	diode zener BZX 55C 15V
D0307	301254	diode 1N 4148
D0308	301254	diode 1N 4148
D0309	301254	diode 1N 4148
D0310	301254	diode 1N 4148
D0311	307916	diode zener ZPD 7V5
D0312	307916	diode zener ZPD 7V5
D0313	301254	diode 1N 4148
D0314	304360	diode 1N 4002
D0315	304360	diode 1N 4002
D0316	301254	diode 1N 4148
D0317	301254	diode 1N 4148
D0501	304360	diode 1N 4002
D0502	304360	diode 1N 4002
D0503	354547	led green
D0504	354546	led red
D0505	354546	led red
D0508	354546	led red
D0509	301254	diode 1N 4148

Ref. No.	Part no.	Description
D0510	354547	led green
D0511	354547	led green
D0512	301254	diode 1N 4148
E0001	354859	relay 24V
E0100	354859	relay 24V
E0300	354859	relay 24V
F0001	302582	fuse 1A slow blow
F0002	302582	fuse 1A slow blow
F0003	348853	fuse 20A slow blow
H0001	343457	res.network RKL 8A 103J
H0002	343457	res.network RKL 8A 103J
H0100	343456	res.network RKL 8A 472J
H0101	343457	res.network RKL 8A 103J
H0300	343456	res.network RKL 8A 472J
H0301	343457	res.network RKL 8A 103J
I0001	332985	IC TL 074 CN
I0100	327197	IC NE 5532 N
I0101	307421	IC CA 3080 E
I0102	332985	IC TL 074 CN
I0103	338359	IC LM 308 A
I0300	327197	IC NE 5532 N
I0301	307421	IC CA 3080 E
I0302	332985	IC TL 074 CN
I0303	338359	IC LM 308 A
I0501	327197	IC NE 5532 N
I0502	327197	IC NE 5532 N
JS001	338835	connector male mains
JS501	351815	xlr connector female
JS502	351815	xlr connector female
JS503	351816	xlr connector male 3-pin
JS504	351816	xlr connector male 3-pin
L0100	348592	coil 2.5uH
L0300	348592	coil 2.5uH
Q0001	306928	transistor BC 560 C
Q0002	306928	transistor BC 560 C
Q0003	306928	transistor BC 560 C
Q0004	306928	transistor BC 560 C
Q0005	306928	transistor BC 560 C
Q0008	307150	transistor BC 337-25
Q0009	301184	transistor BC 550 B
Q0010	348591	transistor BC 618
Q0011	301184	transistor BC 550 B
Q0012	307150	transistor BC 337-25
Q0017	307150	transistor BC 337-25
Q0018	307430	transistor BC 327-25
Q0019	307430	transistor BC 327-25
Q0020	301235	transistor BD 242 B
Q0021	307150	transistor BC 337-25
Q0022	301236	transistor BD 241 B
Q0023	307150	transistor BC 337-25
Q0100	348421	transistor 2N 3906
Q0101	335763	transistor 2N 3904
Q0103	330264	transistor J 111 A
Q0104	335763	transistor 2N 3904

Ref. No.	Part no.	Description
Q0105	348421	transistor 2N 3906
Q0106	348422	transistor MPSA 42
Q0107	348423	transistor MPSA 92
Q0108	335763	transistor 2N 3904
Q0109	348421	transistor 2N 3906
Q0110	348422	transistor MPSA 42
Q0111	348423	transistor MPSA 92
Q0112	335763	transistor 2N 3904
Q0113	348421	transistor 2N 3906
Q0114	335763	transistor 2N 3904
Q0115	348421	transistor 2N 3906
00010	338869	transistor MJE 350
00010	338868	transistor MJE 340
Q0118	348409	transistor 2SC 4793
Q0119	348421	transistor 2N 3906
Q0120	335763	transistor 2N 3904
Q0121	335763	transistor 2N 3904
Q0122	348421	transistor 2N 3906
Q0123	351981	transistor MJL 3281 A
Q0124	351982	transistor MJL 1302 A
Q0125	331657	transistor MJ 15022
Q0126	331658	transistor MJ 15023
Q0127	331657	transistor MJ 15022
Q0128	331658	transistor MJ 15023
Q0129	331657	transistor MJ 15022
Q0130	331658	transistor MJ 15023
Q0131	331657	transistor MJ 15022
Q0132	331658	transistor MJ 15023
Q0133	331657	transistor MJ 15022
Q0134	331658	transistor MJ 15023
Q0135	348422	transistor MPSA 42
Q0136	348423	transistor MPSA 92
Q0137	348423	transistor MPSA 92
Q0138	348422	transistor MPSA 42
Q0139	307911	transistor BF 391
Q0140	307911	transistor BF 391
Q0141	348423	transistor MPSA 92
Q0142	348423	transistor MPSA 92
Q0143	348421	transistor 2N 3906
Q0144	348421	transistor 2N 3906
Q0145	335763	transistor 2N 3904
Q0146	306928	transistor BC 560 C
Q0300	348421	transistor 2N 3906
Q0301	335763	transistor 2N 3904
Q0303	330264	transistor J 111 A
Q0304	335763	transistor 2N 3904
Q0305	348421	transistor 2N 3906
Q0306	348422	transistor MPSA 42
Q0307	348423	transistor MPSA 92
Q0308	335763	transistor 2N 3904
Q0309	348421	transistor 2N 3906
Q0310	348422	transistor MPSA 42
Q0311	348423	transistor MPSA 92
Q0312	335763	transistor 2N 3904

Ref. No.	Part no.	Description
Q0313	348421	transistor 2N 3906
Q0314	335763	transistor 2N 3904
Q0315	348421	transistor 2N 3906
00010	338869	transistor MJE 350
00010	338868	transistor MJE 340
Q0318	348409	transistor 2SC 4793
Q0319	348421	transistor 2N 3906
Q0320	335763	transistor 2N 3904
Q0321	335763	transistor 2N 3904
Q0322	348421	transistor 2N 3906
Q0323	351981	transistor MJL 3281 A
Q0324	351982	transistor MJL 1302 A
Q0325	331657	transistor MJ 15022
Q0326	331658	transistor MJ 15023
Q0327	331657	transistor MJ 15022
Q0328	331658	transistor MJ 15023
Q0329	331657	transistor MJ 15022
Q0330	331658	transistor MJ 15023
Q0331	331657	transistor MJ 15022
Q0332	331658	transistor MJ 15023
Q0333	331657	transistor MJ 15022
Q0334	331658	transistor MJ 15023
Q0335	348422	transistor MPSA 42
Q0336	348423	transistor MPSA 92
Q0337	348423	transistor MPSA 92
Q0338	348422	transistor MPSA 42
Q0339	307911	transistor BF 391
Q0340	307911	transistor BF 391
Q0341	348423	transistor MPSA 92
Q0342	348423	transistor MPSA 92
Q0343	348421	transistor 2N 3906
Q0344	348421	transistor 2N 3906
Q0345	335763	transistor 2N 3904
Q0346	306928	transistor BC 560 C
Q0501	306928	transistor BC 560 C
Q0502	348422	transistor MPSA 42
Q0503	348422	transistor MPSA 42
Q0504	301184	transistor BC 550 B
Q0505	301184	transistor BC 550 B
Q0506	306928	transistor BC 560 C
Q0507	306928	transistor BC 560 C
R0037	348490	safety component NTC
R0065	348550	safety resistor 10 ohm
R0185	348456	resistor 2x0.22 ohm 5 watt
R0188	348456	resistor 2x0.22 ohm 5 watt
R0191	348456	resistor 2x0.22 ohm 5 watt
R0194	348456	resistor 2x0.22 ohm 5 watt
R0197	348456	resistor 2x0.22 ohm 5 watt
R0208	348593	safety component NTC
R0209	348593	safety component NTC
R0223	341713	resistor 4.70 ohm 4 watt
R0225	341713	resistor 4.70 ohm 4 watt
R0227	341713	resistor 4.70 ohm 4 watt
R0385	348456	resistor 2x0.22 ohm 5 watt

Ref. No.	Part no.	Description
R0388	348456	resistor 2x0.22 ohm 5 watt
R0391	348456	resistor 2x0.22 ohm 5 watt
R0394	348456	resistor 2x0.22 ohm 5 watt
R0397	348456	resistor 2x0.22 ohm 5 watt
R0408	348593	safety component NTC
R0409	348593	safety component NTC
R0423	341713	resistor 4.70 ohm 4 watt
R0425	341713	resistor 4.70 ohm 4 watt
R0427	341713	resistor 4.70 ohm 4 watt
S0001	344037	switch dpdt latching
S0002	338886	switch slide
S0500	344037	switch dpdt latching
VR100	348486	pot trim 47 kohm lin
VR101	348674	pot trim 220 ohm lin
VR300	348486	pot trim 47 kohm lin
VR301	348674	pot trim 220 ohm lin
VR501	343250	potentiometer 10kohm lin
VR502	343250	potentiometer 10kohm lin
	303576	fuse clip
	348855	fuse clip
	354306	connector male 16-pin
	348341	connector female 3-pin

MEMO