

# Electro-Voice®

## Service Manual

Interface: A™

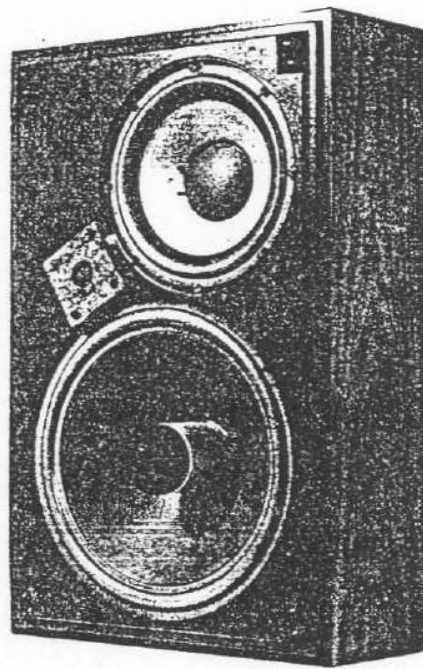
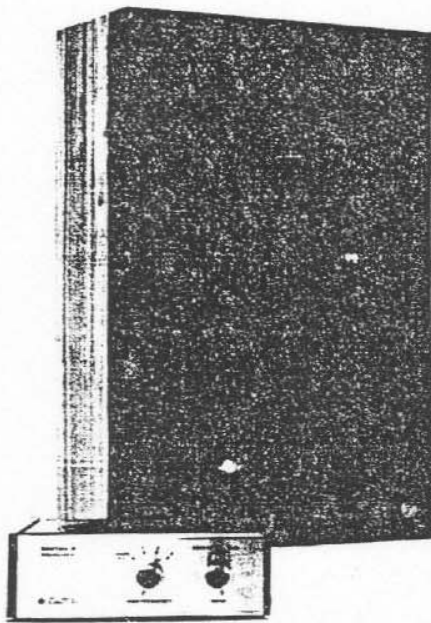

### Warranty

Interface:A is guaranteed against malfunction due to defects in workmanship and materials. If such malfunction occurs, Interface:A will be repaired or replaced (at our option) as follows:

Speaker systems will be repaired or replaced without charge for parts or labor for a period of five years from the date of original purchase.

Equalizer will be repaired or replaced without charge for parts for a period of three years from date of original

purchase and without charge for labor for a period of one year from date of original purchase.

All units must be delivered prepaid to the proper Electro-Voice service facility and will be returned prepaid. Warranty does not cover finish or appearance items or malfunction due to abuse or operation at other than specified conditions. Repair by other than Electro-Voice or its authorized service agencies will void this guarantee.

## Speaker System Testing

Remove the grille and retainer board for these tests.

### 1. RUB AND BUZZ AND OPERATIONAL CHECKS

Apply 4 volts to the system at 1000 Hz. and then sweep the system from 20 to 20,000 Hz. Make sure the system is free from buzzes, rattles, rubbing noises, etc. Verify that both the 8-inch woofer and front tweeter are operational by listening close to the individual components while sweeping. (Crossover frequency between these components is 1,500 Hz.) Verify the operation of the rear tweeter by listening close with the oscillator set between 8,000 and 10,000 Hz.

### 2. ENCLOSURE "TUNING" AND AIR LEAKS

When the system is operating properly, the excursion of the 8-inch woofer will drop near the system tuning frequency, normally between 30 and 34 Hz. Below the null frequency, the 8-inch excursion will increase again. While carefully adjusting the oscillator frequency, look for this reduction in cone motion on the 8-inch woofer.

Once the tuning frequency is found, leave the oscillator set at this frequency and increase the input voltage to 10 volts. Listen for any air leaks

from the various openings of the enclosure that can be heard at a distance of about 1 foot. Seal any such leaks found. (It is sometimes easier to find the exact location of a leak when listening through a small tube of 1/2 to 1 inch diameter and a foot or two long.)

### 3. CABINET APPEARANCE

Visually inspect the cabinet for scratches or unsightly details and repair where possible.

WHEN TESTING IS COMPLETED, RE-INSTALL THE RETAINER BOARD ON THE LOW FREQUENCY RADIATOR TO AVOID SHIPPING DAMAGE.

Re-pack the system neatly in the carton. Make sure a poly bag is used to protect the walnut finish and grille cloth.

ERRATUM: On page 1, under equalizer specifications, maximum boost is 6 dB at 35 Hz.

## Introduction

Interface:A represents a unique approach to the design of a quality speaker system. Owing to the special technology, and the system design, the following information and detailed instructions are required to properly service the speaker systems and equalizer.

This service manual provides detailed data to enable the professional technician to analyze and correct any problem that may be encountered. Service should not be performed by anyone who is not familiar with techniques involved in the repair of sophisticated speaker systems.

## Parts & Service

Parts for Interface:A may be obtained from the Electro-Voice Service Department in Buchanan, Michigan. Interface:A is sold in three separate cartons, two systems and equalizer. The speaker system or equalizer may be returned for factory service to the address shown at the bottom of this page. It is not necessary to return all three items if service is required for one item.

A full discussion of the technical aspects of Interface:A may be obtained by requesting an Interface:A brochure from the Advertising Department of Electro-Voice.

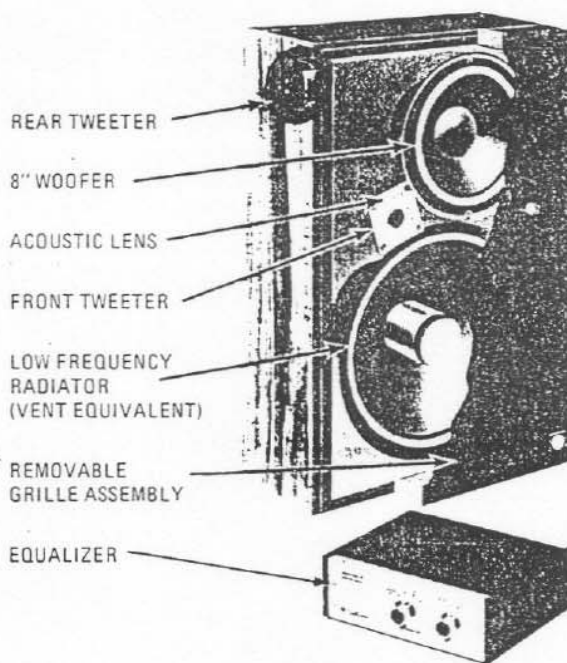

INTERFACE: A

## Specifications

### SPEAKER

Description:	Wide-band vented system of true bookshelf size.
Dimensions:	22" H x 14" W x 7 $\frac{3}{4}$ " D
Enclosure Volume:	1,350 cu. inches
Driver Complement:	12" Low frequency Radiator (vent equivalent) 8" Woofer 2 $\frac{1}{2}$ " Front Tweeter 2 $\frac{1}{2}$ " Rear Tweeter
Impedance:	8 ohms nominal
Minimum Power Recommended:	10 watts RMS (99 dB @ 3 ft.)
Maximum Rated Power:	25 watts continuous
Low Frequency Limit:	32 Hz
Efficiency:	.7%
Cabinet Finish:	Walnut Veneer
Weight:	27 lbs each enclosure

ELECTRO-VOICE, INC.  
Service Department  
600 Cecil Street.  
Buchanan, Michigan 49107

### EQUALIZER

Description:	Wide-band equalizer providing for low frequency equalization below 100 Hz and variable High Frequency equalization above 2 kHz.
Dimensions:	2 $\frac{3}{4}$ " H x 8" W x 7" D
Gain:	Unity
Equalization:	Maximum 6 dB @ 32 Hz. Maximum +3 dB at 10 kHz (Pos #1) -3 dB at 10 kHz (Pos #3)
Maximum Signal Input:	8V RMS, decreasing to 4V RMS @ 32 Hz
Noise Output:	20 Micro-volts (80 dB below 200 mV)
Total Harmonic Distortion:	.01%
Intermodulation Distortion:	.01%
Input Impedance:	100 k ohms
Output Impedance:	1.2 k ohms
Suggested Minimum Load Impedance:	10 k ohms
Controls:	Input Selector & Power/High Frequency
Power Requirements:	110-120 V, 50-60 Hz, 3 Watts
Weight:	2 lbs. 10 oz.

## Disassembly Illustration on Page 3

### IMPORTANT:

In order to perform most service procedures, the grille must be removed. If the speaker is to be rested upon its face, support should be provided to the ends of the speaker cabinet to prevent damage to the front-mounted components.

### SPEAKER GRILLE REMOVAL

The grille is quickly removed by pulling the grille free at each corner. To re-install, simply position in place, and apply pressure at the points where the VELCRO fasteners are located.

### FRONT TWEETER REMOVAL (Tweeter Part No. 78756)

1. Remove the four screws securing the acoustic lens assy (items 7 & 8) and front tweeter (5). Remove the square felt lens, being careful not to lose the four metal spacers (9). Carefully remove the foam square (8) which may be stuck to the cabinet. A razor blade may be required to remove the foam without tearing it.
2. Remove the tweeter, noting the location and color of the wires for proper phasing. When re-installing, seal the tweeter to the cabinet with liquid silicone or foam gasket if one is provided.
3. Re-install the spacers, foam and felt lenses and securing screws as shown in assembly detail.

### 8" WOOFER REPLACEMENT (Woofers Part No. 79370)

1. Remove the speaker securing screws. Pry speaker loose, and remove. Note color and location of speaker leads for proper phasing.
2. When re-installing, seal the new speaker to the cabinet with liquid silicone or other suitable gasket material. **IMPORTANT NOTE:** Any air leak in the cabinet will result in reduced bass response and excessive excursion. To check for air leaks, manually move (slowly) the low frequency radiator. The 8" woofer cone should move to equal the displacement caused by the movement of the radiator.

### LOW FREQUENCY RADIATOR TRANSPLANT (Part No. 87935)

The low frequency radiator or vent equivalent has no wiring, and therefore, is electrically not in the circuit. Under normal conditions the radiator will operate with no required service.

If it is required to replace the radiator, the following procedure will insure proper installation:

1. Remove the 8" woofer as previously outlined.
2. Using a sharp instrument, cut the flexible surround of the radiator. The edge of the surround glued to the cabinet may be left in place.
3. Lifting the cut cone, cut the spider at the rear of the radiator and remove the radiator assembly from the cabinet.
4. Clean the residual glue and spider material from the surface to where the new spider is to be glued.

5. Lay speaker cabinet on its back. Evenly apply adhesive (surround adhesive No. 69X2042LV, or equivalent from General Adhesive Co.) to the two surfaces where the new radiator cone and spider are to be glued to the cabinet.
6. Install the new radiator assembly. The wood retainer should be secured to the replacement radiator assembly to assure proper positioning of the assembly during installation. Work the speaker in a circular motion to insure proper contact with the adhesive. To insure proper positioning and glueing of the spider, reach through the 8" bass speaker opening and press the spider firmly into the adhesive. Also press around the edge of the cone surround to assure even glue distribution and airtight sealing. Allow speaker to remain on back until glue is dried. **Note:** use only recommended glue or equivalent. Some adhesive may cause surround to "curl", resulting in air leaks. When adhesive is dry, re-install the 8" woofer. **THE SEAL AROUND THE OUTER EDGE OF THE CONE MUST BE AIRTIGHT. ANY AIR LEAK WILL RESULT IN NOISES AND REDUCED BASS RESPONSE.**

### LOOSE WOOD PLUG IN RADIATOR

The wood plug in the radiator tube may loosen. To secure the plug to the tube, and provide an airtight seal, clean the inside surface of the tube and apply thickened epoxy all around the inside edge of the tube. Insert and rotate the wood plug. Allow epoxy to cure before operating speaker.

The wood plug is used primarily to secure the radiator during shipment. If the Interface:A is to be re-shipped, it will be necessary to properly position the screw holes in the wood plug to allow installation of the shipping board.

### REAR TWEETER REMOVAL (Tweeter Part No. 78756)

1. Apply MEK (Methyl Ethyl Keytone) or other suitable solvent to the gap between the tweeter grille and the cabinet. Allow the grille adhesive to soften, then remove the grille from the cabinet. Use care to avoid damage to grille (Grille Part No. 79394).
2. Remove the two screws securing the tweeter. Remove the tweeter, noting the location and color of the wires for proper phasing. When re-installing, seal the tweeter to the cabinet with liquid silicone or foam gasket if one is provided.
3. Cement tweeter grille (Part No. 79394) in place using rubber cement. Leave cabinet face down until glue is dry.

### SERVICING THE CROSSOVER (Part No. 87933)

To gain access to the crossover, remove the 8" woofer as outlined previously. If crossover assembly is to be removed, disconnect all speaker wiring, then pry the crossover board loose from the inside (it will be necessary to break the glue bond). For further service data refer to the schematic diagram and parts location diagram.

If the crossover has been removed, it will be necessary to provide an airtight seal. Thickened epoxy is recommended. Any air leaks will result in noises and reduced bass response. Be sure the crossover is properly positioned before applying the epoxy adhesive.

# Speaker Assembly Detail

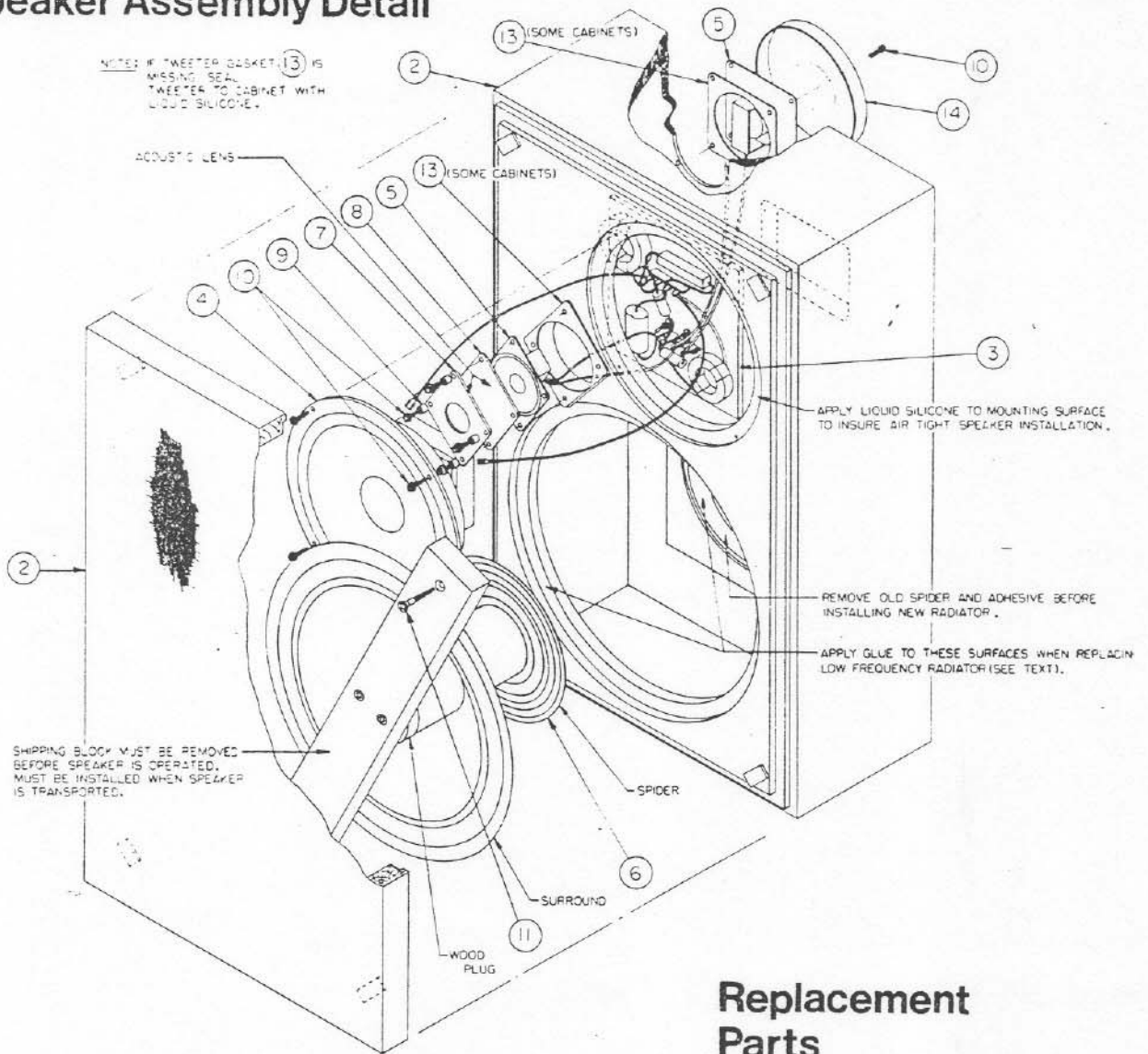

## Replacement Parts

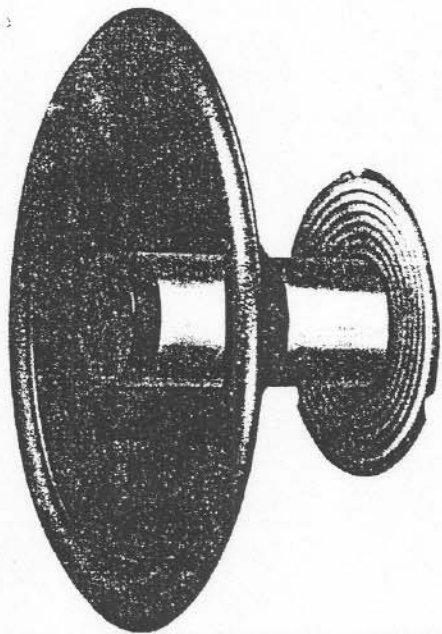

LOW FREQUENCY RADIATOR (VENT EQUIVALENT)

*Plastic*  
70171UA  
2P.s

Ref No.	Part No.	Description
1	48471	Nameplate (not shown)
2	87932	Enclosure, Cabinet and Grille Assy
2-A	79836	Enclosure, Cabinet only
2-B	79837	Enclosure, Grille only
3	87933	Crossover Assy
4	79370	8" Woofer
5	78756	Tweeter, Front & Rear
6	87935	Low Frequency radiator
7	79372	Felt Lens
8	79373	Foam Lens
9	2081-AD	Lens Spacer
10	62849	Screw #8 x 1
11	62876-AE	Screw #10 x 1 1/4
12	20793-AP	Knurled nut, Speaker terminal (not shown)
13	38610	Tweeter Gasket
14	79394	Rear Tweeter Grille
15	77683	Cabinet cushion (not shown)
16	79494	Fiberglass batting (not shown)
17	96047	Carton (not shown)
18	69061	Wood Retainer, shipping block
19	69063	Wood plug, for low frequency sub-assembly

# Interface: A Equalizer PC Board Assembly

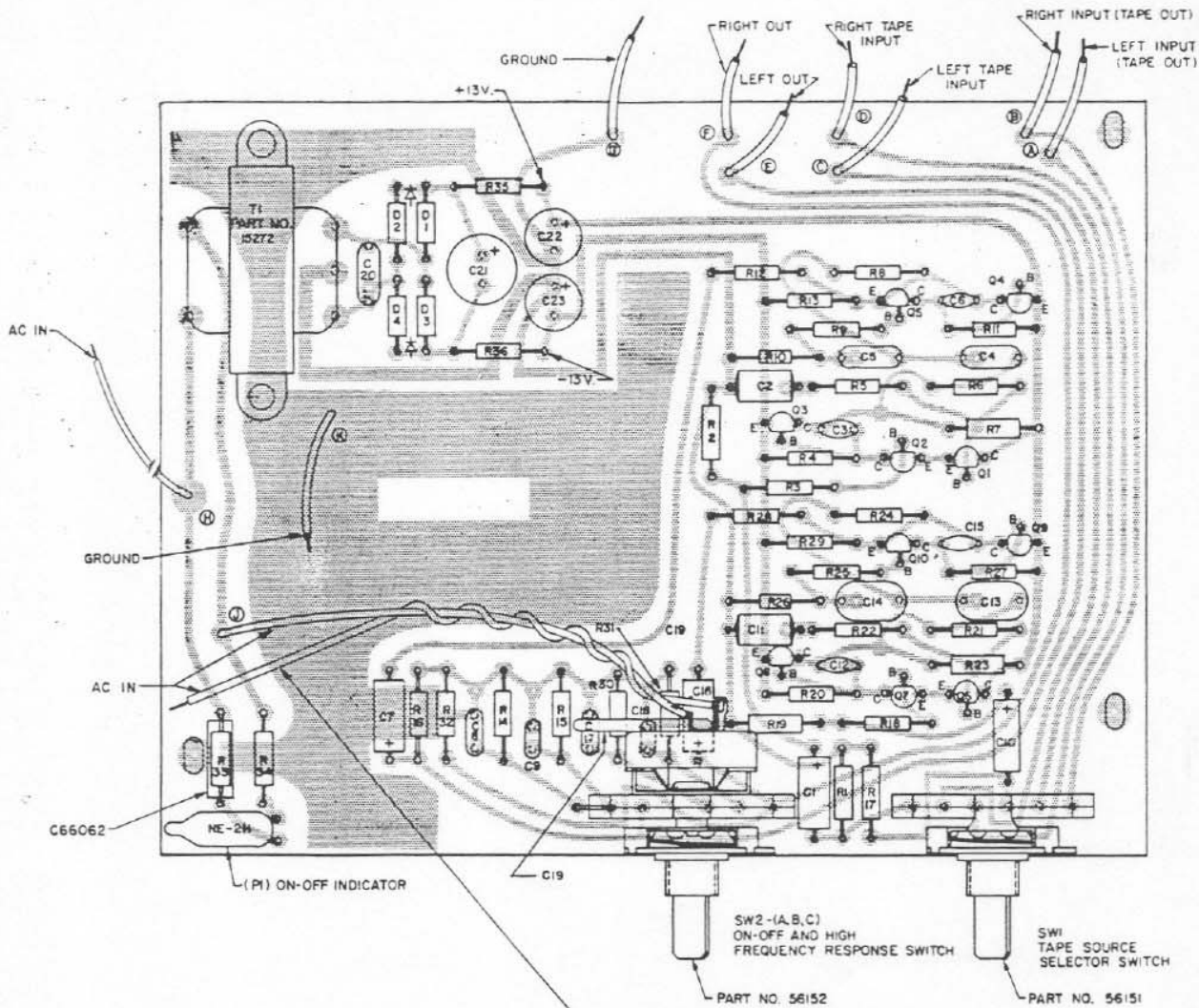

## Electrical Parts for Equalizer

Ref No.	Part No.	Description
T1	15272	PWR Transformer
<b>TRANSISTORS</b>		
Q1, Q6	43180	Transistor, NPN
Q2, Q7	43212	Transistor, PNP
Q3, Q8	43045	Transistor, NPN
Q5, Q10	43180	Transistor, NPN
Q4, Q9	43162	Transistor, PNP
<b>MISCELLANEOUS</b>		
D1, D2	A43067	Diode, Power SPPY
D3, D4	A43067	Diode, Power SPPY
E1	4488	AC Power Recept.
P1	43193	Neon Indicator
	17137	Phono Connector

Ref No.	Part No.	Description
<b>MISCELLANEOUS cont'd</b>		
	17138	Insulator, Phono Conn.
	16511	AC Line Cord
SW1	56151	Selector Switch
SW2	56152	On/Off & Function Switch
<b>CAPACITORS</b>		
C1, C10	E42365	Lytic, 5 MF @ 15V
C2, C11	42635	.0012 MF 5%
C3, C12	42547	27 pF 10% Ceramic
C4, C5	42620	.1 MF 5%
C6, C15	42547	27 pF 10% Ceramic
C7, C16	E42365	Lytic, 5 MF @ 15 V
C8, C17	42637	.022 MF 5%
C9, C18	42636	.012 MF 5%
C13, C14	42620	.1 MF 5%

NOTE: AC INPUT LEADS TWISTED TO MINIMIZE HUM

# Equalizer Schematic Diagram

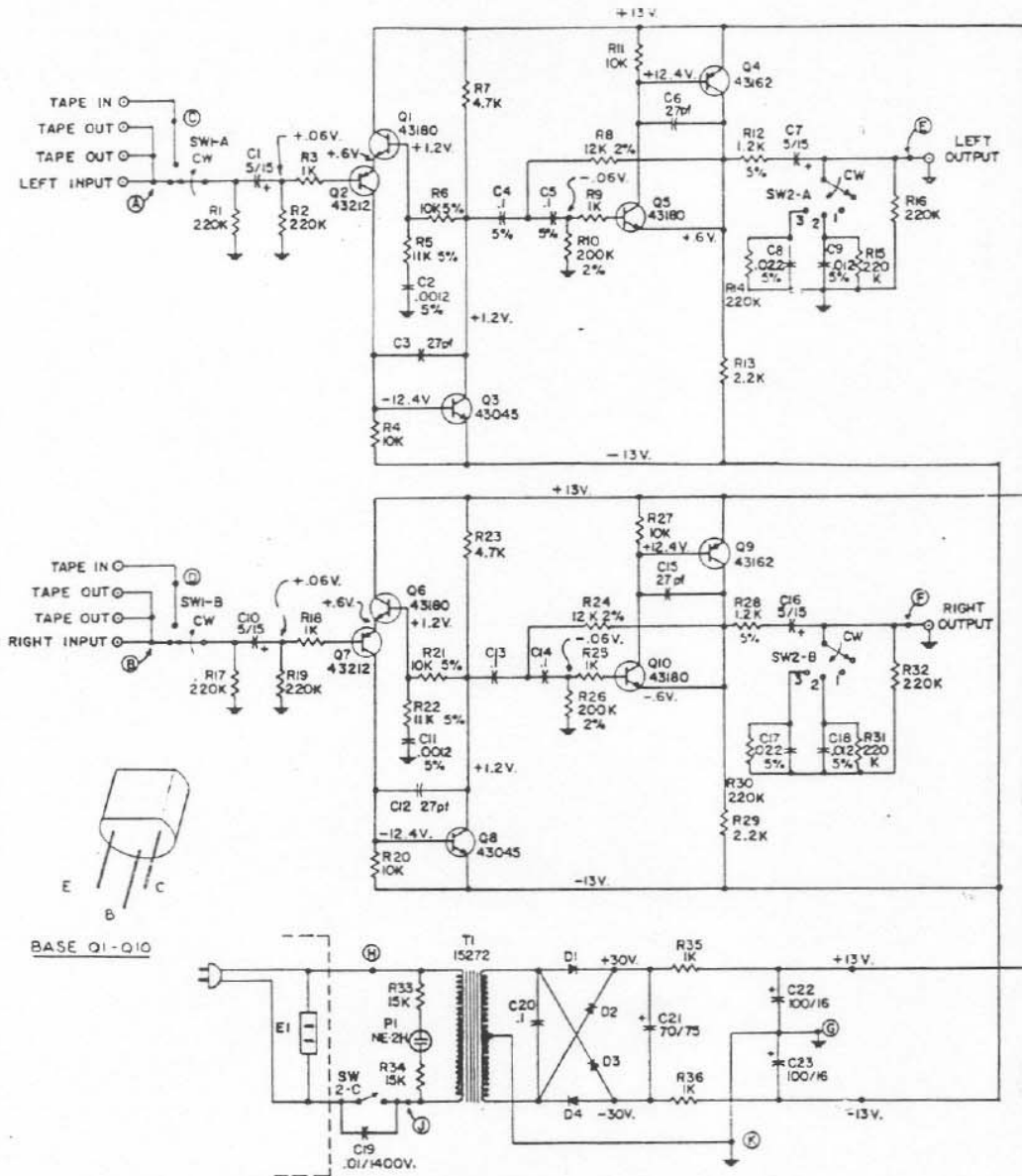

## Electrical Parts For Equalizer Cont'd

Ref No.	Part No.	Description
<b>CAPACITORS cont'd</b>		
C19	42482	.01 MF 1400 V
C20	42363	.1 MF 20%
C21	42648	Lytic, 70 MF @ 75 V
C22, C23	42619	Lytic, 100 MF @ 16V
<b>RESISTORS (Unique)</b>		
R5, R22	E46646	11 K 5% ½ Watt
R6, R21	E46643	10 K 5% ½ Watt
R8, R24	E46644	12K 2% ½ Watt
R10, R26	E46645	200 K 2% ½ Watt
<b>P.C. BOARD ASSY COMPLETE, PART No. 87941 (For Reference Only)</b>		

## Mechanical Parts For Equalizer

Ref No.	Part No.	Description
1	79283	Knob, Selector
2	20827	Nut 3/8 32
3	87942	Front Panel Assy.
4		Not supplied
5		Not supplied
6		Not supplied
7		Not supplied
8		Refer to Electrical parts
9	79246	End Panel
10	79249	Inlay-end Panel
11-15		Not supplied
16	17137	Phono Connector
17	17138	Insulator, Phono Conn.

# Equalizer Assembly Detail

(Parts Listed on Previous Page)

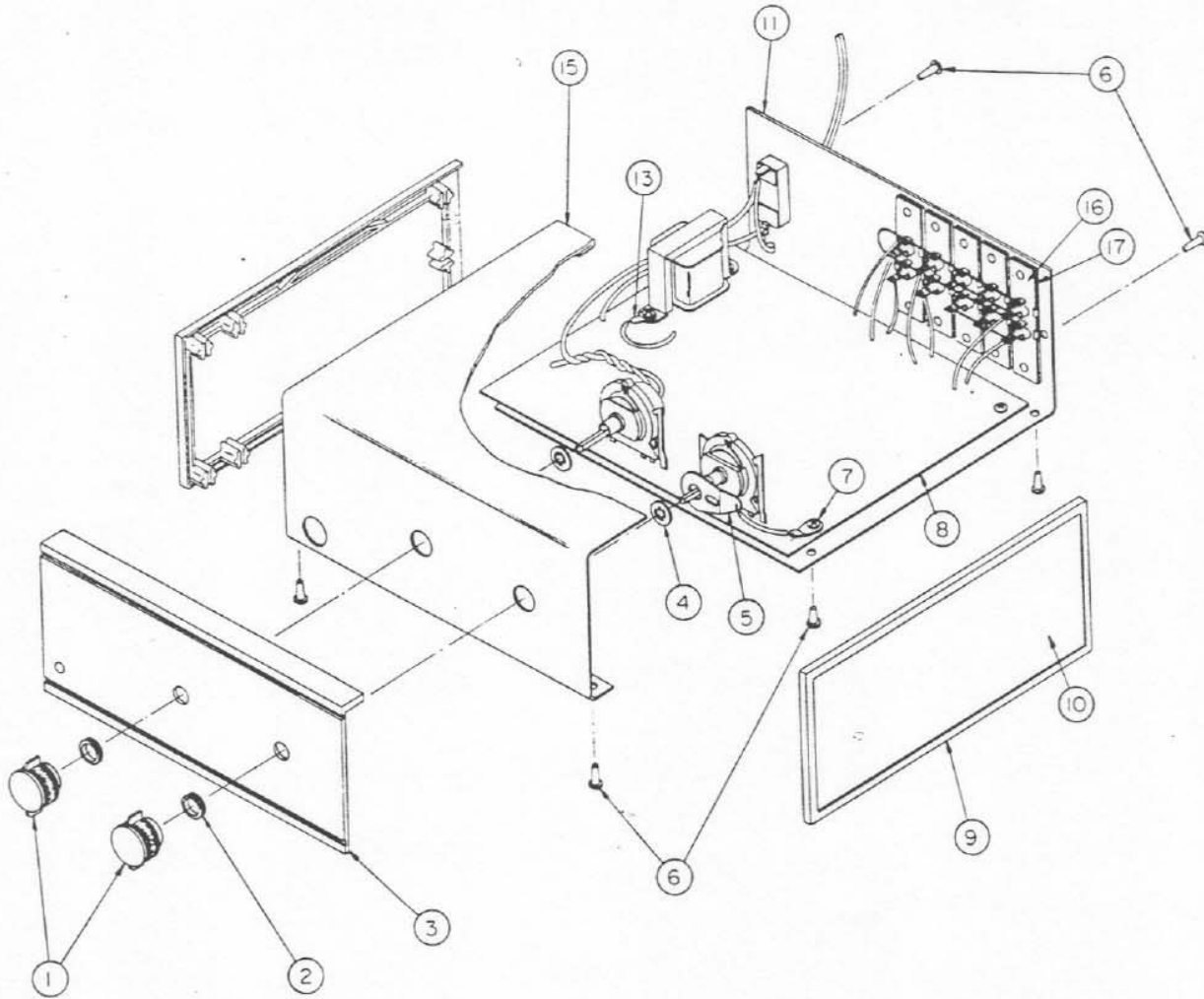

# Speaker Wiring Diagram

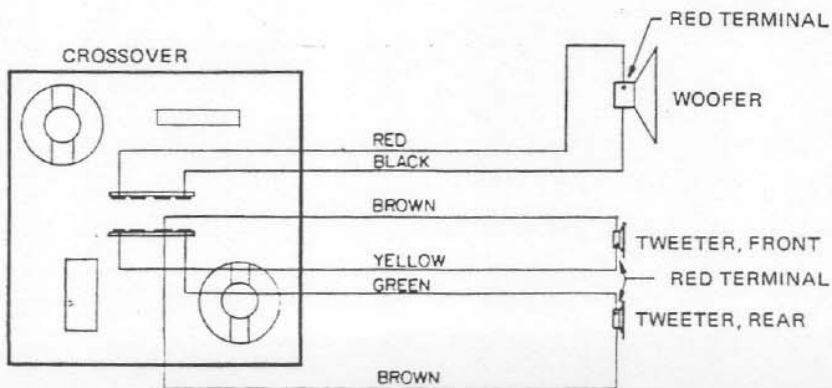



# Equalizer - Specification Tests

## OVERLOAD

The equalizer may be tested for overload distortion as follows:

1. Apply a 35 Hz, 4 Volt RMS signal to the inputs.
2. The output waveforms should be undistorted and show no clipping.

## FREQUENCY RESPONSE

Apply a 1 Volt RMS signal to the inputs. The frequency response of the left and right channels should fall within the specifications given in the chart.

## TOTAL HARMONIC DISTORTION

Total Harmonic distortion may be measured as follows:

1. Switch the selector switch to position #1.
2. Apply a 2 Volt RMS signal to the inputs.
3. Harmonic distortion in the output of the equalizer should measure less than .01% at any frequency between 10 Hz and 20 kHz.

## EQUALIZER NOISE OUTPUT

The noise level from the equalizer may be measured as follows:

1. Terminate the inputs with 560 ohm resistors.
2. Measure the noise present at the left and right channel outputs. The noise output should measure less than 20 microvolts. The AC line cord may be reversed if necessary to obtain minimum noise output.

NOTE: 20 microvolts = 80 dB below 200 millivolts

# Equalizer Response

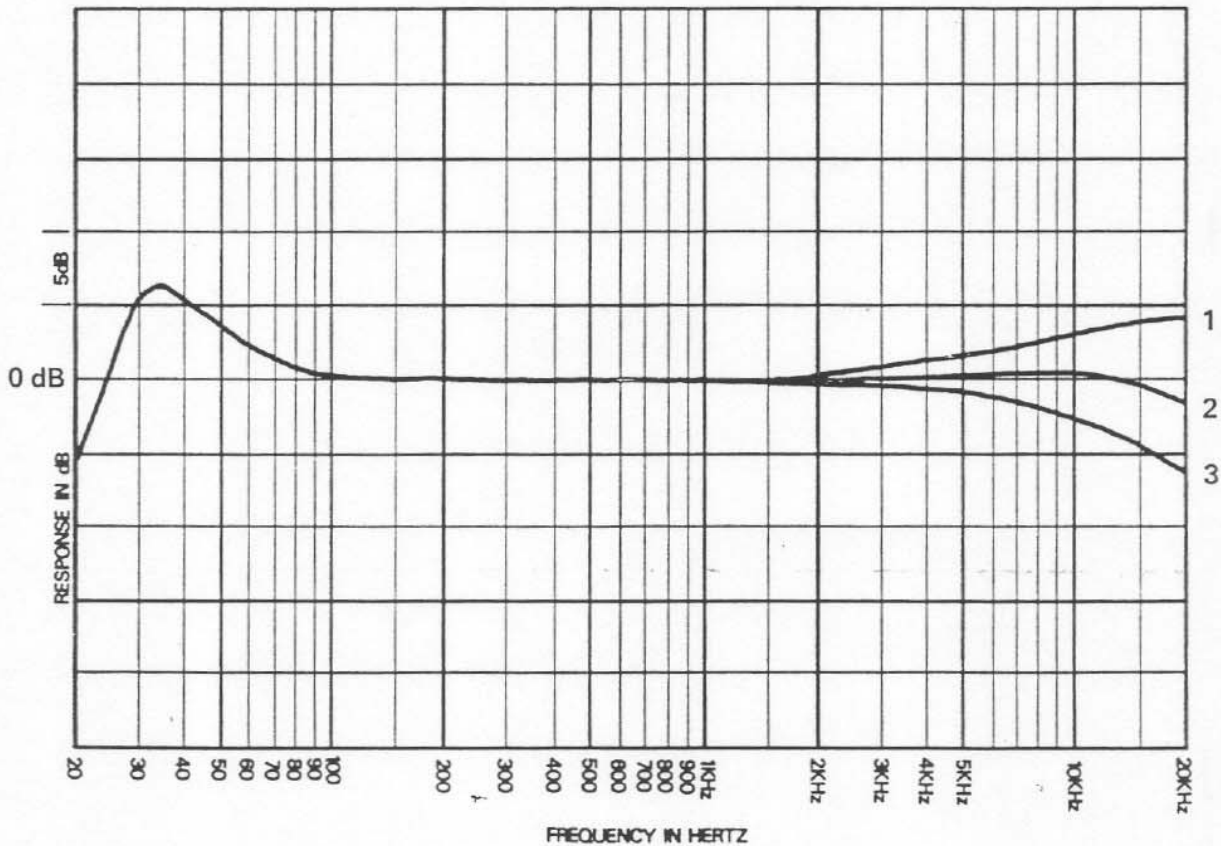

# Speaker Schematic Diagram

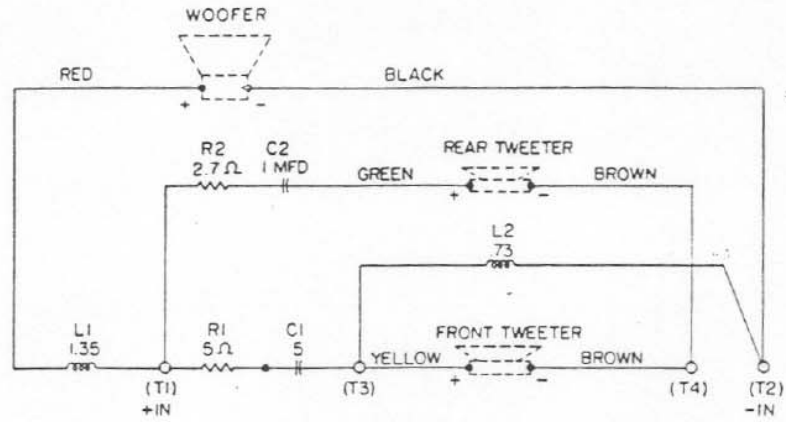

## Crossover Replacement Parts

Item	Part No.	Description
1	87933	Crossover, Complete
2	35095	Inductor L1, 1.35 mH
3	42524	Capacitor C1, 5 MF
4	46610	Resistor R1, 5 ohm 5 Watt
5	27348	Terminal Strip
6	3840	#8 Lockwasher
9	3584	Inductor L2, .73 mH
11	3980	#8 Flat washer
15	B606216	Screw, #8-32 x 1"
16	20792	Nut, #8-32
17	20793	Nut, Knurled
18	46133	Resistor R2, 2.7 ohm 2 Watt
19	42605	Capacitor C2, 1 MF

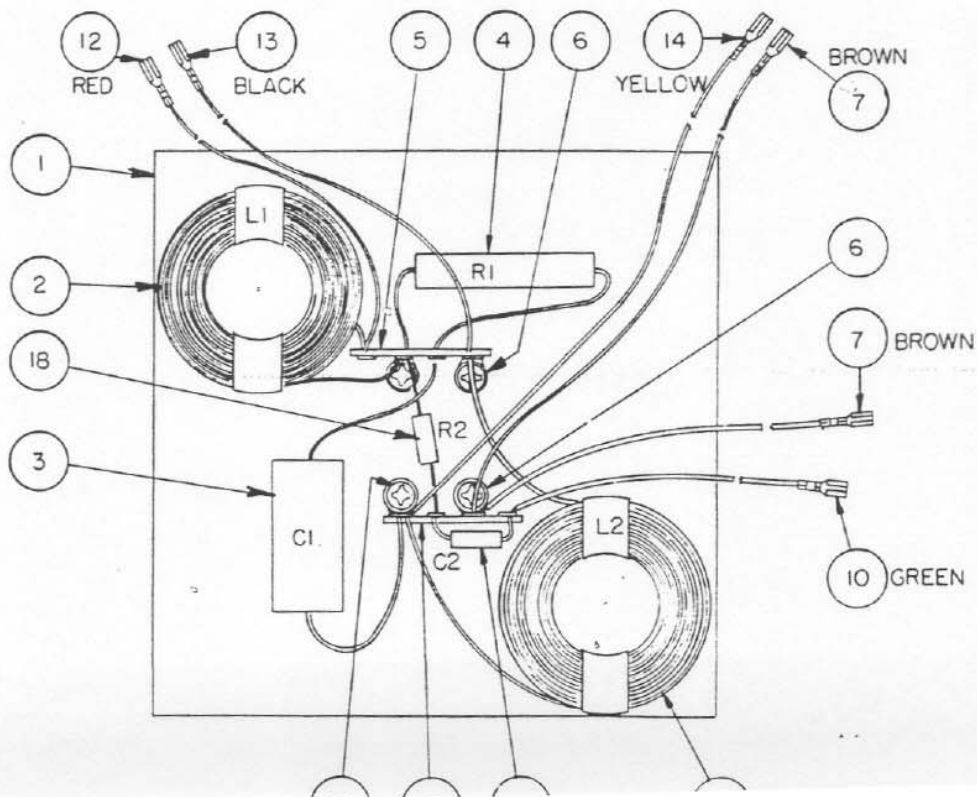

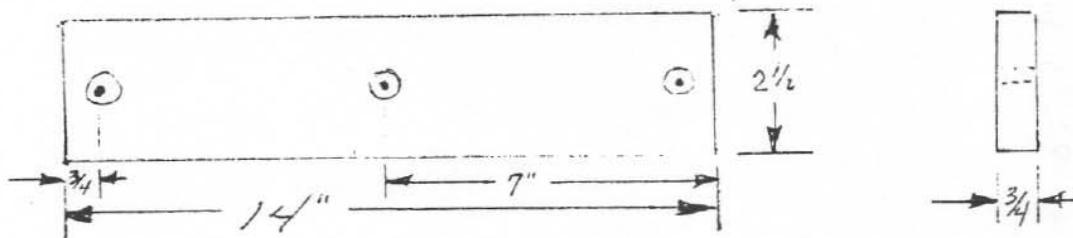

3 HOLES  $\frac{1}{4}$ " DIA THRU  
 $\frac{3}{8}$ " COUNTERSINK

PAINT FLAT BLACK

PART # 69061

Instructions for replacing passive radiators:

Do not remove support board. We recommend installing passive radiators before installing woofers.

- (1) Clean surfaces where spider and cone will be glued to cabinet.
- (2) Put a large bead of rubber cement (EV Part#9749) in area for spider, and smaller bead around area where cone will be attached.
- (3) Place passive radiator into cabinet, being certain to seat spider properly, and carefully press cone surround into place.

Surround will wrinkle, but can be pressed smooth.