



**P 1201**  
**P 1202**

MODULAR PRECISION SERIES

**Technical Specifications: X1201 / P1201**

Amplifier at rated conditions, 8Ω output load, unless otherwise specified.

	<b>X1201 / P1201</b>		
<b>Load Impedance</b>	8 Ω	4 Ω	2 Ω
<b>Maximum Midband Output Power</b> THD = 1%, 1kHz	750 W	1200 W	1600 W
<b>Rated Output Power</b> THD < 0.2%, 20Hz ... 20kHz	500 W	1000 W	-----
<b>Max. Single Channel Output Power</b> Dynamic-Headroom, IHF-A	850 W	1450 W	1700 W
<b>Maximum RMS Voltage Swing</b> THD = 1%, 1kHz		86 V	
<b>Voltage Gain</b> at 1kHz		33 dB	
<b>Slew Rate</b> at 1kHz		40 V/μs	
<b>Power Consumption</b> at 1/8 maximum output power @ 4Ω		870 W	
<b>Input Sensitivity</b> at rated output power @ 4Ω, 1kHz		1.4 V	
<b>THD</b> at rated output power, MBW = 80kHz, 1kHz		< 0.05 %	
<b>IMD-SMPTE</b> 60Hz, 7kHz		< 0.08 %	
<b>DIM30</b> 3.15kHz, 15kHz		< 0.03 %	
<b>Frequency Response</b> -1dB, ref. 1kHz		13 Hz ... 45 kHz	
<b>Power Bandwidth</b> THD = 1%, ref. 1kHz, half power @ 4Ω		10 Hz ... 50 kHz	
<b>Input Impedance</b> 20Hz ... 20kHz, balanced		20 kΩ	
<b>Damping Factor</b> at 100Hz / 1kHz, 8Ω		> 300 / > 200	
<b>Signal to Noise Ratio</b> A-weighted, non internal summing mode		106 dB	
<b>Power Requirements</b>	240V, 230V, 120V, 100 V, 50Hz ... 60Hz, factory configured		
<b>Protection</b>	Audio limiters, High temperature, DC, HF, Back-EMF, Peak current limiters, Inrush current limiters, Turn-on delay		
<b>Cooling</b>	Front-to-rear, 3-stage-fans		
<b>Safety Class</b>	I		
<b>Dimensions</b> (W x H x D), mm	483 x 132.5 x 426		
<b>Weight</b>	17 kg		
<b>Optional</b>			
Input transformer		NRS 90208 (121 641)	
Rear-rackmount 15,5"		NRS 90235 (112 733)	
Rear-rackmount 18"		NRS 90223 (112 701)	

The measured data apply to the following appliances:

Unit Model	Unit Number	Mains Voltage	Mains Frequency
X1201	112 736	230V	50 - 60 Hz
X1201		240V	50 - 60 Hz
X1201		100V	50 - 60 Hz
X1201		120V	50 - 60 Hz
P1201	170 149	230V	50 - 60 Hz
P1201	170 148	120V	50 - 60 Hz
P1201	170 148	100V	50 - 60 Hz

#### MEASURED DATA: X1201 / P1201

Printed boards name and corresponding EDP numbers:

Printed boards EDP numbers			
100V	120V	230V	240V
81344	81344	81344	81344
84199	84199	84194	

Printed board parts 84194 / 84199	Index
Amplifier - PCB	84194/1 / 84199/1
Bus - PCB	84194/2 / 84199/2
Main - PCB	84194/3 / 84199/3
LED - PCB	84194/4 / 84199/4

Testing Conditions – unless differently stated:

- Measuring tolerance:  $\Delta X = \pm 1.5\text{dB}$
- Measuring frequency:  $f = 1\text{kHz}$
- Stated level values referred to:  $U = 775\text{mV (0dBu)}$
- XLR – socket pin-assignment:
  - PIN 1 = GROUND/SHIELD
  - PIN 2 = + INPUT
  - PIN 3 = - INPUT
- Source impedance for signal-feed via XLR – socket:  $R(Q) = 50\Omega$
- The printed board assembly 84194 / 84199 offers **service connectors**.

84194/2 / 84199/2 CNS1X		84194/2 / 84199/2 CNS2X		84194/1 / 84199/1 CN10 / CN11	
PIN	Assignment	PIN	Assignment	PIN	Assignment
1	-Vcc	1	LIM Switch	CN10	
2	BIAS +HOT	2	-15V	1	FLOAT. Voltage
3	BIAS -HOT	3	SYMMETRY	2	GND A
4	FAN Voltage	4	+15V	3	GND A
5	+Vcc	5	GND A	CN11	
6	BIAS +COLD	6	Speaker A	1	LIM Switch
7	BIAS -COLD	7	Relay/Protect	2	-15V
8	TEMP Heat sink	8	n.c.	3	-15V

**1. Operating Voltage:** U(B) = 230V 50Hz ... 60Hz / U(B) = 120V 50Hz ... 60Hz

**2. Operating Voltage Deviation Range:** -30% .... +10%

### 3. Power Consumption

- Driven with sine signal  $f = 1\text{kHz}$

	X1201 / P1201	Output Power
Idling Power Consumption	50 - 70 W	
Maximum Power Consumption (RL=4Ω)	1870 W	1200 W
Nominal Power Consumption (RL=4Ω)	1730 W	1000 W
Standard Power Consumption (RL=4Ω)	590 W	100 W
Power Consumption at 1/8 of the Max. Output Power	720 W	156 W
Power Consumption at 1/8 of the Max. Output Power at 10 % Mains Overvoltage	870 W	180 W

### 4. Settings/Adjustments

#### 4.1. IDLING CURRENT ADJUSTMENT

Connect a DC-voltmeter to the BIAS measuring points (on the printed board assembly 84194/2 / 84199/2, see service connectors) and adjust the idling current via the trimmers VR101 / VR301 (on the printed board assembly 84194/1 /84199/1). Adjustment has to be performed for HOT / COLD  $U(\text{DC}) = 7.5\text{mV}$  and at normal room temperature. If the power amplifier has previously been operated, it has to be given several hours of time for regaining normal temperature.

#### 4.2. FLOATING - SYMMETRY

Checking and setting the floating voltage symmetry has to be performed immediately after adjusting the idling current.

Operate the power amplifier in idling condition. Measuring between the measuring points CNS1X.1 / CNS2X.5 and CNS1X.5 / CNS2X.5 with a DC-voltmeter, set the floating voltage symmetrical to GROUND via VR1 on the printed board assembly 84194/1 (84199/1).

The absolute voltage value is not critical but the symmetry of the  $\pm$  floating voltage over GROUND.

Checking the set floating voltage is possibly by use of a DC-voltmeter and measuring between on the service connector between CNS2X.3 and CNS2X.5 on the printed board assembly 84194/2 (84199/2) as well as on the pin terminal between CN10.1 and CN10.2/3 on the printed board assembly 84194/1 (84199/1).

The measured DC voltage value should be 0 volts.

#### 4.3. VCA - OFFSET

Rhythmically open and short-circuit the pin contacts CNS2X.1 and CNS2X.2 on the printed board assembly 84194/2 (84199/2). Use VR100 to adjust the power amplifier output to their minimum offset value (with oscilloscope to minimal peak value or to the audible minimum volume of the interfering pulse).

### 5. Function Test

#### 5.1. OUTPUT – Offset Voltage

DC-measurement at the loudspeaker outputs with  $U(\text{DC}) \leq \pm 10\text{mV}$ .

#### 5.2. LIMITER

##### 5.2.1. Attenuation Test

Power amplifier driven with a 1 kHz signal up to  $U(\text{A}) = 69\text{V}$  (without load). Increase the input voltage by 10dB. The LIMITER LED lights and the output voltage ascends by approximately 2dB to approximately 85 V while slightly clipping. The distortion rate of the limited signal is at THD = 1.0 ... 1.5%. Further increasing the input signal up to a value of +21dBu should not result in remarkably higher clipping.

##### 5.2.2. Attack and Release Times

Test has to be performed without load resistors connected.

1.) Drive the power amplifier with a burst signal ( $f = 1\text{kHz}$ , 10 cycles, rate:  $\approx 0.5\text{sec.}$ ) and  $U(\text{E}) = +16\text{dBu}$  at the input.

2.) Monitor the output signal via oscilloscope. After 3 to 4 signal periods, the limiter has controlled the high distortion level down to a minor residual distortion (THD = 1% .... 1.5%).

Attack time: 3-4 ms      Release time: 30-40 ms

### 5.3 POWER-ON DELAY

Make sure that the signal is present at the power amplifier input. Switch the power amplifier via the Power-ON switch on. Approximately 2 seconds after switching the power on, the signal will be present at the output.

### 5.4 FAN CONTROL

Upon switching the power amplifier's power on, the fans will run for approximately 2 seconds and stop when the power amplifier has regained "normal" temperature. In idling condition (Power-ON, no signal present) the fans are switched between SLOW and OFF mode, depending on the heat sink's temperature.

Removing the connector CN5 lets the fans run in FAST mode.

The fan voltage is measured between pin CNS2X.4 and pin CNS1X.4:      SLOW ca. 17.5 V      FAST ca. 29.0 V

### 5.5. SOAR-PROTECTION TEST

Drive the power amplifier up to 69 V in 4 $\Omega$ . Parallel-connect a 1  $\Omega$  resistor. The protection circuit reacts and continuously tries to re-start! The protect-LED lights. Repeat the test with a 2  $\Omega$  resistor. The power amplifier should not switch off.

**Caution:** If the SOAR-protection does not react in case of mains undervoltage, repeat the test with parallel-connecting a 0.5 $\Omega$  resistor instead of a 1 $\Omega$ .

### 5.6. SHORT-CIRCUIT CURRENT-LIMITING TEST

- drive each channel with a burst signal ( $f = 1\text{kHz}$ , 1-3 cycles, rate  $\approx 1$  sec.), with  $U(E) = 0\text{dB}$
- connect a 1 $\Omega$  load resistor
- the short-circuit current-limiter limits the output voltage at the load resistor symmetrically (monitor via oscilloscope) to a peak voltage value of 40 V (approximately 40 A maximum Peak Output Current).

### 5.7. DC-VOLTAGE PROTECTION TEST

- feed a test signal ( $f = 5 - 7$  Hz ) to the power amplifier without load resistor connected.
- starting at an input voltage of approximately 5 V<sub>eff</sub>, the protection circuit reacts and continuously tries to re-start!  
The protect-LED blinks in the same frequency.
- repeat the test with  $f = 14\text{Hz}$ . The power amplifier should not switch off.

### 5.8. HF-PROTECTION TEST

**Caution:** Perform tests without load resistor connected to the power amplifier only.

Feed a +20dBu sine burst signal  $f = 100\text{kHz}$  (40ms ON, 960ms OFF) to the power amplifier input.

The protection circuit has to react. The power amplifier continuously tries to re-start.

The PROTECT-LED blinks in the same frequency.

Repeat the test with  $f = 50\text{kHz}$ . The power amplifier should not switch off.

### 5.9. INDICATOR TEST

Feed a 1kHz sine signal while slowly increasing it.

At approximately -26dBu the SIGNAL-LED starts lighting and at approximately +8dBu the LIMIT-LED lights.

## 6. Level

### 6.1. VOLTAGE AMPLIFICATION

Unit	Input	U(E)	Measuring point	U(A)	U(A)	Gain	Load Resistor	Test frequency
X1201/ P1201	CH. A or B	+5.8dBu	OUTPUT	+39dBu	69.2V	33.2		1kHz
X1201/ P1201	CH. A + B	-0.2dBu	OUTPUT	+39dBu	69.2V	39.2		1kHz

6.2. MAXIMUM INPUT LEVEL:  $U(E) = +21\text{dBu}$

### 7. GROUND LIFT-switch

The circuit ground (at the input or output connector) is measured against the enclosure ground (contact on the ground-screw on the rear of the appliance or ground contact on the mains plug).

Switch set to GROUNDED :  $R = 0\Omega$

UNGROUNDED :  $R = 5\Omega$

### 8. Amplitude – Non-Linearity

- measured with a  $8\Omega$  load resistor connected

- MBW = 80kHz

Test	At nominal output power	Remarks
THD+N ( f = 1kHz )	<0.05%	
IMD-SMPTE	<0.08%	60Hz, 7kHz
DIM 30	<0.03%	3.15kHz, 15kHz

### 9. Frequency Response

Linear Frequency Response (mind border frequencies)

	Lower border frequency	Upper border frequency
-3dB	$f_u < 10\text{Hz}$	$f_o = 85\text{kHz}$
-1dB	$f_u = 13\text{Hz}$	$f_o = 45\text{kHz}$

### 10. Noise Interference

-  $U(F)$  = extraneous voltage non-weighted with  $B = 22\text{ Hz} \dots 22\text{ kHz}$ , effective value (IEC 268-1)

-  $U(G)$  = noise voltage, frequency-weighting filter according to CCIR-468-3, quasi peak-weighted (IEC 268-1)

-  $U(A)$  = interference voltage A-weighted, dB(A), effective value (IEC 268-1)

- S/N ratio ref. to max. output voltage into 4 ohms = 55.1 V (+37 dBu) and interference voltage A-weighted

Power Amp	Output	U(F) dBu	U(G) dBu	U(A) dBu	GAIN dB	IN(A) dBu	S/N-R. dB	Remarks
Input Channel A & B operated. (as shipped)								
X1201 / P1201	SPEAKER OUT	- 63	- 51	- 65	33	- 98	> 104	INPUT A&B $R(Q) = 50\Omega$
Only channel A operated. Remove the resistors R291 / R292 off the printed board assembly 84194/2.								
X1201 / P1201	SPEAKER OUT	- 65	- 54	- 67	33	- 100	> 106	INPUT A $R(Q) = 50\Omega$

### 11. Heat Sink Temperature

DC-voltages measured between CNS1X.8 and CNS2X.5 (GNDA)

Heat sink temperature	25°C	40°C	60°C	80°C	100°C	120°C	130°C
	1.5 V	3.0 V	6.0 V	9.0 V	12.0 V	13.0 V	13.8 V

The switch-off point is at approx. 130 °C. The power amplifier enters Protect-Mode.

### 12. SLOT-Specification

The power amplifier X1201 (P1201) is capable of providing a maximum current of ±300mA for individual modules with ± 15V operating voltage.

- measured at 10 % mains undervoltage.

	Power consumption:
Xi-11 / Xi-21 – Input modules	Approx. 18 mA
V – Front modules	Approx. 70 mA
I-1 Input module	Approx. 18 mA
MRx-Front modules	Approx. 70 mA

### 13. Dimensions and Weight

Power amplifier	Weight	Dimensions in mm
X1201 / P1201	17kg	483 x 132.5 x 385.5

### 14. Input Connector Pin-Assignment - CN7 and Module Slot Connectors - CNSLA

CN7		CNSLA		CNSLA	
PIN	Assignment	PIN	Assignment	PIN	Assignment
1	-15V	1a/1b	n.c.	9a	KA1 (Module ID)
2	GNDA	2a/2b	n.c.	9b	KA2 (Module ID)
3	Sensout A	3a/3b	n.c.	10a/10b	+15V
4	Return A	4a/4b	n.c.	11a/11b	AMPA2 (alt. Output 1in2)
5	Sensin A	5a	KA4 (Module ID)	12a/12b	LIMINA (Limiter Input)
6	Signal A	5b	KA5 (Module ID)	13a/13b	BUSREFA
7	GNDA	6a/6b	-15V	14a/14b	SIGNALA1 (Signal Out)
8	GNDA	7a	GNDA	15a/15b	SWA1 (Select)
9	Signal B	7b	KA3 (Module ID)	16a/16b	SIGNAL M (Signal In)
10	Sensin B	8a/8b	GNDA		
11	Return B				
12	Sensout B				
13	GNDA				
14	+15V				

### 15. Remote Control Connector Pin-Assignment CNRC / CNRC5V

PIN	CNRC Assignment	PIN	CNRC Assignment	PIN	CNRC5V Assignment
1	AMPA2	18	n.c.	1	GND-D
2	+5V	19	HTSNKTMP	2	GND-D
3	COLDCUR+	20	n.c.	3	POWER-ON
4	+5V	21	HOTCUR- (68Ω/⊥)	4	GND-D
5	COLDCUR-	22	n.c.	5	GND-D
6	KA1	23	HOTCUR+ (68Ω/⊥)	6	+5V
7	LIM-OUTA	24	n.c.	7	+5V
8	KA2	25	AMPB2 (68Ω/⊥)	8	LED-STANDBY
9	n.c.	26	GND-D		
10	KA3	27	GND-D		
11	POWER-ON	28	GND-D		
12	KA4	29	GND-D		
13	STBYLED	30	AID5 (10Ω/⊥)		
14	KA5	31	AID4		
15	TIMER	32	AID3		
16	n.c.	33	AID2		
17	RELAYDRV	34	AID1		

### 16. Amplifier-ID

AID1:	1	MSB
AID2:	1	↓
AID3:	1	↓
AID4:	1	↓
AID5:	0	LSB

Bin: 11110

Hex: 1E



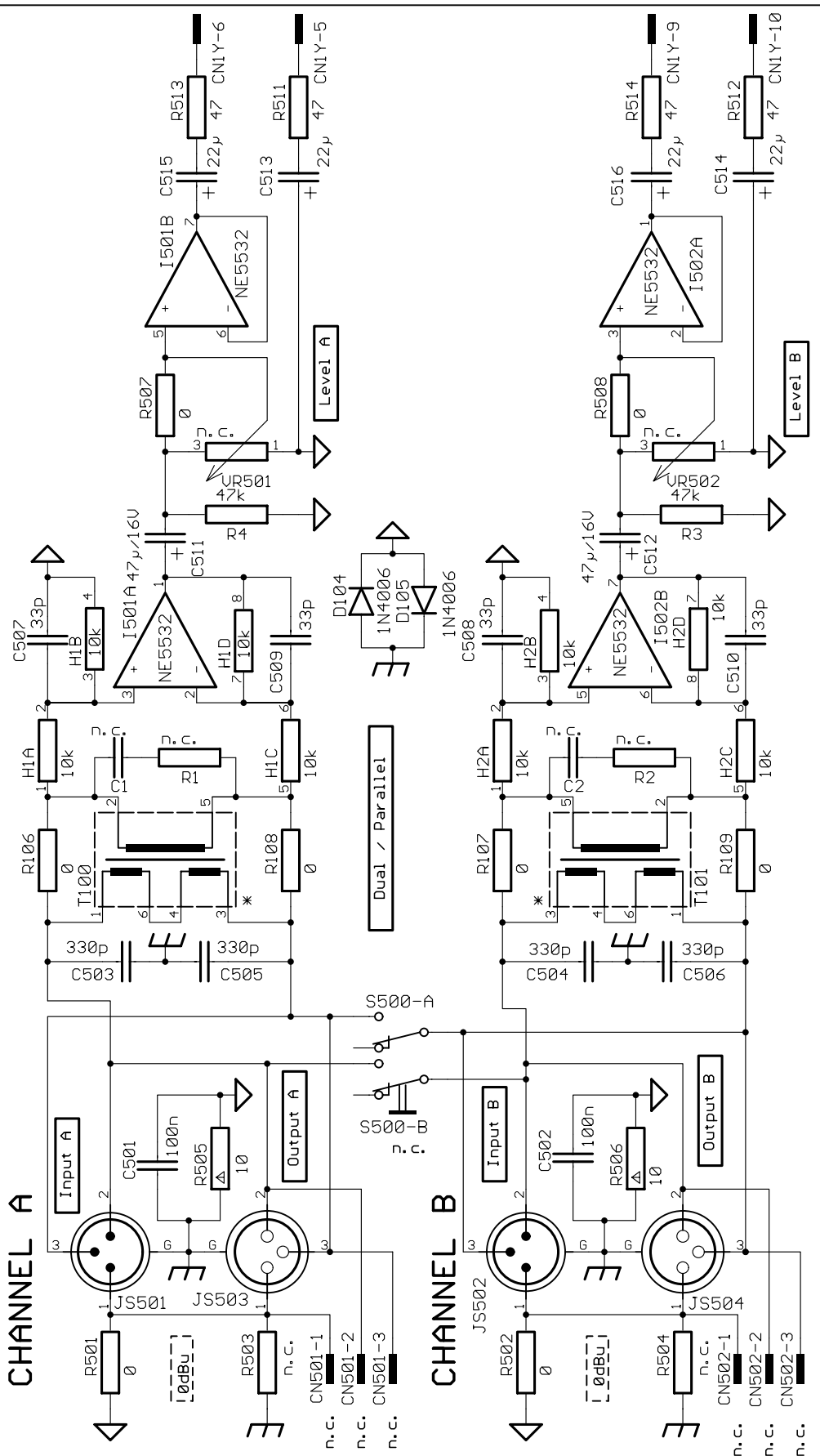
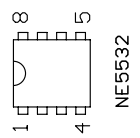
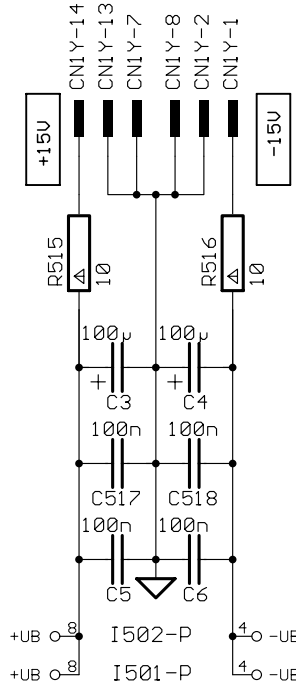

ALTERATIONS RESERVED!

				Last modified: 26.10.1999 13:20:06		<b>81344B</b> Input PCB Xi-11		
				Last plotted: 09.05.2001 13:03:25				
				DATE	NAME	<b>CIRCUIT DIAGRAM</b>  <b>X-AMPS</b> 356 891		
				DSG'D	29.06.99			Lang F.
				CHK'D				
				APP'D				
<b>EVI AUDIO</b>						4-		
ISSUE	REVISION	DATE	NAME					

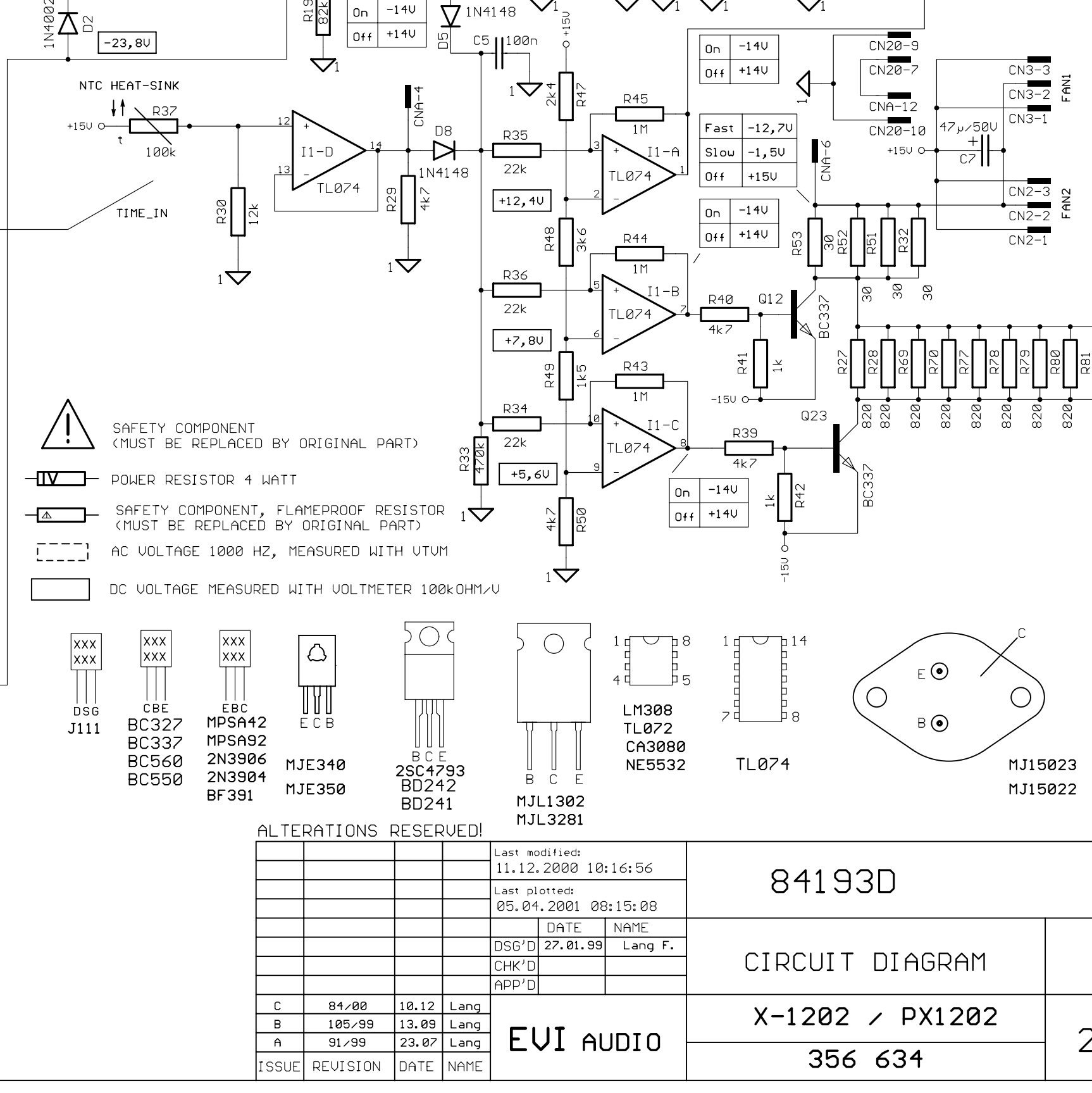
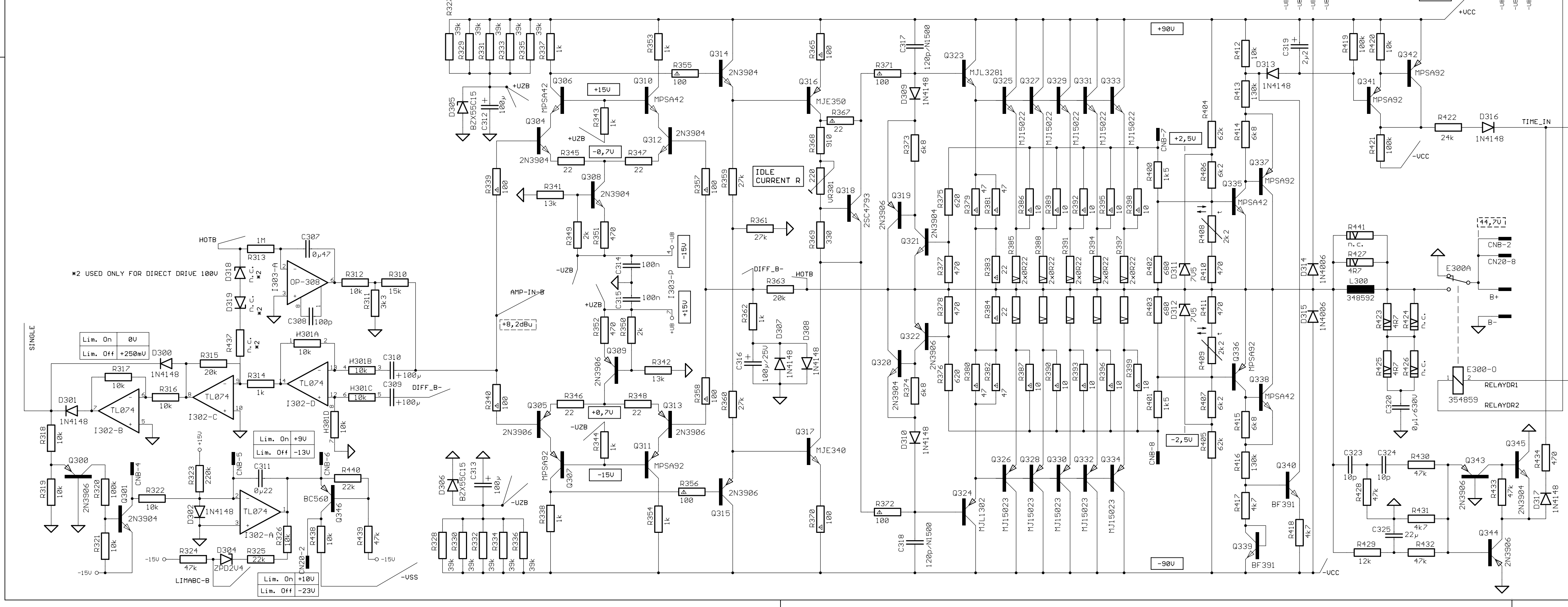
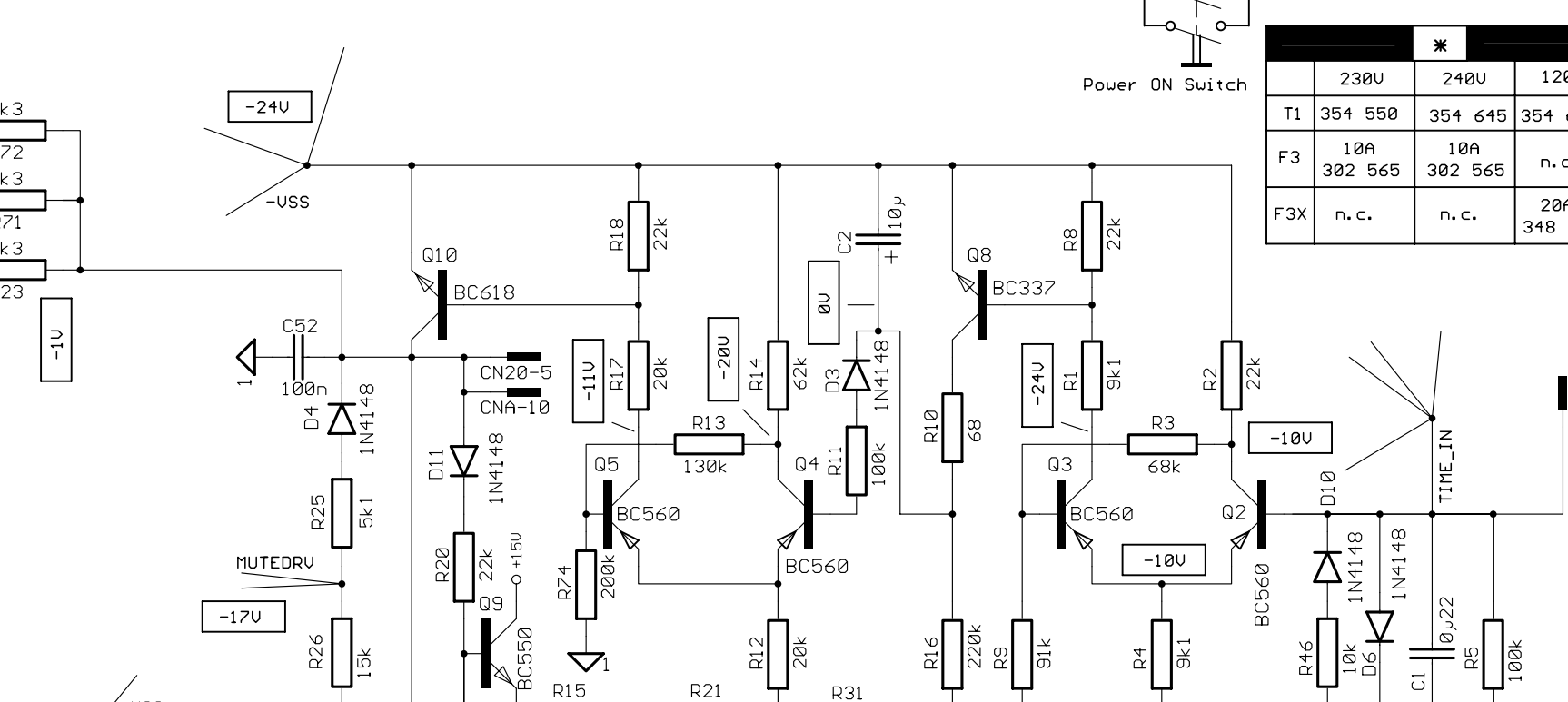
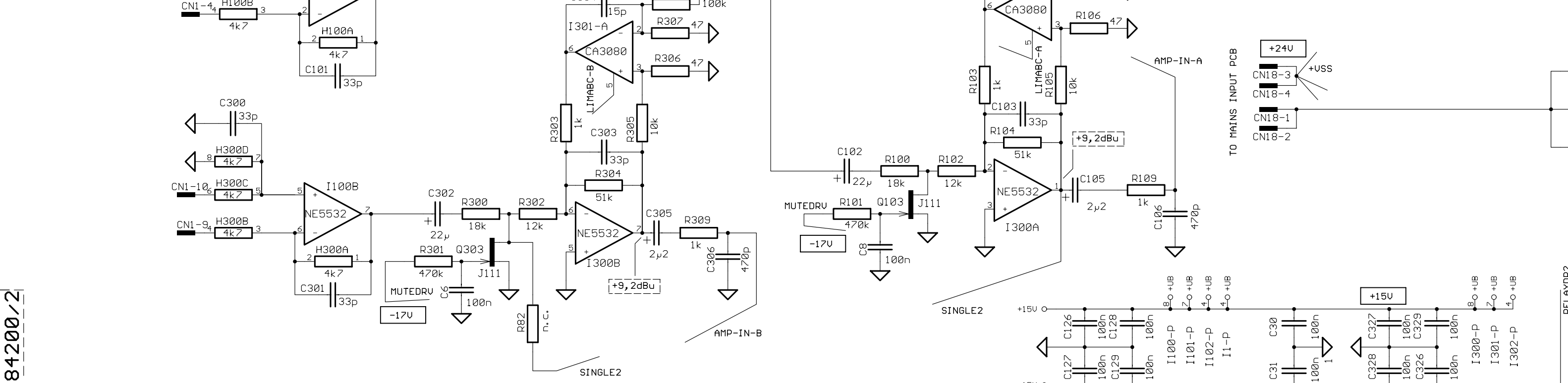
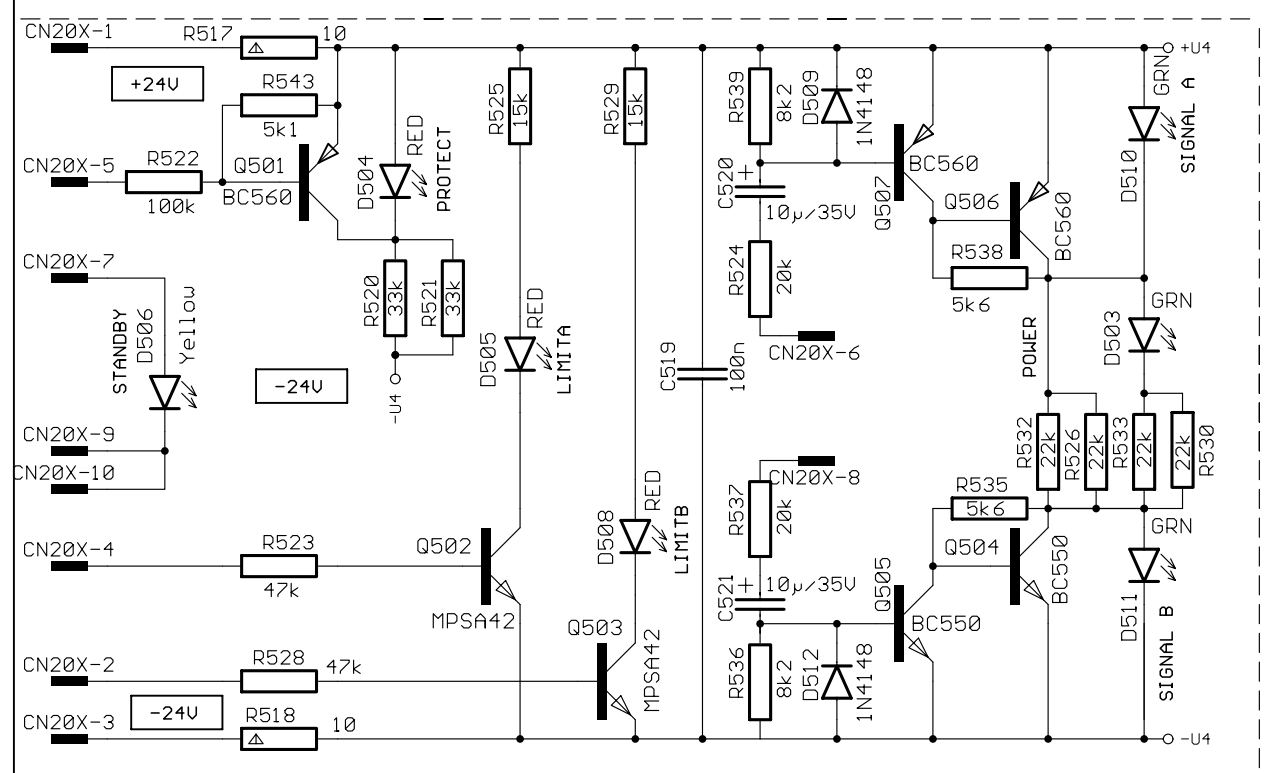
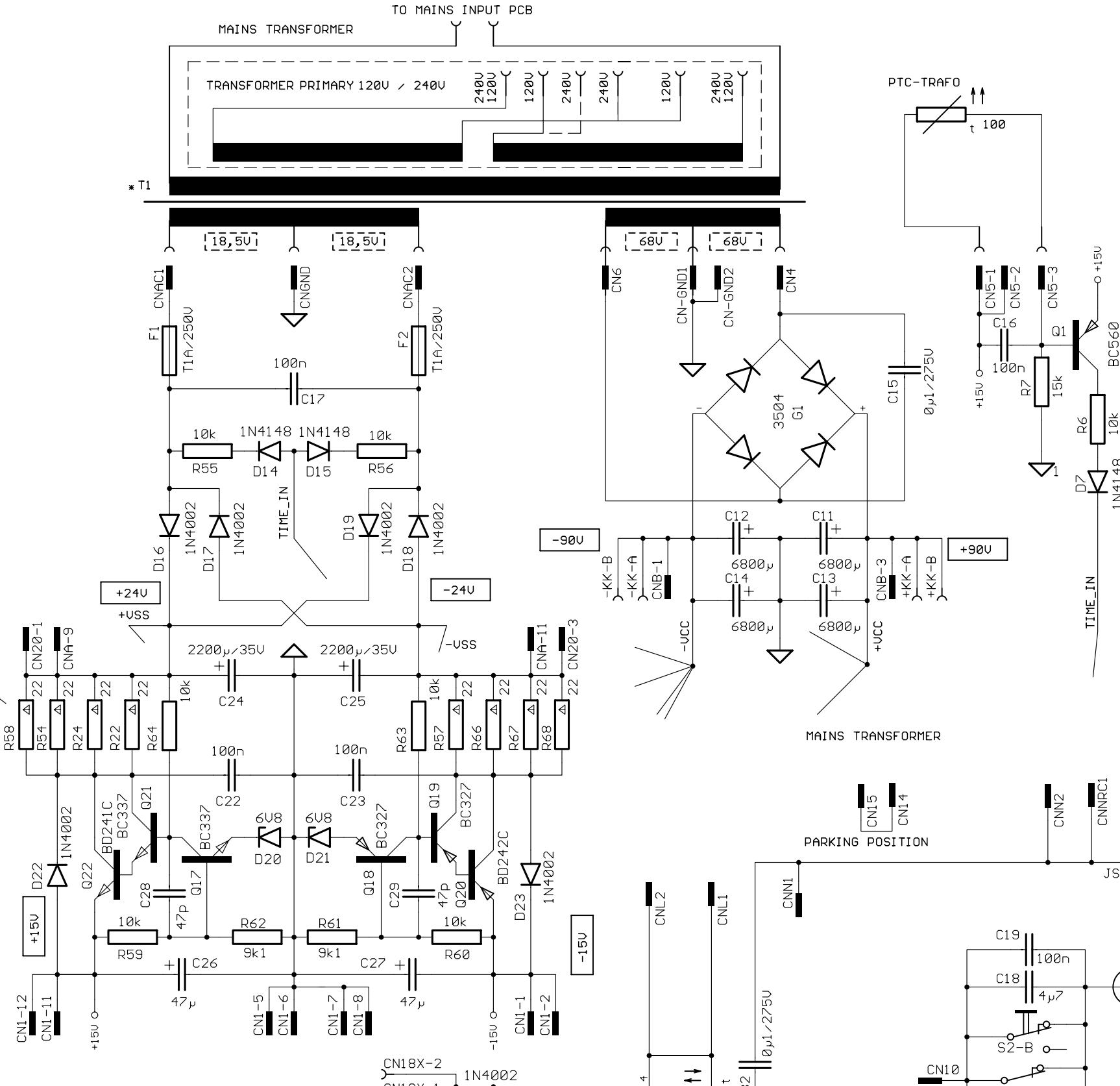
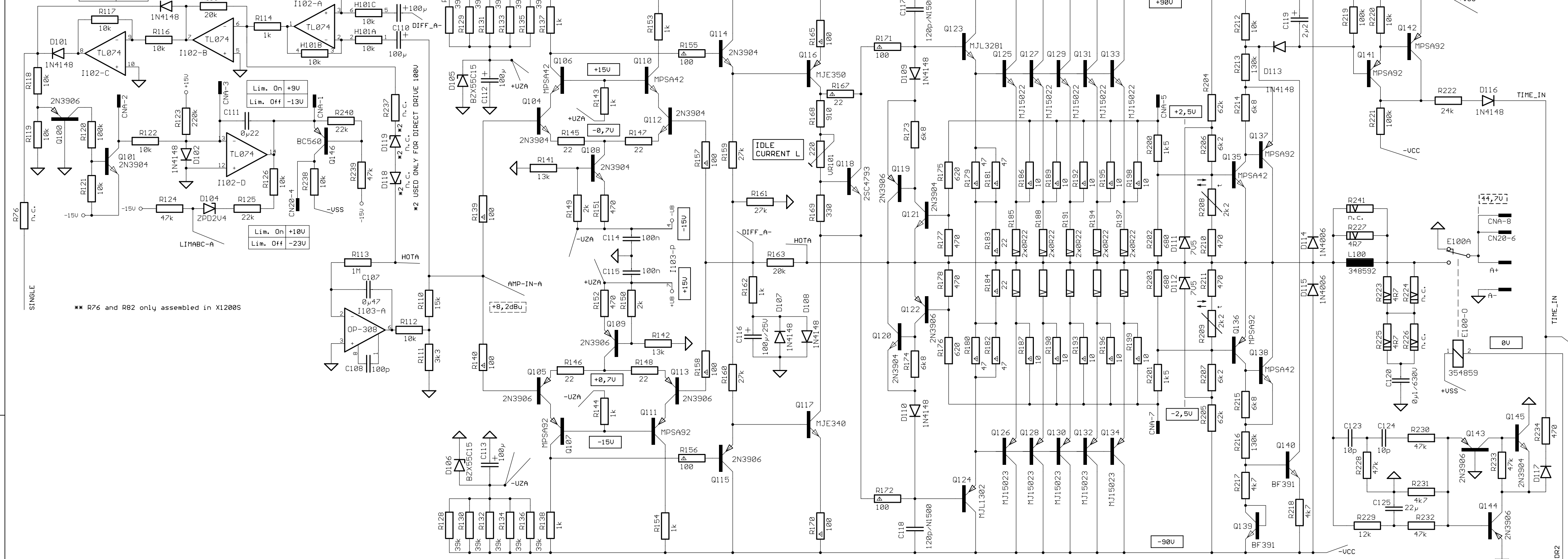

- SAFETY COMPONENT (MUST BE REPLACED BY ORIGINAL PART)
- POWER RESISTOR 4 WATT
- SAFETY COMPONENT, FLAMEPROOF RESISTOR (MUST BE REPLACED BY ORIGINAL PART)
- AC VOLTAGE 1000 Hz, MEASURED WITH UTM
- DC VOLTAGE MEASURED WITH VOLTMETER 100k OHM/V

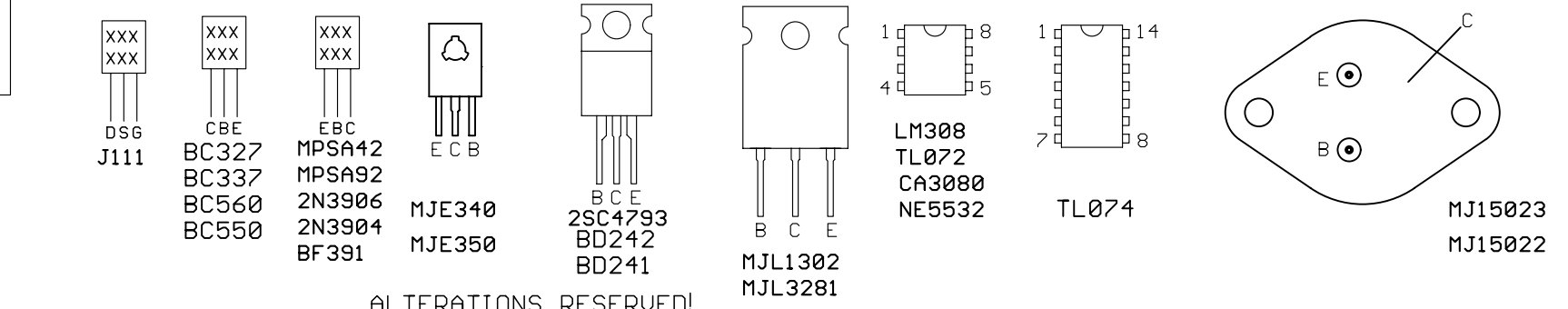

ALTERATIONS RESERVED!		Last modified: 11.12.2000 10:16:56	
		Last plotted: 05.04.2001 08:15:08	
	DATE	NAME	
DSG/D	27.01.99	Lang F.	
CHK/D			
APP/D			
C	84/08	18.12	Lang
B	105/99	13.09	Lang
A	91/99	23.07	Lang

84193D

CIRCUIT DIAGRAM

X-1202 / PX1202

356 634

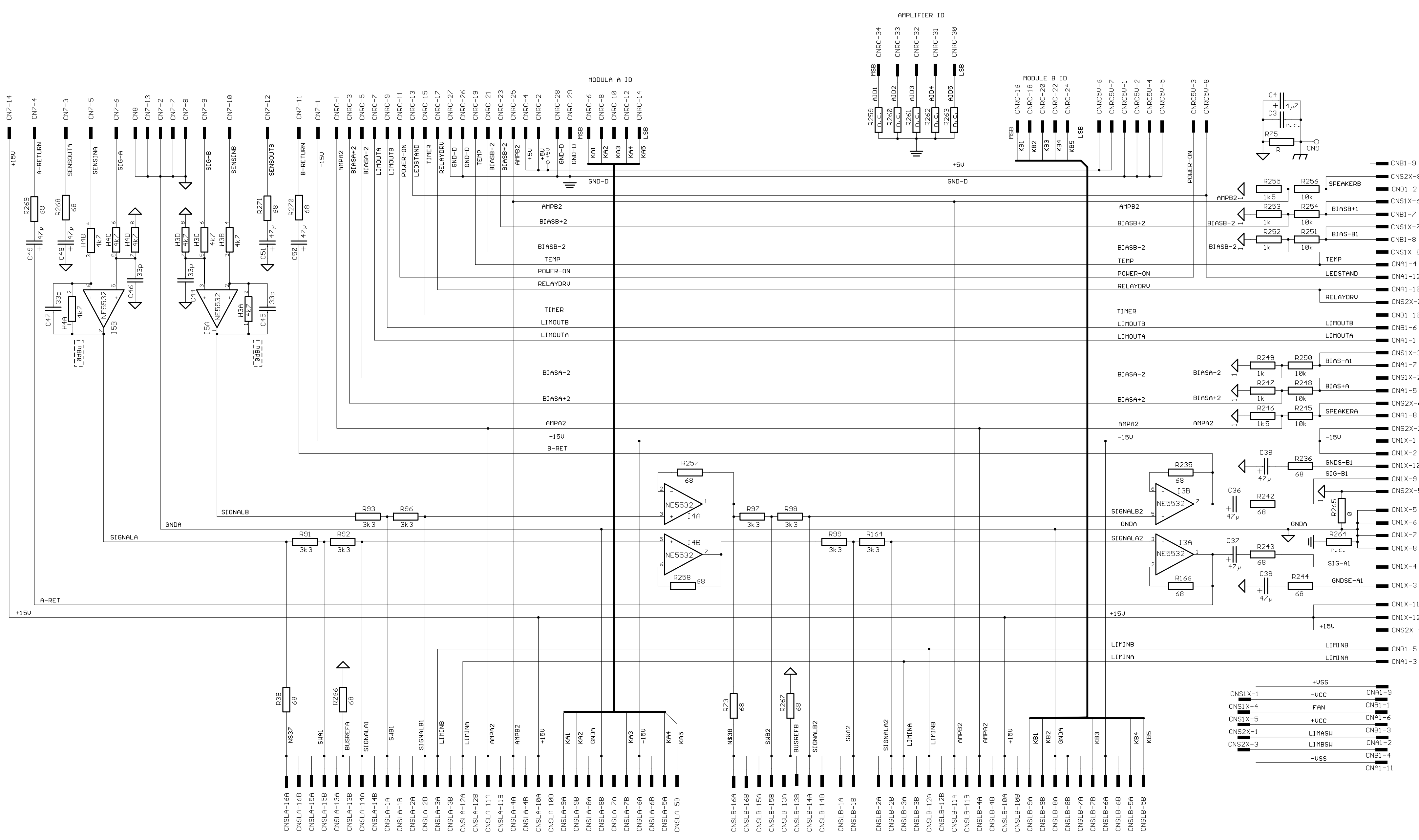

ALTERATIONS RESERVED!				Last modified: 11.12.2000 10:16:56	
				Last plotted: 05.04.2001 08:26:21	
				DATE	NAME
				DSG'D	
				CHK'D	
				APP'D	
C	84/00	10.12	Lang	EVI AUDIO	
A	91/99	23.07	Lang		
ISSUE	REVISION	DATE	NAME		
				84193D	
				CIRCUIT DIAGRAM	
				X-1202 / PX1202	
				356 635	
				2/2	
				3-	

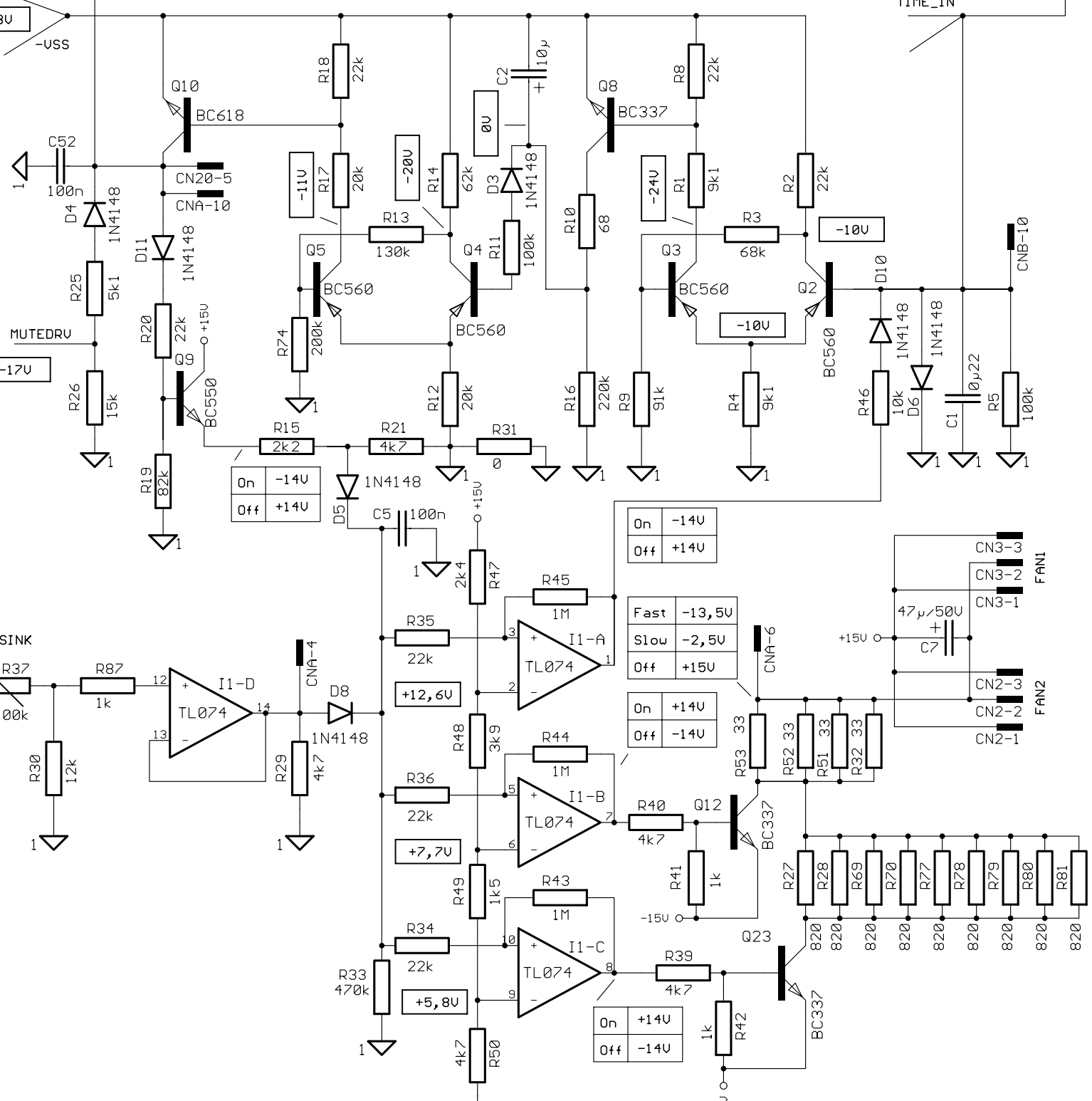
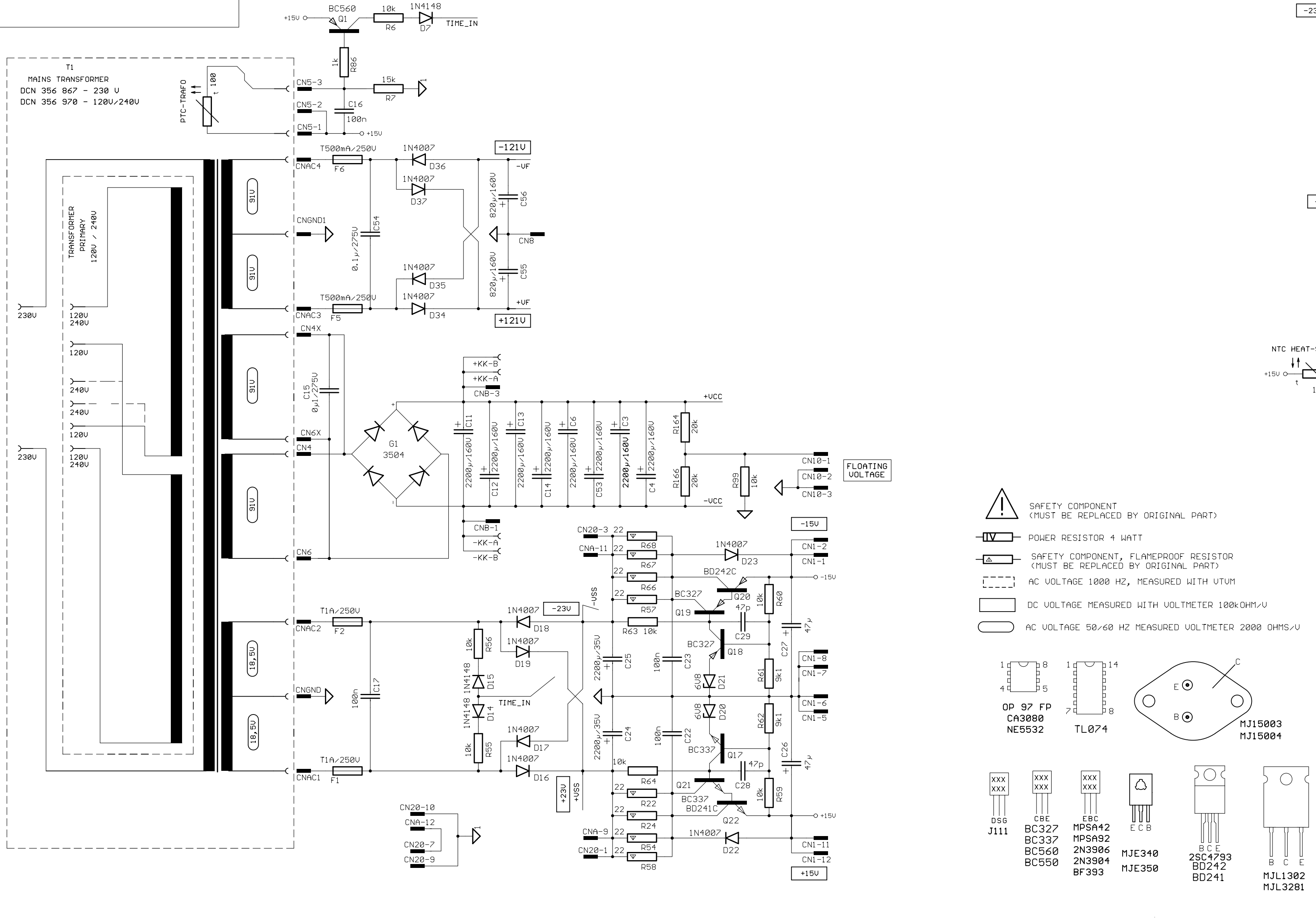
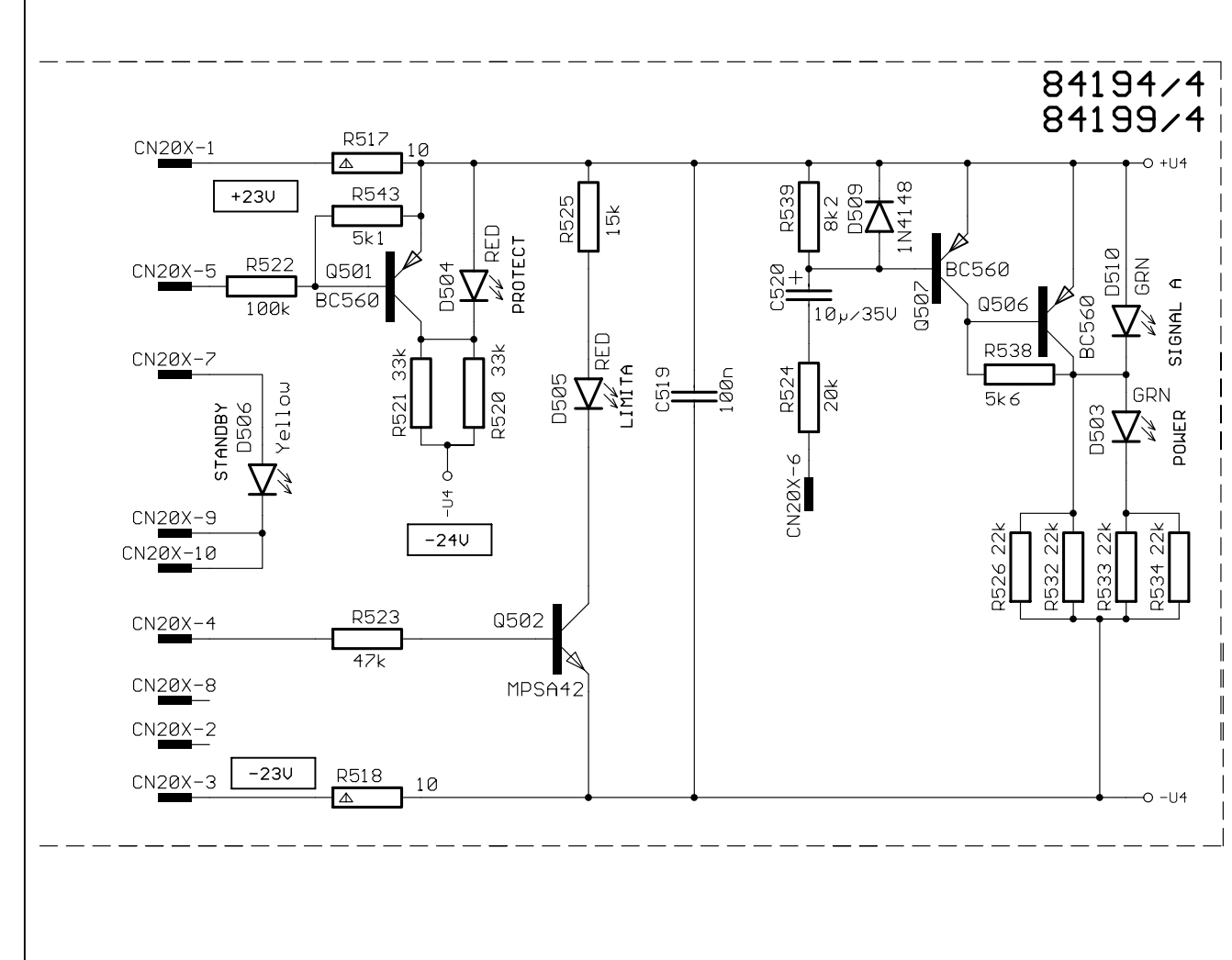
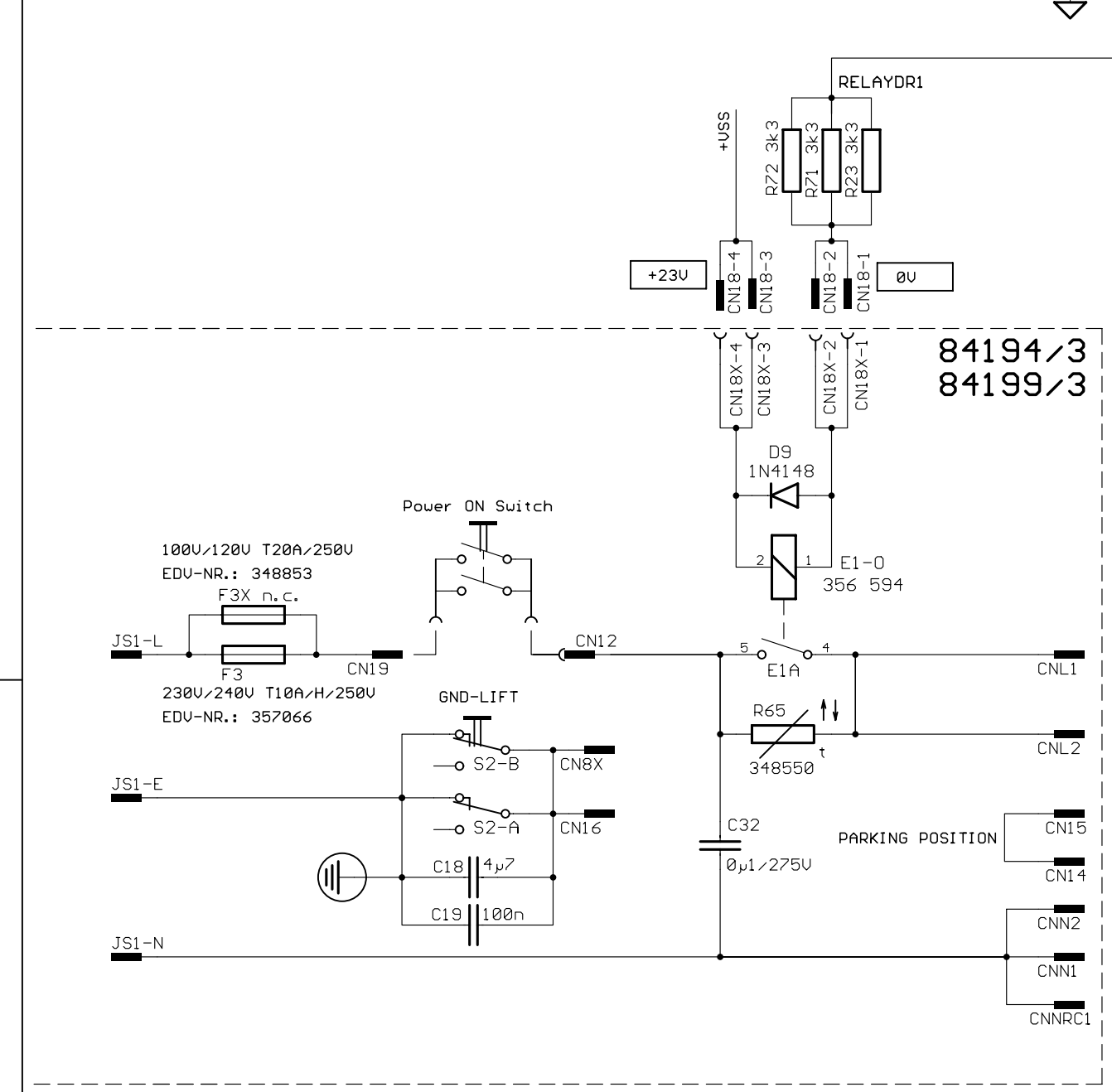
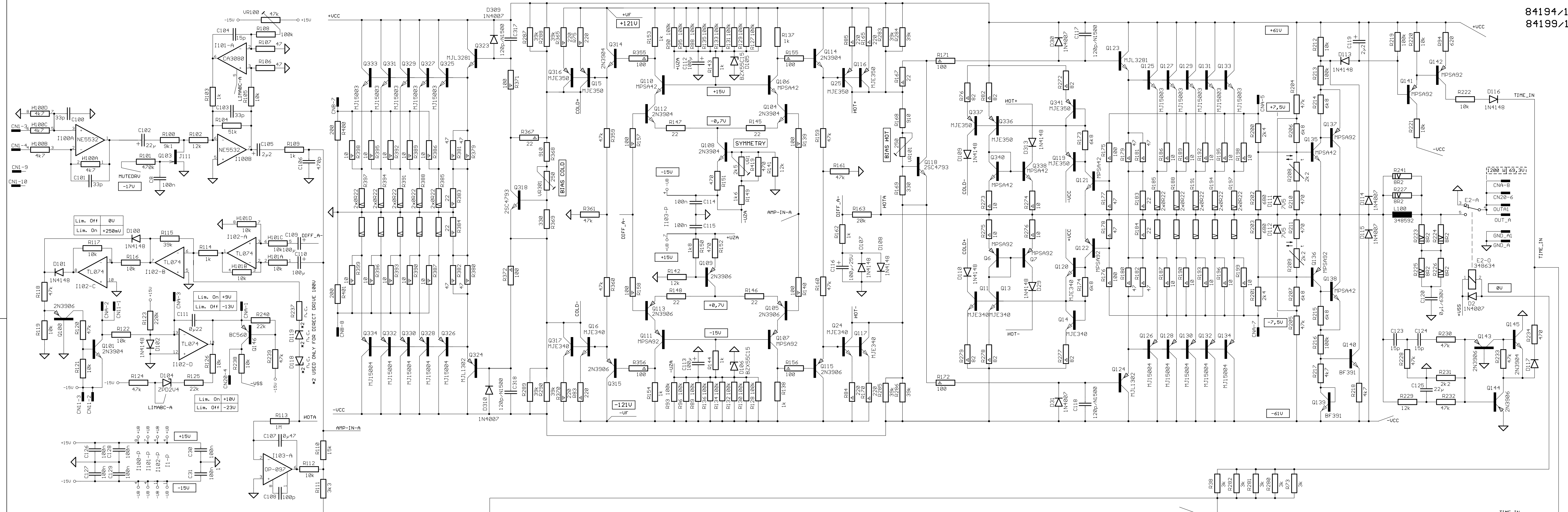

- SAFETY COMPONENT (MUST BE REPLACED BY ORIGINAL PART)
- POWER RESISTOR 4 WATT
- SAFETY COMPONENT, FLAME-PROOF RESISTOR (MUST BE REPLACED BY ORIGINAL PART)
- AC VOLTAGE 1000 HZ, MEASURED WITH UTM
- DC VOLTAGE MEASURED WITH VOLTMETER 100k OHM/V
- AC VOLTAGE 50-60 HZ MEASURED VOLTMETER 2000 OHMS/V

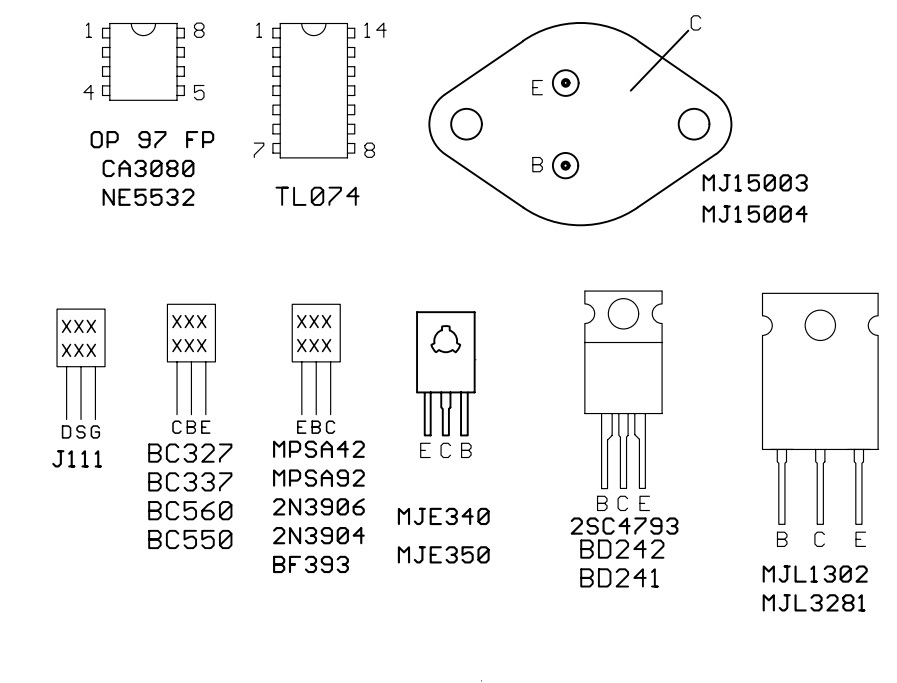

ALTERATIONS RESERVED!

REV	DATE	NAME
1	11.12.2000	10:47:50
2	05.04.2001	08:14:08
3	1999	Stangl
4	21.06	Stangl
5	CHK'D	
6	DSG'D	
7	18.12	Lang
8	01.00	05.01
9	105/99	13.09
10	90/99	23.07

84194d	
CIRCUIT DIAGRAM	
356 631	
X1201 / PX1201	



**Ersatzteilliste - Bill of Materials**

<b>170149 P 1201 230V</b>			
<b>Pos. Nr.</b>	<b>Best. Nr.</b>		
<b>Ref. No.</b>	<b>Part No.</b>	<b>Bezeichnung</b>	<b>Description</b>

<b>Zubehör</b>		<b>Accessories &amp; packing material</b>	
359919	OWNER'S MANUAL P 1201/2	owner's manual	
335589	FUSS-GUMMI SJ 5009 SW	rubber foot	
300425	KABEL-NETZ 2.0 M 10A	power cable Europe	
337053	SCHUTZHÜLLE 650X800X0,08	poly bag	
306482	KRT. 2 HE 556X507X178	carton	
357751	STYROPOR-EINLAGE X1201	filler, carton, foam	
355742	STYROPOR-PL. 500X370X20	filler, carton, foam	

<b>Mechanische Teile</b>		<b>Cabinet material</b>	
B0010	341343	BUCHSE-SPEAKON-VIERECK 4POL	speaker socket 4-pole
G0010	343270	GLRI GBPC 3504	rectifier GBPC-P 3504
S0010	346720	SCHALTER-NETZ ESB-99888V	power switch
	341382	KNOPF-TASTE 20X8 SW 3.3	push button black
	351214	GRIFF 109 MM GRAU 3HE	handle 109 mm
	348415	LÜFTER TYP FBA08A24H DC	fan dc 24V
	348387	KABEL-KONFEKT 10POL 0.300M	ribbon cable assy 10-way
	349610	KABEL-KONFEKT 10POL 0.520M	ribbon cable assy 10-way
	356956	KABEL-KONFEKT 12POL 0.320M	ribbon cable assy 12-way
	354999	KABEL-KONFEKT 12POL 0.350M	ribbon cable assy 12-way
	356957	KABEL-KONFEKT 4POL 0.420M	ribbon cable assy 4-way
	356663	KABEL-KONFEKT 14POL 0.250M	ribbon cable assy 14-way
	359962	FB.P 1201 BED	front panel P 1201
	359963	RW.P1201/230V BED	rear panel P1201
	351359	DEC.3HE-EV-LACK/P2-3000 LAC	top cover
	359917	BLEND.P1201/2 LEER LAC	blank panel
	359965	BLEND.O-1 BED	panel 0-1
	359966	BLEND.I-11 BED	panel I-11
	356867	RKT X1201/P1201 230V	mains transformer 230V
	348805	WI-SO PTC K155 100GRAD	safety component PTC
	348341	FEDERLEISTE 3POL CE100-	connector female 3-pole

<b>813448 PCBAR:X1201/X1202 N 5</b>		<b>input pcb assy</b>	
CN01Y	356660	STIFTLAISTE 2X 7POL 1-	connector male 7x2 pins
C0003	340524	KO-EL 100.000MF 16V	cap electrolytic 100uF/16V
C0004	340524	KO-EL 100.000MF 16V	cap electrolytic 100uF/16V
C0005	329021	KO-KER 0.10MF 100V 20%	cap ceramic 100nF
C0006	329021	KO-KER 0.10MF 100V 20%	cap ceramic 100nF
C0501	329021	KO-KER 0.10MF 100V 20%	cap ceramic 100nF
C0502	329021	KO-KER 0.10MF 100V 20%	cap ceramic 100nF
C0503	301543	KO-KER 330.0PF 500V 10%	cap ceramic 330pF
C0504	301543	KO-KER 330.0PF 500V 10%	cap ceramic 330pF
C0505	301543	KO-KER 330.0PF 500V 10%	cap ceramic 330pF
C0506	301543	KO-KER 330.0PF 500V 10%	cap ceramic 330pF
C0507	301558	KO-KER 33.0PF 100V 2%	cap ceramic 33pF
C0508	301558	KO-KER 33.0PF 100V 2%	cap ceramic 33pF

Pos. Nr. Ref. No.	Best. Nr. Part No.	Bezeichnung	Description
C0509	301558	KO-KER 33.0PF 100V 2%	cap ceramic 33pF
C0510	301558	KO-KER 33.0PF 100V 2%	cap ceramic 33pF
C0511	346841	KO-EL 47.000MF 16V	cap electrolytic 47uF/16V
C0512	346841	KO-EL 47.000MF 16V	cap electrolytic 47uF/16V
C0513	340523	KO-EL 22.000MF 16V	cap electrolytic 22uF/16V
C0514	340523	KO-EL 22.000MF 16V	cap electrolytic 22uF/16V
C0515	340523	KO-EL 22.000MF 16V	cap electrolytic 22uF/16V
C0516	340523	KO-EL 22.000MF 16V	cap electrolytic 22uF/16V
C0517	329021	KO-KER 0.10MF 100V 20%	cap ceramic 100nF
C0518	329021	KO-KER 0.10MF 100V 20%	cap ceramic 100nF
D0501	304360	DIODE 1N 4007 GEGURTET	diode 1N 4002
D0502	304360	DIODE 1N 4007 GEGURTET	diode 1N 4002
H0001	343457	DICKS-NETZW. 8PIN 2%	res.network 8x10k Ohm
H0002	343457	DICKS-NETZW. 8PIN 2%	res.network 8x10k Ohm
I0501	327197	IC NE 5532 P 2FACH OP	IC NE 5532 N
I0502	327197	IC NE 5532 P 2FACH OP	IC NE 5532 N
JS501	351815	BUCHSE-FL. XLR 3POL PRINTB	xlr connector female 3-pole
JS502	351815	BUCHSE-FL. XLR 3POL PRINTB	xlr connector female 3-pole
JS503	351816	STECKER-FL. XLR 3POL PRINTB	xlr connector male 3-pin
JS504	351816	STECKER-FL. XLR 3POL PRINTB	xlr connector male 3-pin
R0515	329215	WI-SI 10.00 OHM 0.30W 5%	safety resistor 10.0 Ohm
R0516	329215	WI-SI 10.00 OHM 0.30W 5%	safety resistor 10.0 Ohm

<b>841948</b>	<b>PCBAR#X 1201</b>	<b>power amp pcb assy</b>
---------------	---------------------	---------------------------

CNAC1	343516	FL.STECKER 4.8/0.5	connector 4.8mm faston
CNAC2	343516	FL.STECKER 4.8/0.5	connector 4.8mm faston
CNAC3	343516	FL.STECKER 4.8/0.5	connector 4.8mm faston
CNAC4	343516	FL.STECKER 4.8/0.5	connector 4.8mm faston
CNA00	348802	MESSERLST. 12POL	connector male 12-pin
CNA01	348802	MESSERLST. 12POL	connector male 12-pin
CNB00	344975	MESSERLST. 10POL	connector male 10-pin
CNB01	344975	MESSERLST. 10POL	connector male 10-pin
CNGND	343516	FL.STECKER 4.8/0.5	connector 4.8mm faston
CNL01	330269	FL.STECKER 6.3/0.8	connector 6.3mm faston
CNL02	330269	FL.STECKER 6.3/0.8	connector 6.3mm faston
CNNRC	330269	FL.STECKER 6.3/0.8	connector 6.3mm faston
CNN01	330269	FL.STECKER 6.3/0.8	connector 6.3mm faston
CNN02	330269	FL.STECKER 6.3/0.8	connector 6.3mm faston
CNRC5	344862	MESSERLST. 8POL	connector male 8-pin
CNSLA	352158	MESSERLST. 32POL	connector male 32-pin
CNSO1	354306	STIFTLEISTE 16POL	connector male 16-pin
CN001	348802	MESSERLST. 12POL	connector male 12-pin
CN002	348334	STIFTLEISTE 3POL MLSS	connector male 3-pin
CN003	348334	STIFTLEISTE 3POL MLSS	connector male 3-pin
CN004	330269	FL.STECKER 6.3/0.8	connector 6.3mm faston
CN005	348334	STIFTLEISTE 3POL MLSS	connector male 3-pin
CN006	330269	FL.STECKER 6.3/0.8	connector 6.3mm faston
CN007	356660	STIFTLEISTE 2X 7POL 1-	connector male 7x2 pins
CN008	343516	FL.STECKER 4.8/0.5	connector 4.8mm faston
CN01X	348802	MESSERLST. 12POL	connector male 12-pin
CN010	348334	STIFTLEISTE 3POL MLSS	connector male 3-pin
CN011	348334	STIFTLEISTE 3POL MLSS	connector male 3-pin

Pos. Nr. Ref. No.	Best. Nr. Part No.	Bezeichnung	Description
CN012	330269	FL.STECKER 6.3/0.8	connector 6.3mm faston
CN013	330269	FL.STECKER 6.3/0.8	connector 6.3mm faston
CN014	330269	FL.STECKER 6.3/0.8	connector 6.3mm faston
CN015	330269	FL.STECKER 6.3/0.8	connector 6.3mm faston
CN016	330269	FL.STECKER 6.3/0.8	connector 6.3mm faston
CN018	341937	MESSERLST. 4POL	connector male 4-pin
CN019	330269	FL.STECKER 6.3/0.8	connector 6.3mm faston
CN020	344975	MESSERLST. 10POL	connector male 10-pin
CN18X	341937	MESSERLST. 4POL	connector male 4-pin
CN20X	344975	MESSERLST. 10POL	connector male 10-pin
C0001	342923	KO-FOL 0.220MF 63V 5%	cap mylar 220nF
C0002	307445	KO-EL 10.000MF 35V	cap electrolytic 10uF/35V
C0003	348458	KO-EL 2200.000MF 160V	cap electrolytic 2200uF/160
C0004	348458	KO-EL 2200.000MF 160V	cap electrolytic 2200uF/160
C0005	329021	KO-KER 0.10MF 100V 20%	cap ceramic 100nF
C0006	348458	KO-EL 2200.000MF 160V	cap electrolytic 2200uF/160
C0007	343530	KO-EL 47.000MF 50V	cap electrolytic 47uF/50V
C0008	329021	KO-KER 0.10MF 100V 20%	cap ceramic 100nF
C0010	327366	KO-EL 4.700MF 50V BIP	cap bip electr. 4.7uF/50V
C0011	348458	KO-EL 2200.000MF 160V	cap electrolytic 2200uF/160
C0012	348458	KO-EL 2200.000MF 160V	cap electrolytic 2200uF/160
C0013	348458	KO-EL 2200.000MF 160V	cap electrolytic 2200uF/160
C0014	348458	KO-EL 2200.000MF 160V	cap electrolytic 2200uF/160
C0015	341714	KO-SO 0.10MF 275V 20% K	safety cap 100nF/275V
C0016	329021	KO-KER 0.10MF 100V 20%	cap ceramic 100nF
C0017	329021	KO-KER 0.10MF 100V 20%	cap ceramic 100nF
C0018	327366	KO-EL 4.700MF 50V BIP	cap bip electr. 4.7uF/50V
C0019	329021	KO-KER 0.10MF 100V 20%	cap ceramic 100nF
C0020	343530	KO-EL 47.000MF 50V	cap electrolytic 47uF/50V
C0021	343530	KO-EL 47.000MF 50V	cap electrolytic 47uF/50V
C0022	329021	KO-KER 0.10MF 100V 20%	cap ceramic 100nF
C0023	329021	KO-KER 0.10MF 100V 20%	cap ceramic 100nF
C0024	335935	KO-EL 2200.000MF 35V	cap electrolytic 2200uF/35V
C0025	335935	KO-EL 2200.000MF 35V	cap electrolytic 2200uF/35V
C0026	343530	KO-EL 47.000MF 50V	cap electrolytic 47uF/50V
C0027	343530	KO-EL 47.000MF 50V	cap electrolytic 47uF/50V
C0028	301524	KO-KER 47.0PF 500V 10%	cap ceramic 47pF
C0029	301524	KO-KER 47.0PF 500V 10%	cap ceramic 47pF
C0030	329021	KO-KER 0.10MF 100V 20%	cap ceramic 100nF
C0031	329021	KO-KER 0.10MF 100V 20%	cap ceramic 100nF
C0032	341714	KO-SO 0.10MF 275V 20% K	safety cap 100nF/275V
C0033	301558	KO-KER 33.0PF 100V 2%	cap ceramic 33pF
C0037	343530	KO-EL 47.000MF 50V	cap electrolytic 47uF/50V
C0039	343530	KO-EL 47.000MF 50V	cap electrolytic 47uF/50V
C0042	329021	KO-KER 0.10MF 100V 20%	cap ceramic 100nF
C0043	329021	KO-KER 0.10MF 100V 20%	cap ceramic 100nF
C0044	301558	KO-KER 33.0PF 100V 2%	cap ceramic 33pF
C0045	301558	KO-KER 33.0PF 100V 2%	cap ceramic 33pF
C0046	301558	KO-KER 33.0PF 100V 2%	cap ceramic 33pF
C0047	301558	KO-KER 33.0PF 100V 2%	cap ceramic 33pF
C0048	343530	KO-EL 47.000MF 50V	cap electrolytic 47uF/50V
C0049	343530	KO-EL 47.000MF 50V	cap electrolytic 47uF/50V
C0052	329021	KO-KER 0.10MF 100V 20%	cap ceramic 100nF



Pos. Nr. Ref. No.	Best. Nr. Part No.	Bezeichnung	Description
C0053	348458	KO-EL 2200.000MF 160V	cap electrolytic 2200uF/160
C0054	341714	KO-SO 0.10MF 275V 20% K	safety cap 100nF/275V
C0055	348459	KO-EL 820.000MF 160V	cap electrolytic 820uF/160V
C0056	348459	KO-EL 820.000MF 160V	cap electrolytic 820uF/160V
C0100	301558	KO-KER 33.0PF 100V 2%	cap ceramic 33pF
C0101	301558	KO-KER 33.0PF 100V 2%	cap ceramic 33pF
C0102	301478	KO-EL 22.000MF 63V	cap electrolytic 22uF/63V
C0103	301558	KO-KER 33.0PF 100V 2%	cap ceramic 33pF
C0104	335787	KO-KER 15.0PF 100V 2%	cap ceramic 15pF
C0105	301458	KO-EL 2.200MF 63V	cap electrolytic 2.2uF/63V
C0106	327390	KO-FOL 470.000PF 100V 5%	cap mylar 470pF
C0107	340988	KO-FOL 0.470MF 63V 5%	cap mylar 470nF
C0108	301530	KO-KER 100.0PF 500V 10%	cap ceramic 100pF
C0109	343532	KO-EL 100.000MF 25V	cap electrolytic 100uF/25V
C0110	343532	KO-EL 100.000MF 25V	cap electrolytic 100uF/25V
C0111	342923	KO-FOL 0.220MF 63V 5%	cap mylar 220nF
C0112	343532	KO-EL 100.000MF 25V	cap electrolytic 100uF/25V
C0113	343532	KO-EL 100.000MF 25V	cap electrolytic 100uF/25V
C0114	329021	KO-KER 0.10MF 100V 20%	cap ceramic 100nF
C0115	329021	KO-KER 0.10MF 100V 20%	cap ceramic 100nF
C0116	343532	KO-EL 100.000MF 25V	cap electrolytic 100uF/25V
C0117	351994	KO-KER 120.0PF 500V 2%	cap ceramic 120pF
C0118	351994	KO-KER 120.0PF 500V 2%	cap ceramic 120pF
C0119	301458	KO-EL 2.200MF 63V	cap electrolytic 2.2uF/63V
C0120	356605	KO-FOL 0.100MF 250V 5%	cap mylar 100nF
C0123	335787	KO-KER 15.0PF 100V 2%	cap ceramic 15pF
C0124	335787	KO-KER 15.0PF 100V 2%	cap ceramic 15pF
C0125	301474	KO-EL 22.000MF 16V BIP	cap bip electr. 22uF/16V
C0126	329021	KO-KER 0.10MF 100V 20%	cap ceramic 100nF
C0127	329021	KO-KER 0.10MF 100V 20%	cap ceramic 100nF
C0128	329021	KO-KER 0.10MF 100V 20%	cap ceramic 100nF
C0129	329021	KO-KER 0.10MF 100V 20%	cap ceramic 100nF
C0317	351994	KO-KER 120.0PF 500V 2%	cap ceramic 120pF
C0318	351994	KO-KER 120.0PF 500V 2%	cap ceramic 120pF
C0519	329021	KO-KER 0.10MF 100V 20%	cap ceramic 100nF
C0520	340522	KO-EL 10.000MF 35V	cap electrolytic 10uF/35V
D0002	304360	DIODE 1N 4007 GEGURTET	diode 1N 4002
D0003	301254	DIODE 1N 4148 AXIAL	diode 1N 4148
D0004	301254	DIODE 1N 4148 AXIAL	diode 1N 4148
D0005	301254	DIODE 1N 4148 AXIAL	diode 1N 4148
D0006	301254	DIODE 1N 4148 AXIAL	diode 1N 4148
D0007	301254	DIODE 1N 4148 AXIAL	diode 1N 4148
D0008	301254	DIODE 1N 4148 AXIAL	diode 1N 4148
D0009	301254	DIODE 1N 4148 AXIAL	diode 1N 4148
D0010	301254	DIODE 1N 4148 AXIAL	diode 1N 4148
D0011	301254	DIODE 1N 4148 AXIAL	diode 1N 4148
D0014	301254	DIODE 1N 4148 AXIAL	diode 1N 4148
D0015	301254	DIODE 1N 4148 AXIAL	diode 1N 4148
D0016	304360	DIODE 1N 4007 GEGURTET	diode 1N 4002
D0017	304360	DIODE 1N 4007 GEGURTET	diode 1N 4002
D0018	304360	DIODE 1N 4007 GEGURTET	diode 1N 4002
D0019	304360	DIODE 1N 4007 GEGURTET	diode 1N 4002
D0020	304992	DIODZ BZX 55C 6V8 0.50W	diode zener 6V8

Pos. Nr. Ref. No.	Best. Nr. Part No.	Bezeichnung	Description
D0021	304992	DIODZ BZX 55C 6V8 0.50W	diode zener 6V8
D0022	304360	DIODE 1N 4007 GEGURTET	diode 1N 4002
D0023	304360	DIODE 1N 4007 GEGURTET	diode 1N 4002
D0029	301254	DIODE 1N 4148 AXIAL	diode 1N 4148
D0030	304360	DIODE 1N 4007 GEGURTET	diode 1N 4002
D0031	304360	DIODE 1N 4007 GEGURTET	diode 1N 4002
D0034	304360	DIODE 1N 4007 GEGURTET	diode 1N 4002
D0035	304360	DIODE 1N 4007 GEGURTET	diode 1N 4002
D0036	304360	DIODE 1N 4007 GEGURTET	diode 1N 4002
D0037	304360	DIODE 1N 4007 GEGURTET	diode 1N 4002
D0100	301254	DIODE 1N 4148 AXIAL	diode 1N 4148
D0101	301254	DIODE 1N 4148 AXIAL	diode 1N 4148
D0102	301254	DIODE 1N 4148 AXIAL	diode 1N 4148
D0104	329511	DIODZ BZX 55C 2V4 0.50W	diode zener 2V4
D0105	309450	DIODZ BZX 55C 15V 0.50W	diode zener 15V
D0106	309450	DIODZ BZX 55C 15V 0.50W	diode zener 15V
D0107	301254	DIODE 1N 4148 AXIAL	diode 1N 4148
D0108	301254	DIODE 1N 4148 AXIAL	diode 1N 4148
D0109	301254	DIODE 1N 4148 AXIAL	diode 1N 4148
D0110	301254	DIODE 1N 4148 AXIAL	diode 1N 4148
D0111	307916	DIODZ BZX 55C 7V5 0.50W	diode zener 7V5
D0112	307916	DIODZ BZX 55C 7V5 0.50W	diode zener 7V5
D0113	301254	DIODE 1N 4148 AXIAL	diode 1N 4148
D0114	304360	DIODE 1N 4007 GEGURTET	diode 1N 4002
D0115	304360	DIODE 1N 4007 GEGURTET	diode 1N 4002
D0116	301254	DIODE 1N 4148 AXIAL	diode 1N 4148
D0117	301254	DIODE 1N 4148 AXIAL	diode 1N 4148
D0309	304360	DIODE 1N 4007 GEGURTET	diode 1N 4002
D0310	304360	DIODE 1N 4007 GEGURTET	diode 1N 4002
D0313	301254	DIODE 1N 4148 AXIAL	diode 1N 4148
D0503	354004	LED GN 3MM LOW CURRENT	led green
D0504	354003	LED RT 3MM LOW CURRENT	led red
D0505	354003	LED RT 3MM LOW CURRENT	led red
D0506	354005	LED GE 3MM LOW CURRENT	led yellow
D0509	301254	DIODE 1N 4148 AXIAL	diode 1N 4148
D0510	354004	LED GN 3MM LOW CURRENT	led green
E0001	356594	RELAIS 793-P-1A-S-TV10	relay 24V / spst
E0002	348634	RELAIS 832A-1C-F-C-B 24V DC	relay 24v
F0001	302582	SICHER T 1.000 A/250V	fuse 1A slow blow
F0002	302582	SICHER T 1.000 A/250V	fuse 1A slow blow
F0005	302579	SICHER T 500 MA/250V	fuse 500mA slow blow
F0006	302579	SICHER T 500 MA/250V	fuse 500mA slow blow
H0003	343456	DICKS-NETZW. 8PIN 2%	res.network 8x4k7 Ohm
H0004	343456	DICKS-NETZW. 8PIN 2%	res.network 8x4k7 Ohm
H0100	343456	DICKS-NETZW. 8PIN 2%	res.network 8x4k7 Ohm
H0101	343457	DICKS-NETZW. 8PIN 2%	res.network 8x10k Ohm
I0001	332985	IC TL 074 CN	IC TL 074 CN
I0002	327197	IC NE 5532 P 2FACH OP	IC NE 5532 N
I0005	327197	IC NE 5532 P 2FACH OP	IC NE 5532 N
I0100	327197	IC NE 5532 P 2FACH OP	IC NE 5532 N
I0101	307421	IC CA 3080 E OTA	IC CA 3080 E
I0102	332985	IC TL 074 CN	IC TL 074 CN
I0103	354919	IC OP 97 FP	IC OP 97

Pos. Nr. Ref. No.	Best. Nr. Part No.	Bezeichnung	Description
JS001	338835	STECKER-KALTGERÄTE	connector male mains
L0100	348592	FILTERSP. 2.50UH/0.004OHM	coil 2.5uH
Q0001	306928	TRANS BC 560 C	transistor BC 560 C
Q0002	306928	TRANS BC 560 C	transistor BC 560 C
Q0003	306928	TRANS BC 560 C	transistor BC 560 C
Q0004	306928	TRANS BC 560 C	transistor BC 560 C
Q0005	306928	TRANS BC 560 C	transistor BC 560 C
Q0006	348423	TRANS MPSA 92	transistor MPSA 92
Q0007	348423	TRANS MPSA 92	transistor MPSA 92
Q0008	307150	TRANS BC 337-25 TO 92	transistor BC 337-25
Q0009	301184	TRANS BC 550 C	transistor BC 550 B
Q0010	348591	TRANS BC 618 DARL. TO 92	transistor BC 618
00010	338868	TRANS MJE 340	transistor MJE 340
Q0012	307150	TRANS BC 337-25 TO 92	transistor BC 337-25
00010	338868	TRANS MJE 340	transistor MJE 340
00010	338868	TRANS MJE 340	transistor MJE 340
00010	338869	TRANS MJE 350	transistor MJE 350
00010	338868	TRANS MJE 340	transistor MJE 340
Q0017	307150	TRANS BC 337-25 TO 92	transistor BC 337-25
Q0018	307430	TRANS BC 327-25 TO 92	transistor BC 327-25
Q0019	307430	TRANS BC 327-25 TO 92	transistor BC 327-25
Q0020	301235	TRANS BD 242 B	transistor BD 242 B
Q0021	307150	TRANS BC 337-25 TO 92	transistor BC 337-25
Q0022	301236	TRANS BD 241 B	transistor BD 241 B
Q0023	307150	TRANS BC 337-25 TO 92	transistor BC 337-25
00010	338868	TRANS MJE 340	transistor MJE 340
00010	338869	TRANS MJE 350	transistor MJE 350
Q0100	348421	TRANS 2N 3906	transistor 2N 3906
Q0101	335763	TRANS 2N 3904	transistor 2N 3904
Q0103	330264	TRANS J 111	transistor J 111 A
Q0104	335763	TRANS 2N 3904	transistor 2N 3904
Q0105	348421	TRANS 2N 3906	transistor 2N 3906
Q0106	348422	TRANS MPSA 42	transistor MPSA 42
Q0107	348423	TRANS MPSA 92	transistor MPSA 92
Q0108	335763	TRANS 2N 3904	transistor 2N 3904
Q0109	348421	TRANS 2N 3906	transistor 2N 3906
Q0110	348422	TRANS MPSA 42	transistor MPSA 42
Q0111	348423	TRANS MPSA 92	transistor MPSA 92
Q0112	335763	TRANS 2N 3904	transistor 2N 3904
Q0113	348421	TRANS 2N 3906	transistor 2N 3906
Q0114	335763	TRANS 2N 3904	transistor 2N 3904
Q0115	348421	TRANS 2N 3906	transistor 2N 3906
00010	338869	TRANS MJE 350	transistor MJE 350
00010	338868	TRANS MJE 340	transistor MJE 340
Q0118	348409	TRANS 2SC 4793	transistor 2SC 4793
00010	338869	TRANS MJE 350	transistor MJE 350
00010	338868	TRANS MJE 340	transistor MJE 340
Q0121	348422	TRANS MPSA 42	transistor MPSA 42
Q0122	348423	TRANS MPSA 92	transistor MPSA 92
Q0123	351981	TRANS MJL 3281 A	transistor MJL 3281 A
Q0124	351982	TRANS MJL 1302 A	transistor MJL 1302 A
Q0125	328889	TRANS MJ 15003	transistor MJ 15003
Q0126	328890	TRANS MJ 15004	transistor MJ 15004

Pos. Nr. Ref. No.	Best. Nr. Part No.	Bezeichnung	Description
Q0127	328889	TRANS MJ 15003	transistor MJ 15003
Q0128	328890	TRANS MJ 15004	transistor MJ 15004
Q0129	328889	TRANS MJ 15003	transistor MJ 15003
Q0130	328890	TRANS MJ 15004	transistor MJ 15004
Q0131	328889	TRANS MJ 15003	transistor MJ 15003
Q0132	328890	TRANS MJ 15004	transistor MJ 15004
Q0133	328889	TRANS MJ 15003	transistor MJ 15003
Q0134	328890	TRANS MJ 15004	transistor MJ 15004
Q0135	348422	TRANS MPSA 42	transistor MPSA 42
Q0136	348423	TRANS MPSA 92	transistor MPSA 92
Q0137	348423	TRANS MPSA 92	transistor MPSA 92
Q0138	348422	TRANS MPSA 42	transistor MPSA 42
Q0139	307911	TRANS BF 393	transistor BF 391
Q0140	307911	TRANS BF 393	transistor BF 391
Q0141	348423	TRANS MPSA 92	transistor MPSA 92
Q0142	348423	TRANS MPSA 92	transistor MPSA 92
Q0143	348421	TRANS 2N 3906	transistor 2N 3906
Q0144	348421	TRANS 2N 3906	transistor 2N 3906
Q0145	335763	TRANS 2N 3904	transistor 2N 3904
Q0146	306928	TRANS BC 560 C	transistor BC 560 C
Q0300	348421	TRANS 2N 3906	transistor 2N 3906
Q0314	335763	TRANS 2N 3904	transistor 2N 3904
Q0315	348421	TRANS 2N 3906	transistor 2N 3906
00010	338869	TRANS MJE 350	transistor MJE 350
00010	338868	TRANS MJE 340	transistor MJE 340
Q0318	348409	TRANS 2SC 4793	transistor 2SC 4793
Q0323	351981	TRANS MJL 3281 A	transistor MJL 3281 A
Q0324	351982	TRANS MJL 1302 A	transistor MJL 1302 A
Q0325	328889	TRANS MJ 15003	transistor MJ 15003
Q0326	328890	TRANS MJ 15004	transistor MJ 15004
Q0327	328889	TRANS MJ 15003	transistor MJ 15003
Q0328	328890	TRANS MJ 15004	transistor MJ 15004
Q0329	328889	TRANS MJ 15003	transistor MJ 15003
Q0330	328890	TRANS MJ 15004	transistor MJ 15004
Q0331	328889	TRANS MJ 15003	transistor MJ 15003
Q0332	328890	TRANS MJ 15004	transistor MJ 15004
Q0333	328889	TRANS MJ 15003	transistor MJ 15003
Q0334	328890	TRANS MJ 15004	transistor MJ 15004
00010	338869	TRANS MJE 350	transistor MJE 350
00010	338869	TRANS MJE 350	transistor MJE 350
Q0338	348422	TRANS MPSA 42	transistor MPSA 42
Q0340	348422	TRANS MPSA 42	transistor MPSA 42
00010	338869	TRANS MJE 350	transistor MJE 350
Q0501	306928	TRANS BC 560 C	transistor BC 560 C
Q0502	348422	TRANS MPSA 42	transistor MPSA 42
Q0506	306928	TRANS BC 560 C	transistor BC 560 C
Q0507	306928	TRANS BC 560 C	transistor BC 560 C
R0037	348490	WI-SO NTC K 164/100K/J	safety component NTC
R0065	348550	WI-SO NTC 10 OHM K	safety resistor 10 Ohm
R0185	348456	WI-DR 2X 0.22 OHM 5.00W 5%	resistor 2x0.22 Ohm 5watt
R0188	348456	WI-DR 2X 0.22 OHM 5.00W 5%	resistor 2x0.22 Ohm 5watt
R0191	348456	WI-DR 2X 0.22 OHM 5.00W 5%	resistor 2x0.22 Ohm 5watt
R0194	348456	WI-DR 2X 0.22 OHM 5.00W 5%	resistor 2x0.22 Ohm 5watt

Pos. Nr. Ref. No.	Best. Nr. Part No.	Bezeichnung	Description
R0197	348456	WI-DR 2X 0.22 OHM 5.00W 5%	resistor 2x0.22 Ohm 5watt
R0208	348593	WI-SO NTC K 164/2.2K	safety component NTC
R0209	348593	WI-SO NTC K 164/2.2K	safety component NTC
R0223	348590	WI-DR 8.20 OHM 4.00W 5%	resistor 8.20 Ohm 4watt
R0224	348590	WI-DR 8.20 OHM 4.00W 5%	resistor 8.20 Ohm 4watt
R0225	348590	WI-DR 8.20 OHM 4.00W 5%	resistor 8.20 Ohm 4watt
R0226	348590	WI-DR 8.20 OHM 4.00W 5%	resistor 8.20 Ohm 4watt
R0227	348590	WI-DR 8.20 OHM 4.00W 5%	resistor 8.20 Ohm 4watt
R0241	348590	WI-DR 8.20 OHM 4.00W 5%	resistor 8.20 Ohm 4watt
R0385	348456	WI-DR 2X 0.22 OHM 5.00W 5%	resistor 2x0.22 Ohm 5watt
R0388	348456	WI-DR 2X 0.22 OHM 5.00W 5%	resistor 2x0.22 Ohm 5watt
R0391	348456	WI-DR 2X 0.22 OHM 5.00W 5%	resistor 2x0.22 Ohm 5watt
R0394	348456	WI-DR 2X 0.22 OHM 5.00W 5%	resistor 2x0.22 Ohm 5watt
R0397	348456	WI-DR 2X 0.22 OHM 5.00W 5%	resistor 2x0.22 Ohm 5watt
S0002	338886	SCHALTER-SCHIEBE L202-02-1-	switch slide
VR001	348675	WI-TRI 2.50 KOHM LIN	pot trim 2.5k Ohm lin
VR100	348486	WI-TRI 47.00 KOHM LIN	pot trim 47k Ohm lin
VR101	348674	WI-TRI 250.00 OHM LIN	pot trim 250 Ohm lin
VR301	348674	WI-TRI 250.00 OHM LIN	pot trim 250 Ohm lin
00030	303576	SICHER-HALTE-FEDER	fuse clip
00031	303576	SICHER-HALTE-FEDER	fuse clip
00080	328390	SICHER-HALTER FAU	fuse holder
00085	328391	SICHER-HALTER-KAPPE FEK	fuse holder carrier

# MEMO