

EMERSON RADIO & PHONOGRAPH CORP.

Voltage rating 105 to 125 volts, a.c. or d.c.
 Power consumption 43 watts.
 Frequency ranges 540 to 1700 kc and 2300 to 6600 kc. (Model CG)
 540 to 1700 kc and 2250 to 7500 kc. (Model CY)

MODELS CG268, CG270, CG272
 CG276, CG318 Chassis CG
 CY269, CY271, CY273, CY286
 CY288, CY319 Chassis CY
 Schematics, Voltage

Octal-base tubes in this receiver may be replaced with either metal or bantam-type octal-base glass tubes. The letters "GT" at the end of the tube number indicates that the tube has a bantam glass envelope. In all other respects it is the same as the metal tube bearing the same number without the "GT."

- 1—6A8GT pentagrid oscillator-modulator.
- 1—6K7GT first i-f amplifier.
- †1—6SQ7GT diode detector, a-f amplifier, a.v.c. (see note).
- 1—25L6GT beam power output.
- 1—25Z6GT dual half-wave rectifier.

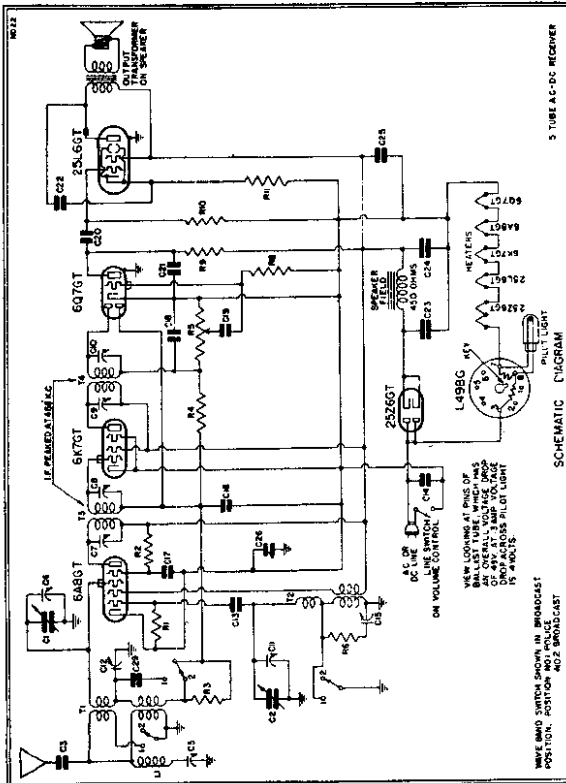

SCHMATIC DIAGRAM No. 22 FOR MODEL CG

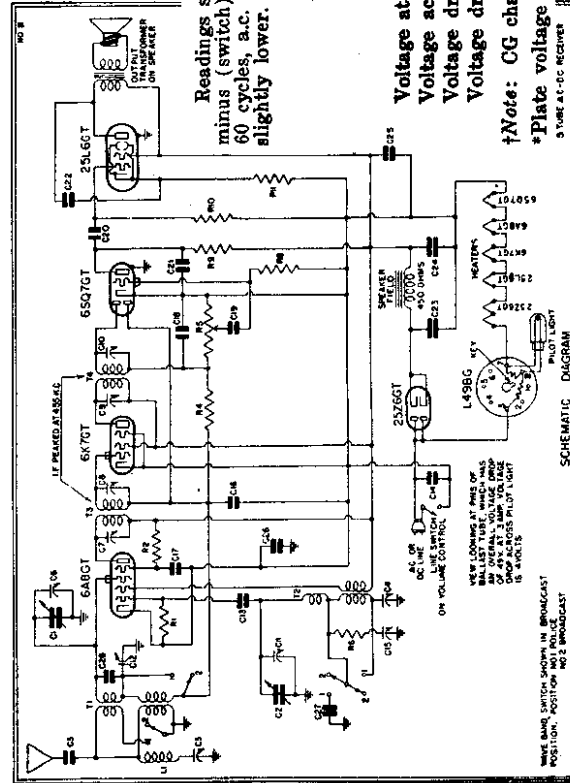

SCHMATIC DIAGRAM No. 21 FOR MODELS CY-269, 271 AND 273 AND 319

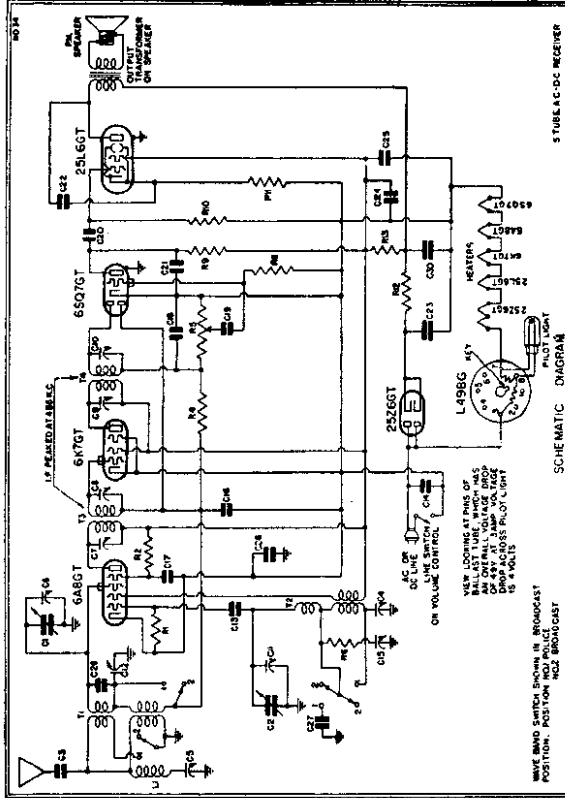

SCHMATIC DIAGRAM No. 84 FOR MODELS CY-286 AND 288

VOLTAGE ANALYSIS

Readings should be taken with a 1000 ohms-per-volt meter. Voltages listed below are from point indicated to B minus (switch) with the volume control turned on full and no signal. Line voltage for these readings was 117.5 volts, 60 cycles, a.c. All readings except cathodes and heaters were taken on 250 volt scale. Readings taken on d.c. will be slightly lower.

Tube	Plate	Screen	Cathode	Osc. Plate	Fil.
6A8GT	95	45	0	95	6.3
6K7GT	95	95	0	—	6.3
†6SQ7GT	88	—	0	—	6.3
‡25L6GT	90	95	6.5	—	25.0

Voltage at 25Z6 cathode—125 volts.
 Voltage across speaker field—28 volts.
 Voltage drop across ballast resistor (pins nos. 3, 7)—49 volts.
 Voltage drop across pilot light section of ballast resistor (pins nos. 8 and 7)—4 volts.

†Note: CG chassis bearing serial numbers below 2,616,849 use 6Q7GT.
 *Plate voltage of 25L6 tube in CY-286 and 288 measures 112 volts.
 The color coding of the i-f transformer leads is as follows:
 Grid—green
 Grid return—black
 Plate—blue
 B plus—red