

SERVICE MANUAL

expert

FD-710

Stereo Cassette Deck

SPECIFICATIONS

Track System	4-track 2-channel, stereo recording and playback
Tape Speed	1-7/8 i.p.s. (4.75 cm/sec.)
Wow and Flutter	0.07% (WRMS)
Frequency Response	30–16,000Hz (±3dB)/ 20–17,000Hz (FeCr tape) 30–16,000Hz (±3dB)/ 20–17,000Hz (CrO ₂ tape) 30–14,000Hz (±3dB)/ 20–15,000Hz (Normal tape) (Dolby NR off)
Signal-to-Noise Ratio	53dB (Dolby NR off, CrO ₂ or FeCr tape, CCIR/ARM weighted 1kHz) The S/N is improved by 9dB with Dolby NR on.
Total Harmonic Distortion	1.8% (at 1kHz, 0dB)
Erase Ratio	65dB (at 400Hz, +10dB)
Bias Frequency	85kHz
Fast Forward and Rewind Time	70 seconds (C-60 tape)

Input Sensitivity/ Impedance	
MIC	0.25mV/12 kohms
LINE	70mV/25 kohms
DIN	2mV/10 kohms
Output Level	
LINE	350mV
HEADPHONES	750mV

GENERAL

Power Consumption	40 watts
Power Supply	
Power Supply	110/220V AC, 50/60Hz
Dimensions	442(W) x 354(D) x 133(H) mm
Weight (Net)	7.2kg (15.9 lbs.)
Accessory	Shielded Audio Cables (2).

- * DOLBY NR
- Dolby NR under license from Dolby Laboratories.
 - The word "DOLBY" and Double-D-Symbol are trademarks of Dolby Laboratories.

Specifications and design are subject to change without notice.

ALIGNMENT PROCEDURE

1) Head Azimuth

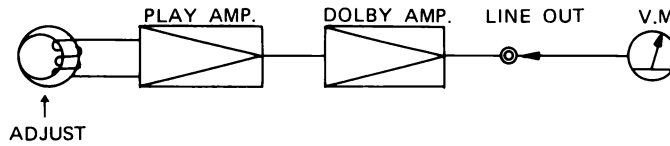

Controls to be positioned	Test Tape	Procedure
Dolby NR : OFF Equalizer : 120 s Function : PLAY Rec. Volume : Max. Balance Volume : Center	MTT-114	1) Adjust the head screw in order to obtain max. V.M. indication.

2) VU Meter

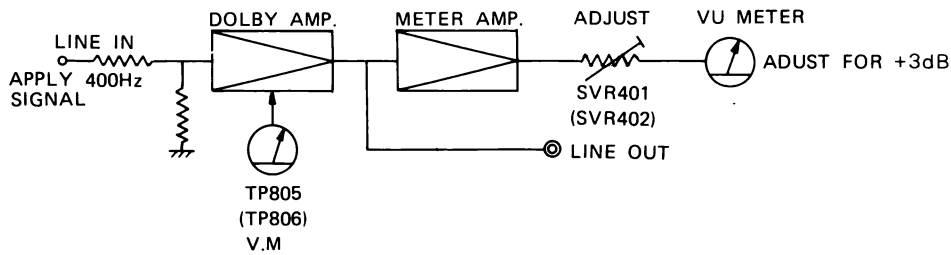

Controls to be positioned	Test Tape	Procedure
Dolby NR : OFF Equalizer : 120 s Function : REC.	Blank Normal	1) Apply 400Hz, 250mV signal at the LINE IN terminal. 2) Adjust REC. and BALANCE volume to have 580mV V.M. indication. 3) Set blank tape, then press the REC. button. 4) Set the VU meter indication to DOLBY LEVEL (double D mark position) with SVR401, 402.

3) Play Back Level

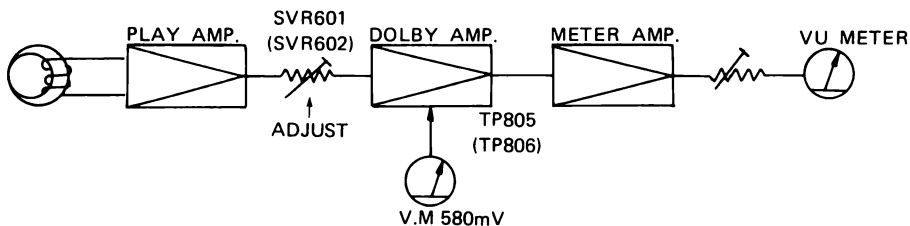

Controls to be positioned	Test Tape	Procedure
Dolby NR : OFF Equalizer : 120 s Function : PLAY	MTT-150	1) Set the V.M. indication to 580mV with SVR601, 602 alignment.

ALIGNMENT PROCEDURE

4) Bias Trap / Bias Voltage

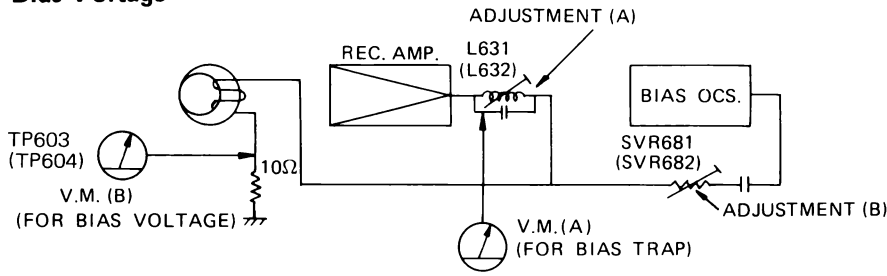

ADJUSTMENT (A) (BIAS TRAP)			
Controls to be positioned		Test Tape	Procedure
Dolby NR	: OFF	Blank	Adjusting L631, 632 to min. indication on the V.M. scale at the Test point of TP601 and 602.
Equalizer	: 70 s	Normal	
Function	: REC.		
Tape Mode	: CrO ₂		
ADJUSTMENT (B) (BIAS VOLTAGE)			
Dolby NR	: OFF	Blank	1) Adjust the bias voltages as follows.
Equalizer	: 120 s	Normal	
Tape Mode	: Normal		
	↓ CrO ₂		
	↓ FeCr		
Step	Tape Mode	Voltage	Adjust
1	Normal	3.7mV	SVR681 SVR682
2	CrO ₂	5.5mV	SVR684
3	FeCr	4.2mV	SVR683

NOTE: Test tapes that required for the above alignment are all TEAC brand and please do not carry out these alignment without test tapes.

All uneven number of Test points and Carbon trimmers aligns for the LEFT channel, and the other numbers aligns for the RIGHT channel.

ALIGNMENT COMPONENT LAYOUT

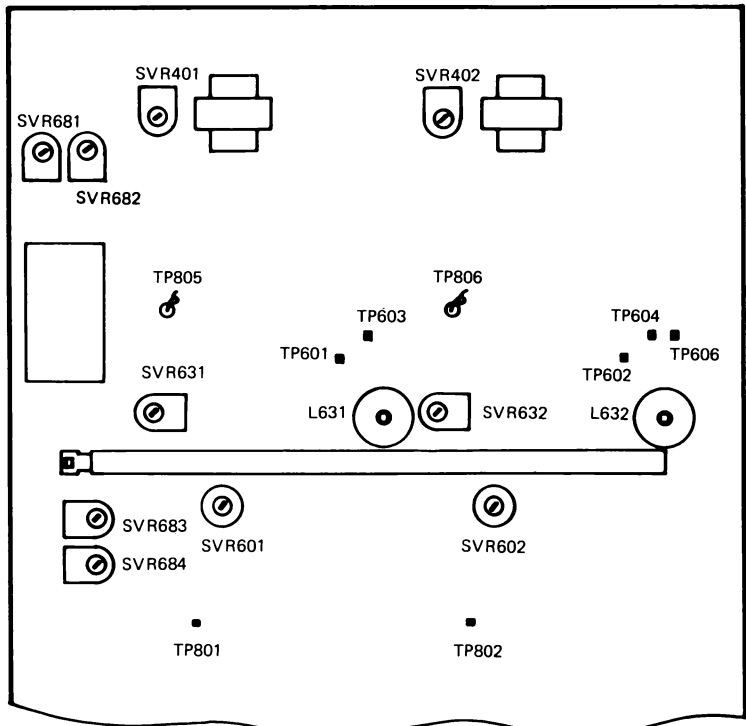

EQ: DOLBY NR, REC, AMP (DAM-166A)

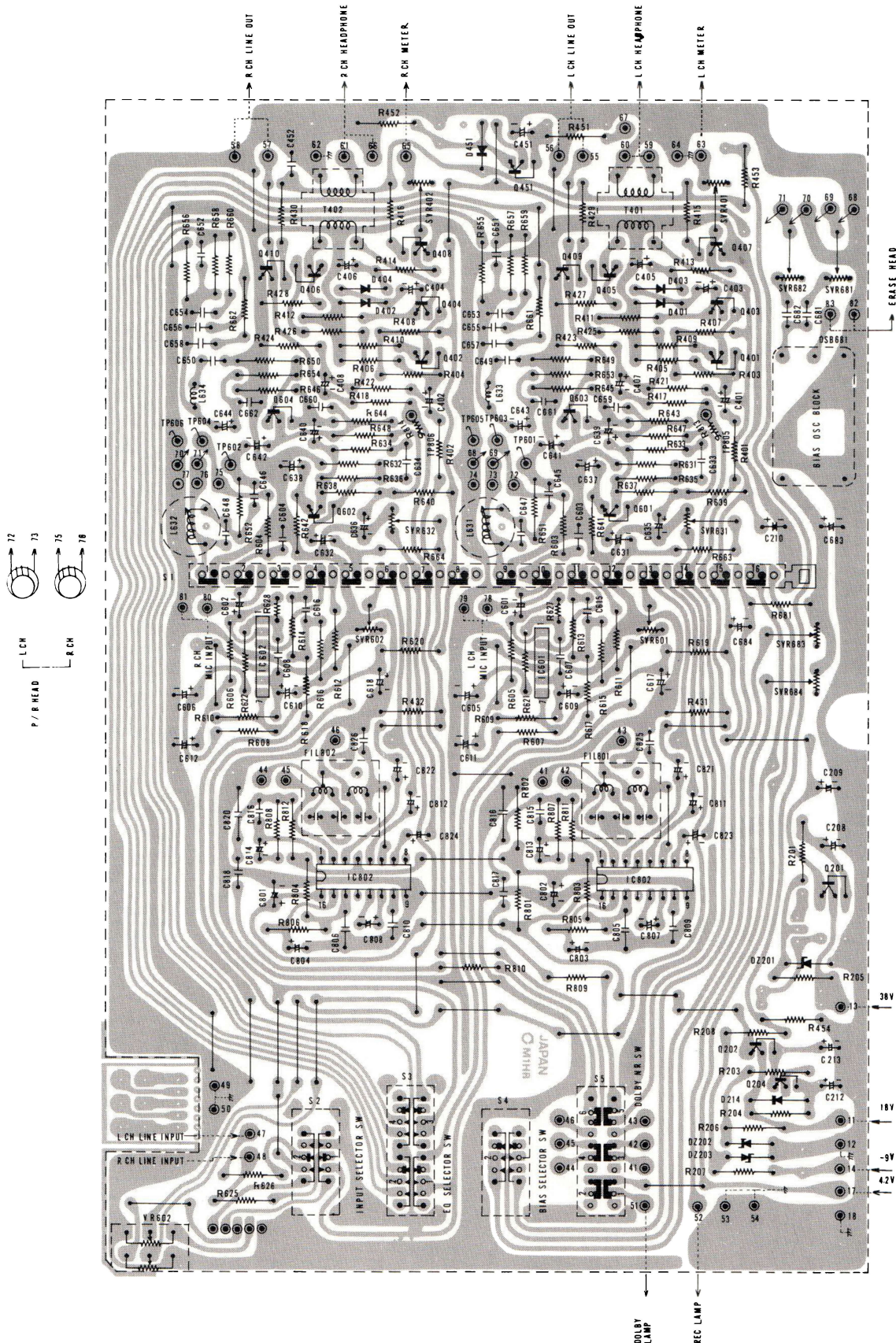

LOGIC CONTROL (DLC-138-1B)

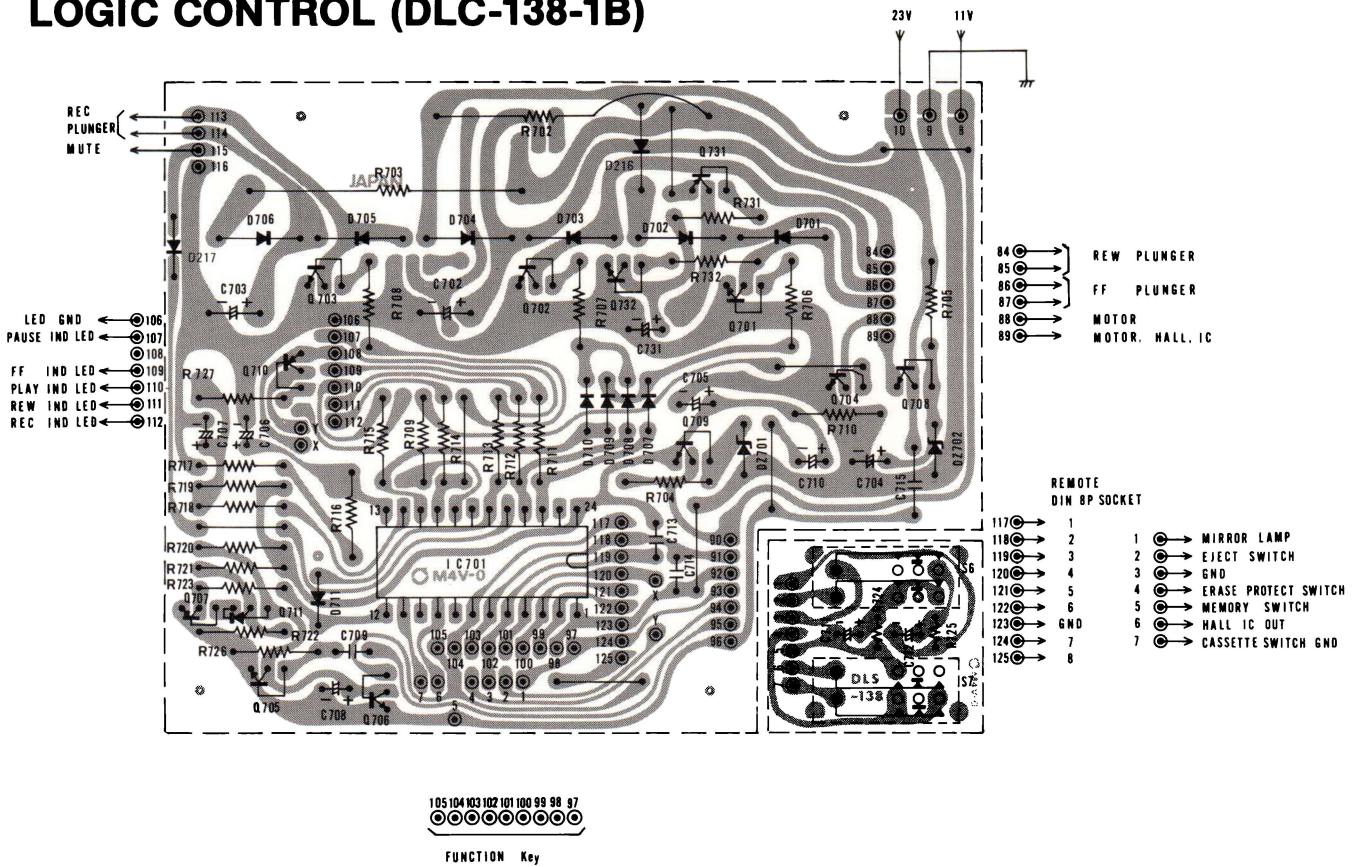

POWER SUPPLY (DPS-183-1)

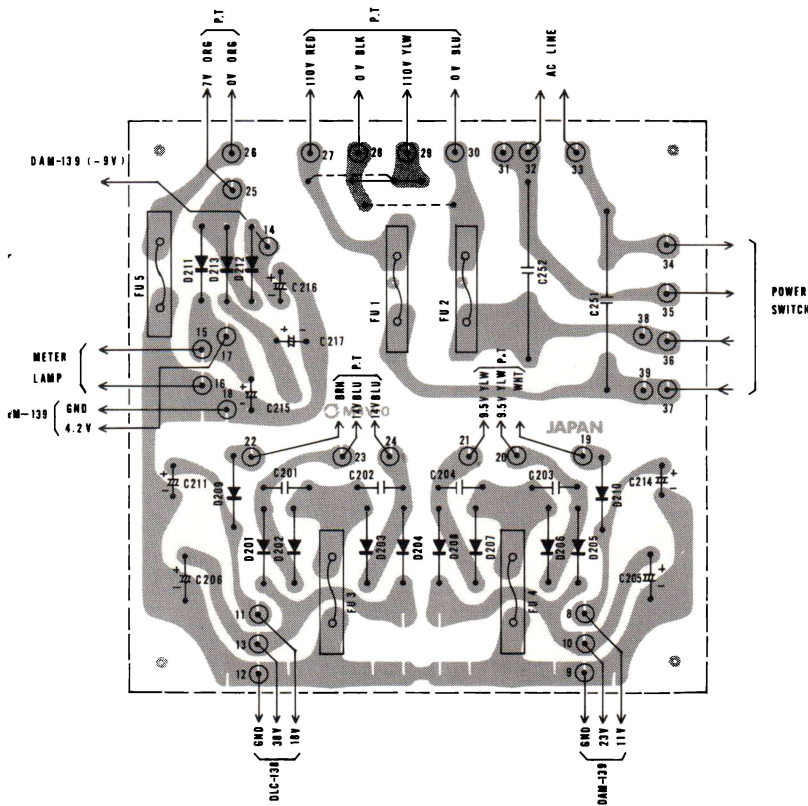

(DDA-167A)

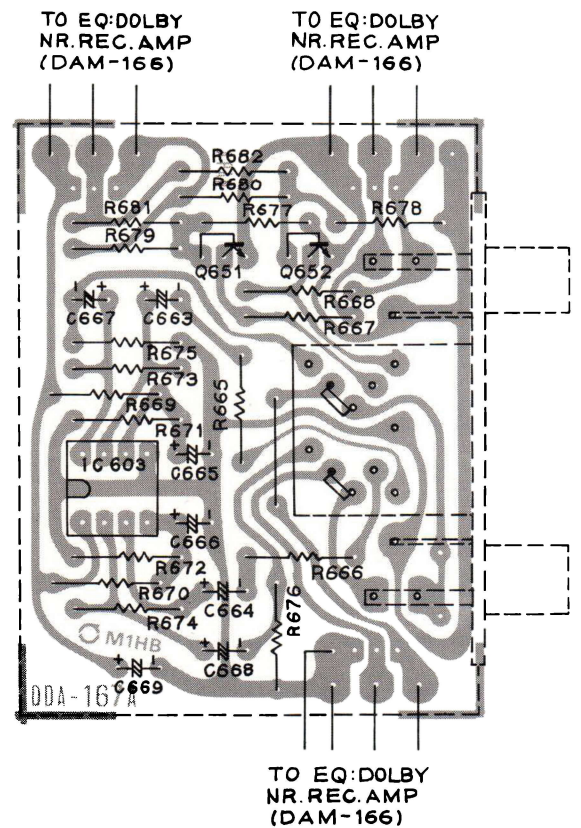

PARTS LIST

Part No.	Description	Symbol No.	Q'ty a set
INTEGRATED CIRCUIT & TRANSISTORS			
TC9121P	LSI	IC701	1
TA7122AP or TA7122BP	IC	IC601, 602	2
μPC4558	IC	IC603	1
NE646BN	IC	IC801, 802	2
2SA564(QR)	Transistor	Q710	1
2SA963(QR)	Transistor	Q731, 733, 735	3
2SC828(QR)	Transistor	Q204, 401, 402, 403, 404, 405, 406, 407, 408, 409, 410, 451, 601, 602, 603, 604, 651, 652, 705, 706, 707, 713, 721, 722, 732, 734, 736	27
2SC1383(QR)	Transistor	Q202, 704, 709	3
2SC2209(QR)	Transistor	Q201, 701, 702, 703	4
2SD592ANC(QR)	Transistor	Q708	1
N13T1	P.U.T.	Q711	1
DIODES			
1S188FM or 1N60 or 20A90	Germanium Diode	D401, 402, 403, 404	4
1S1555 or MA150	Silicon Diode	D451, 707, 708, 709, 710, 711, 721, 722	8
W03B or 1N4002	Silicon Diode	D201, 202, 203 204, 209, 211, 212, 213, 214, 701, 702, 703, 704, 705, 706	15
1N4002	Silicon Diode	D210, 216, 217	3
GP-15B	Silicon Diode	D205, 206, 207, 208	4
HZ6-3-A	Zener Diode	DZ203	1
HZ9-2-B	Zener Diode	DZ701	1
HZ12-3-C	Zener Diode	DZ202, 702	1
HZ24-3	Zener Diode	DZ201	1
GL-9PR2	LED	LED701, 702, 703, 704, 705	5
CONTROLS			
EWK-HWA332A24	Potentiometer	VR601	1
EWK-G4A323703	Potentiometer	VR602	1
EVT R4A00B24	Carbon Trimmer	SVR601, 602	2
2K(B), 8φ	Carbon Trimmer	SVR684	1
5K(B)	Carbon Trimmer	SVR401, 402, 683	3
10K(B)	Carbon Trimmer	SVR631, 632	2
100K(B)	Carbon Trimmer	SVR681, 682	2
SWITCHES			
ESD-81541	Slide Switch	S1	1
SW4235012	Lever Switch	S2, 4	2
SW4435013	Lever Switch	S3	1
SW4635021	Lever Switch	S5	1
ESL-2428	Lever Switch	S6, 7	2
LSA-1139	Leaf Switch	S12	1
HKW0141-01-010	Function Button	S11	1
ESB7097	Unit Ass'y AC ON/OFF Switch	S13	1
BIAS OSC. UNIT			
53T-003 or 191004	Bias OSC. Unit	OSB681	1
FILTER			
12A-1120	Filter, 19kHz	FIL801, 802	2

Part No.	Description	Symbol No.	Q'ty a set
COILS & TRANSFORMERS			
NPT-0435S	Power Transformer		1
162005	Output Transformer	T401, 402	2
1.8mH (MC129Y)	Variable Inductor	L631, 632	2
1.2mH (RC-875)	Inductor	L633, 634	2
CONNECTORS & TERMINALS			
HLJ-0294-01-02	Headphone Jack		1
HLJ-0264-01-03	Mic Jack		2
CS728-1-2	8 Hole DIN Socket		1
N41572	4-Pin Jack		1
MC03-021	Micro Connector Ass'y	3-Pin	1
MC06-014	Micro Connector Ass'y	6-Pin	1
MC07-015	Micro Connector Ass'y	7-Pin	1
MC07-016	Micro Connector Ass'y	7-Pin	1
MC09-017	Micro Connector Ass'y	9-Pin	1
MC09-018	Micro Connector Ass'y	9-Pin	1
171825-3	Micro Plug, 3-Pin		1
171825-6	Micro Plug, 6-Pin		1
171825-7	Micro Plug, 7-Pin		2
171825-9	Micro Plug, 9-Pin		1
SR3P-4	Strain Relief, Line Cord		1
PC-002	Audio Cable		2
ACC-010	Line Cord		1
PRINTED CIRCUIT BOARD			
D.A. M-139	Amplifier P.C.B.		1
D.L. C-138	Logic Control P.C.B.		1
D.L. S-138-1	Logic Switch P.C.B.		1
D.P. S-140	Power Supply P.C.B.		1
SOLENOID			
180005	Solenoid	SL3	1
FUSES, METERS & LAMPS			
FU-520201-5T	Fuse (200mA)	FU1, 2	2
FU-520202-5T	Fuse (2A)	FU5	1
FU-523152-5T	Fuse (3.15A)	FU6, 7	2
FU-520501-5T	Fuse (500mA)	FU8, 9	2
KL-258T-6	Level Meter (Silver)	LA903, 904	2
BQ044-23633A	Lamp	LA901, 902	2
BQ141-26404A	Lamp, Meter	LA903, 904	2
PL12303003A	Lamp	LA905	1
FUSE HOLDERS			
S-N5053	Fuse Holder		14
RESISTORS			
¼W 3.3KΩ	Metal Film Resistor	R811, 812	2
7W 39Ω	Wire-Wound Resistor	R702, 703	2
CAPACITORS			
20pF	Ceramic Capacitor	C607, 608, 659, 660	4
200pF	Ceramic Capacitor	C647, 648, 681, 682	4
270pF	Ceramic Capacitor	C825, 826	2
MC0.01μF	Ceramic Capacitor	C713, 714, 715, 716	4
SC0.05μF	Ceramic Capacitor	C201, 202, 203, 204	4

PARTS LIST

Part No.	Description	Symbol No.	Q'ty a set
ECQ-P 1472FZ	Polypropylene	C815, 816	2
ECQ-P 1562FZ	Polypropylene	C817, 818	2
ECQ-P 1273FZ	Polypropylene	C819, 820	2
560pF	Polystyrene	C603, 604, 645, 646	4
ECNC4A 103M	Oil	C251, 252	2
50V 0.0012μF	Mylar (±5%)	C645, 646	2
50V 0.0068μF	Mylar (±5%)	C615, 616, 649, 650, 656	5
50V 0.0082μF	Mylar (±5%)	C662	1
50V 0.01μF	Mylar (±5%)	C655, 661	2
50V 0.012μF	Mylar (±5%)	C651, 652	2
50V 0.047μF	Mylar (±5%)	C653, 654, 809, 810	4
50V 0.056μF	Mylar (±5%)	C657, 658	2
50V 0.1μF	Mylar (±5%)	C633, 634, 805, 806	4
50V 0.033μF	Mylar (±20%)	C452, 709	2
ECEA50MR33	Electrolytic (0.33M)	C803, 804	2
ECEA50MR47R	Electrolytic (0.47M)	C811, 812	2
ECEA16M10R	Electrolytic (10M)	C601, 602	2
10TW 47μF	Electrolytic	C216	1
10TW 100μF	Electrolytic	C637, 638	2
10TW 220μF	Electrolytic	C215	1
10TW 470μF	Electrolytic	C611, 612, 217	3
10TW 33μF	Electrolytic	C407, 408, 643, 644	4
10TW 1000μF	Electrolytic	C218	1
10TW 2200μF	Electrolytic	C219	1
16TW 4.7μF	Electrolytic	C667, 668	2
16TW 10μF	Electrolytic	C212, 403, 404, 631, 710, 807, 813, 814, 821, 823, 824, 822, 808, 632, 665, 666	16
16TW 47μF	Electrolytic	C704	1
16TW 100μF	Electrolytic	C705	1
16TW 220μF	Electrolytic	C802	1
16TW 1000μF	Electrolytic	C214	1
25TW 3.3μF	Electrolytic	C707	1
25TW 1μF	Electrolytic	C663, 664	2
25TW 4.7μF	Electrolytic	C401, 402, 641, 642	4
25TW 10μF	Electrolytic	C213, 609, 610, 639, 640	5
25TW 47μF	Electrolytic	C208, 605, 606, 635, 636, 669	6
25TW 100μF	Electrolytic	C210, 617, 618, 683, 801	5
25TW 220μF	Electrolytic	C209, 211	2
35TW 220μF	Electrolytic	C250	1
35TW 100μF	Electrolytic	C731, 732, 733	3

Part No.	Description	Symbol No.	Q'ty a set
35TW 1000μF	Electrolytic	C205	1
50TW 0.1μF	Electrolytic	C721	1
50TW 1μF	Electrolytic	C405, 406, 684, 706, 711, 712	6
50TW 2.2μF	Electrolytic	C708	1
50TW 220μF	Electrolytic	C206	1
APPEARANCE PARTS			
N10114	Front Panel		1
N41095	Cass' Window Mtg. Bkt.		1
N20395-BK	Cass' Holder		1
N30252-2	Knob Guide	Timer, Memory Switch	1
N30252-1	Knob Guide	Bias, EQ, Input Switch	4
N30209-1BK	Knob Guide	Dolby NR Switch Power ON/OFF Switch	1
N41232	Side Cap, Right		1
N41233	Side Cap, Left		1
N41281-S	Push Button, Power	Power	1
N41265	Push Button, Eject	Eject	1
N30254A	Knob, Lever		6
N41291	Reset Button		1
N41661	Knob 21	Rec. Balance	1
N41660	Knob 44	Rec. Level	1
N30248-BK	Cass' Compartment		1
N30251-BK1	Meter Plate		1
N41266-BK	Top Cover	Cass' Holder	1
N41293	Alum. Plate	Logic Cont.	1
N41443	Meter Window		1
N41250-T	Cass' Window		1
N41109	Counter Window		1
N20398	Case		1
T-C	Foot		4
MISCELLANEOUS			
N41310	Switch Shaft	Power	1
N41261	Shaft Coupler	Front	1
N41262	Shaft Coupler	Rear	1
N41283A	Eject Spring		1
N41294	Spring A		1
N41295	Spring B		1
N41258	Cass' Holding Spring		1
OM-152	Instruction Book		1
PACKING MATERIAL			
N41318	Poly. Bag	For Unit	1
N40487	Poly. Bag	For Inst. Book	1
N20389	Pad, Right		1
N20390A	Pad, Left		1
N41424	Pad, Top		1
N41662	Carbon		1

- NOTE: 1. Part orders must contain Model Number, Part Number and Description.
 2. Ordering quantity of screws and/or resistors must be multiple of 10 pcs.
 3. Resistors not detailed in parts list are all carbon type ¼ watt, with regard to the value, refer to the schematic diagram.

PARTS LIST CASSETTE DECK MODEL CT-3309B

Parts No.	Description	Q'ty
A0170	Drive Arm Ass'y	1
A0180	Reel Ass'y SA	1
A0190	Reel Ass'y TA	1
A02000	Drive Pulley Ass'y	1
A0230	Soft Dumper Ass'y	1
C0390	Counter	1
E1360	S, K Binder	1
E1310	Hall Generator	1
F0130	Fly wheel M	1
G0430	Erase Head	1
G1340	R/P Head	1
G1350	Motor	1
J0100	Pinch Roller	1
J0280	Rew. Idler A	1
J0440	Pinch Roller Arm	1
J0460	Shaft Supporter G	1
J0640	Cass' Guide LA	1
J0650	Cass' Guide RA	1
J0670	Pulley (For String)	1
K1630	FF Idler Arm Ass'y	1
K1640	FF Action Arm Ass'y	1
K1660	Action Plate Ass'y	1
K2090	Chassis Ass'y	1
K2100	Head Panel Ass'y	1
K2360	Sub Chassis B	1
K2440	FF Lever Ass'y A	1
P0130	Solenoid Ass'y	2
Q0240	R/P Head Spring B	1
Q1990	Pinch Roller Spring	1
Q2010	FF Action Arm Spring	1
Q2020	Rew. Arm Spring A	1
Q2050	Brake Arm Spring RA	1
Q2060	Brake Arm Spring LA	1
Q2080	Action Plate Spring	1
Q2100	Drive Arm Spring	1
Q2110	Action Lever Spring	1
Q2140	Action Lever Spring	1
Q2150	Action Plate Spring	1
Q2260	Erase Head Spring	1
Q2310	Back Tension Spring	1
S0340	Micro Switch SS-5GL13	1
T0210	String Ass'y	1
T0220	Rec. Sensor Ass'y A	2
U0170	Counter Belt	1
U0340	Rubber Cushion	3
U0600	Adjusting Screw *	1
U0840	Brake L	1
U0850	Brake R	1
U0860	Rubber (For Brake)	2
U0890	Reel Cap C	2
U1080	Drive Belt	1
U1300	Rubber Cushion C	2
U1310	Main Belt	1
U1500	Felt 1x6x4	1
V2910	Collar 2.8x3.5x5	1

Parts No.	Description	Q'ty
V3210	FF Idler Arm Collar	1
V3960	Case Lock Arm Collar	1
V4470	Motor Pulley	1
X1920	Lug E	3
X4110	Washer	1
X4580	Pressing Metal	1
X4910	Action Arm Bracket A	1
X4970	Action Arm A	1
X4980	Head Panel Pushing Plate G	1
X5040	Rew. Arm	1
X6330	Head Panel Pushing Plate J	1
X6340	Flywheel Supporter Q	1
X6350	Micro Switch Bracket	2
X6370	Cass' Hold Back Spring Plate	1
X6380	Head Panel Pushing Plate K	1
X6390	Solenoid Arm Guide A	1
X6400	Solenoid Arm RB	1
X6410	Solenoid Arm LB	1
X6460	Motor Holder R	1
X6570	IC Board Bracket A	1
X7140	Rew Lever	1
X7160	Lock Bracket B	1
X7180	Back Tension Brake C	1
X7210	Drive Arm Pushing Plate A	1
X7220	Supporting Plate For Brake A	2
01105	Screw 2.3x4	2
01111	Screw 2.3x10	2
01144	Screw 2.6x3	6
01151	Screw 2.6x10	2
01166	Screw 3x5	2
04085	Screw 2x4	1
17165	Screw 3x5	1
18086	Bind Screw 2x5	1
18088	Bind Screw 2x7	1
19145	Screw W/Spring Washer 2.6x4	1
19146	Screw W/Spring Washer 2.6x5	14
19149	Screw W/Spring Washer 2.6x8	2
19155	Screw W/Spring Washer 2.6x14	1
19166	Screw W/Spring Washer 3x5	4
20148	Screw W/Flat Washer 2.6x7	3
21046	Screw W/Flat Washer 2.6x4.5	2
21050	Screw W/Flat Washer 2.6x6.5	1
23007	Tapping Screw 2.6x6	3
23014	Tapping Screw 2.6x5	5
27026	Spring Washer M2.6	2
30126	Flat Washer 2.8x7.5x0.5	2
32201	P.S.W 2.1x4x0.13	1
32252	P.S.W 2.6x4.7x0.25	4
33077	Spring Pin 3x16	2
35104	Rivet 2x3	2
36015	E Ring E-1.5	2
36020	E Ring E-2.0	6
36025	E Ring E-2.5	2
42025	Steel Ball M2.5	6

EXPLODED DIAGRAM

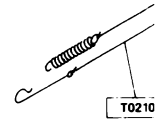

X6530

X6520

01144

30126

19146

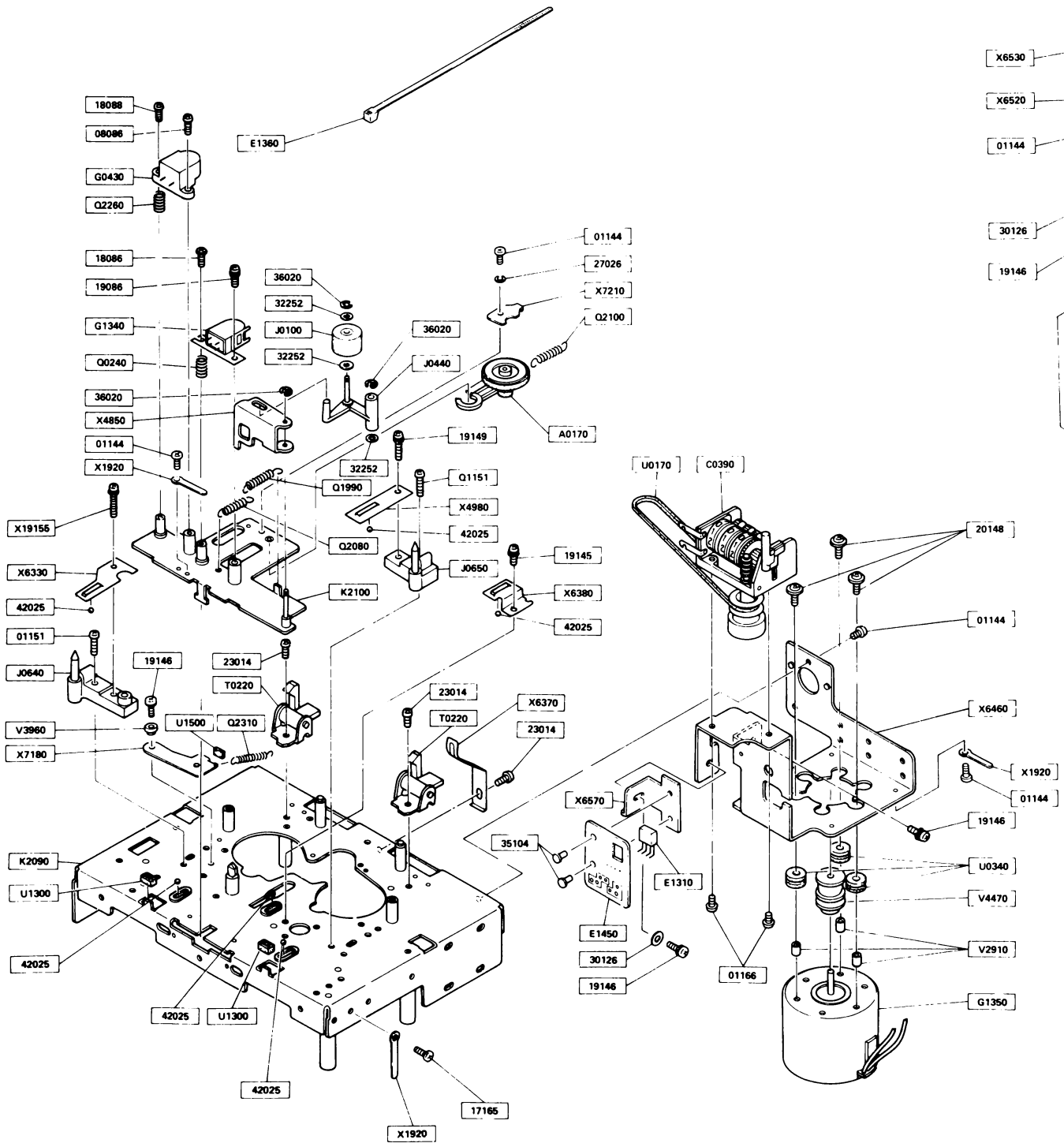

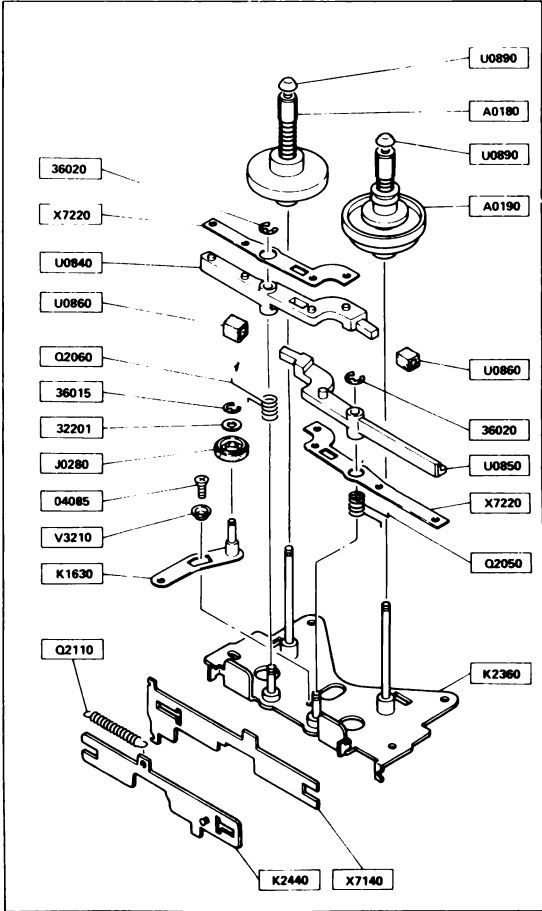
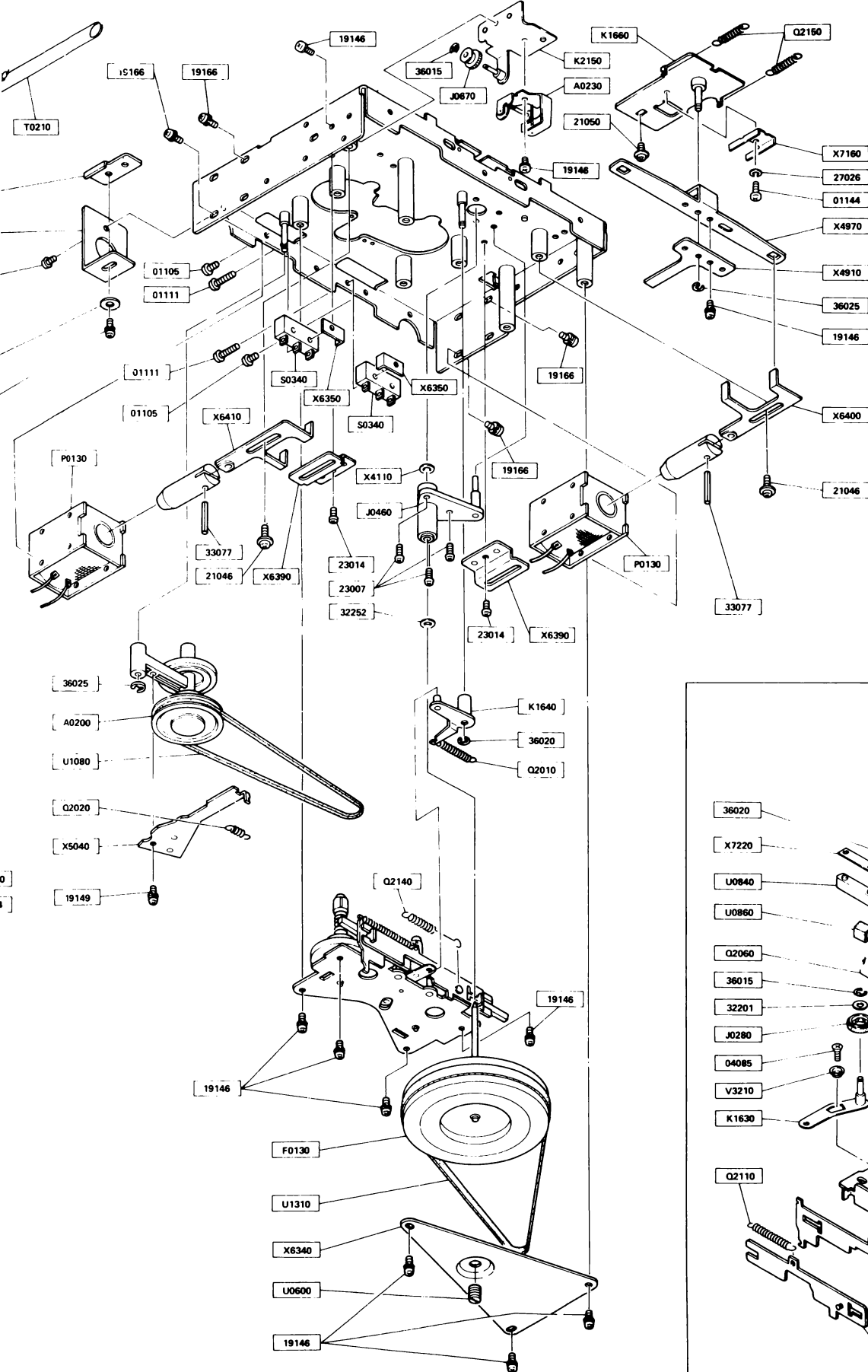

CIRCUIT DIAGRAM

LOGIC CONTROL BOARD (DLC-138B)

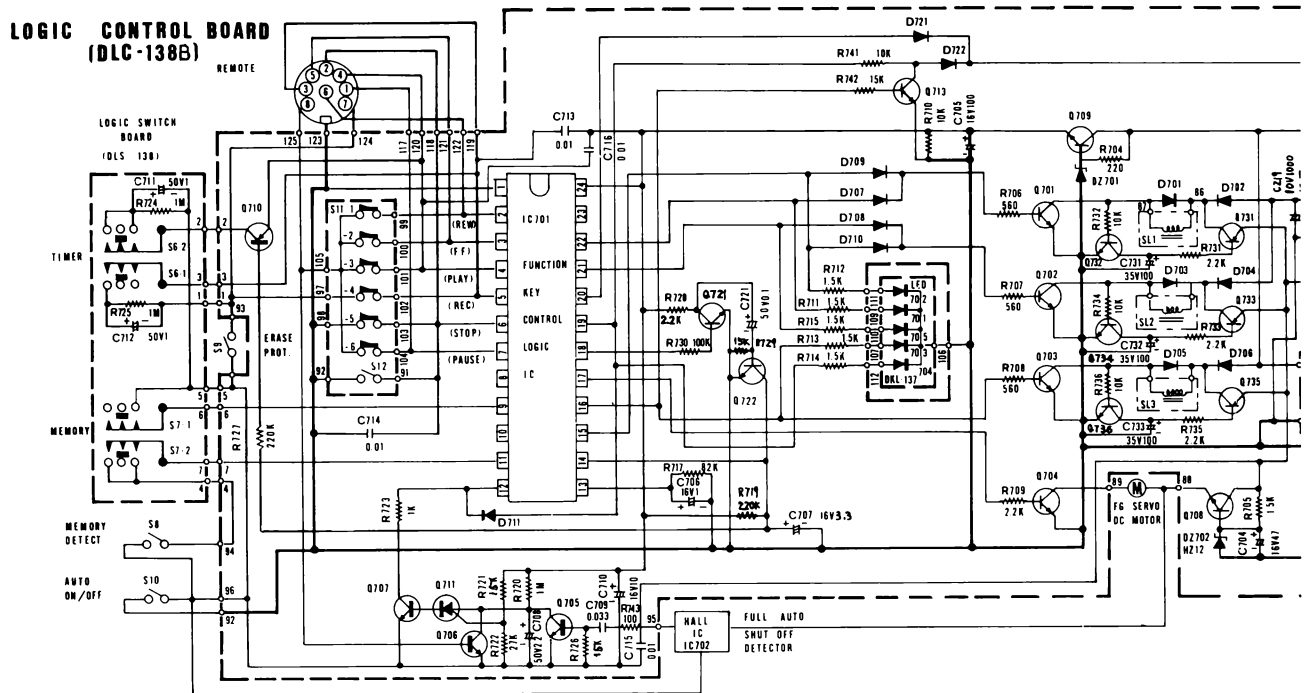

DIN AMP P.C. BOARD DDA-176

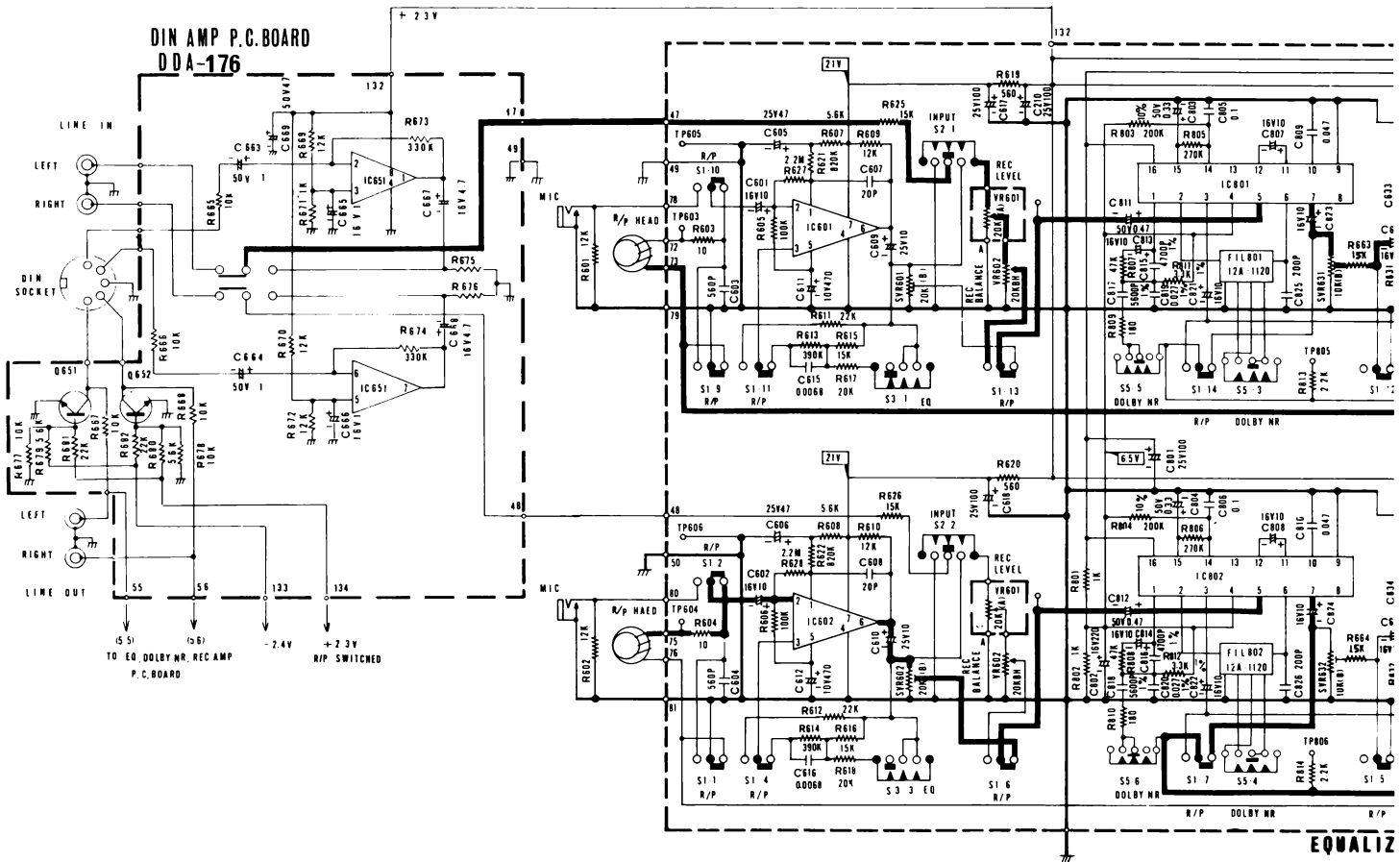

POWER SUPPLY BOARD (DPS-183)

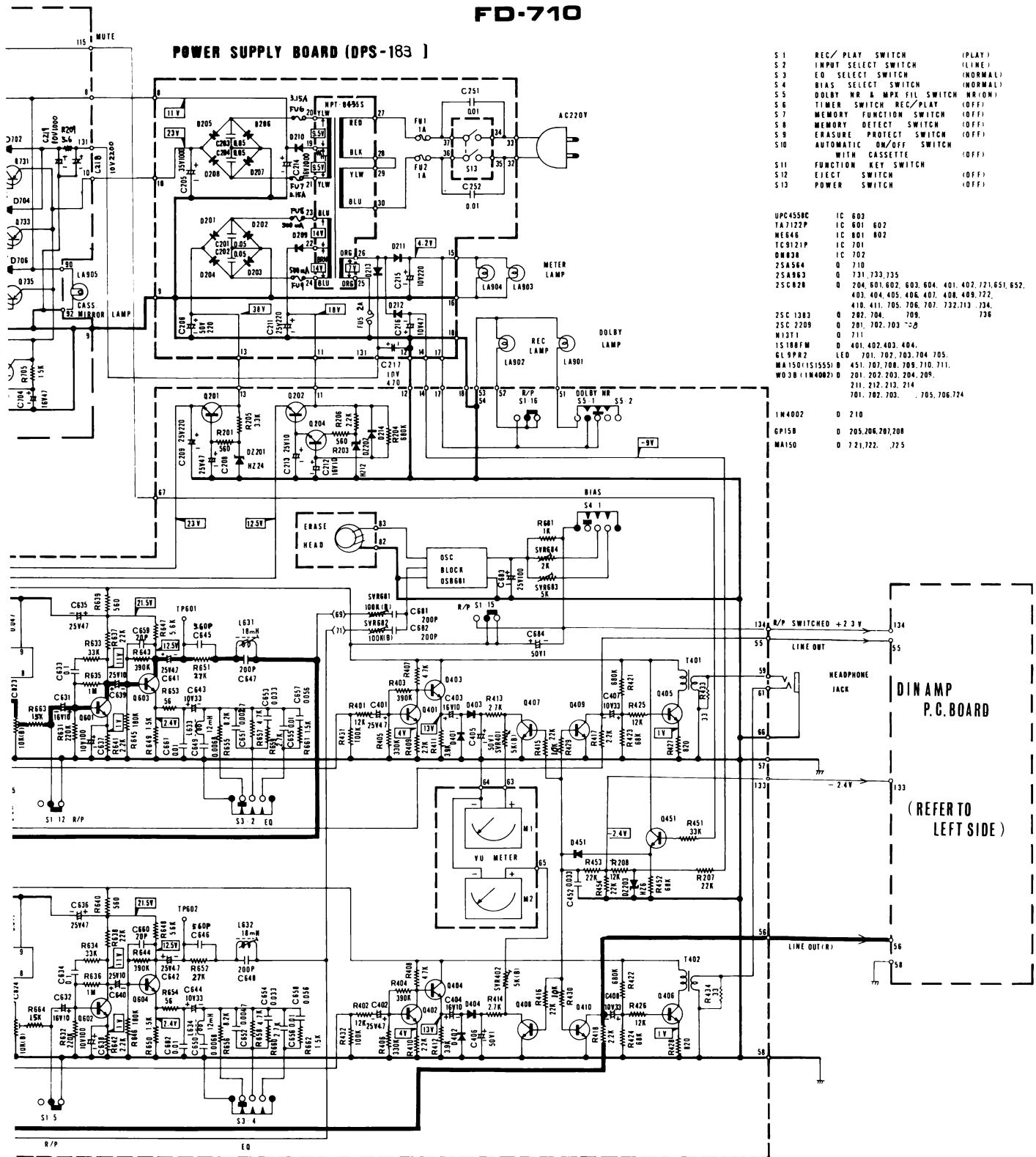

- S 1 REC/ PLAY SWITCH (PLAY)
- S 2 INPUT SELECT SWITCH (LINE)
- S 3 EQ SELECT SWITCH (NORMAL)
- S 4 BIAS SELECT SWITCH (NORMAL)
- S 5 DOLBY NR & MPX FILL SWITCH (NR/ON)
- S 6 TIMER SWITCH REC/PLAY (OFF)
- S 7 MEMORY FUNCTION SWITCH (OFF)
- S 8 MEMORY DETECT SWITCH (OFF)
- S 9 ERASURE PROTECT SWITCH (OFF)
- S 10 AUTOMATIC ON/OFF SWITCH (OFF)
- S 11 WITH CASSETTE (OFF)
- S 12 FUNCTION KEY SWITCH (OFF)
- S 13 EJECT SWITCH (OFF)
- S 13 POWER SWITCH (OFF)

- UPC4558C IC 603
- TA7122P IC 601 602
- WE44 IC 801 802
- TC9121P IC 701
- DM38 IC 702
- 2SA564 Q 710
- 2SA963 Q 731, 733, 735
- 2SC828 Q 204, 601, 602, 603, 604, 401, 402, 721, 651, 652, 403, 404, 405, 406, 407, 408, 409, 722, 410, 411, 705, 706, 707, 732, 713, 734, 736
- 25C 1383 Q 202, 704, 708
- 25C 2209 Q 201, 702, 703, 709
- 1N131 Q 711
- 15188FM D 401, 402, 403, 404
- 6L59PR LED 701, 702, 703, 704, 705
- MA1501S1555 D 451, 707, 708, 710, 711
- W03B (1N4002) D 201, 202, 203, 204, 205, 211, 212, 213, 214, 701, 702, 703, 705, 706, 724
- 1M4002 D 210
- 6P158 D 205, 206, 207, 208
- MA150 D 721, 722, 725

DIN AMP P.C. BOARD

(REFER TO LEFT SIDE)

EQUALIZER, DOLBY, REC AMP BOARD (DAM-166)

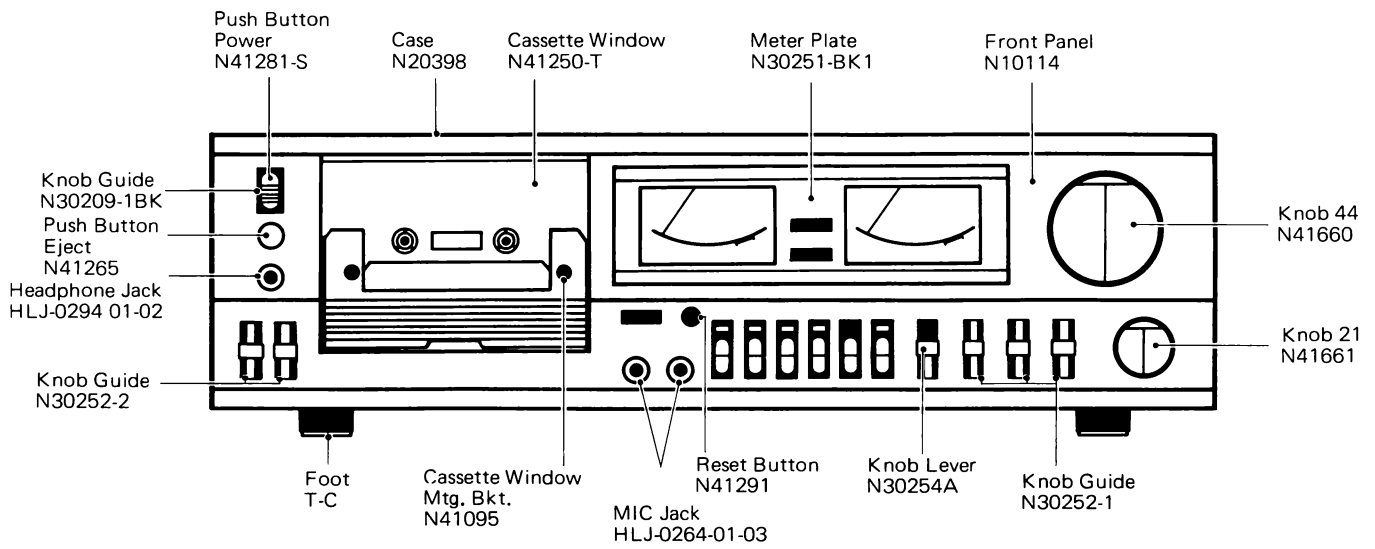

BLOCK DIAGRAM

