

REVISIONS			
REV.	DESCRIPTION	DATE	APPROVED
A	PR626	18-MAY-05	E M M

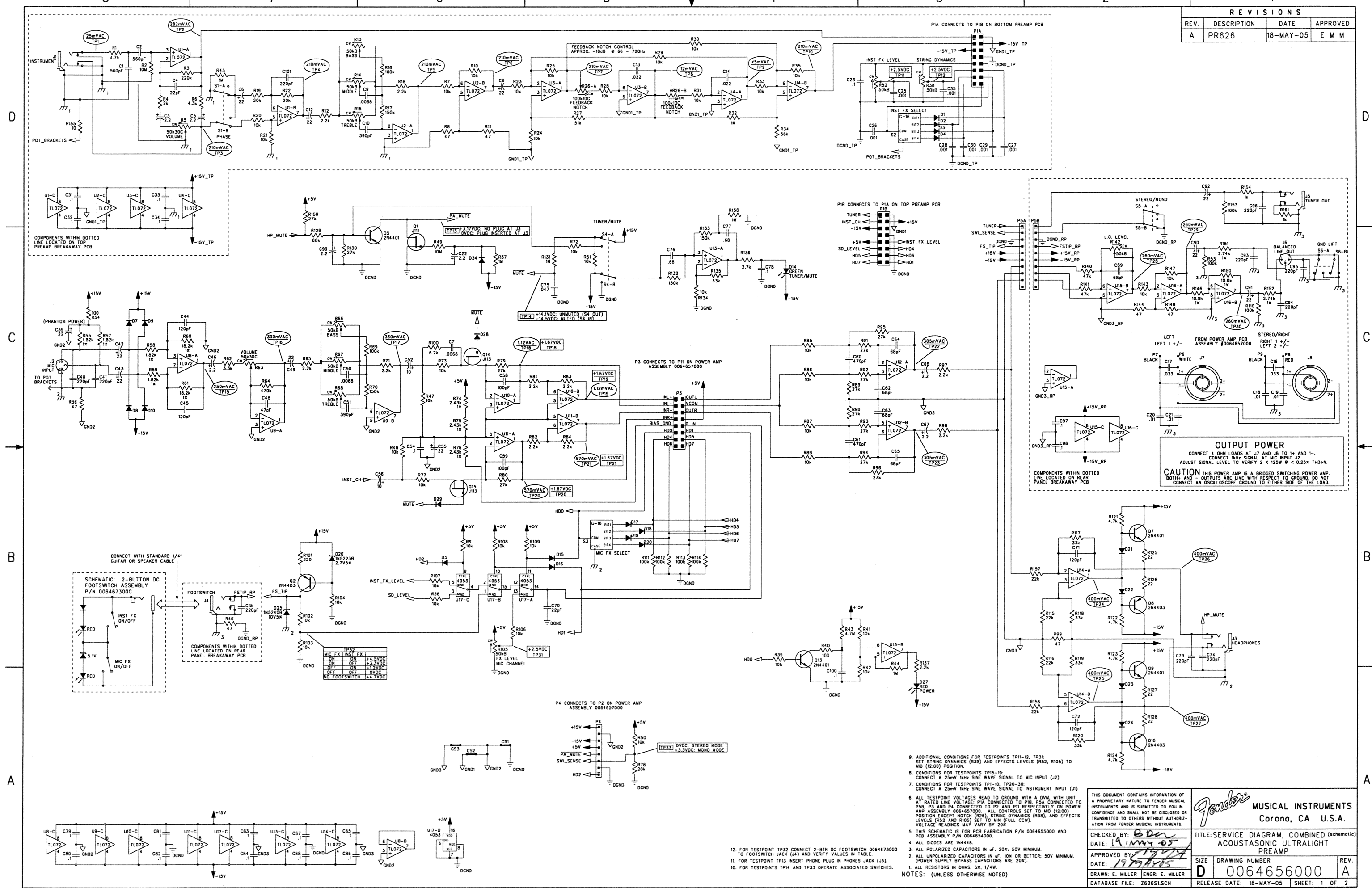

- ADDITIONAL CONDITIONS FOR TESTPOINTS TP11-12, TP31: SET STRING DYNAMICS (R38) AND EFFECTS LEVELS (R52, R105) TO MID (12:00) POSITION.
- CONDITIONS FOR TESTPOINTS TP15-19: CONNECT A 25mV 1kHz SINE WAVE SIGNAL TO MIC INPUT (J2)
- CONDITIONS FOR TESTPOINTS TP1-10, TP20-30: CONNECT A 25mV 1kHz SINE WAVE SIGNAL TO INSTRUMENT INPUT (J1)
- ALL TESTPOINT VOLTAGES READ TO GROUND WITH A DVM, WITH UNIT AT RATED LINE VOLTAGE; P1A CONNECTED TO P1B, P3A CONNECTED TO P3B, P3 AND P4 CONNECTED TO P2 AND P11 RESPECTIVELY ON POWER AMP ASSEMBLY 0064657000. ALL CONTROLS SET TO MID (12:00) POSITION EXCEPT NOTCH (R26), STRING DYNAMICS (R38), AND EFFECTS LEVELS (R52 AND R105) SET TO MIN (FULL CCW). VOLTAGE READINGS MAY VARY BY 20%.
- THIS SCHEMATIC IS FOR PCB FABRICATION P/N 0064655000 AND PCB ASSEMBLY P/N 0064654000.
- ALL DIODES ARE 1N4448.
- ALL POLARIZED CAPACITORS IN μ F, 20K; 50V MINIMUM.
- ALL UNPOLARIZED CAPACITORS IN μ F, 10K OR BETTER; 50V MINIMUM. (POWER SUPPLY BYPASS CAPACITORS ARE 20K).
- ALL RESISTORS IN OHMS, 5K; 1/4W.
- FOR TESTPOINT TP32 CONNECT 2-BUTTON DC FOOTSWITCH 0064673000 TO FOOTSWITCH JACK (J4) AND VERIFY VALUES IN TABLE.
- FOR TESTPOINT TP13 INSERT PHONE PLUG IN PHONES JACK (J3).
- FOR TESTPOINTS TP14 AND TP33 OPERATE ASSOCIATED SWITCHES.

THIS DOCUMENT CONTAINS INFORMATION OF A PROPRIETARY NATURE TO FENDER MUSICAL INSTRUMENTS AND IS SUBMITTED TO YOU IN CONFIDENCE AND SHALL NOT BE DISCLOSED OR TRANSMITTED TO OTHERS WITHOUT AUTHORIZATION FROM FENDER MUSICAL INSTRUMENTS.

Fender MUSICAL INSTRUMENTS
Corona, CA U.S.A.

CHECKED BY: *B. Dan*
DATE: *19 MAY 05*

APPROVED BY: *[Signature]*
DATE: *19 MAY 05*

DRAWN: E. MILLER ENGR: E. MILLER
DATABASE FILE: Z62651SCH

TITLE: SERVICE DIAGRAM, COMBINED (schematic) ACOUSTASONIC ULTRALIGHT PREAMP

SIZE: **D** DRAWING NUMBER: **0064656000** REV: **A**

RELEASE DATE: 18-MAY-05 SHEET: 1 OF 2

8 | 7 | 6 | 5 | 4 | 3 | 2 | 1

REVISIONS			
REV.	DESCRIPTION	DATE	APPROVED
A	PR 626	18-MAY-05	E M M

D
C
B
A

D
C
B
A

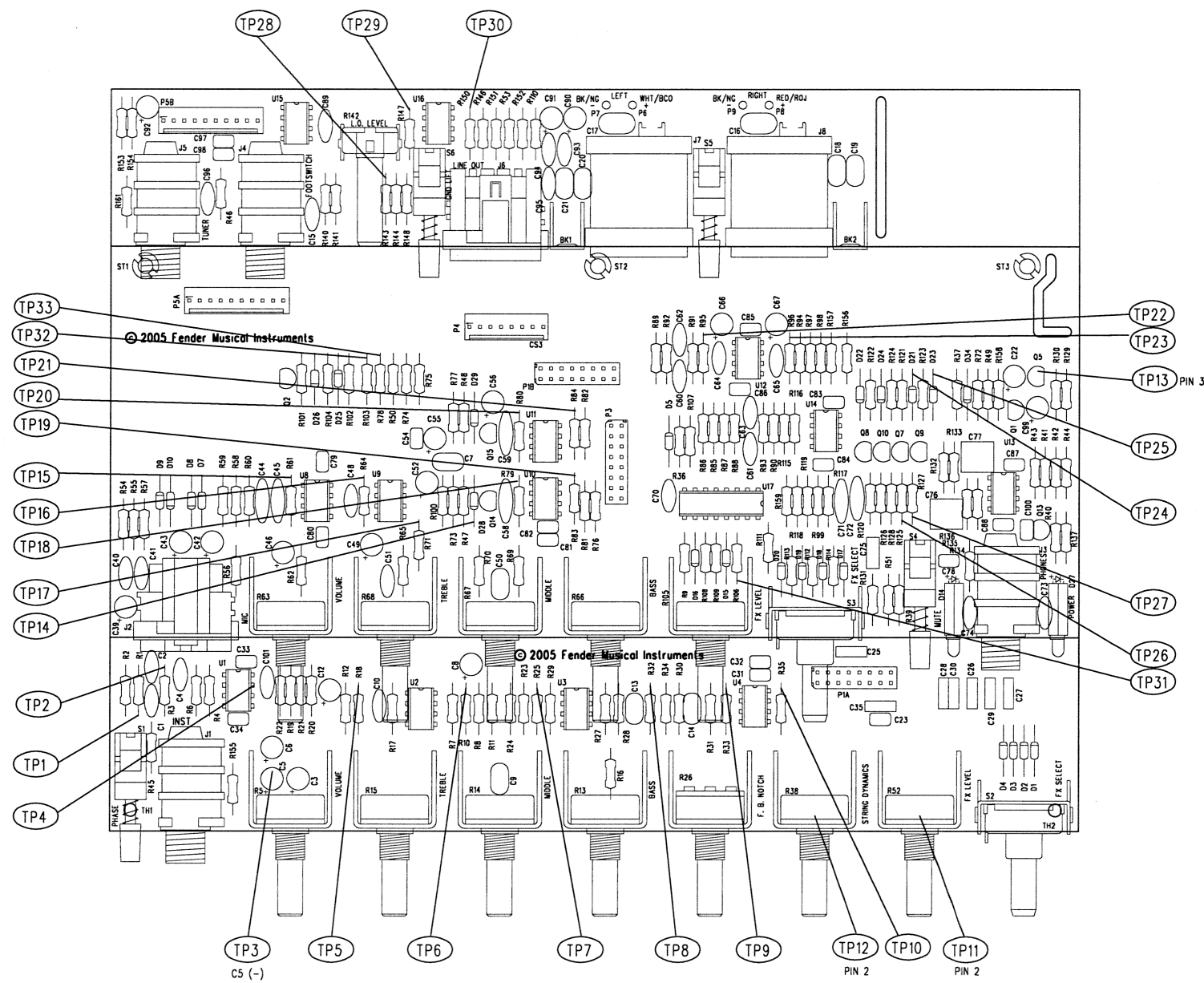

FILM/DWG: SERVICE DIAGRAM
 DATABASE: Z626P1.PCB DATE: 18-MAY-05

1. SEE SHEET 1 FOR TEST CONDITIONS AND TP VALUES.
 NOTES: (UNLESS OTHERWISE NOTED)

THIS DOCUMENT CONTAINS INFORMATION OF A PROPRIETARY NATURE TO FENDER MUSICAL INSTRUMENTS AND IS SUBMITTED TO YOU IN CONFIDENCE AND SHALL NOT BE DISCLOSED OR TRANSMITTED TO OTHERS WITHOUT AUTHORIZATION FROM FENDER MUSICAL INSTRUMENTS.		 MUSICAL INSTRUMENTS Corona, CA U.S.A.	
CHECKED BY: <i>EMM</i> DATE: <i>19-MAY-05</i>		TITLE: SERVICE DIAGRAM, COMBINED (PCB assy) ACOUSTASONIC ULTRALIGHT PREAMP	
APPROVED BY: <i>EMM</i> DATE: <i>18-MAY-05</i>		SIZE: C	DRAWING NUMBER: 0064656000
DRAWN: E MILLER	ENGR: E MILLER	RELEASE DATE: 18-MAY-05	REV. A
DATABASE FILE: Z626P1.PCB		SHEET 2 OF 2	

8 | 7 | 6 | 5 | 4 | 3 | 2 | 1