



'63 Fender Reverb

REISSUE SERIES

SERVICE MANUAL



Fender Musical Instruments Corp.
7975 North Hayden Road Scottsdale, AZ 85258

'63 Fender Reverb
(This is the model name for warranty claims)
SERVICE MANUAL

JUNE 1994 REV A
TYPE PR 263

IMPORTANT NOTICE:

The information contained herein is CONFIDENTIAL and PROPRIETARY to Fender Musical Instruments Corp. It is disclosed solely for use by qualified technicians for purposes of equipment maintenance and service. It is not to be disclosed to others without the expressed permission of Fender Musical Instruments Co. All specifications subject to change without notice.

For warranty repair service, only Fender specified part numbers are to be used. It is recommended they also be used for post-warranty maintenance and repair.

Parts marked with an asterisk (*) indicate the required use of that specific part. This is necessary for RELIABILITY and SAFETY requirements. **DO NOT USE A SUBSTITUTE!**

A coded naming convention is used in the description of certain parts. The codes and what they mean are as follows:

CAPACITOR CODES

CAP AE = Aluminum Electrolytic
CAP CA = Ceramic Axial
CAP CD = Ceramic Disk
CAP MPF = Metalized Polyester Film
CAP MY = Mylar
CAP PFF = Polyester Film/Foil

RESISTOR CODES

RES CC = Carbon Comp
RES CF = Carbon Film
RES FP = Flame Proof
RES MF = Metal Film
RES WW = Wire Wound

HARDWARE CODES

BLX = Black Oxide
CR = Chrome Plated
HWH = Hex Washer Head
M = Machine Screw
NI = Nickel Plated
OHP = Oval Head Phillips
PB = Particle Board
PHP = Pan Head Phillips
PHPS = Pan Head Phillips Sems
SMA = Sheet Metal "A" Point
SMB = Sheet Metal "B" Point
SS = Stainless Steel
TF = Thread Forming
ZI = Zinc Plated

'63 Fender Reverb

THEORY OF OPERATION

The input jack contains a Tip Shunt switch contact which will ground the input when the plug is removed.

The input impedance consists of R1R11 and R12 in parallel, and equals approx. 500k ohm.

The first stage (V1A) provides a voltage gain of 38.8 ($V_{out}/V_{in} = 1.94V/50mV = 38.8$). Bypass capacitor C2 increases the AC gain, and also reduces hum. The voltage divider R2 and R3 reduce the voltage so the overall gain is about 3. The signal then feeds the Dwell control, which determines the amount of signal sent to the reverb drive circuit.

V1B provides a voltage gain of 20. C3 and R9 make up a single pole filter which provides 6db per octave of low frequency roll off at 300Hz. Excessive low frequencies can make the reverb sound unnatural and boomy.

V2 is a 6V6GT power tube which supplies voltage and current gain to drive the reverb transformer. Due to the lack of availability, the original 6K6 power tube was replaced with a modern 6V6. CR7 (56V Zener) protects C4 from exploding if V2 develops an internal short. This is necessary to conform to modern day NEMKO safety requirements.

The footswitch turns the reverb on and off by grounding the input to the reverb recovery circuit. R13 provides a ground reference (or bias) for the input of V3A. This prevents instability in V3A if the reverb recovery cable is disconnected from the reverb pan. V3A senses the reverb return signal and amplifies it with a gain of about 37.

The Tone control (R17) attenuates the high frequencies above 3kHz, through C9. C10 provides a slight bass roll off which is affected by the position of the Mix control in relation to the input impedance of the guitar amplifier.

V3B is a cathode follower, unity gain buffer amplifier for the dry signal.

C11 is a non-polarized, metallized polyester film capacitor, which is located across the high voltage transformer secondary, suppresses EMI frequencies from 20kHz to 30mHz. This is necessary to conform to modern day NEMKO safety requirements.

The pot mounting brackets are all connected together via traces on the circuit board. The trace connects to the star audio ground through R22. R22 places 15 ohms of resistance between audio ground and the pot mounting brackets. This is done for two reasons. First, with the circuit board installed, the pot brackets are physically connected to chassis/earth ground. R22 isolates audio ground from earth ground through the pot brackets. This eliminates internal ground loops. Secondly, when the circuit board is removed for repair and testing, R22 provides a ground reference (15 ohms) for the pot brackets. R23 places 15 ohms of resistance between audio ground and chassis/earth ground. This minimizes hum by eliminating ground loops internally and externally when connection with other units. R22 and R23 are Flame Proof/Fusable resistors. If excessive current flows through these resistors, they will not burn, they will simply open.

CR5 & 6 (across R23) provide an important safety feature. If the guitar amp chassis becomes electrified, current will flow through the coax cable to the power supply ground of the Fender Reverb unit. The current will seek earth ground through R23. When R23 opens, the earth ground connection is broken. This will electrify the reverb unit's ground and thus the guitar (ouch!). CR5 & 6 provide an alternate path to earth ground if R23 opens.

'63 Fender Reverb PARTS LIST

NOTE: SHADED ITEMS ARE FOR REFERENCE ONLY

PRINTED CIRCUIT BOARD ASSEMBLY			REFERENCE DESIGNATION
QTY	PART #	DESCRIPTION	
2	037325	CABLE FLAT 6 CKT 2 INCH	
2	024819	CAP AE AX 22uF 500V 20%	C12,13
2	009512	CAP AE AX 22uF 25V 20%	C2,4
1	041589	CAP AE AX 47uF 500V 20%	C14
1	038695	CAP AE 220uF 16V 20%	C7
1	020917	CAP CD 250PF 1000V 10%	C10
2	024823	CAP MPE RDL .01uF 400V 10%	C1,9
2	024845	CAP MPE RDL .017uF 400V 10%	C5
1	024854	CAP MPE RDL .1uF 400V 10%	C5
1	024855	CAP MPE RDL .1uF 630V 10%	C6,8
1	026202	CAP PFF .0022uF 600V	C3
1	047608	CONTROL SNAPIN 50K B TAPER	R17
2	036962	CONTROL SNAPIN 250K B TAPER	R5,18
4	026730	DIODE 1N4006/1N5062 800PRV 1A	CR1,2,3,4
4	029045	DIODE 6A 400V 6A4 LEAD FORMED	CR5,6
1	047206	DIODE ZEN 1N6370V 56V 5W 5%	CR7
14	025802	FSTN TAB MALE 250X.032 PCB MT	CP1,-14
2	037117	JACK PCB MONO CLOSED CKT	J1,2
2	020888	JUMPER WIRE 22GA.5X.175	
1	047596	PCB ASSY 63 TUBE REVERB	(STUFFED)
1	047595	PCB FAB 63 TUBE REVERB	(RAW PCB)
2	031901	PIN MALE PCB .093 DOA	SP1,2
2	033205*	RES M/F FUSE 1/4W 5% 150HM	R22,23
2	026368	RES CF 1/2W 5% 1000HM	R19,20
4	024969	RES CF 1/4W 5% 1.5K	R4,6,8,15
1	024981	RES CF 1/4W 5% 10K	R2
4	025116	RES CF 1/2W 5% 100K	R3,7,14,16
1	025059	RES CF 1/4W 5% 220K	R9
2	025069	RES CF 1/4W 5% 1M	R1,13
2	025075	RES CF 1/4W 5% 2.2M	R11,12
1	027349	RES FILM 1W 5% 10K	R21
1	036921	RES FILM 2W 5% 1K	R10

CHASSIS ASSEMBLY

QTY	PART #	DESCRIPTION	REFERENCE DESIGNATION
2	018022	BUSHING SNAP 5/16X17/32 BLK	
1	026038	BUSHING SR .625X.062X37/64 BLK	(@ POWER CABLE 100/120V)
1	010401	BUSHING SR .625X.125X37/64 WHT	(@ POWER CABLE 230V)
1	026541	CABLE ASSY PWR W/250 TAB 120V	(POWER CABLE 100/120V ONLY)
1	033331	CABLE ASSY PWR 220/240V	(POWER CABLE 230V)
1	047597	CHASSIS 63 REVERB	(RAW CHASSIS)
1	022707	CHIKE FILTER	L1
1	047988	CHS ASSY BROWN 120V 63 TUBE RB	
1	032219	COLLAR-PILOT LIGHT	(THROUGH FRONT PANEL)
1	036702	FUSE HOLDER 3AG FINGER GRIP	XF1 (100V/120V ONLY)
1	036703	FUSE HOLDER 5mm FINGER GRIP	XF1 (230V EXPORT)
1	010036	FUSE TD 1-1/4X1/4 250V 0.5A	F1 (100V/120V ONLY)
1	013109	FUSE TD 20mmX5mm 250V 250MAT	F1 (220V/230V/240V ONLY)
1	021741	HOLDER IDAL LITE ASSY PILOT	(PILOT LAMP SOCKET)
1	021956	JACK PHONE OPEN CIRCUIT 11	J3 (FOOTSWITCH JACK)
2	033329	JACK PHONO 2 CND PNL MT	J4,5 (REVERB JACKS)

**'63 Fender Reverb
CHASSIS ASSEMBLY (CONT)**

QTY	PART #	DESCRIPTION	REFERENCE DESIGNATION
1	025718	JEWEL #20 PILOT LITE	(RED)
3	036678	KNOB VINTAGE DARK BROWN	(BROWN CABINET)
3	041263	KNOB VINTAGE CREAM	(BLACK, BLOND CABINET)
1	031625	NUT HOLDER PILOT LIGHT 1/16-27	
2	022004	NUT KEPS #8-32 ZINC	(POWER XFMR MOUNT)
1	047598	PANEL FRONT 63 TUBE RYRB BROWN	(BROWN, BLOND CABINET)
1	047599	PANEL FRONT 63 TUBE RYRB BLACK	(BLACK CABINET)
1	021642	PILOT LIGHT #T147	
12	031184	SCRW M 6-32X1/4 PHPSBLX	(PCB MOUNT)
2	026553	SCRW M 8-32X3/8 PPHP BLX	(POWER XFMR MOUNT)
12	038900	SCRW TF 6-32X3/8 PHP ZI	
6	031073	STANDOFF 6-32X3/8 RND AL	
1	036570	SWITCH TOGGLE DPST W/ NUTS	(PCB MOUNT)
1	023531	TUBE 12AT7	S1 (POWER SWITCH)
1	023564	TUBE 6V6GTA STR391A	V1
1	013341	TUBE 7025/12AX7	V2
1	020424	TUBE RING UNIVERSAL (277H-2)	V3
2	036598	TUBE SHIELD	(@V2)
1	023580	TUBE SOCKET 8 PIN	(@V1,3)
2	023606	TUBE SOCKET 9 PIN	XV2
2	047950	WASHER FIBER FLAT RCA	SV1,3
2	047949	WASHER FIBER SHOULDER RCA	@J4,5
1	9904300920	WASHER FLAT 482X.709 NI	(@J4,5)
3	027520	WSHR FLAT .380X.630 FIBER	(@ POWER SWITCH)
3	026401	WSHR SHLDR FIB 3/8X5/8	(@J1,2,3)
1	047609	XFMR POWER 120V DOMESTIC	(@J1,2,3)
1	047610	XFMR POWER EXPORT	T1 (120V ONLY)
1	04605	XFMR REVERB DRIVER OUTPUT	T1 (100/110/120/220/230/240V)
			T2

CABINET ASSEMBLY

QTY	PART #	DESCRIPTION	REFERENCE DESIGNATION
1	047606	BRACKET "L" REVERB HOLD DOWN	
1	047591	CAB ASSY 63 REVERB BROWN/TAN	(BROWN CABINET, TAN GRILLE)
1	037003	CAB ASSY 63 REVERB BLOND/OXBLD	(BLOND CABINET, OXBLOOD GRILLE)
1	047590	CAB ASSY 63 REVERB BLACK/SILVER	BLACK CABINET, SILVER GRILLE
1	047625	BACK ASSY 63 REVERB BLACK	(BACKBOARD)
1	047638	BACK ASSY 63 REVERB BLOND	(BACKBOARD)
1	047640	BACK ASSY 63 REVERB BROWN	(BACKBOARD)
1	047816	CABLE REVERB 350MM	
1	047639	GRILLE ASSY 63 REVERB TAN	(USED ON BROWN CABINET)
1	047637	GRILLE ASSY 63 REVERB OXBLOOD	(USED ON BLOND CABINET)
1	047627	GRILLE ASSY 63 REVERB SILVER	(USED ON BLACK CABINET)
1	037790	HANDLE 9.25" BLACK RIBBED	(USED ON BLACK CABINET)
1	036129	HANDLE 9" LEATHER BROWN	(ON BROWN & BLOND CAB)
2	036478	HANDLE CAP NI	(@ HANDLE, BLACK CABINET)
1	036795	NAMEPLATE 62 FENDER	(BROWN, BLOND CABINET)
1	023192	NAMEPLATE FENDER 65 TWIN	(BLACK CABINET)
4	022004	NUT KEPS #8-32 ZINC	(@GRILLE, REVERB MOUNT)
2	025819	NUT KEPS 10-32 ZINC	(CHASSIS MOUNT)
1	047603	PANEL REAR 63 REVERB BRN TEXT	(@ BROWN, BLOND CABINET)
1	048462	PANEL REAR 63 REVERB BLK TEXTXT	(BLACK CABINET)
1	036650	PIN ESCUTCHEON #16X3/8 NI	(PANEL REAR, MOUNT)
1	047604	REVERB UNIT 8 OHM 4AB3C1C VERT	
4	026419	SCRW 8/32X1 PHP STL NI	(LEATHER HANDLE MOUNT)
2	036619	SCRW M 10-32X1-1/2 THP NI	(CHASSIS MOUNT)
2	022244	SCRW M 8-32X-1/2 FHP BLK	(@ GRILLE, REVERB MOUNT)
2	029828	SCRW PB 8X3/4 PHP ZI	(@ HOLD DOWN BRACKET)
8	037952	SCRW SMA #6X1 OHP NI	(GRILLE/BACK MOUNT)
4	037210	SCRW SMA 2X3/8 OHP NI	(62 VINTAGE LOGO MOUNT)
3	037985	SCRW SMA 2X3/8 PHP BLX	(65 LOGO MOUNT)

**'63 Fender Reverb
CABINET ASSEMBLY (CONT)**

QTY	PART #	DESCRIPTION	REFERENCE DESIGNATION
4	047784	SPRING ANCHOR	(SPRING OVER SCREW)
4	047607	SPRING EXTENSION	(FROM ANCHOR TO PAN)
8	037215	WSHR C:SNK #6 NI	(GRILLE/BACK MOUNT)
4	026459	WSHR FLAT 6X3/8 ZI	

FOOTSWITCH ASSEMBLY

QTY	PART #	DESCRIPTION	REFERENCE DESIGNATION
1	048458	FOOTSWITCH 1BTN VINTAGE SHIELD	(COMPLETE FOOTSWITCH)
1	021691	BUSHJUNG SR .500X.100X7/16 BLK	
1	022657	COVER CUP SINGLE FT SW ASSY	
1	028915	PLUG PHONE RTANG SHIELDED	
1	024042	SWITCH SPST PUSH BUTTON	
12ft	023861	WIRE BLACK STRANDED 2 COND PLA	

MISCELLANEOUS

QTY	PART #	DESCRIPTION	REFERENCE DESIGNATION
1	047980	MANUAL OWNERS 63 FENDER REVERB	
1	047593	SCHEM REDUC 63 FENDER REVERB	(WITH SERVICE DIAGRAM)

REVISIONS				
ZONE	REV.	DESCRIPTION	DATE	APPROVED
	A	RELEASED PR# 263	28-JAN-94	PW
	B	ECO LO 2891	25-APR-94	MH

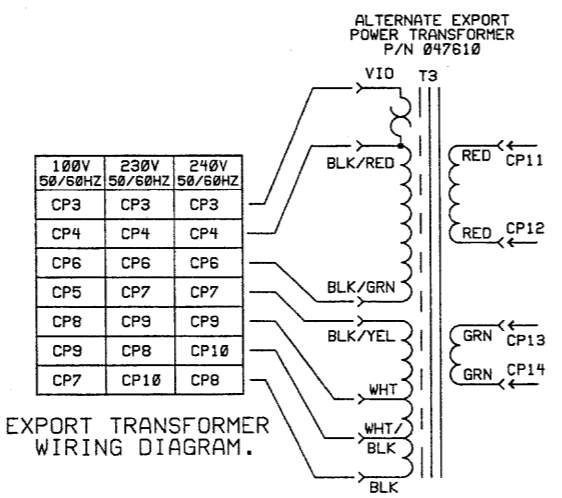
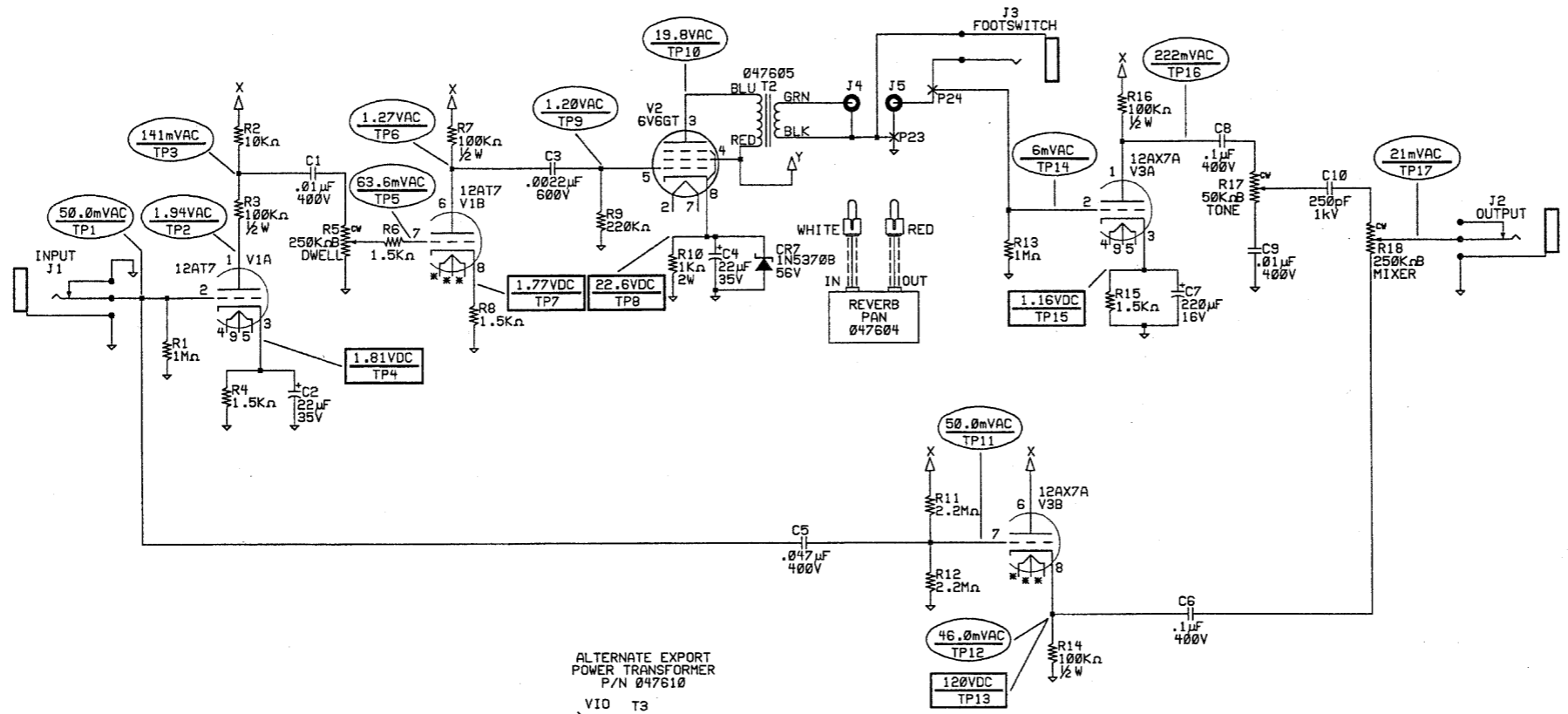

NOTES: (UNLESS OTHERWISE SPECIFIED)

- 1.) ALL RESISTORS 1/4 W.
- 2.) ALL DIODES 1N4006 (1N5062).
- 3.) 6-DIGIT NUMBERS ARE FENDER PART NUMBERS.
- 4.) ALL VOLTAGES MEASURED WITH RESPECT TO GROUND USING A DVM OF AT LEAST 1MΩ AC INPUT IMPEDANCE AND 10MΩ DC INPUT IMPEDANCE. TEST CONDITIONS: LINE VOLTAGE 120VAC 60HZ. FOOTSWITCH CONNECTED, REVERB ON. ALL CONTROLS 50% ROT. SUPPLY VOLTAGES MAY VARY +5%, -10%. SIGNAL VOLTAGES MAY VARY ±20%. INPUT SIGNAL 1KHZ SINE.
- 5.) LAST INSTANCES: C14, CR4, CP16, J3, L1, LA1, R23, SP2, T2, V3

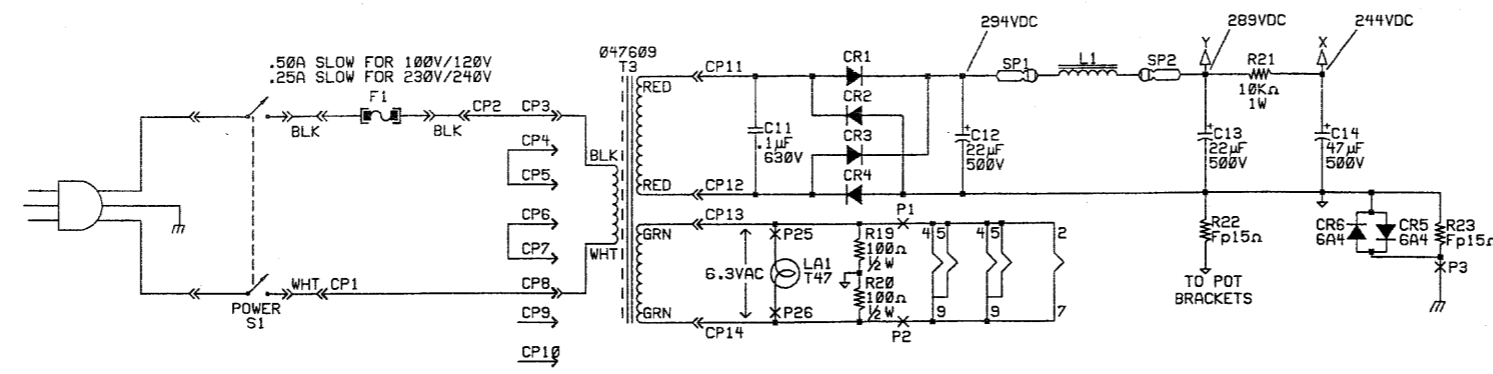

DATABASE FILE: Z263S.DBF CHECKED BY: P.WIERS DATE: 24-JUN-94 APPROVED: P.WIERS DATE: 24-JUN-94	PROPRIETARY <small>THIS DRAWING DOCUMENT CONTAINS INFORMATION WHICH IS PROPRIETARY TO AND IS THE PROPERTY OF THE FENDER MUSICAL INSTRUMENTS CO. AND MAY NOT BE USED, REPRODUCED OR DISCLOSED IN ANY MANNER WITHOUT THE EXPRESSED WRITTEN CONSENT FROM:</small> FENDER MUSICAL INSTRUMENTS CO. 1156 COLUMBIA ST. BREA, CALIFORNIA 92621 ROCK ON. NEXT HIGHER ASSEMBLY: '63 FENDER REVERB	Fender MUSICAL INSTRUMENTS 1130 Columbia Street Brea, CA 92621 TITLE: '63 FENDER REVERB SCHEMATIC DIAGRAM SIZE: D DRAWN: P.WIERS ENGR: P.WIERS DRAWING NUMBER: 047592 REV. B SCALE: NONE PLOTTED: 29-DEC-97 SHEET 1 OF 1
---	--	--

SHEET 1 of 1

REVISIONS				
ZONE	REV.	DESCRIPTION	DATE	APPROVED
	B	EC 1119	16-FEB-94	PW
	C	ECO LO 2891	25-APR-94	PW

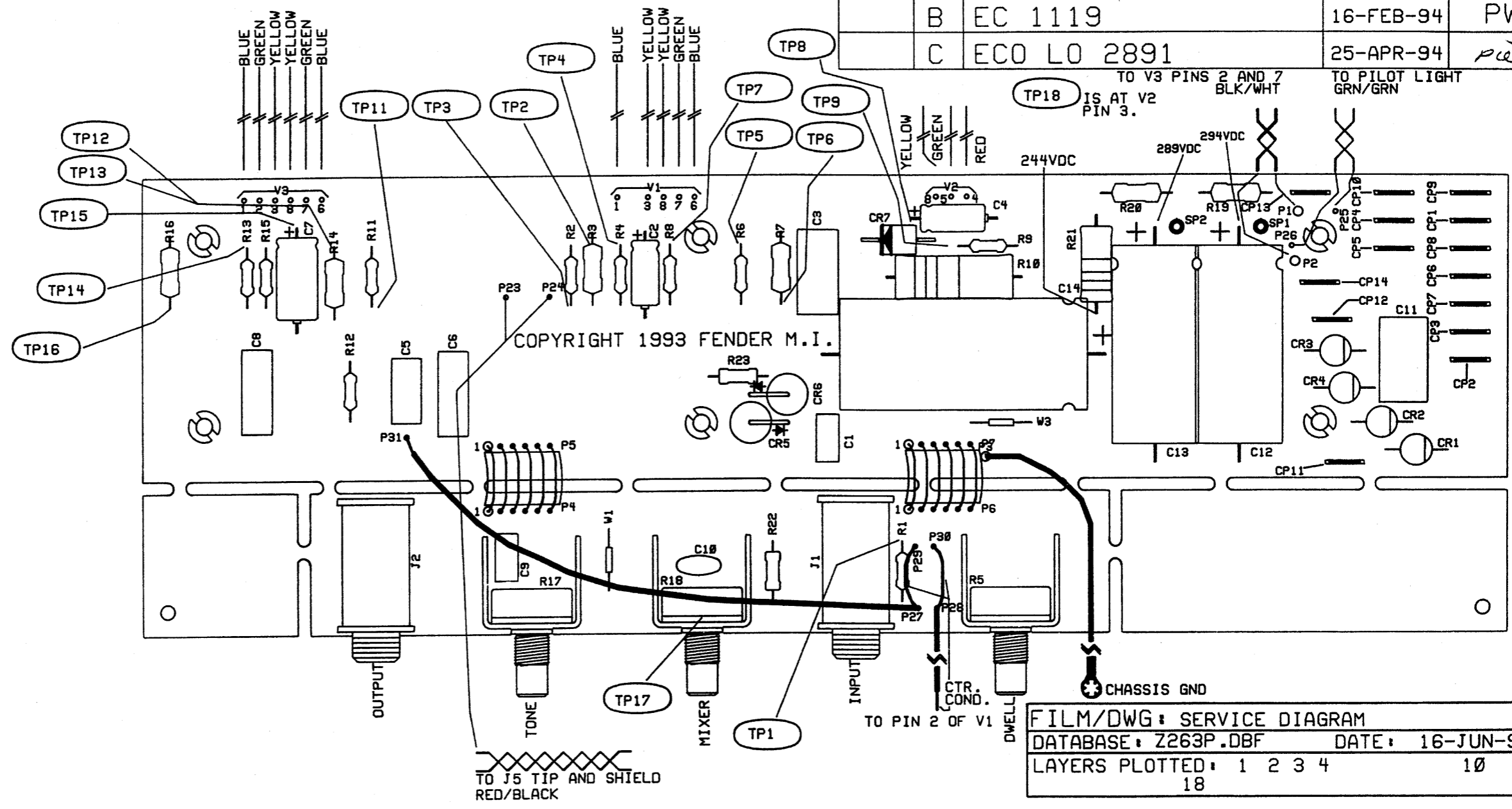

COPYRIGHT 1993 FENDER M.I.

FILM/DWG: SERVICE DIAGRAM
DATABASE: Z263P.DBF
DATE: 16-JUN-94
LAYERS PLOTTED: 1 2 3 4 10
18

DATABASE FILE: Z263P.DBF
CHECKED BY: <i>P. Wiers</i>
DATE: <i>4/22/94</i>
APPROVED: <i>P. Wiers</i>
DATE: <i>4/22/94</i>
TOLERANCES: UNLESS OTHERWISE NOTED
X.X ±0.050"
X.XX ±0.010"
X.XXX ±0.005"
ANGLES ±0.500°

PROPRIETARY

THIS DRAWING DOCUMENT CONTAINS INFORMATION WHICH IS PROPRIETARY TO AND IS THE PROPERTY OF THE FENDER MUSICAL INSTRUMENTS CO. AND MAY NOT BE USED, REPRODUCED OR DISCLOSED IN ANY MANNER WITHOUT THE EXPRESSED WRITTEN CONSENT FROM:

FENDER MUSICAL INSTRUMENTS CO.
1130 COLUMBIA ST.
BREA, CALIFORNIA 92621
ROCK ON.

NEXT HIGHER ASSEMBLY:
FINAL ASSEMBLY
'63 TUBE REVERB

Fender MUSICAL INSTRUMENTS
1130 Columbia Street
Brea, Ca. 92621

TITLE: SERVICE DIAGRAM
'63 FENDER REVERB

SIZE B	DRAWN: P. WIERS	DRAWING NUMBER	REV.
	ENGR: P. WIERS	047594	C

SCALE: CREATED: 20-DEC-93
PLOTTED: 16-JUN-94 SHEET 1 OF 1