

FERGUSON

R A D I O

MODEL

391RG

SERVICE MANUAL

ISSUED FREE TO FERGUSON ACCREDITED DEALERS

ADDITIONAL COPIES 1/3

SERVICE MANUAL

MODEL 391RG

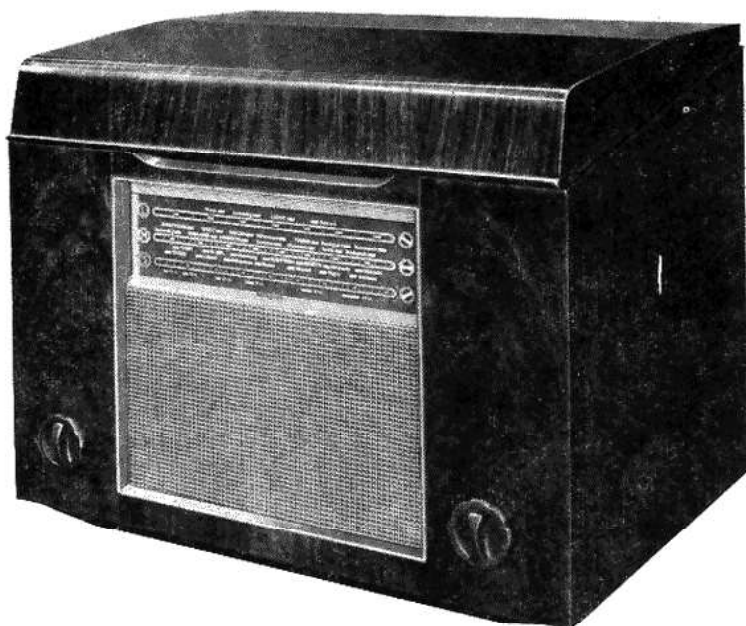

INDEX

SECTION	Page	SECTION	Page
1. General Specification	2	3. The Circuit	3
1.1 Description	2	Circuit details	4
1.2 Controls	2	4. Circuit Alignment	3
1.3 Waveband Coverage	2	4.1 General	3
1.4 Valves	2	4.2 I.F. Alignment	7
1.5 Record Changer	2	4.3 R.F. Alignment	7
1.6 Power Output	2	5. Voltage and Current Measurements	7
1.7 Loudspeaker	2	6. Mechanical Details	8
1.8 Power Supply—Mains	2	6.1 Accessibility of components	8
1.9 Cabinet	2	6.2 Removing the chassis	8
2. Installation and Operation	2	6.3 Removing the loudspeaker	8
2.1 Mains Voltage Adjustment	2	6.4 Replacing the pilot lamps	8
2.2 External Loudspeaker	3	6.5 Tuning drive	8
2.3 Gramophone Record Reproduction	3	Spare Parts List	Inside Rear Cover

ILLUSTRATIONS

Fig.		Page
1	Location of valves	2
2	Circuit diagram	4
3	Plan view of receiver chassis	6
4	Underside view of receiver chassis	6
5	Tuning drive diagram	8

TABLE RADIO - GRAMOPHONE MODEL 391RG

1. GENERAL SPECIFICATION

1.1. DESCRIPTION

Model 391 RG is a high quality table radio-gramophone incorporating a three-waveband, six valve (including rectifier) receiver with a push-pull output stage. Heavy negative feedback is applied over the audio stages and the tone control modifies the frequency characteristic of the feedback loop. External loudspeaker sockets (2-3 ohms) are provided.

1.2. CONTROLS

Four controls arranged as concentric pairs at front of cabinet.

Left-hand inner—On-Off Switch/Tone Control.

Left-hand outer—Volume

Control.

Right-hand inner—Waverange/Gram. Switch.

Right-hand outer—Tuning

Control.

1.3. WAVEBAND COVERAGE

Short Wave—15.7 to 55.4 Metres.

Medium Wave—184 to 575 Metres.

Long Wave—733 to 2050 Metres.

1.4. VALVES

(All Mullard Types)

V1. ECH 81 Frequency Changer.

V2. EBF 80 I.F. Amplifier, Detector and A.G.C.

V3. PCF 80 Audio Amplifier and Phase Invertor.

V4. EL 84 } Push-pull Audio Output

V5. EL 84 }

V6. EZ 80 H.T. Rectifier.

1.5. RECORD CHANGER

B.S.R. or Collaro RC.54, fitted with turnover crystal pick-up with sapphire styli. Record capacity—ten 12 inch, 10 inch or 7 inch records (sizes may be mixed). Speeds—78, 45 or 33½ r.p.m.

1.6. POWER OUTPUT

6 Watts for less than 1% total harmonic distortion.

1.7. LOUDSPEAKER

Elliptical, 10" x 6". Permanent magnet. Speech coil impedance—3 ohms.

1.8. POWER SUPPLY—MAINS

200 to 250 Volts A.C. 50 cycles only.

Power Consumption :

Radio — Approximately 65 Watts.

Gram — Approximately 75 Watts.

1.9. CABINET

Acoustically designed table model with top lid. Finished in walnut veneers. Dimensions : 20 ins. wide x 16½ ins. high x 14¼ ins. deep.

2. INSTALLATION AND OPERATION

2.1. MAINS VOLTAGE ADJUSTMENT

It is necessary to remove the motor board in order to gain access to the mains voltage adjustment which is mounted on the mains transformer. Remove the four motor board fixing screws. Lift the motor board at the front and draw forward before raising to the vertical position to avoid damage to the connecting leads. The motor mains leads are plugged on to the mains transformer and the pick-up leads into sockets on the chassis. These plugs may be withdrawn from their sockets so that the motor board can be removed from the cabinet if desired.

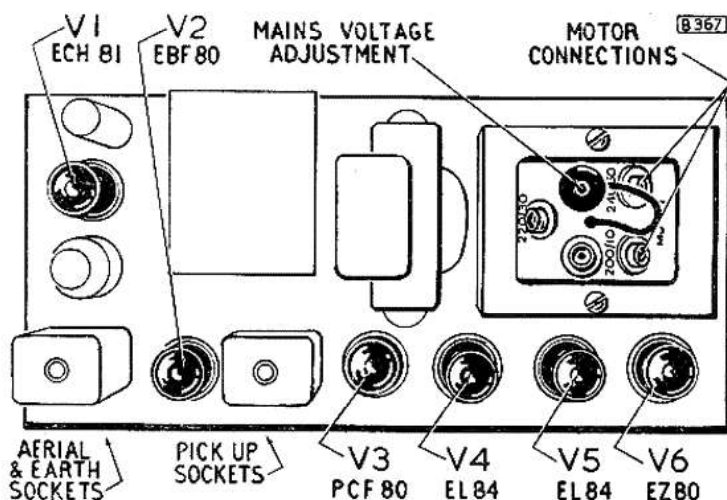

Fig. 1. Plan view of receiver chassis showing locations of valves etc.

2.2. EXTERNAL LOUDSPEAKER

Any external loudspeaker used with this instrument should have a speech coil impedance of about 3 ohms.

2.3. GRAMOPHONE RECORD REPRODUCTION

The knob on the pick-up head is marked "N" for 78 r.p.m. records and "L" for 33 $\frac{1}{3}$ and 45 r.p.m.

and should be turned so that the applicable marking is uppermost. It is essential, in order to avoid damage to records and styli, that this is correctly set.

2.3.1. Record Changer Operation

For details, reference should be made to the record changer manufacturer's instruction leaflet supplied with this model.

2.3.2. Stylus Replacement

To remove a worn stylus, lift the pick-up arm and remove the small screw which secures the metal strip to which the stylus is attached, thus releasing the strip and sapphire from the crystal cartridge. During this operation and the fitting of the replacement stylus, great care must be exercised and no undue force used.

3. THE CIRCUIT

The aerial input is via the coupling coils **L1** (S.W.) and **L2** (M. & L.W.) to the tuning coils **L3** (S.W.), **L4** (M.W.) and **L5** (L.W.) with their associated trimmers. On M.W., **R1** and **C1** are in series across **L2** and the aerial series capacitor **C2** is connected to the junction of **R1** and **L2**. On L.W., **R1** is short-circuited and **C1** then tunes **L2** to a frequency outside the waveband. The coils are selected by the switch **S1A** and tuned by **C6**. Signal voltages are applied via **C7** to the control grid of **V1** (**ECH 81**) Frequency Changer operating with a tuned grid oscillator circuit. **C12** is the oscillator tuning capacitor and the coils **L6** (S.W.), **L7** (M.W.) and **L8** (L.W.) are selected by **S2A**. **L9** is the S.W. feedback coil connected in the oscillator anode circuit. On M.W. and L.W., the "padder reactance" method of feedback is employed.

The variable-mu I.F. Amplifier **V2** (**EBF 80**) is a double-diode pentode which functions also as **Detector**. Tuned transformer couplings **C13**, **L10**, **L11**, **C14** and **C25**, **L12**, **L13**, **C26** are employed.

V2 screen grid bypass capacitor **C24** is returned to the chassis through the anode decoupling

capacitor **C29**. This method of connection applies a measure of neutralization of **V2** inter-electrode capacitance. Any substantial change in values of **R9**, **R10** and **C29** will affect the overall sensitivity of the receiver.

The detector diode load is **R13**, the volume control, and the D.C. component of the signal voltage developed across this is fed, as A.G.C. bias, to the control grid circuits of **V1** and **V2** through the decoupling circuit **R8**, **C23**. The second diode is connected to the A.G.C. line and serves to prevent the appearance of a positive potential at this point in the absence of a signal.

V3 (**PCF 80**) is a triode-pentode operating as **Audio Amplifier** and **Phase Inverter**. The audio frequency component of the rectified signal appearing across **R13** is applied via **C31** to the pentode control grid. Anode and cathode loads in the triode section of **V3** produce a push-pull output and as the triode cathode is at a higher potential with respect to chassis than the pentode anode, the latter is directly coupled to the triode grid. The pentode screen grid potential is derived from the triode cathode circuit through the decoupling resistor **R17** by-

passed by **C32**.

Anti-phase signal voltages developed across **V3** triode anode and cathode loads, **R19** and **R18** are applied through **C33** and **C34** to the control grids of **V5** and **V4** (**EL 84's**) which comprise the push-pull pentode output stage. The grid stoppers, **R29** and **R30**, were not included in earlier production. Negative feedback voltage is taken from the secondary of the output transformer **T1** and is injected, through the network **R26**, **R21**, **C35** and **C37** across **V3** pentode cathode resistor **R15**. **R21** is the tone control and the setting of its slider (because of the connection of **C35**) determines the frequency characteristic of the feedback loop. When **R19** slider is at the end nearer to **R15**, negative feedback at high audio frequencies is increased and the amplifier response at these frequencies will therefore fall.

H.T. current is supplied by the full-wave rectifier **V6** (**EZ 80**), fed from the mains transformer **T2**, and smoothed by the reservoir capacitor **C40** and the two-section filter **R28**, **C39**, **R27** and **C38**. The heaters of **V1**, **V2**, **V4**, **V5**, **V6** (**6.3 Volts**) and of **V3** (**9 Volts**) are fed by the tapped L.T. winding on **T2**.

4. CIRCUIT ALIGNMENT

4.1. GENERAL

Access to the majority of the trimmers may be obtained by removing the inspection plate beneath the cabinet. For R.F.

alignment, no further dismantling is necessary, but in order to reach the top I.F. adjustments the motor board must also be removed. Calibration markers are

provided on the tuning scales. These markers take the form of small dots beneath the wavelength scale for each waveband.

Continued on Page 7

CIRCUIT DETAILS

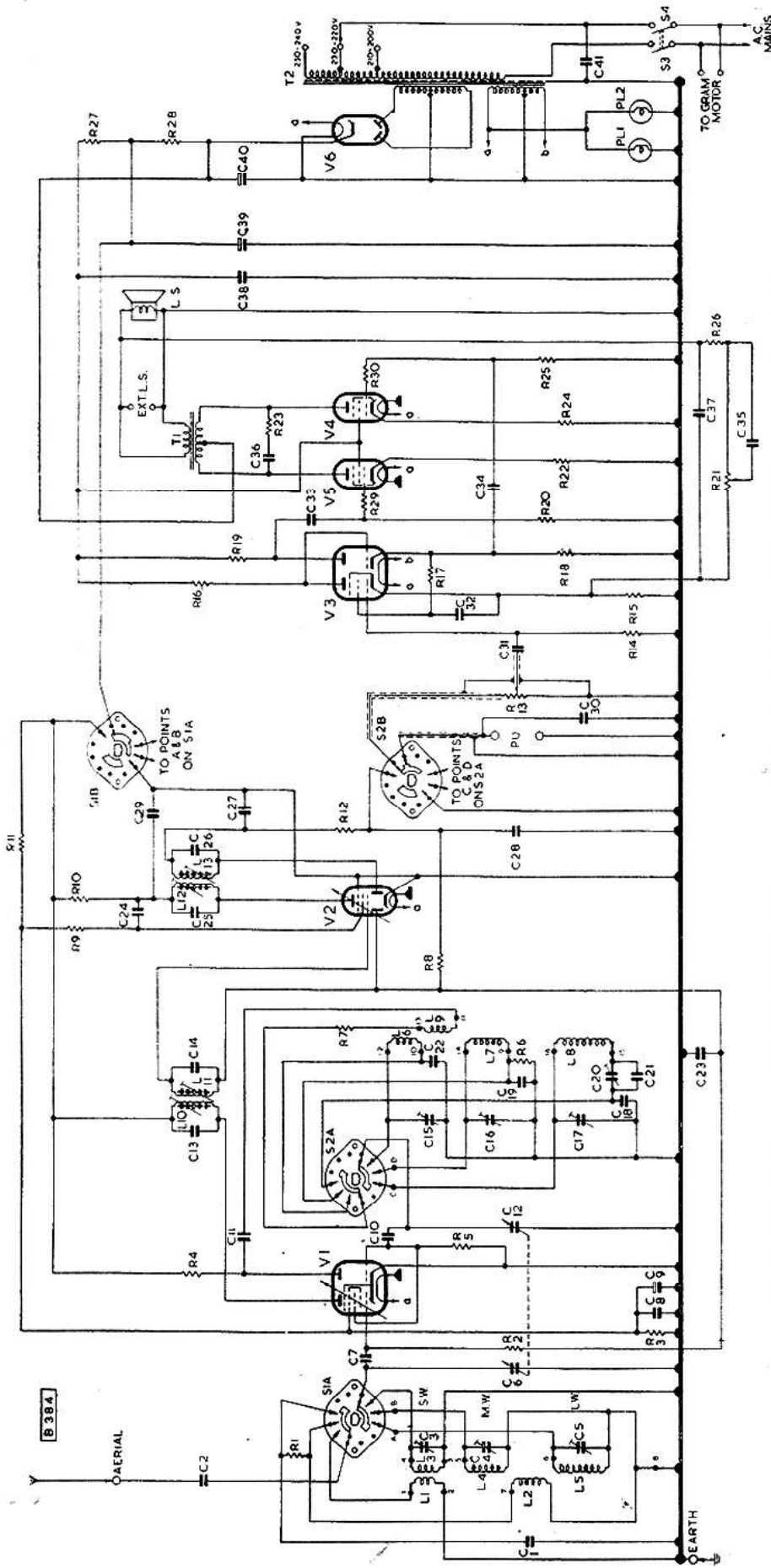

Fig. 2. Circuit diagram of Model 391RG with component values listed below. R29 and R30 were not included in early production.

CAPACITORS

(All 20% tolerance 350V. working unless otherwise stated.)

Ref.	Value	Rating	Function	Location
C 1	500 pF		L.W. ae. coupling tuning	G1
C 2	0.001 uF	1000 V.	Aerial isolating	H2
C 3	15 pF	Pre-set	S.W. ae. trimmer	G1
C 4	40 pF	Pre-set	M.W. ae. trimmer	G1
C 5	65 pF	Pre-set	L.W. ae. trimmer	G1
C 6	528 pF	Variable	Aerial tuning	B1
C 7	200 pF		V1 heptode C.G. coupling	H1
C 8	0.1 uF*	200 V.	V1 S.G. bypass	H2
C 9	16 uF*		Oscillator C.G. coupling	H1
C10	50 pF			

RESISTORS

(All 20% tolerance 1/4 Watt carbon unless otherwise stated.)

Ref.	Value ohms.	Rating	Function	Location
R 1	3.3 K		M.W. Aerial coupling	G1
R 2	1 M		V1 heptode grid leak	H2
R 3	56 K		Part V1 V2 S.G. Pot. Div.	H1
R 4	47 K		Oscillator H.T. feed	H1
R 5	47 K		Oscillator grid leak	H1
R 6	3.3 K		M.W. Oscillator limiter	H1
R 7	220		S.W. Oscillator limiter	H2
R 8	1 M		A.G.C. decoupling	G2
R 9	1 K		V2 S.G. H.T. feed	H2
R 10	1 K		V2 anode H.T. feed	H2
R 11	27 K	10%	Part V1, V2, S.G. Pot. Div.	H2

INDUCTORS AND TRANSFORMERS

(D.C. Resistance not given if less than 1 ohm.)

Ref.	Function	Approx. Resist. ohms.	Location
L 1	S.W. Aerial Coupling	2.3	A1
L 2	M. & L.W. Aerial Coupling	28.0	A2
L 3	S.W. Aerial Tuning	—	A1
L 4	M.W. Aerial Tuning	2.6	A2
L 5	L.W. Aerial Tuning	30.0	A2
L 6	S.W. Oscillator Tuning	—	H2
L 7	M.W. Oscillator Tuning	2.5	H2
L 8	L.W. Oscillator Tuning	15.0	H2
L 9	S. & M.W. Oscillator Feedback	1.0	H2
L10	{ 1st I.F. Transformer	8.0	{ Pri.
L11	{	8.0	{ Sec.

L12	2nd I.F. Transformer	Pri.	8.0	B2
L13	Audio Output Transformer	Sec.	6.0*	B1
T 1	Mains Transformer	Pri. (total)	325	
		Sec.	28	
T 2	Mains Transformer	H.T. Sec. (total)	340	C1
		L.T. Sec.		

* Not measurable externally. R12 is included in I.F. can.

MISCELLANEOUS

Ref.	Description	Location
S1A	Aerial Coils Switch	G1
S1B	Radio/Gram H.T. Switch	G1
S2A	Oscillator Coils Switch	G1
S2B	Radio/Pick-up Switch	G1
S3	Mains On/Off Switches (ganged with R21)	E1
S4	Pilot lamps 6.5V, 0.3A, 12 mm. clear	A1
PL1	spherical bulb, M.E.S. base	D1
PL2	10" x 6" elliptical type P.M., 3 ohms	Cab.
L.S.	speech coil	

B2	I.F. filter			
E1	Volume control			
G2	V3 pentode grid leak			
G2	V3 pentode grid bias			
G2	V3 pentode anode load			
G2	V3 S.G. H.T. feed			
G2	V3 triode cathode load			
G2	V3 triode anode load			
F2	V5 grid leak			
E1	Carbon Pr. Lin. Tone control			
F2	W. V5 grid bias			
F2	W. Tone compensation			
F2	W. V4 grid bias			
F2	V4 grid leak			
B1	Neg. feedback limiter			
E2	W. H.T. smoothing			
F2	V5 grid stopper			
F2	V4 grid stopper			

VALVES (All Mullard Types)

Ref.	Type No.	Function	Location
V1	ECH 81	Frequency Changer	A1
V2	EBF 80	I.F. Amp., Det. and A.G.C.	A2
V3	PCF 80	A.F. Amp. and Phase Inverter	B2
V4	EL 84	Push-pull A.F. output	C2
V5	EL 84	H.T. rectifier	D2
V6	EZ 80	H.T. rectifier	D2

C11	200 pF	Oscillator anode coupling	H1
C12	528 pF	Oscillator tuning	B1
C13	100 pF	1st I.F.T. tuning	A2
C14	15 pF	S.W. oscillator trimmer	H2
C15	40 pF	M.W. oscillator trimmer	G2
C16	65 pF	L.W. oscillator trimmer	G2
C17	500 pF	Part L.W. padder	H1
C18	560 pF	M.W. padder	H2
C19	80 pF	Part L.W. padder	H2
C20	200 pF	S.W. padder	H1
C21	3550 pF	A.G.C. decoupling	H2
C22	0.1 uF	V2 S.G. bypass	H2
C23	0.1 uF	2nd I.F.T. tuning	B2
C24	100 pF	I.F. filter	B2
C25	180 pF	V2 anode decoupling	G2
C26	100 pF	P.U. shunt	G2
C27	100 pF	V3 pentode C.G. coupling	G2
C28	0.005 uF	V3 pentode S.G. decoupling	G2
C29	0.001 uF	V5 C.G. coupling	F2
C30	0.002 uF	V4 C.G. coupling	F2
C31	0.25 uF	Part tone control circuit	D1
C32	0.05 uF	Tone compensation	B1
C33	0.05 uF	Negative feedback	B1
C34	0.05 uF	H.T. smoothing	E2
C35	0.04 uF	H.T. reservoir	E2
C36	0.001 uF	Mains R.F. bypass	D1
C37	300 pF		
C38	24 uF*		
C39	24 uF*		
C40	32 uF*		
C41	0.01 uF		

* Electrolytic.
† Swing value.
‡ Maximum value.

VALVE BASE CONNECTIONS

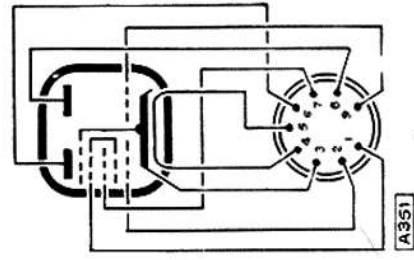

ECH 81

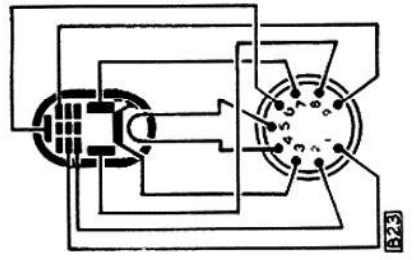

EBF 80

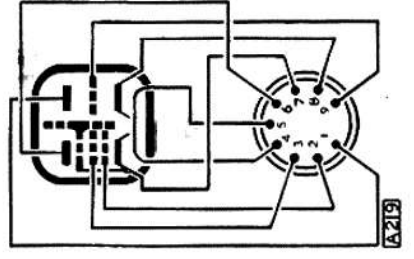

PCF 80

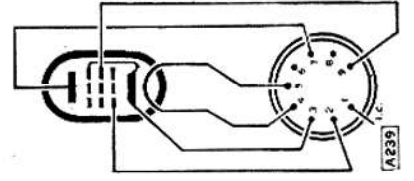

EL 84

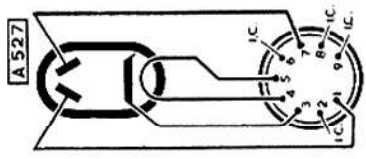

EZ 80

391RG SERVICE MANUAL

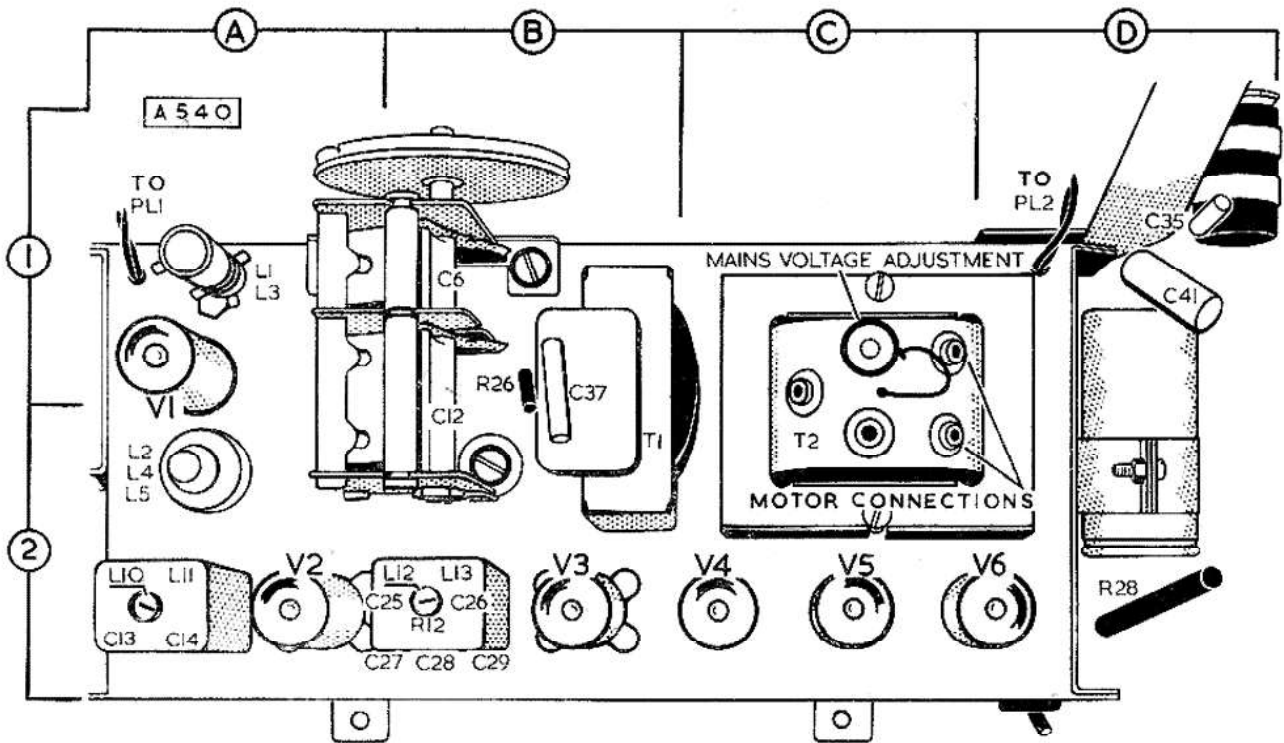

Fig. 3. Plan view of receiver chassis, showing locations of valves and components.

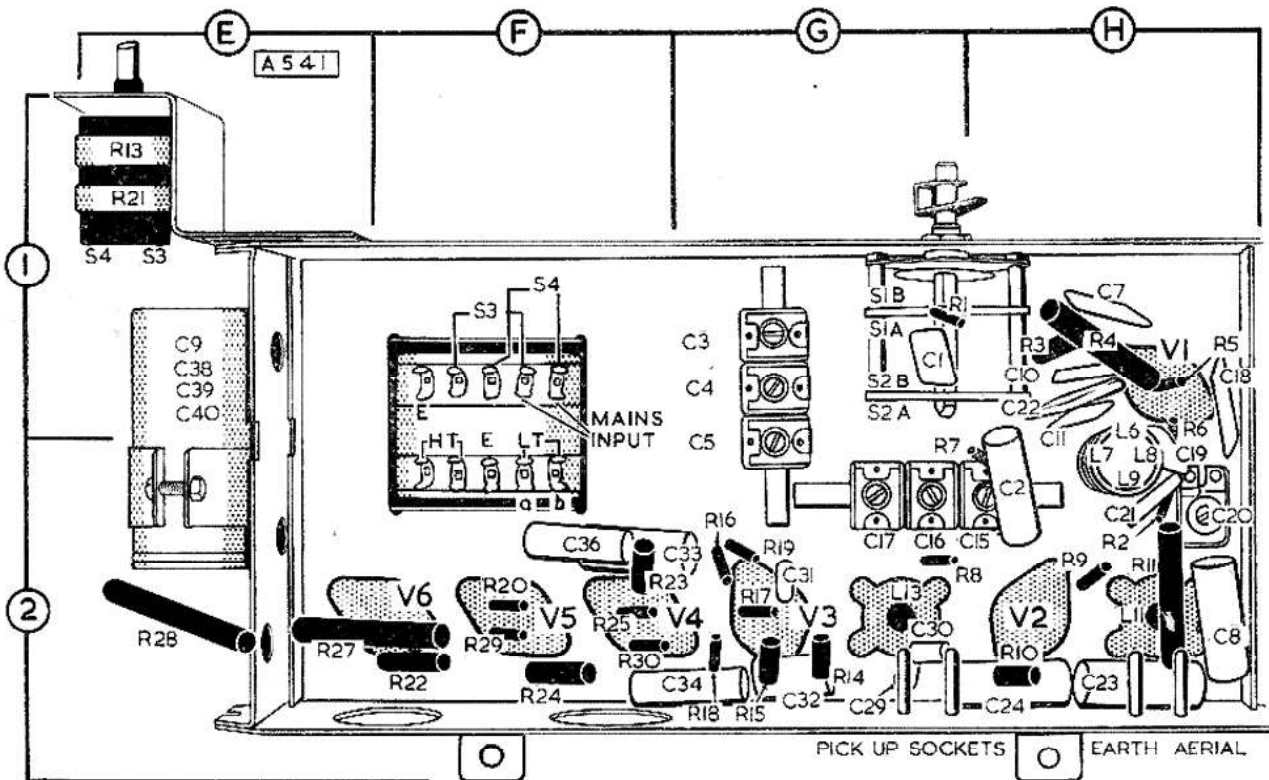

Fig. 4. Underside view of receiver chassis, showing locations of components.

Circuit Alignment cont.

The cursor setting with the gang at maximum capacitance is indicated by the extreme right-hand dots inside each wavelength scale.

The scale remains in the cabinet when the chassis is removed. To facilitate alignment under these conditions, five small holes are provided in the cursor guide bar to serve as markers. From left to right, they indicate the following:—

1. **M.W.** and **S.W.** trim point.
2. **L.W.** trim point.
3. **M.W.** check point.
4. **S.W.** check point and **L.W.** pad point.
5. Cursor setting for gang max.

When using these points for alignment, the left-hand edge of the cursor carriage should be made to register with the centre of each hole.

Throughout alignment the input signal should be kept at the lowest level that will give a readable deflection on an output meter or other suitable indicating device connected across the external loudspeaker sockets. The volume control should be turned to maximum and the tone control to the "maximum top" position.

4.2. I.F. ALIGNMENT

Turn the gang to maximum capacitance and set the wave-range to switch to M.W. Connect the signal generator output across **C6** (front section of gang) and inject a signal of 470 Kc/s.

Adjust **L13**, **L12**, **L11** and **L10**, in that order, for maximum output, progressively reducing the input as each circuit is brought to resonance.

4.3. R.F. ALIGNMENT

Transfer the signal generator output to the aerial and earth sockets. Check that the cursor is correctly set when the gang is at maximum. Align at the following frequencies in the order given:—

L.W. 350 Kc/s. Trim. Adjust **C17** and **C5** for maximum output.

160 Kc/s. Pad. Adjust **C20** for maximum output.

Repeat these adjustments until no further improvement results.

M.W. 1500 Kc/s. Trim. Adjust **C16** and **C4** for maximum output.

580 Kc/s. Check. Check calibration.

S.W. 17 Mc/s. Trim. Adjust **C15** for maximum output and slightly rock gang whilst adjusting **C3** for maximum.

6 Mc/s. Check. Check calibration.

Fixed tracking is employed on M.W. and S.W.

5. VOLTAGE AND CURRENT MEASUREMENTS

The following figures are averages of measurements made on a number of receivers and are provided only as a guide since individual receivers may differ to some extent. All the readings were taken on a Model 7 Avometer, voltages being measured on the 400 V. range except in the case of **V4** and **V5** cathode potential for which the 10 V. range was used.

The receivers were switched to M.W. with the gang closed. The mains input was 240 V. A.C., 50 c.p.s., to the 240-250 V. tapping on the mains transformer.

General Measurements

Total H.T. current	78 mA
H.T. Voltage (reservoir)	300 V
H.T. Voltage (1st section smoothing)	265 V
H.T. Voltage (2nd section smoothing)	200 V

Valve Measurements

Ref.	Valve Type	Anode		Screen		Cathode	
		Volts	mA	Volts	mA	Volts	
V1	ECH 81 Hept. Tri.	...	265	2.2	62	4.8	—
		...	75	3.8	—	—	—
V2	EBF 80	...	260	4.2	59	1.4	—
V3	PCF 80 Pent. Tri.	...	*	*	*	*	*
		...	97	0.7	—	—	60
V4	EL 84	...	290	27	200	3	6.7
V5	EL 84	...	290	27	200	3	6.7
V6	EZ 80	...	275†	—	—	—	300

* These measurements are impracticable because of very high resistances in V3 anode and screen circuits.

† A.C. (r.m.s.).

6. MECHANICAL DETAILS

6.1. ACCESSIBILITY OF COMPONENTS

Access to the majority of the under chassis components may be gained by removing the inspection plate beneath the cabinet. Those on the top side of the chassis can be reached by removing the motor board which is secured by four screws. To prevent damage to the motor and pick-up leads, the motor board should be lifted at front, drawn forward and then raised to the vertical position. The motor leads plug on to the mains transformer and the pick-up leads plug into sockets at the rear of the chassis. The motor leads are cleated to the side of the cabinet. When the leads are un-plugged, the motor board may be completely withdrawn.

6.2. REMOVING THE CHASSIS

Remove motor board and inspection plate. Draw the control knobs forward to disengage them from the spindles. In later production, both small and large knobs may be completely withdrawn but in earlier receivers, the large knobs are fitted with retaining rings and will remain in the cabinet.

Unsolder the internal and external loudspeaker leads from the output transformer and release the cleat securing the mains lead to the cabinet bottom. Remove the wood backing plate behind the scale, also the two 2BA bolts which secure the cursor guide bar to the front of the cabinet. It should be noted that the scale may become dislodged from its recess when the backing plate is

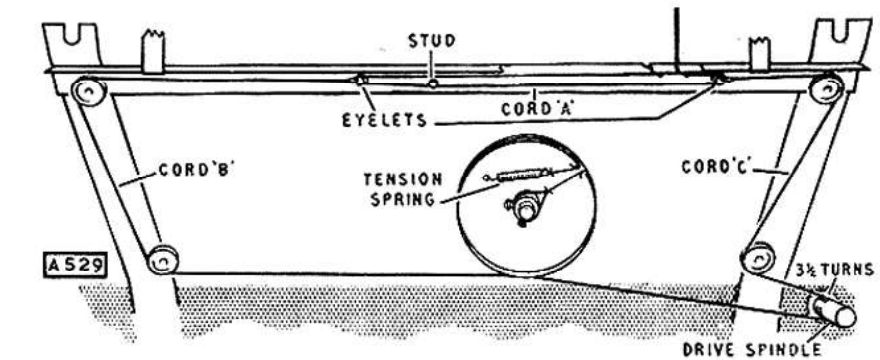

Fig. 5. The tuning drive.

removed and it should not be left in a cabinet from which the chassis has been removed unless the plate is in position. Remove the four 2BA bolts which secure the chassis to the cabinet bottom. The chassis may then be lifted out.

When replacing the chassis, the mains lead should be taken out through the inspection trap and the external loudspeaker leads should be arranged to lie between the EBF 80 and the second I.F.T. It is important to keep these leads away from the audio valves.

6.3 REMOVING THE LOUDSPEAKER

First remove the chassis as described above, then release the four nuts which secure the loudspeaker clamps.

6.4. REPLACING THE PILOT LAMPS

These become accessible on removal of the scale backing plate

which can be accomplished from inside the record changer well.

6.5. TUNING DRIVE

Three separate cords are arranged as shown in Fig. 5 and a total length of about 6 feet should be allowed. The drive drum is shown in the position it should occupy when the gang is closed. First tie cord A to the stud, forming a loop which should measure $6\frac{3}{4}$ inches from centre to centre of the eyelets. Attach cord B to drive drum bush and at a distance of 22 inches, tie to left-hand eyelet within loop (cord A). Pass cord B round drum and pulleys as shown. Tie a further cord (C) to right-hand eyelet in loop, pass it over the pulleys, make $3\frac{1}{2}$ turns clockwise round drive spindle and return it to the drum, attaching the end of the cord to the tension spring as shown. Attach the cursor, adjusting its position so that the left-hand edge of the cursor carriage coincides with the centre of the extreme right-hand hole in the guide bar when the gang is at maximum.

391RG SERVICE MANUAL

SPARE PARTS LIST

Part Description	Part No.
Cabinet	V12769
Coil, S.W. Aerial	Y6889
Coil, M. and L.W. Aerial	Y6890
Coil, S., M and L.W. Aerial	Y6891
Control Knob (Tone/On-Off)	Y11074
Control Knob (Tuning)	Y11077
Control Knob (Volume)	Y11075
Control Knob (W/C Switch)	Y11076
Cursor Assembly	Z12044
Drive Drum	Z11711
Electrolytic Capacitors :—	
32—24—24 uF, 350 V.W., 425 V. Surge,	
—16 uF, 200 V.W.	Y13200/3
I.F. Transformer (1st)	Y5436
I.F. Transformer (2nd)	Y7170
Loudspeaker (10in. x 6in. Elliptical)	Z11713
Mains Transformer	X11706
Output Transformer	Y12054
Scale	Y11395
Tuning Capacitor	X9124
Volume/Tone Control and On-Off Switch	Y11704
W/C Switch	X11073

Manufacturers . . .

FERGUSON RADIO CORPORATION LTD.

GREAT CAMBRIDGE ROAD, ENFIELD, MIDDLESEX

A Subsidiary of . . .

THORN ELECTRICAL INDUSTRIES LTD.

HEAD OFFICE :

105 - 109, JUDD STREET, LONDON, W.C.1

SALES DEPT. AND SHOWROOMS :

233 SHAFTESBURY AVENUE, W.C.2.

**All Service enquiries should be addressed to
the Local TEI Service Depot**

SERVICE DEPOTS

LONDON : 145 KENTISH TOWN ROAD, N.W.1.

Telephone : GULLiver 6633.

BIRMINGHAM : 24 SHEEPCOTE STREET, 15

Telephone : Midland 5291.

Telegrams : Eleclampo, Birmingham.

MANCHESTER : 9 STEVENSON SQUARE

Telephone : Central 3185.

Telegrams : Eleclampo, Manchester.

GLASGOW : 9/15 WAVERLEY STREET,

SHAWLANDS, S.1.

Telephone : Langside 1242