

FERGUSON

TAPE RECORDER MODEL 442TR

'FERGUSON' is the registered trade mark of THORN ELECTRICAL INDUSTRIES LTD.

SERVICE MANUAL

SPECIFICATION

Mains Supply

50 cps alternating current 200-225 and 225-250 volts

Power Consumption

60 watts on both record and replay

Magnetic Heads

Standard quarter track
Two record/play stacked
Two erase (double gap) stacked

Frequency Range

50-10,000 cps

Controls

Combined volume control and recording level control
Mains On/Off switch combined with a continuously variable tone control

Switching Facilities

A record switch interlocking with the Record/Replay control to prevent accidental erasure
Track selector switch
Straight through amplifier switch

Tape Speed

3½ inches per second

Record Level Indicator

Cathode-ray type (EM84) peak indicator

Tape

The Tape Recorder is supplied with a 5½ inch spool of LP tape

Playing Time

The following list gives the playing times for various spool sizes of LP tape, the grade of tape recommended for general use

Size	Feet (per track)	Playing Time (minutes per track)
3 inch	300	16
5 inch	900	48
5½ inch	1255	66

Rewind Time

Fast forward and fast rewind. 3 minutes for 5½ inch reel of standard tape (4½ ft/sec)



Sockets

Microphone input : 2mV into 10MΩ
Radio input : 2mV into 22KΩ
Pick-up input : 100mV into 1MΩ
Radio output : 500mV at 22KΩ
External loudspeaker : 2.5W at 35Ω
Automatic muting of internal loudspeaker with external loudspeaker plug inserted

Loudspeaker

7 inches x 3½ inches elliptical loudspeaker

Cabinet Dimensions

14¾ inches wide x 12¼ inches deep x 7 inches high

Weight

(Including microphone, two tape spools, etc.) 17 lbs

The manufacturers reserve the right to vary specifications or use alternative materials as may be deemed necessary or desirable at any time.

SERVICE NOTES AND ADJUSTMENTS

Chassis Removal

1. Remove tape spools and any plug connections.
2. Lift off head cover.
3. Pull off four control knobs (Volume, tone, Record/Play and Mechanism control).
4. Unscrew six top cover fixing screws (replace serial No. label when re-assembling).
5. Lift off top cover.
6. Unscrew four chassis fixing screws and washers.
7. The chassis is now free to be removed from the case. The loudspeaker leads are of sufficient length for most servicing requirements.

Cleaning

Before attempting any cleaning maintenance the recorder must be disconnected from the mains supply.

Do not allow a screwdriver or anything made of iron or steel to come in contact with the recording heads. The working face of the magnetic heads, capstan and pinch wheel need occasional cleaning. Use a soft cloth, dampened with methylated spirit and place over a matchstick or wooden spill to clean tape guides as well as the record and erase heads. **DO NOT USE PETROL OR CARBONTETRACHLORIDE.**

Heater Balance

A humdinger R26 is provided across

the mains transformer heater winding. This has been set during manufacture and should not need altering. If adjustment does become necessary, the procedure given below must be carefully followed.

Whilst setting the adjustment the chassis must be electrostatically screened, particularly around V1 and the input sockets. A shallow metal box, of suitable size and connected to the chassis metalwork, may be used.

Take off the tape spools and set the instrument to "record". Connect a sensitive valve voltmeter, between the junction of C8/R16 and chassis.

Short circuit R18 to prevent the oscillator from functioning and plug in a dummy microphone connector consisting of a 1000pF capacitor strapped across the plug.

Switch on and allow to warm up for 10 minutes.

Adjust R26 for minimum reading on the valve voltmeter (approximately 80mV).

Oscillator Level

Set instrument to "Record" and connect valve voltmeter across the top winding of erase head. Switch on and allow to warm up for 10 minutes. Select track "1-4" and adjust R18 for a reading of 14 volts. Connect valve voltmeter to the lower winding of erase head and select track "2-3". If reading is less than 14 volts readjust R18 for this figure.

Head Adjustment

Two adjusting screws are provided on each head mounting to enable the heads to be accurately aligned. Do not overtighten otherwise the head mounting might become distorted.

One of the screws on the record/replay head is fitted with a spring washer, adjust this screw so that the spring is lightly compressed, then align the head gap so that it is visually at right angles to the tape motion. Select tracks "1-4" and replay a standard alignment tape. Adjust screw without spring washer for maximum output meter reading. Note setting of this screw (pencil mark on chassis). Select tracks "2-3" and adjust the screw for maximum output meter reading on alignment signal. Mark this setting and adjust screw to midway between the two marks, to obtain a compromise alignment for both tracks. To realign the erase head, ensure that the gaps are visually at right angles to the tape motion, and make final adjustments to obtain complete erasure on a previously recorded tape.

Head Demagnetisation

It is important that there is no residual magnetism in the magnetic heads or any other part in close proximity to the recording tape such as the capstan and tape guides.

If these become slightly magnetised in use, the background noise on the recordings will increase. Suitable instruments for providing a demagnetising field are available from a number of manufacturers.

Microphone

Due to difficulty in re-assembling and danger of damage to the crystal element, it is suggested that no servicing is carried out on the microphone. In the case of any fault developing in the component it should be returned to the nearest service depot.

Tape Deck

A chart of the more common faults and their remedies is given on page 4. Should any component be found faulty and worn, replacement parts can be obtained direct from Birmingham Sound Reproducers Ltd., by quoting part number (see exploded view on page 5).

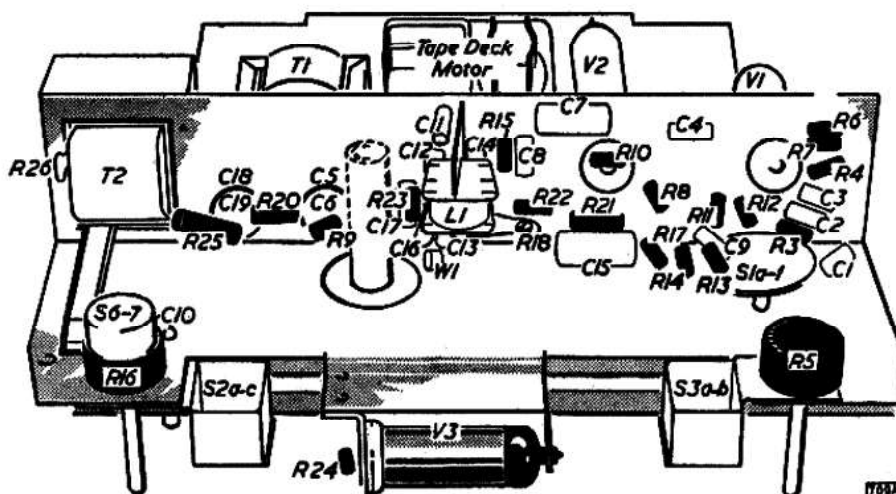

Chassis component layout.

CIRCUIT DESCRIPTION

The AC mains supply is switched to the primary of T2 and tape deck motor by a double pole switch S6-7. T2 primary is tapped to provide two alternative ranges of mains input voltages. HT supply is provided by a full wave selenium metal rectifier W2 type EC1. The parallel heater chain is balanced to chassis by means of a preset potentiometer R26 across the heater winding of T2.

Replay

The head winding for the appropriate track is selected by the track selector switch S2a/S2b. The head output voltage is switched by S1a to the grid of V1A (ECC83), the other side of the head winding being returned to chassis via S1b. The amplified signal at V1A anode is then fed via the volume control R5 to the grid of V1B, which, with V2A (ECL82) provides two further stages of amplification. A frequency selective feedback loop, switched by S1c from V2A anode to V1B cathode, gives bass boost playback equalisation. A measure of correction for HF head losses is applied by resonating the head with C1.

V2A output is fed direct to the "radio" output socket via potential divider R13/R14 and S1d and via C8 to tone control R16. From the tone control the signal is switched by S1f to the grid of V2B via a grid stopper R17. V2B operates as the audio output stage, with the erase head short circuited by S1e. The secondary of T1 is connected in the return circuit of the cathode of V2B to provide negative feedback. The internal loudspeaker is automatically muted when the external loudspeaker connection is made at the jack socket.

Record

The input sockets are switched to V1A grid by S1A or S3 (Note: The position of S3 is immaterial during recording). Switch contacts are incorporated in the microphone jack to break the radio and pick up input circuit when the microphone is in use. V1A output is fed via the record level control R5 to V1B grid. Negative feedback is applied via S1c and R11. Treble boost is applied by resonating the head with C11.

V2A output is fed to the record/playback head via C8 and a series resistor R15, to provide constant current drive. The record/replay head winding is returned to chassis through S1b. Part of the signal developed at V2A anode is rectified by W1, and fed to the grid of V3 the record level indicator. The values of C17 and R23 in V3 grid circuit have been chosen to allow peak programme levels to be indicated whilst retarding the return to lower volume levels. Power for erasing and recording bias is supplied by V2B which is connected as a modified Hartley oscillator when the instrument is switched to "Record." The oscillator is tuned to approximately 54Kc/s by L1/C12 and the output is fed from the secondary winding of L1 to the erase head via S5a/S2c and to the recording head through C11 and S2b.

Superimpose

S5a switches out the erase head and connects a resistive load into circuit to maintain correct oscillator operating level.

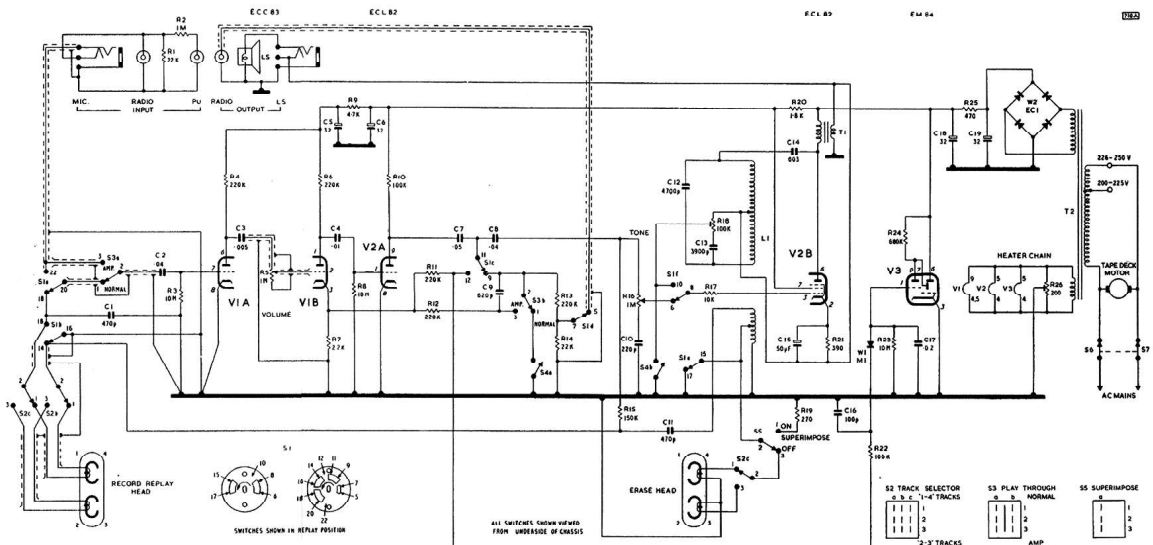

Model 442TR Circuit Diagram. Figures in rectangles are voltage readings taken with a 20,000 ohm/volt meter. Figures adjacent to the valve electrodes denote pin connections.

Playthrough

When used as a "playthrough" amplifier, the record/play switch must be left in the play position. The playthrough switch S3A disconnects the record/play head from V1A grid and brings the input sockets into circuit. The other section of the playthrough switch (S3b) shortcircuits C9 in the negative feedback loop, removing bass boost.

Muting Switch

S4a shorts the signal at V2A anode to chassis thus muting the signal during fast rewind and, hum and noise when the mechanism control is in the off position.

S4b produces decaying oscillations so ensuring that the erase head is not left partially magnetized.

SERVICE CHART

SYMPTOMS

- (1) Tape does not move when unit is switched on and control knob is in operating position
- (2) Take-up spool does not rotate
- (3) No movement or slow movement of tape on fast forward or rewind position
- (4) Tape spills when applying brakes, during normal playing or on fast forward or rewind
- (5) Variation of tape speed
- (6) Variation of sound volume

CAUSE

- (1) No current to motor
 - (2) Defective motor
 - (3) Intermediate wheel slipping
 - (4) Pressure roller not pressing tape firmly against capstan
 - (5) Tape jamming in guide due to faulty splicing or accumulation of dust
 - (6) Tape slip at capstan
- Driving belt from capstan to friction pulley assembly detached or detached
- (1) Support arm spring strained or detached
 - (2) Spool support casting tight on spindle
 - (3) Slip between motor pulley and spool carrier
- (1) Brake arms not operating due to detached or strained brake arm spring
 - (2) Brake arms sticking
 - (3) Brake slipping
- See levers 3, 4, 5 and 6 of Symptom (1)
- (1) Accumulation of dust on face of playback head
 - (2) Damaged or distorted pressure and spring
 - (3) Defective amplifier

REMEDY

- Check mains supply to motor
Repair or replace
- Wipe clean of grease or oil; replace wheel if distorted
- (a) Check that pressure roller spindle is free to move in slot and that the springs push the spindle towards the front of the slot
 - (b) Check that the pressure lever assembly moves with a positive action
- Free tape and clean tape guides
- Clean capstan and pressure roller and ensure that they are free from oil and grease
- Replace belt in driving groove of capstan and friction pulley
- Replace spring
- Remove and clean. Assemble with light grease
- Clean motor pulley, jockey pulley and rim of spool carrier
- Replace spring
- Check that brake arms move freely under the action of spring. Examine arms for distortion etc.
- Clean brake pad and rim of spool carrier and ensure that they are free from oil and grease
- Clean head face
- Adjust pad and spring, pressure should be 15-20 grms
- Check amplifier and speaker

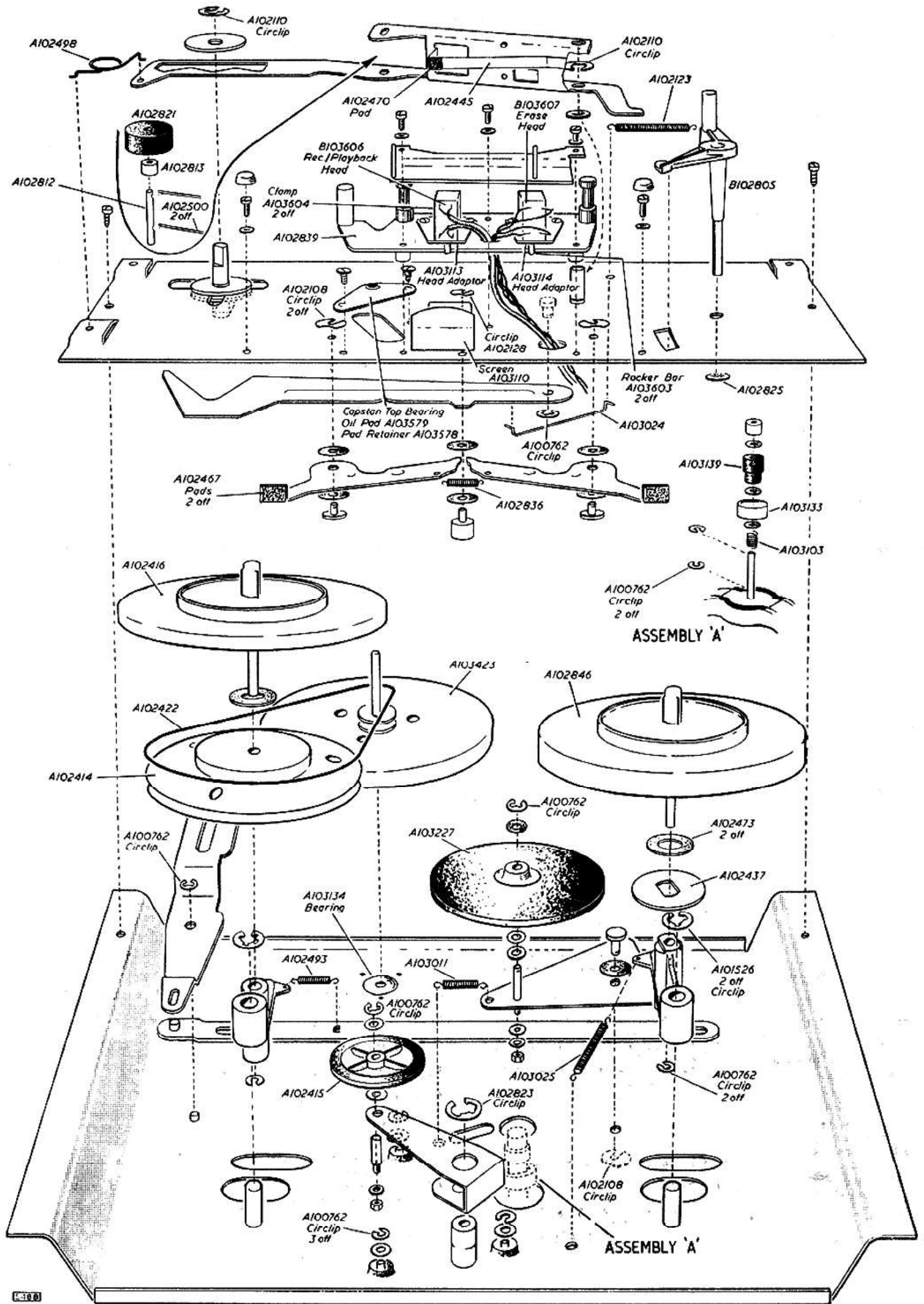

RESISTORS

All $\frac{1}{2}$ Watt carbon 20% tolerance unless otherwise stated

Ref	Value	Rating	Function and Part No.
R 1	22K Ω	10%	Radio input and part pick-up attenuator
R 2	1M Ω		Part pick-up input attenuator
R 3	10M Ω		V1A grid leak
R 4	220K Ω	5% Low Noise	V1A anode load
R 5	1M Ω	Log Pot	Volume/Record level control 13144
R 6	220K Ω		V1B anode load
R 7	2.2K Ω	10%	V1B cathode bias and NFB injection
R 8	10M Ω		V2A grid leak
R 9	4.7K Ω		Part HT smoothing
R10	100K Ω		V2A anode load
R11	220K Ω	10%	Part record NFB (treble boost)
R12	220K Ω	10%	Replay NFB (bass boost)
R13	220K Ω		Radio output attenuator
R14	22K Ω		
R15	150K Ω	10%	Record head signal feed
R16	1M Ω	Lin Pot	Tone control 13145
R17	10K Ω		V2B grid stopper
R18	100K Ω	Pre-set	Oscillator amplitude control
R19	270 Ω	5% $\frac{1}{2}$ W	Oscillator load (superimpose)
R20	1.8K Ω	10% $\frac{1}{2}$ W	Part HT smoothing
R21	390 Ω	10% $\frac{1}{2}$ W	V2B cathode bias
R22	100K Ω		W1 stand off
R23	10M Ω		V3 grid leak and W1 load
R24	680K Ω		V3 anode load
R25	470 Ω	10% 1W	Part HT smoothing
R26	200 Ω	Pre-set	Heater balance (humdinger)

MISCELLANEOUS

Ref	Description	Part No.
LS	7 inches x 3 $\frac{1}{2}$ inches elliptical 3 Ω speech coil	16009/1
S1a-f	Record/Play switch	30366
S2a-c	Track selector switch	30435
S3a-b	Playthrough switch	30435
S4a-b	Muting switch	30358
S5	Superimpose switch	18399
S6-7	Mains On/Off switch	13145
W1	Record level rectifier	18296
W2	HT rectifier	17599

CAPACITORS

All 350 Volts 20% tolerance unless otherwise stated

Ref	Value	Rating	Function and Part No.
C 1	470pF	2 $\frac{1}{2}$ %	Replay head tuning
C 2	.04 μ F	150V	V1A grid coupling
C 3	.005 μ F	400V	V1B grid coupling
C 4	.01 μ F	400V	V2A grid coupling
C 5	32 μ F	Elec 275V	HT smoothing 13236/10
C 6	32 μ F	Elec 275V	
C 7	.05 μ F		V2A anode DC blocking
C 8	.04 μ F	150V	Part low frequency attenuator
C 9	620pF	10%	Replay NFB (bass boost)
C10	220pF		Part tone control
C11	470pF	2 $\frac{1}{2}$ %	Record bias feed and record head tuning
C12	4700pF	2 $\frac{1}{2}$ %	Oscillator tuning
C13	3900pF		Oscillator grid drive coupling
C14	.003 μ F	300V AC	Oscillator anode coupling
C15	50 μ F	Elec 25V	V2B cathode bypass 13228/4X
C16	100pF		W1 decoupling
C17	.02 μ F	150V	Level indicator time constant
C18	32 μ F	Elec 300V	HT smoothing 13236/13
C19	32 μ F	Elec 300V	HT reservoir

INDUCTOR AND TRANSFORMERS

Ref	Description	Part No.
L1	Bias oscillator coil	30354/1
T1	Audio output transformer	18313
T2	Mains transformer	18312

SPARE PARTS LIST

Description	Part No.
Cabinet	30403
Connecting lead	30393
Control knobs:	
Volume Control	(clip 45931)
Tone control	
Record/Play	(clip A102635*)
Mechanism control	
Cover (moulded)	18398/3
Fillister head fixing screw for above	SB4F04/N
Head cover	30407
Microphone	30391
Tape deck	30405

Manufacturers . . .

FERGUSON RADIO CORPORATION LTD

GREAT CAMBRIDGE ROAD, ENFIELD, MIDDLESEX

A Subsidiary of . . .

THORN ELECTRICAL INDUSTRIES LTD

Sales Dept. and Showrooms:

THORN HOUSE, UPPER ST. MARTIN'S LANE. LONDON, W.C.2

Service Depots:

LONDON: ELEY'S ESTATE, ANGEL ROAD, EDMONTON, N.18. Telephone: EDMonton 3060

BIRMINGHAM: 24 SHEEPCOTE STREET, 15. Telephone: Midland 5291

MANCHESTER: THORN HOUSE, DERBY STREET, CHEETHAM, 8. Telephone: Deansgate 8484

GLASGOW: 160/162 BATTLEFIELD ROAD, S.2. Telephone: Langside 9251/2/3/4

