

THE MANUAL
OF THE
“FERROGRAPH”
SERIES 420

THE FERROGRAPH COMPANY LTD.
84, BLACKFRIARS ROAD · LONDON S.E.1.



FERROGRAPH MAGNETIC TAPE RECORDER
SERIES 420

CONTENTS

	<i>Page</i>
FOREWORD	7
GENERAL SPECIFICATION	8
Operating Instructions :	
1. Connecting Up	9
2. Loading With Tape	10
3. To Run	11
4. To Playback	11
a. Single channel upper track	11
b. Single channel lower track	11
c. Simultaneous twin channel recording	12
5. To Rewind	12
6. To Record	13
a. Single channel upper track (microphone)	13
b. Single channel lower track (microphone)	14
c. Single channel upper track (radio or gram)	14
d. Stereo (i) microphone (ii) disc	15
e. Special applications	16
f. Two signals on one track (mixing)	16
g. Playing back on one track and recording on other	17
h. Echo effect	17
7. Erase Link	17
8. Brief Stop	18
9. Endless Loops	18
10. Care and Maintenance	20
11. Technical Description	22
a. The mechanical unit	22
b. Circuitry : Power Supplies	26
c. Record amplifiers	27
d. Meter circuit	31
e. Erase and bias supplies	31
f. Playback pre-amplifiers	32
12. Testing and Alignment	35
a. Voltages	35
b. Gain and amplifier equalisation	36
c. Head alignment	37
d. Recording level	38
e. Bias checking	38
f. Frequency response	39
g. Crosstalk	40
h. Signal/Noise ratio	41
i. Wow and Flutter	42

13. Conversion of 422 to 424						43
Appendix A. Operational Fault Analysis	44
Appendix B: Parts List	49
Appendix C. Accessories	58

LIST OF DIAGRAMS AND PLATES

	<i>Description</i>	<i>Fig.</i>	<i>Page</i>
Rear panels	1	9
Tape loading	2	10
Amplifier controls	3	10
Tape deck converted to loop operation	4	20
Loading of loop cassette	5	21
General view	6	23
Underside of tape deck	7	24
Power Unit underside view	8	27
Power Unit top view	9	28
Record amplifier chassis underside view	10	29
Record amplifier chassis top view	11	30
Playback amplifiers underside view	12	33
Playback amplifiers top view	13	34
Track dispositions	14	47
		15	48
Circuit diagram	16	56

"FERROGRAPH"
MAGNETIC TAPE RECORDERS
SERIES 420

FOREWORD

The "Ferrograph" is a very versatile instrument—its applications range far and wide over the fields of science, education, entertainment and industry. Moreover, its simplicity of operation together with its high standard of performance commends it equally to the technically unskilled for whom the recording may be an end in itself, and to the engineer or professional recordist for whom it may be a very important link in a complicated system.

This booklet in consequence must have regard to the widely differing outlooks of all these users, if its object — to enable each to derive the maximum possible benefit from the instrument in his chosen field—is to be fulfilled. Much technical information is therefore unavoidable. At the same time explanations in simple terms are necessary for the benefit of those who have no great knowledge of "Electronics."

In all cases, however, the contents of the succeeding pages will repay careful study as they deal not only with the possibilities of the "Ferrograph" but also with its limitations. As in any well ordered scheme of things, a full understanding of the one is equally as important as the other.

THE FERROGRAPH COMPANY LTD.
LONDON AND SOUTH SHIELDS

"FERROGRAPH" SERIES 420

GENERAL SPECIFICATION

RECORDING MEDIUM	Standard or "Extra Play" $\frac{1}{4}$ " plastic coated tape. On reels up to a maximum of $8\frac{1}{4}$ " dia. (coating inside).
RECORDED TRACK WIDTH ..	0.083" (Head is 0.093" but overlaps tape 0.010")
$\frac{1}{2}$ TRACK WIDTH (PLAYBACK ONLY) ON 424 ..	0.043"
NUMBER OF RECORDED TRACKS	2
PLAYING TIME PER TRACK ..	Large reel 45 mins. at $7\frac{1}{2}$ ins./sec. 1,750 ft. Std. Tape 90 mins. at $3\frac{3}{4}$ ins./sec.
FAST WINDING TIMES	Less than one minute for 1,200 ft. std. tape. (either direction).
FREQUENCY RESPONSE	$3\frac{3}{4}$ ins./sec. 50—10,000 c.p.s. \pm 3 db $7\frac{1}{2}$ ins./sec. 40—15,000 c.p.s. \pm 3 db
"WOW & FLUTTER"	Less than 0.2% at 7.5 ins./sec.
ERASE & BIAS FREQUENCY ..	Approx. 68 kc/s.
INPUT LEVELS, (For full depth recording)	Input 1, minm signal, 2 mV RMS. Input 2, minm signal, 350 mV RMS. Impedances 1 Megohm and 0.5 Megohms respectively.
OUTPUT ARRANGEMENTS ..	Two terminal Jacks (one terminal to chassis).
OUTPUT EACH TRACK	1.0 volts RMS maximum. (output impedance 5,000 ohms approx).
SIGNAL/NOISE RATIO	Unweighted, including hum, 52 db.
TRACK SEPARATION (STEREO) ..	Approx. 40 db.
LOWER TRACK REJECTION ..	On "Mono" application, equal to, or greater than 60 db at 400 cycles.
POWER CONSUMPTION	115 watts.
OVERALL DIMENSIONS	$18\frac{1}{2}$ " x $17\frac{1}{2}$ " x $9\frac{1}{4}$ " high, with lid.
WEIGHT	48 lbs.

OPERATING INSTRUCTIONS

1. CONNECTING UP

The power lead requires a plug appropriate to the house installation, having due regard to the green earth wire.

ENSURE THAT THE POSITIONS OF THE VOLTAGE SELECTOR KNOBS ON THE REAR PANEL CORRESPOND WITH THE SUPPLY VOLTAGE (205-245v models only).

Instrument is energised by switch 12 (Fig. 3) on front panel, meter illumination will come on immediately.

The use of headphones excepted, at least one external amplifier and loudspeaker will always be required.

The sensitivity of this amplifier can be quite low, as the output from the Ferrograph exceeds one volt from a normal recording, *i.e.*, the "pick-up" terminals on the usual AC MAINS ONLY radio set could be used. Ordinary flex can be used for the connection between Ferrograph and external amplifier, and no loading resistor need be used. Indeed, to maintain the full output and the best possible frequency response, it is desirable that the input impedance of the external amplifier should be not less than 20,000 ohms. This of course, is

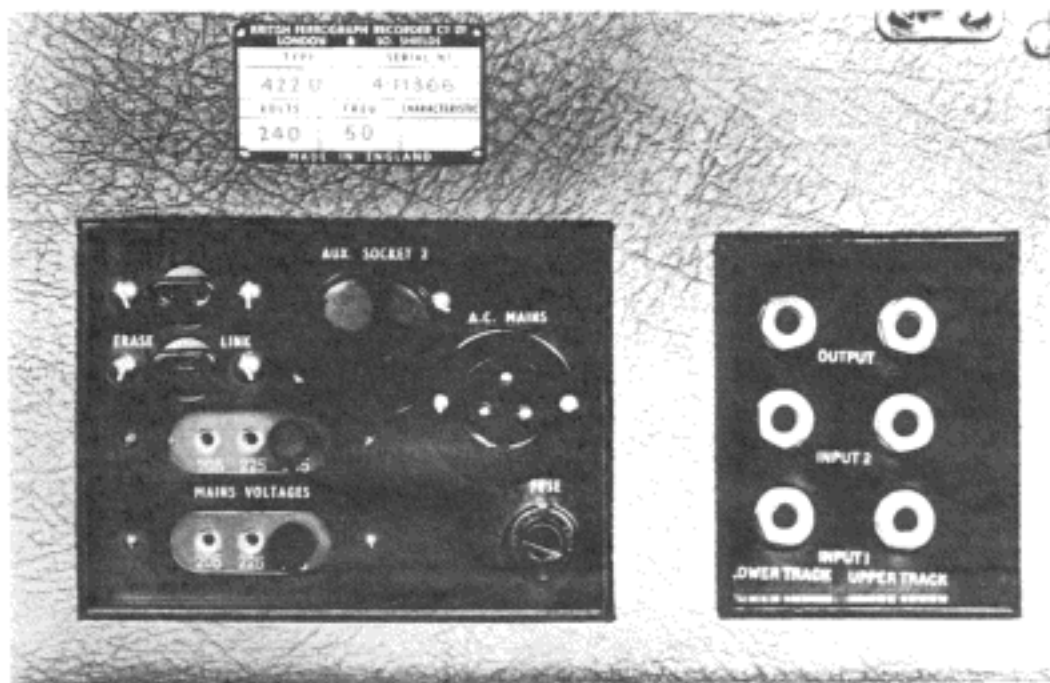

FIG. 1. REAR PANELS

well below the usual figure for practically all amplifiers likely to be encountered. If headphones are used however, these may well be below 20,000 ohms, but due to their basically limited frequency response, the foregoing may be disregarded. Use only one mains "earth" lead for both equipments, to avoid the possibility of hum due to an "earth loop".

2. TO LOAD

Main function switch knob (A, Fig 2.) must be in one of the "fast wind" positions. Open the head cover (G), drop tape between heads, pressure pads and capstan, and position over left hand guide and between right hand guide and auto stop arm as shown in Fig. 2.

Fasten free end of tape in take-up reel by means of the tape grip provided at the reel centre. Take up any slack by rotating the reel, close the head cover and turn the main function switch to the operation desired.

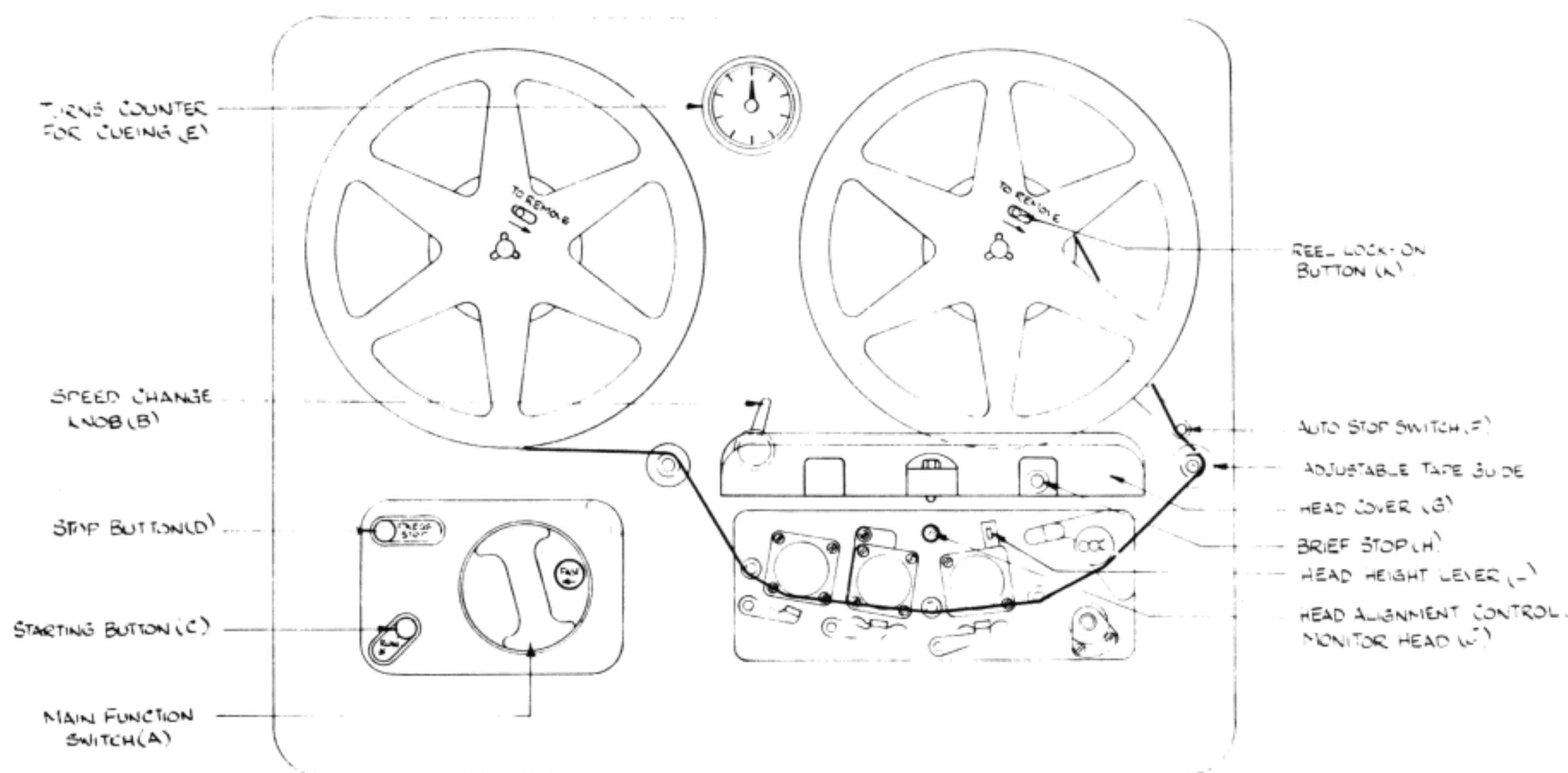

FIG. 2.

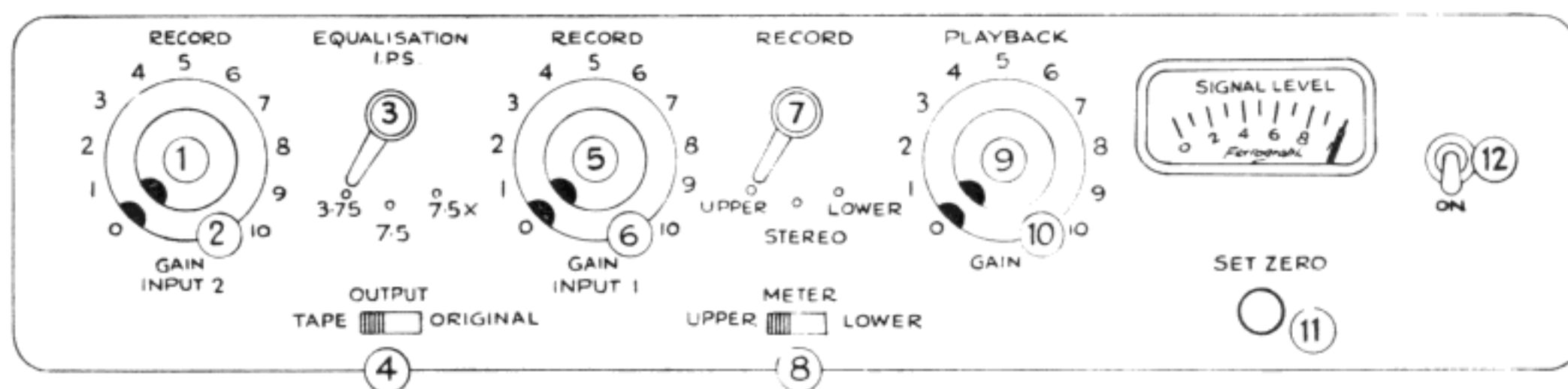

FIG. 3.

3. TO RUN

Select the operating speed required, by the lever knob (B) on the tape deck, check that knob 3 on the front panel (Fig 3) is set to the same speed otherwise the starting button (C) will not "hold in" when pulled towards the bottom left hand corner of the control panel.

NOTE :—The usual position of knob 3 will be 7·5. Position 7·5 X is only used for replaying pre-recorded tapes of European origin (CCIR characteristic).

Pull knob C towards the bottom of its slot, (where it will lock in), to start. Stop, by momentarily depressing the button on the control panel marked "PRESS STOP". (D).

DO NOT ATTEMPT TO CHANGE THE TAPE SPEED WHEN RUNNING AND NOTE THAT, ALTHOUGH THE MAIN FUNCTION KNOB MAY BE TURNED FROM WIND ON TO WIND BACK OR VICE VERSA WITHOUT STOPPING, THE TAPE MUST BE STOPPED TO SWITCH TO RECORD OR PLAYBACK.

If the tape is catching either reel check it can be adjusted to run clear by moving the bobbin guides up or down. Unlock them by twisting top anticlockwise, screw up or down spindle as desired and relock by screwing top and bottom together.

4. TO PLAY BACK

(a) Single channel upper track (standard)

Check that the front panel controls are as follows.

Knobs 1, 2, 5, 6 and 10 fully anticlockwise, *i.e.*, at zero. Knob 9 advanced to say 5 on scale.

Switch 3 to desired tape speed and equalisation.

Switch 4 to "TAPE".

Switches 7, 8 and knob 11 are only effective when recording, and can be in any position when only playback is envisaged.

Finally, check that the lead to the external amplifier is in the upper track output jack at the rear of the Ferrograph.

On starting the tape transport, sound should be heard from the external loudspeaker and the knob 9 should be adjusted, (together with the external amplifier gain control, if necessary), to give the desired listening level.

(b) Single channel lower track

Except for special applications it will be probably only rarely that this facility by itself will be required, however it is only necessary to observe the same procedure as for upper track playback, except that knob 9 will be turned to zero and knob 10 advanced. The lead to the external amplifier should be transferred to the lower track output jack.

NOTE :—On twin track recorded tapes made on a standard recorder such as the Ferrograph model 4A, the lower track will be heard backwards if it is attempted to replay it as above. The correct procedure is to invert the reels and replay it through the upper track channel as is done on a standard instrument.

(c) **Simultaneous twin channel recordings, e.g., Stereo**

For this of course an additional external amplifier and loudspeaker will be required and it should be connected (without a mains earth of its own) to the lower track output jack.

Taking first a pre-recorded twin track stereo tape.

Arrange the loudspeakers at the recommended spacing given by the tape manufacturers. (If none is mentioned, 7 to 10 feet apart is the usual distance).

On the model 424, check that the monitor head lever, (L in Fig. 2), is fully forward, *i.e.*, head is in "down" position.

Check panel controls.

Knobs 1, 2, 5, 6, at zero.

Knobs 9 and 10 advanced to say 5.

Switch 3 to 7.5 for tapes of American origin or with NARTB characteristic. To 7.5 X for tapes of European origin or with CCIR characteristic.

Switch 4 to "TAPE" position.

Run the tape, and adjust knobs 9 and 10, together with the external amplifier gain controls, to the desired output level.

NOTE :—If the external amplifiers have exactly the same amplification, a balanced output should be obtained if knobs 9 and 10 are set to the same dial reading. This will apply over most of the scale but slight individual adjustments may be necessary if their setting is at either end.

The model 424 (not the 422) will also replay $\frac{1}{2}$ track pre-recorded stereo tapes, and the only change necessary from the above is to move the monitor head lever (L) to the "back" position, *i.e.*, head is fully up.

5. TO REWIND

Set the main function switch to the wind back position, next to record. The automatic stop arm will retract from the tape and is therefore inoperative when fast winding, so that it is advisable to remain in the immediate vicinity of the instrument during this short operation.

Start the mechanism in the usual way when the tape will be rewound at high speed. If the playback gain controls (knobs 9 and 10) have been left advanced a high speed garbled sound will result as the tape passes over the monitor head, this is often useful for cueing or place location on the tape, but if undesired one or both knobs should be returned to zero.

The indicator clock will slowly return to the reading it had at the commencement of recording or playback and at this point the rewind may be stopped by depressing button (D).

If the initial point is overrun the direction of the tape run may be reversed without pressing button (D). Simply turn the main function knob to the other wind position when the tape will slow down and reverse direction.

6. TO RECORD

A characteristic common to all recording is that the erasing head on the instrument will be operating throughout this particular process. It is not necessary to load with virgin tape—any reel containing unwanted recordings can be used. The old recording, on the track in operation, will be removed as the new programme material is applied, but the other track will be left unaffected.

(a) Single channel upper track (microphone)

Model 424 only. Head lever (L) in forward (head down) position (APPLIES FOR ALL RECORDING).

Plug microphone into input 1, UPPER TRACK, jack on rear panel.

Check that the front panel controls are as follows :—

Knobs 1, 2, 5, 6, 9, 10, are at zero. These settings pre-suppose no monitoring of the signal as in general, it is only possible to monitor microphone recording off the tape with headphones. If the external amplifier and speaker are used, acoustic feedback occurs in the form of a continuous howl. If headphone monitoring is desired the external amplifier should be unplugged and replaced by a pair of headphones (impedance—any value 30—4,000 Ω). Knob 9 should then be advanced to approximately "8" on its scale.

Knob 3 to speed desired.

Switch 4 to "TAPE".

Knob 7 and switch 8 to "UPPER" (IMPORTANT :—NEVER OPERATE SWITCH 7 WITH THE MAIN DECK SWITCH ON "RECORD", OTHERWISE THE RECORD HEAD WILL VERY LIKELY BE POLARISED, NECESSITATING THE USE OF A HEAD DEFLUXER.)

Turn the main function switch to RECORD and set needle of peak level meter to zero by knob 11.

It is useful at this juncture to set also the turns counter (E. Fig. 2) to zero by means of its centre knob, so that the tape can be wound back to this point after recording.

With the microphone working (speech or music, etc., played into it at the level which will be used), advance knob 5 until the meter needle is swinging up to 8 on its scale.

Start the tape transport.

Adjust the monitor headphone level (if used) by knob 9.

After recording, stop, reconnect the external amplifier if necessary, wind back, and turn main function switch to playback.

(b) Single channel lower track (microphone)

Plug microphone into input 1 LOWER TRACK, jack on rear panel.

Check that the front panel controls are as follows :—

Knobs 1, 2, 5, 6, 9, 10, are at zero. For monitoring, plug headphones into OUTPUT LOWER TRACK on rear panel and advance knob 10 to, say, 8 on its scale.

Knob 3 to speed desired.

Switch 4 to "TAPE".

Knob 7 and switch 8 to "LOWER".

The procedure then follows that for upper track microphone recording except that knob 6 is used to set the recording level.

When playing back, regulate gain by knob 10. (Change headphones for ext. amplifier).

(c) Single channel upper track (radio or gramophone)

NOTE :—The following instructions relate to radios and gramophones made to work on AC MAINS ONLY. In general, AC/DC apparatus must be approached with care, as either extra capacitors in the leads, or an isolating transformer are usually required, and the unskilled are advised to leave this to a qualified technician.

Most radio sets have extension speaker sockets brought out at the rear which provide a useful take-off point for a signal. The connections from these can be made by a length of twisted flex to an unshielded jack plug.

Check that if one of the external sockets is connected to chassis, the lead from it connects to the body of the jack plug. (The longer connection blade under the jack cover). A better method, but one involving some knowledge of radio set circuitry, is to take the output for injection into the "Ferrograph", immediately after the receiver's detector stage. This avoids using the receiver's output stages, which are unnecessary so far as the Ferrograph is concerned, and avoids the distortion and hum sometimes associated with such stages.

Here, the signal will normally be of lower level, and may be taken into the INPUT 1 socket of the recorder if adequate gain is not provided at INPUT 2. This might also apply in the case where a tuner unit is used instead of a complete set, the main criterion being that if knob 1 is turned to a scale reading of 10 and peak level is not attained on the meter, it is necessary to change the lead over to INPUT 1, reset knob 1 to zero and advance knob 5.

Similar considerations apply to recording from gramophones, and it is always better to take the signal from an associated amplifier or pre-amplifier (because of the tone controls provided) rather than direct from the pick-up.

For either radio or gramophone recording therefore, the procedure is :—

Connect to input 2, UPPER TRACK.

Check that the front panel controls are as follows :—

Knobs 2, 5, 6, 10, are at zero.

Knob 3 to speed desired.

Knob 7 and switch 8 to "UPPER".

Turn the main function switch to "RECORD" and set the needle of the peak level meter to zero by knob 11.

With the radio or gramophone working, advance knob 1 until the needle is swinging to 8 on its scale. If now, knob 9 is advanced and switch 4 set to "ORIGINAL", the signal will be heard before recording. Note counter "E" reading. Start the tape running, and change switch 4 to "TAPE", when the signal will be heard off the tape. In this way a check can be made of the quality of the original and recorded sound.

After the recording, stop, wind back to the original counter reading, and turn the main function switch to playback.

For LOWER TRACK recording the same procedure would apply except that the panel knob settings would be :

Knobs 1, 5, 6, 9 at zero.

Knob 3 to speed required.

Knob 7 and switch 8 to "LOWER".

Adjust recording level with knob 2 and monitor level with knob 10.

Plug signal into input 2 and changeover external amplifier to output LOWER TRACK

(d) Stereo (both channels together)

It should be noted that, when they are recorded simultaneously, the "crosstalk" between channels is of the order of 40 db. This is adequate for stereo, but if it is attempted to record two *entirely different* signals at the same time, some breakthrough between the tracks might be audible. Recording the same signals one at a time, (knob 7 on "upper" or "lower"), gives negligible crosstalk because no bias is then present on the track not being recorded.

(i) Stereo recording (microphone)

This requires two separate microphones or a special two unit stereo microphone. With the former, results will vary with the separation, and angle of the individual microphone heads (if ribbon type), and usually some experimenting will be necessary. With the stereo microphone, the only variable is the positioning of it, relative to the sound to be recorded, the other factors being pre-determined.

To make a recording, the procedure is similar to that described for single channel working, except that both tracks will be working together.

If headphone monitoring is envisaged, each earphone should be connected separately to each output jack on the rear panel.

The panel controls should be set initially as follows :

Knobs 1, 2 at zero (also 9, and 10, if no monitoring).

Knob 3 to speed desired.

Switch 4 to "TAPE".

Knob 7 to "STEREO".

Turn the main function switch to "RECORD" and set peak level meter to zero (check with switch 8 on UPPER and LOWER).

With the microphone working, and switch 8 on "UPPER", advance knob 5 until the meter is swinging to 8 on its scale.

Set switch to LOWER and advance knob 6 for the same result. Note counter (E) reading and start tape running.

(ii) Stereo recording from disc

Once again, most of the notes concerning disc recording on single channel apply, use two external amplifiers and speakers for monitoring, and SWITCH 4 will compare "ORIGINAL" and "RECORDING" on both channels.

(e) Special Applications

It is recommended that the preceding pages are studied before any of the following applications are attempted, as in general, they are combinations, or simple variants of standard recording techniques.

(f) Recording two signals simultaneously on one track (mixing)

The first important thing is to note that one signal must be 400 mV (or more) and the other between 2 and 50 mV. If the latter is greater than 50 mV, it can easily be reduced by a simple potentiometer arrangement, but this must be done before injection into input 1.

Once suitable signals are available it is simply a matter of injecting the larger into INPUT 2 and the smaller into INPUT 1.

Considering the upper track, set the recording levels of each signal independently by means of knobs 5 and 1, pulling out the jack plug carrying the other signal (or switching it off), as each one is set.

Once the levels are set recording can follow in the usual way.

(g) Playing back on one track and recording on the other

This is done by combining the instructions for single channel playback and recording on different tracks, and it is possible to copy a recording from one track on to the other by linking the output and input 2 jacks of either track by a double-ended jack plug lead. (can be ordinary flex).

This can be applied to paragraph (f) using one previously recorded track as one signal and say a microphone as the other.

(h) Echo effect

An echo effect may be obtained by connecting, say, the upper track OUTPUT to the upper track INPUT 2. The signal source *e.g.* a microphone, would then be plugged in INPUT 1. It is of great assistance in setting the controls if a pair of headphones be also connected across the OUTPUT, *i.e.*, in parallel with the lead to INPUT 2. Now proceed as for a normal single channel recording with headphone monitoring (PARA. 6 (a)) but slowly advance knob 1, which will bring in the echo. It will be found that a careful adjustment is required to avoid multiple echoes or even feedback instability which occur with too great a setting of knob 1.

Changing the speed to 3.75 will give a much greater delay in the echo.

7. ERASE LINK

At the rear panel of the instrument will be found a small shorting plug in a socket marked "ERASE LINK". This has a two-fold purpose.

Firstly, by the removal of the plug, it ensures that the recordings cannot be accidentally erased. This it does by severing the connection between the erasing oscillator output and the deck. It will be found of great value where the recorder is to be used by the relatively unskilled, for the purpose of repetitive playback only of valuable recordings.

The second function of this link is to provide a means of interjecting spoken commentaries into existing recordings without the clicks and sudden discontinuities which usually occur when this is attempted by merely turning to "Record", interjecting and switching back to "Playback".

The object of the present system is to provide a gradual but complete fade out of the previously recorded material, a smooth insertion of the new material, followed by a gradual restoration of the original. This is achieved by plugging into the erase link socket, a new plug,

to the pins of which is attached, by a foot or so of twin lead, a 1,000 ohm wirewound rheostat of 4 watts dissipation and with a logarithmic characteristic. (Available from the Company on request).

Having then carefully noted by time interval or scale marking, the positions at which the interjection is required, the recorder is started, carefully set for the new recording level in the "Record" position, but with the variable resistor mentioned, set to the maximum position.

Running in this way, no erasing will take place.

As soon as the appropriate point is reached, the variable resistor is slowly rotated to its zero resistance position. At this point, both the erase and the bias will be fully operative, the old material will have been faded out and the new can be inserted. When finished, the resistor should be slowly rotated once more to its maximum position.

It goes without saying of course, that it is not necessary to use this method only when an interjection is required. It can readily be used to delete unwanted portions of a recording in an unobtrusive manner.

8. BRIEF STOP

When making a series of short recordings, it may be noticed that a slight click is put on the tape at the start and finish of each recording. Normally this is of little consequence and can be ignored. It can be eliminated however, by the use of the brief stop, the operating button of which is shown in Fig. 2. The action of depressing this, pushes the pinch roller off the capstan and holds the tape against the right hand guide peg, stopping the movement of the tape immediately. The housing of the button has a standard Leica camera thread, so that a shutter release cable can be screwed on for remote operation if desired.

9. ENDLESS LOOPS

The "Ferrograph" finds many applications in science and industry where special problems present themselves. Some of these do not require long recording sequences in the normal way but instead, an endless band of tape for continuous presentation of data or for continuous recording. A loop of a few minutes duration is usually adequate in such circumstances and the cassette attachment about to be described (which is an optional extra) caters for a maximum of 4 minutes at 7.5 i.p.s. or 8 mins. at 3.75 i.p.s. Under the continuous recording conditions referred to above, any activity capable of translation into an electrical phenomenon within the frequency and phase shift limitations can be monitored, so that the last few minutes are always

on record. In this way the instrument can be made to act as a memory loop and if necessary, its memory can be shortened to a matter of a few seconds. Monitoring for fault conditions is an obvious application of the facility, as immediately a fault occurs it can be arranged that either manually or automatically the deck is shut down so that afterwards on playback, the conditions leading up to the establishment of the fault can readily be traced.

When making the conversion to endless loop operation, the take-up and magazine motors must be disconnected so that they do not revolve. This can be done by breaking the link between the tags marked O & 5 on the rear tagboard of the deck behind the take-up motor.

Before fitting to the deck it will be necessary to load the cassette with the required amount of tape. It is not wise to exceed the maximum running time so, bearing in mind that at 7.5 i.p.s. the tape velocity is 37½ ft./min. and at 3½ i.p.s. 18½ ft./min., the appropriate length should be cut from a reel of well aged ACETATE BASED tape. On no account should tapes with either PVC or POLYESTER (MYLAR) backing be used, otherwise sticking and binding between the turns in the cassette will occur.

The three screws and their spacers around the periphery of the cassette should be removed and the small peg inserted in the way shown in Fig. 5. The start of the tape should be passed from the outside through to the inside of the cassette over the fourth roller counted in a counter-clockwise direction from the peg, and the winding should proceed in a conventional "coating inside" manner over the peg, the purpose of which is to ensure that when it is removed, the tape is left very loosely wound. It must of course be removed before any attempt is made to operate the equipment and the peripheral spacers should also be replaced. The illustration shows the cassette being wound on a conventional cine-film winding attachment which provides a convenient means of carrying out the operation. After winding, the ends of the tape should be spliced together, leaving a loop of approximately 18 inches.

In operation the tape will be pulled out of the inside of the cassette and by virtue of the inter-turn friction, the whole mass of tape will revolve easily on the anodised surface and the rollers, and wind itself again on the outside.

The cassette is attached by means of captive screws to the hank bushes rivetted to the deck under the magazine reel. Fig. 4 shows it in position. As there should be little or no tape tension between the capstan and the cassette when the endless loop is running, the auto stop cannot be used. To stop it swinging back and preventing the start button holding in, a small elastic band (¼ inch) should be looped under the lower cheek of the right hand bobbin tape guide (*i.e.* between it and the deck) and over the post on the end of the arm.

When first run after loading on to the instrument, the winding tension will adjust itself automatically to the correct inter-turn friction and the length of the free loop will vary accordingly. Normally it will increase in length as the tape tightens up and after the tape has been running for some few minutes, the tape can then be re-spliced at the original join to bring the free loop within the confines of the deck. It must not be made too small as otherwise the tape may bind in the cassette. Fig. 4 shows a typical loop in operation.

Where the loop is being loaded with previously recorded material, obviously the length cannot be shortened haphazardly and therefore to take up the loop length, the splice must be undone and further turns taken round the cassette before re-joining.

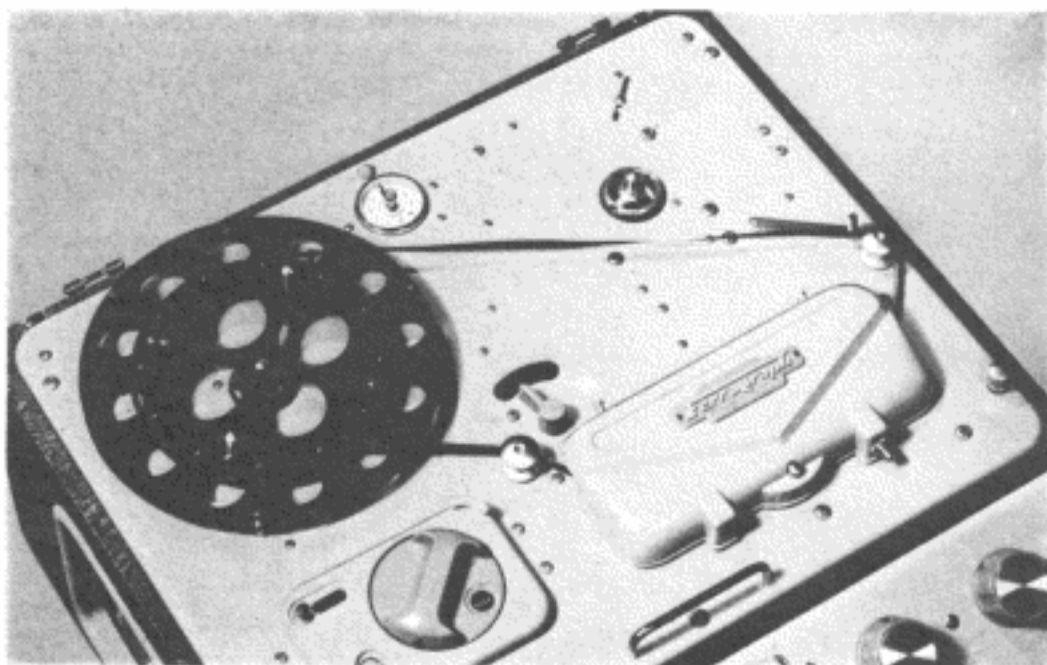

FIG. 4. TAPE DECK CONVERTED TO LOOP OPERATION

10 CARE AND MAINTENANCE

Little actual maintenance is necessary with the "Ferrograph" beyond the periodic removal of dust and dirt from the head assembly. After a time a deposit from the tape will form on the working surface of the heads and unless removed, may impair the frequency response. To reach the heads it is only necessary to open the head cover box. A small brush is provided for the cleaning operation and it should be gently used. It is best applied while the pressure pads are deflected to their full extent with the fingers, the gate mechanism of course being open.

The record and reproducing heads are very vital parts and their working faces should be treated with great care. After a time they will acquire a high polish, and this is a very desirable condition to be maintained. Never allow any abrasives to come into contact with the head faces and never approach them with steel tools which may have become magnetised. Furthermore never attempt to remove the cylindrical cans of the heads themselves, as the gap setting or the alignment of the head faces may be upset with serious results.

The capstan also requires great care to see that its surface remains undamaged. Here too tape coating material and dirt may accumulate causing "wow", or the tape to pull but weakly. New tape quickly leaves a fine deposit so that periodically, or whenever it is suspected of causing poor tape transport, the capstan surface should be wiped with a dry cloth. If allowed to accumulate for too long, a VERY LIGHTLY damped cloth may be necessary.

Do not carry out this operation with the capstan running as there is grave danger of the cloth becoming caught and causing damage to the capstan.

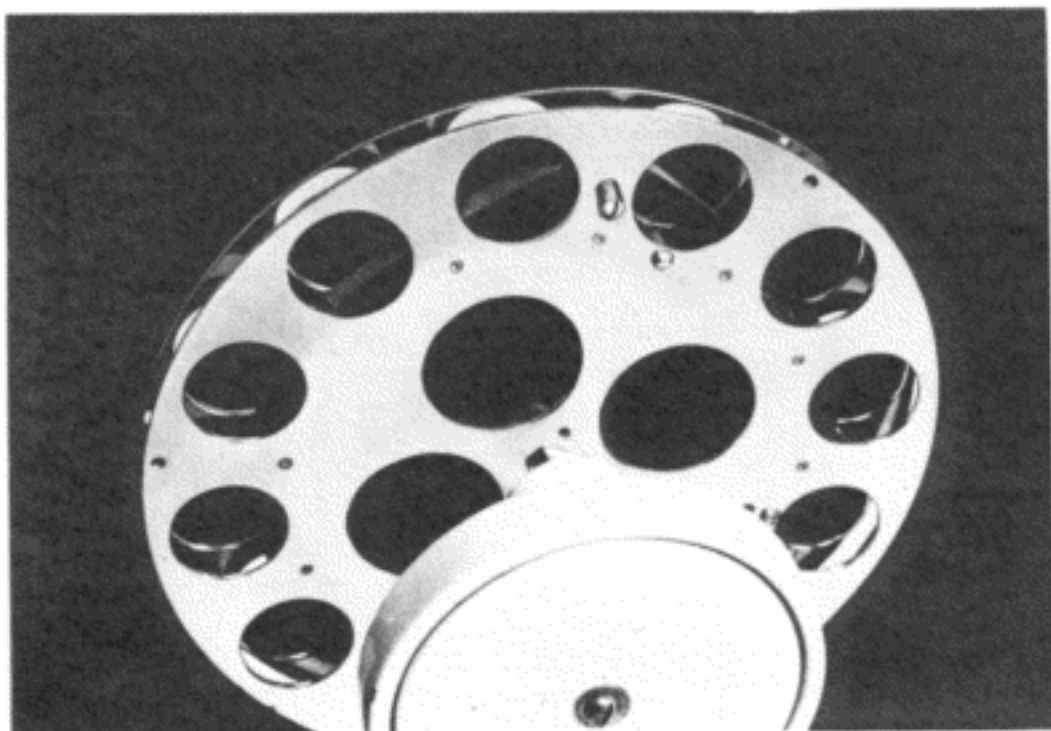

FIG. 5. LOADING OF LOOP CASSETTE

All rotating parts of the tape deck are fitted either with self oiling bronze bearings or grease packed ball races. The latter require no regular attention and the former should run for approximately 1,000 hours before any oil need be applied. To do this, a few drops of Aeroshell fluid number 3 should be introduced into the top and bottom bearings of each motor with a suitable 'dropper', taking great care not to splash either the brake shoes or the idler wheels. If difficulty is experienced in obtaining this particular oil, it can be supplied in a small container as an accessory.

If necessary due to excessive noise or stiffness, a trace of oil can be applied from time to time to the sliding members of the gate mechanism and the pinch roller bearing, but under no circumstances should oil or grease be allowed to come into contact with the neoprene face of the capstan.

TECHNICAL SECTION

The following pages are entirely technical in nature and devoted to a description of the main design features together with test and alignment procedures in case of need.

II. DESIGN DETAILS

(a) The mechanical unit

The mechanical unit is wholly contained on the hinged top deck of the instrument. Three motors are employed. One, running counterclockwise when energized, takes up the tape after having passed through the capstan assembly; the second, running clockwise when energized, rewinds the tape after recording. During the record and playback functions this motor is partly energized to maintain a small back tension on the tape. The sole function of the third motor is to drive the capstan and flywheel assembly. It is a split phase capacitor type induction motor with sufficient reserve of power to make it relatively insensitive to small changes of applied voltage or load, and its speed therefore, within certain limits, is controlled only by the frequency of the mains supply.

This motor, running clockwise viewed from its spindle end, carries a stepped pulley, against either step of which a neoprene rimmed idler wheel drives a heavy flywheel. Rigidly coupled to this flywheel is the capstan proper which has a brass bush to which is bonded the loaded neoprene traction surface.

The assembly is mounted on greased angular contact ball races, rendering any regular lubrication unnecessary.

Three separate heads are used on the model 422, these are the two track erase head X4 followed by the two track stereo record head X5 and the two track stereo monitor or playback head X6.

On the model 424 the only change is the substitution of a quarter track playback head X7 for X6.

The erase head is mounted rigidly on the base plate but small shims are usually employed underneath for exact adjustment of its height.

The record head is screwed to a small plate which pivots on two cone pointed screws on its centre line, one at the front and the other at the rear. These screws fit into tapped holes in the plate and are fixed by 6 BA locknuts, they are used to determine the height setting of the record head. The plate and head may be rocked over a small angle by a screw in the front right corner. This is to ensure that the gaps in the upper and lower track sections of the head are exactly at right angles to the tape path, thus falling into line with other instruments, and guarantees that recordings made with it can be played back without any loss of the high frequencies which would occur if the gaps in the record and playback heads were at different angles.

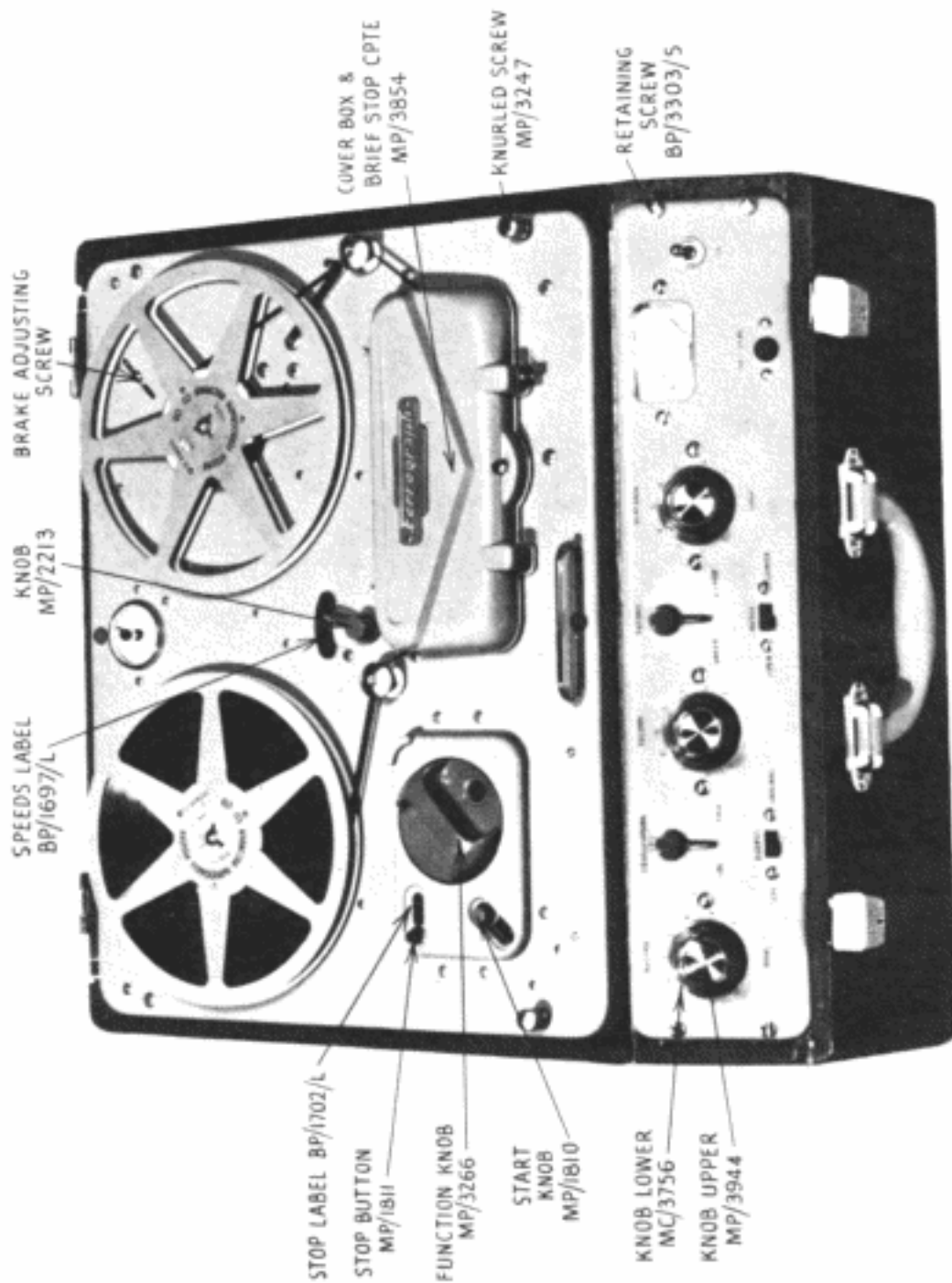

FIG. 6 GENERAL VIEW

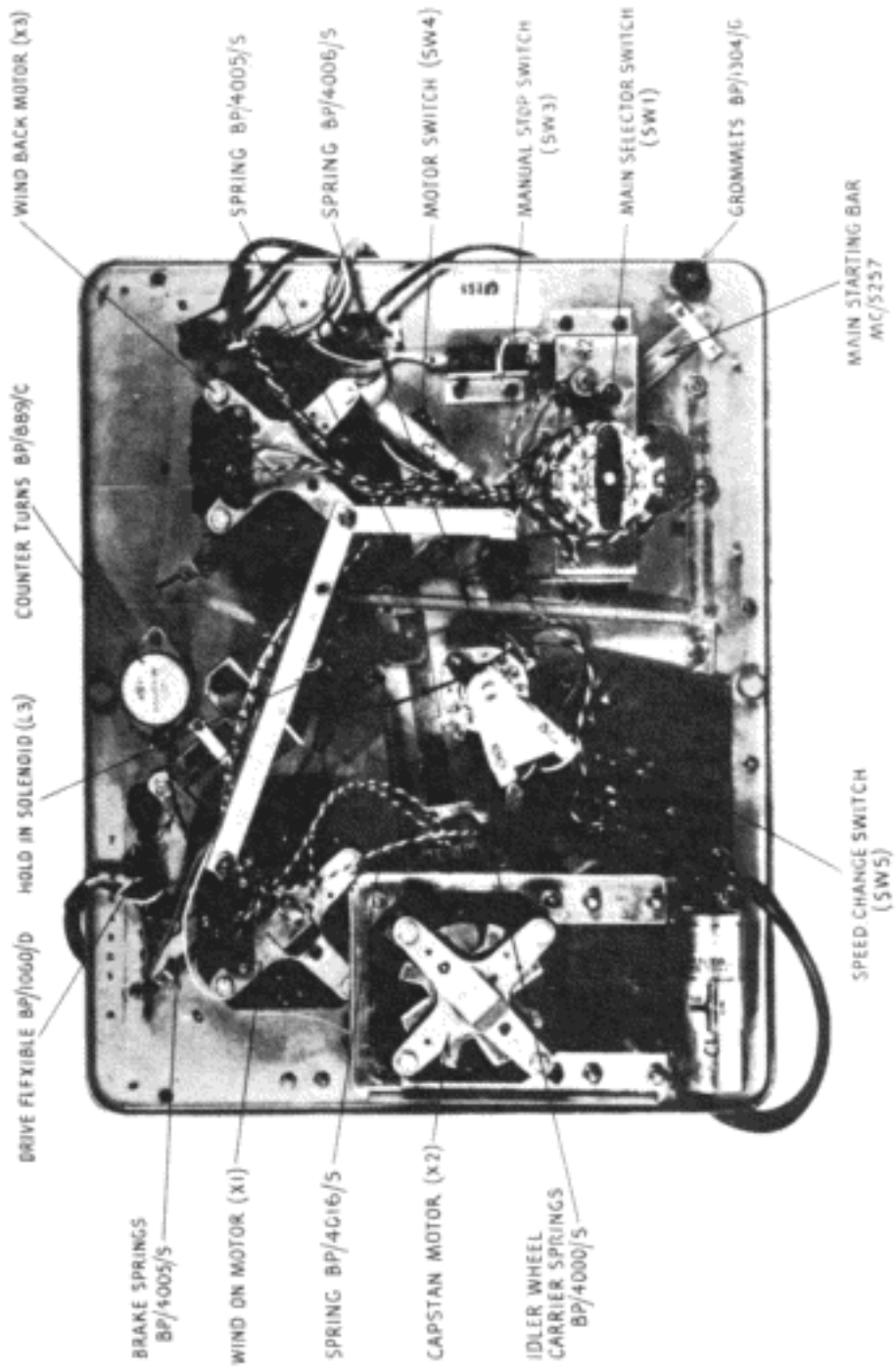

FIG. 7. UNDERSIDE OF TAPE DECK

The playback head X6 is mounted on a diecast body which is also pivoted to permit its gap alignment with the tape. The relevant adjusting screw has a large knurled knob and is located to the left and rear of the head. Also at the rear is the head height lever which is not used on the model 422 and locked in position by a clamping screw and plate. On the model 424, by moving the lever back, the head may be raised by approximately 0.035" to align (in the horizontal sense) with quarter track pre-recorded tapes, the vertical gap alignment remaining unchanged. The relative positions of the heads and the track dispositions are shown in Figures 14 and 15 and it will be noted that with only 0.030" separation of the erase head sections, any recorded tapes from other half or quarter track recorders can be completely erased.

To the right and rear of the head assembly is pivoted the arm of the automatic stop switch; at the end this has a short vertical rod which rests lightly across the tape between the right hand bobbin guide and the reel centre. When the supply reel is empty and the end of the tape comes off, or if the tape were to break or the take up motor stop, this arm swings over under light spring tension and by means of a simple switch under the deck shorts out the solenoid (L1).

During the fast winding operations the arm of the auto stop is automatically pulled clear of the tape and is therefore inoperative, but as winding on and back are of short duration and invariably under supervision the action of the auto stop is then unimportant.

Starting and stopping of tape transit is accomplished through the main operating bar (Fig. 6) the knob of which protrudes through the small panel at the lower left of the deck. Pulling this arm diagonally towards the front of the equipment operates the main motor switch (SW3), across which is a capacitor (C1) for interference suppression, and at the same time pulls the brakes off the reel brake drums. This arm is held in the "on" position by the hold-in solenoid (L1) which is energized by rectified current from the special valve heater supply from the mains transformer. To stop the tape transport this solenoid is shorted by the push switch (SW5), or by the contacts of the auto stop switch previously referred to, which allows the arm to return under spring tension. This switches off the motors and applies the brakes to the reel drums. Sections of the speed change switch on the tape deck and the equalisation switch on the amplifier panel are also connected across the solenoid in such a manner that unless the same speed is set on each, the solenoid will be shorted and, thus prevents making a recording with the wrong pre-emphasis (equalisation). The brakes are so arranged as to have self wrapping properties, that is to say that they have their maximum effect on the reel which is being pulled and very little on that which is energized. During rewind therefore a much greater braking torque is applied to the take up reel so that spillage of tape is avoided, and similarly during "wind on" and normal running to the magazine reel.

The main operating arm is also linked with the capstan pinch roller and the idler wheel of the flywheel drive, so that these are only brought into engagement with their respective rotating parts when the mechanism is "on". This has been done to provide an instantaneous start and stop of tape transit, and also to prevent the temporary appearance of indentations in the neoprene parts which may be caused if these members are left in

engagement under spring tension for prolonged periods. On switching off, these members are knocked out of engagement.

The change of connections of the heads and motors necessary during the various operations is carried out by the ceramic wafer switch (SW1). One wafer of this looks after the motor supplies whilst the lower controls the oscillator HT supply and the feeds to the record head. Linked to this switch by a cam arrangement is a lever which deflects the pressure pads from the heads, and the pinch roller even further from the capstan, during the fast wind operations. The cam itself is interlocked with the main operating bar so that the main function knob cannot be turned when the tape is running on record or playback. It can be turned however between rewind and wind on without stopping the tape. As the pressure arms and pinch roller are withdrawn in the "wind" positions of the main function knob, it is then that loading the tape should be carried out.

Most of the connections from the deck are taken down through a pair of multiway cables ending in octal plugs and sockets which engage with similar plugs and sockets on the amplifier and power unit. The exceptions are the two leads from the stereo playback head (coded green for lower track and red for upper), the two leads for the stereo record head (coded yellow for lower track and black for upper) and a lead carrying bias supplies which plugs into the power unit chassis.

(b) Power supplies

A full theoretical circuit is given in Fig. 16. With regard to the actual wiring, all models are the same except for the primaries of the mains transformers TR3 and TR4 but due to the different mains voltages for the various types, the motors and associated capacitor and resistor have different designations.

As will be seen from the circuit diagram, valves in the first, *i.e.* low level, stages of both playback and record pre-amplifiers, (V1, 2, 4, 6, 8) have their heaters fed with DC to reduce possible hum generation to a minimum. Valves associated with the oscillator, peak level meter and output stages, being less critical in this respect, have AC heater supplies. Direct current for the valve heaters is obtained from a pair of silicon rectifiers MR2, MR3 in an orthodox full wave circuit and is smoothed by R82 and C50, ending at 12.6 volts which can be applied directly to the double triodes.

The tape deck solenoid, in series with a 100 ohm resistor (R77), is also connected across this DC supply, with the junction of the two connected to chassis. When the stop button on the tape deck, or the auto stop is operated, the solenoid is shorted out and R77 prevents a short circuit of the DC power supply.

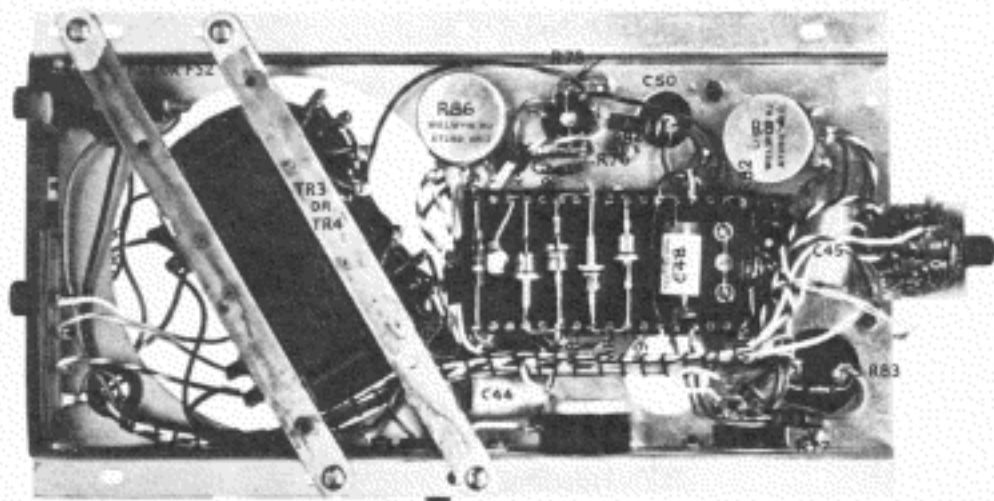

FIG. 8. POWER UNIT UNDERSIDE VIEW

The valves V3, V5 and V7 have their heaters (6.3V connection) wired in series across one half of the 19-0-19 volt AC secondary, whilst V9 plus a series resistor R84, and the two meter illuminating lamps LP1 and LP2 plus their series resistor R90, are across the other half.

250 volts DC for the pre-amplifiers is supplied by four silicon rectifiers (MR4, 5, 6, 7) in a bridge circuit across the HT secondary winding of the mains transformer. It is smoothed by resistor R83 and capacitors C49 and C51. The HT supply for the oscillator and meter valves is taken off before the smoothing resistor.

(c) Record amplifiers

The two record pre-amplifiers are situated on the front amplifier chassis, *i.e.* below the control panel, and they are of identical construction for upper and lower tracks.

Referring again to the circuit diagram and dealing with the upper track record pre-amplifier, jack JK1 (or input 1) is connected directly to the grid of one triode section of V1 and has an impedance of 1 megohm.

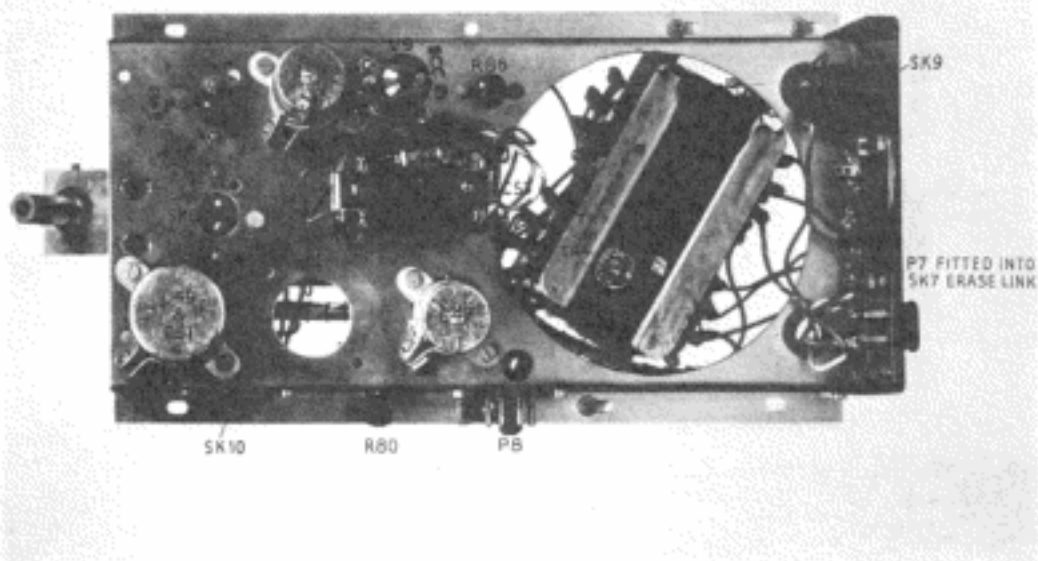

FIG. 9. POWER UNIT TOP VIEW

It is important to note that this is intended for low level sources, and signals in excess of 50 mV will overload the valve, with consequent distortion. The first triode section V1a is RC coupled to the second section V1b, and resistors R7 and R8 provide some negative feedback between them, materially improving the overall linearity and distortion.

From the anode of V1b the signal passes via C7 to the input 1 gain control R10, and from there via R11 to the grid of V2a. R11 prevents the grid of V2a being at chassis potential when R10 is in its minimum position, and R14 performs the same function with respect to the input 2 gain control R13, which is also connected to the grid of V2a. This ensures that signals into inputs 1 or 2 are virtually unaffected (maximum variation 2 db) by the relative positions of the gain controls, wherever these may be. R17 and C10 between the anode of V2a and chassis provide approximately 3 dB of bass boost, and its anode load resistor is in two parts R15 and R16. This is to provide a tap to feed a certain amount of the signal via C9 into the grid of the playback pre-amplifier output valve for the purpose of comparison with the signal off the tape (original tape switch).

The HT supply to V2a and the corresponding lower track valve V2b is decoupled via R12 and C8.

From the anode of V2a the signal passes to the recording output valve V3a and also via the meter switch to the meter valve V5. Treble boost during recording is provided by the resonant circuit L2, C15 across the cathode resistors of V3a. This is changed by a

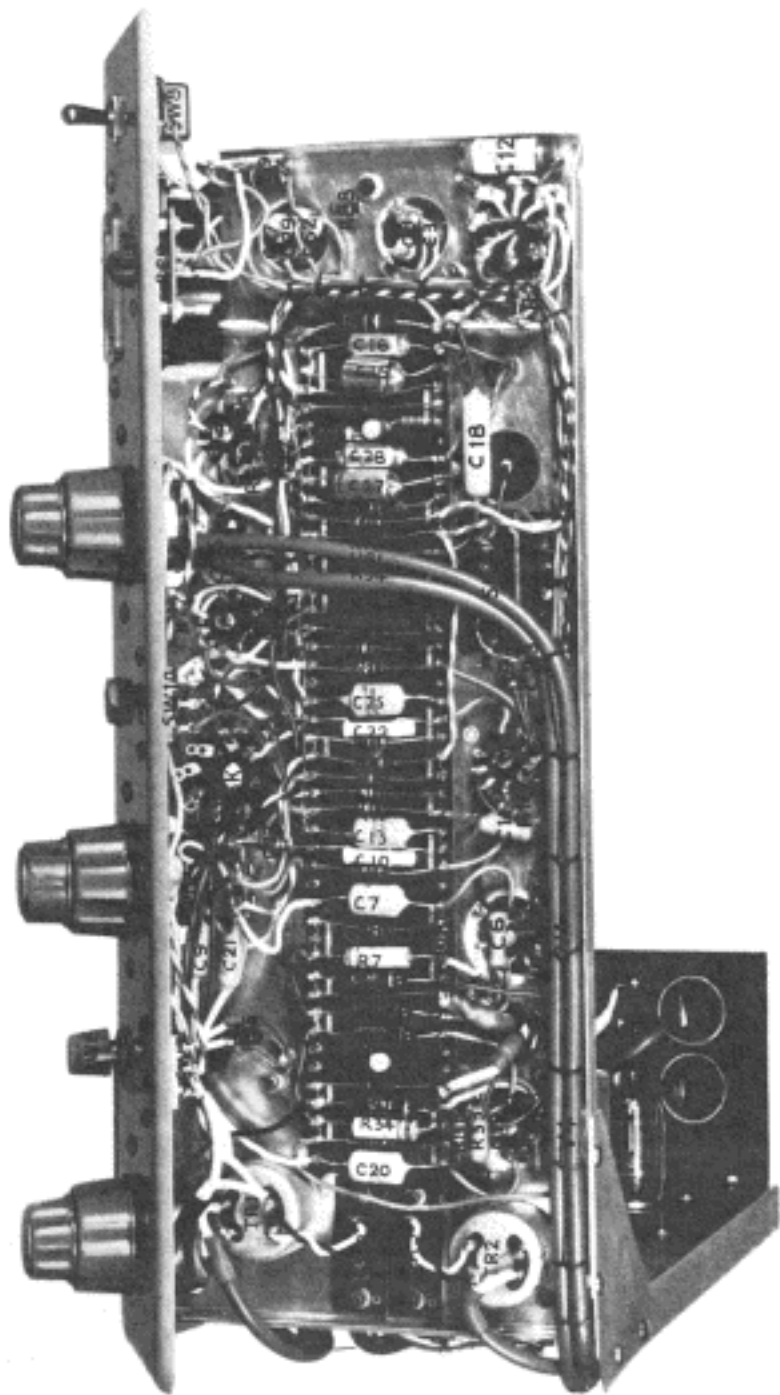

FIG. III. RECORD AMPLIFIER CHASSIS UNDERSIDE VIEW

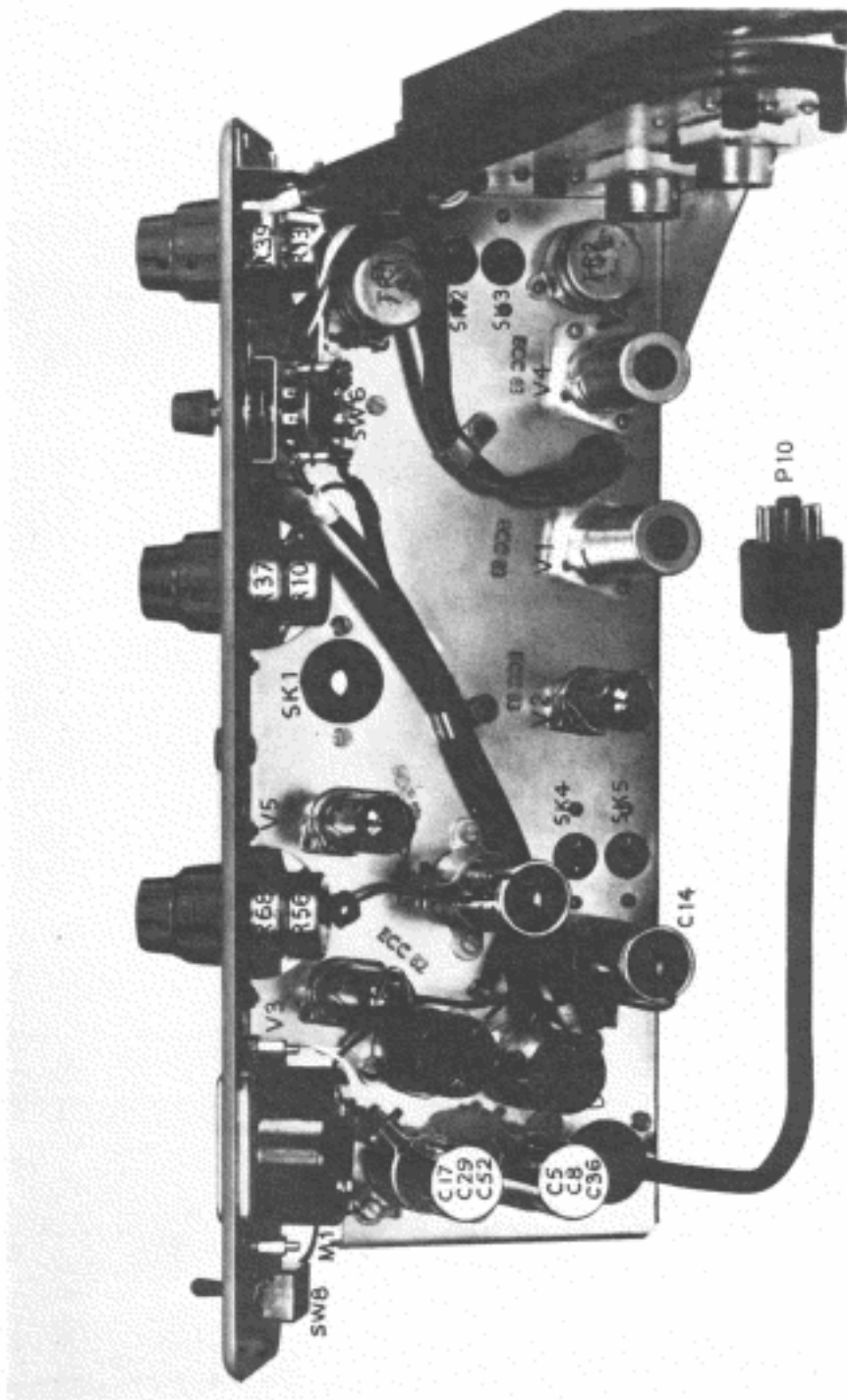

FIG. 11. RECORD AMPLIFIER CHASSIS TOP VIEW

switch to a different value for each tape speed. The signal is conducted to the head via C14 and SK4. From P4 the signal is led via a section of the main tape switch to the upper track section of the record head X5.

(d) Meter circuit

Considering the meter circuit, the signal arrives, via R25 and C24, at the grid of the first section of V5 which is connected as a cathode follower to provide a low impedance source for charging C18. R25 is included so that, in conjunction with R26, the meter sensitivity can be set correctly. From the cathode of V5a the signal is rectified by MR1 and charges the reservoir capacitor C18, the resultant voltage (negative with respect to chassis) being applied to the grid of V5b. The peak level meter proper M1 is a 1mA DC full scale deflection backward reading millimeter *i.e.* the pointer is at the right hand side for zero current and deflects from right to left. V5b is cathode biased by the resistor network R24, R29 and R89 so that at zero signal input 1 mA is passed through M1, and the pointer deflects full scale which is marked as zero. Exact adjustment to this zero mark can be made by R29, the meter zero potentiometer on the front panel. The arrival of a signal at the input to V5 causes a negative voltage to appear at V5b grid, reduces the anode current and deflects the meter pointer. An advantage of this method is that the meter cannot be damaged by an excessive signal as the effect is to reduce the current through it to zero for apparent full scale. The meter scale, although having 10 arbitrary divisions, is substantially linear from zero to nine, and "8", designated additionally by a red line, corresponds to peak recording level. The meter is illuminated by two miniature bulbs which also serve as an indication that the equipment is switched on, the meter itself however only operates on the "record" position of the main switch, this is done by switching its HT supply on at the same time as that for the oscillator.

(e) Erase and Bias supplies, Oscillator

The bias and erase voltage is generated by a double triode V9 located on the power unit chassis. The circuit is that of a conventional push pull oscillator with the primary of the coil L4 tuned by capacitors C54, C46, C53 in series. One side of the secondary of L4 is connected to chassis and the other (output) side goes via the "erase link" SK7 to the track selection switch SW9. The pole of the switch section to which it goes also has connected to it a variable resistor R86 marked "bias equalise". The other end of this resistor goes to another switch section which connects it to chassis in the upper or lower track (mono), but not in the stereo, position of the switch. The function of R86 therefore is to compensate for the reduced load on the oscillator and maintain the bias voltage at its correct value when each track is recorded independently.

In order to avoid circulating currents leading to some degree of cross coupling, both leads to the unused section of the erase head X4 are disconnected when recording single track. It was found necessary though to disconnect only one lead of the bias supply to the unused track of the record head X5.

To assist in tracing the bias and erase feeds, it may be stated briefly that the upper track bias supply is from SW9 via R80 and pin 4 on P8 and SK8 then through tag 3 on the deck, C4 and to the UT winding on X5, the other end of this head winding being permanently connected to ground.

The upper track erase head section is supplied via C44 and pin 5 (P8 and SK8) then from tag 2 on the deck to X4. The other side of the winding is led via deck tag 1, pin 8 on SK8 and P8 to SW9, where it is switched to chassis in the upper track and stereo, but left disconnected on the lower track, position.

The lower track bias supply is via R87, SK6 and P6, deck tag F and C3 to the LT winding on X5.

The lower track erase supply goes again via SK6 and P6 and deck tag E to one end of the winding, then from the other via deck tag 7 pin 3 on SK8 and P8 to a section on SW9 where it is connected to chassis on every switch position except upper track record.

(f) **Playback pre-amplifiers**

As both playback pre-amplifiers are of identical construction, the following description of the upper track will serve for both.

The signal from the monitoring head X6 arrives via P2 and SK2 at the primary of the input transformer TR1, the secondary of which is connected to the grid of the first section of the double triode V6. This triode section is RC coupled (R50, C32 and R53) to the other, and between the two is the playback equalisation network. This works on the negative feedback principle *i.e.* part of the signal is fed back over C33, R54, R92 and R52 to the cathode resistor R49 of the first triode.

A section of SW6 is used to vary the resistance in the feedback line to compensate for different recording characteristics, and capacitors C30 and C31 are used together across R49 for extra treble boost at 3 $\frac{1}{2}$ i.p.s.

Using the cathode of V6a tapped into the junction of R51 and R49 provides adequate bias with a moderate value of R49.

It may be noted at this point that there is a minor difference in the upper and lower track amplifiers in that the latter has an extra capacitor C55, this is a compensating feature for the extra capacitance of longer screened leads (due to the different location of each amplifier).

The series resistors R1 and R74 between the cathodes of V6a and V8a are for the purpose of cancelling spurious induced signals between the sections of the stereo monitor head (crosstalk reduction).

Following again the path of the equalised signal in the upper track playback pre-amplifier, it passes through C34, and if SW7 is in the "tape" position, to the playback gain control R56. From there it goes to the grid of the cathode follower output triode V7a (half of V7). The actual output is taken from the cathode resistor R59 through C35 and R60 to the output jack.

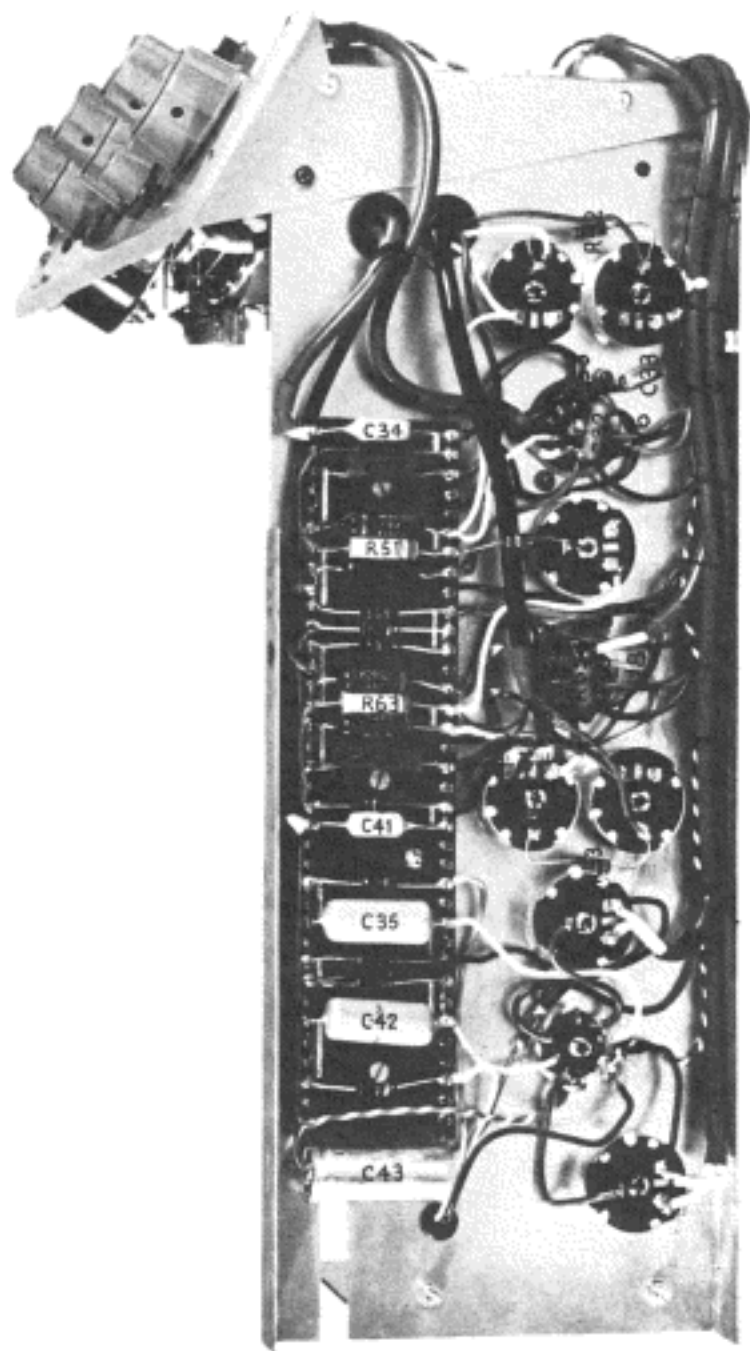
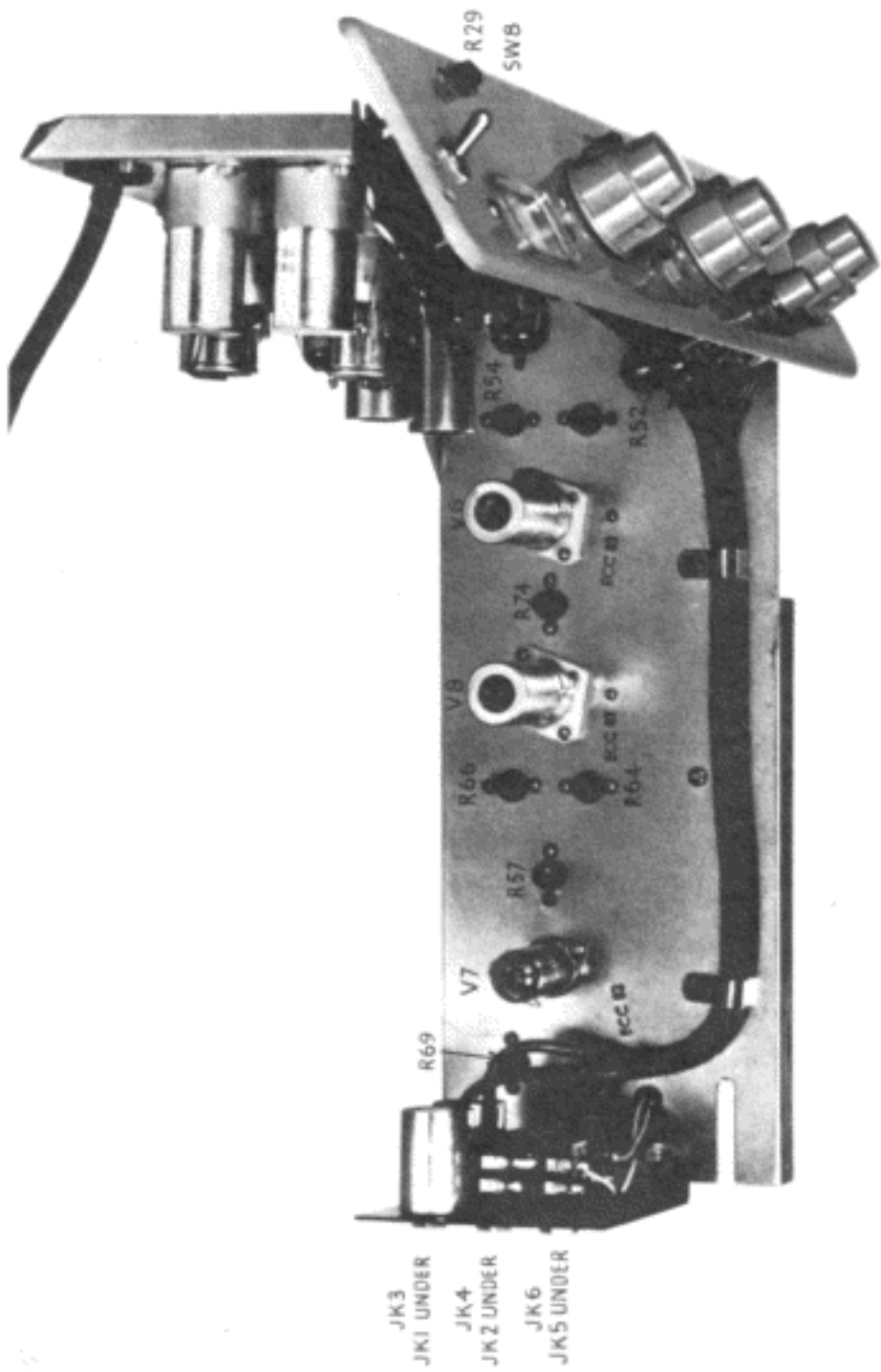

FIG. 12. PLAYBACK PRE-AMPLIFIERS UNDERSIDE VIEW



JK3
JK4 UNDER
JK5 UNDER
JK6

FIG. 13. PLAYBACK PRE-AMPLIFIERS TOP VIEW

12. TESTING AND ALIGNMENT

Where a major component has been replaced it may be necessary to carry out certain re-alignment of the pre-amplifier networks. This section is consequently included for the benefit of the Service Engineer. It details the whole testing and setting procedure.

It cannot be too strongly emphasised however that indiscriminate readjustments should not be made against these instructions without cause, as prior to leaving the factory the "Ferroglyph" will have been carefully set up with a great deal of specialised equipment. The fact that there may be slight discrepancies between the readings obtained and those shown below does not mean that adjustments are necessarily called for.

(a) Voltages

AC Heater Voltage (P10 on circuit diagram between Pins 2 & 7) .. 19v RMS

DC Heater Voltage (P10 on circuit diagram between Pins 3 & 7) .. 12.6v

DC Voltage across Tape Deck Solenoid 6.4v

DC Voltages Associated with Valves :—

VALVE No.	ANODE 1 (Pin 1)	ANODE 2 (Pin 6)	CATHODE 1 (Pin 3)	CATHODE 2 (Pin 8)
V1	70	90	—	1.5
V2	120	120	1.0	1.0
V3	140	140	35	35
V4	90	70	1.5	—
V5	270	270	—	2.5
V6	80	90	—	1.0
V7	230	230	11	11
V8	90	80	1.0	—

AC Voltages

245V or 110V applied at relevant frequency. Measured on the appropriate AC range of an Avometer model "8" 1000 ohms/volt.

PLAYBACK OR RECORD	422U	422A	422E
	424U	424A	424E
	245v 50c.p.s.	117v 60c.p.s.	110v 50c.p.s.
Voltage across capstan motor capacitor	520v	300v	220v
Voltage across capstan motor input socket . .	245v	110v	110v
Voltage across take up motor input socket . .	150v	80v	80v
Voltage across rewind motor input socket . .	100v	47v	47v

Measured with a valve voltmeter.

68 kc/s bias volts, measured at pins of record head X5 . . 14 - 20V RMS

NOTE : Rear Two Pins for Upper Track (UT)

Front Two Pins for Lower Track (LT)

The correct values for the head will be found on a small label on the underside of the deck, generally at the centre left edge.

68 kc/s erase volts, on each erase head section (pin connections the same as the record head) . . 27 - 30V RMS

(b) Gain and amplifier equalisation

As the gain of the playback pre-amplifiers varies considerably with frequency (due to equalisation) and only 1.0 volts are available at the output jacks, it is recommended that simple resistive attenuators of 100:1 and 1000:1 be used for the various inputs and at different frequencies. The first could consist of 100 K ohms and 1 K ohms and the second of 1 M ohms and 1 K ohms resistors.

With these attenuators, 1.0 volts can be applied across them from the audio oscillator and provided the correct attenuator is used, the output will be of the same order, this can be seen more clearly in the following table.

The tests should be done with all gain controls on the front panel fully clockwise, and to carry out the first it will be necessary to remove the four screws holding down the front panel, prop up the deck, remove the large screw holding the side amplifier, and loosen the clamping piece on the rear input panel. The amplifier can then be lifted up to expose the underside.

This is necessary since the input impedances of TR1 and TR2 are extremely low and it is more convenient to measure the gain of the playback amplifier from the secondary windings of these transformers instead of the more accessible head sockets.

PRE-AMP	ATTENUATOR	INPUT POINT	FREQUENCY	GAIN	POSITION OF SWITCH 4 (Fig. 2)
Playback	1000 : 1	Grid of V6a or V8a	40 c/s	1000	Tape
Playback	100 : 1	Grid of V6a or V8a	1000 c/s	75	Tape
Playback	100 : 1	Grid of V6a or V8a	15 kc/s	50	Tape
Record	1000 : 1	Input 1 Jack	1000 c/s	1000	Original
Record	10 : 1	Input 2 Jack	1000 c/s	5.6	Original

The above will check the recording amplifier up to the last stage, if this is suspect, the output voltage can be measured at the head sockets SK4 or SK5 with the head leads unplugged. To do this, inject a 1000 cycle signal into input 2 and advance the gain control to register "8" on the peak level meter. 6 volts should then be present at the head socket. At 15 kc/s, with switch 3 (Fig. 2) on 7.5, this voltage will rise to roughly 20, whilst on 3.75 at 10 Kc/s it should be 25.

When the head is plugged in, the voltage developed at the head socket will drop to 60mV, although then the oscillator valve will have to be removed to prevent bias volts masking the reading.

All the above figures, including those in the table, are average values and the readings obtained on individual instruments may vary somewhat from them, this applies in particular to the playback amplifier where the gain is dependent upon the setting of the equalisation controls.

The following tests apply to both the 422 and 424 models, but in the latter case the playback head should be in the "down" position for all of them.

(c) Head alignment

Before leaving the factory the gaps of both the record and playback stereo heads are set exactly at right angles to the tape. This alignment is done by means of a master tape and, as explained in the technical description, is vital both for the high frequency performance of the instrument itself, and to ensure that its recordings will be fully interchangeable with those made on other instruments.

For these reasons, the azimuth settings of the record and playback heads should not be interfered with under normal circumstances, but in cases where some derangement has occurred, the re-alignment will require a test tape carrying a constant level recording of a high audio frequency *e.g.*, 10 kc/s at 7.5 i.p.s.

This should be played back using the upper track amplifier and the playback head azimuth screw (Fig. 2) adjusted to give a maximum output, which can conveniently be indicated on an AC voltmeter across the output jack. To adjust the record head azimuth, remove the test tape and substitute a reel of standard recording tape. Inject a 10 kc/s signal into input 1 or 2 and turn to RECORD. Set the recording level to HALF THE FIRST DIVISION on the meter and run the tape at 7.5 i.p.s. Now adjust the record head azimuth by means of the front right hand screw in the head base plate until a maximum output is obtained from the playback head.

(d) Recording level

The peak recording level corresponds to the maximum signal which can be applied to the recording head network for a given amount of distortion on playback. On these models this level will be set so as to produce not more than 3% total distortion on peaks. The process is as follows :—

Turn to RECORD, then with all record gain controls fully anticlockwise, adjust the recording level meter accurately to zero and inject a source of 1000 cycles into input 2 upper track at a level of approximately 0.5 volts. Connect a wave analyser or distortion meter to the upper track output jack and advance the upper track input 2 record gain control until the recording level meter reads 8. Run the tape at 7.5 i.p.s., adjust the playback gain control and measure the total distortion ; it should be between 2.5 and 3%. If it is not, vary the recording level to obtain the correct figure, this will then give a reading other than 8 on the meter, and it will be necessary to re-adjust the latter to 8. This may be done by changing the value of the resistor R26 (circuit diagram).

The same check may be applied to the lower track channel in a similar way but of course the meter cannot be altered again if there is any discrepancy in the record level/distortion relationship, however this is extremely unlikely.

Where a distortion meter is not available, some idea of the total distortion can be obtained by applying the output to the Y plates of an oscilloscope, at the same time connecting the X plates direct to the output of the audio oscillator.

Because of phase differences, an ellipse can be obtained on the screen of the cathode ray tube and the regularity of this ellipse used to give an indication of the distortion present. Some experience is normally necessary to relate 3% distortion to the modified shape of the ellipse, so that it is not possible to give definite guidance beyond stating that the ellipse should only be slightly distorted on the "major axis" parts of the curve.

(e) Bias checking

If a record head has been replaced or, if after very long use it is suspected that the head requires a different value of bias, a test for optimum bias may be instituted as follows :

Unscrew the tape deck holding down screws, hinge it back so that the two bias potentiometers on the power and oscillator unit are readily accessible and prop it up in this position. Dealing first with the upper track, connect a valve voltmeter across the two

rear pins of the stereo record head and an AC voltmeter to the playback output jack or the output of an amplifier connected to the same.

Turn to RECORD and, with the record gain controls fully anticlockwise, align the meter needle accurately on zero by means of the zero set control. Inject a constant 200 cycle tone at a level of roughly half a volt into input 2 and advance the corresponding gain control to give a level of 6 on the meter. Run the tape at 7.5 i.p.s. and adjust the playback gain to give a convenient reading on the AC voltmeter. Now vary R80 to obtain a maximum output, all other parameters remaining fixed. The value of bias read on the valve voltmeter at this setting of R80 may be taken as the optimum for the upper track channel and the particular tape in use.

The procedure may be repeated for the lower track, plugging into the corresponding inputs and outputs and connecting the valve voltmeter to the two front pins of the stereo record head. Adjust R87 (Figs. 8 and 9) for the lower track bias.

Having fixed the bias voltages, the oscillator load equalising resistor R86 should now be set. This is done by varying R86 to keep the bias voltage constant when SW9 (knob 7 in Fig. 3) is moved from "stereo" to "upper" in the case of the upper track or "stereo" to "lower" in the lower track bias case.

Note :—In cases where the bias is changed appreciably from the original settings, it will be necessary to re-check the frequency response curve obtained with the instrument's own recording. Due to the small variation in bias requirements on the majority of tapes available, it should not in general be necessary to re-adjust the bias when different makes are used.

(f) Frequency response

Checking the overall frequency response completely at 7.5 i.p.s. would involve six separate tests covering the full frequency range. These are :—

1. Upper track playback using an NAB test tape
2. Lower track playback using an NAB test tape
3. Upper track playback using a CCIR test tape
4. Lower track playback using a CCIR test tape
5. Own recording upper track
6. Own recording lower track

As there are two separate recording amplifiers and two playback pre-amplifiers, most faults which may develop will be confined to one unit at a time and once this is identified it can be treated individually, without the necessity of going through the whole test procedure. The complete setting up is carried out as follows :—

The playback pre-amplifier must be aligned first, using a pre-recorded NAB or CCIR test tape.

An AC voltmeter with a level response between 30 and 16000 cycles *e.g.*, a valve voltmeter, should be connected across the upper track output. If an instrument sufficiently sensitive to read the small voltages involved ($\frac{1}{2}$ volt) is not available, an external amplifier with a linear frequency response can be used. For the upper track response, set SW6 (3 in Fig. 3) to "7.5" for NAB and play back the test tape. Advance the gain control to give a convenient reading on the output meter at 1000 c/s for reference purposes, then adjust the potentiometer R54 (Fig. 13) for the same reading at 10 kc/s. All frequencies on the test tape should then be within ± 3 db of the 1000 c/s figure.

Repeat for the lower track but adjust R66 instead of R54. As the difference in the NAB and CCIR characteristics is compensated for by moving SW6 to 7.5X, it is only necessary to do this before checking the upper and lower track in a similar manner when playing back a CCIR test tape. R54 and R66 should be set on one characteristic and thereafter not touched again.

To check the frequency responses obtained from the instrument's own recording amplifiers, and taking the upper track first, the procedure is :—

Turn SW9 (7 in Fig. 3) to "upper" and inject a 1000 c/s constant tone into input 2, turn to RECORD and set the recording level AT HALF THE FIRST DIVISION on the meter scale *i.e.*, a very low level. Start the tape running and again advance the playback gain control to give a convenient reference level on the meter connected to the playback output. Now record a series of tones at different frequencies between 40 and 15000 c/s and note their meter readings, these should all be within ± 3 db of the reference level. Turn SW9 and the meter switch to "lower", changeover the input and output connections and repeat the process for the lower track. Some adjustments may be made to the frequency response if necessary by varying the high frequency pre-emphasis. This is done by changing the value of C16 (upper track) or C28 (lower track) over a small range. The bass response may similarly be altered by varying R17 (upper track) or R43 (lower track) over a range of 150 K ohms to 270 K ohms.

Frequency response at 3.75 I.P.S.

Own Recording. This is the same as the 7.5 i.p.s. process on each track, except the range of frequencies will be from 50 to 10,000 cycles. Take 1000 c/s as the reference level and adjust the playback equalisation by means of R52 (upper track) or R64 (lower track) (Fig. 13). These potentiometers should be adjusted to give the most level response possible over the range. If required, the recording high frequency pre-emphasis may be altered by means of a change in value of C15 (upper track) or C27 (lower track).

(g) Crosstalk

This term relates to the amount of the signal on one track which is picked up by stray coupling, etc., on the other. It varies, dependent upon whether both channels are recorded together or one at a time, being greater in the former instance. Because the order of the

crosstalk is between 1/100 and 1/1000 of the signal recorded on the other track and in the latter (monophonic) instance can be comparable in level with background noise, some ancillary equipment is necessary for its measurement.

In addition to the usual external amplifier, a calibrated attenuator up to 80 db and a bandpass filter to eliminate hum and h.f. hiss are recommended and they should be connected between the playback output and a suitable AC meter.

To measure the crosstalk with SW9 (7 in Fig. 3) in the stereo position, record a 400 cycle tone at peak level on the upper track at 7.5 i.p.s. With the attenuator set to give 60 db loss, adjust the gain control to give a convenient reading on the meter, and leave it set in that position.

Now invert and transpose the tape reels to bring the signal on to the lower track. Turn the main function switch to PLAYBACK and run the tape. Switch the attenuator to obtain the same meter readings as before, when the difference in the attenuator readings should be approximately 40 db.

For crosstalk in the single track application, turn SW9 to "upper" and proceed exactly as before except that the initial setting of the attenuator should be 80 db. The end result should be a figure of 60 db.

If the crosstalk is worse than the stated figure, the setting of R74 (Fig. 13) should be checked by playing back with the deck propped up and adjusting R74 for a minimum breakthrough from the lower track to the upper.

Also, if either of the heads has to be changed, or the original assembly altered in any way, the height setting of the heads should be checked to ensure that they are accurately aligned. With the model 422, approximately 0.010" of the upper and lower track laminations should be visible above and below the top and bottom edges of the tape respectively *i.e.*, the tape should be centrally disposed on both heads. This is most easily checked by pulling back the relevant pressure arm with the fingers whilst the tape is running. With the model 424 the foregoing applies to the record head, but the playback head should be raised to the "up" position by moving the lever backwards when the top edge of the head laminations should be level with the top edge of the tape.

(h) Signal to noise ratio

The unweighted signal to noise ratio quoted in the specification is the ratio of the RMS noise from the erased tape plus the hum content, compared with the RMS signal output from a fully recorded tape playing back at 3% distortion.

To measure it, the same ancillary equipment used in the crosstalk test can be employed except for the filter, which is omitted. Record a 1000 cycles tone at peak level on the upper track at 7.5 i.p.s. With the gain control fully clockwise and 60 db of attenuation, adjust the gain of the external amplifier to obtain a convenient meter reading. Reduce the record gain to zero and adjust the attenuator for the same meter reading as before, the difference should be 52 db or greater.

The principal factors affecting the signal noise ratio are hum and high frequency noise. If the latter appears excessive, de-polarising the record and playback heads with a suitable head demagnetiser should be tried first. Valves and anode and cathode resistors in the low level stages which have deteriorated are other possible causes.

The position of the mumetal "wing" on the end of the playback head pressure arm is of vital importance to a low hum level and normally it should not be disturbed. If occasion demands however, the 8BA clamping screw can be loosened slightly and the angle of the "wing" adjusted for minimum hum with the motors running. The only precaution necessary in adjusting this is to ensure that the pressure pad contact area is not adversely affected.

Another source of hum may arise in connecting up, if two mains "earths" are used (see Para. 1) and care should also be taken to maintain a respectable distance between the instrument, especially the left hand side where the playback pre-amplifiers are located and any large power transformers or chokes which may be associated with external amplifiers, test equipment, etc.

When switching on the motors there should not be too great a difference between the hum reading then obtained and that with the motors stopped as this would indicate that hum bucking is taking place *i.e.*, that some hum was being injected in anti-phase to that arising from some other part of the equipment. The object should be to align everything for minimum pick-up and in cases where a motor has been changed, reversing the mains input sockets on individual motors can be tried.

(i) **Wow and flutter**

The only reliable method of checking "wow" and "flutter" is by instruments specially designed for the purpose. These fall broadly into two categories, one where the "wow" and "flutter" components are read together or separately on meters as an RMS "wow" and "flutter" factor, and the other whereby the frequency modulation component on the recorded carrier is fed after discrimination to a high speed pen recorder which indicates both the peak "wow" and "flutter" factor and its nature and frequency. In the absence of a suitable measuring instrument, a rough guide can be obtained by using an oscilloscope connected to the output as described in the section on RECORDING LEVEL.

If a 1000 cycle note is recorded and monitored, the rate and degree to which the axis of the ellipse changes should be observed, thereby indicating the instantaneous phase differences between the stable signal from the audio oscillator and the fluctuating signal from the tape. Some "wow" and "flutter" is of course inevitable; it is, as with distortion, once again a matter of estimating the degree, and here it should be emphasized that even the extremely low figure of 0.1% can be clearly distinguished on a 1000 cycle constant tone, whereas it would be virtually impossible to detect in music reproduction.

The causes of "wow" and "flutter" are many and various and any of the components in the tape transport mechanism can contribute to it. Beyond keeping the capstan and

pinch roller driving surfaces clean, or changing a worn pinch roller or neoprene idler wheel in the field, however, its proper rectification is a task for the manufacturer, or an officially appointed agent with full servicing facilities.

13. CONVERSION OF MODEL 422 TO 424

The only essential difference between these models is in the type of playback head fitted and to convert from one to another involves changing this head. However, due to the special feature of vertical head movement on the 424 which requires a careful adjustment sequence, and also the advisability of checking the complete frequency response and gap alignment after conversion, the operation should not be undertaken lightly.

To effect the change, first remove the two screws from the base of the FP16 playback head and gently withdraw it from its holder in the diecast body, preserving any spacing shims which may be under the head. Next remove the screw which holds the small brass plate (stamped 422 only) the square nut underneath will drop inside the flywheel and can be retrieved from there. The head height lever (L, Fig. 2) will now be free to move back in its slot and raise the brass sleeve to which the head is screwed. Screw the FR28 head in position after inserting a 0.015" bakelite spacing shim between it and the base. The next operation is setting the head at the correct height with respect to the tape, and of ensuring it is moved the correct distance by the lever. At one corner of the diecast body underneath the deck, will be found a 2BA "Allen" screw with a nut locking it in position, at the end of this screw is a smaller diameter pin offset from the centre which engages in a slot in the brass sleeve to which the head is screwed. Turn the screw with a 2BA wrench until the head will rise no more, usually a quarter of a revolution will suffice.

Now position the tape across the face of the head as it would be when running and check that the top edge of the laminations projects at least 0.010" above the top edge of the tape. If it is not high enough to do this, insert another shim beneath the head. Now turn the 2BA Allen screw until its end pin contacts the bottom of the slot and then continue turning so that the head descends until the top edge of the laminations is level with the top edge of the tape. Tighten up the nut until the screw is locked in that position.

Note : It is most important that the end pin is contacting the bottom of its slot when tightened otherwise the full vertical head movement will not be obtained.

Finally, check that the head moves smoothly up and down as the head lever is operated.

After changing heads as described, inspect the pressure pad to ensure it is contacting the head surface over the gap region.

It will also be necessary to re-adjust the head gap alignment and probably the position of the mumetal "wing" for minimum hum (see previous paragraphs).

APPENDIX A
OPERATIONAL FAULT ANALYSIS

FAULT	POSSIBLE OPERATIONAL CAUSE
1. Instrument will not start No meter illumination.	Fuse blown (see Fig. 1). Mains lead or plug faulty. Mains Selector knobs loose or missing.
2. Motors start but starting switch will not lock in.	Tape not supporting auto stop arm ; check loading (Fig. 2). Setting of amplifier equalisation switch different to that of deck speed selector knob.
3. Tape slips or "wows".	Dirty capstan or accumulation of tape deposit on pinch roller. Pinch roller spindle dirty. Bad splice in tape sticking in guides or heads. Tape catching on reel cheeks due to incorrect adjustment of bobbin guides. Oil or grease on idler rim.
4. Known, well recorded tape will not play back but tape drives.	Panel switch on "original". Tape incorrectly positioned in head section Piece of splicing tape detached and left over playback head face. Correct gain control not advanced. Output jack in other track socket.
5. Tape plays back with poor frequency response.	Accumulation of foreign matter or tape coating over playback head gap. Playback and record head gaps not in line. (Check record head before adjusting).
6. Pre-recorded quarter track tape appears to play backwards.	Playback head in "down" position. (Head height lever forward). Applies to model 424 only.
7. Pre-recorded twin track stereo tape plays with reduced output on the lower track.	Playback head in "up" position. Applies to model 424 only.

Appendix A—*continued*

FAULT	POSSIBLE OPERATIONAL CAUSE
8. In recording position tape erases but will not record.	Input plug not properly inserted or in wrong socket. Appropriate gain control not advanced. Microphone cable faulty.
9. Will not record or erase.	Track selector switch (7 in Fig. 3) incorrectly set for track in use.
10. Records, but incompletely erases previous recording.	Adhesions of coating, etc., over erase head gap or pieces of splicing material stuck to working face.
11. Records weakly.	Tape coating outside instead of inside.
12. Hum recorded on tape. (Check by changing speed, if hum is recorded, its frequency will be halved).	Microphone in hum field (also matching unit). Microphone transformers or leads insufficiently screened or too long if a crystal microphone is being used. Microphone leads or stand not properly earthed to microphone or in contact with mains leakage paths.
13. A short whistle is recorded at the end of the passage.	Winding back is commenced too quickly after recording <i>i.e.</i> pause momentarily (1 sec.) after turning to wind back before running the tape.
14. Tape runs at one speed but not at the other.	Idler carrier spring broken. Idler wheel circlip missing and wheel has "run off".
15. Tape slows up or stops on Wind back or Wind on.	Reel motor bearing out of alignment making spindle tight. Push reel carriers sideways from various directions until they can be spun freely by hand with the brakes off.

Appendix A—*continued*

FAULT	POSSIBLE OPERATIONAL CAUSE
16. Take-up reel carrier appears to run hot, especially compared to wind-back motor.	It is normal for the take-up reel carrier to feel hot to the touch. Because the wind-back motor runs at a lower voltage, the effect is less with it.
17. Tape winds on unevenly especially on wind on or wind back.	"Bobbin" guides incorrectly set for height. Tape in use has stretched non-uniformly and is concave or wavy, leading to odd layers piling on at different heights.

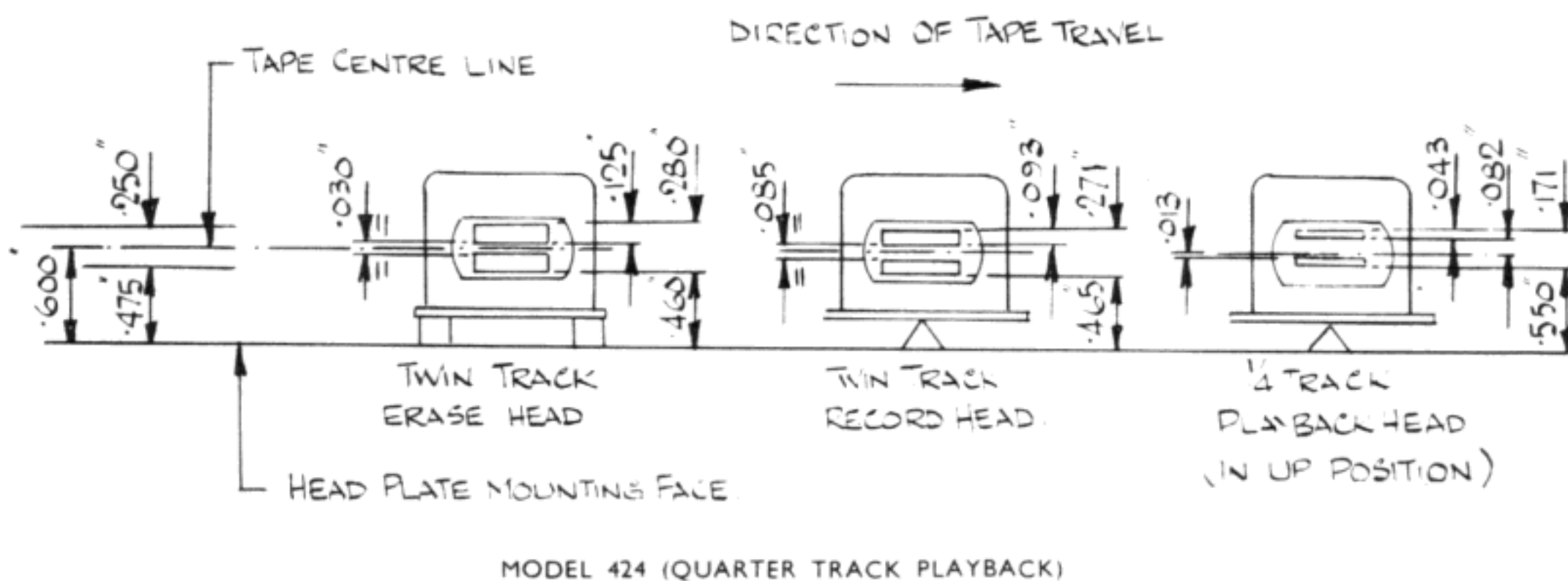
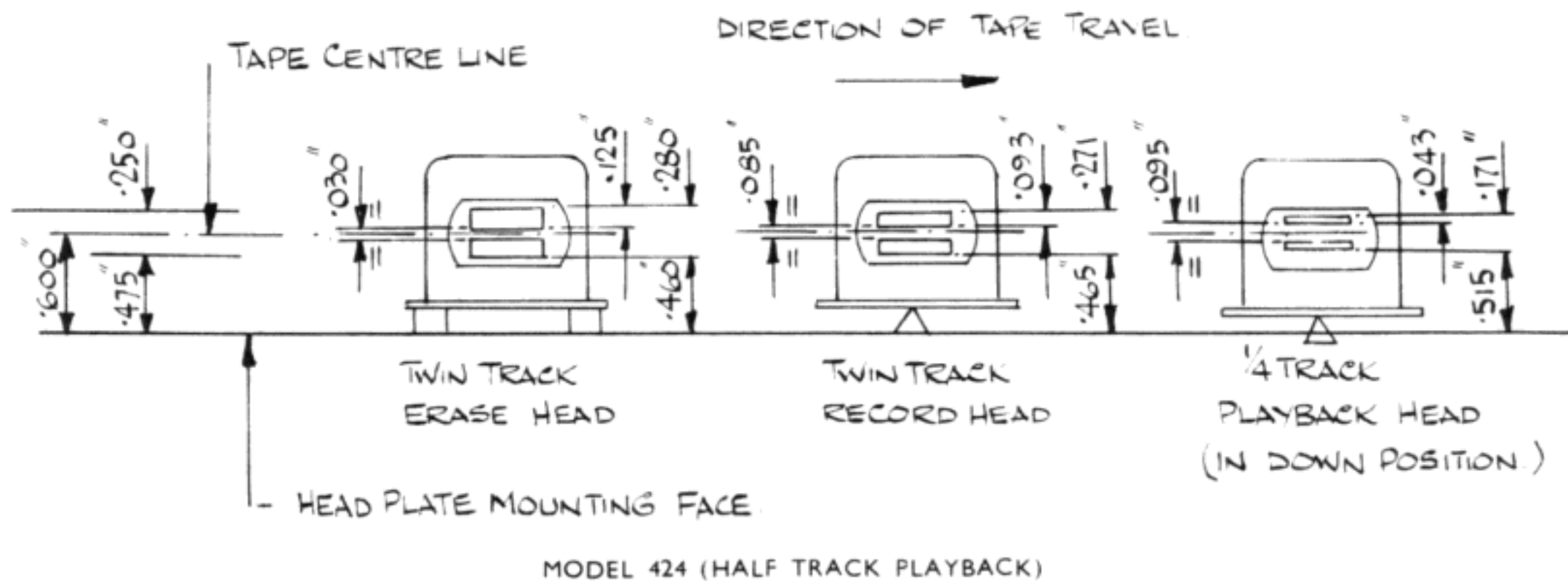
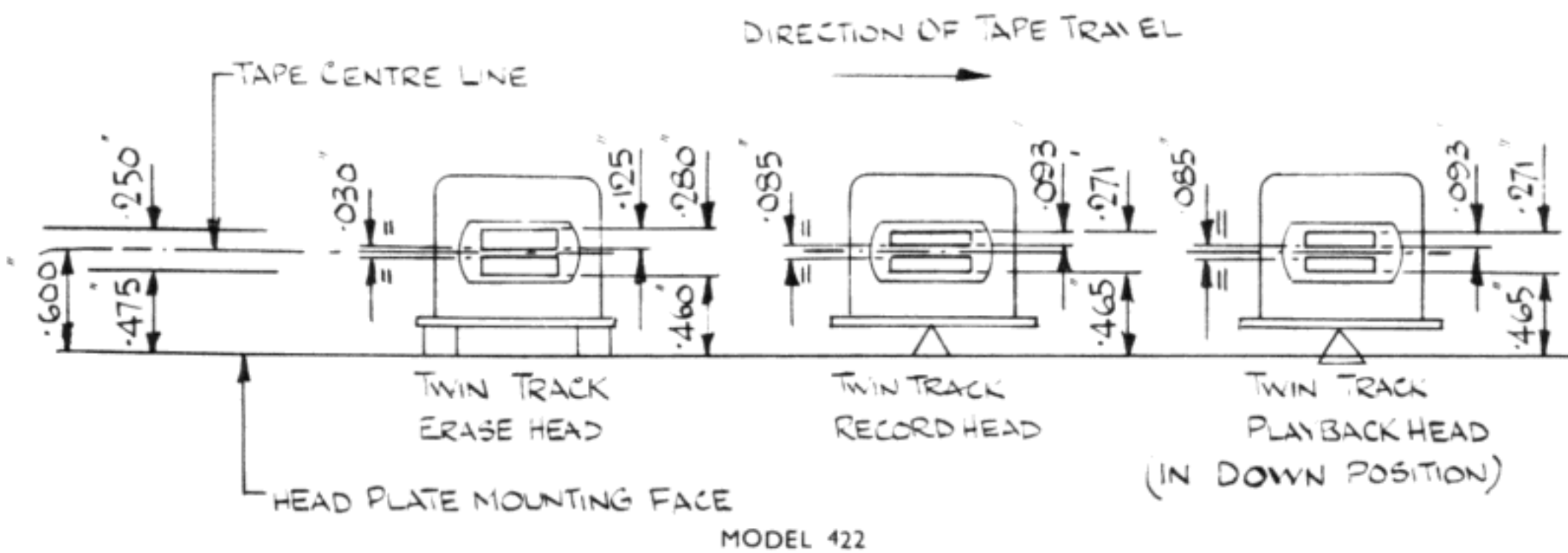

FIG. 14

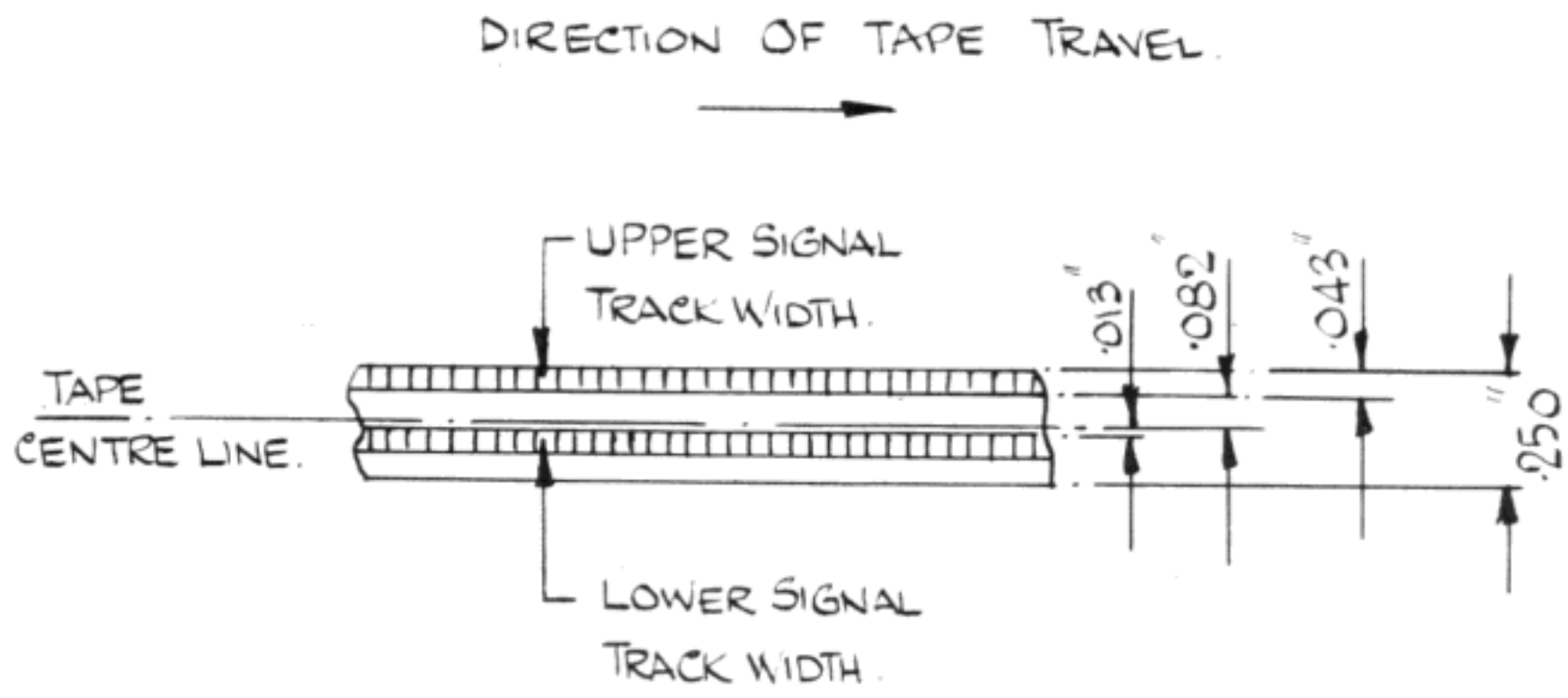
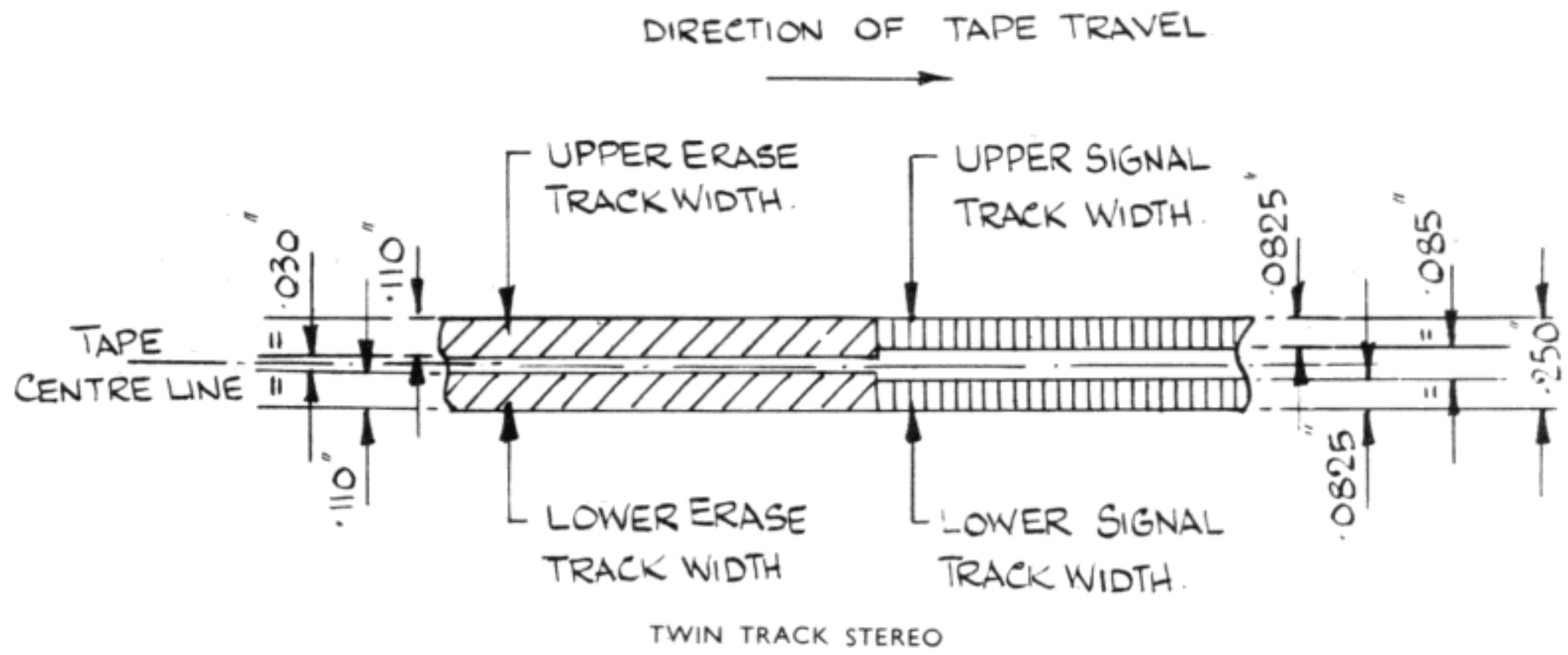
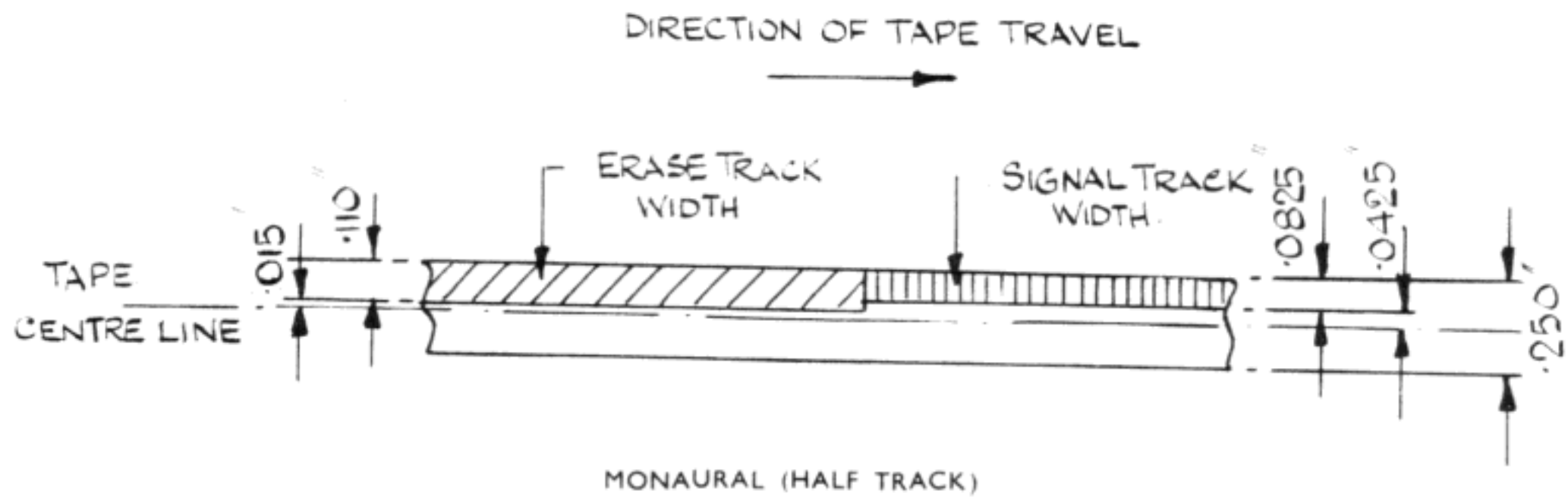

FIG. 15.

APPENDIX B

COMPONENTS LIST FOR MODEL 422U AND 424U FERROGRAPHS

CIRCUIT REF.	VALUE	RATING	TOL.	DESCRIPTION	PART NOS.
R1	150K Ω	$\frac{1}{2}$ w	20% _o	Carbon	BP/2927/R
R2	1.2K Ω	27w		Vitreous Enamel	BP/2819/R
R3	1M Ω	$\frac{1}{2}$ w	20% _o	Carbon	BP/2863/R
R4	1K Ω	$\frac{1}{2}$ w	5% _o	High Stability	BP/2964/R
R5	330K Ω	$\frac{1}{2}$ w	5% _o	High Stability	BP/2963/R
R6	10M Ω	$\frac{1}{2}$ w	20% _o	Carbon	BP/2866/R
R7	220K Ω	$\frac{1}{2}$ w	5% _o	High Stability	BP/2903/R
R8	330K Ω	$\frac{1}{2}$ w	10% _o	Carbon	BP/2869/R
R9	220K Ω	$\frac{1}{2}$ w	5% _o	Carbon	BP/2919/R
R10	250K Ω			Dual Carbon Pot. (with R37)	BP/2436/P
R11	330K Ω	$\frac{1}{2}$ w	10% _o	Carbon	BP/2869/R
R12	8.2K Ω	$\frac{1}{2}$ w	5% _o	Carbon	BP/2838/R
R13	500K Ω			Dual Carbon Pot. (with R39)	BP/2438/P
R14	220K Ω	$\frac{1}{2}$ w	5% _o	Carbon	BP/2919/R
R15	100K Ω	$\frac{1}{2}$ w	20% _o	Carbon	BP/2852/R
R16	47K Ω	$\frac{1}{2}$ w	20% _o	Carbon	BP/2849/R
R17	*150K Ω			Selected at Works	
R18	1.8K Ω	$\frac{1}{2}$ w	5% _o	Carbon	BP/2937/R
R19	1M Ω	$\frac{1}{2}$ w	20% _o	Carbon	BP/2863/R
R20	8.2K Ω	$\frac{1}{2}$ w	5% _o	Carbon	BP/2838/R
R21	1K Ω	$\frac{1}{2}$ w	5% _o	Carbon	BP/2908/R
R22	22K Ω	1w	10% _o	Carbon	BP/2918/R
R23	4.7K Ω	$\frac{1}{2}$ w	10% _o	Carbon	BP/2831/R
R24	100K Ω	1w	20% _o	Carbon	BP/2886/R
R25	1M Ω	$\frac{1}{2}$ w	5% _o	Carbon	BP/2888/R
R26	*1M Ω			Selected at Works	
R27	47K Ω	$\frac{1}{2}$ w	20% _o	Carbon	BP/2849/R
R28	10M Ω	$\frac{1}{2}$ w	20% _o	Carbon	BP/2866/R
R29	1K Ω			Carbon Pot.	BP/2437/P
R30	1M Ω	$\frac{1}{2}$ w	20% _o	Carbon	BP/2863/R
R31	1K Ω	$\frac{1}{2}$ w	5% _o	High Stability	BP/2964/R
R32	330K Ω	$\frac{1}{2}$ w	5% _o	High Stability	BP/2963/R
R33	10M Ω	$\frac{1}{2}$ w	20% _o	Carbon	BP/2866/R
R34	220K Ω	$\frac{1}{2}$ w	5% _o	High Stability	BP/2903/R
R35	330K Ω	$\frac{1}{2}$ w	10% _o	Carbon	BP/2869/R
R36	220K Ω	$\frac{1}{2}$ w	5% _o	Carbon	BP/2919/R

Appendix B—continued

CIRCUIT REF.	VALUE	RATING	TOL.	DESCRIPTION	PART NOS.
R37	250K Ω			Dual Carbon Pot. (with R10)	BP /2436 /P
R38	330K Ω	$\frac{1}{2}$ W	10% _o	Carbon	BP /2869 /R
R39	500K Ω			Dual Carbon Pot. (with R13)	BP /2438 /P
R40	220K Ω	$\frac{1}{2}$ W	5% _o	Carbon	BP /2919 /R
R41	100K Ω	$\frac{1}{2}$ W	20% _o	Carbon	BP /2852 /R
R42	47K Ω	$\frac{1}{2}$ W	20% _o	Carbon	BP /2849 /R
R43	*150K Ω			Selected at Works	
R44	1-8K Ω	$\frac{1}{2}$ W	5% _o	Carbon	BP /2937 /R
R45	1M Ω	$\frac{1}{2}$ W	20% _o	Carbon	BP /2863 /R
R46	8-2K Ω	$\frac{1}{2}$ W	5% _o	Carbon	BP /2838 /R
R47	1K Ω	$\frac{1}{2}$ W	5% _o	Carbon	BP /2908 /R
R48	22K Ω	1W	10% _o	Carbon	BP /2918 /R
R49	1K Ω	$\frac{1}{2}$ W	5% _o	High Stability	BP /2964 /R
R50	330K Ω	$\frac{1}{2}$ W	5% _o	High Stability	BP /2963 /R
R51	220K Ω	$\frac{1}{2}$ W	5% _o	High Stability	BP /2903 /R
R52	250K Ω			Pre-Set Carbon Pot.	BP /2435 /P
R53	10M Ω	$\frac{1}{2}$ W	20% _o	Carbon	BP /2866 /R
R54	250K Ω			Pre-Set Carbon Pot.	BP /2435 /P
R55	220K Ω	$\frac{1}{2}$ W	5% _o	Carbon	BP /2919 /R
R56	500K Ω			Dual Carbon Pot. (with R68)	BP /2438 /P
R57	250K Ω			Pre-Set Carbon Pot.	BP /2435 /P
R58	33K Ω	$\frac{1}{2}$ W	20% _o	Carbon	BP /2845 /R
R59	4-7K Ω	$\frac{1}{2}$ W	10% _o	Carbon	BP /2831 /R
R60	4-7K Ω	$\frac{1}{2}$ W	10% _o	Carbon	BP /2831 /R
R61	1K Ω	$\frac{1}{2}$ W	5% _o	High Stability	BP /2964 /R
R62	330K Ω	$\frac{1}{2}$ W	5% _o	High Stability	BP /2963 /R
R63	220K Ω	$\frac{1}{2}$ W	5% _o	High Stability	BP /2903 /R
R64	250K Ω			Pre-Set Carbon Pot. Lin.	BP /2435 /P
R65	10M Ω	$\frac{1}{2}$ W	20% _o	Carbon	BP /2866 /R
R66	250K Ω			Pre-Set Carbon Pot. Lin.	BP /2435 /P
R67	220K Ω	$\frac{1}{2}$ W	5% _o	Carbon	BP /2919 /R
R68	500K Ω			Dual Carbon Pot. (with R56)	BP /2438 /P
R69	250K Ω			Pre-Set Carbon Pot. Lin.	BP /2435 /P
R70	33K Ω	$\frac{1}{2}$ W	20% _o	Carbon	BP /2845 /R

Appendix B—continued

CIRCUIT REF.	VALUE	RATING	TOL.	DESCRIPTION	PART NOS.
R71	4-7K Ω	$\frac{1}{2}$ w	10% _o	Carbon	BP 2831 R
R72	4-7K Ω	$\frac{1}{2}$ w	10% _o	Carbon	BP 2831 R
R73	4-7K Ω	$\frac{1}{2}$ w	10% _o	Carbon	BP 2831 R
R74	250K Ω			Pre-Set Carbon Pot. Lin.	BP 2435 P
R75	620 Ω	$\frac{1}{2}$ w	5% _o	Carbon	BP 2881 R
R76	10K Ω	$\frac{1}{2}$ w	5% _o	Carbon	BP 2926 R
R77	100 Ω	1w	5% _o	Carbon	BP 2968 R
R78	10K Ω	$\frac{1}{2}$ w	5% _o	Carbon	BP 2926 R
R79	5-6K Ω	1w	5% _o	Carbon	BP 2947 R
R80	25K Ω			Pre-Set Carbon Pot.	BP 2402 P
R81	10M Ω	$\frac{1}{2}$ w	20% _o	Carbon	BP 2866 R
R82	5 Ω	6w		Vitreous Enamel	BP 2799 R
R83	2-2K Ω	1w	10% _o	Carbon	BP 2966 R
R84	47 Ω	1w	5% _o	Carbon	BP 2990 R
R85	10M Ω	$\frac{1}{2}$ w	20% _o	Carbon	BP 2866 R
R86	5K Ω			Pre-Set Pot.	BP 2428 P
R87	25K Ω			Pre-Set Carbon Pot.	BP 2402 P
R88	15K Ω	$\frac{1}{2}$ w	20% _o	Carbon	BP 2842 R
R89	470 Ω	$\frac{1}{2}$ w	10% _o	Carbon	BP 2815 R
R90	56 Ω	2w		Vitreous Enamel	BP 2797 R
R91	100K Ω	$\frac{1}{2}$ w	20% _o	Carbon	BP 2852 R
R92	*47K Ω			Selected at Works	
R93	*47K Ω			Selected at Works	
R94	100K Ω	$\frac{1}{2}$ w	20% _o	Carbon	BP 2852 R
R95	100K Ω	$\frac{1}{2}$ w	20% _o	Carbon	BP 2852 R
C1	.75 μ F	450v		Paper	BP 715 C
C2	.1 μ F	300v AC		Paper	BP 707 C
C3	2200pf	500v	20% _o	Ceramic	BP 527 C
C4	2200pf	500v	20% _o	Ceramic	BP 527 C
C5	16 μ F	350v		Electrolytic (with C8 and C36)	BP 773 C
C6	4700pf	500v	100-0% _o	Ceramic	BP 530 C
C7	.047 μ F	400v	10% _o	Polyester	BP 706 C
C8	8 μ F	350v		Electrolytic (with C5 and C36)	BP 773 C
C9	.02 μ F	400v	10% _o	Polyester	BP 704 C
C10	.01 μ F	500v	100-0% _o	Silver Ceramic	BP 558 C
C11	4700pf	500v	100-0% _o	Ceramic	BP 530 C

Appendix B—continued

CIRCUIT REF.	VALUE	RATING	TOL.	DESCRIPTION	PART NOS.
C12	50 μ F	12v		Electrolytic	BP /763 /C
C13	0.47 μ F	400v	10% _o	Polyester	BP /706 /C
C14	5 μ F	500v	10% _o	Paper	BP /714 /C
C15	*4000pf			Selected at Works	
C16	*2000pf			Selected at Works	
C17	8 μ F	350v		Electrolytic (with C29 and C52)	BP /773 /C
C18	22 μ F	125v	10% _o	Polyester	BP /710 /C
C19	4700pf	500v	+100-0% _o	Ceramic	BP /530 /C
C20	0.47 μ F	400v	10% _o	Polyester	BP /706 /C
C21	0.2 μ F	400v	10% _o	Polyester	BP /704 /C
C22	0.1 μ F	500v	+100-0% _o	Silver Ceramic	BP /558 /C
C23	4700pf	500v	+100-0% _o	Ceramic	BP /530 /C
C24	4700pf	500v	+100-0% _o	Ceramic	BP /530 /C
C25	0.47 μ F	400v	10% _o	Polyester	BP /706 /C
C26	0.47 μ F	400v	10% _o	Polyester	BP /714 /C
C27	*4000pf			Selected at Works	
C28	*2000pf			Selected at Works	
C29	16 μ F	350v		Electrolytic (with C17 and C52)	BP /773 /C
C30	*4700pf			Selected at Works	
C31	*4700pf			Selected at Works	
C32	4700pf	500v	+100-0% _o	Ceramic	BP /530 /C
C33	*1500pf			Selected at Works	
C34	0.2 μ F	400v	10% _o	Polyester	BP /704 /C
C35	0.47 μ F	125v	10% _o	Polyester	BP /712 /C
C36	16 μ F	350v		Electrolytic (with C5 and C8)	BP /773 /C
C37	*4700pf			Selected at Works	
C38	*4700pf			Selected at Works	
C39	4700pf	500v	+100-0% _o	Ceramic	BP /530 /C
C40	*1500pf			Selected at Works	
C41	0.2 μ F	400v	10% _o	Polyester	BP /704 /C
C42	0.47 μ F	125v	10% _o	Polyester	BP /712 /C
C43	8 μ F	500v		Electrolytic	BP /751 /C
C44	22 μ F	125v	10% _o	Polyester	BP /710 /C
C45	22 μ F	125v	10% _o	Polyester	BP /710 /C
C46	5700pf	350v	10% _o	Polystyrene	BP /521 /C

Appendix B—continued

CIRCUIT REF.	VALUE	RATING	TOL.	DESCRIPTION	PART NOS.
C47	8 μ F	500v		Electrolytic	BP /752 /C
C48	100 μ F	25v		Electrolytic	BP /781 /C
C49	50 μ F	500v		Electrolytic	
C50	2000 μ F	25v		(with C51) Electrolytic	BP /772 /C
C51	50 μ F	500v		Electrolytic	BP /771 /C
C52	16 μ F	350v		(with C49) Electrolytic	BP /772 /C
C53	2000pf	350v	2%	(with C17 and C29) Electrolytic	BP /773 /C
C54	2000pf	350v	2%	Polystyrene	BP /517 /C
C55	47pf	350v	10%	Polystyrene	BP /517 /C
C56	-047 μ F	400v	10%	Polystyrene	BP /505 /C
				Polyester	BP /706 /C
CIRCUIT REF.	DESCRIPTION			PART NOS.	
V1	Valve Type ECC83			BP /7130 /V	
V2	Valve Type ECC83			BP /7130 /V	
V3	Valve Type ECC82			BP /7118 /V	
V4	Valve Type ECC83			BP /7130 /V	
V5	Valve Type ECC83			BP /7130 /V	
V6	Valve Type ECC83			BP /7130 /V	
V7	Valve Type ECC82			BP /7118 /V	
V8	Valve Type ECC83			BP /7130 /V	
V9	Valve Type ECC82			BP /7118 /V	
SW1	Selector Switch			MC /3723	
SW2	Auto Stop Switch			MC /3835	
SW3	Manual Stop Switch			MC /1216C	
SW4	Manual Start Switch			MC /1216B	
SW5	Speed Change Switch			MC /2228	
SW6	Equaliser Switch			BP /4080 /S	
SW7	Slide Switch			BP /4071 /S	
SW8	Toggle Switch			BP /4074 /S	
SW9	Mono-Stereo Switch			BP /4078 /S	
SW10	Slide Switch			BP /4071 /S	

Appedix B—continued

CIRCUIT REF.	DESCRIPTION	PART NOS.
JK1	Jack Socket	BP /1508 /J
JK2	Jack Socket	BP /1508 /J
JK3	Jack Socket	BP /1508 /J
JK4	Jack Socket	BP /1508 /J
JK5	Jack Socket	BP /1508 /J
JK6	Jack Socket	BP /1508 /J
X1	Wind on Motor 200-250v	MC /5230 /150v
X2	Capstan Motor Mains	MC /5599 /240v
X3	Wind Back Motor Models	MC /5229 /150v
X4	Twin Track Erase Head	MC /5537
X5	Twin Track Rec. Head (FR16)	MC /5529 R
X6	Twin Track Playback Head (Model 422) (FP16)	MC /5529 P
X7	Quartertrack Playback Head (Model 424)	MC /5498
P1	Plug Octal	BP /2311 /P
P2	Plug 2 Way	BP /2301 /P
P3	Plug 2 Way	BP /2301 P
P4	Plug 2 Way	BP /2301 /P
P5	Plug 2 Way	BP /2301 /P
P6	Plug 2 Way	BP /2301 /P
P7	Plug 2 Way	BP /2301 /P
P8	Plug Octal	BP /2310 /P
P9	Plug Mains	BP /2307 /P
P10	Plug Octal	BP /2311 /P
SK1	Socket Octal	BP /7050 /V
SK2	Socket 2 Way	BP /3904 /S
SK3	Socket 2 Way	BP /3904 /S
SK4	Socket 2 Way	BP /3904 /S
SK5	Socket 2 Way	BP /3904 /S
SK6	Socket 2 Way	BP /3904 /S
SK7	Socket 2 Way	BP /3904 /S
SK8	Socket Octal	BP /3906 /S
SK9	Socket Mains	BP /3905 /S
SK10	Socket Octal	BP /7050 /V
TR1	Input Transformer	MC /973
TR2	Input Transformer	MC /973
TR3	200-250v Mains Transformer	MC /T1670
TR4	110v Mains Transformer	MC /T1673

Appendix B—continued

CIRCUIT REF.	DESCRIPTION	PART NOS.
L1	Solenoid	MC/T1672
L2	Treble Boost Inductor	MC/727
L3	Treble Boost Inductor	MC/727
L4	Oscillator Coil	MC/5586
FS1	Fuse 1a (Used on 200-250v Mains Models)	BP/1252/F
FS2	Fuse 2a (Used on 117v Mains Models)	BP/1253/F
M1	Meter Reverse Reading	BP/1933/M
MR1	Rectifier	BP/2608/R
MR2	Rectifier	BP/2605/R
MR3	Rectifier	BP/2605/R
MR4	Rectifier	BP/2607/R
MR5	Rectifier	BP/2607/R
MR6	Rectifier	BP/2607/R
MR7	Rectifier	BP/2607/R
LP1	Lamp L.E.S. 6-5v 150mA	BP/1813/L
LP2	Lamp L.E.S. 6-5v 150mA	BP/1813/L

LIST OF COMPONENTS FOR 110v 60c.p.s. VERSIONS, 422A & 424A

The Component Values for these Models are exactly as for Models 422U & 424U with the exceptions listed below :—

CIRCUIT REF.	VALUE	RATING	DESCRIPTION	PART NOS.
R2	250Ω	27W	Vitreous Enamel	BP/2808/R
C1	2.5mfd		Paper	BP/717/C
TR4			Mains Transformer	MC/T1673
X1			Wind On Motor	MC/5230/75v
X2			Capstan Motor	MC/5599/110v
X3			Wind Back Motor	MC/5229/75v

The 110v 50c.p.s. versions 422E & 424E differ from the above in two particulars only :—

C1 3.0mfd 300v A.C. Paper BP/718/C
 Motor Pulley MC/3913 is used instead of MC/3914.

**Note—Values are Nominal Values only. Actual Values are selected in test.*

The following accessories are available for use with the Ferrograph.

Carrying Case for Series 420

Best quality waterproof canvas with zip fastener. Gives full protection against rain and dust.

Defluxer

For demagnetising the record / playback head. Prevents hiss and protects tapes from cumulative background noise.

Endless Loop Cassette

As described in the manual.

Erase Link Potentiometer

As described in Manual, Section 7. BP /2434 /P.

Low Impedance Microphones

Type RBL /TM, high fidelity, low impedance (30 ohms) fitted with 3 pin plug /socket mount for attaching to a floor, table or desk stand with 18 feet screened lead and plug, and incorporating matching unit in lead.

Type RBL /T, high fidelity, low impedance (30 ohms) microphone with 3 pin /socket mount and fitted with 18 ft. screened lead and plug.

Microphone Matching Unit

Type TA /30GL, incorporating transformer for use with 30 ohm Microphone type RBL /T above.

Microphone Stands

Heavy bases finished grey with chromium pillars. Desk model height 8 inches. Table model, adjustable, 16 /24 inches. Floor model, adjustable, 3 ft. / 5 ft. 9 ins.

Tape

Hublok reels (full standard tape)	200 ft. Ferrograph FT3A
	600 ft. Ferrograph FT5A
	1200 ft. Ferrograph FT7A
	1750 ft. Ferrograph FT8A

Empty Reels

Hublok reels (empty)	200 ft. Ferrograph RE3
	600 ft. Ferrograph RE5
	1200 ft. Ferrograph RE7
	1750 ft. Ferrograph RE8

Miscellaneous

The following spares can also be supplied:

Meter illuminating lamp	LES 6.5V 150mA BP /1813 /L
Fuse	1A BP /1252 /F
Fuse	2A BP /1253 /F
Unscreened jack plug	UP7
Screened jack plug	SP7
Octal plug	Bulgin Q575 BP /2303 /P

Tape deck parts which may require replacement after long use or accidental damage are indicated in the illustrations. When ordering these, please specify the part number and the serial number of the Ferrograph (rear of cabinet).

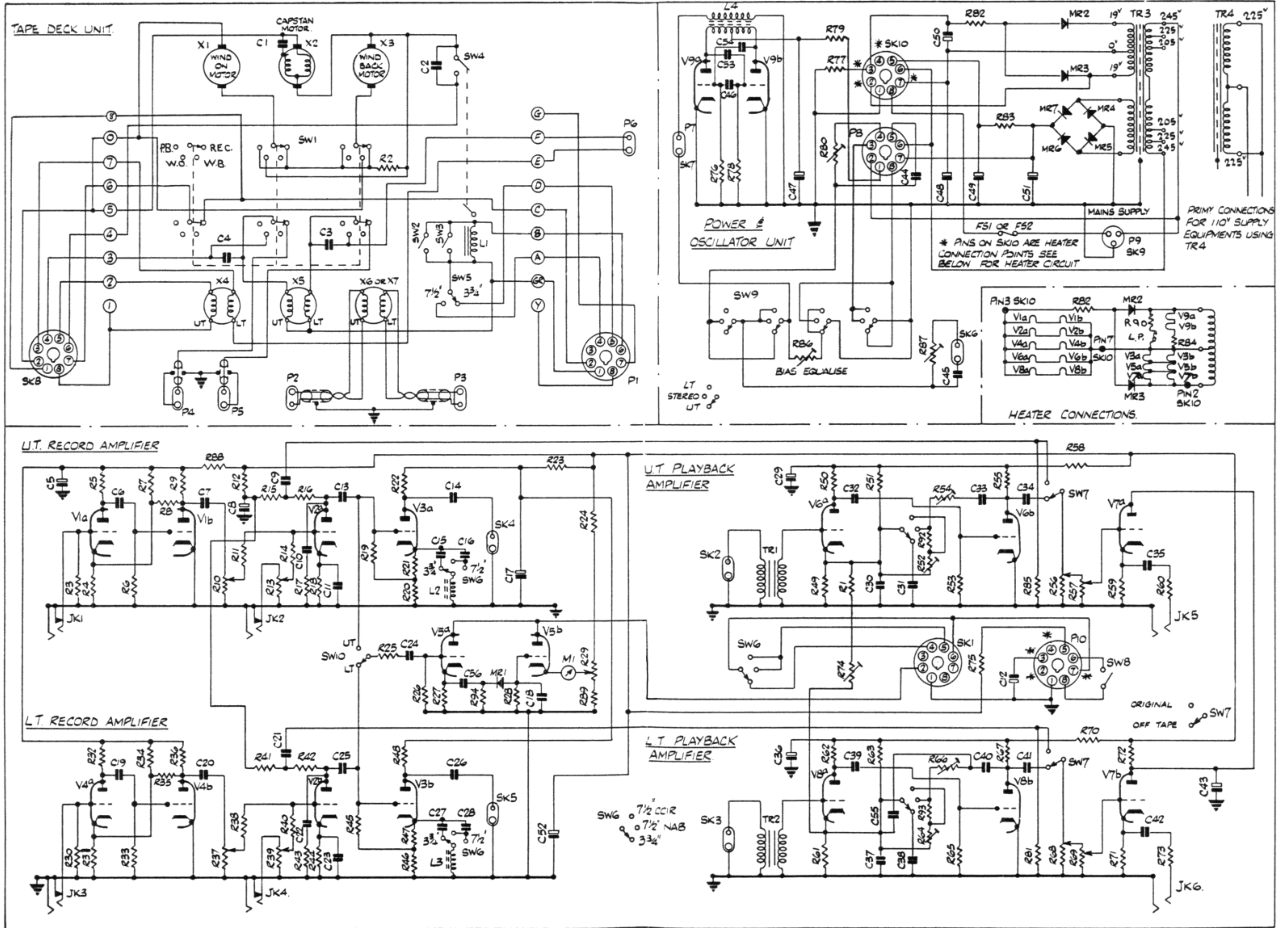

FIG. 16. COMPLETE CIRCUIT DIAGRAM, SERIES 420