

THE MANUAL  
OF THE  
“FERROGRAPH”

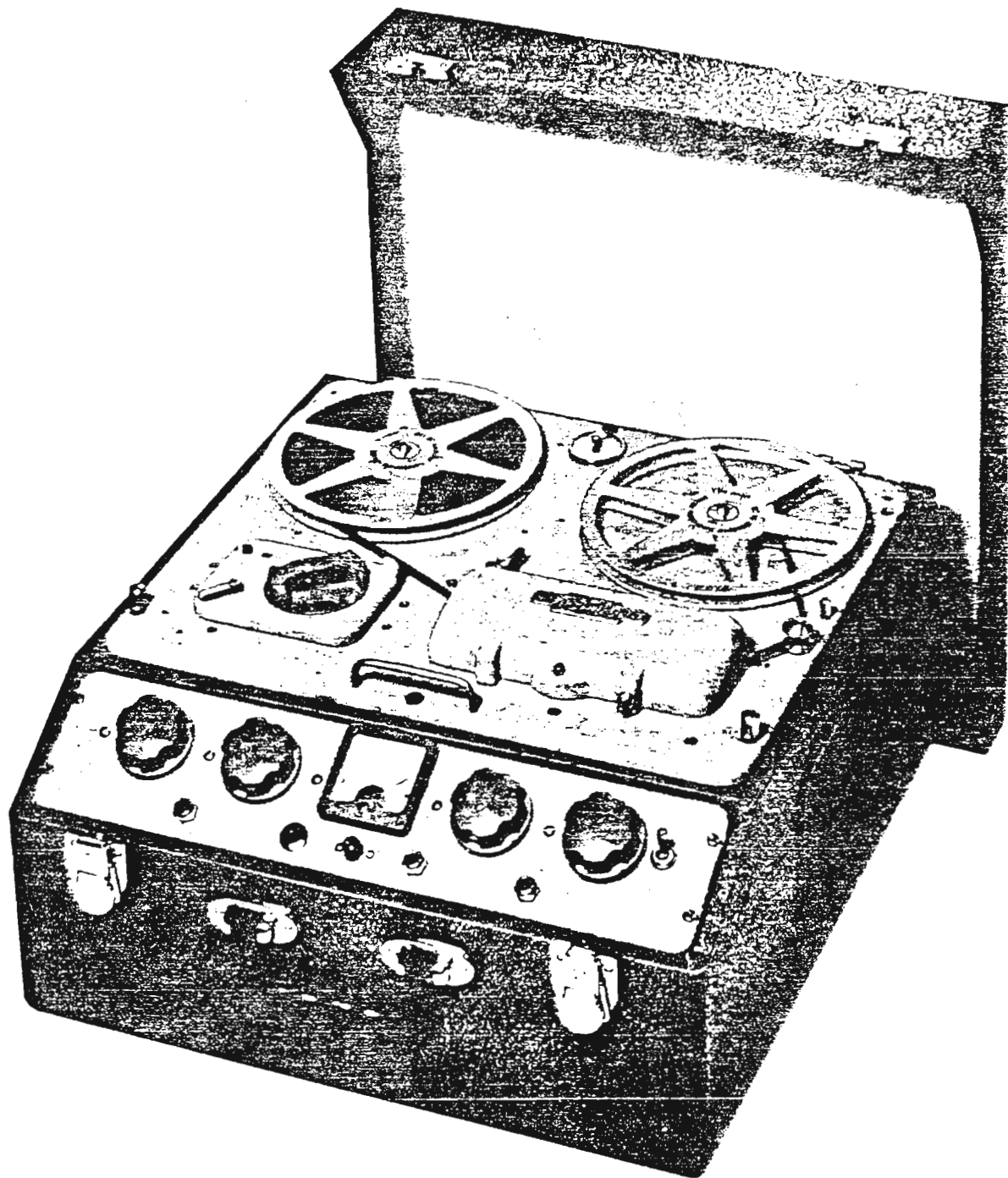

THE FERROGRAPH SERIES 4

## ERRATA AND ADDENDA

### Fig. 18—Page 33

Tape guide MP/1827 should read MP/3281.

Felt pad BP/1102/F is now BP/1109/F.

Capstan flywheel assembly MP/1833 should read MP/2196.

### Section 21 and Ferrograph Model 4S—Pages 42, 45, 46

The FP.14 head has been superseded by the latest stereo head type FP.16 which will fit in the same way as the FP.14 head except that its height should be adjusted so that the head laminations overlap equally the top and bottom edges of the tape running through on playback.

The playback transformer 979 is superseded by the type 973A which is of identical construction but has a step-up ratio of 15 : 1 and a better high frequency response.

When feeding into amplifiers of 100k ohm impedance and lower, the 969 head matching transformer is available with a step-up ratio of 8 : 1.

### Replacement Components

At the beginning of 1960 the value of the 3k ohms potentiometers (R4, R25, R38 and R44) was changed to 5k ohm. R4, R38, and R44 became BP/2428/P and this component is a replacement for all earlier models. The meter zero (R25) became a carbon potentiometer BP/2433/P and again this is a replacement for earlier models.

In 1961, SW6 (Mains ON/OFF) became BP/4074/S (square body) and is also a replacement for all models.

Later equipments have the automatic stop switch MC/1216A replaced by switch block MC/3345 with contact clip MC/3303 on the insulated pressure arm pin.

### Serial Nos. 4/6100 onwards

These instruments have output transformer T1663 fitted instead of T1428. They are electrically identical but use different methods of mounting and, therefore, are not interchangeable.

### Serial Nos. 4/14,000 onwards

On these recorders the amplifier panel is fitted with metal capped knobs MC/3867 and dummy plug MC/3947, and the meter is mounted behind the panel and becomes BP/1933/M. It is illuminated from the side by 2 sub-miniature lamps (6.5v, 0.15A) BP/1813/L in holders LES 14, BP/1814/H. These are connected in parallel and are across the heater supply in series with a 4.7 ohm resistor BP/2795/R which reduces the lamp voltage to 5V. Neon BP/1810/L and R24 (4.7k ohm) are omitted. The meter zero potentiometer is 2k ohm and replacements are BP/2441/P mounted on panel MP/3890 and fitted with knob MP/3994.

### Appendix D . . . Steread Unit

The Steread Unit has ceased production and is no longer available.

# CONTENTS

	<i>Page</i>
FOREWORD	
GENERAL SPECIFICATION	2
GENERAL INFORMATION	3
1. Operating Instructions	5
2. To Load the Machine	6
3. To Select Speeds	8
4. To Play Back	8
5. Winding Back and Winding On	9
6. To Record	10
6.1 From Radio	10
6.1.1. Extension Speaker Socket System	10
6.1.2. Direct from Detector System	12
6.1.3. Microphone Method	13
6.2. Gramophone Record Transcriptions	13
6.3. Live Recording	13
6.4. Recording from 600 ohm lines	16
6.5. Simultaneous, Live and Relayed Recording	16
7. Brief Stop	17
8. To Play Back After Recording	17
8.1. Use of Tone Controls	17
8.2. To Play Back over other Amplifiers, etc.	19
9. To Erase Unwanted Recording	20
10. The Erase Link	20
11. Auxiliary Sockets	21
12. To Change Tracks	21
13. Editing and Splicing Tape	22
14. Spools	23
15. Endless Loops	24
16. Storage of Recordings	25
17. Care and Maintenance	25
18. Technical Notes on Circuitry	29
18.1. Recording Amplifier	29
18.2. The Oscillator	30
18.3. The Mechanical Unit—Design Details	31
18.4. The Playback Amplifier	34
19. Testing and Alignment	35
19.1. Voltages	35
19.2. Gain	36
19.3. Equalisation	37
19.4. Bias Trap	37
19.5. Head Alignment	38
19.6. Checking the Entire Instrument	38

For Service Manuals Contact  
**MAURITRON TECHNICAL SERVICES**  
 8 Cherry Tree Rd, Chinnor  
 Oxon OX9 4QY  
 Tel: 01844-351694 Fax: 01844-352554  
 Email: enquiries@mauritron.co.uk

19. Testing and Alignment ( <i>continued</i> )								
19.6.1. Recording Level ...	...	...	...	...	...	...	...	38
19.6.2. Bias Checking ...	...	...	...	...	...	...	...	39
19.6.3. "Wow" and "Flutter" ...	...	...	...	...	...	...	...	40
19.6.4. Frequency Response ...	...	...	...	...	...	...	...	40
19.6.5. Hum Level ...	...	...	...	...	...	...	...	41
19.6.6. Signal to Noise Ratio ...	...	...	...	...	...	...	...	42
20. Alternative Models ...	...	...	...	...	...	...	...	42
21. Conversion of 4A to 4S ...	...	...	...	...	...	...	...	42
MODEL 4A/CON								
Appendix A. Operational Fault Analysis ...	...	...	...	...	...	...	...	52
Appendix B. List of Components—Series 4 ...	...	...	...	...	...	...	...	54
Appendix C. NARTB Characteristic ...	...	...	...	...	...	...	...	59
Appendix D. Accessories ...	...	...	...	...	...	...	...	59
Appendix E. Magnetic Sound Recording Tape, Spec WW372/49 ...	...	...	...	...	...	...	...	62

---

### LIST OF DIAGRAMS AND PLATES

<i>Description</i>	<i>Fig.</i>	<i>Page</i>
Supply Panel ...	1	5
Loading the Machine ...	2	6
Controls ...	3	7
Tape Loading ...	4	9
Track Dispositions ...	5	14
Auxiliary Socket 1 Wiring ...	6	14
Auxiliary Socket 2 Wiring ...	7	14
Tape Splicing ...	8	18
Frequency Response Curve 7½" p.s. ...	9	18
Frequency Response Curve 3¾" p.s. ...	10	19
Loop Operation ...	11	22
Loading of Loop Cassette ...	12	23
Power Unit, Top View... ..	13	25
Power Unit, Underside View ...	14	26
Amplifier, Underside View ...	15	27
Amplifier, Top View ...	16	28
View of Underside of Deck ...	17	32
Head and Capstan Assembly ...	18	33
Model 4S. showing Stereo Head in position	19	44
Circuit Diagram (Standard) ...	20	48
Mounting Cut out for Series 4/CON ...	21	50
Plates showing Stereoad Unit	22	61
Wearite Defluxer ...	23	61
Circuit Diagram (Series 4 with NARTB characteristic) ...	24	64

“FERROGRAPH”  
MAGNETIC TAPE RECORDERS  
SERIES 4  
OPERATING INSTRUCTIONS

FOREWORD

The “Ferrograph” is a very versatile instrument—its applications range far and wide over the fields of science, education, entertainment and industry. Moreover, its simplicity of operation together with its high standard of performance commends it equally to the technically unskilled for whom the recording may be an end in itself, as to the engineer or professional recordist for whom it may be a very important link in a complicated system.

This booklet in consequence must have regard to the widely differing outlooks of all these users, if its object — to enable each to derive the maximum possible benefit from the instrument in his chosen field—is to be fulfilled. Much technical information is therefore unavoidable. At the same time explanations in simple terms are necessary for the benefit of those who have no great knowledge of the electronic art.

In all cases, however, the contents of the succeeding pages will repay careful study as they deal not only with the possibilities of the “Ferrograph” but also with its limitations. As in any well ordered scheme of things, a full understanding of the one is equally as important as the other.

THE BRITISH FERROGRAPH RECORDER CO. LTD.  
LONDON AND SOUTH SHIELDS

For Service Manuals Contact  
MAURITRON TECHNICAL SERVICES  
8 Cherry Tree Rd, Chinnor  
Oxon OX9 4QY  
Tel:- 01844-351694 Fax:- 01844-352554  
Email:- enquiries@mauritron.co.uk

# “FERROGRAPH” MODELS 4A & 4AH

## GENERAL SPECIFICATION

Note :—Although figures are quoted for three speeds it should be noted that the series 4 have two speed instruments supplied in two alternative combinations. e.g. 4AH—7½/15 ins/sec or 4A 3¾/7½ ins/sec.

RECORDING MEDIUM	...	Standard or “Extra Play” ¼” plastic coated tape. On reels up to a maximum of 8¼” dia. coating inside.
RACK WIDTH	...	0.1”—displaced to one edge.
NUMBER OF TRACKS	...	2
OPERATING TAPE SPEEDS	...	15, 7½ and 3¾ ins/sec. ± 2%,
PLAYING TIME PER TRACK	...	Large Reel 22½ mins at 15 ins/sec. 1,750 ft Std. Tape 45 mins at 7½ ins/sec. 90 mins at 3¾ ins/sec.
PLAYING TIME PER REEL	...	45 mins, 1½ hours and 3 hours respectively. NOTE :—The above playing times will be increased when “extra play” tape is used.
REWIND TIME (AND WIND ON)	...	Less than one minute for 1,750 ft. reel standard tape.
FREQUENCY RESPONSE	...	3¾” per sec. 50—5,000 c.p.s. ± 3dB (Tape to Spec. WW372/49 with amendments) 7½” per sec. 50—10,000 c.p.s. ± 2dB 15” per sec. 40—15,000 c.p.s. ± 2dB
“WOW” & “FLUTTER”	...	Less than 0.2% at 7.5 and 15 ins/sec. (As a change in tape velocity)
LONG TERM SPEED STABILITY	...	Better than 0.5%, (For constant Mains Input Frequency)
CASE AND BIAS FREQUENCY	...	53 kc/s. approximately.
INPUT LEVELS, (For full Depth Recording)	...	Input 1, minm. signal 0.003v RMS. Input 2, minm. signal 0.1v RMS. Impedances, 1 megohm and 80Kohms respectively.
OUTPUT ARRANGEMENTS	...	15 ohms 10” x 6” internal elliptical speaker. Socket on front panel for external speakers.
OUTPUT POWER	...	2½ watts into 15 ohms.
SIGNAL TO NOISE RATIO	...	In the range 200 cycles to 12 Kc/s., better than 50dB. Unweighted, including hum, 45dB.
WORKING VOLTAGE	...	200—250v. AC.
POWER CONSUMPTION	...	110 watts.
OVERALL DIMENSIONS	...	18½” x 17½” x 9¾” high, with lid.
WEIGHT	...	49¾ lbs.

# THE "FERROGRAPH" MODEL 4A

## GENERAL INFORMATION

The "Ferrograph" stores its sound images in the form of magnetic patterns in the oxide coating of a thin plastic tape. The tape itself is  $\frac{1}{4}$ " wide and only two thousandths of an inch in thickness. 1,250 ft. are accommodated on a reel 7 ins. in diameter.

Because it is a magnetic phenomenon only which is involved and not a physical change in the medium, tape recording has the great advantage over other forms that the medium is not irrevocably consumed each time a recording is made. If a recording is not required for future reference, the tape can be replaced on the "Ferrograph" and used over and over again, the old recording automatically being erased as a new one is made.

Tape is also capable of great fidelity, if properly handled, and if the approach to recorder design has been along strict engineering lines. With the "Ferrograph" the aim has been to make it a strictly linear device, i.e., one which throughout the recording/reproducing process changes the character of the original signal in no way except in intensity.

While it is not possible completely to achieve this aim, of course, it is possible closely to approach it insofar as normally available signals are concerned. Its pursuit though has entailed special treatment in the design of many sections, notably in the recording heads, recording level monitoring and hum suppression.

Briefly the "Ferrograph" consists of the following main components :—

1. An amplifier for magnifying the relatively weak signals from a microphone or the stronger signals from radio apparatus to a predetermined level.
2. A recording head for the conversion of this amplified electrical energy into magnetic energy for impression on to the tape medium.
3. A supersonic oscillator for supplying power to the recording head during the recording operation to assist in the retention of a faithful replica of the original signal and also for feeding an erasing head for obliterating previous recordings.
4. A mechanical drive system for transporting the tape past the heads at given speeds, and for rewinding the tape after recording.
5. A playback or reproducing head for subsequently picking up the magnetic impressions stored on the tape and converting them back into electrical form.
6. An amplifier for amplifying these weak signals, correcting them, and feeding them to the loudspeaker for re-conversion into sound energy.

Economy has suggested, however, and practice has proved, the great advantage of using common circuits and equipment for those operations which are not really required simultaneously, and applying the economic potential thus set free to a general improvement in basic design and facilities. Thus in the "Ferrograph" it has been found expedient to have one amplifier suitably switched, performing the functions of both 1 and 6, and to have a single combined record/reproduce head playing the part of both 2 and 5. Practically speaking, therefore, the instrument resolves itself into three main units :—



- A. The mechanical deck carrying the motors, heads, reels, etc.
- B. The power unit and oscillator.
- C. The amplifier chassis containing the amplifier, monitor meter, etc.

*The Mechanical Unit* is the Wearite "Tape-Deck". It is connected to the amplifier unit by detachable plugs and sockets. Many noteworthy features are incorporated in it, and simplicity of operation is one of its chief characteristics. Among the facilities it provides are :—

- 1. A double track provision which allows double the amount of recorded material to be stored on one reel without any cross talk or sacrifice in performance. This is possible as it operates on only half the tape width at any one time.
- 2. Two running speeds—allowing yet a further doubling of playing time where the frequency range permits.
- 3. Rapid wind-back *and wind-on* of tape.
- 4. An automatic stop switch cutting off the machine unattended at the end of a reel during recording or playing back.
- 5. An instantaneous stop and start of tape transit, preventing slurring.
- 6. A cueing indicator giving an index of tape consumed.
- 7. An ability to accept a continuous loop cassette in place of the standard reels.
- 8. A third head *position*. This is located after the combined record reproduce head. Standard or stereo heads may be plugged in, and there is an adjusting screw for gap alignment.

*The Power Unit and Oscillator* employing two valves is mounted on the floor of the cabinet with its control panel accessible at the rear of the instrument.

*The Amplifier* which employs five valves is mounted together with its operating panel along the front of the instrument.

In the amplifier too are several points worthy of mention at this stage, so that a rapid appreciation of the scope of the instrument will be possible :—

- 1. Two input sockets for accepting the signal to be recorded are provided, each a stage apart in the amplifier, and for low and high level signals respectively.
- 2. Measurement of recording level before application to the tape is carried out by a special peak reading valve-voltmeter which gives sudden transients their true reading, and which allows the maximum possible signal to be impressed upon the tape without fear of overloading or distortion.
- 3. While recording, the quality of the signal cannot be modified by the operator. Providing therefore that the signal itself is good, a full frequency range recording will always be made.
- 4. On playing back however, tone control of both the bass and treble ends of the response is possible, and the frequency spectrum may be varied to suit individual tastes. The level response position is easily set if this facility is not required.
- 5. The general performance of the instrument is such as to warrant playing back over loudspeaker systems capable of rather better acoustical treatment than is possible in the instrument's own case. To this end a 15 ohm outlet has been provided for this and other purposes.

6. Arrangements have been made to break the supersonic bias and erase feed circuits at will, so that interjection by gradual fading in and out is possible.
7. Further to extend the scope of the instrument a socket outlet is provided at the front panel, to which HT, LT and certain other internal connections of the "Ferrograph" are brought. One of the many useful objects of this is to power high quality radio tuner units which may be required to work with it.

Having thus set out very briefly—with the General Specification on Page 2—the broad scope of the machine, consideration may now be given to the operation proper.



## OPERATING INSTRUCTIONS

### 1. BEFORE PUTTING INTO OPERATION

Make sure that the mains input voltage selector knob at the rear of the instrument is in the hole appropriate to the mains voltage in which the machine is to be used. (See Fig. 1). As delivered it will always be in the highest voltage position.

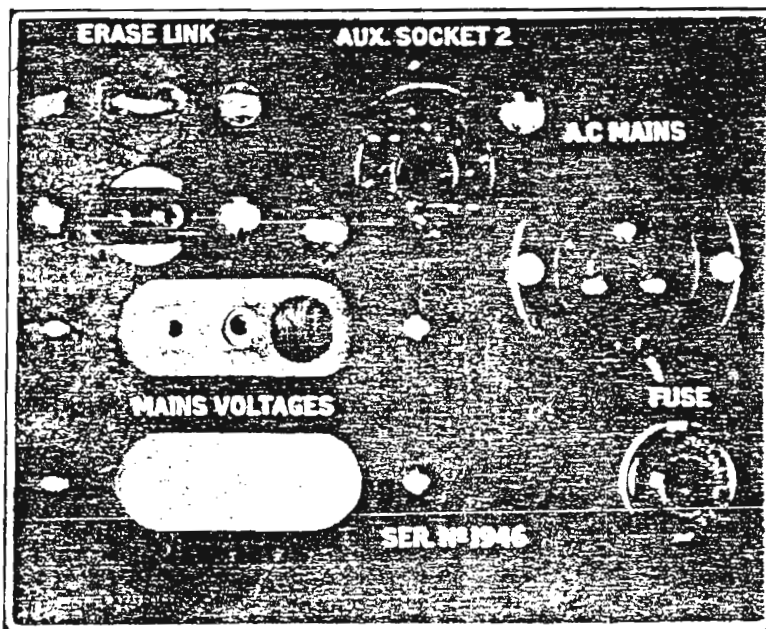

FIG. 1. SUPPLY PANEL

Three tappings are provided to cover the range of 200 to 250 volts, marked as follows:—200 and 210v, 220 and 230v, 240 and 250v.

Having correctly adjusted the mains input and affixed the right type of plug to the end of the lead, the instrument may be switched on by the toggle switch at the extreme right hand of the panel. (See Fig. 3). The neon panel light should glow after approximately 15 secs.

THE MACHINE IS SUITABLE FOR AC MAINS ONLY. DO NOT ATTEMPT TO USE ON DC MAINS.

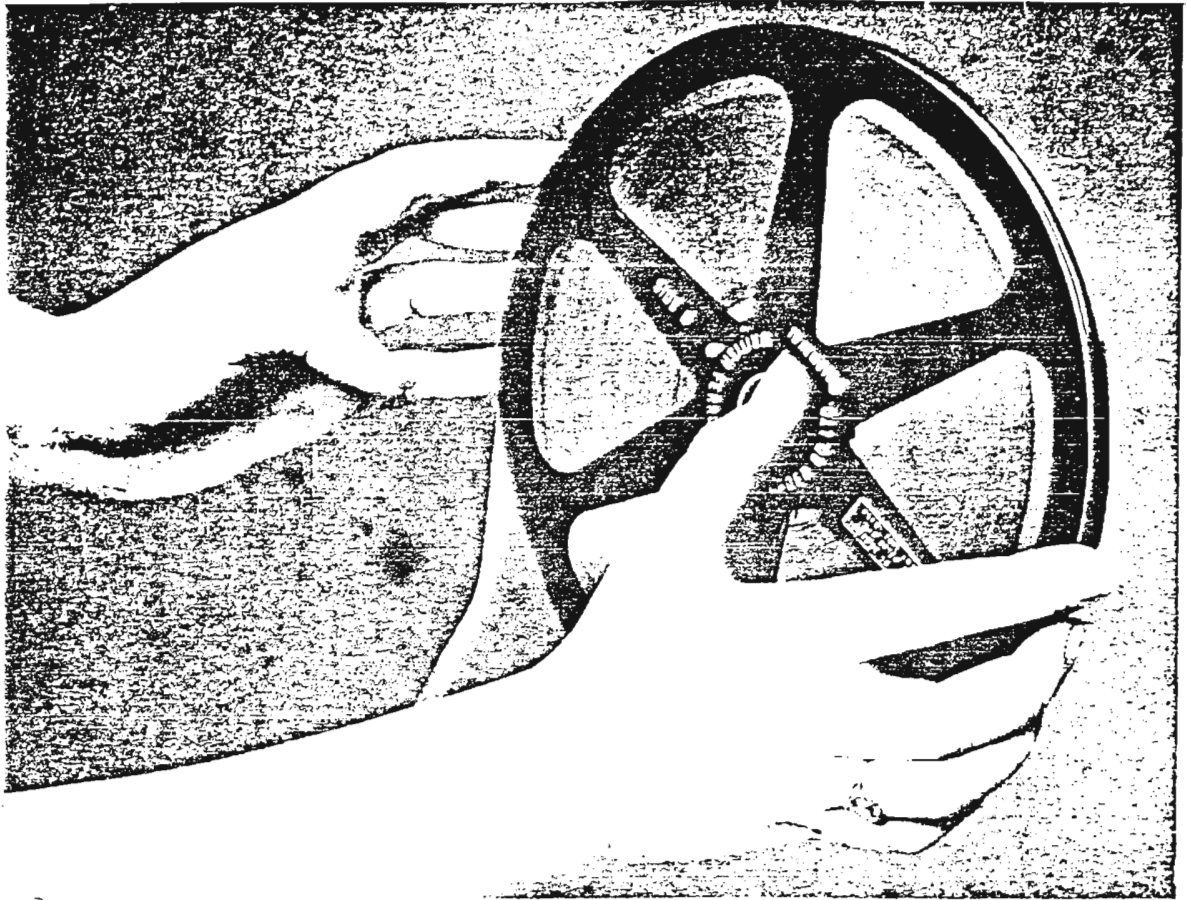

FIG. 2.

## 2. TO LOAD THE MACHINE

First turn the main function switch on the deck itself to either fast wind position indicated by the word fast over an arrow in the knob aperture. This automatically opens the tape gates under the head cover. Load the full reel of tape on the left hand spindle, with the free end at the front and pointing to the right. The coating then should be on the inside.

If "Hublok" reels are being used, observe carefully the method of attaching and detaching them. The small projection should be deflected in the direction of the arrow with the thumb while the reel is being gripped at its rim by the fingers. Do not force the reel on or off without first deflecting the release knob.

Open the head cover, and thread the tape past the heads and over the guides as shown in Fig. 4. The free end should be secured to the empty hub by the built in clip. The red portion is pushed inwards and the tape nipped between the green and cream sections. A few turns of tape can then be wound around the hub in a counter clockwise direction by rotating the reels manually.

The main function switch should now be turned to either record or playback as desired, these operations being indicated by the words 'REC' or 'PLAY' in the knob aperture. Then, after checking that tape is in its correct position and held against the heads by the pressure pads, the head cover can be closed.

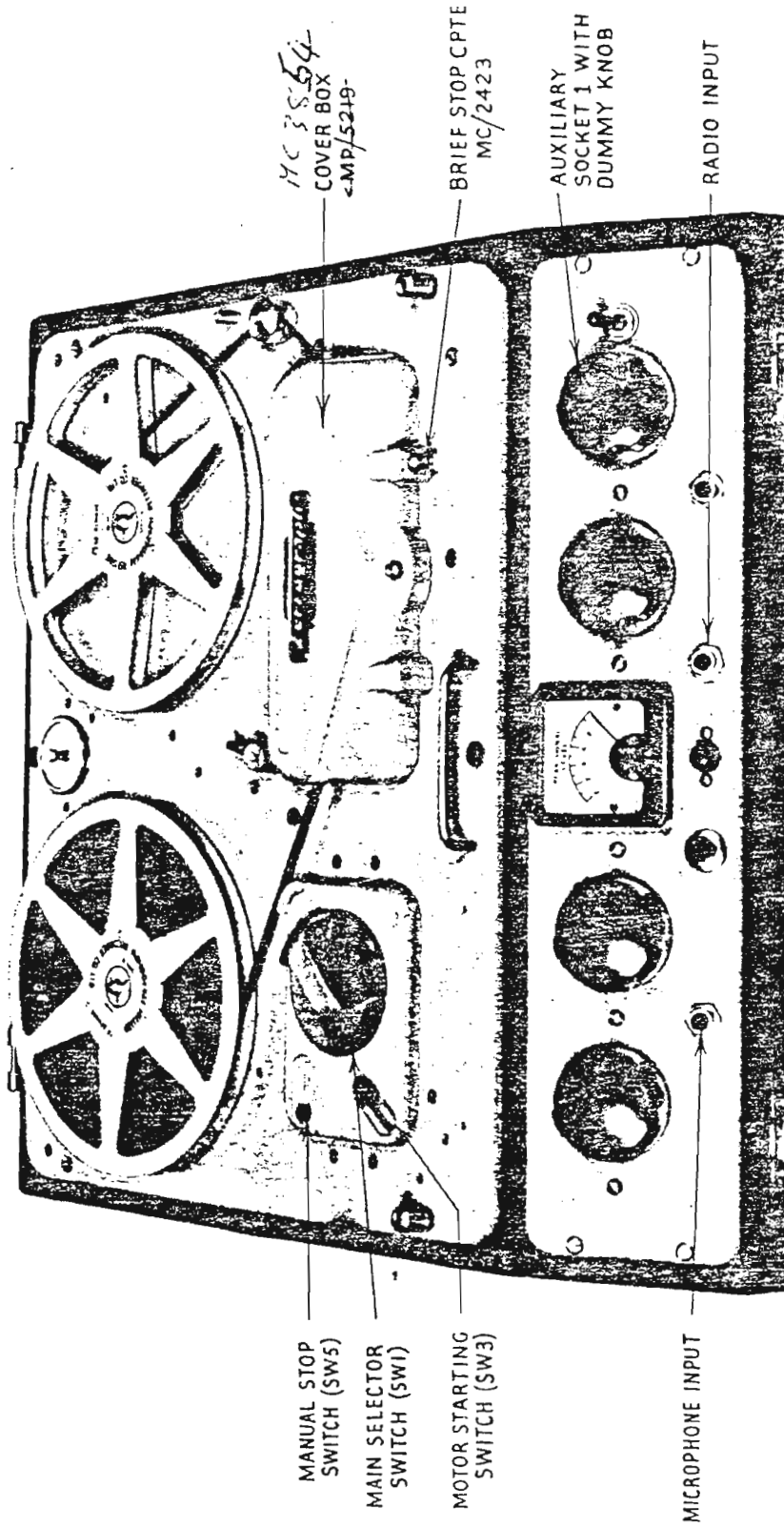

FIG. 3. CONTROLS

The motors may be started, once the machine has been switched on at the panel, by pulling the start button down towards the left hand corner. If the machine is properly warmed up (this usually takes about 20 seconds after switching on) the start button will automatically lock in the "on" position. If it does not lock in and the machine has had ample time to warm up, it is an indication that the tape is not properly positioned in the head guides, and is allowing the automatic stop arm to enter its slot in the erase head.

With the tape running, the adjustment of the "bobbin" guide should be checked, if there is any tendency for the tape to catch on the reel cheeks, the guide may be adjusted for height by first twisting the top and bottom in opposite directions on the support screw to unlock it. The two parts can then be screwed up or down, and locked together finger tight at the required height.

To stop the motors, depress the stop button, keeping the hand clear of the starting knob which will then automatically return.

**DO NOT ATTEMPT TO TURN THE MAIN FUNCTION SWITCH WHILE THE TAPE IS RUNNING.** An automatic locking device has been incorporated to prevent this being done, and any attempt to do so will only impose an undue strain on this mechanism.

### **3. TO SELECT SPEEDS FOR RECORDING OR PLAYBACK**

On the Model "4A" speed selection is extremely easy as it is simply a matter of turning the lever knob in the centre of the "Tape-Deck" to either the right or left, which engages the higher or lower speeds respectively. To avoid undue wear on the idler wheels the mechanism should be stopped while this change is taking place.

The Model "4A" is fitted with a synchronous capstan motor to give a high degree of long-term speed stability and so avoid errors of pitch when recording and playing back. Subject to certain limitations synchronous motors rotate at a speed governed only by the frequency of the mains supply and are normally independent of mains voltage and load variations. To get the motor up to synchronous speed from start however requires more power than is necessary to hold it in synchronism. After the machine has been standing idle for some time, or if it is exceptionally cold, the motor may take a minute or so to come into synchronism. During this time the motor will make a hunting noise, but this will disappear once the correct speed is reached. Thereafter, on switching off and on, the motor should jump straight into synchronism.

### **4. TO PLAY BACK**

Although at first sight consideration of the play-back function before that of recording may seem premature, each instrument leaving the factory will carry some sort of test signal on the start of the reel of tape supplied. This provides an excellent opportunity for becoming acquainted with this phase of the operation and also for checking that the machine is in proper working order.

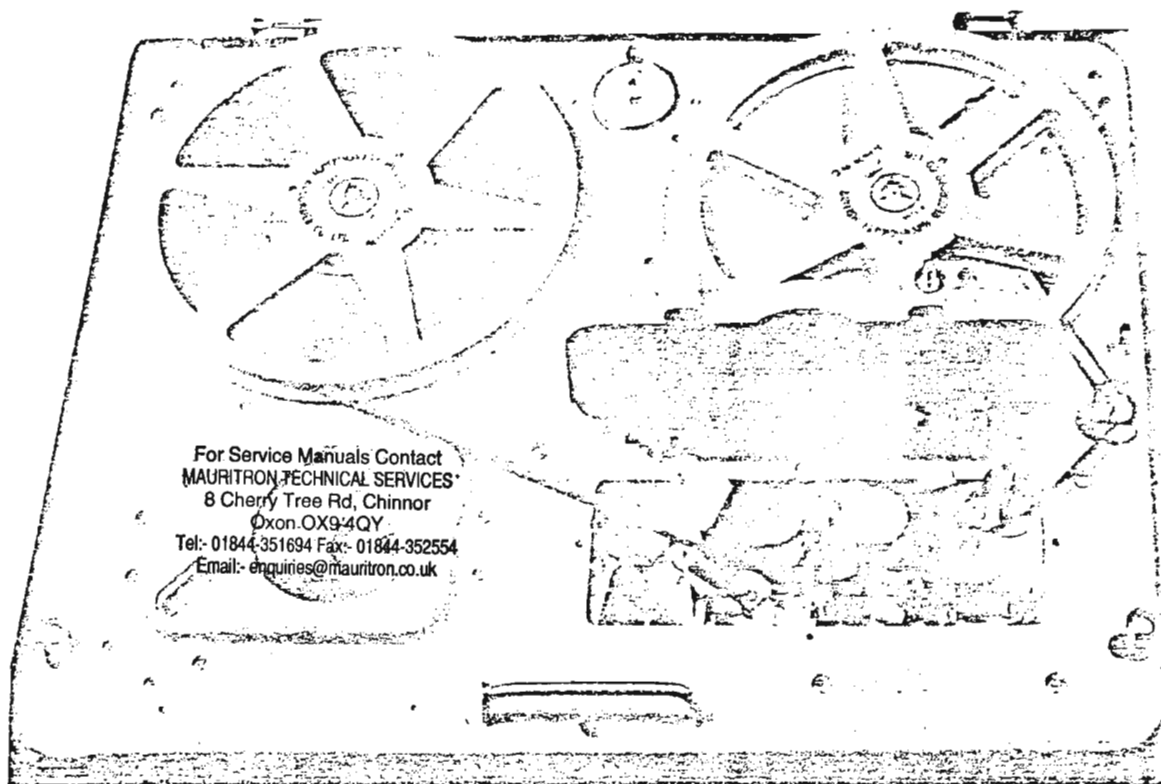

FIG. 4. TAPE LOADING

Turn the main function switch therefore to the "Play" position, start the tape mechanism at the  $7\frac{1}{2}$ " per sec. speed and rotate the gain control clockwise. The test signal should then be heard on the internal speaker. At this stage the operation of the tone controls may be briefly investigated. Counter-clockwise rotation of the left hand knob will gradually remove the bass from the reproduction. The next knob on the other hand controls the upper treble register and will remove the high frequencies. Both these controls are dealt with in greater detail in a later section.

## 5. WINDING BACK AND WINDING ON

To wind back rapidly for playing over again, or to return to the start of a recording it is merely necessary to turn the main function switch to the position where "FAST" and an arrow pointing to the left appear in the knob aperture, then pull the 'run' knob. The amount of tape to wind back is indicated on the dial in the top centre of the deck. The dial mechanism is driven from the take-up motor via a worm gear and flexible cable and has a scale calibrated from 0 to 10 with 10 sub divisions per unit giving 100 small divisions covered by one revolution of the large pointer. At the same time the small pointer moves 10 small divisions to the figure 1 on the scale. The gear ratio is such that one revolution of the take up reel corresponds to a movement of one small division by the large pointer, so that the full scale is equivalent to 1,000 turns, and these and any intermediate number can be read to one turn giving a good cueing indication. A 1,250 feet reel of standard tape will give a total reading of approx. 1,030 on the dial and with "extra play" tape this might further overrun to around 1,500.

A zero setting device is provided, operated by the small external knob projecting from the centre of the dial.

The wind on facility operating in a similar manner, provides a means of rapidly reaching any desired part of a recording in the middle of a reel and will be found of great value.

During both the wind-on and wind-back operations the internal speaker will automatically be silenced.

**Note.** The auto stop switch does not operate during these fast winding operations. It is unnecessary as the instrument should be under supervision throughout the short time involved.

## **6. TO RECORD**

Generally speaking in the average application, one or two sources will provide the material to be recorded :—a radio receiver or a microphone. In the latter case the recording is usually spoken of as “live”.

Two input sockets are available on the “Ferrograph” each providing the best arrangement to deal with the particular source involved.

A characteristic common to all recording is that the erasing head on the machine will be operating throughout this particular process. It is not necessary to load the machine with virgin tape—any reel containing unwanted recordings can be used. The old recording, on the track in operation, will be removed as the new programme material is applied, but the other track will be left unaffected.

### **6.1. Recording from Radio Receivers**

There are several methods which can be employed to inject the radio signal into the recorder. The most popular, since it can be done without modification to the receiver, is by the use of the extension speaker sockets. This, with some other systems, is dealt with in detail below.

#### **6.1.1. Extension Speaker Socket System**

Most modern radio sets have extension speaker sockets brought out at the rear and provide a useful take-off point for a signal. The connexions from these can be made by a length of twisted flex to an unscreened jack plug similar to that supplied with the instrument. The appropriate socket on the recorder in which to insert this plug is then that marked Input 2 (see Fig. 3).

Extension speaker sockets however are themselves of several types. Some are merely placed in parallel with the set's internal speaker and are alive under all conditions.

Others come into operation only by means of a switch which may or may not disconnect the internal speaker. In those cases where the internal speaker of the set is left connected, nothing further need be done except to ensure that when one of the connexions is earthed at the receiver, the same lead is connected to the earthy side of the input plug at the recorder. (This is the longer connection blade under the jack plug cover.)

Where insertion of the extension speaker plugs though requires that the internal speaker shall be disconnected, it will be necessary to connect across the extension leads at some point, either near the set or the "Ferrograph", a resistance equal to the loudspeaker impedance (normally about 3 ohms) so as to maintain the load on the output valve of the receiver.

This done, the desired station should then be tuned in and brought up to a good listening level on the set's own speaker. Any tone controls should be rotated to the normal or highest fidelity positions. With the "Ferrograph's" main selector switch in the "Play Back" position, the extension connection may then be made, when subject to rotation of the instrument's gain control, the programme matter should be audible on the "Ferrograph's" own speaker. A fairly strong signal is desirable from the set so as to be appreciably greater than any hum produced in the receiver's output stage.

If the main selector switch is now turned to the "Record" position, two things will happen. The internal speaker will be silenced and the recording Signal Level Meter in the lower panel will commence to read. Taking these in order, the fact that the recorder's speaker is silenced will be no inconvenience if the receiver's own loudspeaker is working. If it is necessary that the receiver's speaker be silent when the extension facilities are being used, a  $15\Omega$ ,  $\frac{1}{2}$  watt resistor (Fig. 6) could be fitted into an octal plug and this inserted into the octal socket on the front panel (see Fig. 3). This will reconnect the recorder's speaker for monitoring purposes but at a reduced level (the reason for this silencing of the speaker will be discussed later). Unlike the previous models, the present dummy plug cannot be fitted with this resistor and a separate octal plug must be used.

The Signal Level Meter fitted to the Model "4A" "Ferrograph" is of a special pattern. It will have been observed that when not switched on, its pointer occupies the extreme right hand scale position, although the scale at that point reads 10 and not zero. This is intentional, and has been done for a special purpose.

When the main selector switch is turned to "Record" the meter circuit will be energized and in the absence of a signal, the pointer will automatically move to the normal zero position. At this point its zero should be set. To do this the gain control of the recorder should be turned fully counter-clockwise so that no signal is presented to the recording network. The knob marked "Set Zero" (on the panel and not on the meter) should then be rotated slightly in order to make the pointer of the meter coincide approximately with the zero scale mark. If the gain control of the recorder is now turned up the meter will commence to indicate the relative readings



of the material to be recorded. It will be found to climb very rapidly at the commencement of loud passages or short loud signals, but to fall comparatively slowly as softer passages follow. Its object is to provide a means of ensuring that signals of however short duration do not exceed a certain maximum value, indicated by a red graduation at '8' on the meter scale. This is the value which should not be exceeded if a recording of low inherent distortion is to be made.

For many applications, e.g. speech, it is not quite as critical, as the ear is tolerant of a certain amount of distortion in certain cases, but with high quality programme material, careful attention is worth while.

Only the loudest signals should drive the meter up to the specified maximum reading, and the gain control should be manipulated on typically loud passages before actual recording commences that this may be so. Once set, it should not be necessary to readjust the gain control during recording, as the station or studio engineer will be monitoring the programme in a similar manner to prevent overloading the transmitter.

On soft passages the meter may scarcely rise at all but providing that at the same gain control setting it has previously risen to the stated maximum mark, there need be no cause for concern. There is always a tendency at the beginning to turn up the gain control when the meter appears to read very low in a mistaken idea that the programme will not be recorded sufficiently loudly. This must however be resisted, as it will be found that when a loud passage subsequently comes along, overloading will result. Once the recording is overloaded, turning down the gain control during playback will not remove any distortion which might have been introduced.

Having thus ascertained that the receiver is properly tuned in and that the signal level is correct, the tape may be started and the recording proper commenced. Its point of commencement should be noted on the scale, so that it may be returned to without difficulty for playback.

#### **6.1.2. Direct from Detector System**

The method described above is perfectly satisfactory from well designed receivers. Cases may arise however where poorly filtered H.T. supply systems may cause hum to be generated in the receiver's output stage, and although this may not be unduly noticeable on the set's own speaker, the superior low frequency response of the "Ferrograph" may make it a source of annoyance.

A better method exists for those who are able to employ it, which involves taking the output for injection into the "Ferrograph" immediately after the receiver's detector stage. This avoids using the receiver's output stages, which are unnecessary so far as the "Ferrograph" is concerned, and avoids the distortion and hum normally associated with such stages. Here the signal will normally be of a lower level, and may be taken into Input 1 socket of the recorder if adequate gain is not provided at Input 2. If the right hand socket is used, and the lead from the detector stage is

coming off at high impedance, it will be necessary to insert a shorting plug in the left hand socket (see technical notes on circuitry).

In the same category of radio recording may be included the use of specially designed high quality tuning units, which can be powered from the octal socket at the front of the instrument provided that their supply requirements do not exceed the figures given in Para. 11 (Auxiliary Sockets). In general, this will apply to most "AM" tuner units, but not to the "FM" variety, which usually have their own power supply.

When not in use the socket is covered by a plug fitted with a cap resembling a control knob. This knob, with its plug, should be pulled out when the auxiliary socket is required for use.

A popular tuner unit uses a straight aerial and H.F. section followed by an infinite impedance detector. As it has no output stage monitoring during recording is usually carried out either through the 15 ohm extension speaker socket or through the internal speaker, which may be made live by a demuting resistor incorporated in the octal plug. (see Fig 6).

### **6.1.3. Microphone Method**

Although hardly worthy of mention as a serious means of recording, this is included for the sake of completeness. It is a method which should be used only in the last resort when the others are completely out of the question, or when special effects are required. It involves the use of a microphone placed near the loudspeaker of the receiver while it is operating normally. This brings it almost into the category of a live recording and substantially the same remarks apply. It is therefore largely dealt with under this heading.

## **6.2. Gramophone Record Transcriptions**

Where a standard radio gramophone is involved the technique of transcribing gramophone records will be exactly similar to that described above for radio recording insofar as the connections to the recorder are concerned, and the adjustment of recording level. It is also possible though to take the connections from the pick-up directly into the "Ferroglyph" providing that the appropriate low frequency tone correction network recommended by the makers of the pick-up is included in the lead between it and the instrument.

## **6.3. Live Recording**

Live recording involves the use of a microphone and a somewhat different technique, and greater attention to detail is required for optimum results. The quality of the final recording will depend amongst other things upon the type of microphone used, the acoustics of the room involved, and its placing therein. A certain amount of experiment may be necessary with the last of these factors before the very best arrangement is found, but this of course is no great hardship with magnetic recording as during the initial tests none of the medium is permanently consumed.

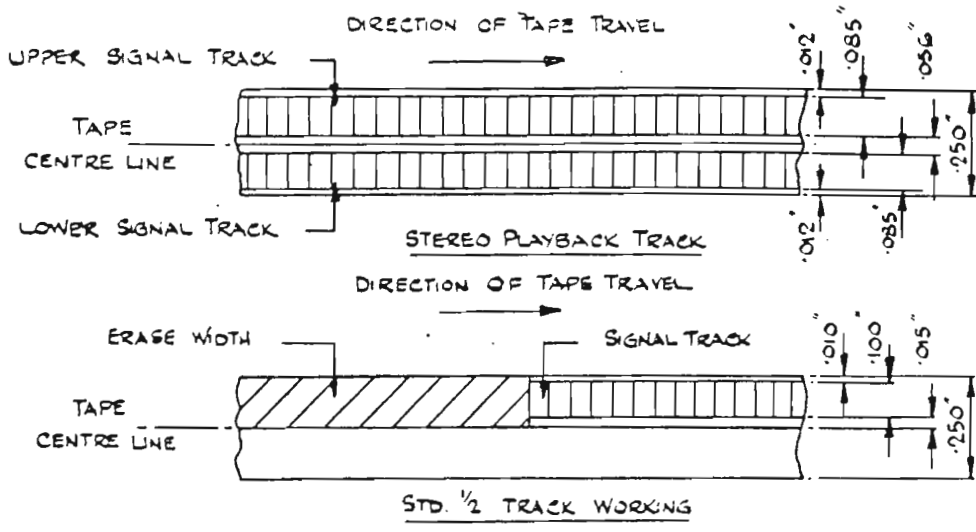

STD. 1/2 TRACK WORKING  
 FIG. 5 TRACK DISPOSITIONS.

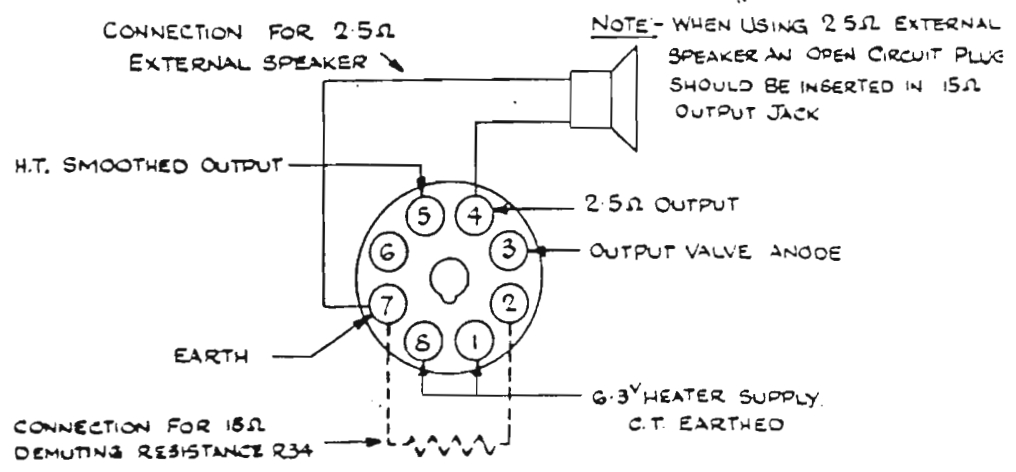

FIG 6 AUX SOCKET 1 WIRING  
 (VIEWED FROM ABOVE)

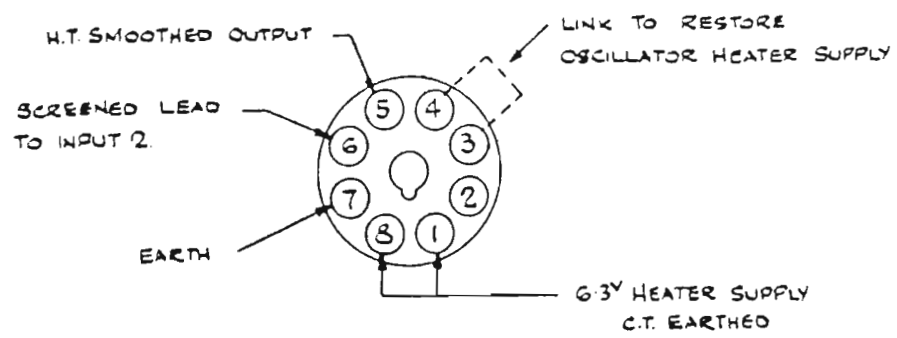

FIG. 7 AUX SOCKET 2 WIRING.  
 (VIEWED FROM ABOVE)

There are several types of microphone which may be used with the "Ferrograph" ranging from the cheap diaphragm crystal types, through the medium priced dynamics and multi-crystals, to the very expensive moving coil or ribbon dynamics. There is little point in purchasing microphones having a frequency response greatly in excess of the instrument itself and which may cost almost as much. At the same time it is equally without point unnecessarily to restrict the overall fidelity by the use of the very cheapest. Generally speaking, having regard to all the factors involved, the most suitable for general purposes is undoubtedly the medium priced low impedance moving coil or ribbon microphone. A type of the latter exceptionally well suited to the "Ferrograph" is included in its list of accessories. The matching transformer necessary is also listed.

The great advantage of the low impedance version is that long leads (up to 40 ft.) may be used without picking up unwanted hum, providing the matching transformer is used close to the recorder. High impedance moving coil and crystal microphones may be used, but some care will be necessary with the screening of the cable and connections and it is not normally practicable to operate these with very long leads because of hum troubles. Because of the relatively low output voltage delivered by microphones they will always require to be plugged into the left hand socket (see Fig. 3).

It is during live recording that the necessity arises for silencing the internal speaker to prevent acoustic feedback, particularly where the machine and microphone are in the same room. This takes the form of a howl as the noise from the speaker feeds back into the microphone, is itself amplified and transmitted again through the speaker in a vicious circle, gradually building up in volume. It will happen if the external 15 ohm speaker is left in circuit while the microphone is plugged in. It should accordingly always be removed when any sound from it is likely to reach the microphone. The demuting plug however can usually be employed to provide a greatly reduced signal for monitoring on the "Ferrograph's" own speaker, and trouble should not be experienced if reasonable spacing precautions are taken. It is always desirable during recording to keep the instrument as far away from the microphone as possible as a certain amount of mechanical noise or vibration from the machine is inevitable and where the highest quality recordings are sought, it is undesirable that even the faintest unnecessary noise should be present.

The chief point of difference in the operation of the recorder itself, between live recording and recording from a radio signal, is that the studio control of dynamic range usual in the latter is not present. This means that somewhat more attention will need to be paid to the signal level meter and the gain control. Because the dynamic range of certain programme material may exceed that of the tape, a certain amount of volume compression may be necessary. This means reducing the level of the loudest passages and increasing that of the weakest so that the former shall not overload the tape or the latter be lost in the background noise.

With regard to the detailed use of the microphones themselves, individual manufacturers will issue appropriate instructions depending upon type and whether or not they are directional. Here detailed consideration will be given only to the models listed among the accessories.

This is a ribbon microphone carrying within its case a transformer matching the ribbon to a 30 ohm line. It is available with a floor, table or desk stand. Long cables may be used providing a microphone matching unit is used. Its frequency response is entirely level over the range of the model 4A "Ferrograph" and is suitable for all forms of speech and musical recording. The microphone head is tablet shaped and may be inclined backward on its mounting. Although it is largely modified by wall and ceiling reflections in normal rooms, under free field conditions the microphone has very little pick-up of sounds originating at the sides, consequently it can be of great value in suppressing unwanted noise.

When it is being used for speech it should be addressed frontally but very close talking should be avoided as this causes bass accentuation with ribbon types. The optimum distance is about 12". Should closer usage be necessary because of high local noise, speaking should take place across the front at a minimum of 3". When recording speech with any microphone, an apparent lack of sensitivity might be noted, in that a high setting of the gain control for peak level compared to that required for singing or music is necessary. This is mainly due to the peak level meter not following the short duration "spiky" speech waveform. Accordingly, concern need not arise if the meter fails to reach 8, as much lower average readings will be found to give a good recorded level.

Generally speaking it is undesirable to use any microphone very closely particularly if it has been kept in a cold room, for condensation may temporarily affect the performance and if continued, may cause corrosion.

Finally, the microphone should be treated with the care it deserves; never leave it where it may come into contact with steel dust as it incorporates powerful magnets.

#### **6.4 Recording from 600 ohm lines**

Input 2 of the instrument will adequately handle the 77v. of 1 milliwatt in 600 ohm lines, and the input plug may in these circumstances be terminated accordingly. The input circuit thus provided will not be balanced to ground, but a 1-1 balanced to unbalanced transformer unit embodying the appropriate jack is available. If the input plug is terminated with 600 ohms it will not be necessary to insert the shorting plug in the left hand socket. (See notes on circuit design.)

#### **6.5. Simultaneous, Live and Relayed Recording**

It is sometimes useful to be able to record from two sources at the same time without going to the lengths of a separate mixer unit. For example, a spoken commentary may be required during the transcription of a radio programme or gramophone record. This may be done using the left hand socket for the microphone and the right hand for the relayed material, providing that the input to the latter is arranged to come from a high impedance source, and its level controlled independently of the "Ferrograph". In the case of extension speaker socket systems the first requirement can be met by connecting in series with the ungrounded lead to the jack plug and as close to it as possible, a resistance of approximately 200,000 ohms. This should of course be *after* any low resistance necessary to replace the receiver's speaker load.

## 7. BRIEF STOP

When making a series of short recordings it may be noticed that a slight click is put on the tape at the start and finish of each recording. Normally this is of little consequence and can be ignored. It can be eliminated however, by the use of the 'brief' stop, the operating button of which is shown in Fig. 3. The action of depressing this, pushes the pinch roller off the capstan and holds the tape against the right hand guide peg, stopping the movement of the tape immediately. The housing of the button has a standard camera thread, so that a shutter release cable can be screwed on for remote operation if desired.

## 8. TO PLAY BACK AFTER RECORDING

As the same amplifier suitably switched is used both for recording and playing back, it is necessary to remove all the input plugs from the front of the unit before this latter operation is possible. It is as well to withdraw them while winding back is taking place. Having wound back to commencement of the recording, the switch can be turned to the "Play Back" position and reproduction then commenced.

A 10" x 6" elliptical speaker is built into the "Ferrograph" to deliver the sound output, and is capable of very good reproduction. Certain limitations are however inherent in built-in speakers as the small size of the cabinet does not allow exceptional acoustic treatment at the lower frequencies. Where a better acoustic standard is sought, recourse can always be had to larger speakers in special cabinets. The general performance of the machine certainly warrants their use—subject to the note below—and a 15 ohm extension speaker jack socket has been provided at the lower right hand front panel. It is to this socket, suitably terminated, that all measurements and specifications of frequency response, distortion and output power relate.

Insertion of the extension speaker plug will automatically disconnect the internal speaker. If necessary a 2.5 ohm extension speaker can also be accommodated, and the connexions for this are shown in Fig. 6.

It will be necessary to insert an unconnected plug into the 15 ohm outlet socket so as to cut off the internal speaker.

### 8.1. The Use of the Tone Controls

While for many engineering applications the recorder is required to be operated as a strictly linear device, reproducing electrically the original signal as nearly as possible, in the important general case where the output is listened to directly over a loudspeaker, some ability to modify the frequency spectrum (or tone) is desirable. Here the loudspeaker and the human ear cannot be ignored but must be considered as part of the reproducing chain. Now the ear is known to have some very peculiar characteristics. Thus for example if a complex sound is played at different levels of loudness the ear will not perceive the individual frequency components making up the tone, always in the same ratio. As the sound intensity is increased, the low notes gradually will seem to become more prominent.

The effect of this phenomenon in recording is that under linear conditions, unless the reproduction is played back at the same sound level as the original, it will not sound

exactly the same. Speech is quite commonly played back a good deal more loudly than the original, in consequence it often sounds somewhat boomy. It is here that the bass control is properly brought into play to remove the undue emphasis.

Again, to preserve naturalness, an extended bass response is out of place unless balanced by a corresponding extension of the higher frequencies about a certain mid value. Consequently if for any reason the high frequency response has to be restricted, e.g. a hiss from disc or radio, a proportionate cut in bass can be made to restore the naturalness of the reproduction.

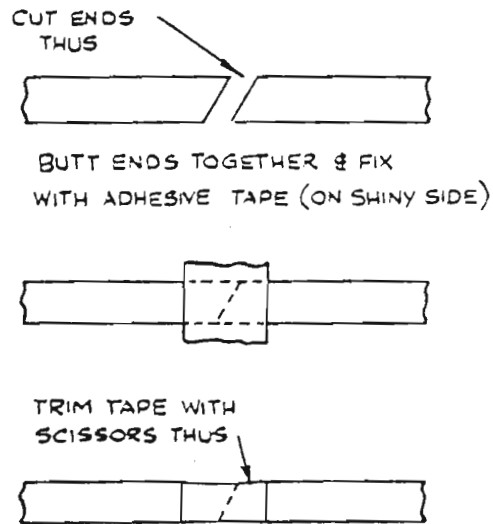

FIG 8 TAPE SPLICING.

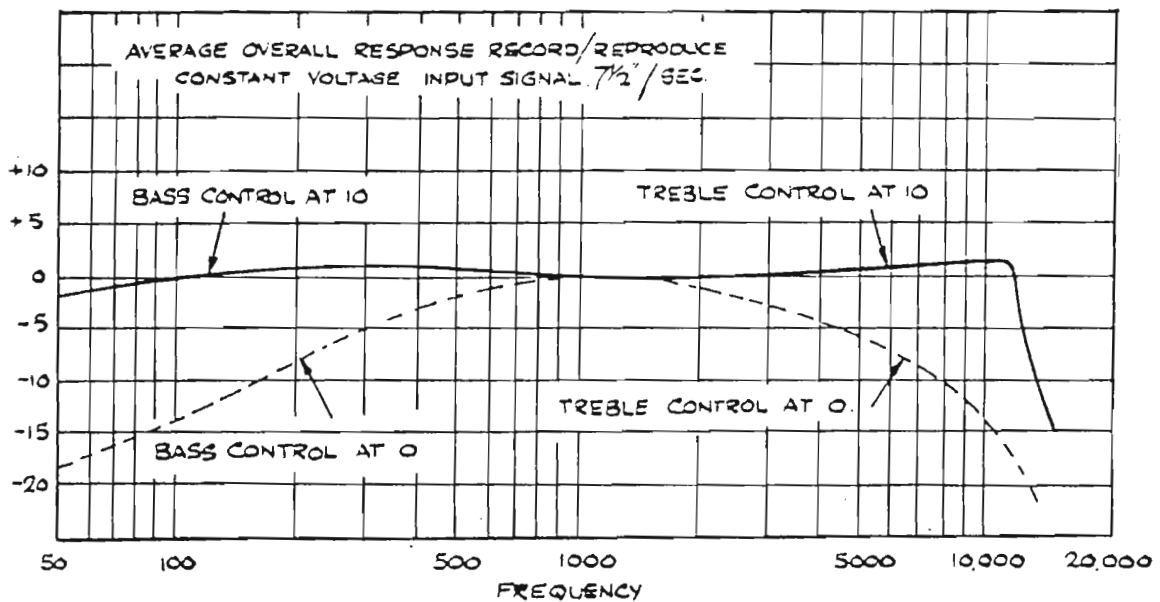

FIG. 9

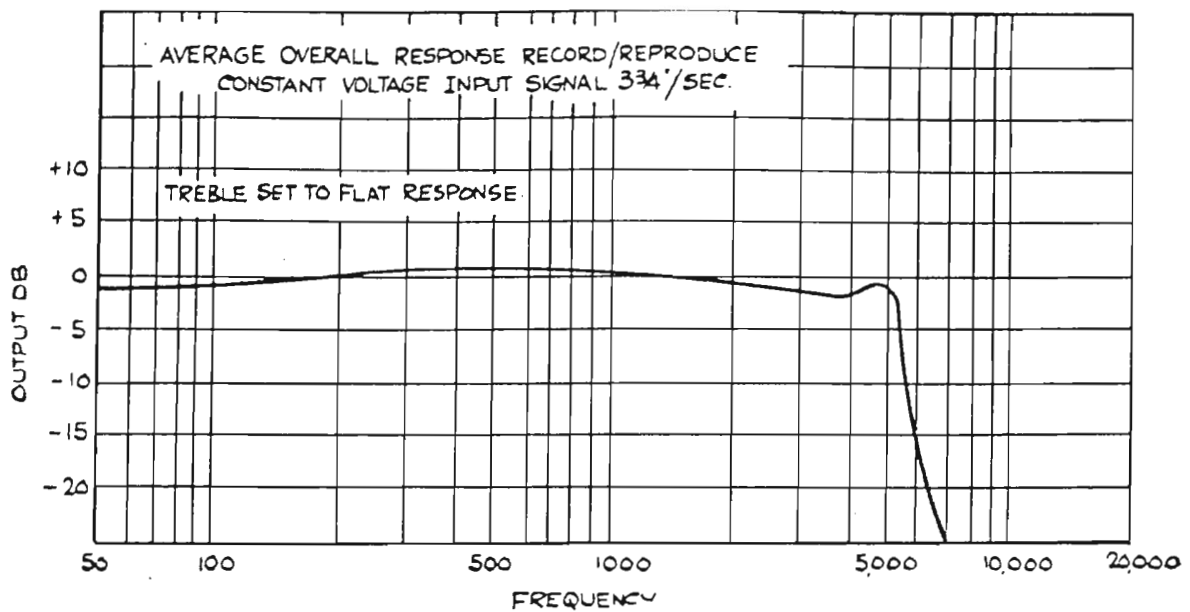

FIG. 10.

The high frequency tone control operates from about 2000 c.p.s. upwards. The pre-set controls inside the instrument are adjusted at the factory so that a level high frequency output is obtained when this control is set to the fully clockwise position.

## 8.2. To play back over other Amplifiers, Disc Recorders, etc.

Occasions often arise where it is desirable to play back recordings over existing sound distribution networks, P.A. systems, etc. Alternatively it may be necessary to feed the output into a disc recorder for dubbing purposes. In both cases adequate provision has been made in the 15 ohm outlet socket. No fear need be entertained here that the remarks concerning receiver output apply. The output stage necessarily has had to receive special attention as it is part of the recording amplifier. The only precaution to be observed is that the plug employed to take off the output shall be shunted with a 15 ohm resistor to provide the load on the output valve, as the internal speaker will be disconnected by its insertion. Comfortable peak output levels of 3 volts or so are obtainable in this way. Should this be greatly in excess of the requirements, it is better to attenuate it by tapping off the 15 ohm resistor than by too drastic use of the instrument's gain control.

In cases where the use of this low impedance output is undesirable—and indeed they are very few—it is possible to abstract a signal at high impedance before the output stage of the amplifier. It is obtainable at Input 2 (acting as an output) and provides approximately 75v. peak across an effective impedance of approximately 100,000 ohms. It is not subject to the instrument's gain control here, and since it is merely in parallel with the V.3 grid (see circuit) the load into which it feeds should not be less than 2 megohms. In this application of course, a shorting plug must not be inserted in the left hand socket

NOTE.—Such equipment invariably will be earthed at some point or other, which means that by its connection the "Ferrograph" also will be earthed indirectly. As it incorporates a very high gain audio amplifier, it may be found that on certain mains



input connections to the "Ferrograph" will almost always effect a cure. In the same way under other conditions and mains supplies, it may be found that a common earth connection will reduce any slight residual electrostatic hum pick-up. In any case it is always worth while trying the effect of reversing the mains leads and noting its effect on residual hum level.

## 9. TO ERASE UNWANTED RECORDING

It must be borne in mind that when the main selector switch is in the "Record" position the oscillator supplying the erasing head is energised and that if the tape is run in this position, any previous signal on it will be erased. Accordingly the switch should be turned to this position only when it is desired to make a new recording or when the erasing facility is purposely required. To erase unwanted material without impressing a new signal, the tape should be run in the "Record" position over the desired length with the gain control at zero. Failure to turn the gain control to zero may result in a whistle being put on the tape in the place of the original signal, due to amplifier instability in the absence of an input plug. Erasing by this means deals with only one track of the tape, the other track is completely unaffected.

There is another method of erasing small excerpts—not to be highly recommended—which involves passing the particular piece of tape concerned over a small permanent magnet. This naturally affects both tracks since its field cannot be confined. It also leaves the particular piece of tape with a relatively high background noise. Recordings may also be erased from tape in bulk while on the reels, by a special bulk eraser.

## 10. THE ERASE LINK

At the rear panel of the instrument will be found a small shorting plug in a socket marked "Erase Link". This has a two-fold purpose.

Firstly, by the removal of the plug, it ensures that the recordings cannot be accidentally erased. This it does by severing the connection between the erasing oscillator output and the deck. It will be found of great value where the recorder is to be used by the relatively unskilled, for the purpose of repetitive playback only of valuable recordings.

The second function of this link is to provide a means of interjecting spoken commentaries into existing recordings without the clicks and sudden discontinuities which usually occur when this is attempted by merely turning to "Record", interjecting, and switching back to "Playback".

The object of the present system is to provide a gradual but complete fade out of the previously recorded material, a smooth insertion of the new material, followed by a gradual restoration of the original. This is achieved by plugging in to the erase link socket a new plug to the pins of which is attached, by a foot or so of twin lead, a 1,000 ohm wirewound rheostat of 4 watts dissipation and with a logarithmic characteristic.

Having then carefully noted by time interval or scale marking, the positions at which the interjection is required, the recorder is started, carefully set for the new recording level in the

“Record” position, but with the variable resistor mentioned set to the maximum position. Running in this way, no erasing will take place.

As soon as the appropriate point is reached, the variable resistor is slowly rotated to its zero resistance position. At this point both the erase and the bias will be fully operative, the old material will have been faded out and the new can be inserted. When finished, the resistor should be slowly rotated once more to its maximum position.

It goes without saying of course that it is not necessary to use this method only when an interjection is required. It can readily be used to delete unwanted portions of a recording in an inobtrusive manner.

## **11. THE AUXILIARY SOCKETS**

To increase its scope, the Ferrograph is provided with two international octal (valve base) auxiliary sockets, to which various internal connections are taken.

### **11.1. Auxiliary Socket 1**

This is located on the right of the front panel and is normally covered by a ‘dummy knob’ octal plug. From it may be taken both HT and LT supplies for powering ancillaries such as tuner units, mixers, etc. The appropriate connections are shown in Fig. 6 and it should be noted that the LT winding has its centre tap connected to chassis.

During recording, 1 amp of LT, and 15mA of HT may be taken from this socket, with an increase to 40mA of HT current under playback conditions only. Also on this socket are connections for a 2.5 to 3 ohm external speaker and for ‘demuting’ the internal speaker when recording.

### **11.2. Auxiliary Socket 2**

This will be found on the rear panel and it has a power supply function similar to auxiliary socket 1, but with special reference to the Ferrograph ‘Stere-ad’ unit. Other connections include a screened lead to input 2 and the oscillator valve heater supply. The latter is taken to two separate pins which must be bridged by a link in the octal plug provided before the bias and erase oscillator will work for recording. When the Stere-ad unit is plugged in, this link is omitted in its plug so that the oscillator valve heater consumption is saved.

**BECAUSE OF ITS POWER REQUIREMENTS, SEVERE OVERLOADING WILL OCCUR IF ADDITIONAL EXTERNAL POWER IS TAKEN FROM AUX. SOCKET 1, WHEN THE STERE-AD UNIT IS IN USE.**

## **12. TO CHANGE TRACKS**

The manner in which the tracks are disposed upon the tape is shown in Fig. 5. The advantage of this system is that two tracks can be accommodated side by side, thereby doubling the length of playing time per reel. In practice the system is operated in this way. After a full half hour’s recording has been made upon the top track in the normal way, the magazine reel

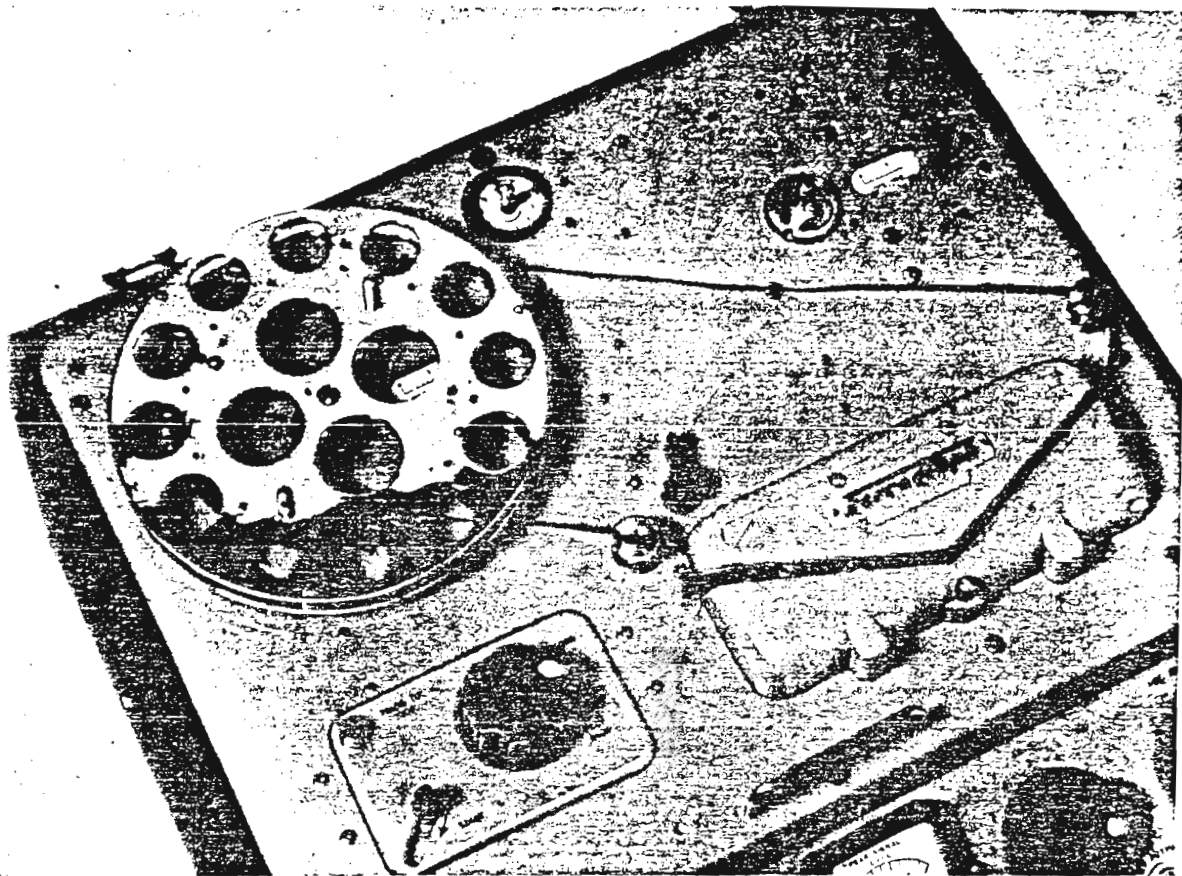

FIG. 11. TAPE DECK CONVERTED TO LOOP OPERATION

will be empty and all the tape will be on the take-up reel. The reels are then removed and the full reel is inverted on to the magazine spindle. The empty reel taken from this position is moved to the take-up spindle. The full magazine is henceforth treated in the same manner as a straightforward unrecorded reel. After the second track has been fully recorded the tape will of course be found to be wound back on to the take-up spool in such a way that if the reels are again transposed, immediate playback at the start of the first track is possible. One hour's recording or playback is therefore available at  $7\frac{1}{2}$ " per second with a break of only a few seconds half way, for the reel transposing operation.

Although not intended to be a requirement of the machine, it is also possible with a little practice, to remove the tape reels half way through a track and change over. To do this it is necessary to open the tape gates with the main selector switch, open the head cover and lift it out.

### 13. EDITING AND SPLICING TAPE

One of the great advantages of tape recording is that it is easily edited. Unwanted passages may be cut out and the ends rejoined. Composite programmes of selected material may be built up in this way. It is of course impossible to edit one track only, as cutting out pieces of the tape obviously affects both tracks. However once the editing has been done for the single track, the composite tape may be put back on the machine and the other track recorded in the normal way with material which does not require editing.

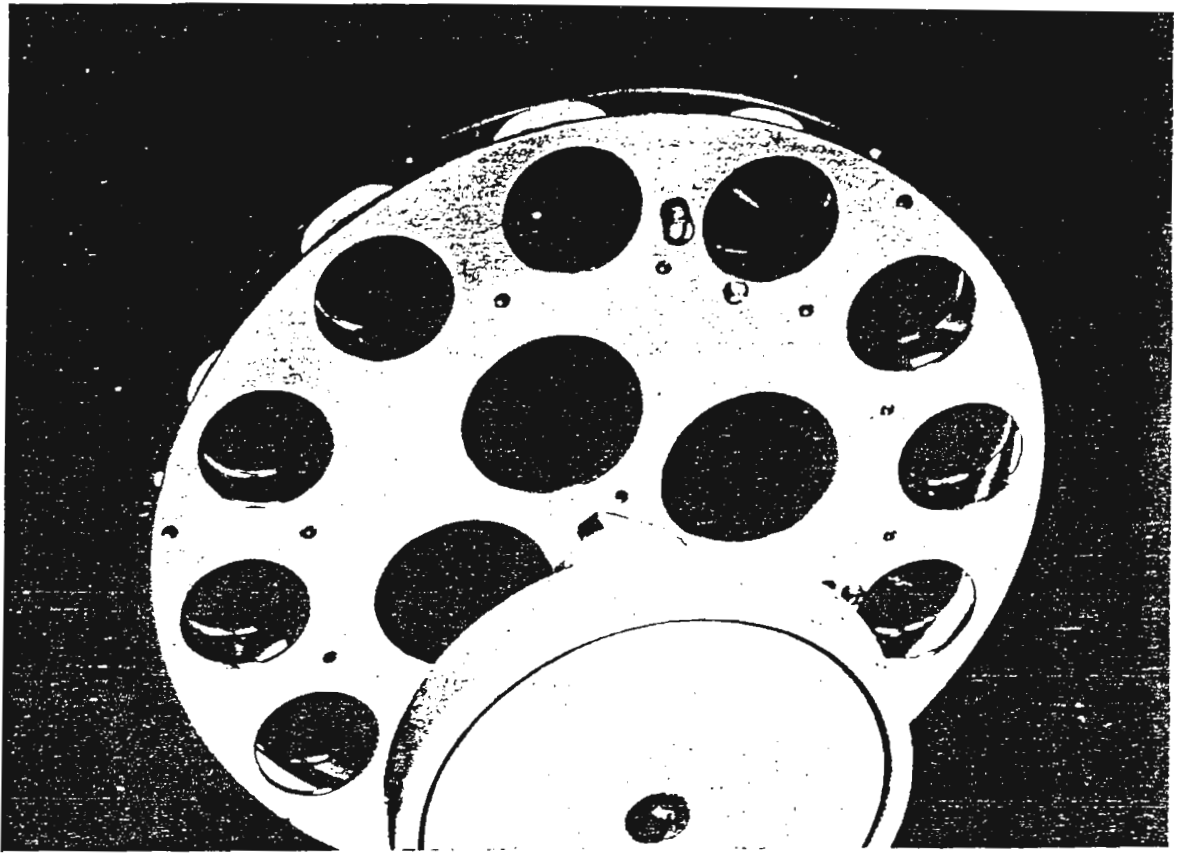

FIG. 12. LOADING OF LOOP CASSETTE

Splicing and joining of the ends of cut or broken tape is normally carried out by means of transparent adhesive tape applied to the back i.e. the shiny side of the tape. Fig. 8 makes clear the method of doing this.

#### 14. SPOOLS

Several sizes of spools are available as follows :—

200 ft.	giving	5 mins.	per track	at	7½" p.s.
600 ft.	„	15 „	„ „	„	„
1200 ft.	„	30 „	„ „	„	„
1750 ft.	„	45 „	„ „	„	„

The ability to take the last mentioned large reel, which is a feature of the Series 4 “Ferrograph” will be found of the greatest use, particularly to music-lovers where it will enable many more whole works to be recorded without a break, on one track.

It should be noted however that the large reels of necessity slightly overhang the deck and it is not possible to replace the lid of the instrument with these reels in position. For the same reason no attempt should be made to hinge back the deck when these reels are fitted.

## 15. ENDLESS LOOPS

The "Ferrograph" finds many applications in science and industry where special problems present themselves. Some of these do not require long recording sequences in the normal way but instead an endless band of tape for continuous presentation of data or for continuous recording. A loop of a few minutes' duration is usually adequate in such circumstances and the cassette attachment about to be described (which is an optional extra) caters for a maximum of 4 mins. at  $7\frac{1}{2}$ " per sec. or 8 mins. at  $3\frac{3}{4}$ " per sec. Under the continuous recording conditions referred to above any activity capable of translation into an electrical phenomenon within the frequency and phase shift limitations can be monitored, so that the last few minutes are always on record. In this way the instrument can be made to act as a memory loop and if necessary its memory can be shortened to a matter of a few seconds. Monitoring for fault conditions is an obvious application of the facility, as immediately a fault occurs it can be arranged that either automatically or manually the deck is shut down so that afterwards on playback, the conditions leading up to the establishment of the fault can readily be traced.

When making the conversion to endless loop operation the take-up and magazine motors must be disconnected so that they do not revolve. This can be done by breaking the link on the right hand tagboard of the deck, between the tags marked 0 and 5.

The cassette is then attached by means of captive screws to the hank bushes rivetted to the deck under the magazine reel. Fig. 12 shows the cassette in position. Before attachment it will of course be necessary to load the cassette with the required amount of tape. It is not wise to exceed 4 mins. running time at  $7\frac{1}{2}$ " per sec. or 8 mins. at  $3\frac{3}{4}$ " per sec. so bearing in mind that at these speeds the tape velocity is  $37\frac{1}{2}$  and  $18\frac{3}{4}$  ft. per min. respectively, the appropriate length should be cut from a reel of well aged acetate based tape (not PVC). The three screws and their spacers around the periphery of the cassette should be removed and the small peg inserted in the way shown in Fig. 12. The start of the tape should be passed from the outside through to the inside of the cassette over the fourth roller, counted in a counter-clockwise direction from the peg, and the winding should proceed in a conventional "coating inside" manner over the peg as shown in Fig. 12.

The purpose of the peg is to ensure that when it is removed the tape is left very loosely wound in the cassette. It must of course be removed before any attempt is made to operate the machine and the peripheral spacers must also be replaced. The Fig. shows the cassette being wound on a conventional cine-film winding attachment which provides a convenient means of carrying out the operation. After winding, the ends of the tape should be spliced together, leaving a loop of approximately 18".

In operation the tape will be pulled out of the inside of the cassette and by virtue of the inter-turn friction the whole mass of tape will revolve easily on the anodised surface and the rollers, and wind itself again on the outside.

When first run after loading on to the machine, the winding tension will adjust itself automatically to the correct inter-turn friction and the length of the free loop will vary accordingly. Normally it will increase in length as the tape tightens up and after the loop has been running for some few minutes the tape can then be re-spliced at the original join to bring the

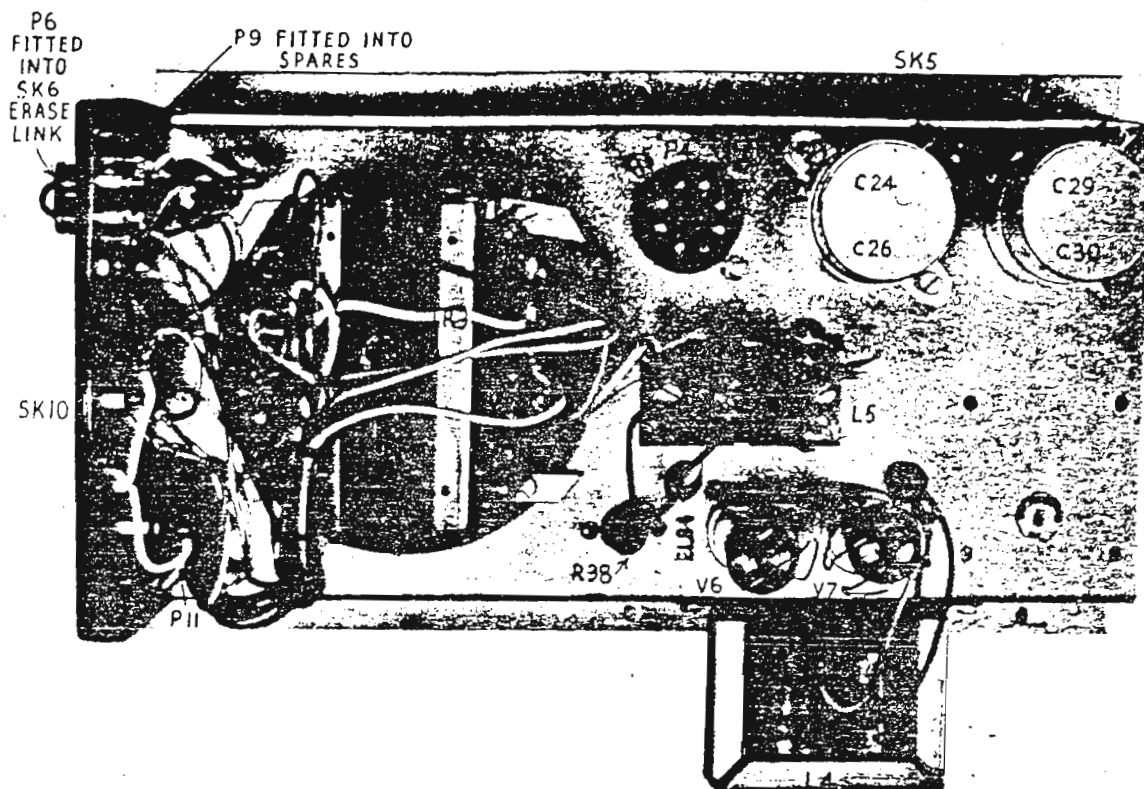

FIG. 13. POWER UNIT, TOP VIEW

free loop within the confines of the deck. It must not be made too small as otherwise the tape may bind in the cassette. Fig. 11 shows a typical loop in operation.

Where the loop is being loaded with previously recorded material obviously the length cannot be shortened haphazardly and therefore to take up the loop length, the splice must be undone and further turns taken round the cassette before re-joining.

## 16. STORAGE OF RECORDINGS

Where a library is being compiled, or where individual recordings have to be stored for indefinite periods, care should be taken to see that the tape is wound evenly and fairly tightly on the reels before storage. Do not keep them where they are likely to be subjected to heat, mechanical vibration or magnetic fields. Above all protect the reels from damage—buckled reels can cause “wow” if they scrape on the deck, or an unpleasant mechanical noise as the tape rubs past their bent edges.

## 17. CARE AND MAINTENANCE

Little actual maintenance is necessary with the “Ferrograph” beyond the periodic removal of dust and dirt from the head assembly. After a time a deposit from the tape will form on the working surface of the heads and unless removed, may impair the frequency response.

For Service Manuals Contact  
MAURITRON TECHNICAL SERVICES  
8 Cherry Tree Rd, Chinnor  
Oxon OX9 4QY  
Tel:- 01844-351694 Fax:- 01844-352554  
Email:- enquiries@mauratron.co.uk

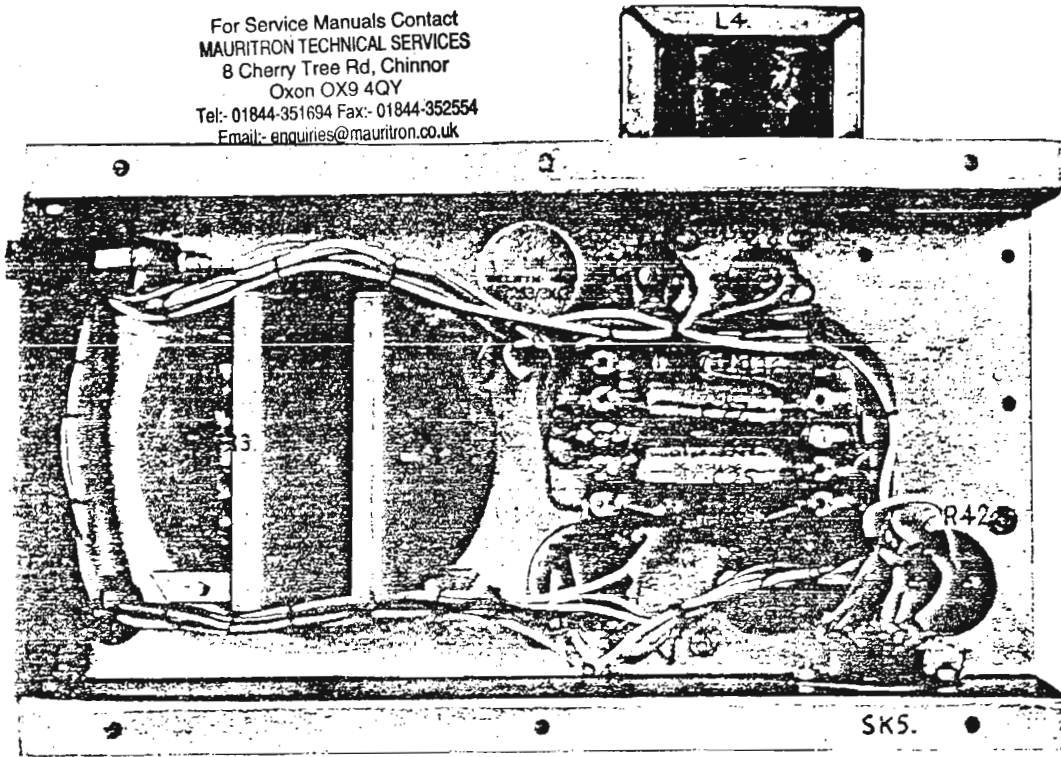

FIG. 14. POWER UNIT UNDERSIDE VIEW

To reach the heads it is only necessary to open the head cover box. A small brush is provided for the cleaning operation and it should be gently used. It is best applied while the pressure pads are deflected to their full extent with the fingers, the gate mechanism of course being open.

The record/reproducing head is a very vital part and its working face should be treated with great care. After a time it will have acquired a very high polish, and this is a very desirable condition to be maintained. Never allow any abrasives to come into contact with it, and never approach it with steel tools which may have become magnetised. Furthermore never attempt to remove the cylindrical cans of the heads themselves, as the gap setting or the alignment of the head faces may be upset with serious results.

The capstan also requires great care to see that its surface remains undamaged. Here too tape coating material and dirt may accumulate causing "wow", or the tape to pull but weakly. New tape quickly leaves a fine deposit so that periodically, or whenever it is suspected of causing poor tape transport, the capstan surface should be wiped with a dry cloth. If allowed to accumulate for too long, a VERY LIGHTLY damped cloth may be necessary.

**DO NOT CARRY OUT THIS OPERATION WITH THE CAPSTAN RUNNING AS THERE IS GRAVE DANGER OF THE CLOTH BECOMING CAUGHT AND CAUSING DAMAGE TO THE CAPSTAN.**

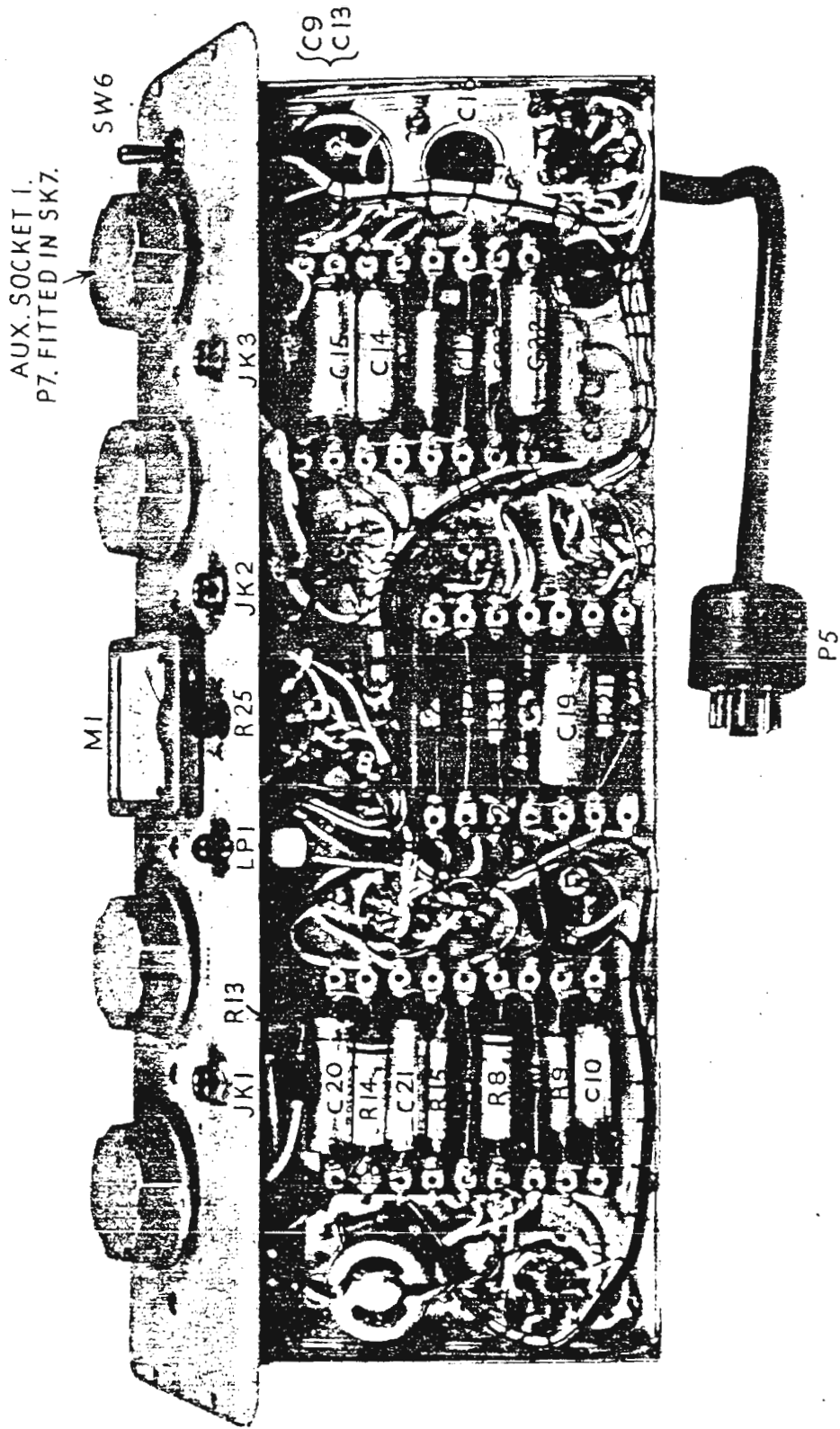

FIG. 15. AMPLIFIER UNDERSIDE VIEW



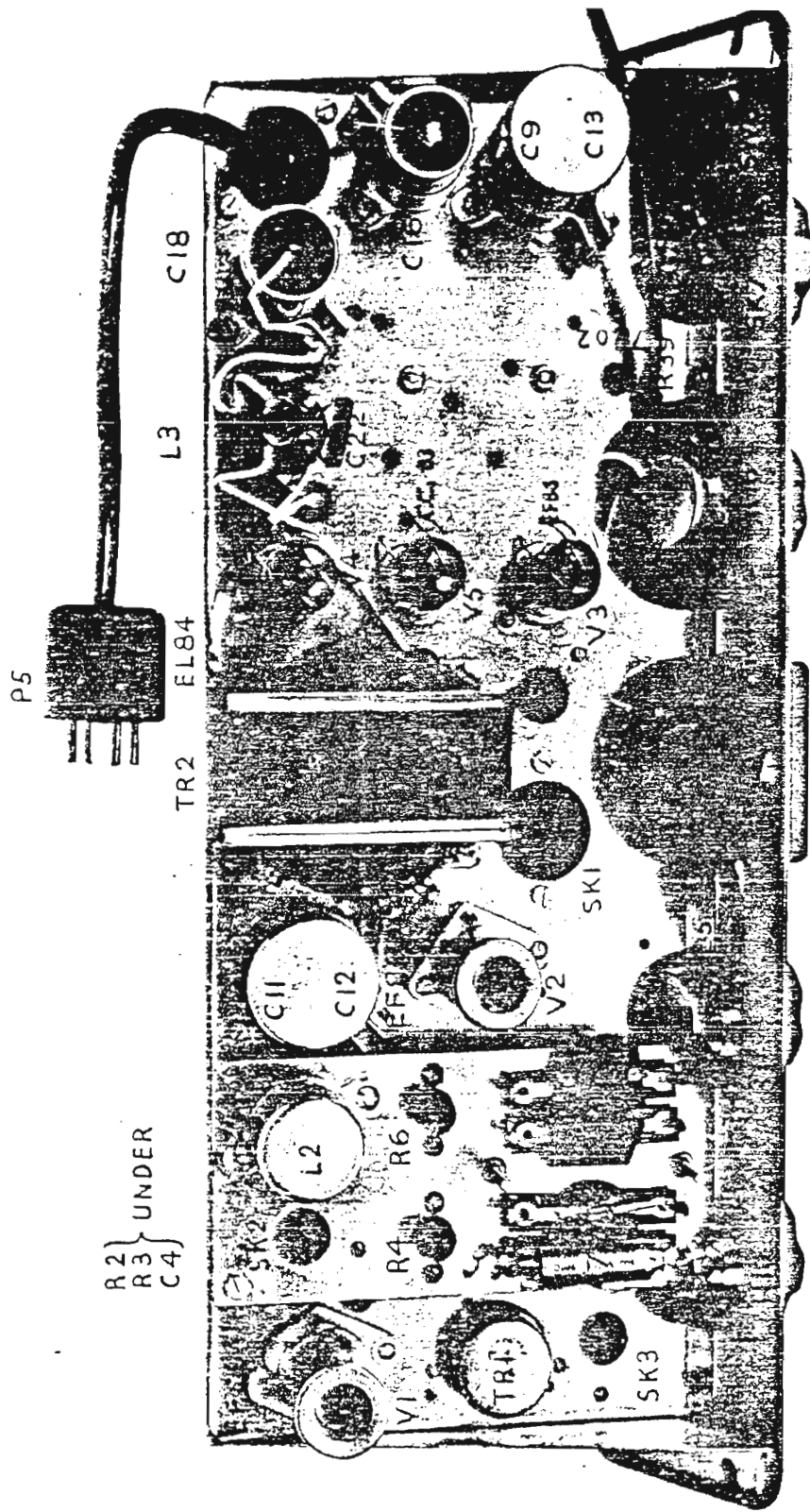

FIG. 16 AMPLIFIER, TOP VIEW

For Service Manuals Contact  
**MAURITRON TECHNICAL SERVICES**  
 8 Cherry Tree Rd, Chinnor  
 Oxon OX9 4QY  
 Tel:- 01844-351694 Fax:- 01844-352554  
 Email:- enquiries@mauritron.co.uk

All rotating parts of the tape deck are fitted either with self oiling bronze bearings or grease packed ball races. The latter require no regular attention and the former should run for approximately 1,000 hours before any oil need be applied. To do this, a few drops of Aeroshell fluid number 3 should be introduced into the top and bottom bearings of each motor with a suitable 'dropper', taking great care not to splash either the brake shoes or the idler wheels. If difficulty is experienced in obtaining this particular oil, it can be supplied in a small container as an accessory.

If bad noise or stiffness suggest its desirability, a trace of oil can be applied from time to time to the sliding members of the gate mechanism and the pinch roller bearing, but under no circumstances should oil or grease be allowed to come into contact with the neoprene face of the capstan.

Adjusters have been fitted to the reel brake shoes so that any unbalance in the reel braking can be compensated. The brakes are self-wrapping in one direction and are arranged so that this is the direction in which the reel is unwound. Consequently this reel has the greater braking torque applied and tape spillage is prevented. Should there be any overrun, or should the reels take an undue time to come to rest, the screw of the appropriate adjuster should be undone and moved away from the reel spindle to increase braking torque, or towards it to reduce it.

Apart from such tasks as replacing fuses if necessary, this is about as far as the unskilled should go in the matter of adjustment. Anything further, needing for example adjustments under the deck or base plate, should be left to the approved service engineers who have the necessary specialized instruments for the correct setting.

The manufacturers can accept no responsibility for faulty performance caused by tampering with the settings of any internal components or controls.

## 18. TECHNICAL NOTES ON CIRCUITRY

A full theoretical circuit is given in Fig. 20, but the following notes are appended by way of amplification of some of the less obvious points which may have a bearing on certain engineering applications.

### 18.1. Recording Amplifier

During recording the first valve V.1 is not used. Insertion of the plug into the Input 1 jack disconnects the feed from it and its associated frequency correction network. This is done so that any hum or noise generated in the first stage shall not be passed on to the succeeding stages.

Input 2 is between V.2 and V.3 but is not of the switched pattern as it is required for abstracting signals from previous stages in addition to providing the higher level input feed. This socket is principally intended to work from low impedance sources, e.g. 600 ohm lines and extension speaker connexions, where during recording the previous stages will be effectively shorted down and their local noise thereby nullified. Where Input 2 is fed from high impedance sources it is necessary to insert a shorted plug in Input 1 to short the grid of V.2 to ground.

V.3 and V.4 together may be said to constitute the output stage as the main feedback loop encompasses both. These valves from Input 2, provide a voltage gain for recording of approximately 200. Adding V.2, from Input 1, a gain of 7,000 is available. The load on the output valve during recording is provided through the output transformer by a 15 ohm resistor switched in place of the internal speaker, or when the extension speaker plug is in, by whatever load is there connected. The feedback makes this reasonably non-critical; thus a 15 ohm speaker may be used at this point for monitoring during recording, or headphones shunted with a 15 ohm resistor.

The recording amplifier, as far as the 15 ohm output socket is concerned, has an essentially flat frequency characteristic from 50 to 15,000 c.p.s. The recording head itself is fed from the anode of the output valve through an isolating capacitor and a filter network to provide substantially constant current conditions. A small amount of high frequency pre-emphasis is introduced into this network mainly to compensate for variation of head inductance, and consequently flux, with frequency.

Approximately 20 volts are required for peak modulation at the anode of V.4. The actual value is made to correspond to a reading of '8' on the level meter. The meter is a diode-triode, sustained peak reading, valve-voltmeter with a rapid rise-characteristic on transients and a slow die-away. It has been found to be the only truly satisfactory way of ensuring that the greatest signal-to-noise ratio is maintained consistent with a given maximum value of distortion on peaks, and although costly, is well worthwhile.

To improve the meter characteristics a reversed zero instrument has been used. When in operation the meter is backed off to a steady state current of 1 m.a. by the adjustable "set zero" control in which condition the pointer indicates zero on the scale. The anode at which monitoring takes place is brought out to one pin of auxiliary Socket 1 to facilitate measurements.

## 18.2. The Oscillator

Because of the relatively high frequency response of the "Ferroglyph" for a  $7\frac{1}{2}$ " per second machine, the oscillator frequency itself must be fairly high. It is set to approximately 56 Kc/s. Since it has to serve the erase head as well as supplying the bias, some 2 watts are generated by the self-excited EL84. To prevent the production of undesirable harmonics the grid circuit of this valve is controlled by a Thermistor so that this grid drive is held constant to within very close limits.

A certain amount of feedback is also employed to assist in the generation of as pure a waveform as possible. Even so under certain circumstances individual components of the residual distortion may occasionally beat with the local oscillators of radio sets during recording, if adequate spacing and screening precautions are not taken.

The remedy is of course to ensure that aerial and other leads to the receiver are not taken close to the recorder itself. The output of the oscillator is first taken to the Erase Link at the rear panel for the purpose mentioned in Section 10 of the text.

### 18.3. Design Details—The Mechanical Unit

The mechanical unit is wholly contained on the hinged top deck of the instrument. Three motors are employed. One running counter-clockwise when energized, takes up the tape after having passed through the capstan assembly; the second, running clockwise when energized, rewinds the tape after recording. When partly energized it also maintains a small back tension while recording or playing back. The third motor is employed purely to drive the capstan and fly wheel assembly. It is of synchronous type and is not therefore sensitive to small changes in applied voltage or load once synchronism is established. Its speed, within certain limits, is controlled only by the frequency of the mains supply. In order though that it shall be fed with a reasonably constant voltage irrespective of the supply voltage on which the instrument is being used, it is fed auto fashion from a tapping on the mains transformer. This does ensure that its "drop in" and "drop out" torques remain substantially constant. This motor, running clockwise viewed from its spindle end, carries a two step pulley against either step of which a neoprene rimmed idler wheel drives a heavy fly wheel. Rigidly coupled to this fly wheel is the capstan proper which has a brass bush to which is bonded the loaded neoprene traction surface.

The assembly is mounted on grease-packed angular contact ball races. The speed of the fly wheel at  $7\frac{1}{2}$ " p.s. is approximately 177 r.p.m., the capstan having a diameter of .810".

The head assembly consists of the dual purpose record /reproduce head X5 preceded by the combined erase head /limit switch X4.

This switch is designed to stop the motors and tape drive mechanism at the end of a reel of tape or in the rare event of tape breakage. The presence of tape across the gap in the guide keeps the switch operating arm out of engagement with the contact blades. In the absence of tape, the spring loaded arm is pulled inwards, closing the switch contacts.

The record /reproduce head is mounted on the plate over a small roller so that the head may be rocked over a small angle. This is to enable the gap of the head to be aligned against a standard recorded tape so that all instruments will have the gap at precisely the same angle relative to the tape guides, and so ensure that a recording made on one can be played back on another without loss of the high frequencies which would occur if the recorded track and gap were at different angles.

On the immediate right of the head X5, i.e., following it, is head position 3. This consists of a small cast body, pivoted to permit gap alignment and containing a valve holder into which any Ferrograph record /reproduce head may be plugged and screwed down firmly. For height adjustment between head and tape, shims may be inserted between head and body. To the rear and left of head position 3 will be found the adjusting screw for its gap alignment.

Model 4A is issued with a "dummy" head in the third position, but this can be replaced at any time either with a stereo head type FP14 to convert to model 4S, or a standard head type FR7 for monitor purposes. In the latter case the monitor amplifier should be connected to the "UT" socket on the rear panel and if a head matching transformer is required it should be type 977.

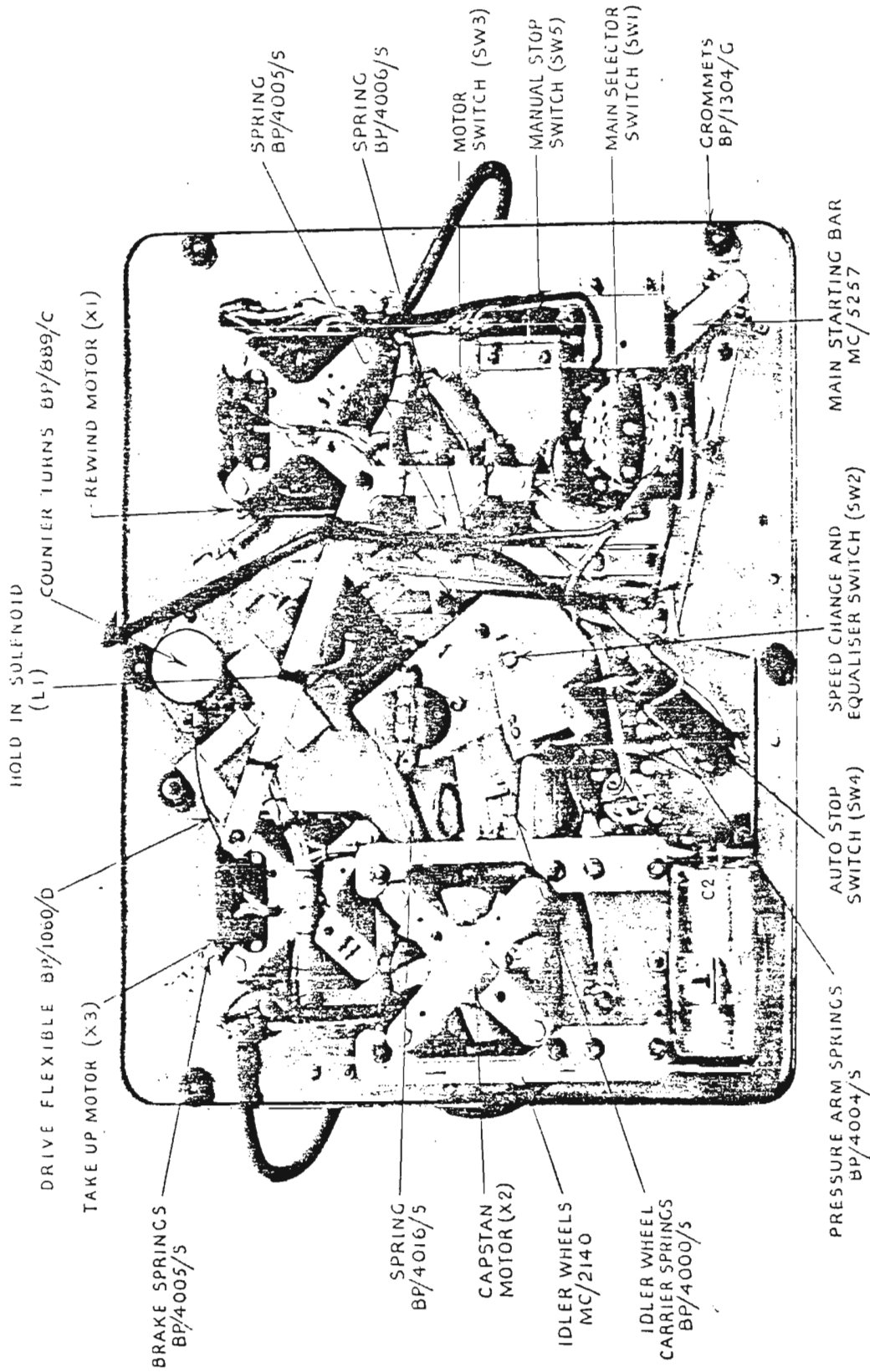

FIG. 17. VIEW OF UNDERSIDE OF DECK

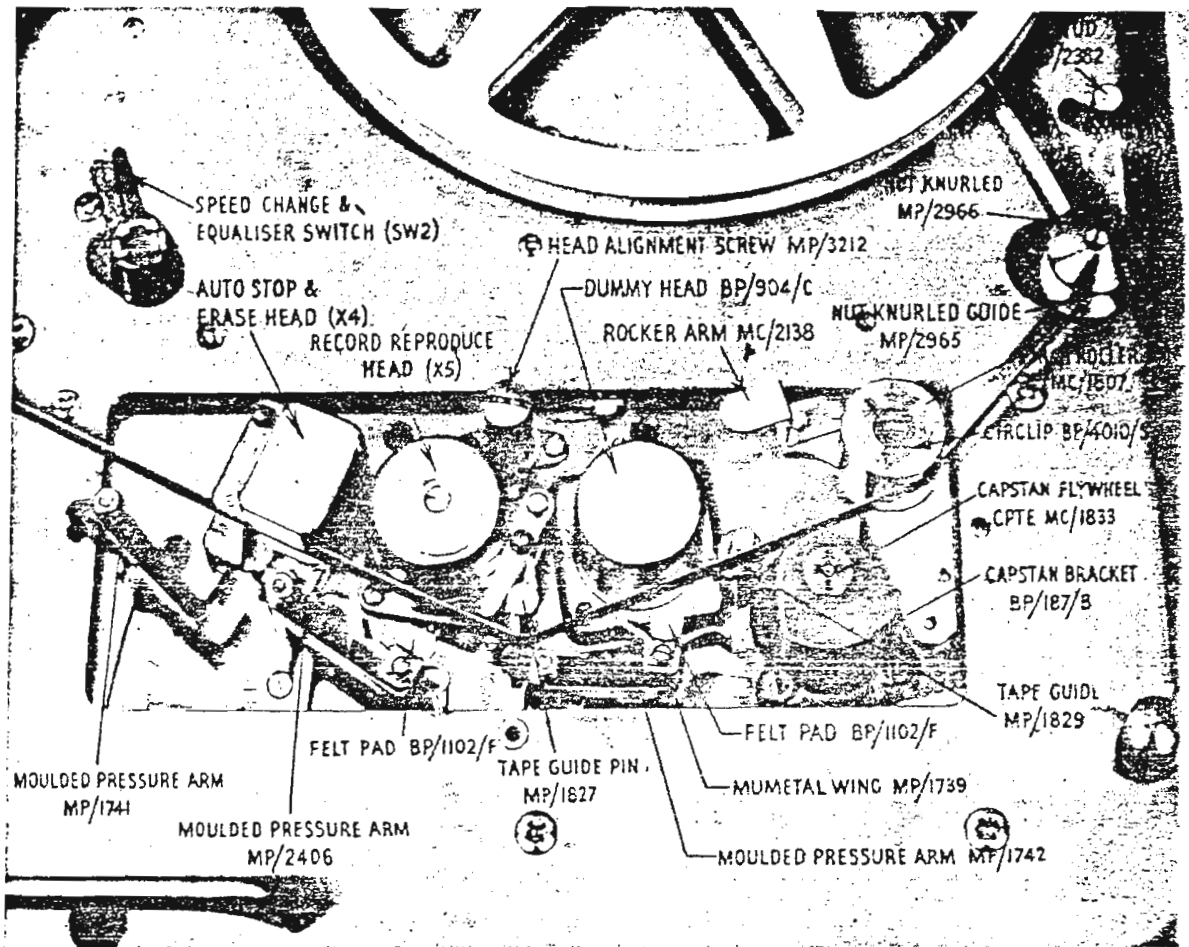

FIG. 18. HEAD AND CAPSTAN ASSEMBLY

The manner in which the tracks are disposed on the tape is shown in Fig. 5. It will be observed that the erasing track is some .025" wider overall than the signal track so as to provide for complete erasure, and the heads are aligned on the plate so that the spreading is substantially equal on either side of the signal track.

Starting and stopping of tape transit is accomplished through the main operating bar (X6) the knob of which protrudes through the small panel at the lower left of the deck. Pulling this arm diagonally towards the front of the equipment operates the main motor switch (SW3) across which is capacitor (C1) for interference suppression, and at the same time pulls the brakes off the reel brake drums. This arm is held in the "on" position by the hold-in solenoid (L1), which is energized from the H.T. feed to the amplifier. To stop the machine this solenoid is shorted by the push switch (SW5) or by the contacts of the auto stop switch previously referred to, which allows the arm to return under its spring tension. This switches off the motors and applies the brakes to the reel drums. These brakes are so arranged as to have self-wrapping properties, that is to say they have their maximum effect on the reel which is being pulled and very little on that which is energized. During rewind therefore a much greater braking tension is applied to the take-up reel so that spillage of tape is avoided, and similarly during "wind on" and normal running, to the magazine reel.

The main operating arm is also linked with the capstan pressure roller and the neoprene rimmed idler wheel of the motor drive, so that these are only brought into engagement with their respective rotating parts when the mechanism is "on". This has been done to provide an instantaneous start and stop of tape transit, and also to prevent the temporary appearance of indentations in the rubber parts, which may be caused if these members are left in engagement under spring tension for prolonged periods. On switching off, these members are knocked out of engagement.

On 4AH instruments (15/7½" per sec.) a flywheel brake is fitted. A tension spring holds the brake shoe against the flywheel rim in the "off" position, and this is pulled off by a linkage with the rocker arm actuating bar when starting. The latter also carries a padded spring to stop the capstan motor quickly.

The change of connections of the heads and motors necessary during the various operations is carried out by the ceramic wafer switch (SW1). One wafer of this looks after the motor feeds and H.T. supply to the oscillator, while the lower controls the switching of the head from the record to the reproduce function. Linked to this switch by a cam arrangement is the lever which deflects the pressure pads from the heads, and the capstan pressure roller even further from the capstan during fast rewind or wind on. It is when these members are so deflected that tape loading is possible.

All the connections from the deck other than the head feed are taken down through a pair of cables ending in octal plugs and sockets to engage with similar plugs and sockets on the amplifier.

#### **18.4. The Playback Amplifier**

Essentially the same amplifier is used for playing-back as for recording, except that V.1 is brought into circuit. Between this valve and the head is a special 1-6 matching transformer. After it, is the frequency correcting network. Because the recording characteristic is on a constant current basis the induced voltage on the head during playback rises at the rate of 6 db per octave up to the point at which self-demagnetization of the tape sets in. The rate at which it falls away thereafter is determined by the tape coating itself. A reverse characteristic obviously has to be included in the playback circuit to produce a flat overall response. This is the function of the network between V.1 and V.2. On a descending basis of course the unequalised response is falling away at the rate of 6 db per octave from the mid-frequency position, and this causes hum to set a limit to the low frequency response possible for a given value of signal to total unweighted noise ratio. The reason for the extensive hum reducing precautions in the deck and amplifier will therefore be appreciated. As has already been described in the text, variable elements have been introduced into the correcting network to provide a certain amount of tone control. Attenuation of both bass and treble is provided, consequently a level response is secured with full clockwise rotation of both controls.

During playback the full negative feedback is maintained on the output valve, consequently distortion is low up to about 2½ watts across the 15 ohm supply and good output regulation and speaker damping are secured. Over 2½ watts, distortion naturally increases very rapidly.

## 19. TESTING AND ALIGNMENT

Where a major component has been replaced it may be necessary to carry out certain re-alignment of the amplifier network. This section is consequently included for the benefit of the Service Engineer. It details the whole testing and setting procedure. It cannot be too strongly emphasised however that indiscriminate re-adjustments should not be made against these instructions without cause, as prior to leaving the factory the "Ferrographs" will have been carefully set up with a great deal of specialized equipment. The fact that there may be slight discrepancies between the reading obtained and those shown below does not mean that adjustments are necessarily called for.

### 19.1. Voltages

Measured with a Model 8 Avometer (20,000 ohms per volt) the following readings should be obtained:—

			<i>On 'Playback'</i>	<i>On 'Record'</i>
Voltage between chassis and input to smoothing choke L4	...	...	= 290	260
Voltage between chassis and output from smoothing choke L4	...	...	= 278	240
Voltage between chassis and input to deck solenoid L1	...	...	= 278	240
Voltage between chassis and output to deck solenoid L1	...	...	= 263	227
Voltage between chassis and junction of R28 /R29	...	...	=	215
Voltage between chassis and junction of R27 /R28	...	...	=	168
Voltage between chassis and junction of R7 /R27	...	...	=	120

Valve heater voltage (incl. rectifier heater) =  $6.3 \pm 0.2V$

**AC Voltages** (245V or 110V, 50 cycles applied)

**Measured on the relevant AC range of an Avometer model "8"**

(1,000 ohms /v)

Playback or Record	245V Model	110V Model
Voltage across capstan motor capacitor	... 400V	220V
Voltage across capstan motor input socket	... 205V on 4A 245V on 4AH	117V
Voltage across take up motor input socket	... 150V	80V
Voltage across rewind motor input socket	... 100V	47V



## VOLTAGES ASSOCIATED WITH VALVES

### On Playback

<i>Valve No.</i>	<i>Anode Voltage</i>	<i>Screen Grid Voltage</i>	<i>Cathode Voltage</i>
V1	40	68	1.5
V2	55	95	2.0
V3	60	125	2.5
V4	242	263	9.5
	<i>On Record</i>		
V5	a' — 240	—	k' — 2.0
V6	240	230	8.0

#### Measured with a valve voltmeter.

53-58 kc/s bias volts between Tags 3 and 1 on deck = 6.5V — 12.0V RMS. Correct value for actual head indicated on deck under flywheel.

Erase voltage between deck tags 1 and 2 between 32 and 40V RMS.

Oscillator Grid drive (across thermistor TH1) = 8.0 — 9.5V.

**Note.** Voltage values are approximate only, especially those connected with V1, V2 and V3 where the tolerances on large value resistors and valves themselves may lead to certain variations.

### 19.2. Gain

The gain should be checked at 400 cycles for the overall measurement including the head lift transformer. Some form of attenuator with a low output impedance will be necessary, *i.e.* less than 10 ohms.

The test should be made with the bass, treble and volume controls fully clockwise and the output voltage should in all cases be measured across Pins 3 and 7 of auxiliary socket 1, *i.e.* at the anode of the output valve.

The following figures should be obtained :—

#### A. Overall Gain

Injecting .5 m.v. across primary of TR1—a voltage gain of 230,000-300,000

#### B. Input 1 Stage Gain

Injecting 10 m.v. into JK1—a voltage amplification of 7,500-8,500.

#### C. Input 2 Stage Gain

Injecting 400 m.v. into JK2—a voltage amplification of 200-230.

When testing the stage gains of Input 1 and Input 2 it is convenient to check the frequency responses of these stages. They should be linear from 60 cycles to 12 K/cycles within  $\pm \frac{1}{2}$  d.B.

### 19.3. Equalisation

If a fault is suspected in the equalisation network it may be statically checked according to the table below to ensure that each element is functioning properly over the frequency band it controls. No attempt though should be made to carry out this check unless all the equipment necessary for the re-setting of the instrument in accordance with 19.6.4 is at hand. The circuits will have been carefully adjusted at the factory having regard to the fact that different heads will require slightly different treatment in order to obtain a linear response, but in the test it will be necessary to destroy this adjustment.

Using the audio generator with the low impedance attenuator, inject across the primary of TR1 .5 m.v. at 400 cycles. Adjust the volume control (leaving the bass and treble controls fully clockwise) until a reading of 25v is obtained across Pins 3 and 7 of auxiliary socket 1, on an A.C. meter with a linear frequency response. With the deck speed control set to 7.5" p.s. voltages as shown in the table should be obtained at other frequencies.

FREQUENCY	OUTPUT METER READING VOLTS	REMARKS
60 cycles	Not less than 125	Set by volume control. Set by R4 (Figs. 16 and 20). Will depend on value of C8 (Figs. 16 and 20).
400 cycles	25	
2000 cycles	8	
6000 cycles	4.0—8.0	
10,000 cycles	Not less than 15	Ensure that R6 is fully in.
14 Kc/s $\pm$ 1 Kc	Not less than 32	This reading to be taken at the frequency where the output "peaks".

The frequency response of the amplifier as set for 3.75" p.s. may vary considerably from instrument to instrument, but if the 400 cycle level is set at 25v, the 60 cycle level should be approximately the same for the 7.5" p.s. equalisation. The 2000 cycle output will depend largely upon the value of R5 (Figs. 16 and 20) and the resonant peak should lie between 4 and 5 Kc/s and give an output greater than 40v.

### 19.4. Bias Trap

The purposes of Coil L3 is to form with C22 a parallel resonant filter at the bias frequency. This is inserted in the feed to the head during recording and by its high impedance prevents the appearance of bias volts, in a reverse direction through the head, at the anode of the signal output valve. By so doing, it also prevents the anode circuit of this valve loading the oscillator bias circuit through the transformer action of the head.

The proper adjustment of the inductance of L3 by its iron core is a compromise between adequate bias voltage at the head winding and a low 53 Kc voltage at the anode of V4. Complete cancellation of the H.F. appearing at this anode point is not necessarily the condition for proper performance. In general though there should be not more than 0.5v of H.F. at this point and it should be possible to adjust the bias volts at the bias winding of the head by the appropriate resistor up to 15v.

### 19.5. Head Alignment

As the recorder leaves the factory its recording head will have been aligned so that its gap is accurately perpendicular to the plane of tape travel. This is carried out against a master tape kept for the purpose. It is important insofar as it controls the degree to which interchangeability of recordings between different machines is possible without loss of high frequency response. For this reason the recording head should not be interfered with. In practice it is the component least likely to give trouble.

In cases where the derangement of its setting has been unavoidable its re-alignment will require a test tape carrying a standard signal of high frequency. This is played back and the head is adjusted on the .050" roller on which it seats by the 4 fixing screws until a maximum output position is obtained. As the head gap is rocked from one side of the perpendicular to the other, the high frequency output may pass through successive maxima but it is of course the greatest of these which represents the position to be finally adopted.

### 19.6. Checking the Entire Instrument

The complete alignment of the recorder and the measurement of its performance requires a great deal of test equipment. Much of this will not be in the hands of the normal Service Engineer. In the following description, alternative methods of measuring the various factors involved are given but it must be pointed out that in some cases these will be little more than estimates, particularly in respect of distortion and "wow".

#### 19.6.1. Recording Level

It is assumed that the tests of gain, etc., previously detailed have been carried out. The next step is the checking of the recording level. By this is meant the maximum signal which can be applied to the head network for a given amount of distortion on playback. As the instruments leave the works this level will be set so as to produce not more than 5% total distortion on peaks. The process is as follows:—

With the main selector switch turned to "record" and the gain control at zero, check that the bias voltage agrees with the stated value, which for the particular deck is to be found on the small label on the plate under the flywheel. The bias can be measured between Deck Tags 3 and 1 with a valve-voltmeter.

Adjust the recording level meter accurately to zero and inject a source of 400 cycles into Input 1 at a level of approximately 10 m.v. Connect an A.C. voltmeter and a wave analyser or distortion meter between Pins 3 and 7 on auxiliary socket 1. Then adjust the gain control until the recording level meter reads 8. Check that the reading on the A.C. voltmeter is between approximately 18 and 25v.

Re-adjust the gain control until the level meter reads 6 and then record a short length of tape at this level at 7.5" p.s. Stop the tape, making a suitable reference signal or mark and then proceed to record another passage with the signal level meter reading 7. Repeat the procedure at readings of 8 and 9.

Rewind to the start of the test signals and then playback into the wave analyser or distortion meter. Measure the distortion obtained for each signal input level and note that which produces the 5% referred to. This reading is then the proper peak signal level.

This particular test signal may usefully be replayed with the gain control turned fully clockwise so as to check that the playback level off the tape is sufficient fully to load the amplifier. This will be shown by a reading on the A.C. meter of at least 135v above which serious distortion should ensue.

Where a distortion meter is not available some idea of the total distortion can be obtained by applying the output from Pins 3 and 7 to the Y plates of an oscilloscope at the same time connecting the X plates direct to the output of the audio oscillator. Because of phase differences an ellipse can be obtained on the screen of the cathode ray tube and the regularity of this ellipse can be used to give an indication of the distortion present. Some experience is normally necessary to relate 5% distortion to the modified shape of the ellipse, so that it is not possible easily to give definite guidance.

Should it be found that a meter reading greater than 8 is necessary before the 5% distortion point appears, the values of R23 and R22 may be adjusted so as to produce a lower meter reading for a given applied voltage.

### **19.6.2. Bias Checking**

If a recording head has been replaced or if after very long use it is suspected that the head requires a different value of bias, a test for optimum bias may be instituted as follows :—

Record a 200 cycle note at a level of approximately 3 on the meter with values of bias voltage (as measured across Tags 3 and 1 on the deck with a valve-voltmeter and obtained by adjusting R38) of 6, 8, 10, 12 and 14v. Play back these test recordings with all controls at their clockwise maximum and note the output voltage across Pins 3 and 7 on auxiliary socket 1 corresponding to each different bias setting.

It will be found that the output voltage will rise with increasing bias to a given point and will then slowly fall off. The correct bias setting to use is a voltage slightly in excess of that which gives the maximum signal output.

### 19.6.3. "Wow" and "Flutter"

The only reliable method of checking "wow" and "flutter" is by instruments specially designed for the purpose. These fall broadly into two categories, one where the "wow" and "flutter" components are read together or separately on meters as an R.M.S. "wow" and "flutter" factor, and the other whereby the frequency modulation component on the recorded carrier is fed after discrimination to a high speed pen recorder which indicates both the peak "wow" and "flutter" factor and its nature and frequency.

Both these systems are used in the initial factory setting of the machines. It is unlikely however that either will be in the possession of the normal Service Engineer so that here again it is necessary to use systems which allow some estimation.

One of the best of these uses an oscilloscope substantially as described above for the distortion measurements but here instead of observing the shape of the ellipse it is necessary to observe the rate and the degree to which the axis of the ellipse changes, thereby indicating the instantaneous phase differences between the stable signal from the audio oscillator and the fluctuating signal from the tape during playback. Some "wow" and "flutter" is of course inevitable, it is therefore once again a matter of estimating the degree.

### 19.6.4. Frequency Response

There are 6 variables concerned with the playback equalisation and they are to be found on the equaliser panel. (Fig. 20 in dotted outline and Fig. 16 at the end of the amplifier.) C7, R5, C8 and C6 may be changed by unplugging from their sockets, and R4 and R6 are continuously variable.

The treble boost inductor L2 can also be removed from its socket by loosening the small clamp at its base. Each of these components affects a specific part of the audio frequency band as follows:—

C7 is the bass lift capacitor and controls mainly the bass response at both speeds.

R4 is most effective in the range around 2000 cycles at 7.5" p.s.

R5 is most effective in a similar band at 3.75" p.s.

C8 controls that part of the spectrum from approximately 4000 to 10,000 c.p.s. at 7.5" p.s.

C6 is used to resonate L2 on 7.5" p.s. only and has a vital effect on the highest audio frequencies in the range 9000 to 12,000 cycles.

R6 connected with C6 and L2 controls the amount of this high frequency lift.

To adjust or check the frequency response of 7.5" p.s. a frequency sweep from 40 to 13,000 cycles at a reading of approximately 2 on the level meter should be recorded. In the absence of a synchronous continuous sweep it will probably be necessary to carry this out in short independent steps carefully noting the frequency at each point. (The low recording level is necessary to avoid overloading the tape at the higher frequencies due to pre-emphasis.)

If now an A.C. meter or a valve-voltmeter having a level response over the band in question is connected across a 15 ohm resistor plugged into Jack 3, the frequency sweep may be played back and the various output levels noted. R4 should be adjusted so that the valve-voltmeter shows the same output at 2,000 cycles as at 400. Then R6 should be adjusted to keep the response level at the highest frequencies. If there is a peak or dip for the curve around 6 to 9 Kc/s this may be taken out by making C8 larger or smaller in value. At 3.75" p.s. the same procedure should be followed except that the frequency range will necessarily be more restricted (40 to 6,000 cycles). R5 will be found to affect frequencies between 1,000 and 2,000 cycles. The resonant point at the upper end may be advanced or withdrawn by altering C3 on the speed change switch panel.

#### 19.6.5. Hum Level

If any major work has been carried out upon the amplifier or deck, the hum level may be affected. The main factors controlling this are :—

- A. The first valve of the replay chain.
- B. The position of TR3.
- C. The adjustment of the Mumetal wing on the playback head pressure arm.

Secondary factors affecting the hum may be :—

- D. The second valve (this is the first valve of the recording chain and may cause hum to be recorded).
- E. The position of L2.
- F. The position of the microphone matching transformer (if one is used).
- G. The polarity of the mains input.

The presence of hum is most easily detected by a sensitive meter, or a cathode ray tube with an amplifier, connected across Pins 3 and 7 of auxiliary socket 1. It can be controlled in some measure by the position of the mains transformer TR3 which is arranged so that it can be rotated for minimum hum pick-up on the sensitive components. Any adjustment to it should be made while the motors on the deck are running as this of course is the proper condition of playback.

Care should be taken to see that there is not too great a difference between the readings with the motors running and with the motors stopped, as this will indicate that hum bucking is taking place, *i.e.* that some hum is being injected in anti-phase

to that arising from some other part of the equipment. The object should be to align everything for minimum pick-up. With full amplifier gain the hum voltage should not exceed  $\cdot 75\text{v}$  R.M.S. with motors both running and stopped.

A useful method of obtaining a final minimum figure is by varying the angle the mumetal wing on the playback head pressure pad arm makes with the tape. The only precaution necessary in adjusting this is to ensure that the pressure pad contact area is not adversely affected.

Although only a secondary factor the position of L2 can be altered in certain fixed steps by extracting it and re-plugging it into its valve-holder in a different position, the holder being so wired that this may be done.

The polarity of the mains connection can also usefully be checked as this sometimes effects a desirable reduction.

#### **19.6.6. Signal to Noise Ratio**

The unweighted signal to noise ratio quoted in the specification is the ratio of the R.M.S. noise from the erased tape plus the hum content compared with the R.M.S. signal output from a fully recorded tape playing back at 5% distortion. This means that the gain control must not be turned fully clockwise as this will obviously overload the amplifier.

## **20. ALTERNATIVE 4A MODELS**

Model 4AH is substantially similar to Model 4A but has speeds of  $7\frac{1}{2}$ " and 15" p.s. This higher speed naturally gives an improved performance but of course gives only one half of the playing time. The circuit changes necessitated by this higher speed are given in the main circuit diagram.

Model 4AL has speeds of  $1\frac{1}{2}$ " and  $3\frac{1}{2}$ " p.s. and is designed for those applications where the longest playing time is necessary, and speech or similar signals only have to be handled. The main diagram shows the circuit changes necessary for this speed.

110 volt versions of all types are manufactured and also models for operation on 60 cycle supplies.

## **21. CONVERSION OF 4A TO 4S**

All that is necessary to convert a model 4A to a 4S is to unscrew the "dummy" in head position 3 and replace it by a stereo head type F.P.14. This is supplied with shims which must be inserted between the head and the holder to align the head correctly with the tape.

It should be checked after fitting, to ensure that the top edge of the tape is level with, or only just above, the top edge of the laminations. The latter are a bright silver colour against the brass spacing pieces.

The stereo head will then require its gap aligning at right angles to the tape by adjustment of the rear screw as outlined in the 4S instructions "PLAYING BACK PRE-RECORDED TAPES".

“FERROGRAPH”  
MODEL 4S



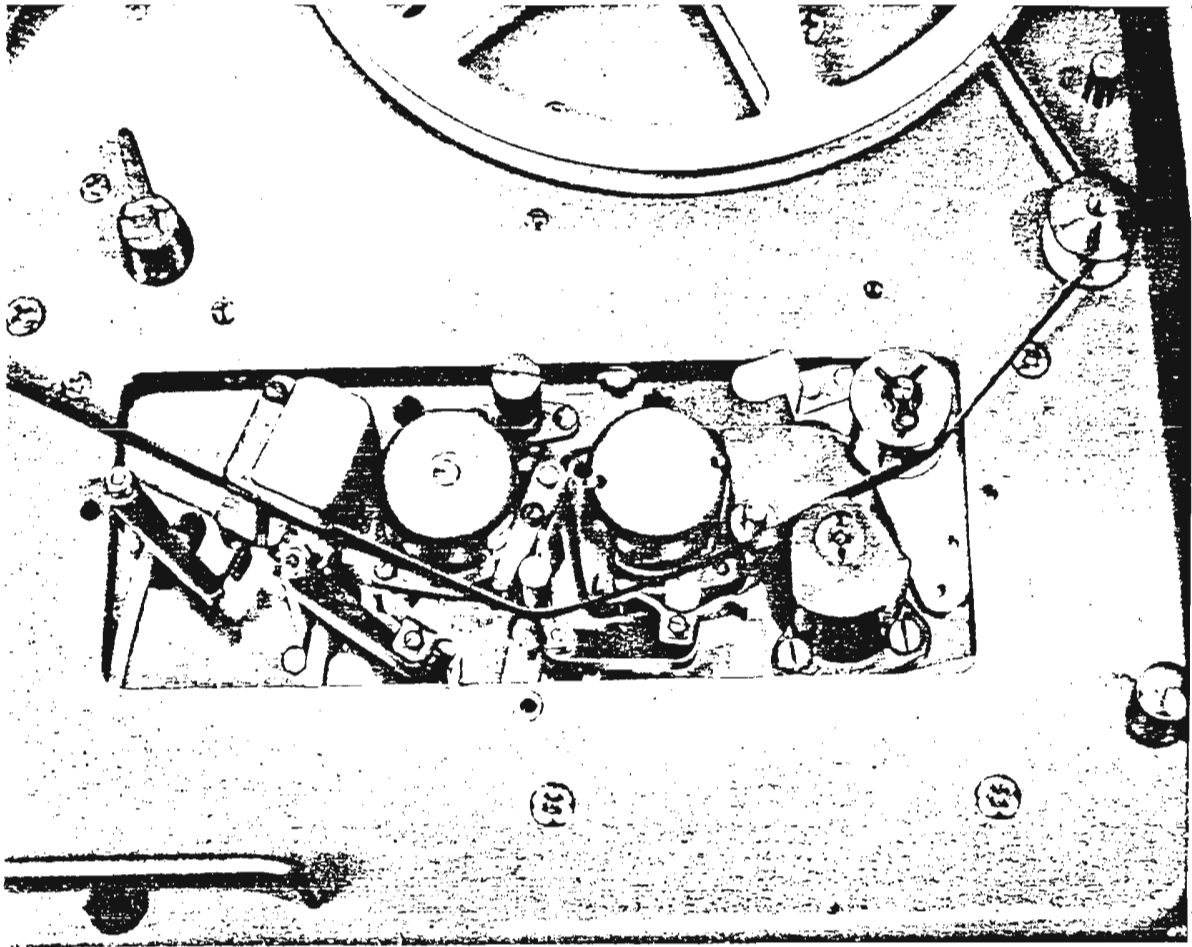

FIG. 19. MODEL 45. SHOWING STEREO HEAD IN POSITION

For Service Manuals Contact  
MAURITRON TECHNICAL SERVICES  
8 Cherry Tree Rd, Chinnor  
Oxon OX9 4QY  
Tel:- 01844-351694 Fax:- 01844-352554  
Email:- [enquiries@mauritron.co.uk](mailto:enquiries@mauritron.co.uk)

## FERROGRAPH MODEL 4S

### GENERAL DESCRIPTION

This model is very similar to the model 4A, the only difference being that a stereo playback head type F.P.14 is fitted in "head position 3" instead of the dummy head. The connections from this are taken directly to two sockets marked STEREO OUTPUT UT and LT, (upper and lower tracks respectively) on a small panel at the rear of the cabinet.

By connecting a Ferrograph "Stere-ad" Unit, or other suitable amplifiers to these sockets, stereo pre-recorded tapes can be played back.

### CONNECTION OF EXTERNAL AMPLIFIERS TO STEREO OUTPUT SOCKETS

#### 1. Output available

As the connection to both UT and LT sockets is straight from the stereo head windings, the signal obtained will be unequalised and compensation will be required in the external amplifier.

As the stereo head windings are low impedance, approx 40 ohms at 1000 cycles, it is recommended that head matching transformers type 979 be used. These are small, astatically wound for minimum hum pick-up, and completely screened in a mumetal can. When used between head and amplifier input, they will give a useful voltage step up of roughly 36 times resulting in an available peak voltage at 1000 cycles of approx. 18 mV at the secondary, from a tape recorded to that level giving a distortion of between 3 and 5% on playback. Without a transformer, under the same conditions, the voltage available is 0.5 mV.

#### 2. Equalisation

Due to manufacturing tolerances it is difficult to specify a fixed equalisation circuit. It is therefore recommended that if an absolutely flat frequency response is required, a test tape is used and the equalisation set up with the aid of a suitable output meter. On a pre-recorded tape to the C.C.I.R. characteristic it should be easily possible to obtain a response of  $\pm 3$  dB between 60 and 10,000 cycles at  $7\frac{1}{2}$ " per sec.

### CONNECTIONS

In the absence of a "Stere-ad" unit, which is dealt with in its own instruction booklet, the following is intended as a general guide

The plug for the "stereo" sockets on the rear panel is PAINTON and Co's type P2/CT 313260 or Ferrograph type BP/2330/P.

The Ferrograph and the external amplifiers should have a common mains "earth" connection to avoid the possibility of hum due to "earth loops", and also when positioning the various units, the power supply section on the external amplifier should be kept away from the immediate vicinity of the Ferrograph, especially from the bottom left hand corner. In addition, some adjustment of the stereo output sockets on the rear panel may be necessary to obtain the lowest possible hum from the combination. This procedure may be carried out as follows :—

First slacken off the four screws spaced round the sockets, then with everything set up in an operating condition, slowly rotate each socket and plug for a minimum hum position on each track. Care should be taken not to rotate the sockets more than the full circle to avoid damage to the leads connected at the back. A further measure with regard to hum which might usefully be done at the same time would be to slightly loosen the screw in the stereo head pressure arm securing the mumetal "wing", so that the latter can be inclined (in a horizontal plane) over a small arc relative to the head. This operation will be found to have some effect on the residual hum, and, combined with the socket rotation, will enable the lowest possible hum level to be obtained. Before tightening the mumetal wing in its final position, check that the pressure pad is still acting over the full width of the tape and ensuring intimate contact of the latter against the head, also that the 'wing' has not been inclined so much that it contacts the head can.

### **PLAYING BACK PRE-RECORDED STEREO TAPES**

It is recommended that, before commencing to play pre-recorded stereo tapes, the "erase link" plug be removed from the rear panel socket. This will completely disconnect the oscillator supply from the tape deck and so prevent any possibility of erasure or recording of "clicks", due to accidentally tuning to the "record" position. If the Ferrograph "Stere-ad" unit is being used this feature is taken care of automatically by the plug in auxiliary socket 2. If no specific instructions are given with the pre-recorded tape, the usual convention is to have the two loudspeakers spaced 7—10 feet apart with the upper track speaker on the left.

The gain control of the Ferrograph should be turned to zero to prevent an additional upper track playback through the standard head and internal speaker.

As the model 4S leaves the factory, the stereo head gap will be aligned exactly at right angles to the tape, but if for any reason there is a deficiency in the upper register, the adjusting screw (see section 18.3) can be tuned for maximum treble response. It is sometimes easier to align on background hiss with the ear close to the loudspeaker.

The external amplifiers will presumably have either separate gain controls or some form of balance control to adjust each track for the same output level.

### **'MONITOR' APPLICATION**

The following remarks apply only when a completely external amplifier is connected to the "UT" rear socket, i.e. not when the Stere-ad unit is used, as then recording is not possible.

During monaural recording, the upper track of the stereo head can also be used for monitoring the signal off the tape provided it is recognised that the "cross talk" between tracks in the stereo head is of the order of 40dB, so that a faint signal from the lower track (if this is recorded) might be heard when monitoring.

### **Alternative model**

The 4S may also be obtained in the  $15/7\frac{1}{2}$  ins/sec version when it is designated model 4SH.

“FERROGRAPH”  
MODEL 4A/CON

For Service Manuals Contact  
**MAURITRON TECHNICAL SERVICES**  
8 Cherry Tree Rd, Chinnor  
Oxon OX9 4QY  
**Tel:- 01844-351694 Fax:- 01844-352554**  
**Email:- enquiries@mauritron.co.uk**

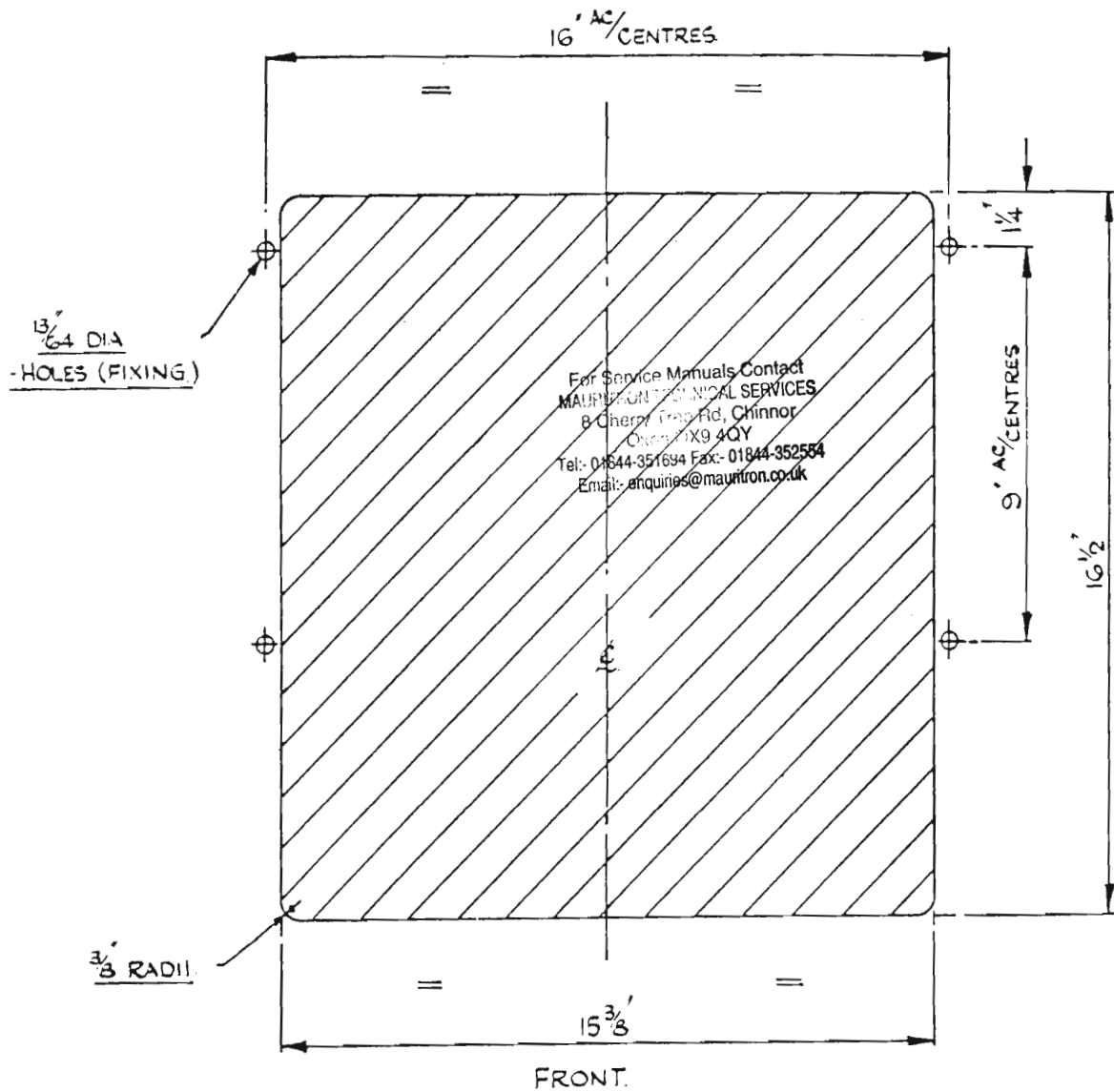

PANEL DRILLING & CUT OUT DETAILS  
FOR MOUNTING SERIES 4 CON. FERROGRAPHS.

FIG. 21.

For Service Manuals Contact  
 MAURITRON TECHNICAL SERVICES  
 8 Cherry Tree Rd, Chinnor  
 Oxon OX9 4QY  
 Tel: 01844-351694 Fax: 01844-352554  
 Email: enquiries@maurtron.co.uk

## **THE "FERROGRAPH" MODEL 4A /CON.**

The model 4A /CON is another version of the standard 4A adapted for use in a permanent installation.

It is supplied as a complete unit but without cabinet or loudspeaker and can be readily built into a piece of furniture or an existing cabinet.

The method of installation is to cut a hole of the dimensions shown in Fig. 21, in the mounting tray or surface and then lower the model 4A /CON into it. 4 bolts then fix the whole assembly rigidly to the mounting board as indicated.

A 15 ohm loudspeaker should be plugged into the same socket used for the internal speaker on the standard model 4A.

In all respects, the same operating instructions, circuit, etc., apply as the model 4A.

## **ALTERNATIVE MODELS**

The 4A /CON may also be obtained in the  $15/7\frac{1}{2}$  ins /sec version, when it is designated model 4AH /CON.

Similarly there are models 4S /CON and 4SH /CON.

**APPENDIX A**  
**OPERATIONAL FAULT ANALYSIS**

FAULT	POSSIBLE OPERATIONAL CAUSE
1. Machine will not start; indicator lamp does not light up.	Fuse blown (see Fig. 1). Mains lead or plug faulty. Selector knob loose or missing.
2. Motor starts, but starting switch will not lock in, amplifier having had time to warm up.	Tape not properly positioned in head box. (See Page 6).
3. Start switch only just holds in, or releases during playing.	Low mains voltage. Check position of selector knob and actual mains voltage.
4. Tape slips in drive or "wows"	Dirty capstan or accumulation of tape deposit on pressure roller. Bad splice in tape sticking in guides or heads. Buckled reels scraping on deck. Dirt in gate mechanism preventing proper closure. Oversize tape. Oil or Grease on idler wheel rim.
5. Known, well recorded tape will not play back but tape drives.	Input plug left in. Unconnected output speaker plug left in. Tape incorrectly positioned in head box. Piece of splicing tape sticking over head working face. Gain control at zero.
6. Tape plays back with poor frequency response.	Accumulation of foreign matter or tape coating over head gap.
7. In recording position tape erases but will not record.	Microphone or input plug not properly inserted, or in wrong socket. Microphone cable faulty. No input signal.

**For Service Manuals Contact**  
**MAURITRON TECHNICAL SERVICES**  
8 Cherry Tree Rd, Chinnor  
Oxon OX9 4QY  
Tel:- 01844-351694 Fax:- 01844-352554  
Email:- enquiries@mauritron.co.uk

Appendix A : *continued*

FAULT	POSSIBLE OPERATIONAL CAUSE
8. Records, but incompletely erases previous recording.	Heads incorrectly aligned with tape, i.e., lower track is heard. Dirt over erase head gap or splicing material stuck to working face.
9. Records weakly and with very poor frequency response.	Tape coating outside instead of inside. No bias voltage at record head.
10. Low pitched hum during playback (tape stationary).	Instrument being operated over power cables or near equipment with high external fields, i.e., saturable reactors.
11. Hum recorded on tape. (Check by changing speed. If hum is recorded, its frequency will be halved).	Microphone in hum field. Microphone transformers or leads insufficiently screened. Microphone leads or stand indifferently earthed, or in contact with mains leakage paths.
12. Tape runs at one speed but not at the other.	Idler carrier spring (Fig. 17) broken. Idler wheel circlip missing and wheel has "run off".
13. Tape slows up or stops on Wind back or Wind on.	Reel motor bearings out of alignment making spindle tight—Push drum adaptor sideways from various directions until it can be spun freely on both motors.
14. Automatic switch does not work at end of reel.	Actuating arm not fully entering slot. Operating spring overstretched (some stretching is normal). Forked arm bend requires adjustment.
15. Take-up drum adaptor appears to run hot especially compared to wind back motor	It is normal for the take-up drum adaptor to feel hot to the touch, because the wind back motor runs at a lower voltage, the effect is less with it.
16. Hands on counter dial remain stationary.	Drive cable broken. Fit new cable. When fitting do not push ends too far down spindles so that cable assumes a 'flattened' curve.



APPENDIX B

COMPREHENSIVE LIST OF COMPONENTS FOR ALL SERIES 4 FERROGRAPHS  
INCLUDING NARTB VERSION IN APPENDIX C

CIRCUIT REF.	VALUE	RATING	DESCRIPTION	W. AND W. PART NOS.
R1	1.2K $\Omega$	27w	Wire-wound	BP/2819/R
R2	100K $\Omega$	$\frac{1}{2}$ w	Carbon	BP/2851/R
R3	4.7K $\Omega$	$\frac{1}{2}$ w	Carbon	BP/2831/R
R4	5K $\Omega$		Wire-wound Potentiometer	BP/2428/P
R5	* 6.8K $\Omega$	$\frac{1}{2}$ w	Carbon	
R6	25K $\Omega$		Carbon Potentiometer	BP/2402/P
R7	270K $\Omega$	$\frac{1}{2}$ w	Carbon	BP/2855/R
R8	100K $\Omega$	$\frac{1}{2}$ w	High Stability	BP/2850/R
R9	1.5K $\Omega$	$\frac{1}{2}$ w	High Stability	BP/2823/R
R10	500K $\Omega$		Carbon Pot. (Bass Control)	BP/2411/P
R11	500K $\Omega$		Carbon Pot. (Treble Control)	BP/2411/P
R12	270K $\Omega$	$\frac{1}{2}$ w	Carbon	BP/2855/R
R13	1M $\Omega$	$\frac{1}{2}$ w	Carbon	BP/2863/R
R14	100K $\Omega$	$\frac{1}{2}$ w	High Stability	BP/2850/R
R15	1.5K $\Omega$	$\frac{1}{2}$ w	High Stability	BP/2823/R
R16	500K $\Omega$		Carbon Pot. (Gain Control)	BP/2411/P
R17	270K $\Omega$	$\frac{1}{2}$ w	Carbon	BP/2855/R
R18	100K $\Omega$	$\frac{1}{2}$ w	Carbon	BP/2852/R
R19	1.5K $\Omega$	$\frac{1}{2}$ w	High Stability	BP/2823/R
R20	470K $\Omega$	$\frac{1}{2}$ w	Carbon	BP/2861/R
R21	220 $\Omega$	1w	Carbon	BP/2807/R
R22	* 200K $\Omega$	$\frac{1}{2}$ w	Carbon	
R23	2.2M $\Omega$	$\frac{1}{2}$ w	Carbon	BP/2864/R
R24	4.7K $\Omega$	$\frac{1}{2}$ w	Carbon	BP/2831/R
R25	5K $\Omega$		Wire-wound Potentiometer	BP/2433/P
R26	470K $\Omega$	$\frac{1}{2}$ w	Carbon	BP/2861/R
R27	47K $\Omega$	$\frac{1}{2}$ w	Carbon	BP/2849/R
R28	22K $\Omega$	$\frac{1}{2}$ w	Carbon	BP/2843/R
R29	15K $\Omega$	$\frac{1}{2}$ w	Carbon	BP/2842/R
R30	* 13K $\Omega$	$\frac{1}{2}$ w	Carbon	
R31	15 $\Omega$	1w	Carbon	BP/2801/R
R32	22K $\Omega$	$\frac{1}{2}$ w	Carbon	BP/2843/R
R33	150K $\Omega$	$\frac{1}{2}$ w	Carbon	BP/2853/R
R34	15 $\Omega$	$\frac{1}{2}$ w	Carbon not supplied (See Text)	BP/2801/R
R35	* 6.8K $\Omega$	$\frac{1}{2}$ w	Carbon	
R36	220 $\Omega$	1w	Carbon	BP/2807/R
R37	1.5K $\Omega$	$\frac{1}{2}$ w	Carbon	BP/2824/R

Appendix B : continued

CIRCUIT REF.	VALUE	RATING	DESCRIPTION	W. AND W. PART NOS.
R38	5K $\Omega$		Wire-wound Potentiometer	BP /2428 /P
R39	47K $\Omega$	$\frac{1}{2}$ w	Carbon	BP /2849 /R
R40	100K $\Omega$	$\frac{1}{2}$ w	Carbon	BP /2852 /R
R41	33K $\Omega$	$\frac{1}{2}$ w	Carbon	BP /2845 /R
R42	100 $\Omega$	$\frac{1}{2}$ w	Carbon	BP /2852 /R
R43	250 $\Omega$	27w	Wire-wound	BP /2808 /R
R44	5K $\Omega$		Wire-wound Potentiometer	BP /2428 /P
R45	150K $\Omega$	$\frac{1}{2}$ w	Carbon	BP /2879 /R
R46	47K $\Omega$	$\frac{1}{2}$ w	Carbon	BP /2848 /R
R47	150K $\Omega$	$\frac{1}{2}$ w	Carbon	BP /2853 /R
R48	150K $\Omega$	$\frac{1}{2}$ w	Carbon	BP /2853 /R
C1	0.1 mfd.	350v	Metal Tubular	BP /707 /C
C2	.75 mfd.	450v	A.C. Working	BP /715 /C
C3	* 0.02 mfd.	350v	Metal Tubular	
C4	0.1 mfd.	350v	Metal Tubular	BP /708 /C
C5	2,000 pf.		Silver Mica	BP /517 /C
C6	* 2,500 pf.		Silver Mica	
C7	* 0.04 mfd.	500v	Metal Tubular	
C8	* 8,200 pf.		Silver Mica	
C9	16 mfd.	500v	Electrolytic	BP /756 /C
C10	50 mfd.	12v	Electrolytic	BP /763 /C
C11	8 mfd.	500v	Electrolytic	BP /756 /C
C12	16 mfd.	500v	Electrolytic	with C11
C13	8 mfd.	500v	Electrolytic	with C9
C14	0.1 mfd.	350v	Metal Tubular	BP /708 /C
C15	0.05 mfd.	350v	Metal Tubular	BP /706 /C
C16	100 mfd.	25v	Electrolytic	BP /761 /C
C17	25 pf.		Silver Mica	BP /539 /C
C18	0.5 mfd.	500v	Metal Tubular	BP /714 /C
C19	0.5 mfd.	150v	Metalised Paper Tubular	BP /712 /C
C20	0.05 mfd.	350v	Metal Tubular	BP /706 /C
C21	0.1 mfd.	350v	Metal Tubular	BP /708 /C
C22	460 pf.	350v	Silver Mica	BP /553 /C
C23	250 pf.		Silver Mica	BP /541 /C
C24	16 mfd.	500v	Electrolytic	BP /756 /C
C25	0.1 mfd.	350v	Metal Tubular	BP /708 /C
C26	8 mfd.	500v	Electrolytic	with C24
C27	0.1 mfd.	350v	Metal Tubular	BP /708 /C
C28	10,000 pf.		Silver Mica	BP /522 /C

## Appendix B: continued

CIRCUIT REF.	VALUE	RATING	DESCRIPTION	W. AND W. PART NOS.
C29	16 mfd.	500v	Electrolytic	BP/757/C
C30	16 mfd.	500v	Electrolytic	with C29
C31	4,000 pf.		Silver Mica	BP/520/C
C32	0.1 mfd.	350v	Metal Tubular	BP/708/C
C33	2.5 mfd.	300v	A.C. Working	BP/717/C
C34	8 mfd.	100v	Electrolytic	BP/769/C
C35	.25 mfd.	150v	Metal Tubular	BP/710/C
C36	200 pf.		Moulded Mica	BP/547/C
C37	500 pf.		Moulded Mica	BP/538/C
C38	120-360pf.		Ceramic Trimmer	
C39	80-240 pf.		Ceramic Trimmer	with C38
C40	200 pf.		Moulded Mica	BP/547/C
C41	80-240 pf.		Ceramic Trimmer	
C42	30-110 pf.		Ceramic Trimmer	with C41
SW1			Ceramic Switch	DN 1755
SW2			Ceramic Switch	DN 2228
SW3			Motor Switch	DNA1216B
SW4			Auto Switch	DNA1216A
SW5			Manual Switch	DNA1216C
SW6		250v	Toggle Switch	BP/4067/S
SW7			Ceramic Switch	DN2515
L1			Hold-in Solenoid	T 1404
L2	52mH		Treble Boost Inductor	727
L3	20mH		Filter Coil	666
L4	12H		Choke	T 1551
L5			Oscillator Coil	726
L6	1.15H		Pre Emphasis Coil	DNA5145
L7	1.15H		Pre Emphasis Coil	DNA5145
TR1	Ratio 1: 6		Head Input Transformer	977/965
TR2			Output Transformer	T 1428
TR3			Mains Transformer	T 1552B
TR4			Mains Transformer	T 1552A
JK1			2 way Jack	BP/1500/J
JK2			2 way Jack	BP/1500/J
JK3			2 way Jack	BP/1500/J
V1			Valve EF86	BP/7106/V
V2			Valve EF86	BP/7106/V
V3			Valve EF86	BP/7106/V
V4			Valve EL84	BP/7108/V

Appendix B : continued

CIRCUIT REF.	VALUE	RATING	DESCRIPTION	W. AND W. PART NOS.	
V5			Valve ECC83	BP 7130 V	
V6			Valve EL84	BP 7108 V	
V7			Valve EZ80	BP 7109 V	
M1			Meter 0-1 mA D.C. Reverse Reading Grey	BP 1932 M	
LS1			Elliptical Speaker 10" x 6"	BP 4157 S	
X1	For Service Manuals Contact <b>MAURITRON TECHNICAL SERVICES</b> 8 Cherry Tree Rd, Chinnor Oxon OX9 4QY Tel: 01844-351694 Fax: 01844-352554 Email: enquiries@mauritron.co.uk		Rewind Motor	DNA5229/150	
X2			Capstan Motor	DNA5231/240	
X3			Take-up Motor	DNA5230/150	
X4			Erase Head	DNA5175	
X5			Record/Reproduce Head	DNA1217	
X6			Rewind Motor	DNA5229/75	
X7			Capstan Motor	DNA5231/110	
X8			Take-up Motor	DNA5230/75	
LP1			Neon Lamp (Red)	BP 1810/L	
FS1		1A		Fuse	BP 1252/F
FS2		2A		Fuse	BP 1253/F
TH1				Thermistor STC. A1 522/100	BP 5002/T

LIST OF COMPONENTS

FERROGRAPH MODEL 4AH 7½ 15ins/sec. 240v 50cycle.

The component values for this model are exactly as for Model 4A 3¾"/sec. 7½"/sec. with the exception of the equaliser components listed below. For 110v 50cycle version of this model the same listed component variations are applicable.

CIRCUIT REF.	VALUE	RATING	DESCRIPTION	W. AND W. PART NOS.
R5	* 2.2K Ω	½w	Carbon	
R50	* 2.2K Ω	½w	Carbon	
C3	* 0.01 mfd.	350v	Metal Tubular	
C6	* 7,700 pf.		Silver Mica	
C7	* 0.04 mfd.		Metal Tubular	
C8	* 0.03 mfd.		Combination : Silver Mica Metal Tubular	
C50	* 5,700 pf.		Silver Mica	
L2	12 mH		Treble Boost Inductor	728

## LIST OF COMPONENTS

### FERROGRAPH MODEL 4AL $1\frac{7}{8}/3\frac{3}{4}$ ins/sec. 240v 50cycle.

The component values for this model are exactly as for Model 4A  $3\frac{3}{4}$ "/sec.  $7\frac{1}{2}$ "/sec. with the exception of the equaliser components listed below. For 110v 50cycle version of this model the same listed component variations are applicable.

CIRCUIT REF.	VALUE	RATING	DESCRIPTION	W. AND W. PART NOS.	
R4	25K $\Omega$	$\frac{1}{2}$ w	Carbon Potentiometer	BP/2402/P	
R5	* 15K $\Omega$		Carbon		
C3	* 0.03 mfd.		Combination : Silver Mica Metal Tubular		
C6	* 3,100 pf.		Silver Mica		
C7	* 0.04 mfd.		Metal Tubular		
C8	* 2,000 pf.		Silver Mica		
L2	142 mH		Treble Boost Inductor		729

On 110v 50cycle versions, component changes in Main List are :—

CIRCUIT REF.	VALUE	RATING	DESCRIPTION	W. AND W. PART NOS.
R1	250 $\Omega$	270w	Wire-wound	BP/2808/R
C2	3 mfd.	300v	A.C. Working	BP/718/C
X1			Rewind Motor	DNA5229/75
X2			Capstan Motor	DNA5231/110
X3			Take-up Motor	DNA5230/75
TR3			Mains Transformer	T 1552A
FS1	2A		Fuse	BP/1253/F

OTE:—Throughout all lists \* values are nominal only. Actual values are selected during setting up.

## APPENDIX C

All 110 volt, 60 cycle, series 4 Ferrographs have the N.A.R.T.B. recording characteristic.

A complete circuit diagram of this model is shown in Fig. 24. The basic specification on page 2 remains the same but N.A.R.T.B. pre-recorded tapes can be reproduced with an overall response  $\pm 3\text{dB}$  over the frequency ranges given.

## APPENDIX D

The following accessories are available for use with the Ferrograph.

### **Stere-ad Unit**

When this is added to the model 4S, the combination requires only the addition of two 15 ohm loudspeakers to replay pre-recorded stereo tapes with an output of approximately 2 watts from each channel. This gives a total available output of 4 watts.

The Stere-ad unit consists essentially of a complete playback amplifier similar to that used in the standard Ferrograph, plus a two valve pre-amplifier. Both have high ratio input transformers to couple to the low impedance stereo head windings and a form of equalisation which will be that recommended by the CCIR for units manufactured for the European market, and N.A.R.T.B., for North and South America and Canada. Both equalisations are for  $7\frac{1}{2}$  ins/sec., the accepted international standard speed for pre-recorded stereo material. When in use with the model 4S, the output from the two valve pre-amplifier is coupled (via auxiliary socket 2) to input 2 on the Ferrograph internal amplifier, thus providing a complete amplifying channel with its own equalisation similar to the other in the Stere-ad unit.

Ganged gain controls and a balance control are provided on the Stere-ad front panel.

If it is desired to use the two amplifiers contained in the 4S—Stere-ad combination simply as amplifiers for any purpose, e.g., replaying stereo discs, this may be done by only a slight variation to the normal stereo tape playback arrangement.

### **Carrying Case for Series 4 and Stereo 88**

Best quality waterproof canvas with zip fastener. Gives full protection against rain and dust.

### **Defluxer**

For demagnetising the record/playback head. Prevents hiss and protects tapes from cumulative background noise.

### **Endless Loop Cassette**

As described in the Manual.

For Service Manuals Contact  
MAURITRON TECHNICAL SERVICES  
8 Cherry Tree Rd, Chinnor  
Oxon OX9 4QY  
Tel:- 01844-351694 Fax:- 01844-352554  
Email:- enquiries@mauritron.co.uk

## Appendix D : *continued*

### Low Impedance Microphones

Type RBL/TM, high fidelity, low impedance (30 ohms) fitted with 3 pin plug/socket mount for attaching to a floor, table or desk stand with 18 feet screened lead and plug, and incorporating matching unit in lead.

Type RBL/T, high fidelity, low impedance (30 ohms) microphone with 3 pin plug/socket mount and fitted with 18 ft. screened lead and plug.

### Microphone Stands

Heavy bases finished grey with chromium pillars. Desk model height 8 inches. Table model adjustable 16/24 inches. Floor model adjustable 3ft./5ft. 9 ins.

### Motor Pulley for 60 cycles/sec. Mains Supply

Converts the standard Ferrograph (50 cycles/sec) to 60 cycles/sec working. If the mains supply is 110/130 volts, the motor capacitor should be replaced by one of 2.5 mfd. capacitance.

### The following spares can also be supplied

Indicator Lamp	...	...	...	8v 0.3 amp. M.E.S. Cap.
Fuse	...	...	...	Belling Lee Type L1055/1.
Unscreened input plug	...	...	...	Igranic P.50 or equivalent.
Screened input plug	...	...	...	Ferrograph S.P.7.
External output plug	...	...	...	Igranic P.50 or equivalent.
Octal plug	...	...	...	Bulgin Q575 or equivalent.
Hublok Reels (empty)	...	...	...	200 ft. Ferrograph R.E.3. 600 ft. Ferrograph R.E.5. 1,200 ft. Ferrograph R.E.7. 1,750 ft. Ferrograph R.E.8.
Hublok Reels full Tape to WW372/49	...	...	...	200 ft. Ferrograph F.T.3A 600 ft. Ferrograph F.T.5A 1,200 ft. Ferrograph F.T.7A 1,750 ft. Ferrograph F.T.8A

NOTE :—Tape deck parts which may require replacement after long use or accidental damage are indicated in the illustrations. When ordering these, please specify the part number.

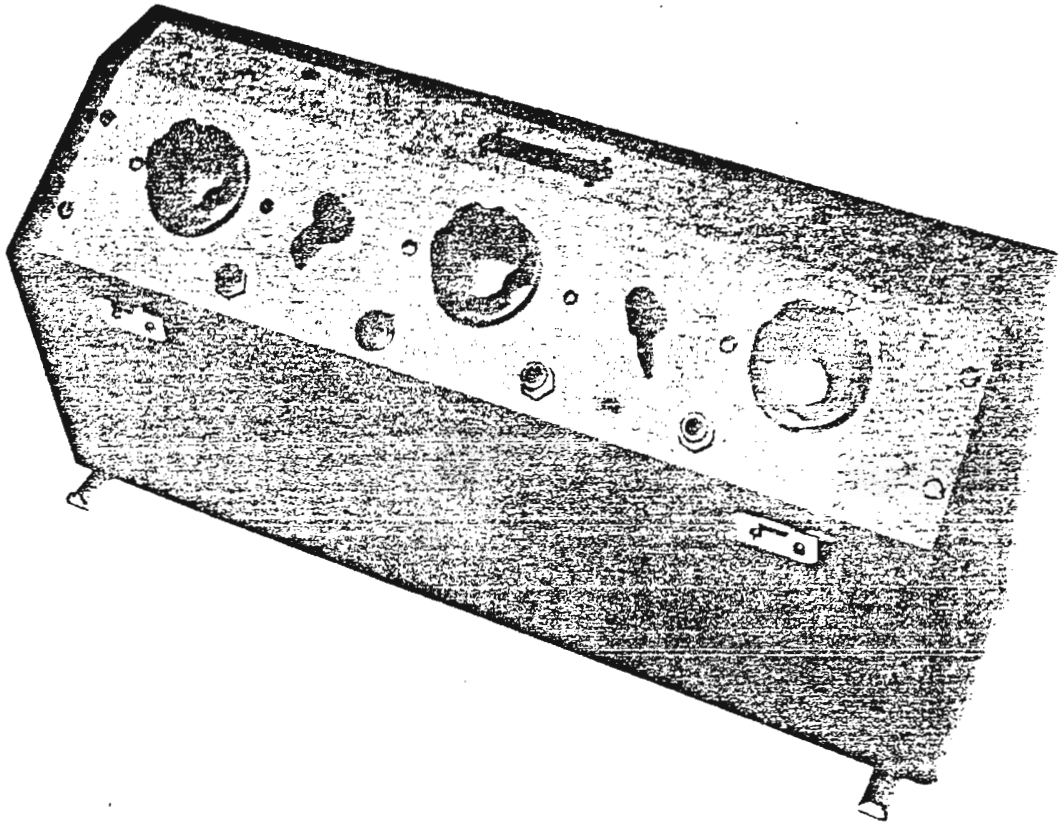

STERE-AD UNIT  
FIG. 22

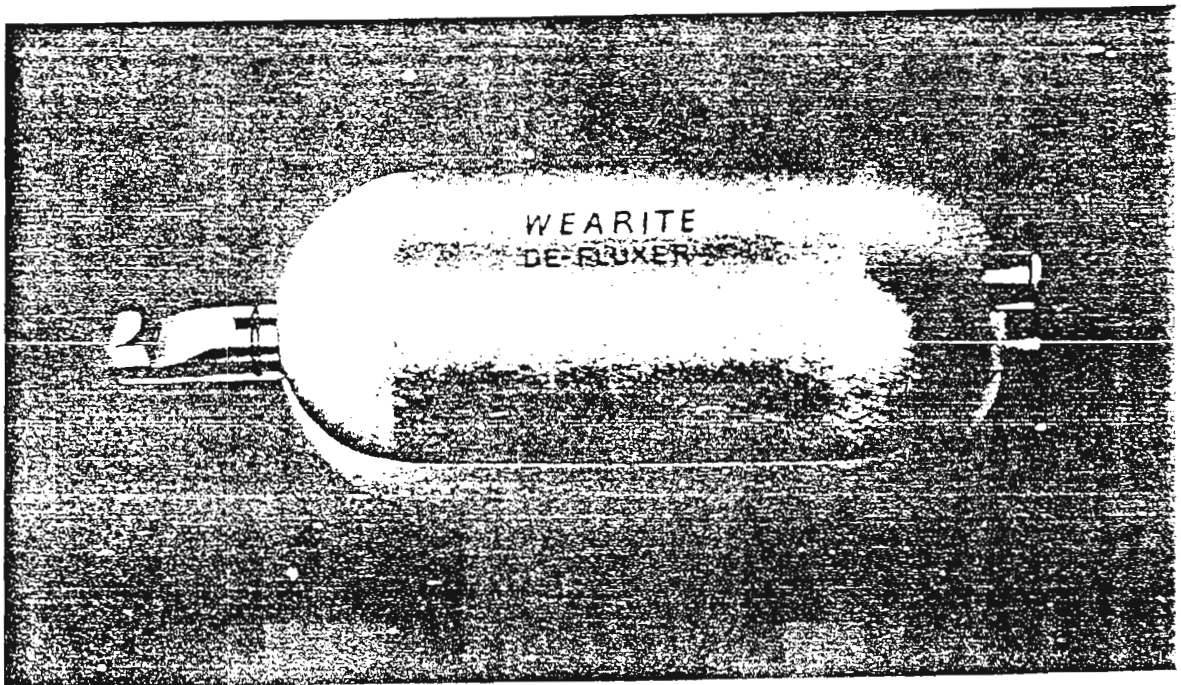

WEARITE DE-FLUXER  
FIG. 23



## APPENDIX E

### MAGNETIC SOUND RECORDING TAPE

SPEC. No. WW372/49

For the sake of completeness and as it is referred to in the General Specification, this appendix is included. Being originally drawn up in 1949 certain of the tolerances on physical dimensions quoted may not necessarily be identical with those since proposed as international standards.

### PERFORMANCE REQUIREMENTS

#### GENERAL

The object of this specification is to define the characteristics of a satisfactory standard *w* speed sound recording tape for use with the recording equipment manufactured by the company, and with which the overall published performance curves of the complete equipments can be maintained. It also seeks to ensure that tapes acceptable under it are interchangeable on the complete equipments within the scope of the manual adjustments provided.

The complete evaluation of the magnetic characteristics of a sound recording tape is a fairly lengthy and complex procedure. Its statement in terms of absolute units such as coercivity and remanence gives by no means the full picture, and the assessment of operational performance is therefore inseparable from tests made with a standard recording head.

It is on this basis of tests in conjunction with a standard recording head that this specification is drawn up. Wherever possible however properties are specified in terms of inter-related phenomena so that the influence of the head on the results is reduced to the minimum.

In reading the specification the following points should be borne in mind.

**1.1.** The specification is concerned only with the end result and not with the means used to obtain a specified performance. For example it does not concern itself with the type of oxide used nor with the individual thickness of the backing and the oxide coating, but only with the total overall thickness.

**1.2.** The figures quoted for the various outputs, distortion, etc. do not necessarily represent the operating conditions in complete equipments. For example under constant current recording conditions the 400 cycle harmonic distortion shown in the curves would be subject on playback equalization to a fair degree of attenuation, producing a somewhat lower apparent total distortion at this frequency.

**1.3.** The magnitude of the bias and signal inputs in this specification is specified in volts—contrary to the generally accepted method of expression in terms of current through the head. This system has been adopted because, particularly in the case of the bias, the applied voltage gives a truer indication of relative flux than current measurements which inevitably include variable loss factors.

To complete the data the high frequency response at frequencies of 7.5 Kc and 10 Kc shall be measured under a fixed 12v signal input condition but with the bias voltage varying in the same steps as for the low frequency test. For this test a new loop of tape shall be used in order to meet the requirements of 1.3. (Some care will here be necessary to ensure that the output readings are truly representative at the short wavelengths involved, and that indifferent threading and pad pressure are not adversely affecting results). These last tests will enable curves to be drawn showing the manner in which the output of the high frequencies fall off with increasing bias, and these curves should be plotted alongside those obtained for the low frequency performance, similar to those shown in Figs. 2 and 3. (Appendix).

Over these curves should be inscribed the 12v signal line of the low frequency grid by extending the reading on the 12v signal line for the various values of bias so that this will show the manner in which a 400 cycle signal of identical recording level behaves.

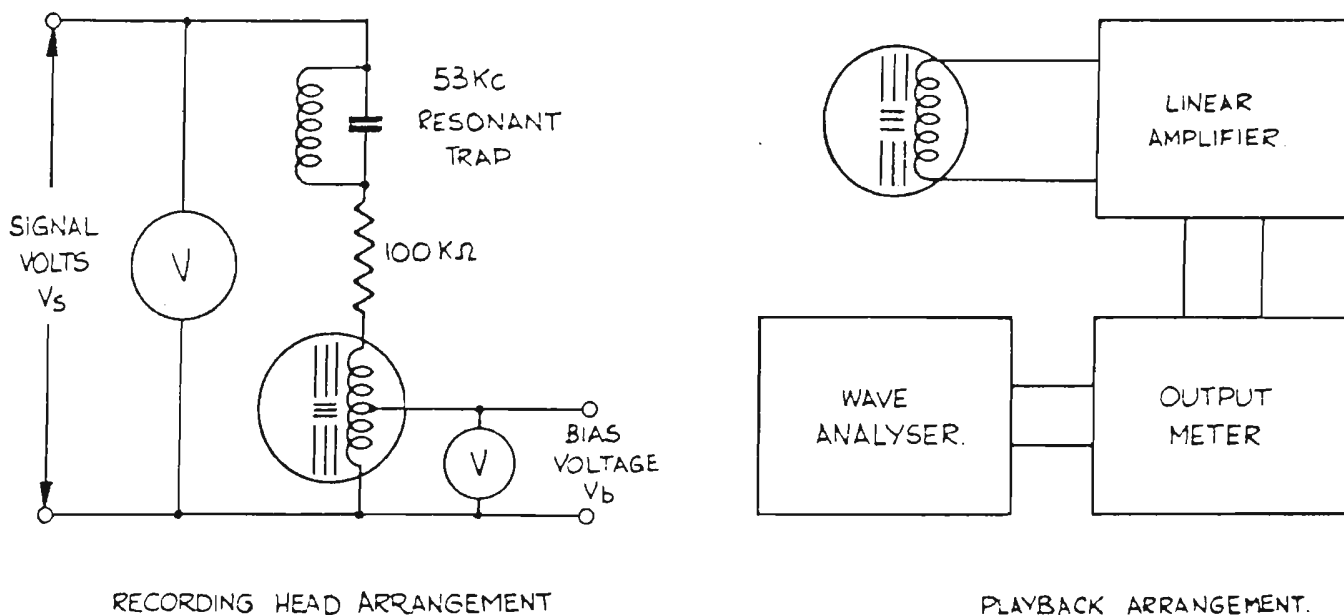

RECORDING HEAD ARRANGEMENT

PLAYBACK ARRANGEMENT.

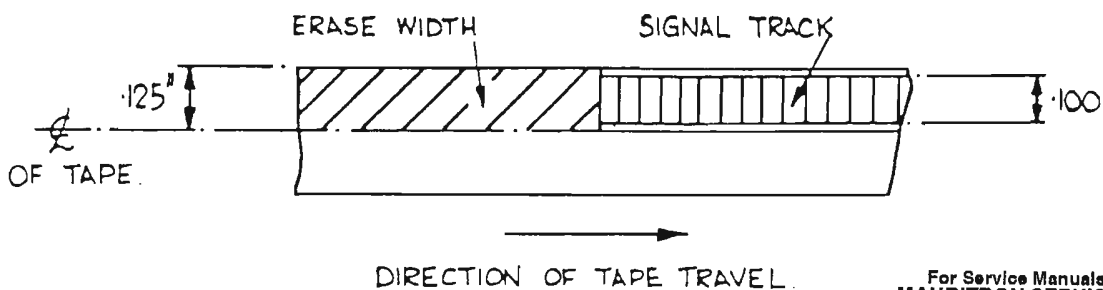

TRACK DISPOSITION  
(VIEWED FROM BACK OF TAPE)

FIG. 1. (APPENDIX E)

For Service Manuals  
**MAURITRON SERVICES** ;  
 8 Cherry Tree Road, Chinnor  
 Oxfordshire, OX9 4QY.  
 Tel (01844) 351694  
 Fax (01844) 352554  
 email:- mauritron@dial.pipex.com

From a family of curves thus prepared it is then possible to determine any particular operating condition. Insofar however as this specification is concerned it is dealing with a set of operating conditions already fixed by virtue of the fact that the machines with which the tape is to be used, will themselves be operating under pre-selected conditions of bias. For the purposes of this specification therefore 5% of third harmonic distortion shall be taken as a primary datum, and the 5% curve should therefore be superimposed on the right hand graph by extending to the right the readings obtained against the 5% harmonic line of the grid.

#### 4.2. Limits

From these curves the suitability of the tape for inclusion in the "A" category shall be judged according as to whether or not it passes the following requirements :—

4.2.1. The maximum response at 400 cycles as indicated by Point A on the 12v signal line of Figs. 2 and 3 shall occur at a bias voltage of between 15 and 17.

4.2.2. At the mean bias (16v) the maximum output for 5% distortion as shown by Point B on the curves shall not be less than 1 m.v.

4.2.3. The requirements of 4.2.2. above shall be met with an input signal not greater than 17v or less than 14v.

4.2.4. At the reference bias of 16v the ratio of the outputs at the various frequencies, as shown by Points A, C and D for 400, 7,500 and 10,000 c.p.s. respectively, shall be not less than the figures quoted hereunder.

$$\frac{C}{A} = .7 \qquad \frac{D}{A} = .3$$

#### 4.3. Consistency of Reproduced Level

The playback level of a 2,000 c.p.s. signal previously recorded at an applied signal level of 12v and bias of 16v, shall not have a peak to peak amplitude variation greater than 1 DB over periods of 10 seconds. Throughout the 1,200 ft. reel the mean level of the output shall not vary more than 1 DB.

#### 4.4 Splices

There shall be not more than one splice in a reel of 1,200 ft. and the requirements of 4.3. above shall be met as though no splice existed.

TYPICAL CURVES TAPE SAMPLE 'A'

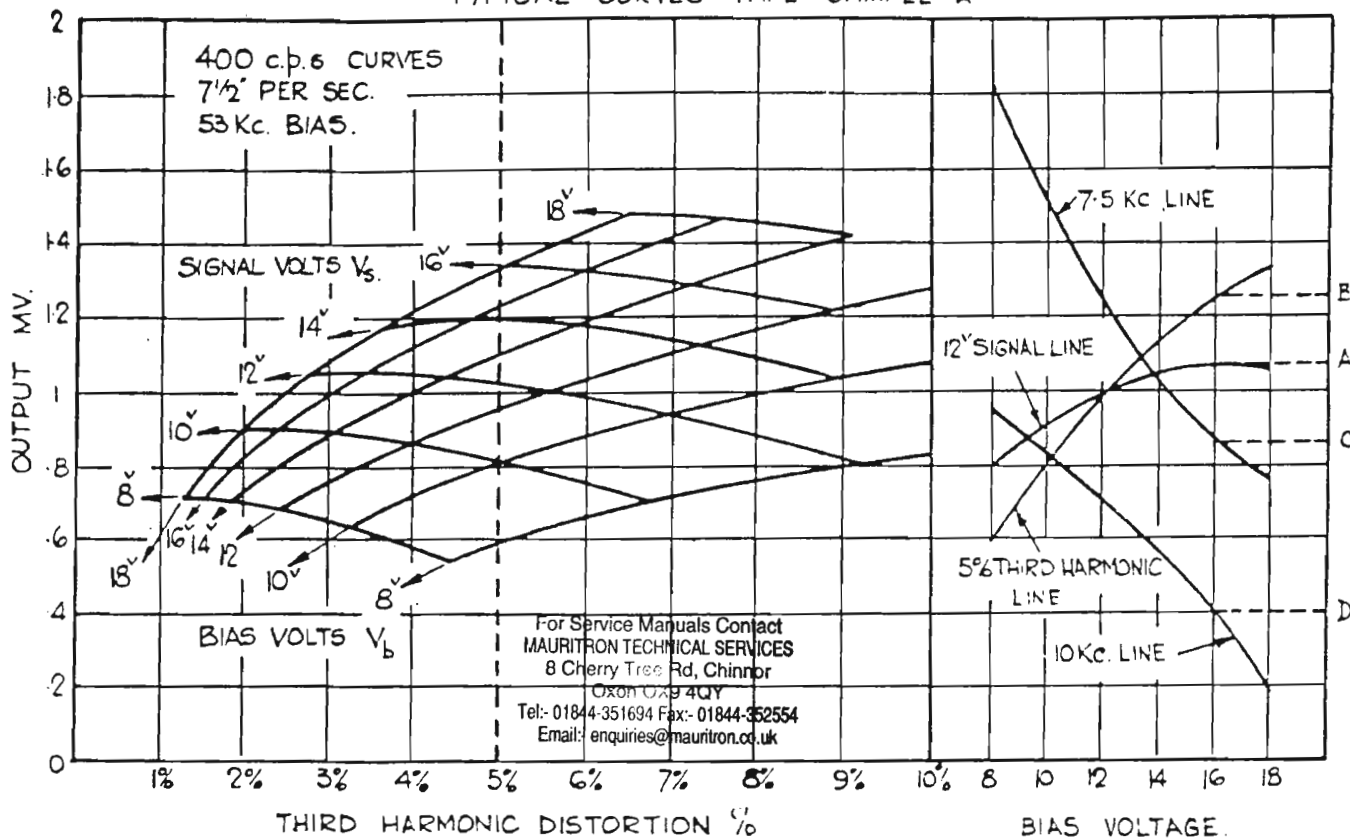

TYPICAL CURVES TAPE SAMPLE 'B'.

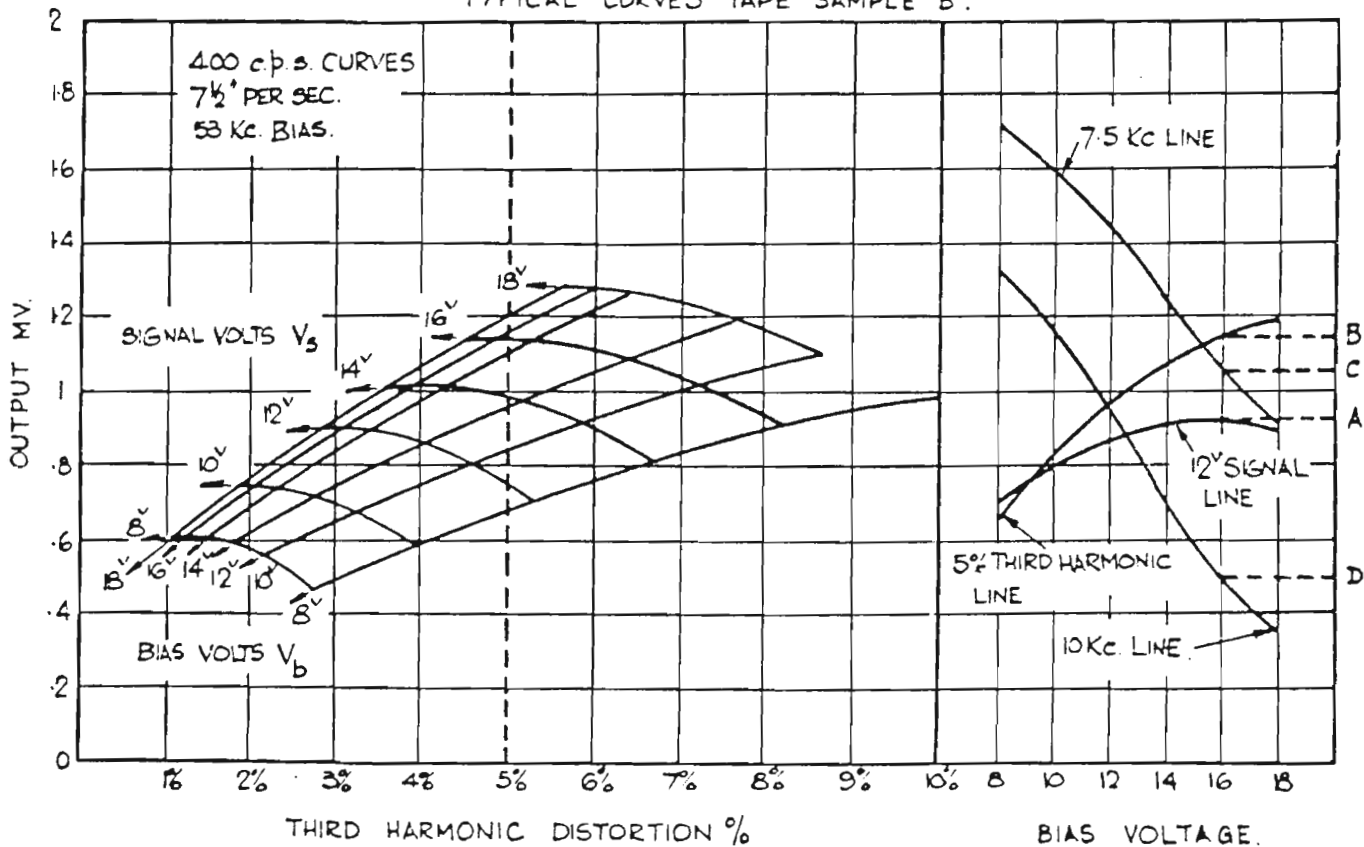

FIGS. 2 & 3 (APPENDIX E)

## 4.5. Noise

### 4.5.1. Polarized Noise

The tape shall be thoroughly erased by bulk erasing procedure in a 50 cycle field. It shall then be played back over the standard head and amplifier of the previous tests, but in this operation the playback head shall be subject to a polarizing field by having D.C. passed through its winding while playback is taking place. A current of 2 m.a. shall be passed through the bias winding of the head via a limiting resistor of not less than 12,000 ohms. The unweighted noise signal thus produced shall not exceed 13 microvolts on tape which passes the requirements of Test 4.2.

### 4.5.2. Limiting Noise

For this test the playback amplifier shall be equalized so that with the particular tape being tested an overall record/reproduce response, level within  $\pm 3$  DB from 70 to 9,000 cycles, is obtained when the recording network shown in Fig. 1 is modified so as to include a 250 pf capacitor shunted across the 100K resistor to give a fixed amount of pre-emphasis.

The reference level against which the noise is to be measured shall be that of the maximum 400 cycle signal output giving a distortion not exceeding 5%. After this measurement the tape shall then be thoroughly erased by a 50 cycle bulk erasing technique to give the best possible noise level and the playback head shall also be thoroughly demagnetized.

The noise voltage of the tape shall then be measured as the increment in output voltage from tape stopped, to tape running, when all components over 200 c.p.s. up to the high frequency end of the band as stated above are included. The ratio of noise output to maximum 5% distortion signal output shall be not less than 54 DB.

## SAFEGUARDS

Notwithstanding acceptance under all the clauses above, the tape shall not exhibit any characteristics either mechanical or electrical such as would cause its performance on complete instruments to fall outside the overall instrument performance.

For Service Manuals Contact  
MAURITRON TECHNICAL SERVICES  
8 Cherry Tree Rd, Chinnor  
Oxon OX9 4QY  
Tel:- 01844-351694 Fax:- 01844-352554  
Email:- enquiries@mauritron.co.uk

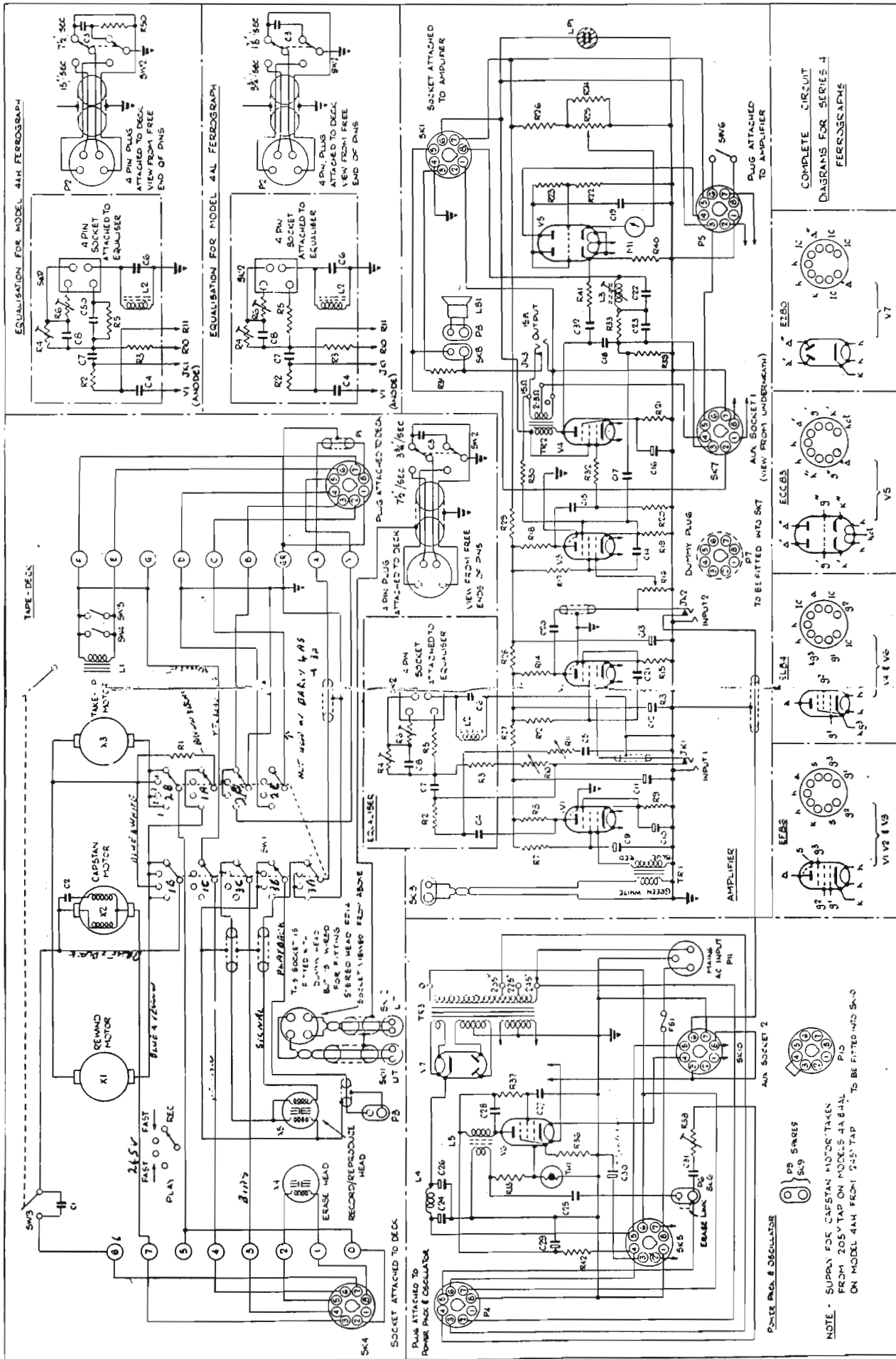

FIG. 20.

COMPLETE CIRCUIT  
DIAGRAMS FOR SERIES H  
FERROGRAPHS

NOTE - SUPPLY FOR CAPSTAN MOTOR TAKEN  
FROM 205V TAP ON MODEL 44B 44L  
ON MODEL 44H FROM 245V TAP TO BE FITTED INTO SK-3

POWER PLUG & OSCILLATOR

