

Service Manual

THE FISHER®

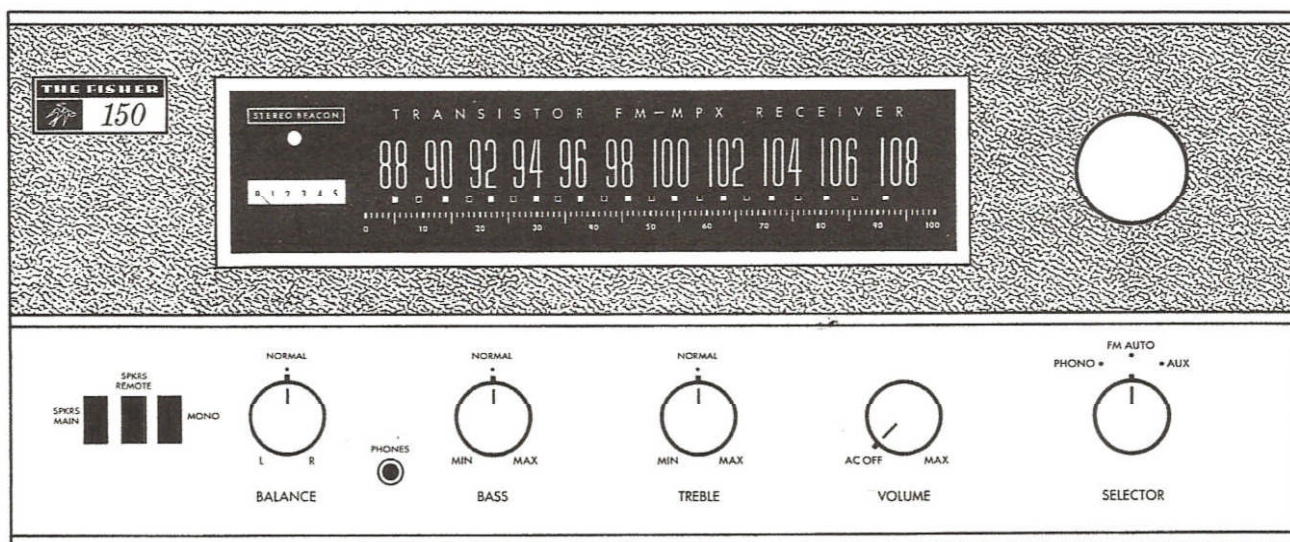

MODEL
150 AND

ALLEGRO
11R

CHASSIS SERIAL NUMBERS
BEGINNING 10001

CHASSIS

CHASSIS SERIAL NUMBERS
BEGINNING 30001

\$1.00

FISHER RADIO CORPORATION • LONG ISLAND CITY 1 • NEW YORK

CAUTION: This is a FISHER precision high-fidelity instrument. It should be serviced only by qualified personnel — trained in the repair of transistor equipment and printed circuitry.

TEST EQUIPMENT REQUIRED

The following are needed to completely test and align modern high-fidelity instruments such as amplifiers, tuners and receivers.

Vacuum-Tube Voltohmmeter
(100-mV DC scale)
Audio Vacuum-Tube Voltmeter
(10-mV AC scale)
Oscilloscope (Flat to 100 kHz Minimum)
Audio (Sine-Wave) Generator
Intermodulation Distortion Analyzer
Harmonic Distortion Analyzer
AM/FM Signal Generator
Multiplex Generator (preferably with RF output — FISHER Model 300 or equal)

10.7-MHz Sweep Generator
455-kHz Sweep Generator
Line Voltage Autotransformer
or Voltage Regulator
2 — Load Resistors, 4 or 8 Ohm, 50 Watt
2 — Full Range Speakers for Listening Tests
Stereo Source — Turntable or Tape Recorder
for Listening Tests
Soldering Iron with Small Tip
Fully Insulated from Power Line
Suction Desoldering Tool

PRECAUTIONS

Many of these items are included just as a reminder—they are normal procedures for experienced technicians. Shortcuts can be taken but often they cause additional damage — to transistors, circuit components or the printed-circuit board.

Soldering—A well-tinned, hot, clean soldering iron tip will make it easier to solder without damage to the printed-circuit board or the many circuit components mounted on it. It is not the wattage of the iron that counts — it is the heat available at the tip. Some 50-watt irons reach temperatures of 1,000° F — others will hardly melt solder. Small-diameter tips should be used for single solder connections — larger pyramid and chisel tips are needed for larger areas.

• When removing defective resistors, capacitors, etc., the leads should be cut as close to the body of the circuit component as possible. (If the part is not being returned for in-warranty factory replacement it may be cut in half — with diagonal-cutting pliers — to make removal easier.)

• Special de-soldering tips are made for unsoldering multiple-terminal units like IF transformers and electrolytic capacitors. By unsoldering all terminals at the same time the part can be removed with little chance of breaking the printed-circuit board.

• Always disconnect the chassis from the power line when soldering. Turning the power switch OFF is not enough. Power-line leakage paths, through the heating element, can destroy transistors.

Transistors—Never attempt to do any work on the transistor amplifiers without first disconnecting the AC linecord and waiting until the power supply filter-capacitors have discharged.

• Guard against shorts — it takes only an instant for a base-to-collector short to destroy that transistor and possibly others direct-coupled to it. [In the time it takes for a dropped machine screw, washer or even the screwdriver, to glance off a pair of socket terminals (or between a terminal and the chassis) a transistor can be ruined.]

• DO NOT bias the base of any transistor to, or near, the same voltage applied to its collector.

• DO NOT use an ohmmeter for testing transistors. The voltage applied through the test probes may be higher than the base-emitter breakdown voltage of the transistor.

Output Stage and Driver — Replacements for output and

driver transistors, if necessary, must be made from the same beta group as the original type. The beta group is indicated by a colored dot on the mounting flange of the transistor. Be sure to include this information, when ordering replacement transistors.

• If one output transistor burns out (open or shorts), always remove ALL output transistors in that channel and check the bias adjustment, the control and other parts in the network with an ohmmeter before inserting a new transistor. All output transistors in one channel will be destroyed if the base biasing circuit is open on the emitter end.

• When mounting a replacement power transistor be sure the bottom of the flange, the mica insulator and the surface of the heat sink are free of foreign matter. Dust and grit can prevent perfect contact reducing heat transfer to the heat sink. Metallic particles can puncture the insulator and cause shorts — ruining the transistor.

• Silicone grease must be used between the transistor and the mica insulator and between the mica and the heat sink for best heat conduction. (Use Dow-Corning DC-3 or C20194 or equivalent compounds made for power transistor heat conduction.)

• Use care when making connections to speakers and output terminals. Any frayed wire ends can cause shorts that may burn out the output transistors — they are direct-coupled to the speakers. To reduce the possibility of shorts at the speakers, lugs should be used on the exposed ends or at least the ends of the stranded wires should be tinned to prevent frayed wire ends. The current in the speakers and output circuitry is quite high. Poor contacts or small size wire can cause power losses in the speaker system. Use 14 or 16 AWG for long runs of speaker wiring.

Voltage Measurements—Voltage measurements are made with the line voltage adjusted to 117 volts and all readings are $\pm 10\%$. All voltages are DC, measured with a VTVM to ground, with no signal input unless otherwise noted. \square indicates 1-kHz audio voltages, measured with an audio AC VTVM to ground at various points from the phono input to the power amplifier output.

Alignment Procedures — Replacement of transistors and components in the front end, IF amplifier and multiplex decoder will normally not require realignment of these circuits. Realignment of these circuits, unless absolutely necessary, is not recommended. Do not attempt a realignment unless the required test equipment is available and the alignment procedure is thoroughly understood.

SERVICE PROCEDURES

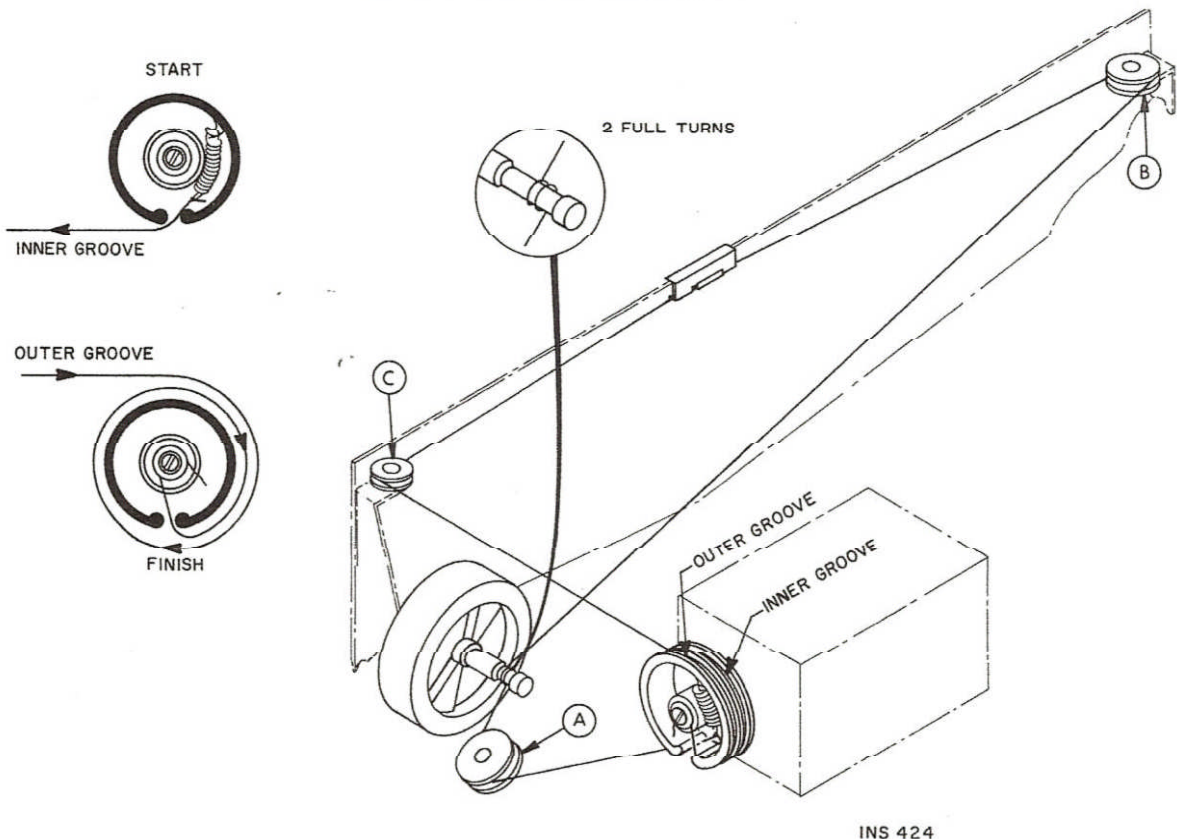

DIAL STRINGING

- Rotate tuning capacitor drive drum to its maximum clockwise position.
- Tie one end of the dial cord to the end of the spring. Attach the spring to the ear inside the top front of the drive drum.
- Run the dial cord through the slot in the rim of the drive drum and set the dial cord in the underside of the inner groove.
- Guide the dial cord around pulley A.
- Wrap two complete turns of dial cord around the flywheel shaft.
- Guide the dial cord around pulleys B and C.
- Pull the dial cord taut slightly stretching the spring. Set the dial cord in the topside of the outer groove and wrap 1½ turns of dial cord around the drive drum.
- Run the dial cord through the slot in the rim of the drive drum and under the beveled washer. Keeping the dial cord taut, tighten the machine screw to hold the dial cord.
- Place the dial cord over and under the tabs on the rear of the dial pointer. Place the dial pointer on the top of the chassis front panel.

REPLACING METER LAMP

- Disconnect AC power cord.
- Remove bolts which hold set in the cabinet and slide the set out of the cabinet from the front.
- Gently push in on the lamp and turn it counterclockwise to remove. Remove the metal lamp shade and place it on the new lamp in the same position. Place the new lamp in the socket, push in gently and turn it clockwise to lock it in place.
- Replace the set in the cabinet and secure with the bolts removed previously.

REPLACING STEREO BEACON LAMP

- Disconnect AC power cord.
- Remove bolts which hold set in the cabinet and slide the set out of the cabinet.
- Pry nylon lamp holder from the lamp mount. Unsolder the leads from the lamp holder. Solder leads to rear terminals on the new lamp holder. Place new lamp holder in the mount.
- Replace the set in the cabinet and secure with the bolts removed previously.

REPLACING DIAL LAMPS

- Disconnect AC power cord.
- Gently pull all knobs off the front panel control shafts. Remove the hex nuts from the control shafts and lift off the front panel.
- Snap out the defective lamp from the spring clip. Place the new lamp in the socket making sure that the unpainted side of the lamp faces the edge of the dial glass.
- Replace the front panel and secure with the hex nuts removed previously. Replace the knobs on the control shafts.

CLEANING DIAL GLASS

- Disconnect AC power cord.
- Gently pull all knobs off the front panel control shafts. Remove the hex nuts from the control shafts and lift off the front panel.
- If there are foam-cushion strips located at the ends of the dial glass, remove them.
- Loosen the screws that hold the retaining clips to the dial glass. Swing the clips aside and lift off the dial glass.
- Remove dust with a dry cloth. If you wish to clean more thoroughly, use a soap-and-water solution only; any stronger cleaning agent may damage the markings on the glass.

- Replace the dial glass and position it down and towards the left of the chassis front. Swing the retaining clips back into place and tighten the retaining-clip screws. Replace the foam-cushion strips, if removed previously.
- Replace the front panel and secure with the hex nuts removed previously. Replace the knobs on the control shafts.

CLEANING FRONT PANEL

WARNING: Use only plain lukewarm water and a freshly laundered, soft lint-free cloth to clean the front control panel.

FRONT END ALIGNMENT

NOTE: IF alignment must be performed before starting this procedure.

Set SELECTOR switch to FM AUTO.

- Set TUNING dial pointer to zero (0) calibration mark on the logging scale. If the dial pointer does not coincide with the 0 at the extreme end of the knob rotation, reposition the pointer assembly on the dial cord and cement the pointer in place to prevent slippage.
- Connect DC VTVM to the Test Point 303.
- Connect an RF generator to the NORM antenna terminals. Use a 120-ohm composition resistor in series with each lead from the generator—see Figure 1.
- Set RF generator frequency and TUNING dial pointer to 90 MHz (Mc). DO NOT USE MODULATION (AM or FM) and keep the generator output as low as possible during the alignment procedure.
- Align the oscillator coil (L755) first—then align the RF and antenna coils (L754, L753, L751) for maximum reading on DC VTVM.
- Set generator frequency and TUNING dial pointer to 106 MHz (Mc).
- Adjust oscillator trimmer (C769) first—then adjust RF and antenna trimmers (C768, C761, C753) for maximum reading on DC VTVM.
- Repeat alignment several times until accurate dial calibration and maximum gain are obtained. Keep the generator output as low as possible during all adjustments.

IF ALIGNMENT

- Connect scope to Test Point 301 on IF board through a 220K ohm resistor. Connect a 1000 pF capacitor across the scope's vertical input terminal and the vertical input ground terminal.
 - Connect 10.7MHz (Mc) sweep generator to Test Point 751 on front end.
- NOTE:** Connect ground lead of generator to ground of Test Point 751 and ground of scope probe to ground closest to scope input.

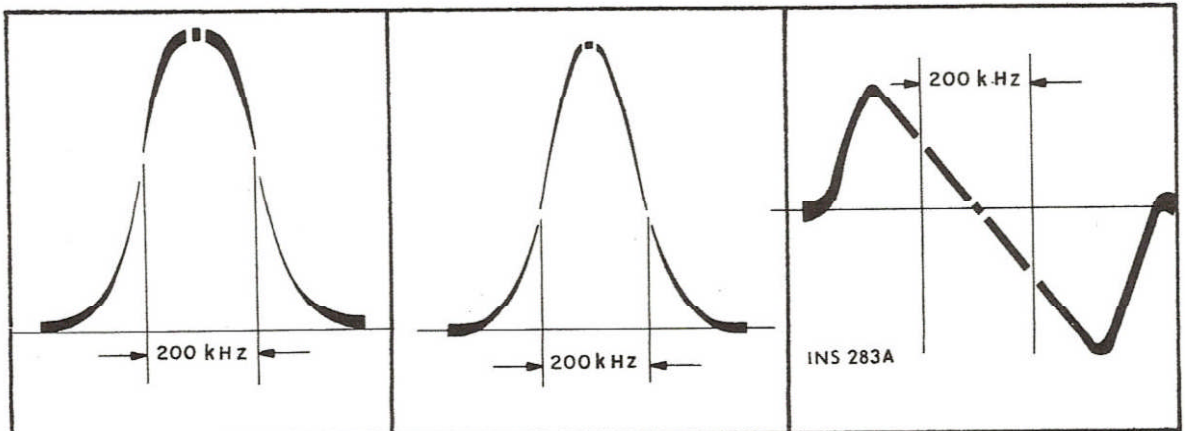

FIGURE 2.

FIGURE 3.

FIGURE 4.

- Align the top and bottom cores of IF transformer Z751 on the front end for maximum gain and symmetrical IF response (Figure 2).
- Adjust primary and secondary cores of IF transformers Z301, Z302 and Z303 for maximum gain and symmetrical IF response—see Figure 2.
- Connect oscilloscope to Test Point 303 on the main chassis.
- Adjust coil L1 on the main chassis for maximum gain and symmetrical response—see Figure 3.
- Reconnect oscilloscope to Test Point 301 and readjust primary and secondary cores of Z303 as necessary to maintain maximum gain and symmetrical IF response.
- Connect oscilloscope to Test Point 302 on the main chassis.
- Adjust primary and secondary cores of transformer Z304 for maximum gain and symmetrical ratio detector response—see Figure 4.
- Adjust Pot. R318 on IF board to its mechanical center.

RATIO DETECTOR ALIGNMENT

- Connect harmonic distortion analyzer to either the right or left RCDR jack.
- Connect FM generator modulated by 400 Hz (cps), ± 75 kHz (kc) deviation, to the NORM antenna terminals. Use a 120-ohm composition resistor in series with each lead from the generator.
- Set RF generator and TUNING dial pointer to 98 MHz (Mc) and adjust the generator output to 100 μ V.
- Align ratio detector transformer Z304 primary and secondary cores for maximum audio output reading.
- Readjust secondary coil core for minimum distortion, below 1% total harmonic distortion on the meter.

TUNING METER ADJUSTMENT

- Connect FM generator modulated by 400 Hz (cps), ± 22.5 (kc) deviation, to the NORM antenna terminals. Use a 120-ohm composition resistor in series with each lead from the generator.
- Set RF generator and TUNING dial pointer to 98 MHz (Mc) and adjust the generator output to 200 mV.
- Adjust Meter Adjust Pot. R16 for reading on tuning meter between 4 and 5.

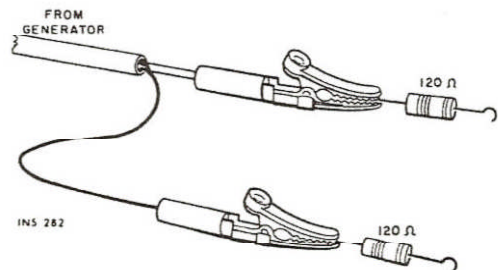

FIGURE 1. GENERATOR CONNECTIONS.

MULTIPLEX ALIGNMENT

Two methods of aligning the multiplex decoder are given. The preferred procedure uses a multiplex decoder with RF and 19 kHz (kc) outputs and with 1 kHz (kc) modulation, such as the Fisher Model 300 Multiplex Generator. This is the better method of alignment since the front end and IF stages are also checked through the use of this procedure. An alternate procedure for use with multiplex generator not having an RF output is also given.

PREFERRED ALIGNMENT PROCEDURE

Set SELECTOR switch to FM AUTO and the MONO switch to the out position.

● Connect multiplex generator to the NORM antenna terminals. Use a 120-ohm composition resistor in series with each lead from the generator.

● Follow procedures given in Table 1 below.

NOTE: Check the alignment of the IF amplifier before aligning the MPX decoder. Poor IF alignment can make proper multiplex adjustment impossible.

ALTERNATE ALIGNMENT PROCEDURE

Set SELECTOR switch to FM AUTO and the MONO switch to the out position.

● Disconnect lead going to connection 4P on the multiplex board. Connect multiplex generator to connection 4P through the low-pass filter shown in Figure 1.

● Follow procedures given in Table 2 below.

● After alignment, disconnect generator and low-pass filter and reconnect lead coming from connection 3E on the IF board to connection 4P on the multiplex board.

PREDRIVER/DRIVER OUTPUT ADJUSTMENT

Set BALANCE, BASS and TREBLE controls to their center positions. Push the SPEAKERS MAIN switch to the in position and make certain that the MONO switch is in the out position. Set SELECTOR switch to AUX. Unplug AC power cord.

● Connect a 4-ohm, 25-watt resistor wired to a RETMA phono plug to the LEFT MAIN SPEAKERS jack. In parallel with the resistor, connect the vertical input leads of an oscilloscope and a harmonic distortion analyzer.

● Connect an audio sine wave generator, set for 1000 Hz, to the AUX L jack.

● Connect AC power cord and rotate VOLUME control to its maximum clockwise position—full volume.

● Increase generator output until sine wave on scope just starts to clip. Adjust DC Bias Adjust Pot. R302 on the left channel predriver/driver board for equal clipping on the positive and negative half cycles of the signal with minimum harmonic distortion.

● Repeat preceding steps for right channel.

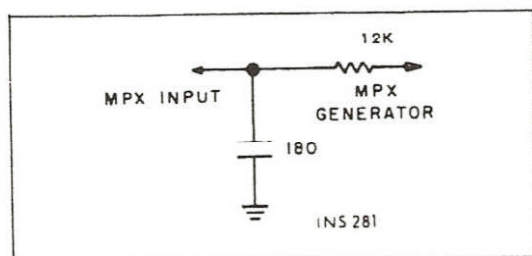

FIGURE 1. LOW-PASS FILTER CIRCUIT.

TABLE 1 - MULTIPLEX ALIGNMENT USING RF MULTIPLEX SIGNAL

STEP	GENERATOR MODULATION	RF DEV.	INDICATOR TYPE AND CONNECTION	ALIGNMENT	
				ADJUST	INDICATION
1	70 to 76kHz (kc) (connect external audio generator to SCA input of multiplex generator).	±25kHz (kc)	Audio (AC) VTVM input to Test Point 404 with 10-pF capacitor in series with lead.	-	Minimum AC VTVM reading.
2	19kHz (kc) pilot only.	±7.5kHz (kc)	AC VTVM to Test Point 403.	Z401, 402, 403 and 404	Maximum AC VTVM reading.
3	Same as Step 3.	±7.5kHz (kc)	-	Trigger Control	Until Stereo Beacon lights up.
4	Composite MPX signal 1kHz (kc) on left channel only.	±75kHz (kc)	Audio (AC) VTVM and scope input to left channel output on preamp board.	Z401, 402	Maximum audio AC VTVM reading; clean 1kHz (kc) sine wave on scope.
5	Composite MPX signal 1kHz (kc) on right channel only.	±75kHz (kc)	Same as Step 4.	MPX Separation Control*	Minimum audio AC VTVM reading - at least 30 db below reading obtained in Step 4.
6	Same as Step 5.	±75kHz (kc)	Audio (AC) VTVM and scope input to right channel output on preamp board.	-	Same audio AC VTVM reading as obtained in Step 4 - at least 30 db below reading obtained in Step 4; clean 1kHz (kc) sine wave on scope.
7	Same as Step 4.	±75kHz (kc)	Same as Step 6.	-	Minimum audio AC VTVM reading - at least 30 db below reading obtained in Step 6.

*NOTE: Separation Control is located on preamp board.

INTERMODULATION DISTORTION TEST

Set BALANCE, BASS and TREBLE controls to their center positions. Push the SPEAKERS MAIN switch to the in position and make certain that the MONO switch is in the out position. Set SELECTOR switch to AUX. Unplug AC power cord.

- Connect a 4-ohm, 25-watt resistor wired to a RETMA phono plug to the LEFT MAIN SPEAKERS jack. In parallel with the resistor, connect the input leads of an IM (Intermodulation) distortion analyzer and the leads of an AC VTVM capable of reading 0.1 volts with accuracy.
- Connect IM-analyzer generator output to the AUX L jack.
- Connect AC power cord and rotate VOLUME control to its maximum clockwise position—full volume.
- Increase IM-analyzer generator output for 5 watts output (9.0 VAC across 4-ohm load resistor). IM meter should read less than 0.6%.
- Repeat preceding steps for right channel.

NOTE: If any of the preceding instructions are different from those supplied with the IM analyzer instruction manual, it is best to follow those in the manual. If a load resistor of 25-watt rating is built into the IM analyzer, a separate load resistor is not required.

HARMONIC DISTORTION TEST

Set BALANCE, BASS and TREBLE controls to their center positions. Push the SPEAKERS MAIN switch to the in position and make certain that the MONO switch is in the out position. Set SELECTOR switch to AUX. Unplug AC power cord.

- Connect a 4-ohm, 25-watt resistor wired to a RETMA phono plug to the LEFT MAIN SPEAKERS jack. In parallel with the resistor, connect the input leads of a harmonic distortion analyzer and the leads of an AC VTVM capable of reading 0.1 volts with accuracy.

- Connect a low-distortion audio sine wave generator, set for 1000 Hz, to the AUX L jack.
- Connect AC power cord and rotate VOLUME control to its maximum clockwise position—full volume.
- Increase generator input to set for 10 watts output (6.3 VAC across 4-ohm load resistor). Harmonic distortion meter should read less than 0.5%.
- Repeat preceding steps for right channel.

POWER OUTPUT MEASUREMENT

The power output stage of this unit is designed to deliver its full-rated power with program material (voice or music) into 8 to 16-ohm loads for indefinite periods.

When a constant audio tone is used as a signal to measure the continuous RMS power output, the following precautions must be taken:

- Measure the power output of one channel at a time.
- Limit the measurement period to 10 minutes with a load resistance between 8 and 16 ohms.

If the power output of both channels must ever be measured simultaneously, use a load of 8 ohms per channel and limit measurement to a period not longer than 5 minutes.

TABLE 2 - MULTIPLEX ALIGNMENT USING COMPOSITE MULTIPLEX SIGNAL

STEP	GENERATOR MODULATION	LEVEL (RMS)	INDICATOR TYPE AND CONNECTION	ALIGNMENT	
				ADJUST	INDICATION
1	70 to 76kHz (kc) (connect external audio generator to SCA input of multiplex generator).	100mV	Audio (AC) VTVM input to Test Point 404 with 10-pF capacitor in series with lead.	-	Minimum AC VTVM reading.
2	19kHz (kc) pilot only.	50mV	AC VTVM to Test Point 403.	Z401, 402, 403 and 404	Maximum AC VTVM reading.
3	Same as Step 2.	50mV	-	Trigger Control	Until Stereo Beacon lights up.
4	Composite MPX signal 1kHz (kc) on left channel only.	300mV	Audio (AC) VTVM and scope input to left channel output on preamp board.	Z401, 402	Maximum audio AC VTVM reading; clean 1kHz (kc) sine wave on scope.
5	Composite MPX signal 1kHz (kc) on right channel only.	300mV	Same as Step 4.	MPX Separation Control *	Minimum audio AC VTVM reading - at least 30 db below reading obtained in Step 4.
6	Same as Step 5.	300mV	Audio (AC) VTVM and scope input to right channel output on preamp board.	-	Same audio AC VTVM reading as obtained in Step 4 (+2db); clean 1kHz (kc) sine wave on scope.
7	Same as Step 4.	300mV	Same as Step 6.	-	Minimum audio AC VTVM reading - at least 30 db below reading obtained in Step 6.

* NOTE: Separation Control is located on preamp board.

FE50D/97-2 FM FRONT END

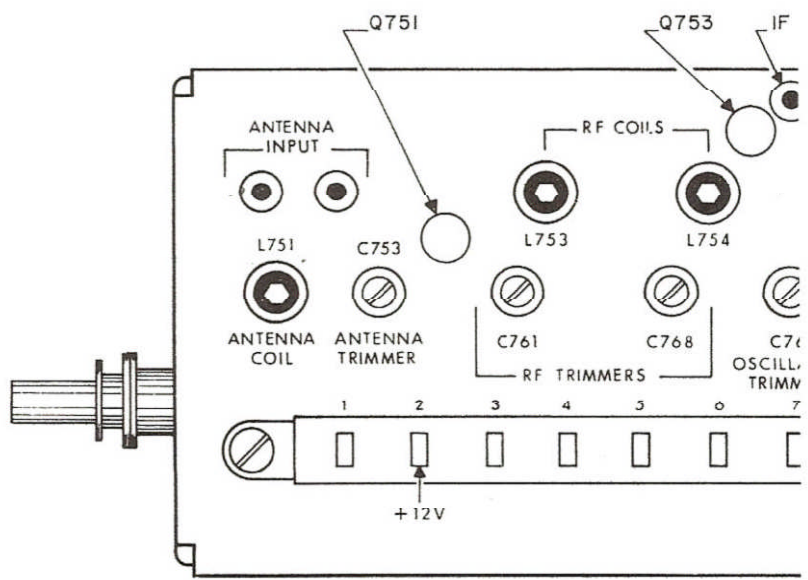
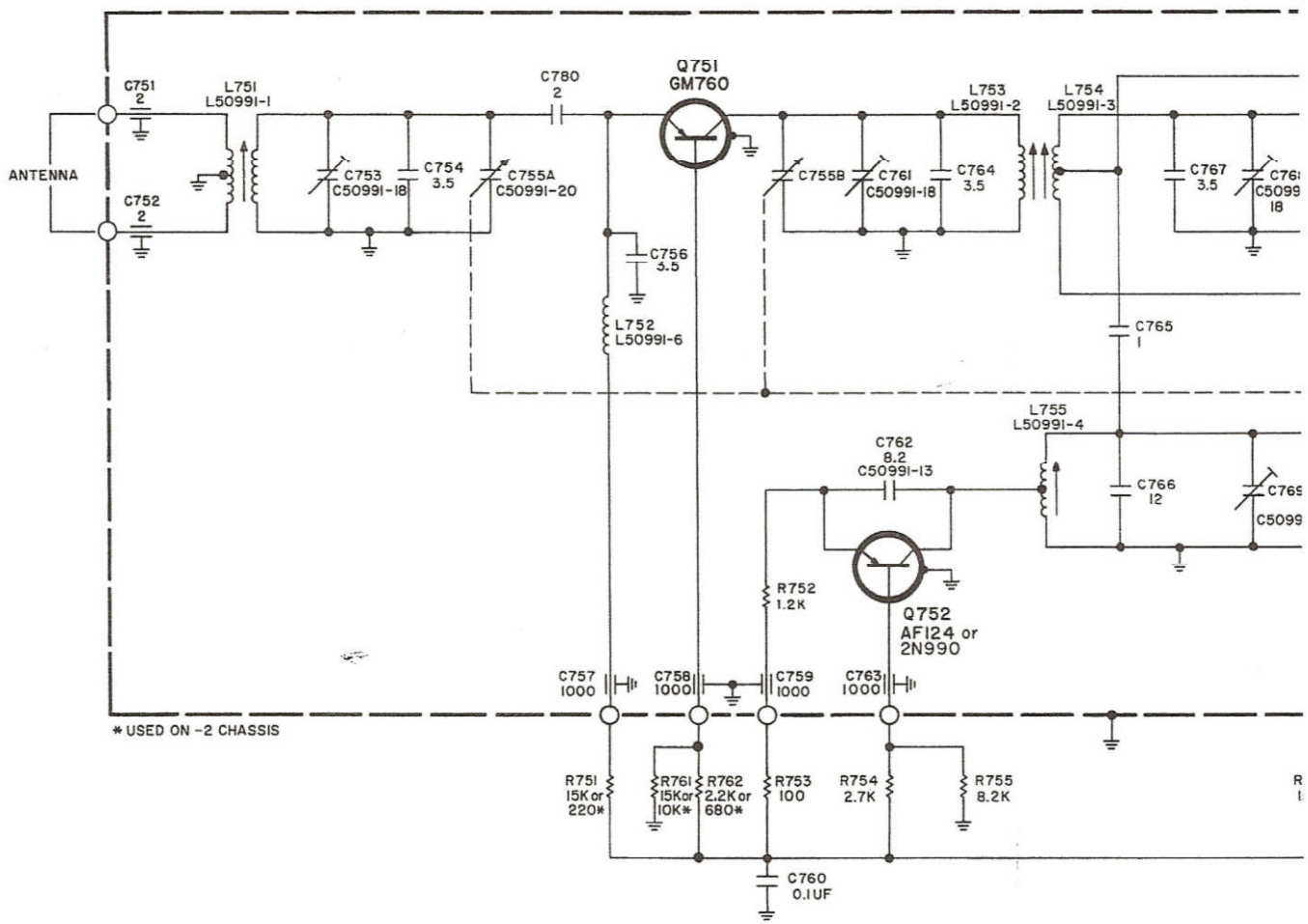

FM FRONT END

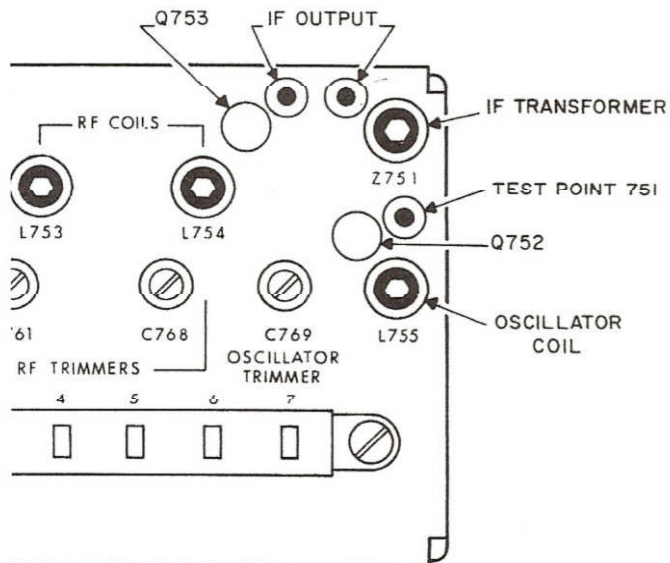
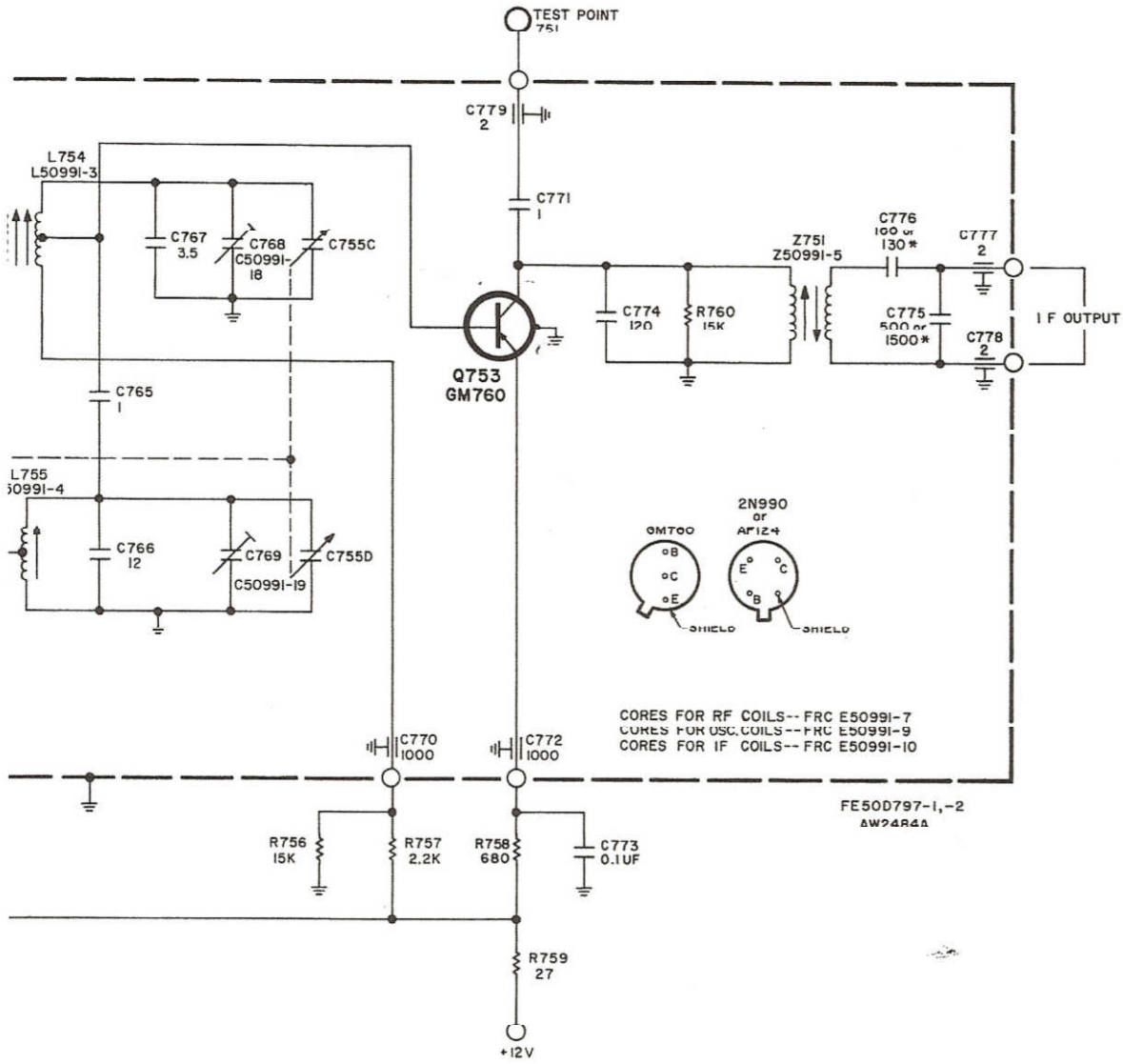

1398-2 PREAMPLIFIER

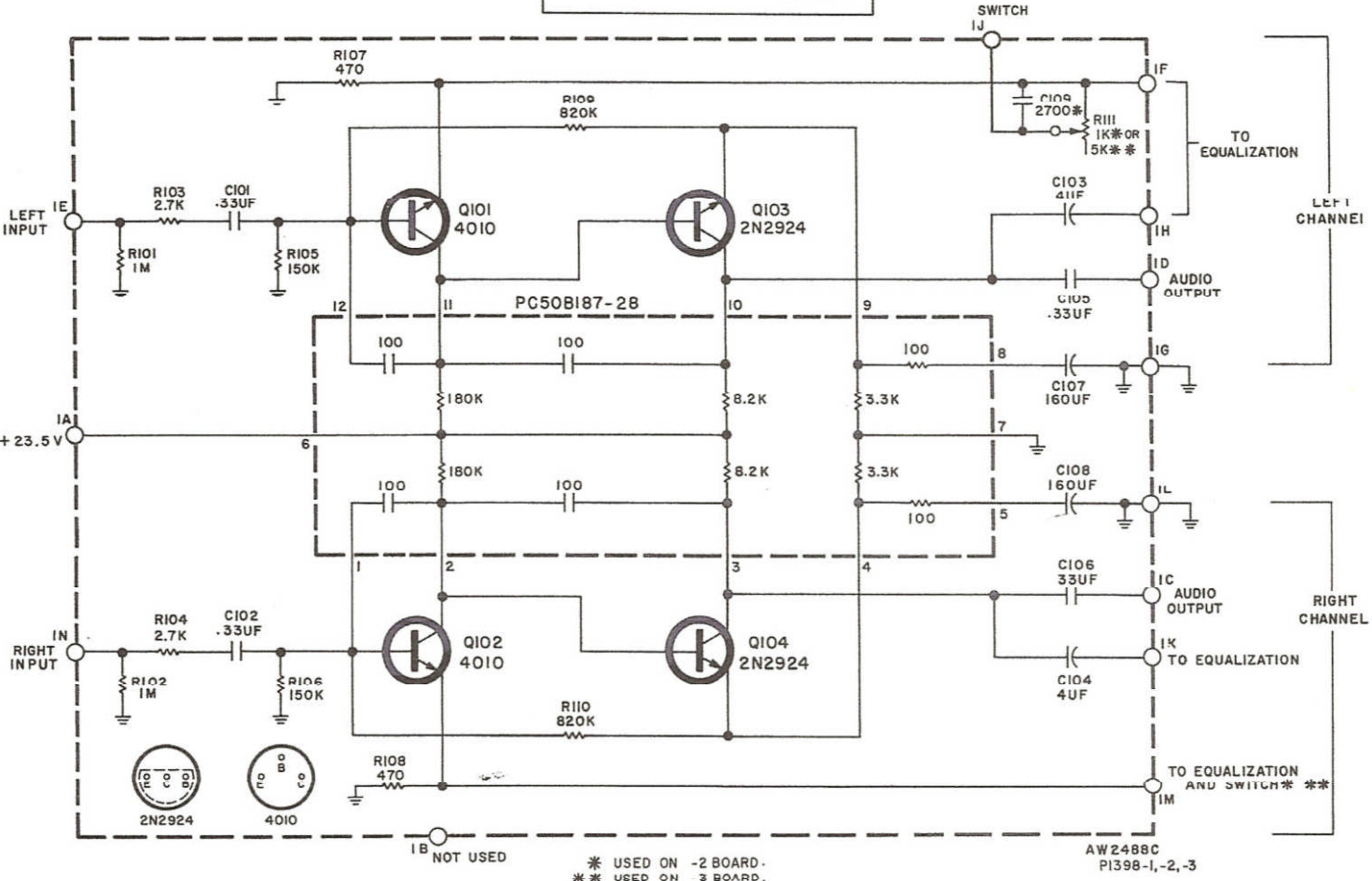

BOARD VIEWED FROM THE COMPONENT SIDE

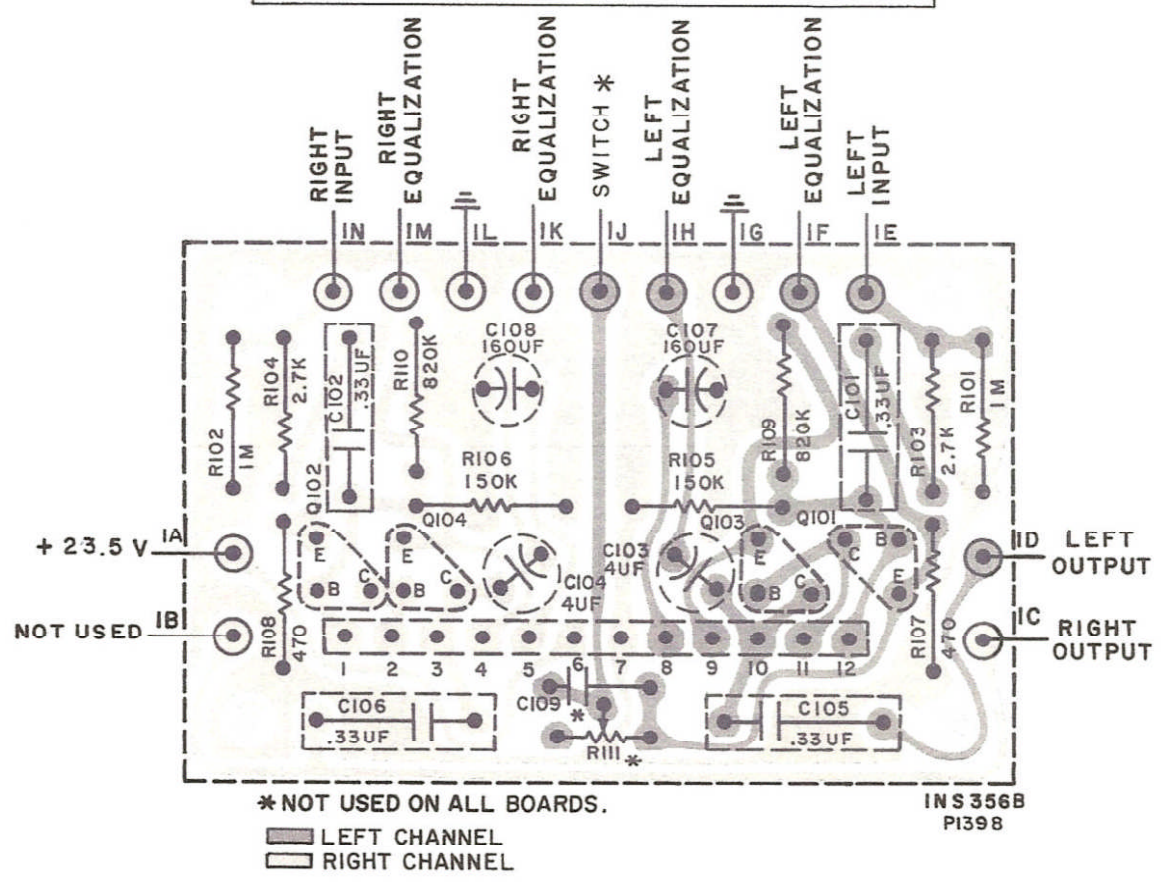

1374-2 PREDRIVER/DRIIVER

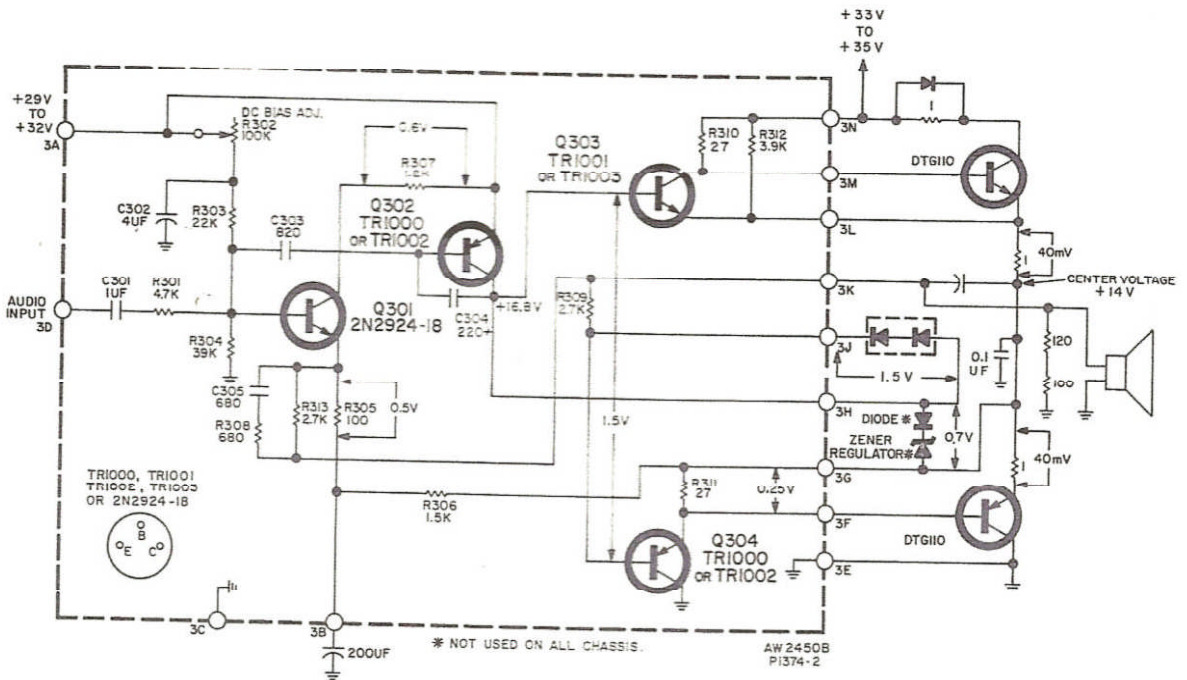

BOARD VIEWED FROM THE COMPONENT SIDE

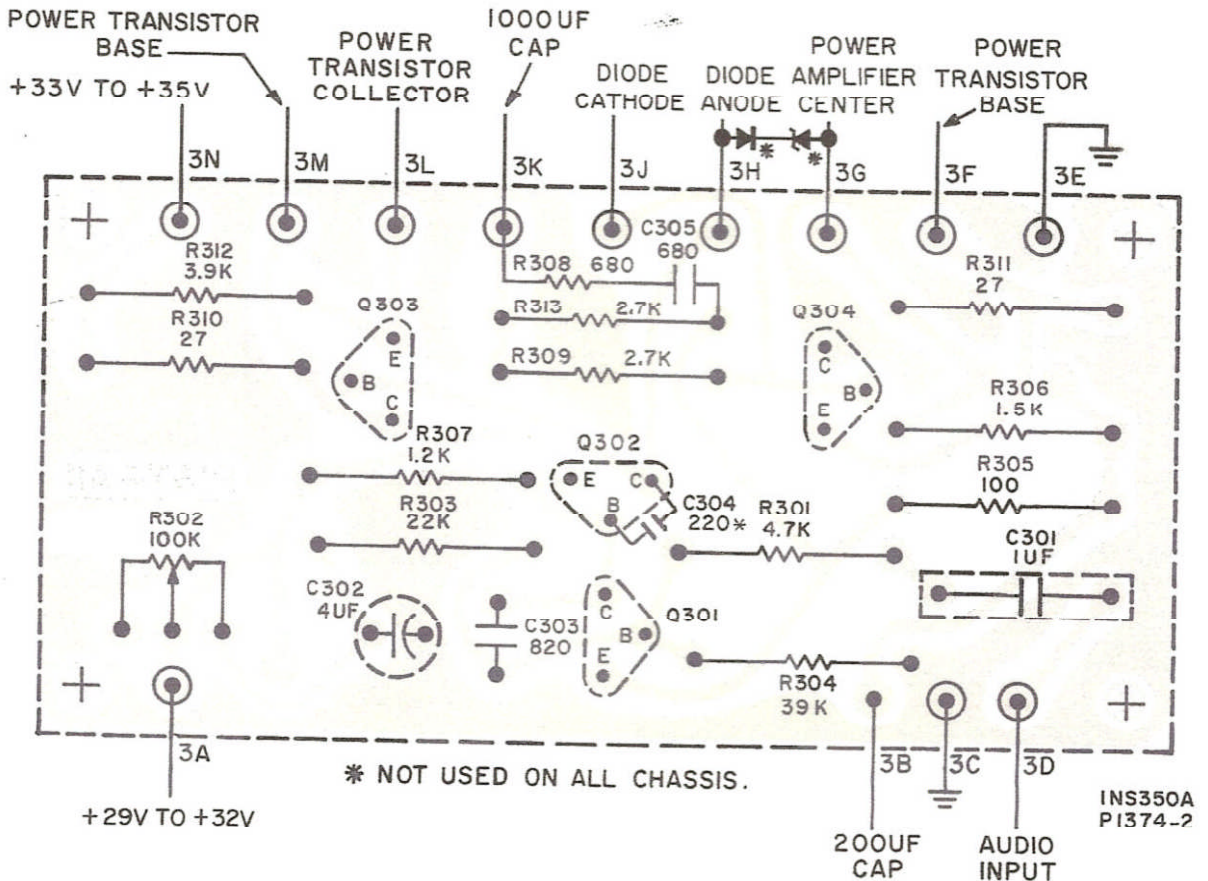

INS350A
P1374-2

MODEL 5 SPEAKER SYSTEM

USED ON MODEL 150 ONLY

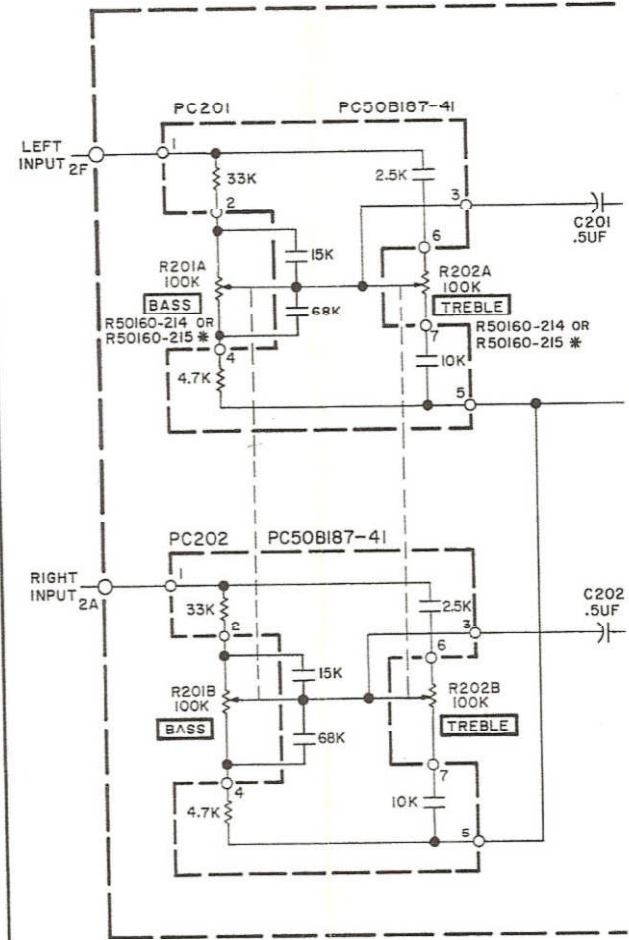
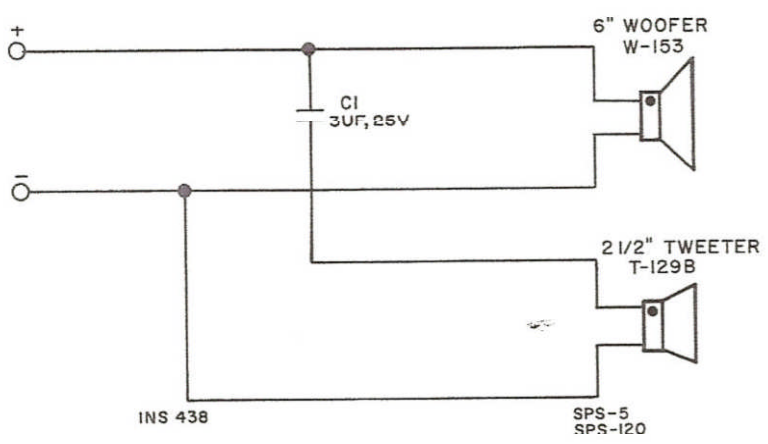

* USED ON -2 BOA1

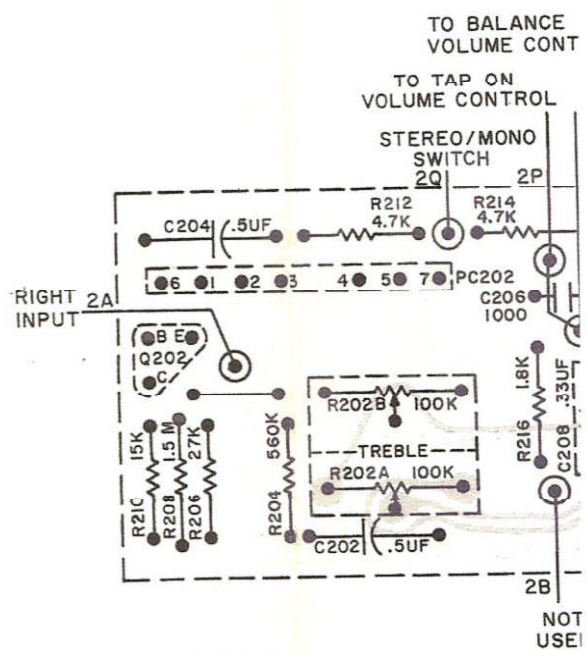

RIGHT CHANNEL
LEFT CHANNEL

1499-1, -2 TONE CONTROL AMPLIFIER

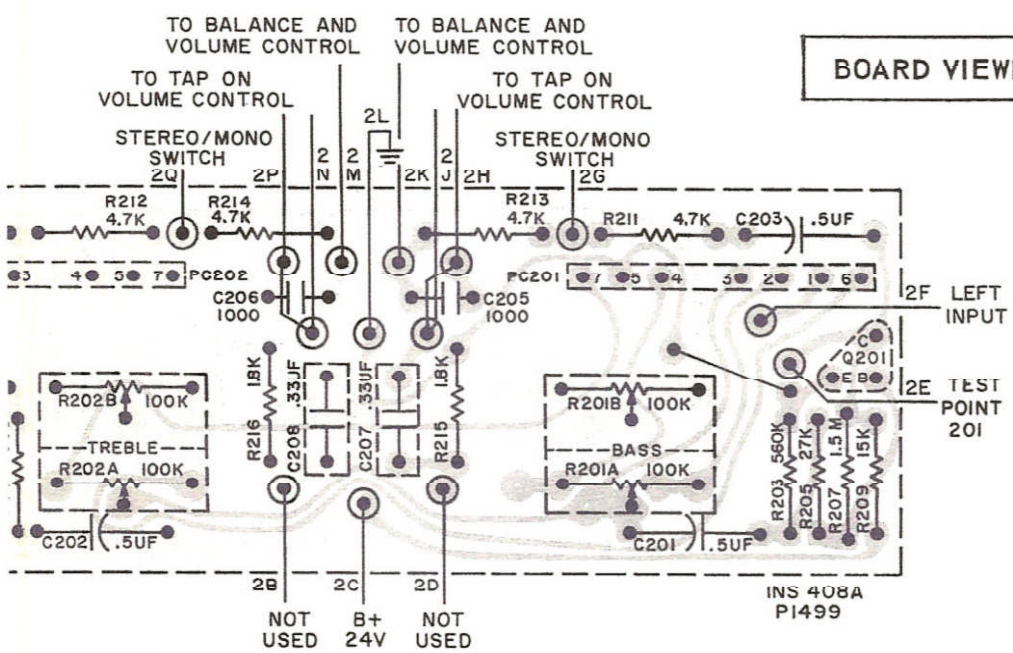
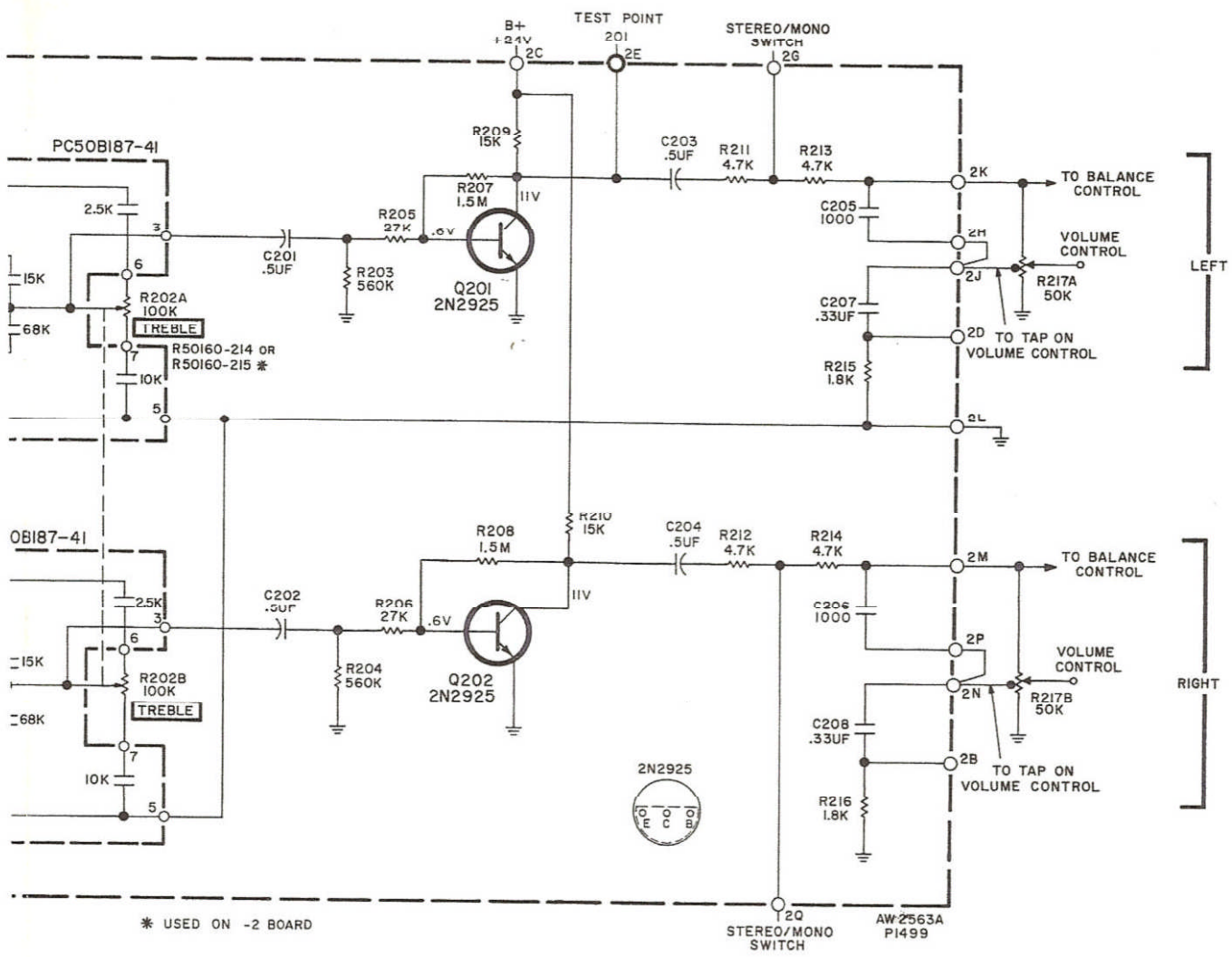

BOARD VIEWED FROM THE COMPONENT SIDE

RIGHT CHANNEL
LEFT CHANNEL

MAIN CHASSIS

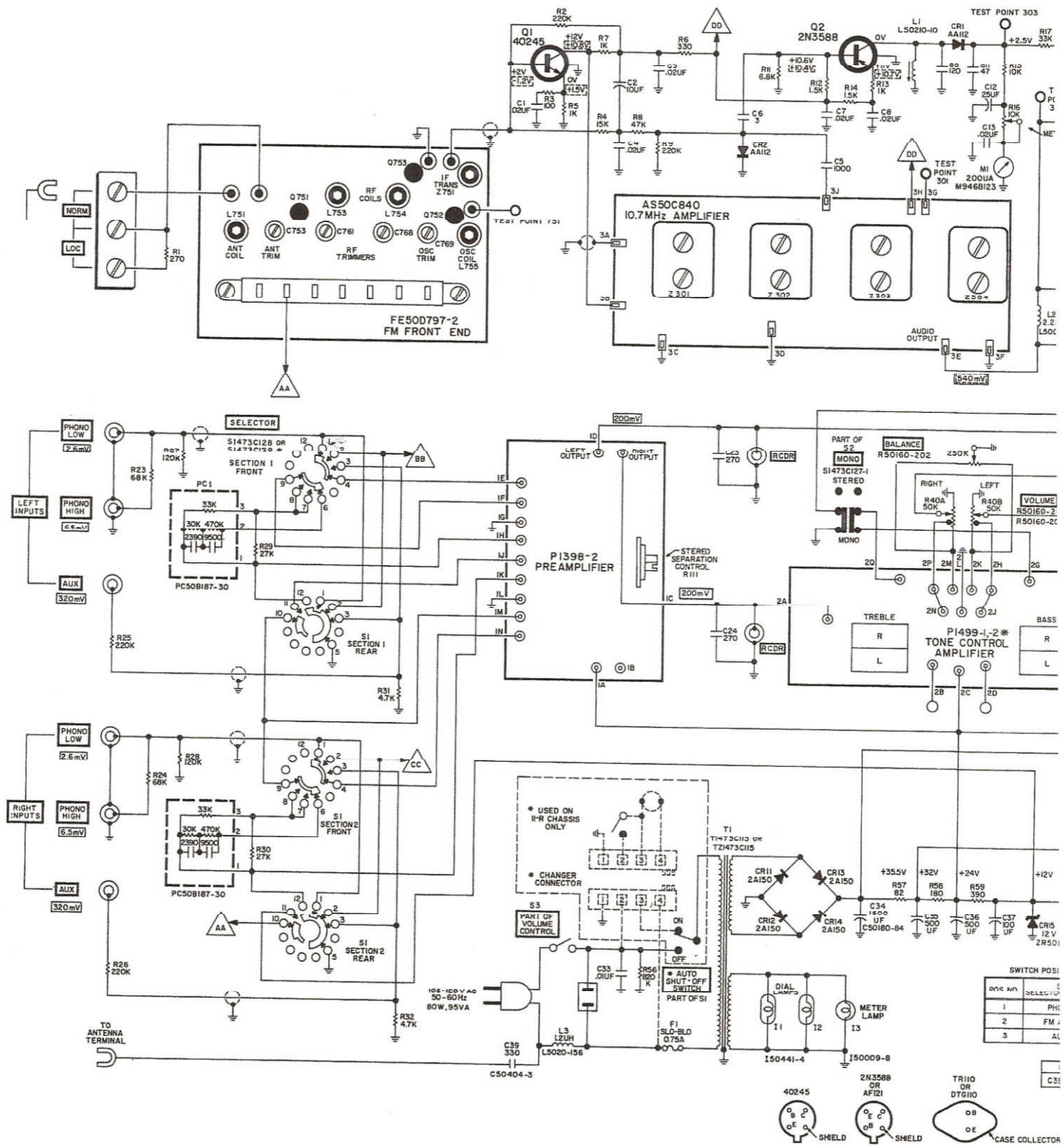

SWITCH POS.	PHONO	ANTENNA	SELECTOR
1	PH		
2	FM		
3	AL		

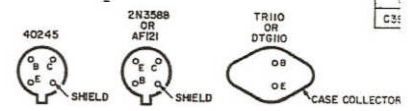

CHASSIS

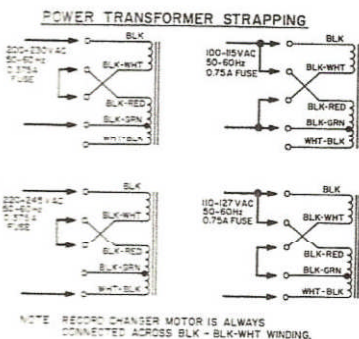
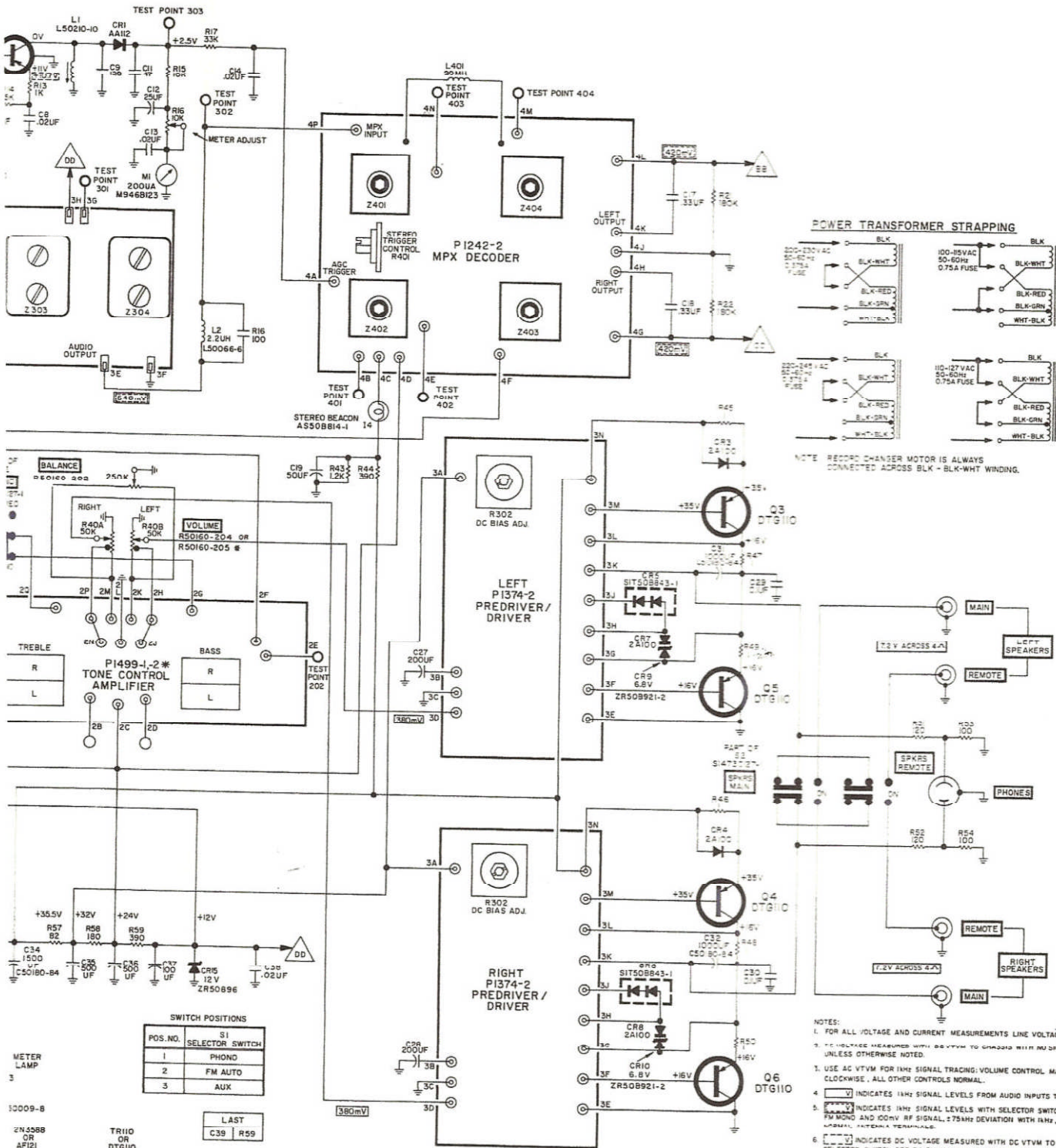

SWITCH POSITIONS

POS. NO.	S1 SELECTOR SWITCH
1	PHONO
2	FM AUTO
3	AUX

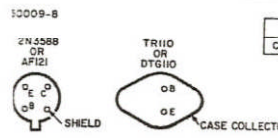

- NOTES:
- FOR ALL VOLTAGE AND CURRENT MEASUREMENTS LINE VOLTAGE = 117VAC
 - VOLTAGE MEASURED WITH 200 OHM TO CHASSIS WITH SIGNAL INPUT, UNLESS OTHERWISE NOTED
 - USE AC VTVM FOR IHz SIGNAL TRACING; VOLUME CONTROL MAXIMUM CLOCKWISE, ALL OTHER CONTROLS NORMAL.
 - V INDICATES IHz SIGNAL LEVELS FROM AUDIO INPUTS TO 4Ω SPEAKER
 - V INDICATES IHz SIGNAL LEVELS WITH SELECTOR SWITCH SET TO FM MOD AND 100mV RF SIGNAL, 2.75MHz DEVIATION WITH IHz, PRESENT AT NORMAL ANTENNA TERMINALS.
 - V INDICATES DC VOLTAGE MEASURED WITH DC VTVM TO CHASSIS WITH SELECTOR SWITCH SET TO FM MOD AND 100mV RF SIGNAL, UNMODULATED PRESENT AT NORMAL ANTENNA TERMINALS.
 - FISHER PART NUMBER LISTED FOR PARTS SPECIALLY SELECTED BY FISHER RADIO CORPORATION.

AW 2571

COMPONENT CONNECTIONS

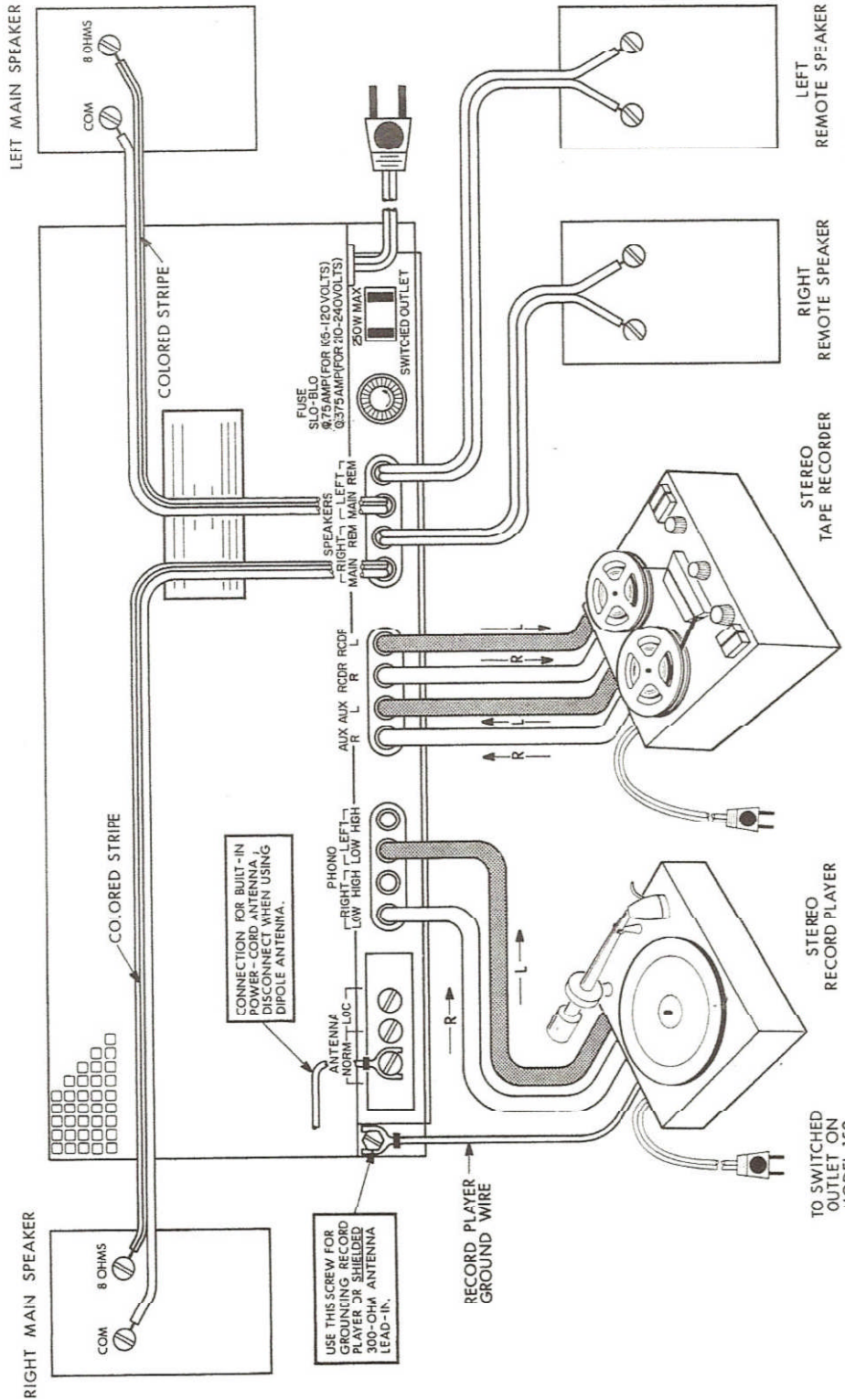

CHASSIS LAYOUT

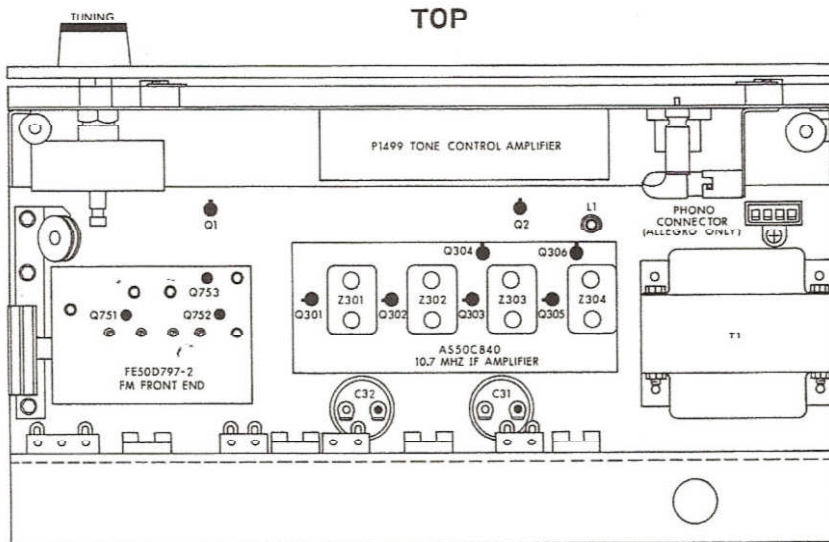

INS 418

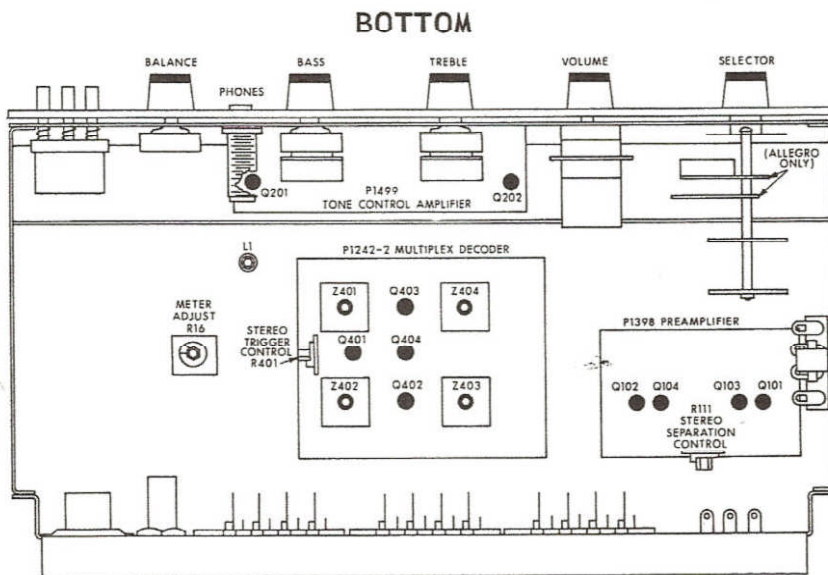

INS 419

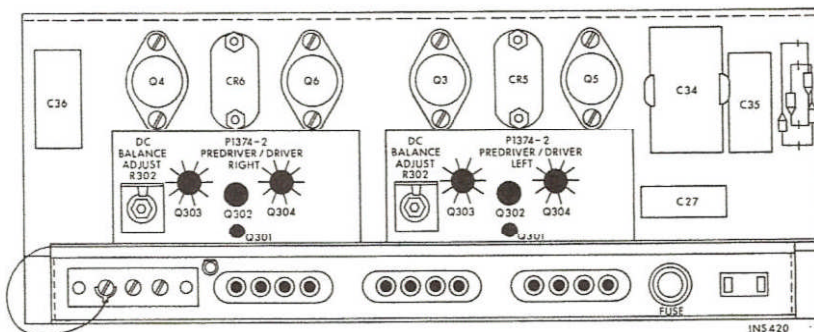

INS 420

REAR



FISHER RADIO CORPORATION • NEW YORK