

This Manual Also Covers
Model 23R Console Chassis

Service Manual

THE FISHER.

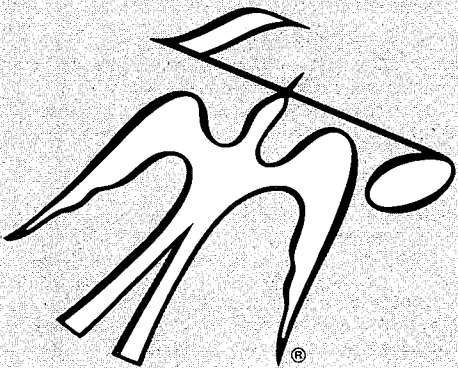
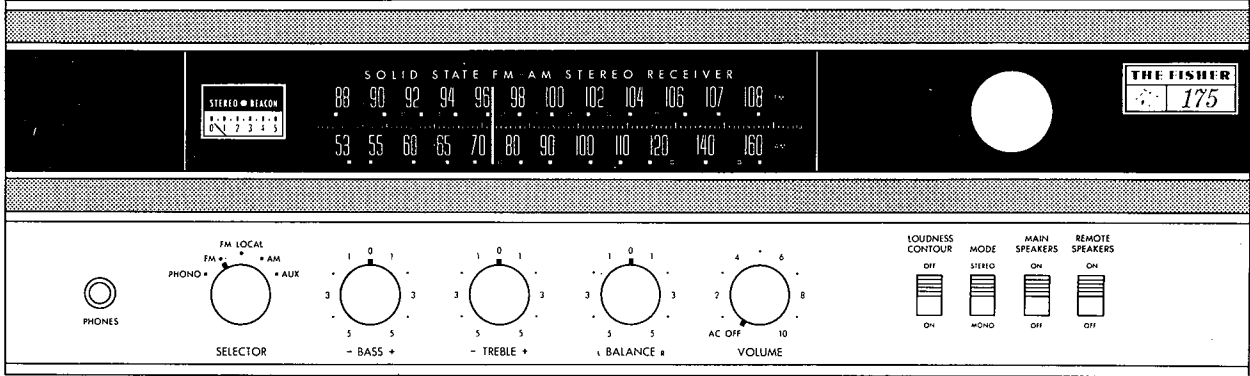

175-T™

CHASSIS SERIAL NUMBERS
BEGINNING 10001

PRICE \$1.00

CAUTION: This is a FISHER precision high-fidelity instrument. It should be serviced only by qualified personnel — trained in the repair of transistor equipment and printed circuitry.

TEST EQUIPMENT REQUIRED

The following are needed to completely test and align modern high-fidelity instruments such as amplifiers, tuners and receivers.

Vacuum-Tube Voltohmmeter (100-mV DC scale)	10.7-MHz Sweep Generator
Audio Vacuum-Tube Voltmeter (10-mV AC scale)	455-kHz Sweep Generator
Oscilloscope (Flat to 100 kHz Minimum)	Line Voltage Autotransformer or Voltage Regulator
Audio (Sine-Wave) Generator	2 — Load Resistors, 4 or 8 Ohm, 50 Watt
Intermodulation Distortion Analyzer	2 — Full Range Speakers for Listening Tests
Harmonic Distortion Analyzer	Stereo Source — Turntable or Tape Recorder for Listening Tests
AM/FM Signal Generator	Soldering Iron with Small Tip Fully Insulated from Power Line
Multiplex Generator (preferably with RF output — FISHER Model 300 or equal)	Suction Desoldering Tool

PRECAUTIONS

Many of these items are included just as a reminder—they are normal procedures for experienced technicians. Short-cuts can be taken but often they cause additional damage — to transistors, circuit components or the printed-circuit board.

Soldering—A well-tinned, hot, clean soldering iron tip will make it easier to solder without damage to the printed-circuit board or the many circuit components mounted on it. It is not the wattage of the iron that counts — it is the heat available at the tip. Some 50-watt irons reach temperatures of 1,000° F — others will hardly melt solder. Small-diameter tips should be used for single solder connections — larger pyramid and chisel tips are needed for larger areas.

- When removing defective resistors, capacitors, etc., the leads should be cut as close to the body of the circuit component as possible. (If the part is not being returned for in-warranty factory replacement it may be cut in half — with diagonal-cutting pliers — to make removal easier.)
- Special de-soldering tips are made for unsoldering multiple-terminal units like IF transformers and electrolytic capacitors. By unsoldering all terminals at the same time the part can be removed with little chance of breaking the printed-circuit board.
- Always disconnect the chassis from the power line when soldering. Turning the power switch OFF is not enough. Power-line leakage paths, through the heating element, can destroy transistors.

Transistors—Never attempt to do any work on the transistor amplifiers without first disconnecting the AC linecord and waiting until the power supply filter-capacitors have discharged.

- Guard against shorts — it takes only an instant for a base-to-collector short to destroy that transistor and possibly others direct-coupled to it. [In the time it takes for a dropped machine screw, washer or even the screwdriver, to glance off a pair of socket terminals (or between a terminal and the chassis) a transistor can be ruined.]
- DO NOT bias the base of any transistor to, or near, the same voltage applied to its collector.
- DO NOT use an ohmmeter for testing transistors. The voltage applied through the test probes may be higher than the base-emitter breakdown voltage of the transistor.

Output Stage and Driver — Replacements for output and

driver transistors, if necessary, must be made from the same beta group as the original type. The beta group is indicated by a colored dot on the mounting flange of the transistor. Be sure to include this information, when ordering replacement transistors.

- If one output transistor burns out (open or shorts), always remove ALL output transistors in that channel and check the bias adjustment, the control and other parts in the network with an ohmmeter before inserting a new transistor. All output transistors in one channel will be destroyed if the base-biasing circuit is open on the emitter end.
- When mounting a replacement power transistor be sure the bottom of the flange, the mica insulator and the surface of the heat sink are free of foreign matter. Dust and grit can prevent perfect contact reducing heat transfer to the heat sink. Metallic particles can puncture the insulator and cause shorts — ruining the transistor.
- Silicone grease must be used between the transistor and the mica insulator and between the mica and the heat sink for best heat conduction. (Use Dow-Corning DC-3 or C20194 or equivalent compounds made for power transistor heat conduction.)
- Use care when making connections to speakers and output terminals. Any frayed wire ends can cause shorts that may burn out the output transistors — they are direct-coupled to the speakers. To reduce the possibility of shorts at the speakers, lugs should be used on the exposed ends or at least the ends of the stranded wires should be tinned to prevent frayed wire ends. The current in the speakers and output circuitry is quite high. Poor contacts or small size wire can cause power losses in the speaker system. Use 14 or 16 AWG for long runs of speaker wiring.

Voltage Measurements—Voltage measurements are made with the line voltage adjusted to 117 volts and all readings are $\pm 10\%$. All voltages are DC, measured with a VTVM to ground, with no signal input unless otherwise noted. indicates 1-kHz audio voltages, measured with an audio AC VTVM to ground at various points from the phono input to the power amplifier output.

Alignment Procedures — Replacement of transistors and components in the front end, IF amplifier and multiplex decoder will normally not require realignment of these circuits. Realignment of these circuits, unless absolutely necessary, is not recommended. Do not attempt a realignment unless the required test equipment is available and the alignment procedure is thoroughly understood.

BECAUSE ITS PRODUCTS ARE SUBJECT TO CONTINUOUS IMPROVEMENT, FISHER RADIO CORPORATION RESERVES THE RIGHT TO MODIFY ANY DESIGN OR SPECIFICATION WITHOUT NOTICE AND WITHOUT INCURRING ANY OBLIGATION.

SERVICE PROCEDURES

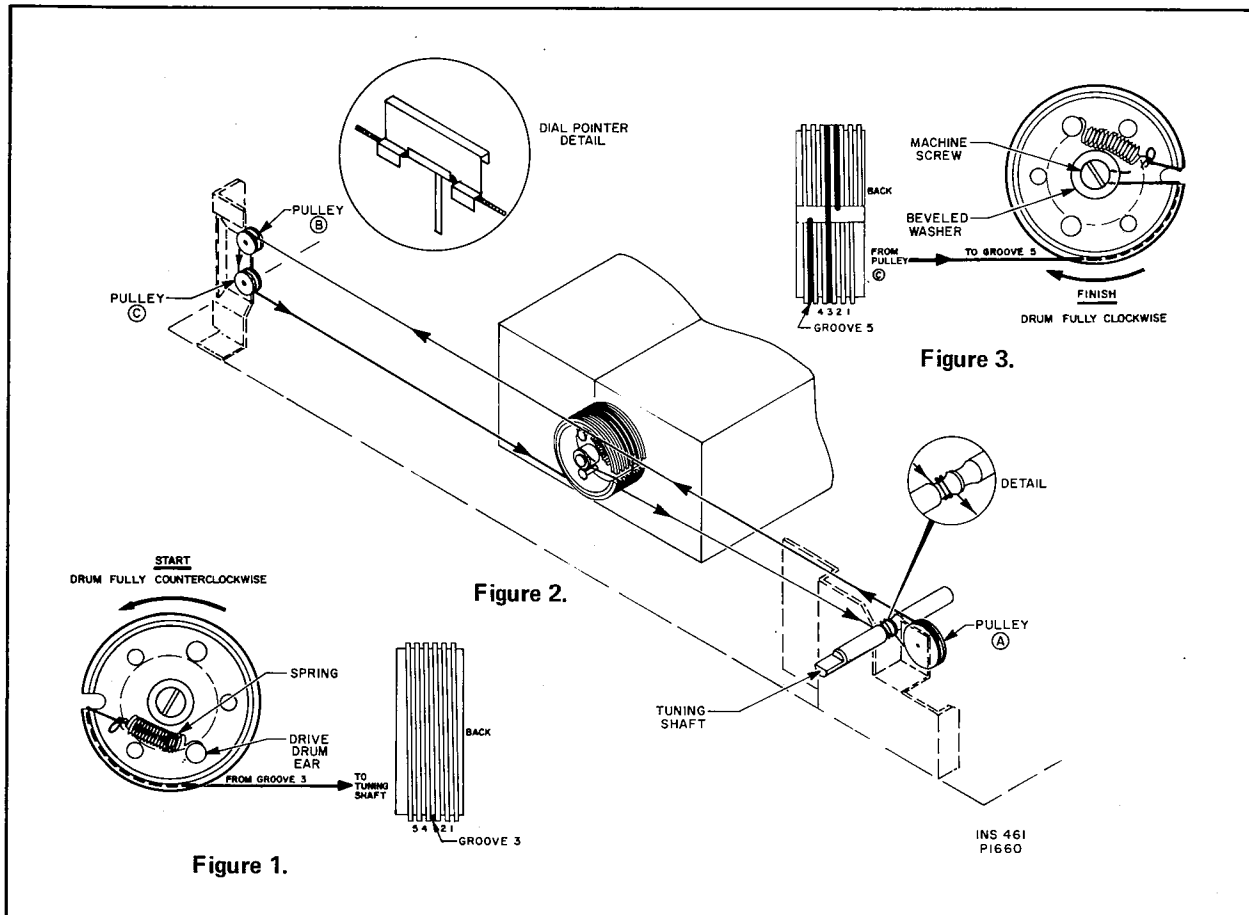

DIAL STRINGING

- (1) Disconnect AC power cord.
- (2) Remove the screws which hold the top cover to the chassis and heat sink and lift off the cover.
- (3) Gently pull all knobs off the front panel control shafts. Remove the hex nuts from the shafts and remove panel by pulling forward over the shafts.
- (4) Remove the dial pointer from the dial cord.
- (5) Gently pull the four leads from the terminal pins on the top rear of the meter and label each wire with its associated pin location for easy replacement later.
- (6) Gently pull the two pairs of dial lamp leads from the terminal pins on the chassis and label each lead.
- (7) Gently pull the pair of meter leads from the terminal pins on the chassis and label.
- NOTE:** These ten push-on terminal leads which connect the dial glass panel to the chassis must be disconnected in order to remove the dial glass panel.
- (8) Remove the screws holding the dial glass panel and remove the panel with the dial glass, pilot lamps, and meter attached.
- (9) Rotate the tuning capacitor drive-drum to its maximum CCW position. Loosen the machine screw in the center of the drive-drum.
- (10) Tie end of dial cord to one end of START spring. Fasten spring to bottom right ear inside drive-drum. See Figure 1.
- (11) Run the dial cord through the slot in the rim of the drive-drum and set in the underside of groove 3.

- (12) Pull dial cord taut and wrap 2 turns CCW around tuning shaft. See Figure 2.
- (13) Guide the dial cord under and around pulley "A", across to the left side, down and around pulleys "B" and "C". Keep the dial cord taut during this procedure.
- (14) Rotate the drive-drum to its maximum CW position, allowing the cord to wind onto the drive-drum. Keep the dial cord taut during this procedure.
- (15) Guide the dial cord under the drive-drum and into groove 5. Bring the dial cord around groove 5 and into the slot in the drive-drum. See Figure 3.
- (16) With the machine screw loosened, place the cord under the beveled washer, pull the dial cord taut, and tighten the screw.
- (17) Turn the tuning shaft to rotate the drive-drum fully CW and fully CCW to distribute the tensioning along the dial cord. Repeat steps (16) and (17) until the START spring is tensioned.
- (18) Replace the dial glass panel assembly using the four mounting screws removed previously.
- (19) Reconnect the ten leads (removed previously) to their respective terminal pins.
- (20) Place the dial cord over and under the tabs on the rear of the dial pointer, (see detail) and place the pointer on the top of the dial glass panel.
- (21) Turn the tuning shaft fully CCW. Slide dial pointer to zero (0) calibration mark on the logging scale while holding tuning shaft fully CCW. Cement dial pointer to dial cord to prevent slippage. Allow cement to thoroughly dry.
- (22) Replace the top cover and secure with the screws removed previously.
- (23) Replace the front panel and secure with the hex nuts removed previously. Replace the knobs on the control shafts.

SERVICE PROCEDURES

REPLACING DIAL LAMPS

- (1) Disconnect AC power cord.
- (2) Gently pull all knobs off the front panel control shafts. Remove the hex nuts from the shafts and remove panel by pulling forward over the shafts.
- (3) Snap out the defective lamp from the spring slip. Place the new lamp in the socket making sure that the unpainted side of the lamp faces the edge of the dial glass.
- (4) Replace the front panel and secure with the hex nuts removed previously. Replace the knobs on the control shafts.

REPLACING METER

- (1) Disconnect AC power cord.
 - (2) Remove the screws which hold the top cover to the chassis and heat sink and lift off the cover.
 - (3) Gently pull all knobs off the front panel control shafts. Remove the hex nuts from the shafts and remove panel by pulling forward over the shafts.
 - (4) Gently pull the four leads from the terminal pins on the top rear of the meter and label each wire with its associated pin location for easy replacement later.
 - (5) Gently pull the two pairs of dial lamp leads from the terminal pins on the chassis and label each lead.
 - (6) Gently pull the pair of meter leads from the terminal pins on the chassis and label.
- NOTE:** These ten push-on terminal leads which connect the dial glass panel to the chassis must be disconnected in order to remove the dial glass panel.
- (7) Remove the four screws holding the dial glass panel. Remove the panel by tilting out the bottom of the panel and sliding downward. Be careful to avoid deforming the dial pointer.
 - (8) Gently pry the meter off the dial glass panel, and scrape the residual adhesive off the panel.
 - (9) Peel the backing from one side of the replacement adhesive mounting pad (FRC Part No. E51A219), and affix it to the replacement meter. Peel the backing from the remaining side of the adhesive, align the meter face over the dial panel cutout, and firmly press the meter to the back of the dial glass panel.
 - (10) Remount the dial glass panel by carefully sliding upward, allowing the dial pointer to seat on the rail. Secure with the four screws removed previously.
 - (11) Reconnect the ten terminal leads removed previously.
 - (12) Replace the front panel and secure with the hex nuts removed previously. Replace the knobs on the control shafts.
 - (13) Replace the top cover and secure with the screws removed previously.

REPLACING STEREO BEACON AND METER LAMPS

NOTE: The compartmented lamp assembly, mounted on the rear of the meter, contains the meter lamp and the STEREO BEACON lamp, and must be replaced as a complete unit.

- (1) Disconnect AC power cord.
- (2) Remove the screws which hold the top cover to the chassis and heat sink and lift off the cover.
- (3) Gently pull the four wires off the terminal pins on the top rear of the meter. Label each wire with its associated pin location to make replacement easier later.
- (4) Gently unsnap the compartmented lamp assembly from the top rear of the meter.
- (5) Center the replacement lamp assembly between the plastic flanges and press firmly into place.
- (6) Reconnect the four wires to their associated terminal pins on the replacement lamp assembly.
- (7) Replace the top cover on the chassis and secure with the screws removed previously.

CLEANING FRONT PANEL

WARNING: Use only plain lukewarm water for moistening a freshly laundered, soft lint-free cloth to clean the front control panel.

REMOVING P.C. BOARDS

To remove a board from its nylon mounts, squeeze the loop of each mounting clip (using pliers), and lift each corner of the board. To remount the board, align the mounting holes over the clips, and press firmly.

SERVICING INTEGRATED CIRCUITS

Integrated Circuits are used in this unit to approach the theoretical maximum of AM suppression and noise limiting. These IC's contain the equivalent of many circuit parts, including transistors, diodes, resistors, and capacitors. These integrated circuits are high-reliability devices, requiring minimum servicing. In the unlikely event that an IC requires servicing, it should be serviced in the same way as a transistor. The preferred troubleshooting procedure is to first isolate the trouble to one stage using AC signal tracing methods. Once the suspected stage is located, the integrated circuit can be checked by measuring the DC voltages at the input and output leads of the IC using a DC VTVM. These DC voltages are the most accurate indications of the operating conditions of the integrated circuit.

WARNING: Do not use an ohmmeter to check continuity with the IC mounted on the printed circuit board. Forward biasing the internal junctions within the IC may burn out the transistors.

When replacing an integrated circuit, the following precautions should be observed:

- (1) Do not replace a defective IC until the cause of the trouble is found. All external resistors, capacitors, and transformers should be checked first to prevent the replacement integrated circuit from failing immediately due to a trouble in the connecting components.
- (2) Solder and unsolder each lead separately using a pliers or other heat sink on the lead to prevent damage from excessive heat.
- (3) Check that the leads of the replacement IC are connected to the correct locations on the printed circuit board before turning the set on.

SERVICE PROCEDURES

POWER AMPLIFIER CENTER VOLTAGE TEST

Turn VOLUME control to minimum. Turn MAIN SPEAKERS switch to ON.

- (1) Connect an 8-ohm load resistor across the LEFT SPKRS MAIN terminals and an 8-ohm load resistor across the RIGHT SPKRS MAIN terminals.
- (2) Connect two 10 k \pm 1% resistors in series across capacitor C6 (2000 μ F). Connect the common lead of a DC VTVM to the junction of the two resistors.
- (3) Connect the probe of the DC VTVM to Test Point 8S (junction of R835 and R837) on left channel of dual-channel power amplifier module. Meter should read 0 volt (\pm 1.5 volts).
- (4) Connect the probe of the DC VTVM to Test Point 8DD (junction of R836 and R838) on right channel of dual-channel power amplifier module. Meter should read 0 volt (\pm 1.5 volts).
- (5) Disconnect the two 10k resistors.

POWER AMPLIFIER IDLING CURRENT ADJUSTMENT

NOTE: Power amplifier center voltage test should be performed before starting the following procedure.

Turn VOLUME control to minimum.

- (1) Connect DC VTVM across resistor R835 (0.47-ohm) on left channel of dual-channel power amplifier module. Meter should read between 15 mV and 35 mV.
- (2) If necessary, adjust R825 (OUTPUT BIAS ADJUST) pot. on predriver/driver board for reading between 15 mV and 35 mV on DC VTVM. Optimum amplifier performance will be achieved with 15 mV setting.
- (3) Connect DC VTVM across resistor R836 on right channel of dual-channel power amplifier module. Meter should read between 15 mV and 35 mV.
- (4) If necessary, adjust R826 pot. on predriver/driver board for reading between 15 mV and 35 mV on DC VTVM.

POWER OUTPUT MEASUREMENT

The output amplifier of this unit is designed to deliver its full-rated power with program material (voice or music) into 8-ohm loads for an indefinite period of time. When a constant audio tone is used as a signal to measure the continuous RMS power output, the following precautions must be taken:

- (1) Measure the power output of one channel at a time.
- (2) Limit the measurement period to 10 minutes with a load resistance of 8 ohms.
- (3) A load resistor with at least a 50-watt rating must be used.

WARNING: If the power output of both channels is measured simultaneously, use a load of 8 ohms per channel and limit measurements to a period not longer than 5 minutes.

HARMONIC DISTORTION TEST

Set BALANCE, BASS, and TREBLE controls to their center positions. Set SELECTOR switch to AUX, LOUDNESS CONTOUR switch to OFF, MODE switch to STEREO, and MAIN SPEAKERS switch to ON. Unplug AC power cord.

- (1) Connect an 8-ohm, 50-watt resistor across the LEFT SPKRS MAIN terminals. In parallel with the load resistor, connect the input leads of an HD analyzer and the input leads of an accurately calibrated AC VTVM.
- (2) Connect a low-distortion audio sine-wave generator, set for 1,000 Hz, to the Left channel AUX input.
- (3) Connect AC power cord and rotate VOLUME control to maximum.
- (4) Increase audio generator level for 20 watts output (12.6 V RMS across 8-ohm load). HD meter should read 0.5% or less.
- (5) Repeat preceding steps for right channel.

INTERMODULATION DISTORTION TEST

NOTE: Bypass C7 and C8 with direct connections for IM test on 23R console chassis.

Set BALANCE, BASS and TREBLE controls to their center positions. Set SELECTOR switch to AUX, LOUDNESS CONTOUR switch to OFF, MODE switch to STEREO, and MAIN SPEAKERS switch to ON. Unplug AC power cord.

- (1) Connect an 8-ohm, 50-watt resistor across the LEFT SPKRS MAIN terminals. In parallel with the load resistor, connect the input leads of an IM distortion analyzer and the input leads of an accurately calibrated AC VTVM.
- (2) Connect IM-analyzer generator output to the Left channel AUX input. Set level of IM-analyzer generator for 600 mV output.
- (3) Connect AC power cord and adjust VOLUME control for 20 watts output (10.3 V RMS across 8-ohm load). AFTER ONE FULL MINUTE OF WARM-UP, PROCEED TO NEXT STEP.
- (4) IM meter reading should be 1.0% or less.
- (5) Repeat preceding steps for right channel.

NOTE: If any of the preceding instructions differ from those in the IM-analyzer instruction manual, it is best to follow those in the manual. If a load resistor of 50-watt rating is built into the IM analyzer, a separate load resistor is not required.

FM IF AND DETECTOR ALIGNMENT

Set SELECTOR switch to FM. Turn VOLUME control to minimum.

- (1) Disconnect the jumper lead from FM Test Point 301 (pin 3N on AM/FM IF, MPX board) and connect vertical input of scope to Test Point 301. Connect ground lead of scope to pin 3G.
- (2) Connect an 82k resistor across scope input and set scope vertical sensitivity to approximately 100mV/cm.

SERVICE PROCEDURES

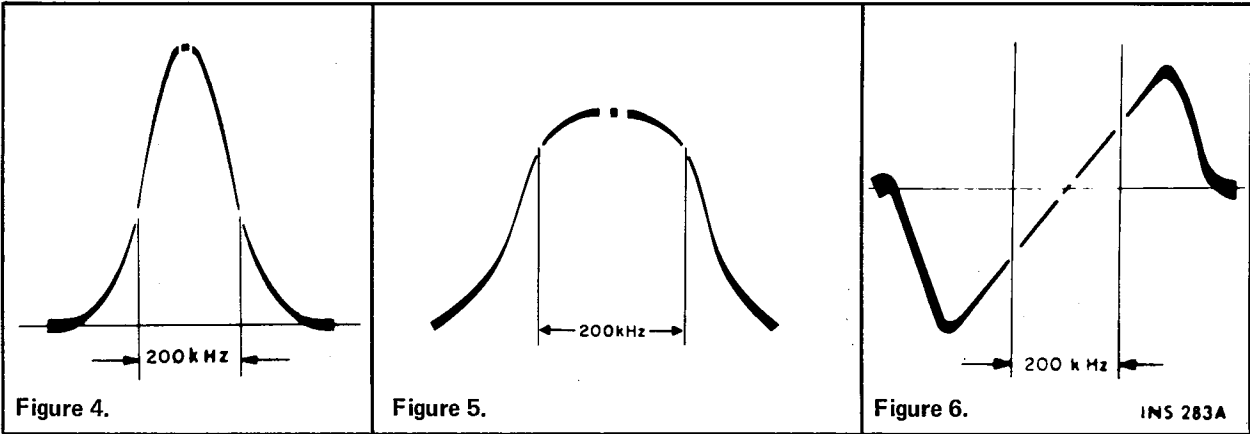

- (3) Connect 10.7 MHz sweep generator to Test Point 501 (pin 5F on FM RF board). Connect ground lead of generator to pin 5G. Adjust generator level and sweep to observe IF response curve.
- (4) Adjust top and bottom cores of Z305, Z304, and Z302 (on AM/FM IF, MPX board) for symmetry and maximum gain.
- (5) Adjust top and bottom cores of L505 (on FM RF board) for maximum gain and symmetry. Repeat alignment until maximum gain and symmetry are obtained (see Figure 4).
- (6) Increase generator level to full output (approximately 100,000 μ V). If necessary, slightly readjust top core of Z305 to center 10.7 MHz marker (see Figure 5).
- (7) Reconnect the jumper lead to FM Test Point 301 (pin 3N on AM/FM IF, MPX board) removed previously. Disconnect the 82k resistor across scope input connected previously.
- (8) Reduce generator sweep to zero (sweep off). Adjust FM METER ADJ. pot. R328 (on AM/FM IF, MPX board) for front panel tuning meter reading of 4.5.
- (9) Connect vertical input of scope to Test Point 3M (on AM/FM IF, MPX board). Use same scope sensitivity setting (100mV/cm).
- (10) Adjust generator level and sweep to observe detector "S" curve. Adjust bottom core of Z306 first, then top core for maximum gain and symmetry (see Figure 6).
- (11) Connect DC VTVM to Test Point 3M. Use 1.5 volts DC meter scale or lower.
- (12) Readjust top core of Z306 for zero (0) reading (within ± 0.2 volt) on DC VTVM.

- (2) Connect an FM generator to the FM ANTenna terminals. Use a 120-ohm composition resistor in series with each lead from the generator (see Figure 7).
 - (3) Connect a scope and an AC VTVM to either Left or Right RCDR OUT jack.
 - (4) Set FM generator frequency and TUNING dial pointer to 90 MHz. Modulate generator with 400 Hz, ± 75 kHz deviation. Set generator level as low as possible.
- NOTE:** Use the tuning meter during alignment and adjust the generator level to keep the meter reading between 2 and 3.
- (5) Align (oscillator coil) L504 first, then (mixer coil) L503 and (RF coil) L502 for maximum reading on AC VTVM and tuning meter, and maximum waveform amplitude and symmetry.
 - (6) Set generator frequency and TUNING dial pointer to 106 MHz.
 - (7) Align (oscillator trimmer) C512 first, then (mixer trimmer) C511 and (RF trimmer) C503 for maximum reading on AC VTVM and tuning meter, and maximum waveform amplitude and symmetry.
 - (8) Repeat alignment several times until accurate dial calibration and maximum gain are obtained. Keep the generator output as low as possible during all adjustments.

FM FRONT END ALIGNMENT

NOTE: FM IF alignment must be performed before starting this procedure.

Set SELECTOR switch to FM, and MODE switch to MONO. Turn VOLUME control to minimum.

- (1) Set TUNING dial pointer to zero (0) calibration mark on the logging scale. If the dial pointer is not centered on the 0 at the extreme end of the knob rotation, reposition the pointer assembly on the dial cord and cement the pointer in place to prevent slippage. Allow cement to thoroughly dry.

NOTE: Repositioning the dial pointer may require realignment of AM RF board for correct AM station calibration.

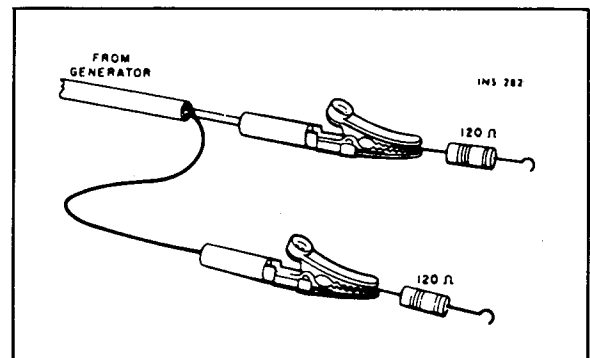

Figure 7. Connections To Provide 300-ohm Generator Output Impedance. Matching Resistors Reduce Generator Voltage By Half At Antenna Terminals.

SERVICE PROCEDURES

TUNING METER CALIBRATION

NOTE: Meter calibration should be performed after FM IF and RF alignment.

Set SELECTOR switch to FM. Turn VOLUME control to minimum.

- (1) Connect an FM generator to the FM ANTenna terminals. Use a 120-ohm composition resistor in series with each lead from the generator (see Figure 7).
- (2) Set generator frequency to same frequency as receiver. Set generator RF output level to full output (approximately 100,000 uV) with audio modulation off.
- (3) Adjust generator frequency for peak tuning meter reading.
- (4) Adjust FM METER ADJ. pot. R328 (on AM/FM IF, MPX board) for tuning meter reading of 4.5.

MULTIPLEX ALIGNMENT

Two methods of aligning the multiplex decoder are given. The preferred procedure uses a multiplex generator with RF and 19 kHz outputs and with 1 kHz modulation, such as the FISHER 300 Multiplex Generator. This is the better method of alignment because the front end and IF stages are also checked through the use of this procedure. An alternate procedure for use with multiplex generators not having an RF output is also given.

PREFERRED ALIGNMENT PROCEDURE

NOTE: Check the alignment of the IF amplifier before aligning the multiplex decoder. Poor IF alignment can make proper MPX adjustment impossible.

Set SELECTOR switch to FM, MODE switch to STEREO, and VOLUME control to minimum.

- (1) Connect RF output of multiplex generator to the FM ANTenna terminals. Use a 120-ohm composition resistor in series with each lead from RF output (see Figure 7). Set MPX generator for external modulation with 19 kHz pilot carrier, ± 7.5 kHz deviation (10% pilot, no audio). Tune receiver to RF frequency of MPX generator.
- (2) Connect DC VTVM to Test Point 403 (pin 4G on AM/FM IF, MPX board).
- (3) Adjust cores of Z401 and Z402 (on AM/FM IF, MPX board) for maximum reading on DC VTVM (2.5 to 4 VDC).
- (4) Connect output of audio generator, set for 1 kHz, to the external modulation input of MPX generator and to external sync input of an oscilloscope. Adjust audio generator level for composite signal ± 75 kHz deviation (10% pilot, 90% audio). Modulate right channel only.
- (5) Connect AC VTVM to Left RC DR OUT jack. Connect scope through voltage divider probe (see Figure 8) to Test Point 402 (pin 4K on AM/FM IF, MPX board).
- (6) Adjust core of Z403 (on AM/FM IF, MPX board) for maximum gain and as straight a base-line as possible on scope (see Figure 9). AC VTVM should read minimum.
- (7) With MPX generator modulated on right channel only, connect AC VTVM to Right RC DR OUT jack. Record reading on AC VTVM.
- (8) Set MPX generator to modulate left channel only. Adjust R107 SEPARATION CONTROL (on preamplifier board) for minimum reading on AC VTVM; at least 30 dB below reading recorded in Step (7). Record reading.

- (9) Connect AC VTVM to Left RC DR OUT jack. Same reading ± 2 dB as recorded in Step (7).
 - (10) Set MPX generator to modulate right channel only. Same reading ± 3 dB as recorded in Step (8).
- NOTE:** If equal readings cannot be obtained in Steps (8) and (10), readjust Z402 slightly (on AM/FM IF, MPX board) and repeat Steps (7) through (10).

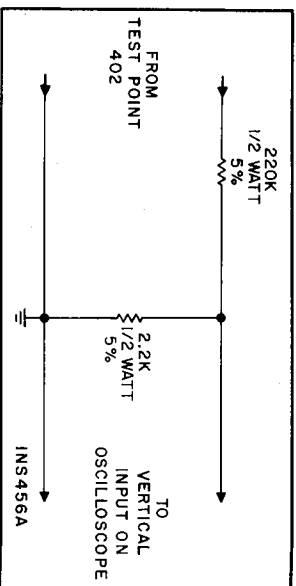

Figure 8. Voltage Divider Probe.

ALTERNATE ALIGNMENT PROCEDURE

Set SELECTOR switch to FM, MODE switch to STEREO, and VOLUME control to minimum.

- (1) Disconnect the jumper lead going to pin 4A (on AM/FM IF, MPX board) and connect the output of the multiplex generator through a 15k resistor to pin 4A.
- (2) Connect DC VTVM to Test Point 403 (on AM/FM IF, MPX board). Connect the vertical input of the scope to pin 4A.
- (3) Set MPX generator for 19 kHz pilot carrier output only. Adjust pilot level for approximately 120 mV peak-to-peak input at pin 4A.
- (4) Adjust cores of Z401 and Z402 (on AM/FM IF, MPX board) for maximum reading on DC VTVM (2.5 to 4 VDC).
- (5) Connect output of audio generator, set for 1 kHz, to the external modulation input of MPX generator and to the external sync input of an oscilloscope. Adjust audio generator level for 1.2 volts peak-to-peak composite MPX input (10% pilot, 90% audio). See Figure 10. Modulate right channel only. Proceed with Steps (5) through (10) of PREFERRED ALIGNMENT PROCEDURE.
- (6) Reconnect the jumper lead going to pin 4A (on AM/FM IF, MPX board) removed previously.

AM IF ALIGNMENT

Set SELECTOR switch to AM, and VOLUME control to minimum.

- (1) Connect 455 kHz sweep generator to pin 7A (on AM RF board). Use a 0.1 uF capacitor in series with the generator lead. Connect generator ground to pin 7C.
- (2) Connect vertical input of scope to Test Point 302 (pin 3Q on AM/FM IF, MPX board). Connect scope ground to pin 3G. Set scope vertical input sensitivity to approximately 200 mV/cm.
- (3) Adjust generator level and sweep to observe IF response curve. Set generator output as low as possible.
- (4) Adjust top and bottom cores of Z303, Z301 (on AM/FM IF, MPX board), and Z701 (on AM RF board) for maximum gain and symmetry. Repeat alignment until maximum gain and symmetry are obtained (see Figure 11).

SERVICE PROCEDURES

CORRECT FOR RIGHT CHANNEL MODULATION

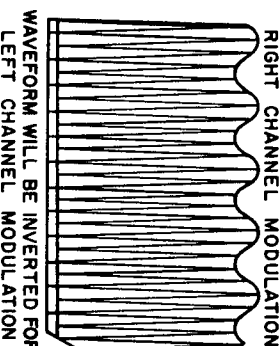

INCORRECT

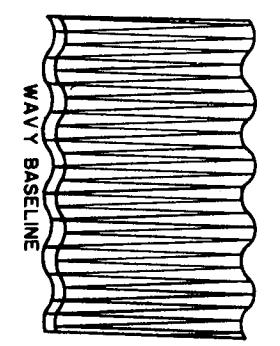

Figure 9. Waveform At Test Point 402.

CORRECT

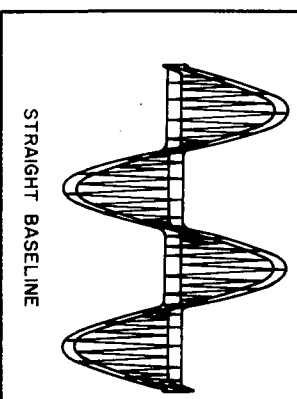

Figure 10. Composite Input To Multiplex Decoder.

NOTE: Repositioning the dial pointer may require realignment FM RF board for correct FM station calibration.

- (2) Open the AM ANTenna GND link at the antenna terminals. Connect an AM generator to the AM ANTenna and GND terminals.
 - (3) Connect a scope and an AC VTVM to either the Left or Right RC DR OUT Jack.
 - (4) Set AM generator frequency and TUNING dial pointer to 600 kHz. Use 30% modulation with 400 Hz. Set generator output as low as possible.
 - (5) Align oscillator coil Z701 (on AM RF board) for maximum reading on AC VTVM and maximum waveform amplitude and symmetry.
 - (6) Set AM generator frequency and TUNING dial pointer to 1400 kHz. Adjust oscillator trimmer C703 (on AM RF board) for maximum reading on AC VTVM and maximum waveform amplitude and symmetry.
 - (7) Repeat alignment several times until accurate dial calibration and maximum gain are obtained. Keep the generator output as low as possible during all adjustments.
 - (8) Reset AM generator frequency and TUNING dial pointer to 600 kHz. Adjust the position of the small coil on the ferrite loop antenna for maximum reading on AC VTVM and maximum waveform amplitude and symmetry.
- NOTE:** To adjust the antenna coil, melt the wax holding the small coil to the end of the ferrite loop antenna. Shift the coil back and forth for maximum audio indication. To secure the coil in position, remelt the wax.
- (9) Reset AM generator frequency and TUNING dial pointer to 1400 kHz. Adjust antenna trimmer C701 (on AM RF board) for maximum reading on AC VTVM and maximum waveform amplitude and symmetry.
 - (10) Repeat steps (8) and (9) several times until maximum gain is obtained. Keep generator output as low as possible during all adjustments.

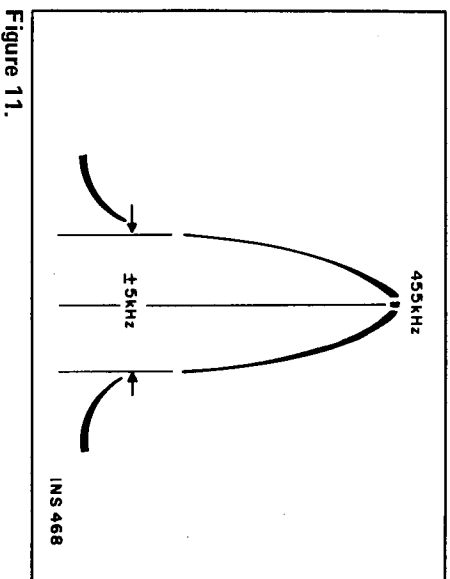

Figure 11.

AM RF ALIGNMENT

NOTE: AM IF alignment must be performed before starting this procedure.

Set SELECTOR switch to AM, and VOLUME control to minimum.

- (1) Set TUNING dial pointer to zero (0) calibration mark on the logging scale. If dial pointer does not coincide with the (0) at the extreme end of knob rotation, reposition the pointer in place to prevent slippage.

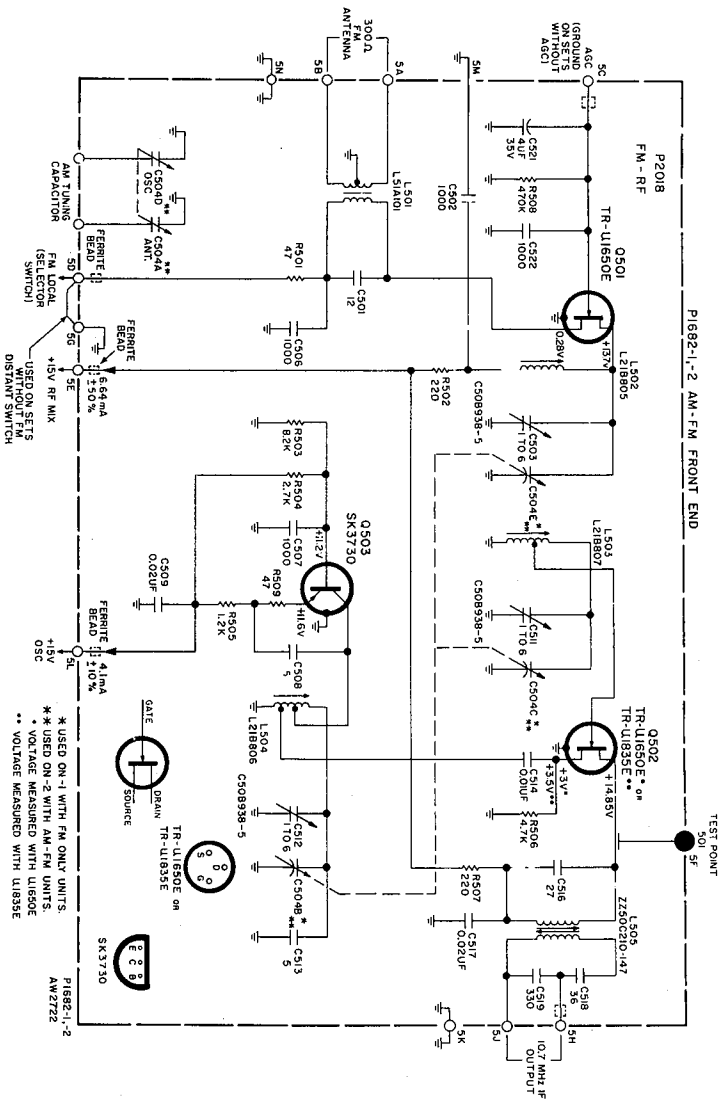

BOARD VIEWED FROM COMPONENT SIDE

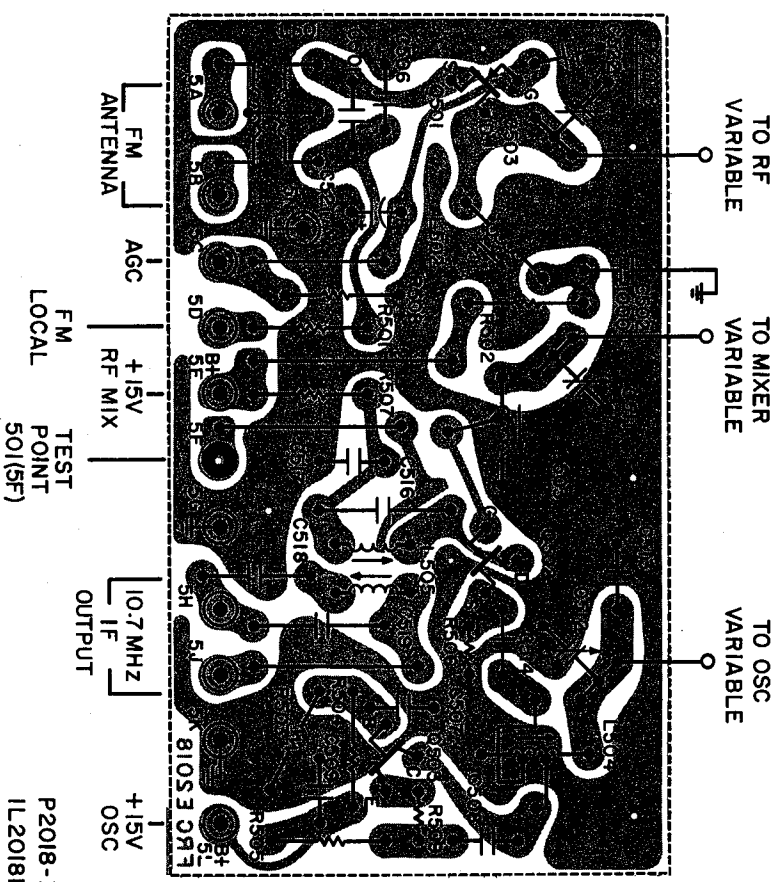

P2018-1
IL2018B111

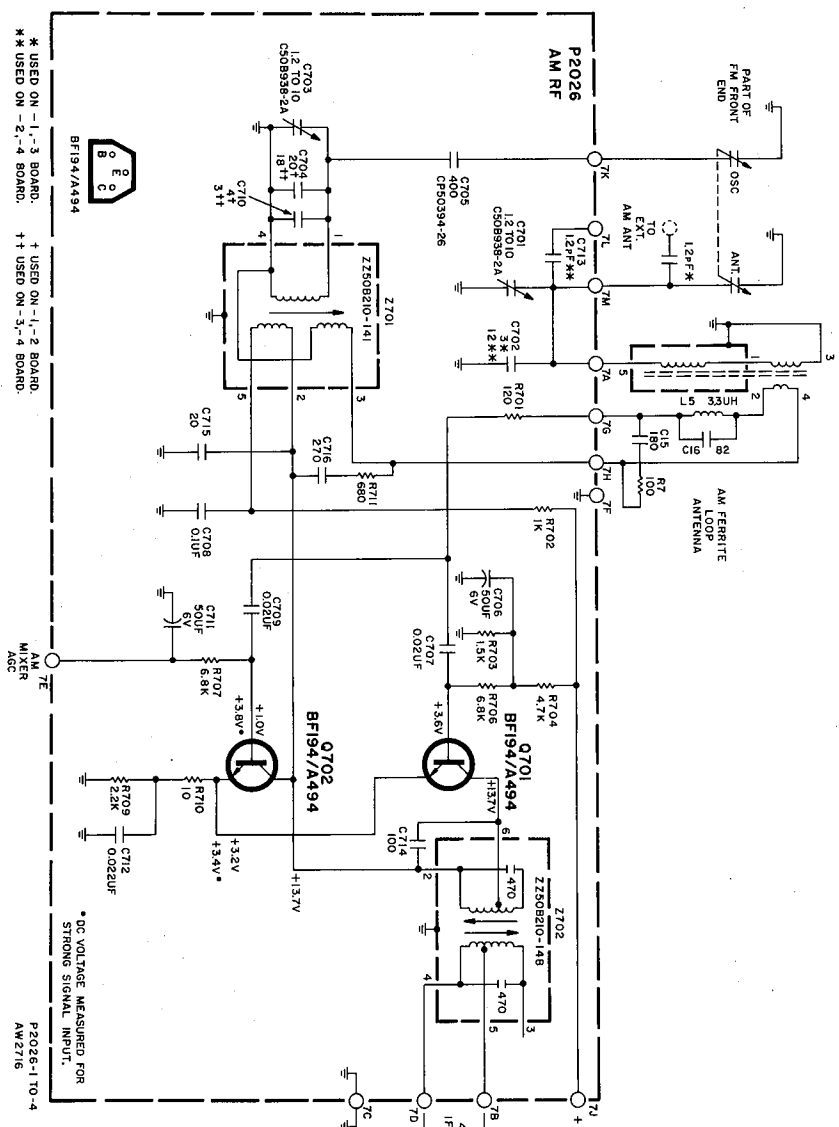

BOARD VIEWED FROM COMPONENT SIDE

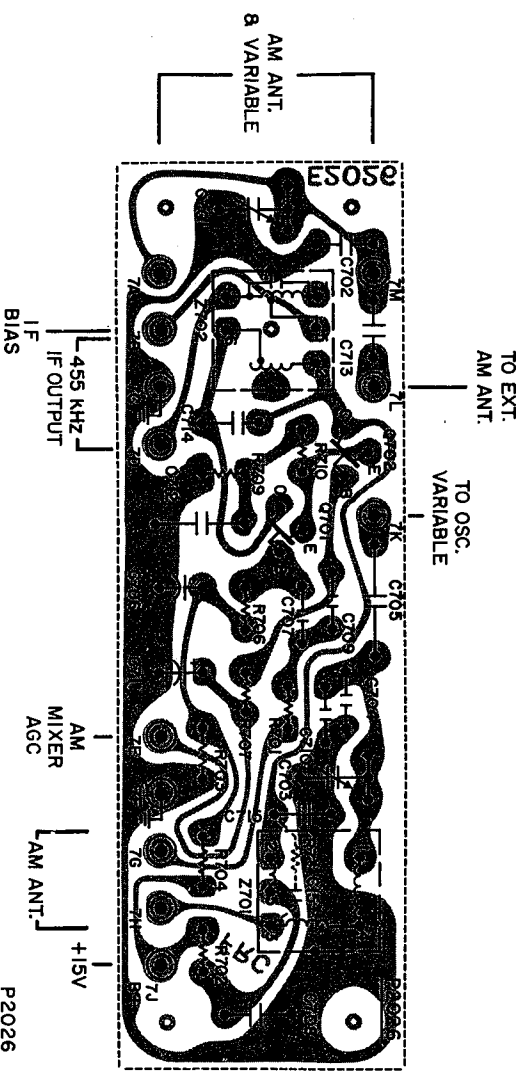

P2026
IL2026B111
* ON UNDERSIDE OF BOARD.

2030-1 POWER SUPPLY

SCHEMATIC SHOWN ON MAIN CHASSIS DIAGRAM

BOARD VIEWED FROM COMPONENT SIDE

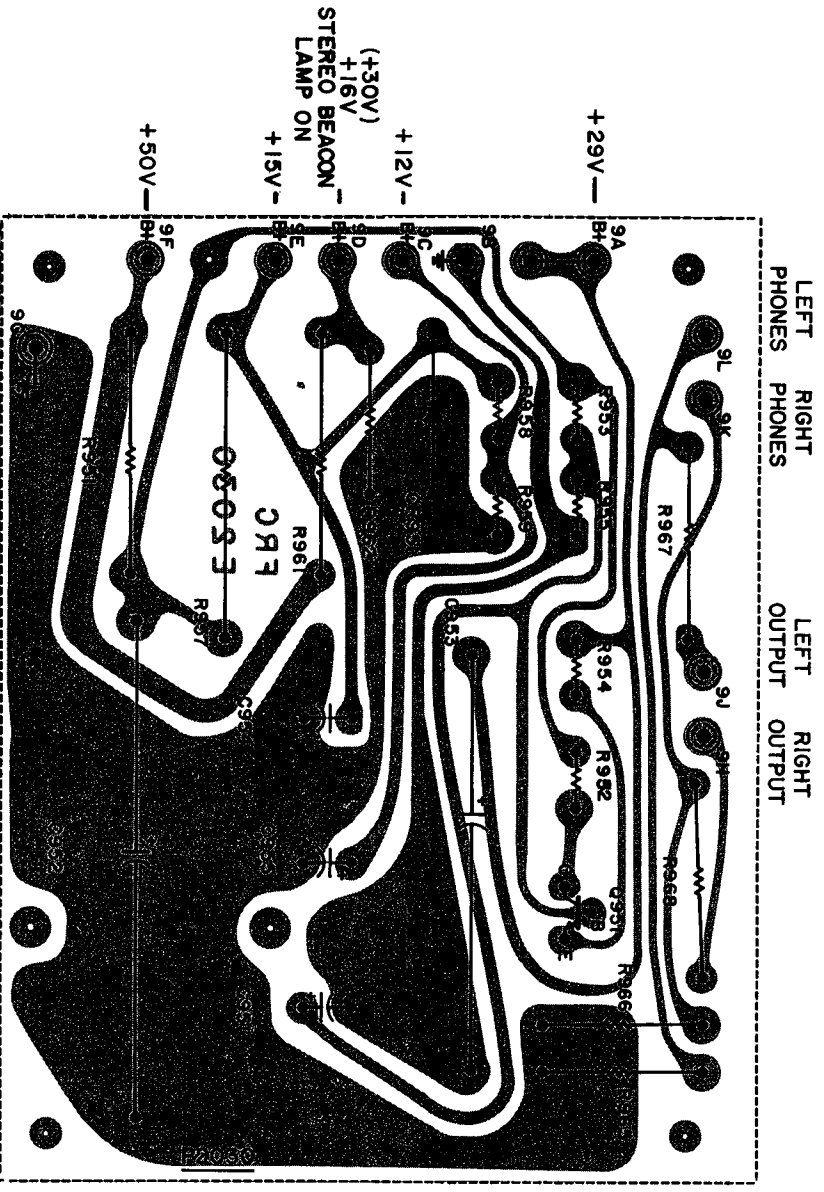

P2030
1L2030B111

CHASSIS LAYOUT

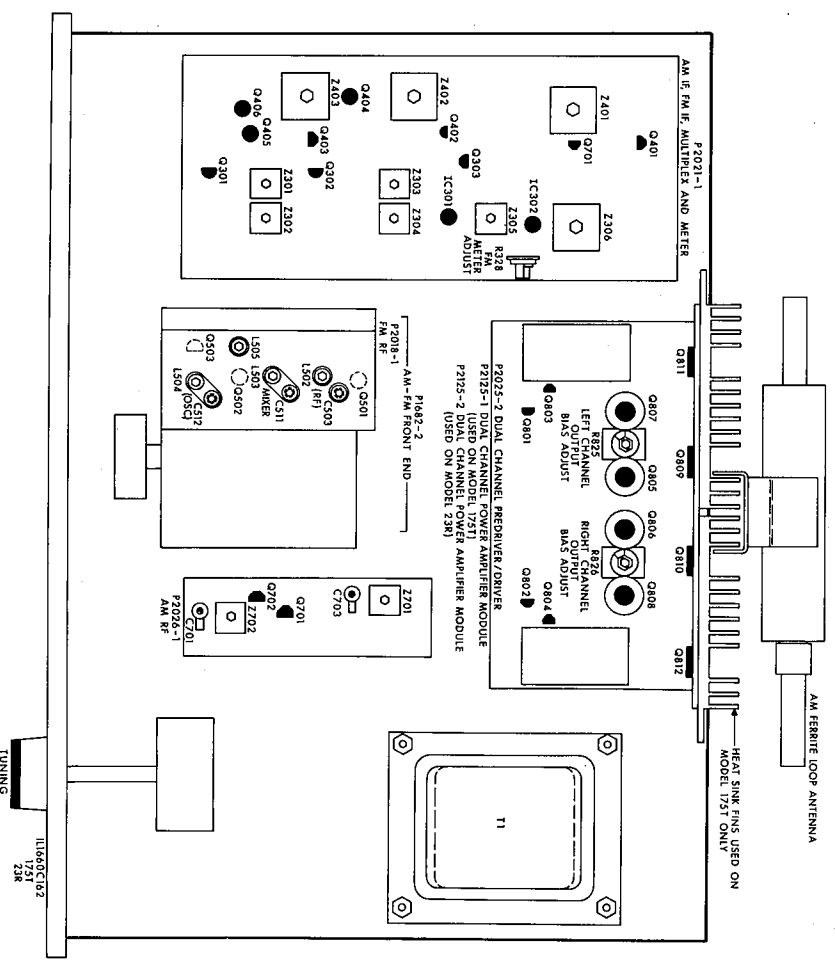

TOP

BOTTOM

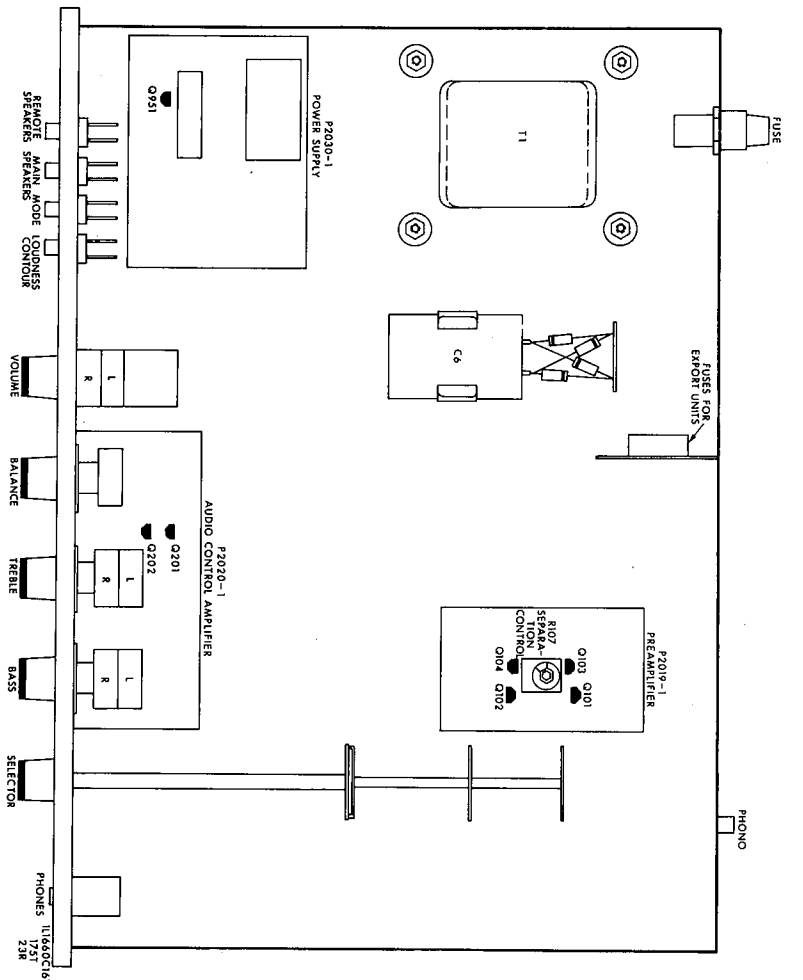

2021-1 AM/FM IF, MPX, METER

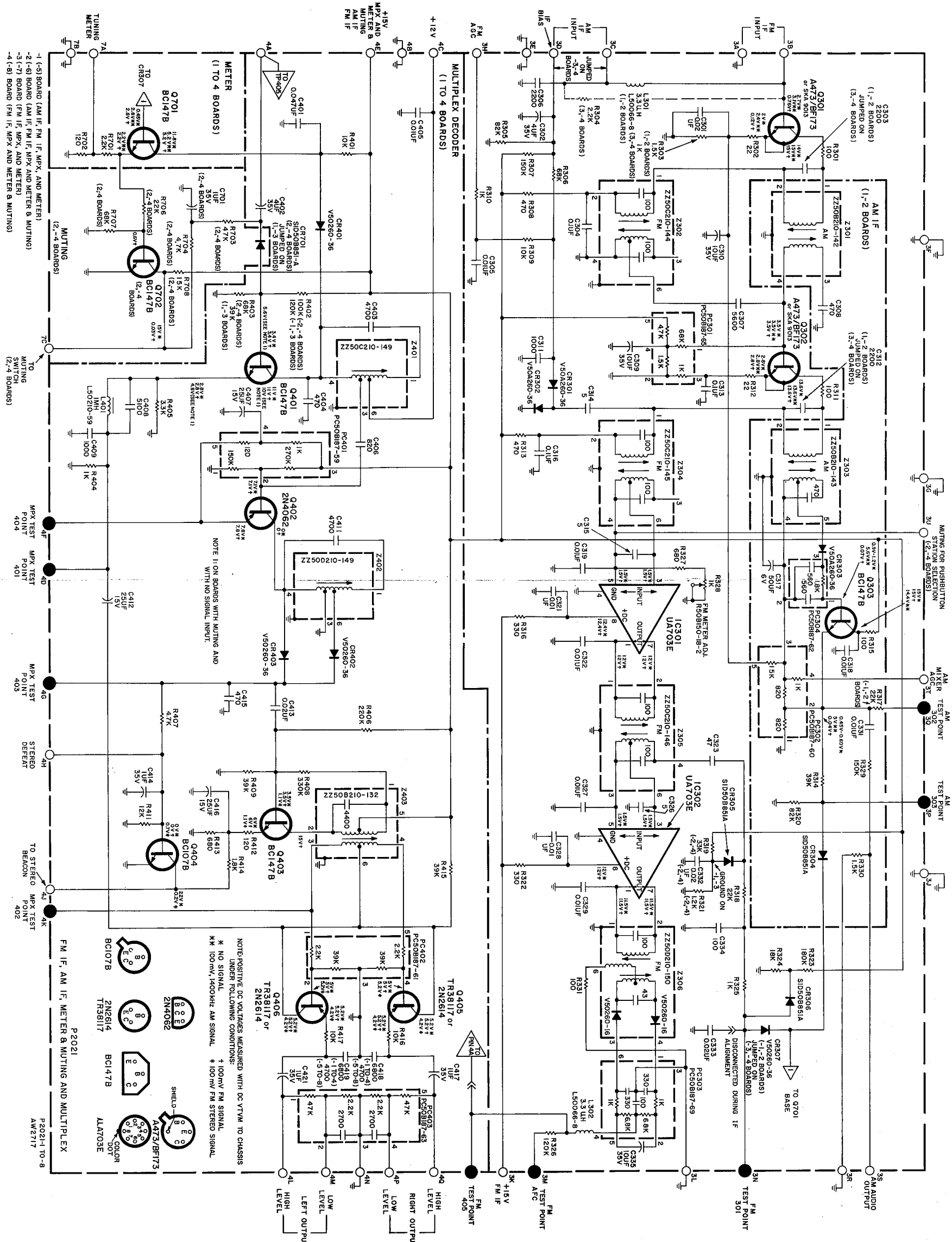

NOTE: POSITIVE DC VOLTAGES MEASURED WITH DC VTM TO CHASSIS UNDER FOLLOWING CONDITIONS:
 * NO SIGNAL
 ** 100mV, 1000kHz AM SIGNAL + 100mV FM STEREO SIGNAL

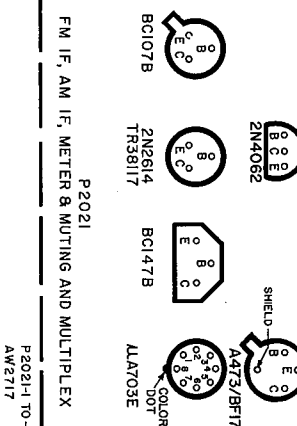

1-(3) BOARD (AM IF, FM IF, MPX, AND METER)
 2-(6) BOARD (AM IF, FM IF, MPX AND METER & MULTIPLEX)
 3-(7) BOARD (AM IF, FM IF, MPX, AND METER)
 4-(8) BOARD (FM IF, MPX AND METER & MULTIPLEX)

2021-1 AM/FM IF, MPX, METER

BOARD VIEWED FROM COMPONENT SIDE

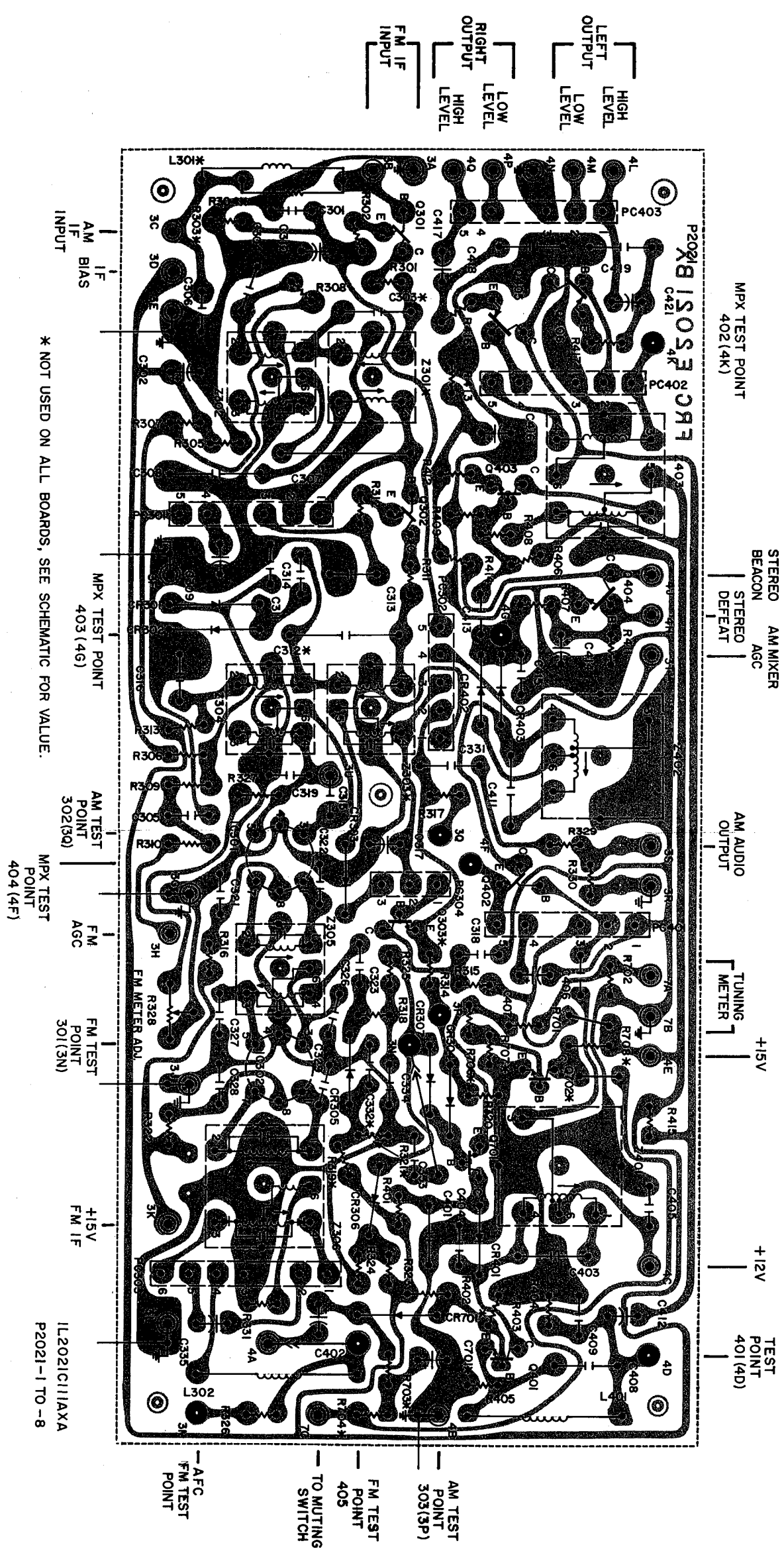

* NOT USED ON ALL BOARDS, SEE SCHEMATIC FOR VALUE.

2019-1 PREAMPLIFIER

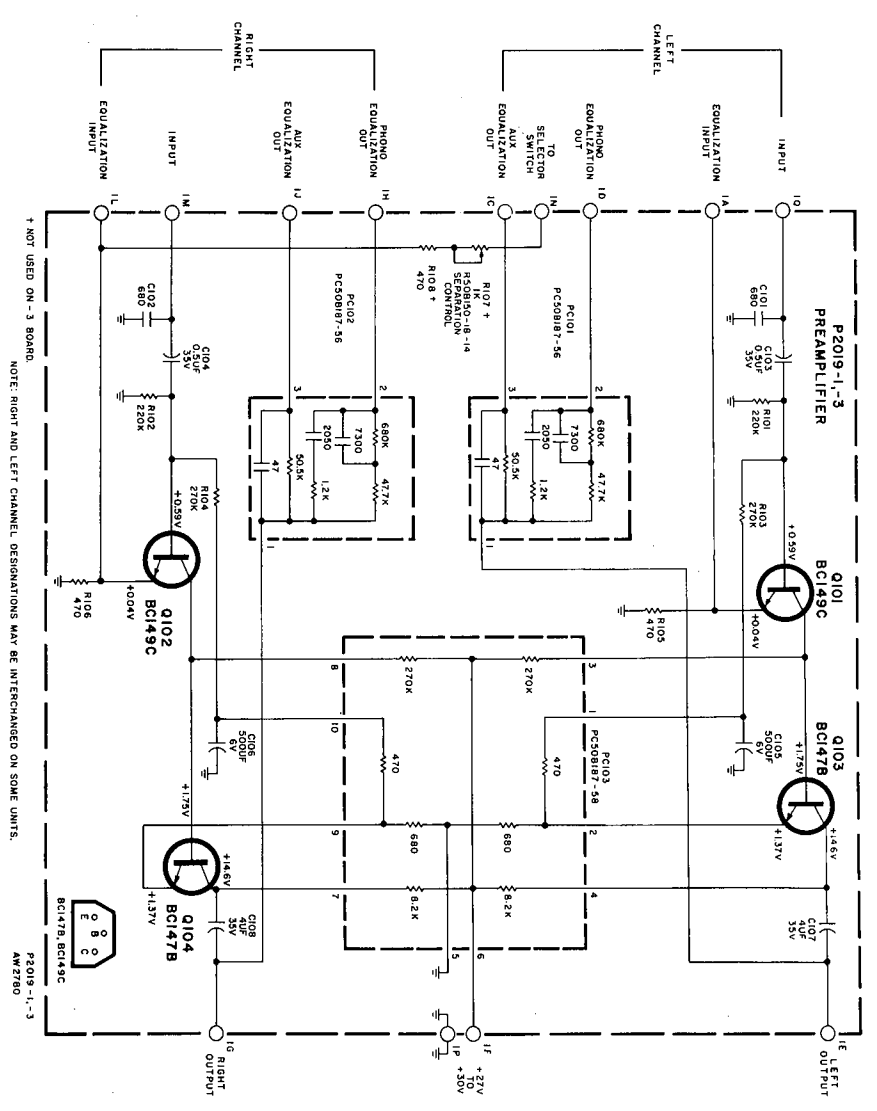

BOARD VIEWED FROM COMPONENT SIDE

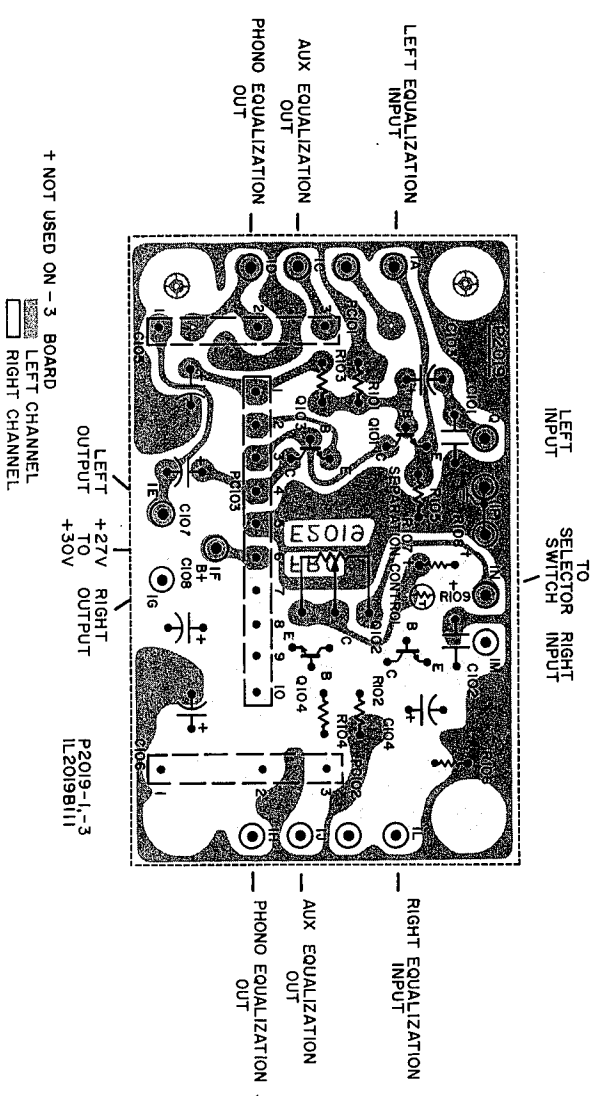

2020-1 AUDIO CONTROL AMPLIFIER

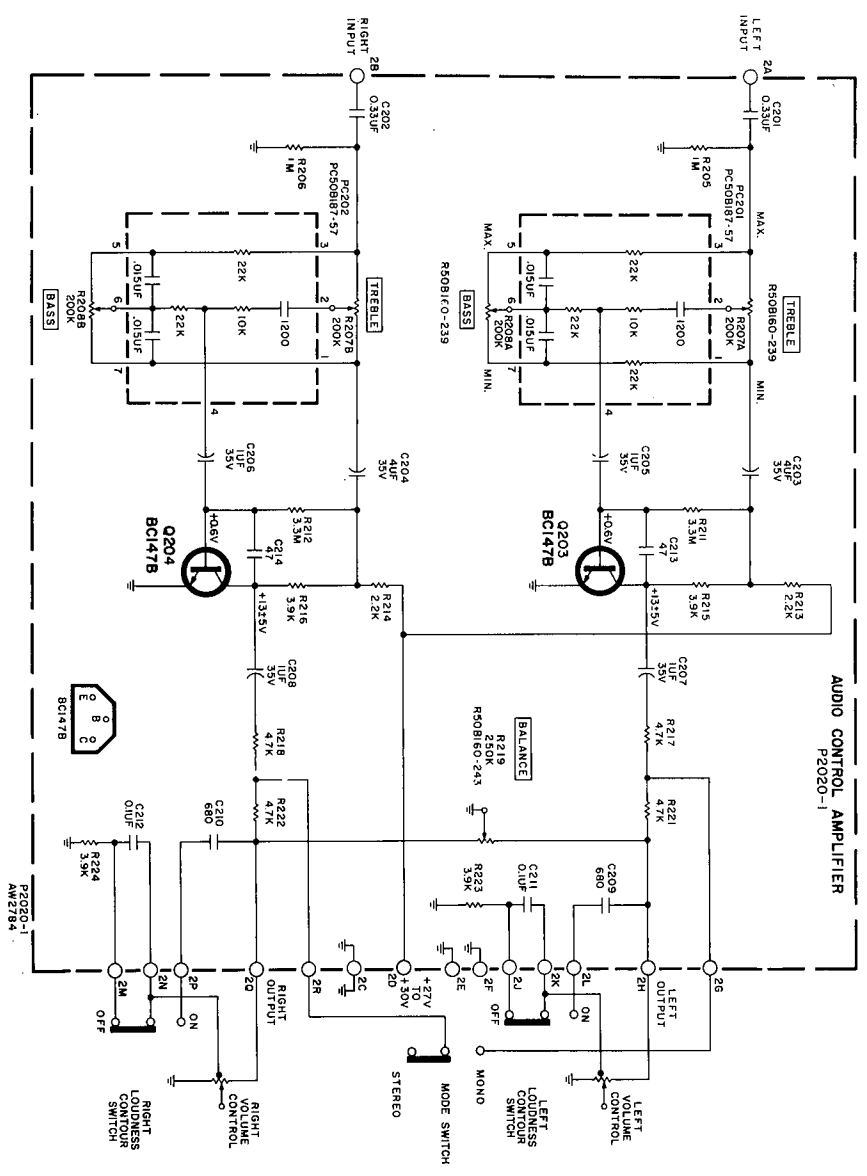

BOARD VIEWED FROM COMPONENT SIDE

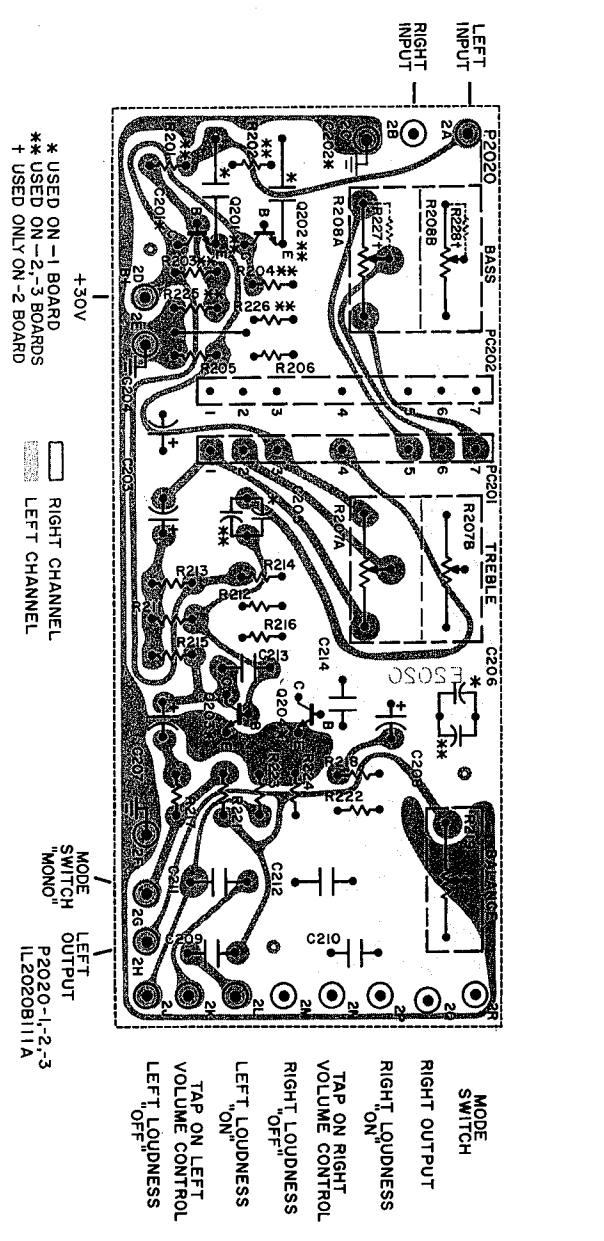

2125-1 POWER AMPLIFIER MODULE

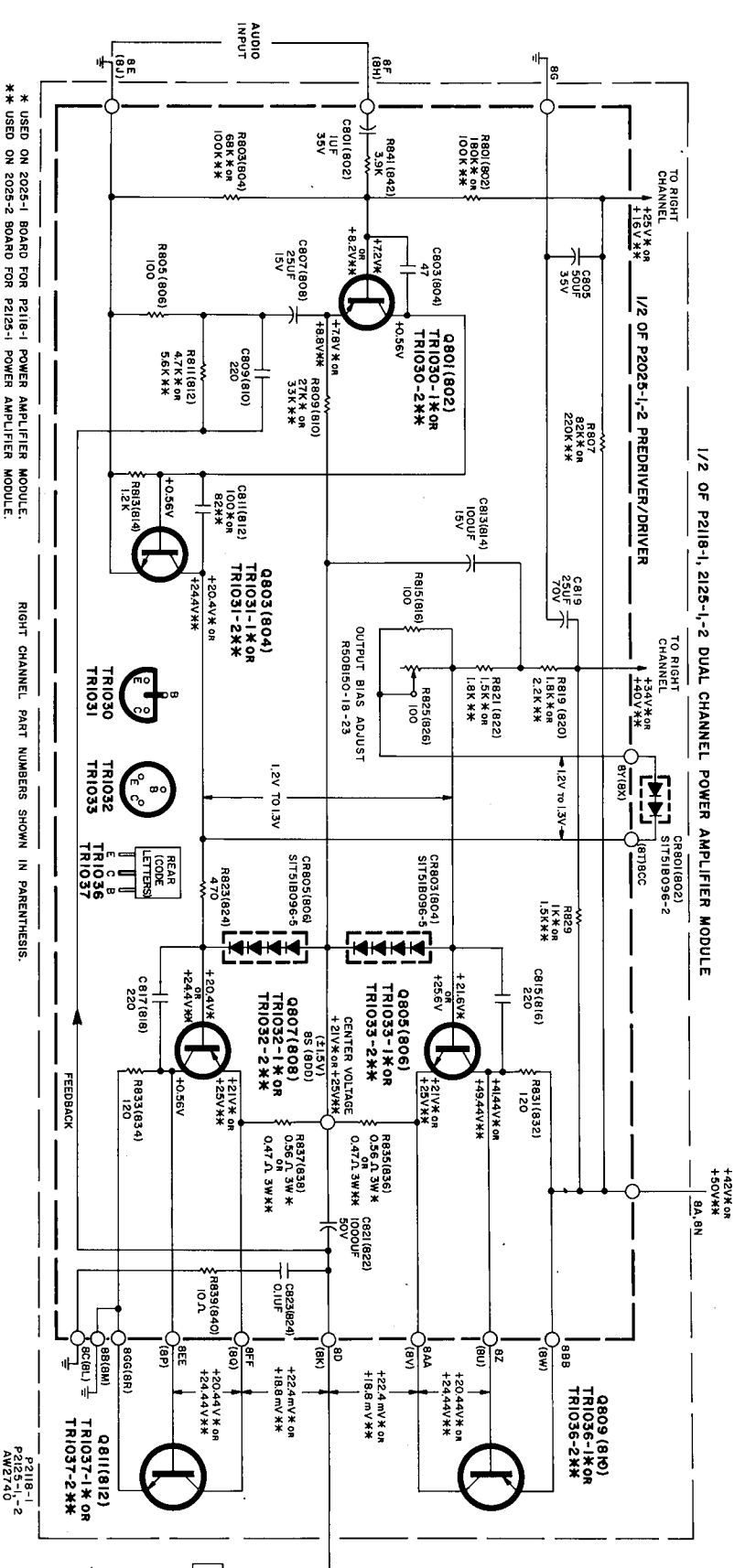

RIGHT CHANNEL PART NUMBERS SHOWN IN PARENTHESIS.
 ** USED ON 2025-2 BOARD FOR P2125-1 POWER AMPLIFIER MODULE.
 * USED ON 2025-1 BOARD FOR P2118-1 POWER AMPLIFIER MODULE.

BOARD VIEWED FROM COMPONENT SIDE

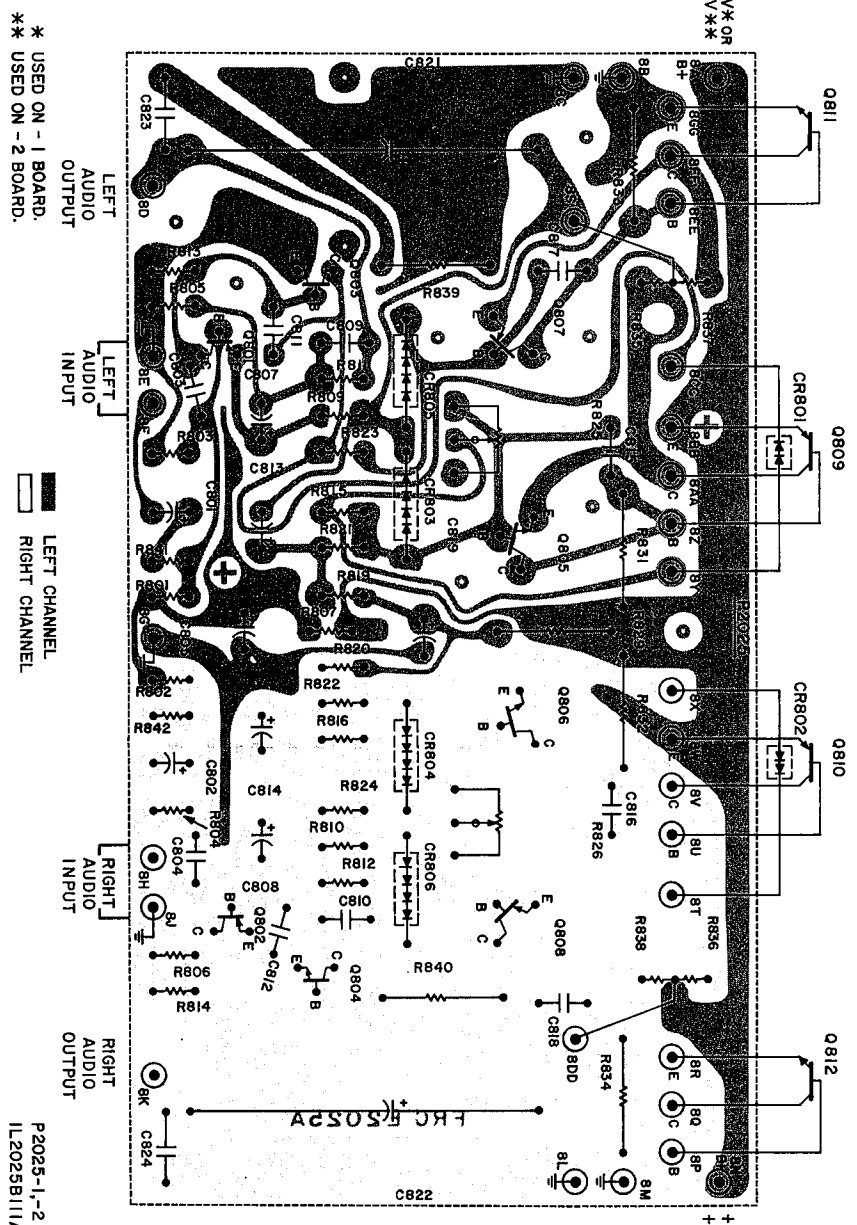

* USED ON - 1 BOARD.
 ** USED ON - 2 BOARD.
 P2025-1,-2
 IL2025B1111A

MAIN CHASSIS

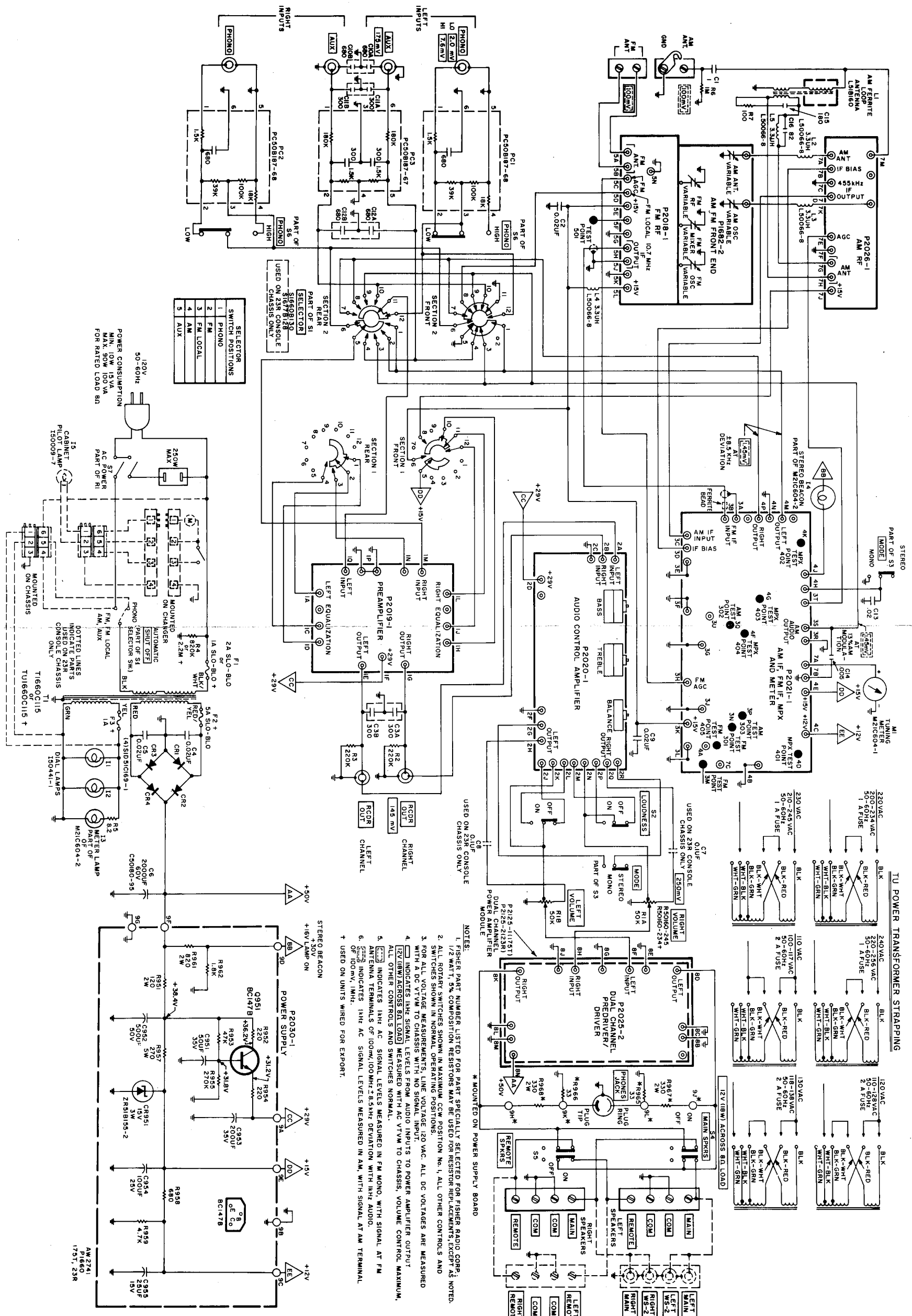

SERVICE NOTES

COMPONENT CONNECTIONS

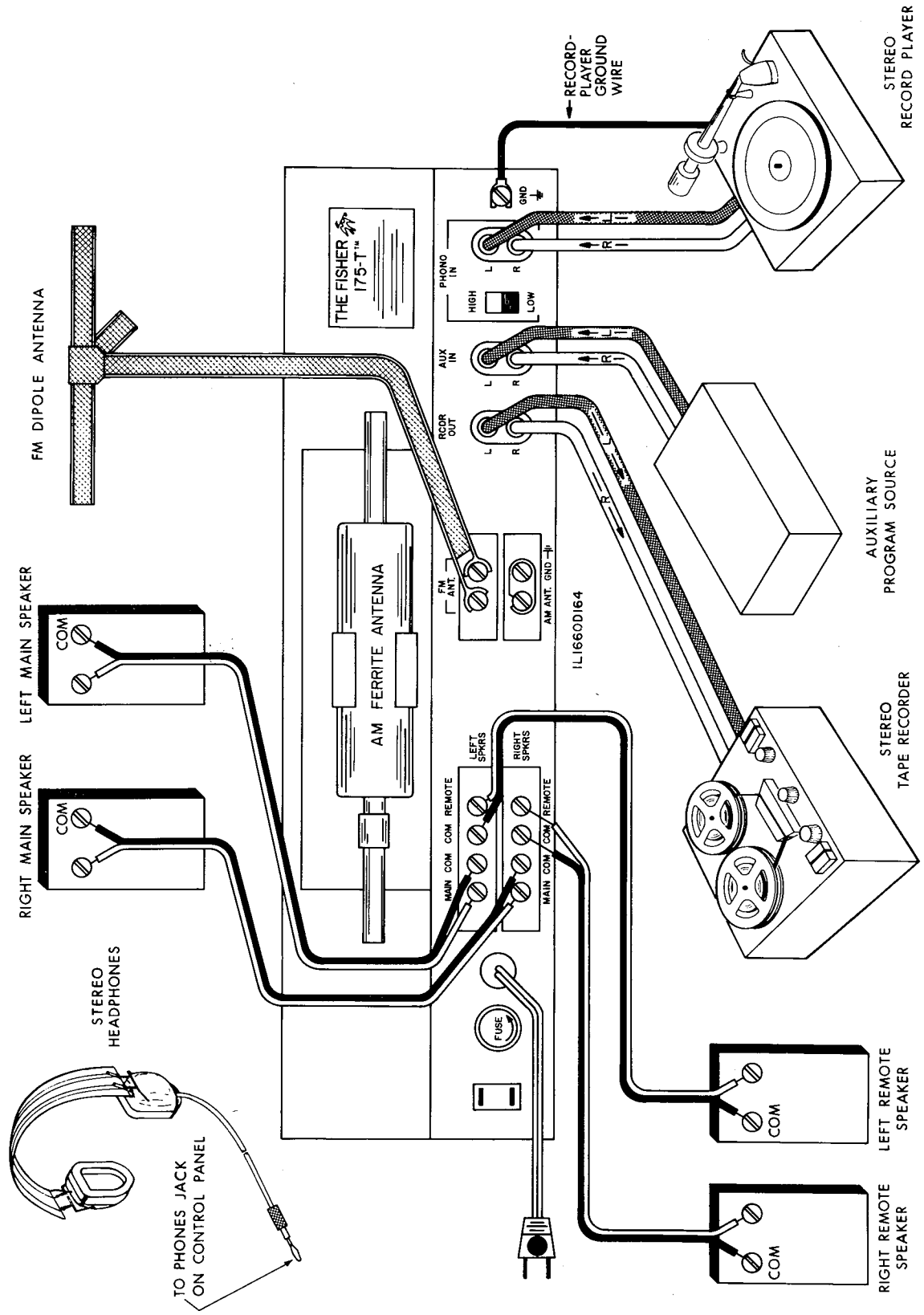

FISHER RADIO CORPORATION · NEW YORK