

SERVICE MANUAL

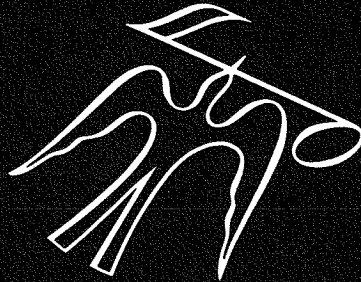

The Fisher® 201

Stereophonic AM-FM Receiver



WORLD LEADER IN HIGH QUALITY STEREO

2 TEST EQUIPMENT and SERVICE TIPS

The following equipment is required to completely test and align modern high-fidelity amplifiers, tuners, and receivers.

- Line Voltage Autotransformer or Voltage Regulator
- DC Vacuum Tube Voltohmmeter
- Accurately Calibrated AC Vacuum Tube Voltmeter
- Oscilloscope (Flat to 100 KHz Minimum)
- Low-Distortion Audio (Sine Wave) Generator
- Intermodulation Distortion Analyzer
- Harmonic Distortion Analyzer
- 2 – Load resistors, 8-Ohms, 100 Watt (Minimum Rating)
- AM/FM Signal Generator
- 10.7 MHz Sweep Generator
- Multiplex Generator (preferably with RF output)
- 455 kHz Sweep Generator
- Ferrite Test Loop Stick
- 2 – Full Range Speakers for Listening Tests
- Stereo Source – Turntable, Tape Recorder, etc.
- Soldering Iron with Small Tip, Fully Insulated from AC Line
- Suction Desoldering Tool

CAUTION: This precision high-fidelity instrument should be serviced only by qualified personnel, trained in the repair of transistor equipment and printed circuitry.

Many of these items are included only as a reminder – they are normal procedures for experienced technicians. Shortcuts may be taken, but these often cause additional damage to transistors, circuit components, or printed circuit boards.

SOLDERING: A well-tinned, hot, clean soldering iron tip will make soldering easier, without causing damage to the printed circuit board or the components mounted on it. Regular use of a sponge cleaner will maintain a clean soldering surface. The heat available at the tip, (not the wattage of the iron) is important. Some 50-watt irons reach temperatures of 1,000° F, while others will hardly melt solder. Small-diameter tips should be used for single solder connections, pyramid and chisel tips for large areas.

Always disconnect the AC power cord from the line when soldering. Turning the power switch OFF is not sufficient. Power-line leakage paths, through the heating element of the iron, may destroy transistors.

PARTS REMOVAL: If a part is not being returned for in-warranty factory replacement, it may be cut in half (with diagonal cutting pliers) to make removal easier. Multiple terminal parts, such as IF transformers, or electrolytic capacitors, should be removed using special de-soldering tips made especially for this purpose. Removing solder from terminals, reduces the possibility of breaking the printed circuit board when the part is removed.

ACCIDENTAL SHORTS: A clean working area, free of metal particles, screws, etc., is an important preventive in avoiding servicing problems. Screws, removed from the chassis during servicing, should be stored in a box until needed. While a set is operating, it takes only an instant for a base-to-collector short to destroy a transistor (and others direct-coupled to it). In the time it takes for a dropped screw, washer, or screwdriver, to contact a pair of terminals (or terminal and chassis), a transistor can be ruined.

SOLID-STATE DEVICES: Integrated Circuits contain the equivalent of many circuit parts, including transistors, diodes, resistors, and capacitors. The preferred troubleshooting procedure requires isolating the trouble to one stage using AC signal tracing methods. Once the suspected stage is located, the DC voltages at the input and output leads are measured to give an accurate indication of the operating conditions of the IC. DO NOT use an ohmmeter to check continuity with the IC mounted on the printed circuit board. Forward biasing the internal junctions within the IC may burn out the transistors. Do not replace a defective IC until all external resistors, capacitors, and transformers are checked first, to prevent the replacement IC from failing immediately due to a defect in the connecting components. Solder and unsolder each lead separately using a pliers or other heat sink on the lead to

prevent damage from excessive heat. Check that the leads are connected to the correct locations on the printed circuit board before turning the set on.

Whenever possible, a transistor tester should be used to determine the condition of a transistor or diode. Ohmmeter checks do not provide conclusive data, and many even destroy the junction(s) within the device.

Never attempt to repair a transistor power amplifier module until the power supply filter-capacitors are fully discharged.

If an output or driver transistor becomes defective (opens or shorts), always check ALL direct-coupled transistors and diodes in that channel. In addition, check the bias pot., and other parts in the bias network, before installing replacement transistors. All output and driver transistors in one channel may be destroyed if the bias network is defective. After parts replacement, check bias for specified idling current.

In some applications, replacement of transistors must be made from the same beta group as the original type. The beta group is indicated by a colored marking on the transistor. Include this information when ordering replacements.

When mounting a replacement power transistor, be sure the bottom of the flange, mica insulator, and the surface of the heat sink, are free of foreign matter. Dust and grit will prevent flat contact, reducing heat transfer to the heat sink. Metallic particles can puncture the insulator, cause a short, and destroy the transistor.

Silicone grease must be used between the transistor and the mica insulator, and between the mica and the heat sink, for best heat transfer. Use Dow-Corning DC-3, or an equivalent compound made for power transistor heat conduction.

Use care when making connections to speakers and output terminals. To reduce the possibility of shorts, lugs should be used on the exposed ends, or stranded wire should be tinned to prevent frayed wire ends. Current in the speakers and output circuitry is quite high – poor contacts, or small wire, can cause significant power losses. For wire lengths greater than 30 feet, 16 AWG, or heavier, should be used.

VOLTAGE MEASUREMENTS: All voltages are measured with the line voltage adjusted to 120 volts. All measured voltages are $\pm 10\%$. DC voltages are measured to ground with a VTVM, with no signal input unless otherwise noted. AC signal voltages are measured under the conditions specified on the schematic.

ALIGNMENT PROCEDURES: DO NOT attempt realignment unless the required test equipment is available, and the alignment procedure is thoroughly understood.

	PAGE		PAGE
REQUIRED TEST EQUIPMENT	2	CONTROL AMPLIFIER	8
MECHANICAL DISASSEMBLY	3	POWER AMPLIFIER	9
DIAL STRINGING	4	FM RF	10
HARMONIC DISTORTION TEST	4	MULTIPLEX	11
CHASSIS LAYOUT	5	AM, FM IF, and METER	12, 13
POWER SUPPLY	6	TUNER ALIGNMENT	14, 15
MAIN CHASSIS	7	AM RF	16
PREAMPLIFIER	8	COMPONENT CONNECTIONS	16

REMOVING DRESS PANEL

- (1) Unplug AC power cord.
- (2) Remove the screws securing the top and bottom covers to the chassis. Remove the covers.
- (3) Gently pull off the SELECTOR, VOLUME, BALANCE, TREBLE, BASS, POWER/SPKRS and Tuning control knobs from the control shafts.
- (4) Remove the two screws on the top and two screws on the bottom of the chassis securing the dress panel to the chassis. Remove the dress panel by pulling it forward.
- (5) Reverse the procedure for reassembly.

REMOVING TUNING METER AND STEREOBEAM INDICATOR LAMP

- (1) Remove dress panel. Refer to REMOVING DRESS PANEL procedure.
- (2) Remove the two screws on the bottom side of the chassis, located above the VOLUME NORMAL-LOW switch, securing the bracket of the tuning meter and STEREOBEAM indicator lamp. Note the ground lug of resistor R8 secured to the bracket.
- (3) Remove tuning meter and STEREOBEAM indicator lamp.
- (4) Reverse the procedure for reassembly.

REMOVING DIAL LAMPS

- (1) Unplug AC power cord.
- (2) Remove the screws securing the top and bottom covers of the chassis. Remove the covers.
- (3) Remove the two screws on top of dial glass and meter housing. Slide dial lamp bracket to the rear, and gently drop the bracket to get to the dial lamps.
- (4) Replace defective lamp.
- (5) Reverse the procedure for replacement of lamp bracket.

REMOVAL OF POWER TRANSFORMER

To remove the power transformer, remove three screws securing power transformer to its mounting bracket.

REMOVING DIAL GLASS

- (1) Remove the dress panel. Refer to REMOVING DRESS PANEL procedure.
- (2) Remove screw attaching ground lug of resistor R8 to tuning meter and STEREOBEAM indicator bracket located on the chassis above the VOLUME NORMAL-LOW switch.
- (3) Tape dial cord to tuning drum. Remove dial cord from the pulley which is attached to the dial housing.
- (4) Remove the four screws securing the dial glass and meter housing to the front chassis.
- (5) Remove the dial glass and meter housing.
- (6) Remove the dial pointer by sliding its mounting carrier from its sliding rail.
- (7) Very gently lift up the dial glass and meter housing and turn the housing towards you. Take a knife and gently detach the indicator holder and meter secured to the dial glass by double-sided adhesive tape.
- (8) Use a knife and pry loose the dial glass, taking care not to damage the foam rubber mountings.
- (9) Reverse procedure for reassembly.

REMOVING PRINTED CIRCUIT BOARDS

- (1) Unplug AC power cord. Remove the screws securing the top and bottom covers to the chassis. Remove the covers.
- (2) Remove the screws securing printed boards to the chassis. **NOTE:** MPX Board is mounted on a hinge. Remove two screws close to AM RF Board. The MPX Board can now be hinged allowing access to the AM, FM IF, and Meter Board.
- (3) Remove dress panel. Refer to REMOVING DRESS PANEL procedure.
- (4) Remove hex nuts from VOLUME, BALANCE, TREBLE, and BASS controls. Remove Control Amplifier Board.
- (5) Remove screw which secures clamp holding both Driver Boards in place.
- (6) Pull Driver Boards straight up to remove boards from plug-in sockets, and gain access to output transistors.
- (7) Remove screw which secures heat sink bracket of transistor Q01 of Power Supply Board to chassis.
- (8) Remove the screws which secure Power Supply Board to chassis, and remove board.
- (9) Remove snap-on shield of FM RF Board. Remove two screws securing tuning drum to tuning capacitor shaft. Slide drum off the shaft.
- (10) Remove screws securing FM RF Board, and remove board.

4 DIAL STRINGING

HARMONIC DISTORTION TEST

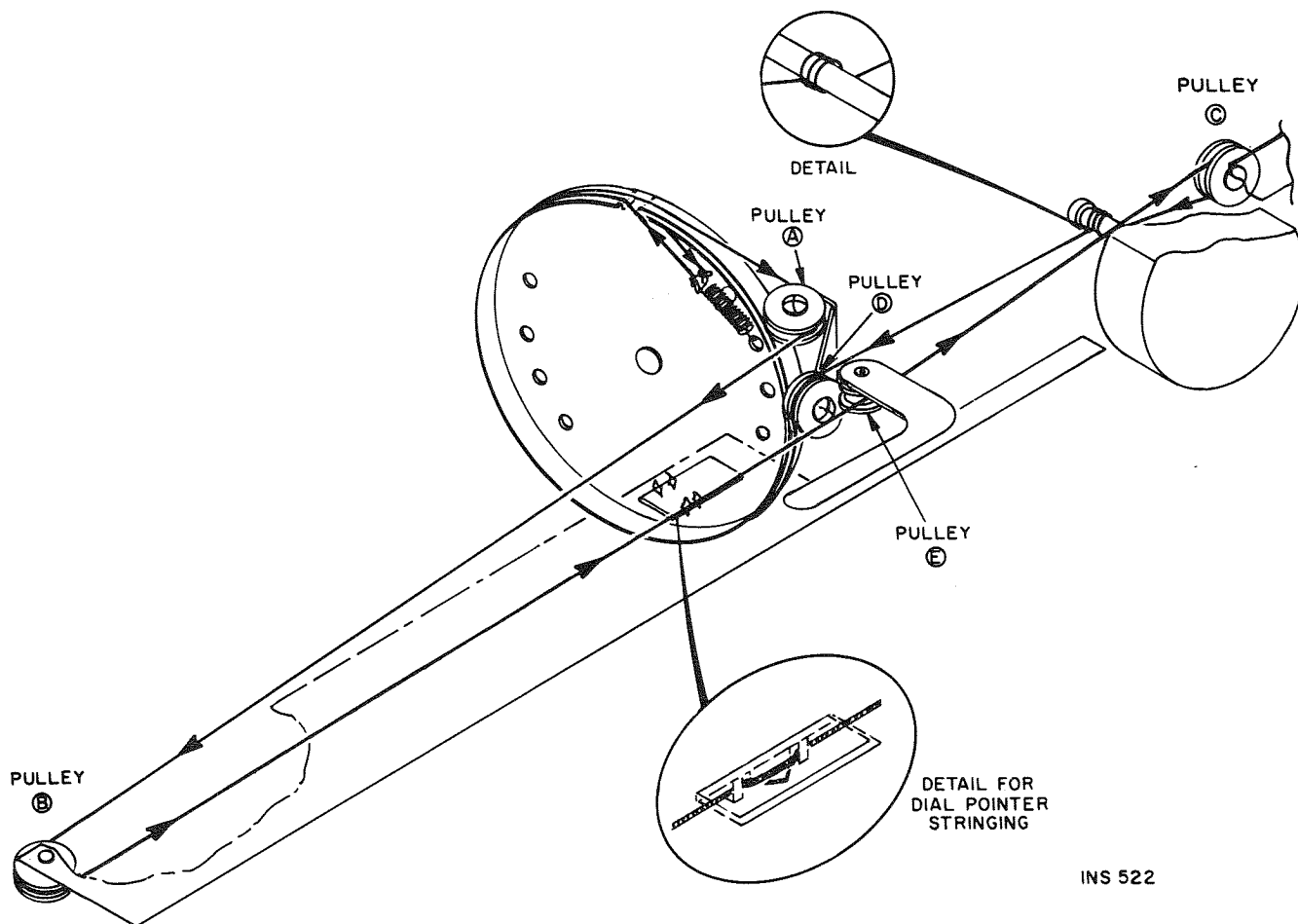

DIAL STRINGING

- (1) Remove screws securing top and bottom covers to receiver chassis. Remove covers. Unsnap pointer from its sliding carrier. Remove carrier from the rail.
- (2) Rotate tuning drum fully clockwise.
- (3) Remove old dial cord. Be careful not to remove dial spring from its ear in the drum.
- (4) Tie end of new cord to end of dial spring. Make sure that dial spring is fastened to tuning drum as shown in the figure.
- (5) Guide dial cord through rim slot and wind a full turn around drum. Guide cord around pulleys A, B, and C and over pulley E. Wind dial cord three times around tuning shaft and

over pulley D. Wind cord 3/4 turn around tuning drum and through rimslot.

- (6) Pull dial cord taut and hook cord to end of dial spring.
- (7) Rotate tuning drum clockwise and counterclockwise to distribute the tensioning.
- (8) Repeat steps (6) and (7) until spring is tensioned. Then tie dial cord securely to end of spring.
- (9) Place dial cord over and under tabs on pointer carrier (see figure). Snap pointer into sliding carrier.
- (10) Turn tuning drum fully counterclockwise. Slide pointer to indicate zero on tuning dial while holding tuning drum fully counterclockwise.
- (11) Check dial calibration. Refer to FM/AM ALIGNMENT.

HARMONIC DISTORTION TEST

CAUTION:

- (A) Measure the power of one channel at a time.
 - (B) Limit measurements to 10 minutes.
 - (C) Use a load resistor with a minimum rating of 50 watts.
- (1) Set BASS and TREBLE controls to flat (0), SELECTOR switch to AUX 1, and POWER/SPKRS switch to AC OFF.
 - (2) Connect a low-distortion sine wave signal generator between L AUX 1 IN jack and chassis ground. Set the signal generator frequency to 1000 Hz and output level to minimum.

- (3) Connect the 8-ohm load resistor between L MAIN SPKR and COM terminals. Connect an AC VTVM, oscilloscope, and harmonic distortion analyzer across the 8-ohm load resistor.
- (4) Set POWER/SPKRS switch to MAIN. Turn VOLUME control slowly to maximum.
- (5) Adjust the signal generator output until the AC VTVM indicates 12.6V RMS (20 watts). The HD analyzer should indicate less than 1% harmonic distortion.
- (6) Repeat steps (1) through (5) for the right channel.

CHASSIS LAYOUT 5

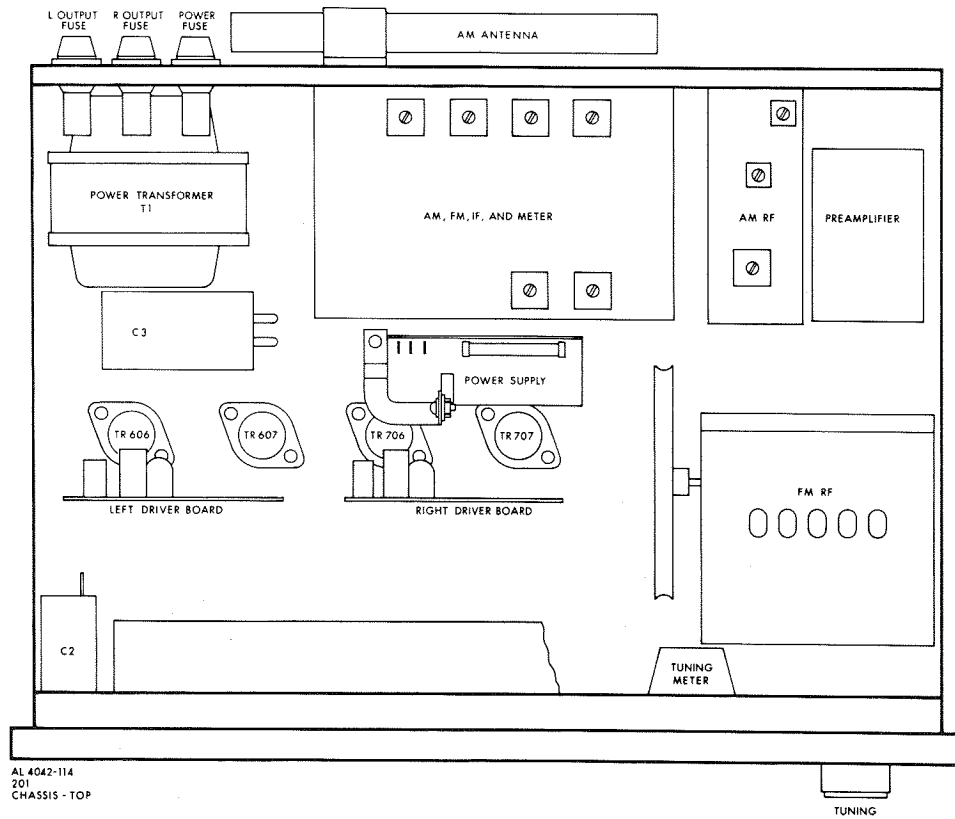

top view

AL 4042-114
201
CHASSIS - TOP

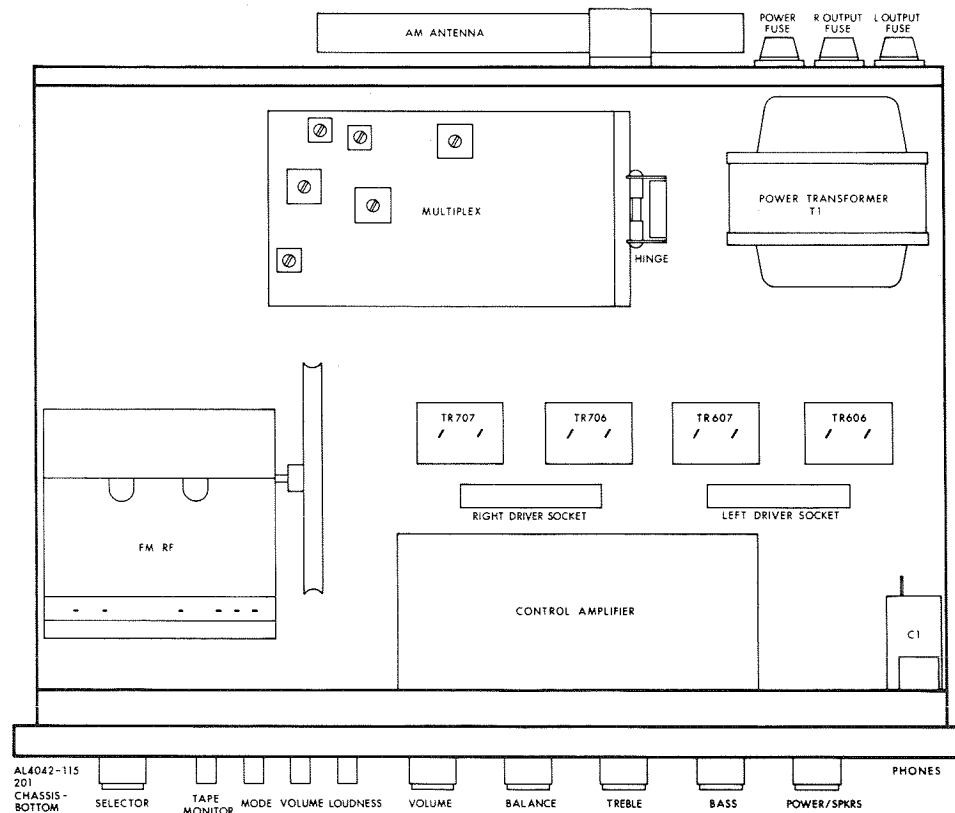

bottom view

AL4042-115
201
CHASSIS -
BOTTOM

6 POWER SUPPLY

schematic shown on main chassis diagram

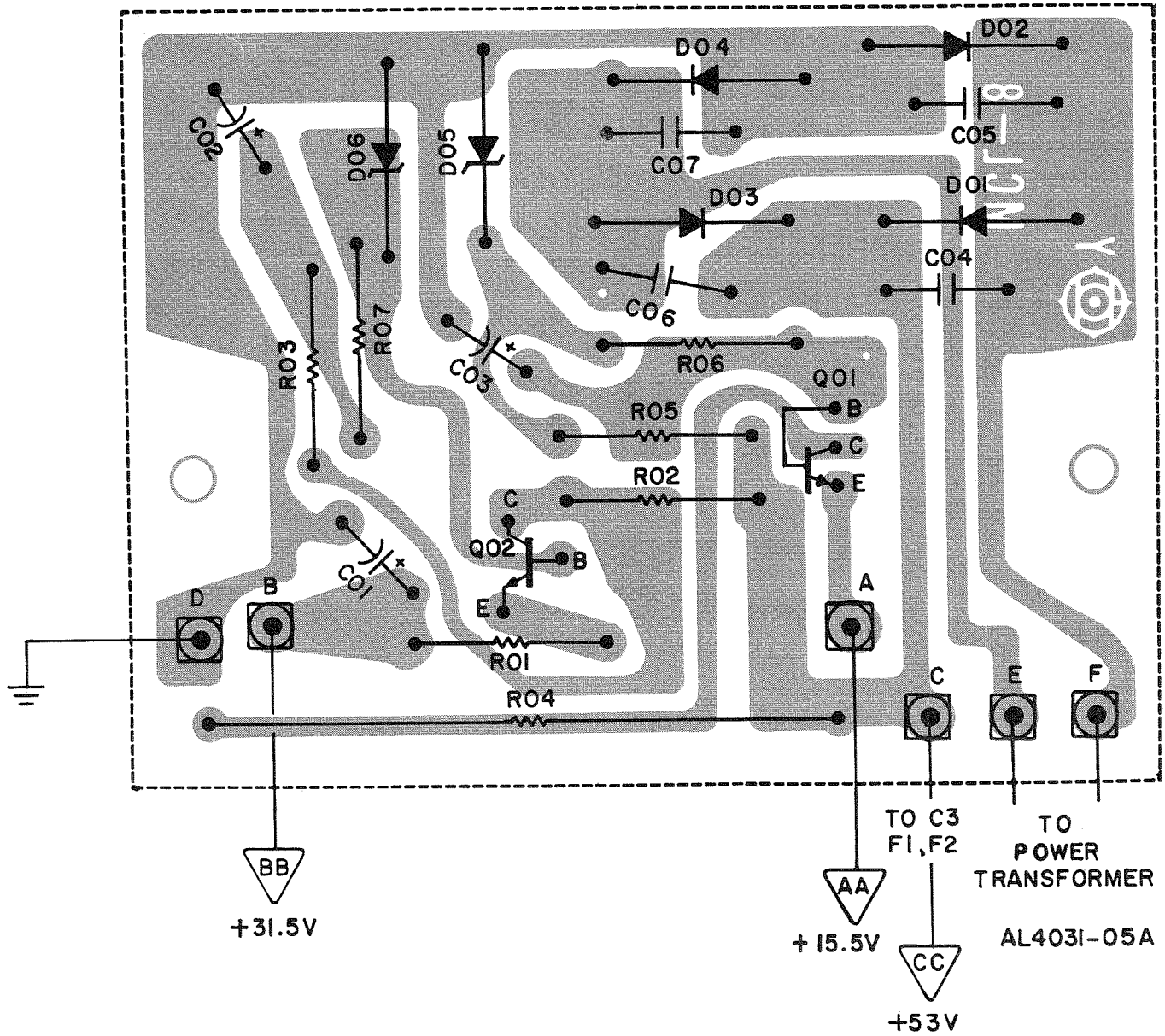

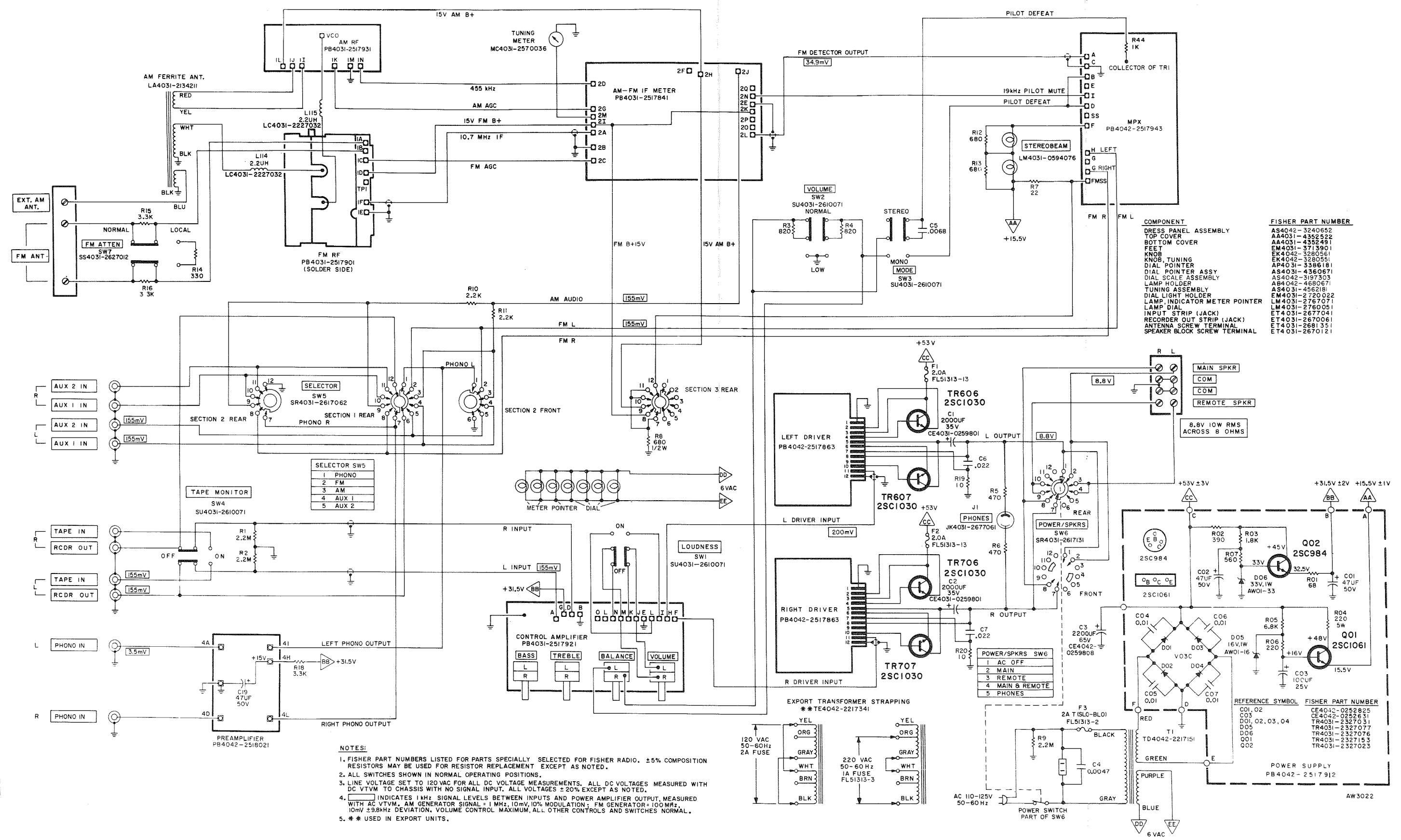

COMPONENT	FISHER PART NUMBER
DRESS PANEL ASSEMBLY	AS4042-324052
TOP COVER	AA4031-435252
BOTTOM COVER	AA4031-4352491
FEET	EM4031-3713901
KNOB	EK4042-3280561
KNOB TUNING	EK4042-3280551
DIAL POINTER	AP4031-3386181
DIAL POINTER ASSY	AS4031-4360671
DIAL SCALE ASSEMBLY	AS4042-3197303
LAMP HOLDER	AB4042-4680671
TUNING ASSEMBLY	AS4031-456218
DIAL LIGHT HOLDER	EM4031-2720022
LAMP INDICATOR METER POINTER	LM4031-2767071
LAMP DIAL	LM4031-2760051
INPUT STRIP (JACK)	ET4031-2677041
RECORDER OUT STRIP (JACK)	ET4031-2670061
ANTENNA SCREW TERMINAL	ET4031-2681351
SPEAKER BLOCK SCREW TERMINAL	ET4031-2670121

REFERENCE SYMBOL	FISHER PART NUMBER
C01, 02	CE4012-0252825
C03	CE4042-0252631
D01, 02, 03, 04	TR4031-2327031
D05	TR4031-2327077
D06	TR4031-2327076
Q01	TR4031-2327153
Q02	TR4031-2327023

- NOTES:**
- FISHER PART NUMBERS LISTED FOR PARTS SPECIALLY SELECTED FOR FISHER RADIO. ±5% COMPOSITION RESISTORS MAY BE USED FOR RESISTOR REPLACEMENT EXCEPT AS NOTED.
 - ALL SWITCHES SHOWN IN NORMAL OPERATING POSITIONS.
 - LINE VOLTAGE SET TO 120 VAC FOR ALL DC VOLTAGE MEASUREMENTS. ALL DC VOLTAGES MEASURED WITH DC VTVM. AM GENERATOR SIGNAL = 1 MHz, 10mV, 10% MODULATION; FM GENERATOR = 100 MHz, 10mV ±9.8kHz DEVIATION, VOLUME CONTROL MAXIMUM, ALL OTHER CONTROLS AND SWITCHES NORMAL.
 - INDICATES 1 kHz SIGNAL LEVELS BETWEEN INPUTS AND POWER AMPLIFIER OUTPUT, MEASURED WITH AC VTVM. AM GENERATOR SIGNAL = 1 MHz, 10mV, 10% MODULATION; FM GENERATOR = 100 MHz, 10mV ±9.8kHz DEVIATION, VOLUME CONTROL MAXIMUM, ALL OTHER CONTROLS AND SWITCHES NORMAL.
 - ** USED IN EXPORT UNITS.

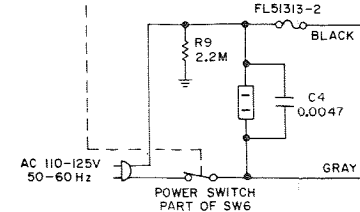
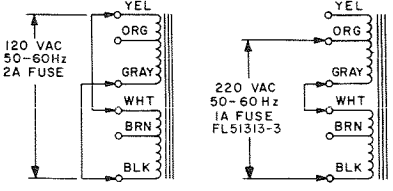

POWER SUPPLY
PB4042-2517912
AW3022

8 PREAMPLIFIER

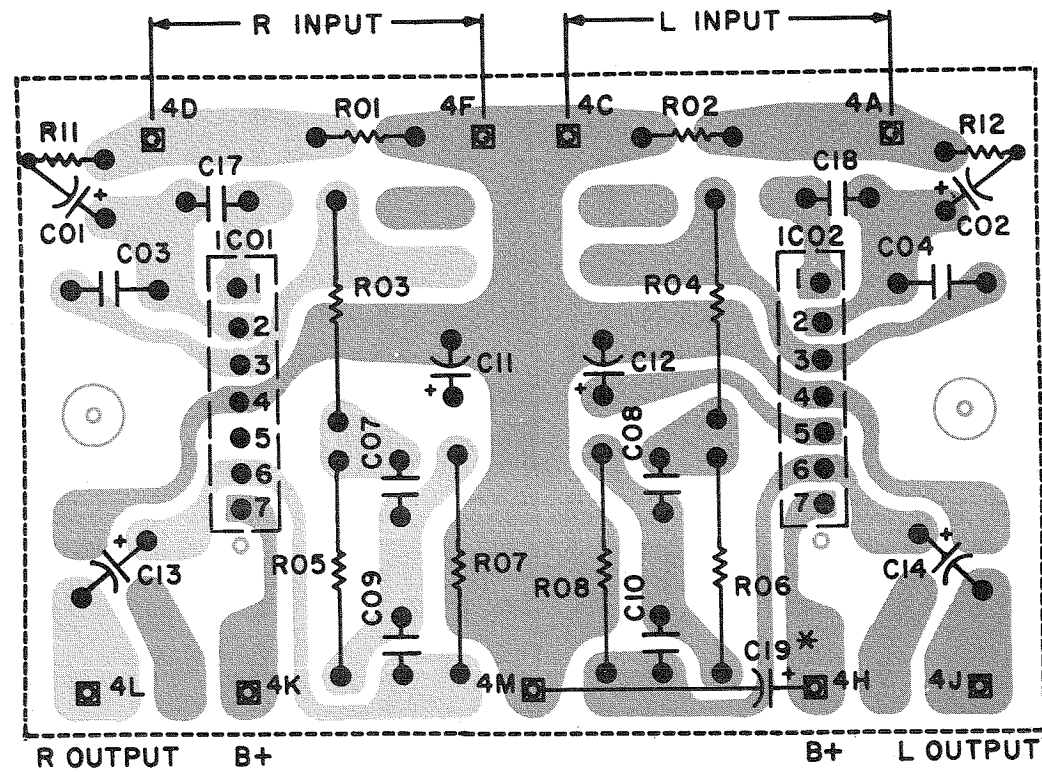
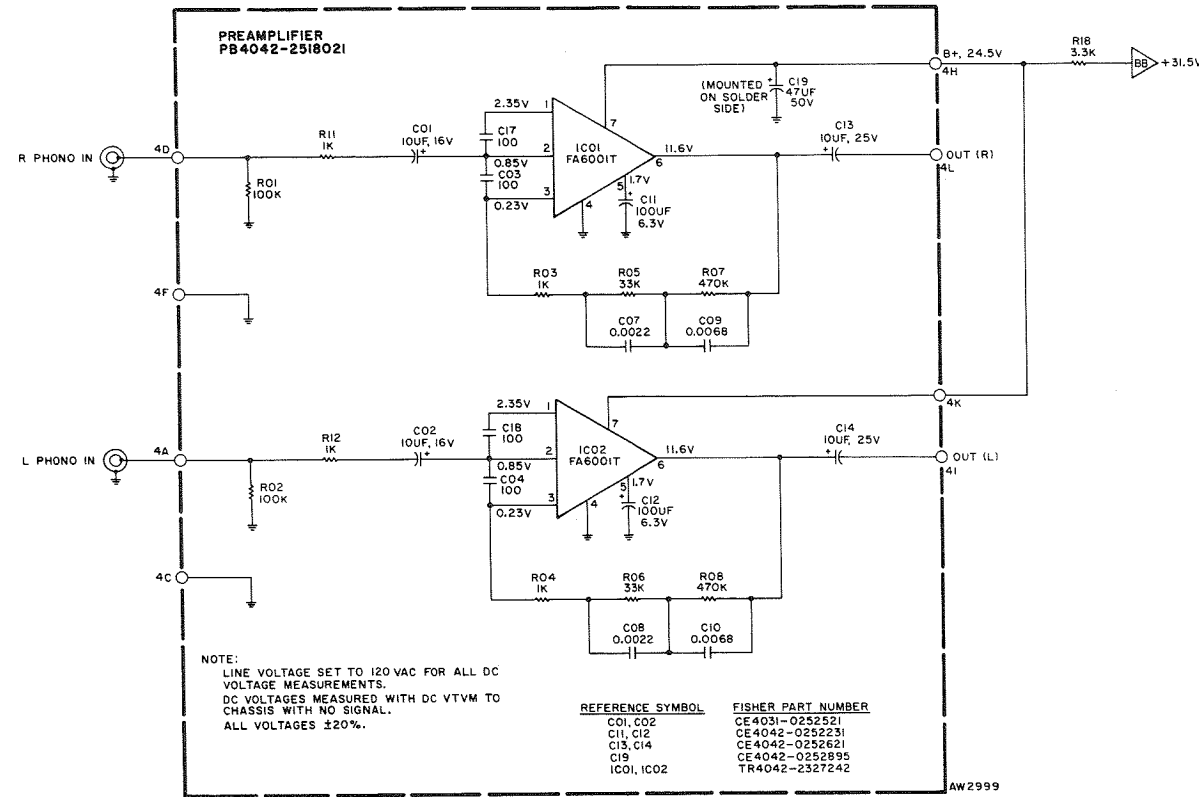

* DENOTES COMPONENTS MOUNTED ON SOLDER SIDE
 ■ LEFT CHANNEL □ RIGHT CHANNEL AL4042-01

CONTROL AMPLIFIER

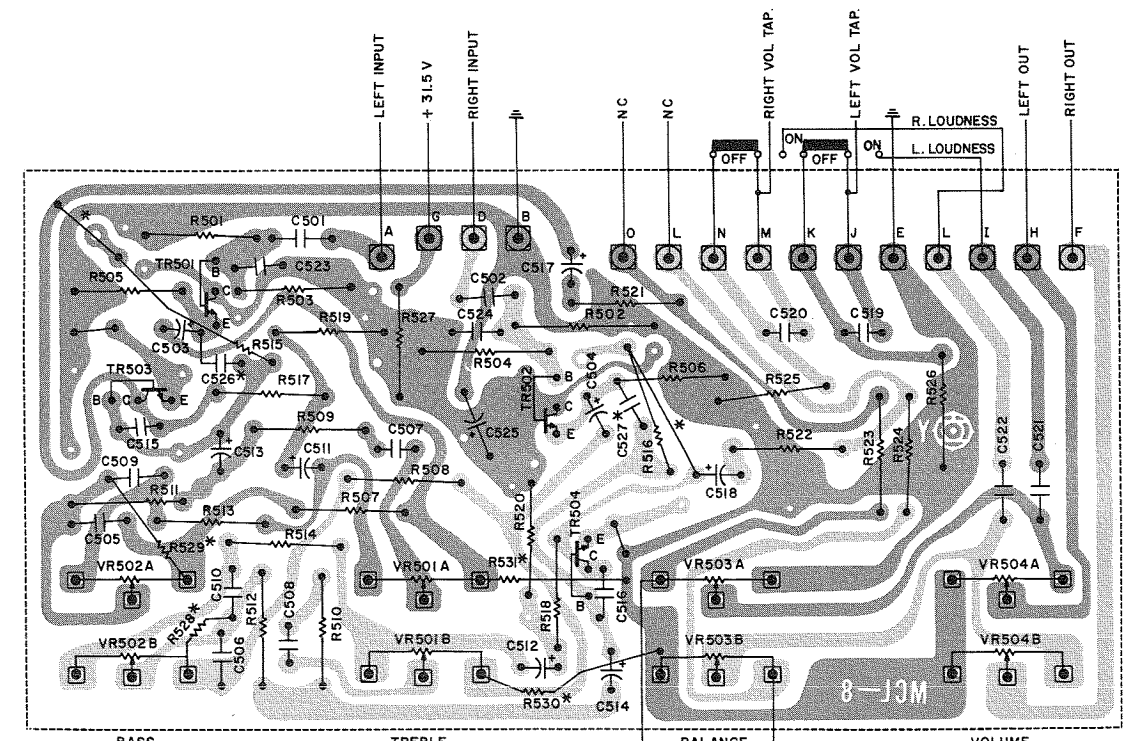
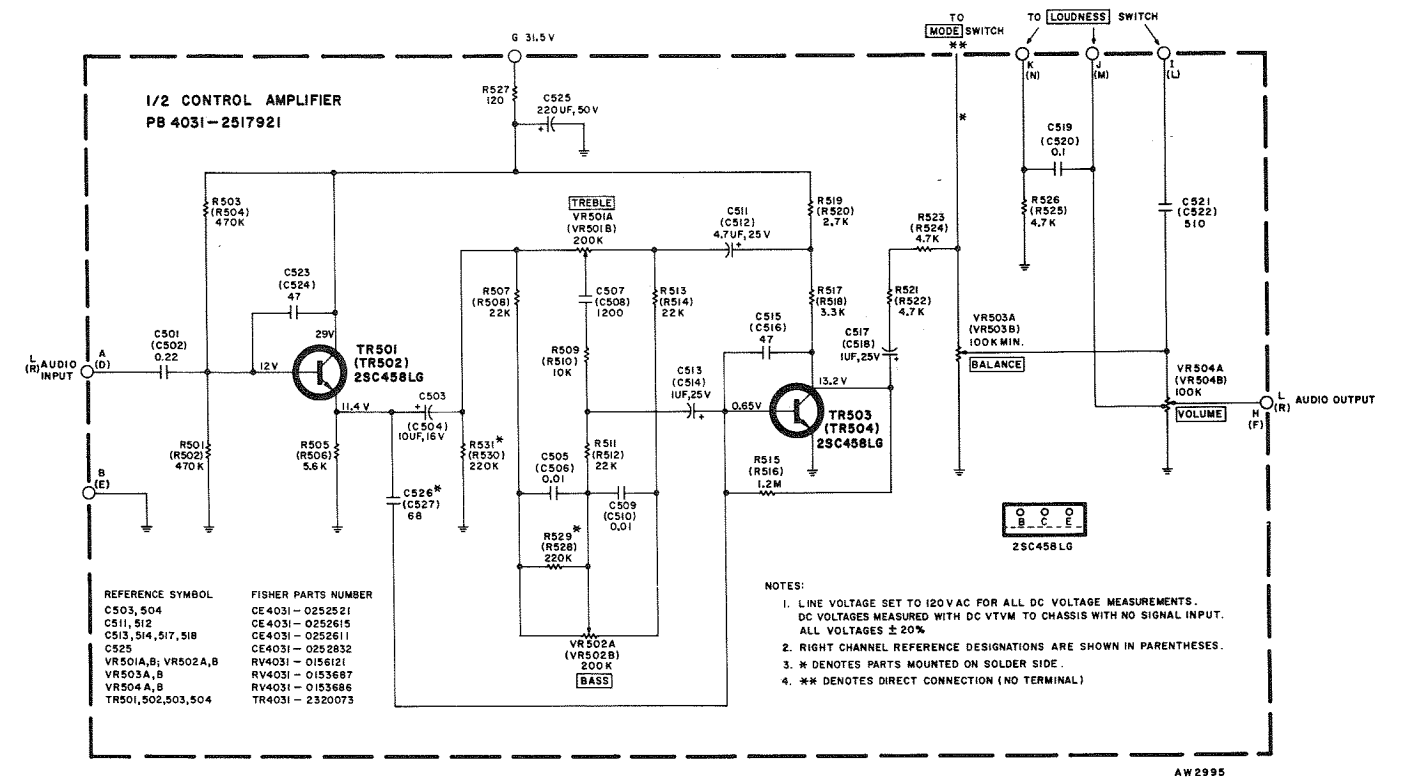

■ LEFT CHANNEL □ RIGHT CHANNEL
 * DENOTES COMPONENT ON SOLDER SIDE AL4031-07

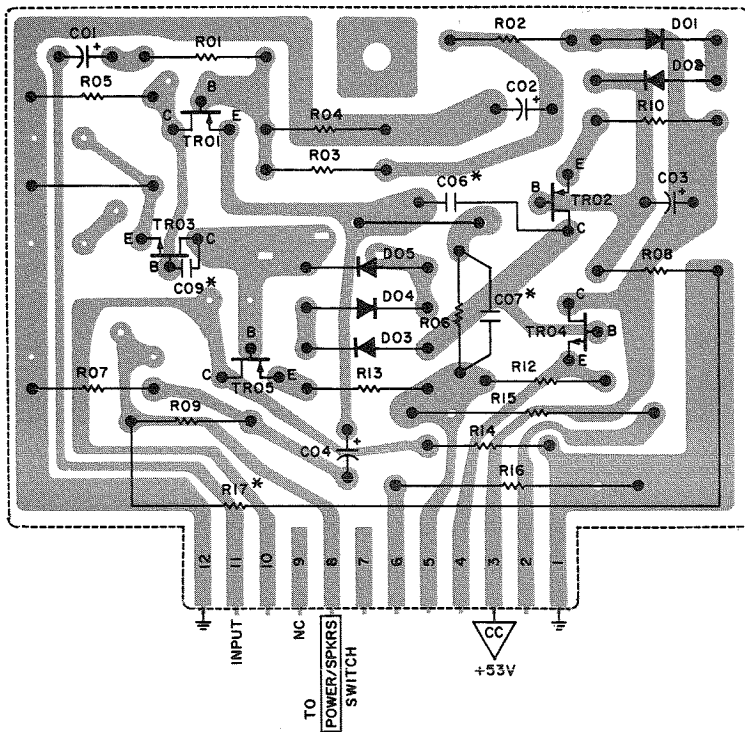
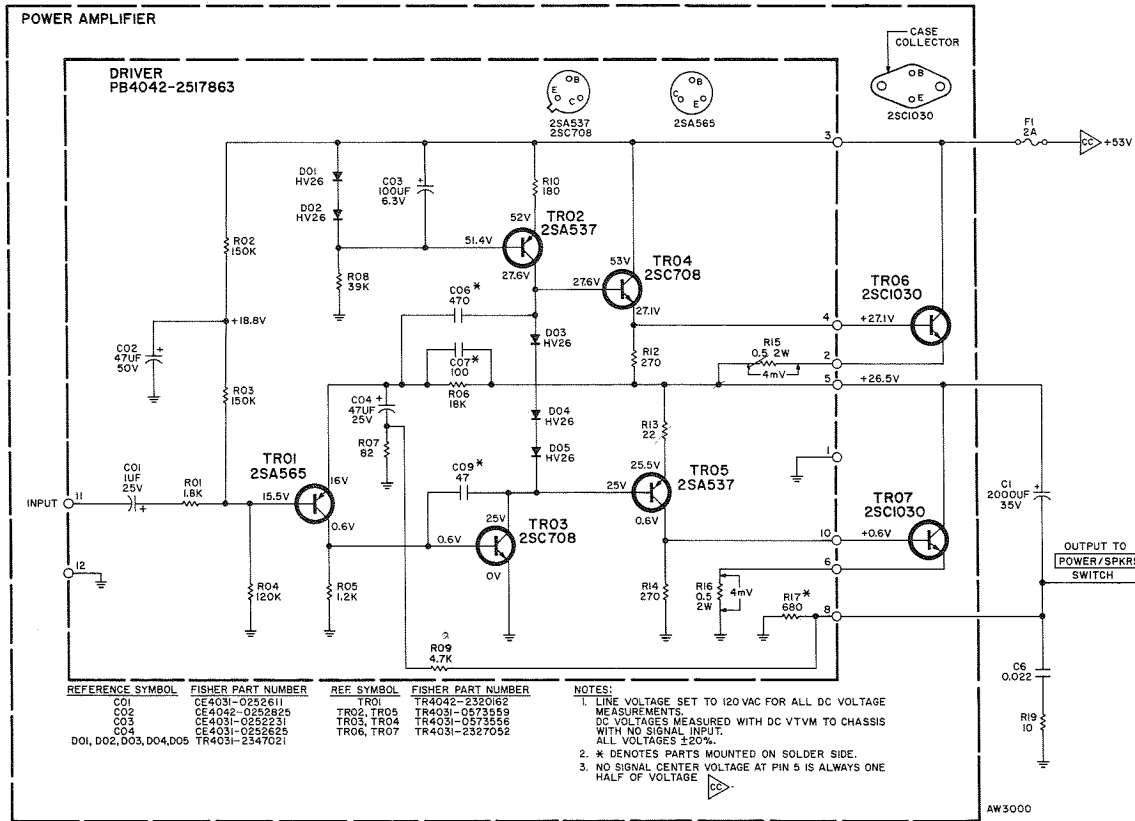

* DENOTES COMPONENTS MOUNTED ON SOLDER SIDE

CENTER VOLTAGE TEST

- (1) Connect DC VTVM between pin 3 of left channel Driver Board and chassis ground. Connect AC power cord. Set POWER/SPKRS switch to MAIN.
- (2) Note the DC VTVM indication.
- (3) Connect DC VTVM between pin 5 of left channel Driver Board and chassis ground.
- (4) The DC VTVM indication should be half the indication noted in step (2) ± 2 VDC.
- (5) Repeat steps (1) through (4) for the right channel Driver Board.

10 FM RF

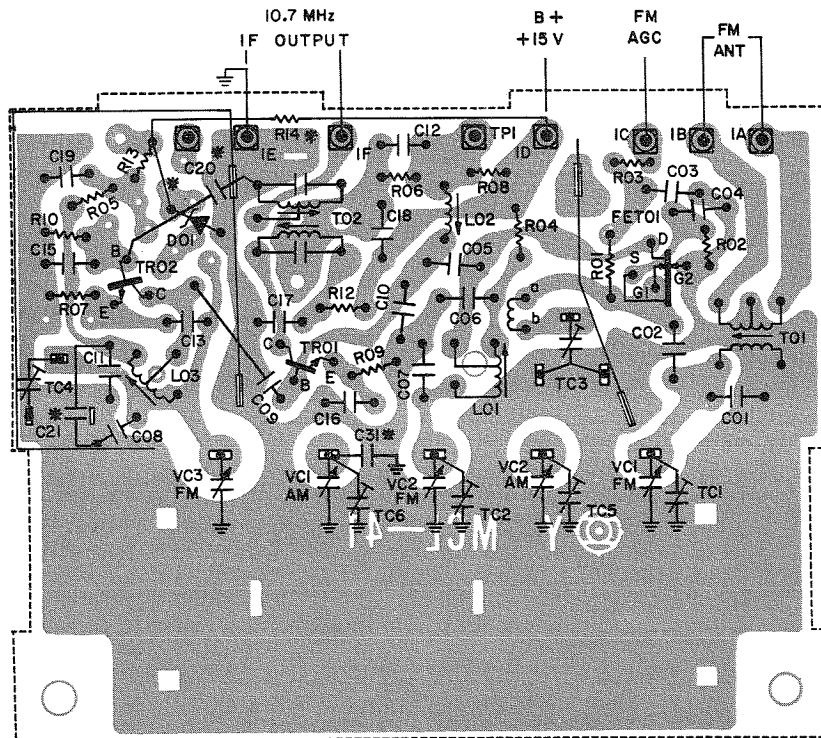
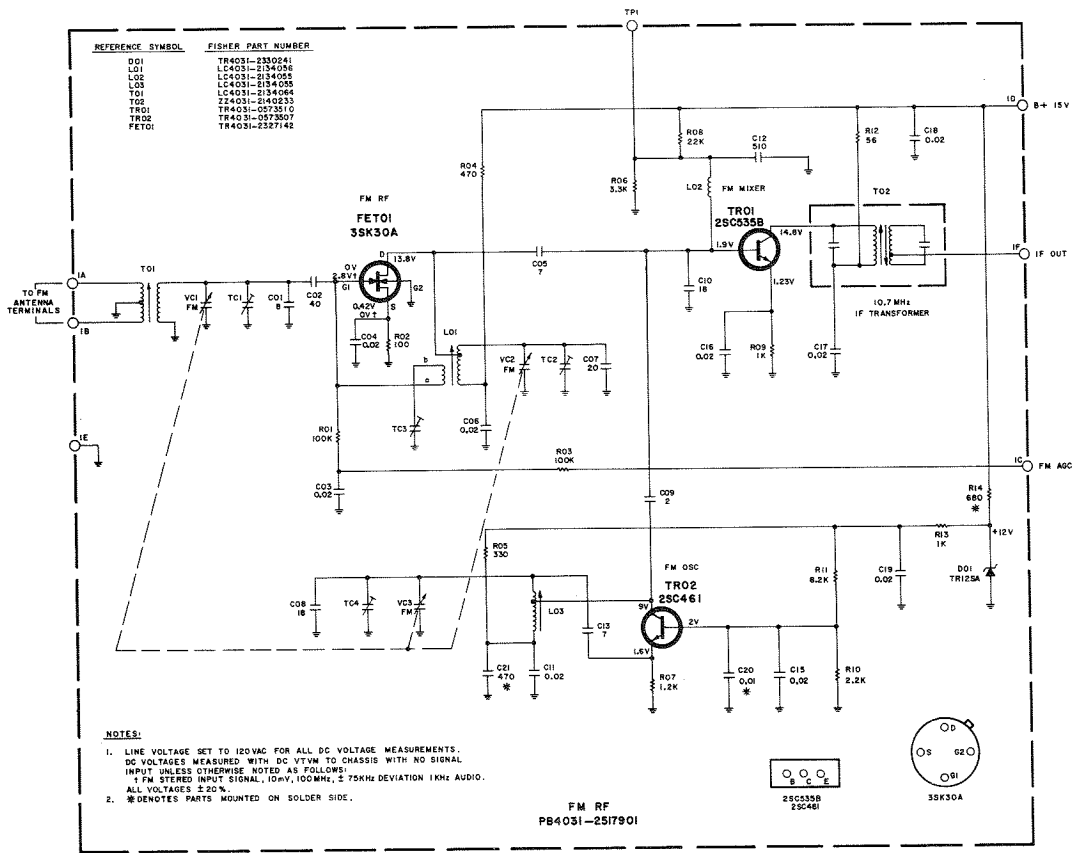

AL4031-06

*DENOTES PARTS MOUNTED ON SOLDER SIDE

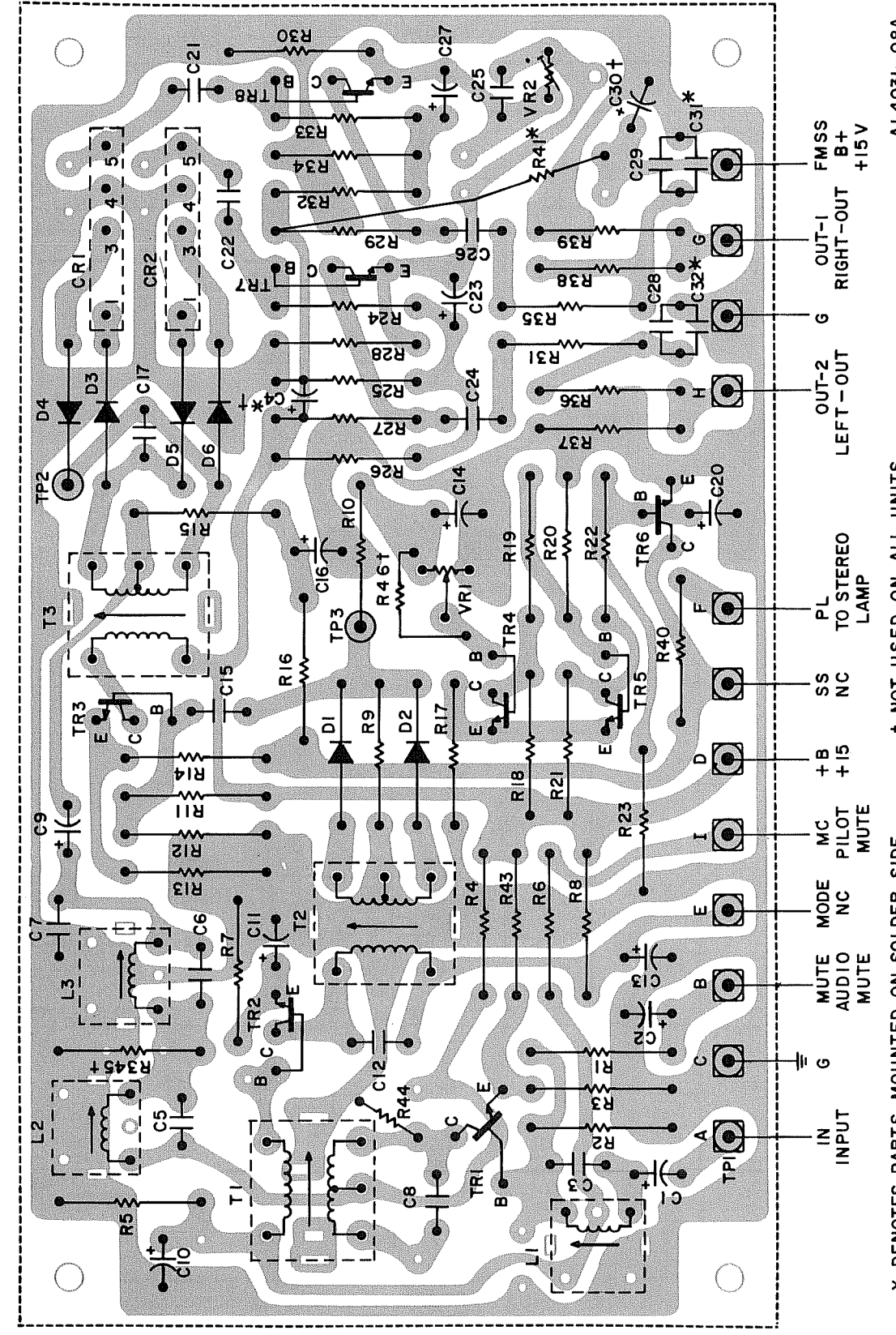
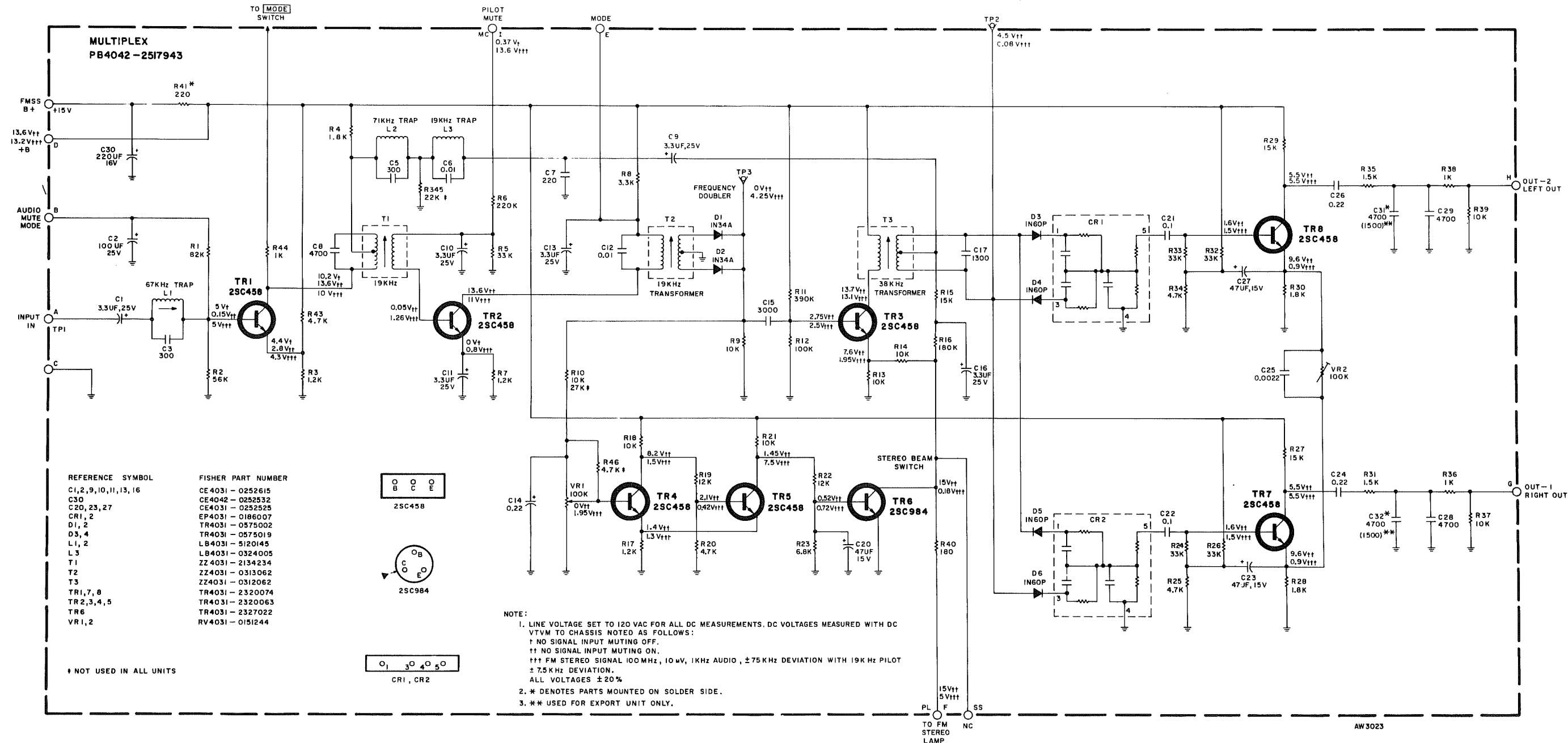

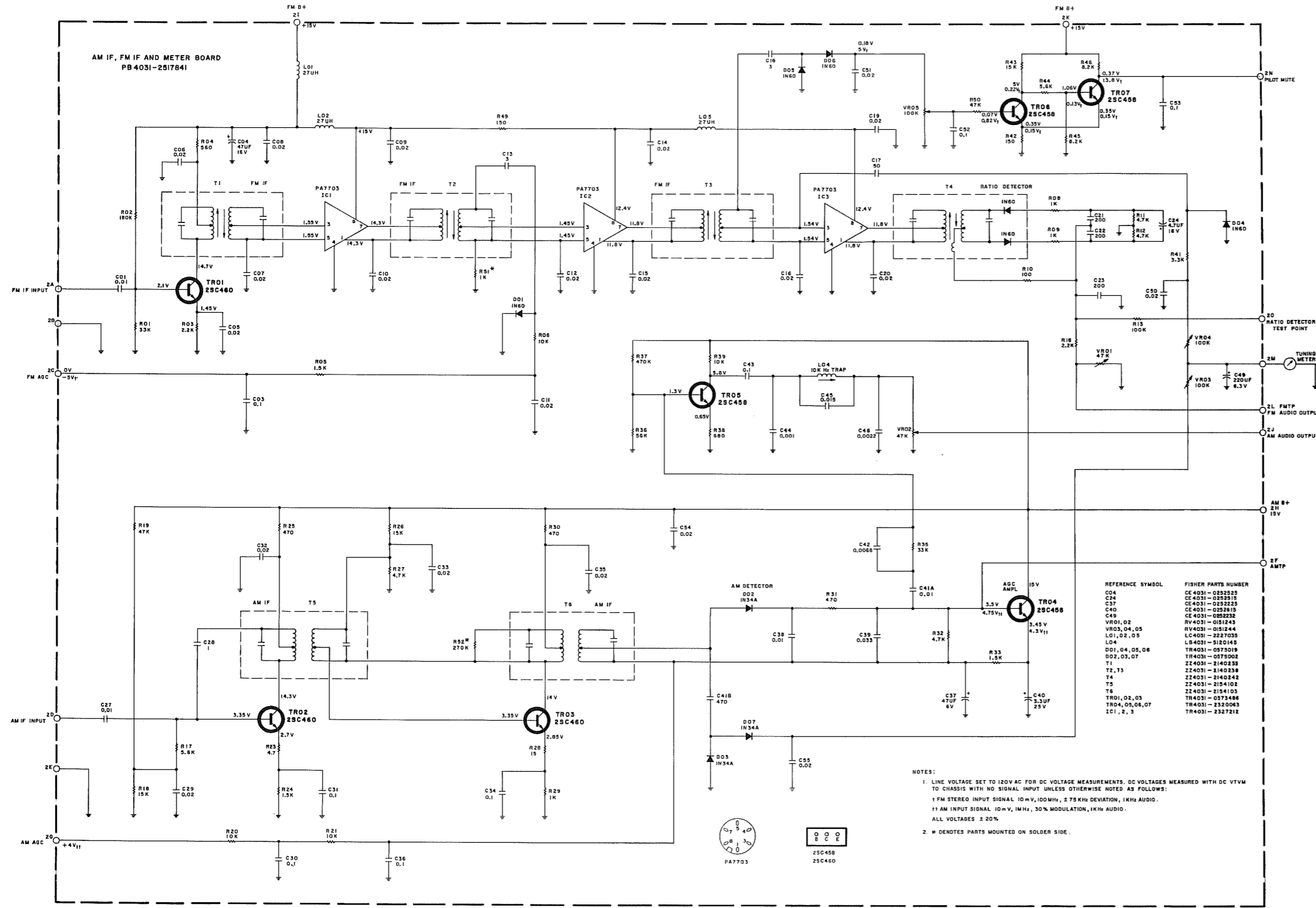

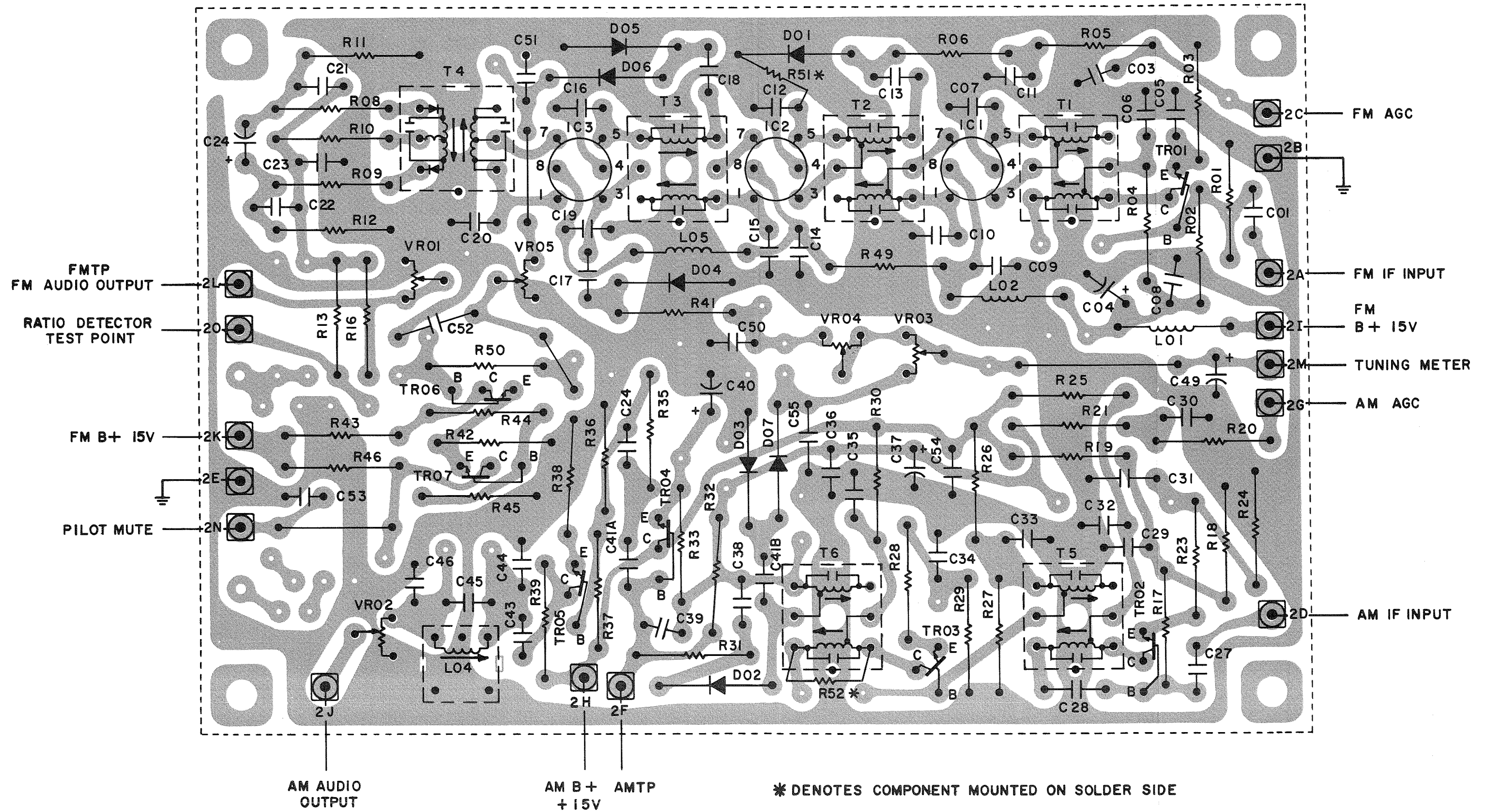

AL4031-01A

14 TUNER ALIGNMENT

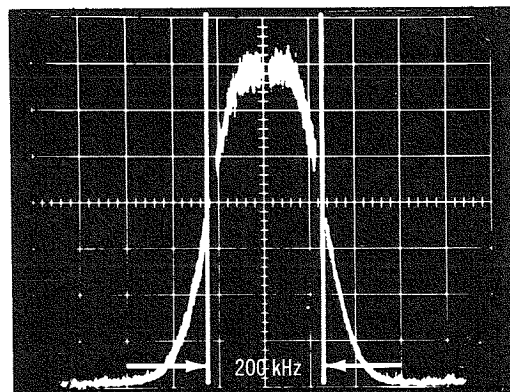
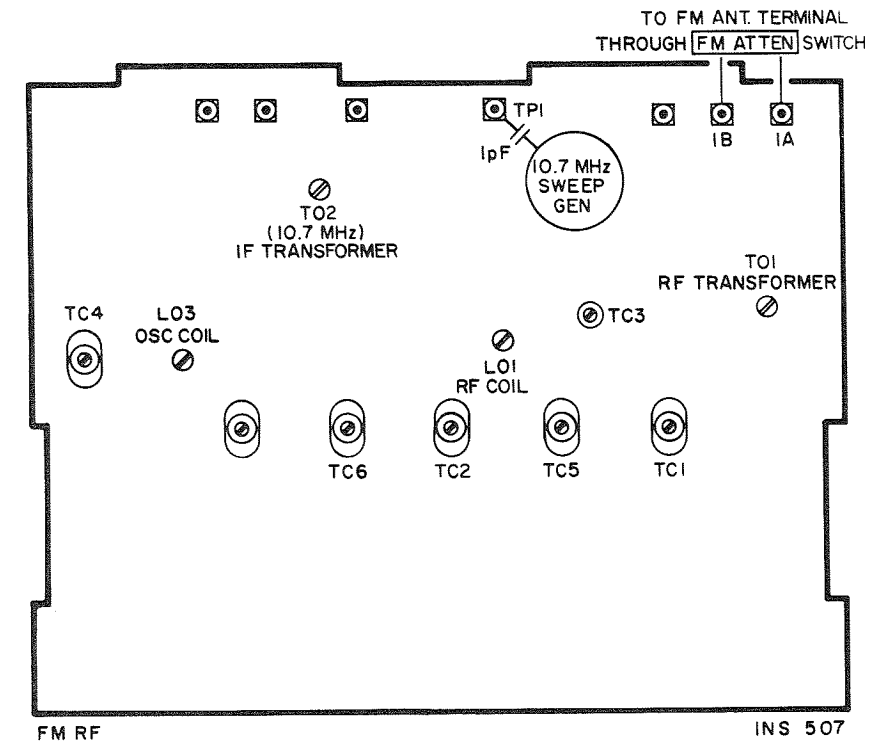
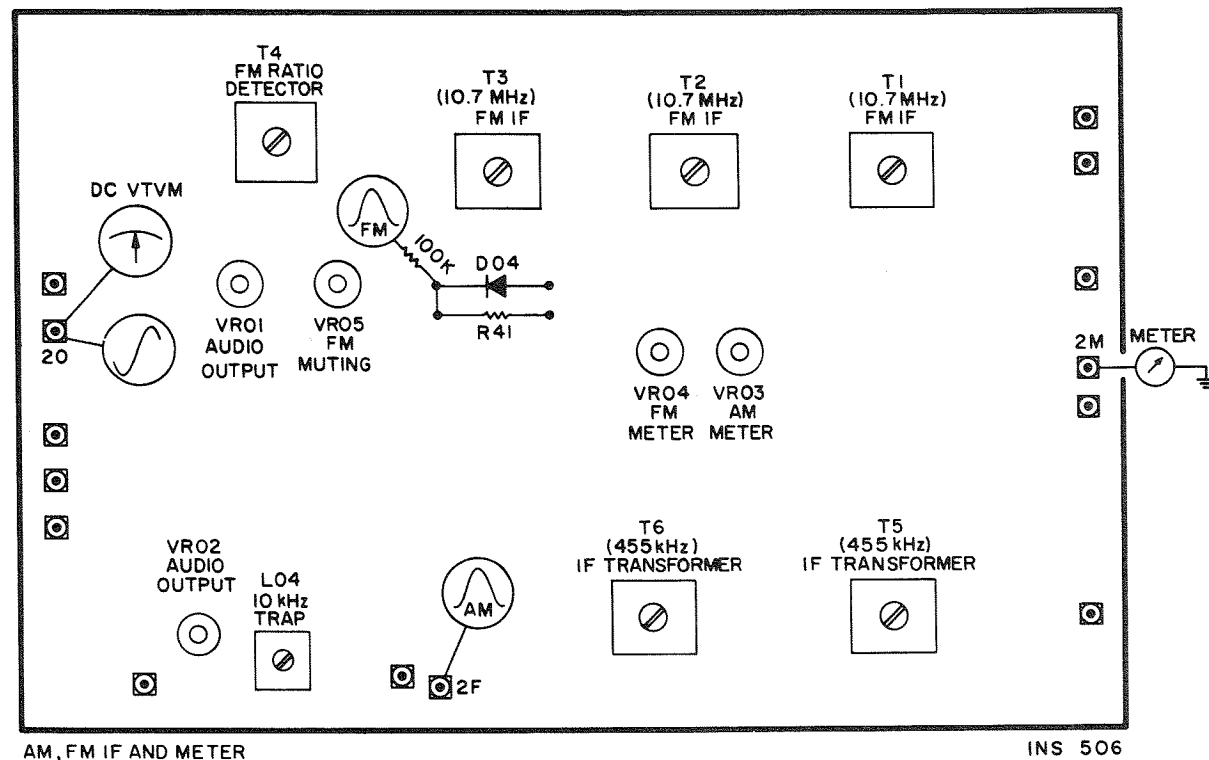

fm if

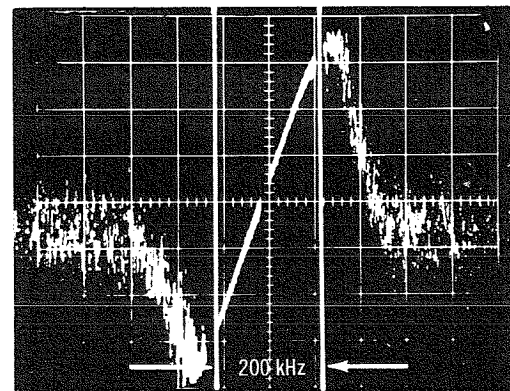

fm detector

FM ALIGNMENT

- (1) Set SELECTOR switch to FM. Turn VOLUME control to minimum (0). Set VOLUME NORMAL-LOW switch to NORMAL. Set FM ATTEN switch to NORMAL. Set FM ATTEN switch to NORMAL.
- (2) Connect the output of a 10.7 MHz sweep generator through a 1 pF capacitor to test point TP1 on the FM RF Board and the ground lead of the generator to chassis ground.
- (3) Connect oscilloscope vertical input through a 100K, 1/2 watt resistor to the junction of resistor R41 (3.3K) and diode D04 on the AM, FM IF, and Meter Board, and the ground lead of the oscilloscope to chassis ground.
- (4) Using a generator output level as low as possible, adjust top and bottom cores of T02 on the FM RF Board and top and bottom cores of transformers T1, T2, and T3 on the AM, FM IF, and Meter Board for maximum gain and symmetry as shown on oscilloscope display. See FM IF illustration.
- (5) On the AM, FM IF, and Meter Board, connect an oscilloscope between terminal 20 and chassis ground, and adjust the bottom core of T4 first, then the top core for maximum gain and symmetry on the oscilloscope display. See FM DETECTOR illustration.
- (6) Disconnect 10.7 MHz sweep generator and oscilloscope.
- (7) Connect an FM signal generator to the FM ANT terminals through two 120-ohm composition resistors, one in series with each lead of the generator. Connect an oscilloscope and AC VTVM between L RCDR OUT jack and chassis ground.
- (8) Set generator frequency and receiver's dial pointer accurately to 90 MHz. Modulate the generator with 400 Hz \pm 75 kHz deviation. Reduce generator output until noise interference is visible on sine wave displayed on oscilloscope. Adjust generator frequency to center noise interference on positive and negative half-cycles. See SYMMETRICAL TUNING illustration. On the FM RF Board adjust core of

- oscillator coil L03, or on boards without adjustable cores expand or compress turns for maximum indication on the receiver's tuning meter. Adjust transformer T01 and coil L01 for maximum signal as indicated on AC VTVM.
- (9) Set the generator frequency and the receiver's dial pointer accurately to 106 MHz. Readjust generator output until noise interference is visible on sine wave displayed on oscilloscope. Adjust generator frequency to center noise interference on positive and negative half-cycles. See SYMMETRICAL TUNING illustration. On the FM RF Board adjust oscillator trimmer capacitor TC4 and RF trimmer capacitors TC1 and TC2 for maximum audio as indicated on AC VTVM.
- (10) Repeat steps (8) and (9) for accurate dial calibration and maximum audio indicated on AC VTVM.
- CAUTION:** The neutralization adjustment procedure described in step (11) should be performed only if the field effect transistor FET01 has been replaced, or if receiver's tuning meter indicates with no signal input.
- (11) Disconnect FM signal generator and connect a 270-ohm resistor across receiver's FM ANT terminals. Tune receiver to high end of dial. Adjust trimmer capacitor TC3 on the FM RF Board so that receiver's tuning meter indicates no reading with no signal input. Disconnect 270-ohm resistor and reconnect FM signal generator to FM ANT terminals.
- (12) Set FM signal generator frequency to 100 MHz, 2 mV output level, and on AM, FM IF, and Meter Board adjust FM Meter potentiometer VR04 so that the receiver's tuning meter indicates between 4 and 4.5.
- (13) Modulate generator with 400 Hz, \pm 22.5 kHz deviation, and adjust FM Audio Output potentiometer VR01 for a 350 mV indication on AC VTVM connected to the L RCDR OUT jack.
- (14) Set generator frequency to 90 MHz at an output level of 1 mV. Connect MPX generator composite output to FM

- signal generator EXTERNAL MODULATION input. Modulate with 19 kHz \pm 7.5 kHz deviation (10% pilot, no audio). Set MODE MONO-STEREO switch to STEREO.
- (15) On MPX Board connect a DC VTVM to test point TP3. Adjust transformers T1 and T2 for maximum DC output as indicated on DC VTVM.
- (16) Modulate FM generator with 1000 Hz left and 19 kHz \pm 7.5 kHz deviation.
- (17) Connect AC VTVM and oscilloscope between test point TP2 and chassis ground. Adjust transformer T3 for maximum output with straight baseline as shown on oscilloscope display.
- (18) Connect AC VTVM and oscilloscope to L RCDR OUT jack. Note the reading on the AC VTVM, then connect the AC VTVM to R RCDR OUT jack. Adjust Separation Control potentiometer VR2 for maximum separation.
- (19) Modulate right channel with 1000 Hz and 19 kHz \pm 7.5 kHz deviation. Recheck separation, and readjust Separation Control potentiometer VR2, if necessary, so that best separation, left to right and right to left is achieved.
- (20) Set Stereo Trigger Potentiometer VR1 to minimum.
- (21) Set FM signal generator to 90 MHz at an output level of 1 mV. Modulate with 19 kHz \pm 6 kHz deviation. Set MODE MONO-STEREO switch to MONO. Connect oscilloscope between the positive terminal of capacitor C9 and ground. Adjust coil L3 for minimum output.
- (22) Modulate signal generator with 67 kHz. Increase deviation until signal output appears on the oscilloscope. Adjust coil L2 for minimum output.
- (23) Modulate signal generator with 71 kHz. Increase deviation until signal output appears on the oscilloscope. Adjust coil L2 for minimum output.
- NOTE:** Steps (22) and (23) require the use of a high-sensitivity oscilloscope.

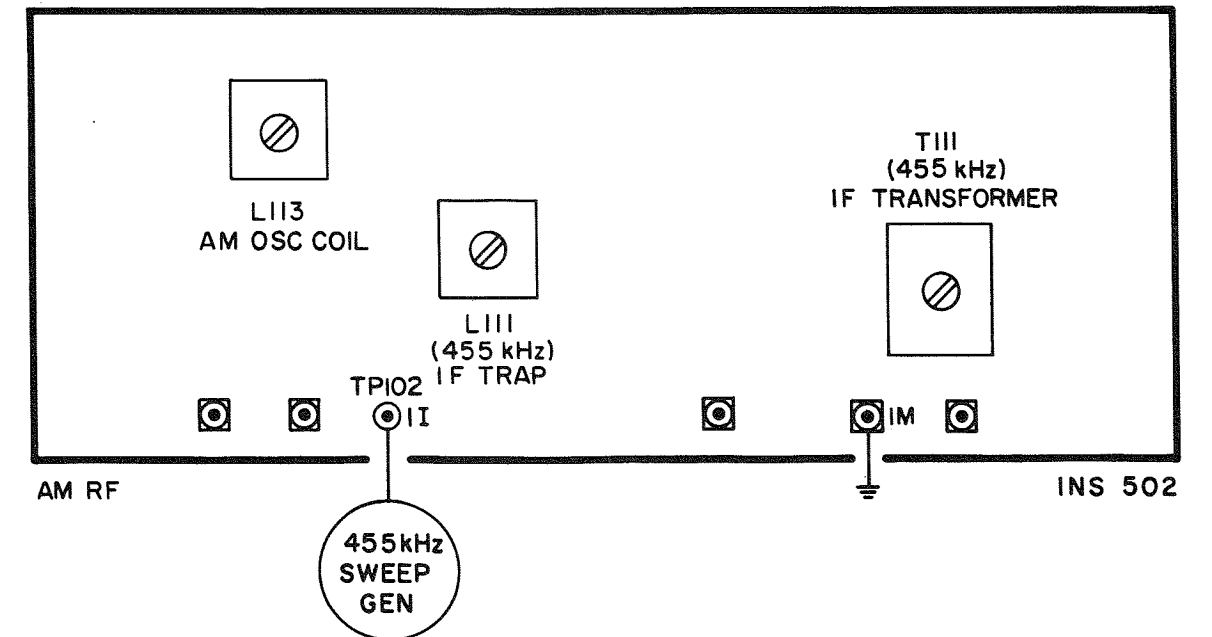
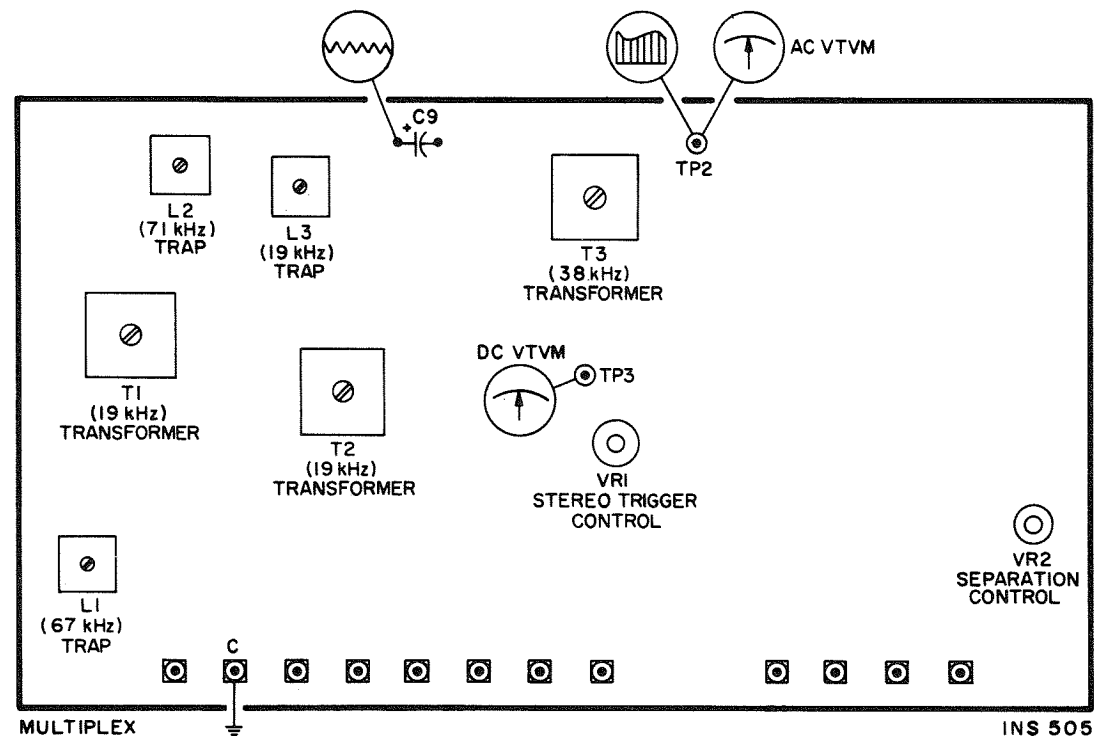

(24) Set FM signal generator frequency to 90 MHz at an output level of 10 μ V. Modulate with 19 kHz \pm 6.5 kHz deviation. Adjust Stereo Trigger Potentiometer VR1 so that STEREOBEAM lamp goes on for an FM signal generator output level between 7 μ V and 12 μ V.
 (25) Disconnect FM signal generator, AC VTVM, and oscilloscope.

AM ALIGNMENT

- (1) Set SELECTOR switch to AM and VOLUME control to minimum (0).
- (2) Connect a 455 kHz sweep generator between terminal 11 (TP102) on the AM RF Board and chassis ground. Maintain a low output level through AM alignment procedures.
- (3) Connect oscilloscope input between terminal 2F on the AM, FM IF, and Meter Board and chassis ground. Adjust sweep generator output until a pattern is visible on the scope.
- (4) Detune coil L111 on the AM RF Board for maximum output at terminal 2F.
- (5) Adjust top and bottom cores of transformer T111 on the AM RF Board and transformers T5 and T6 on the AM, FM IF, and Meter Board for maximum gain and symmetry.
- (6) Readjust coil L111 on the AM RF Board for minimum output at terminal 2F.
- (7) Disconnect the 455 kHz sweep generator and oscilloscope.
- (8) Connect an AM signal generator between EXT AM ANT and GND terminals through a 220 pF capacitor connected between EXT AM ANT terminal and generator. Connect an oscilloscope and AC VTVM between L RCDR OUT jack and chassis ground.

NOTE: During the following alignment procedure maintain generator output level for a receiver's tuning meter indication of approximately 2.5.

- (9) Set the signal generator frequency and the receiver's dial pointer to 600 kHz. Modulate the generator with 400 Hz, 30% modulation. Adjust AM RF Board coil L113 for maximum audio indication on AC VTVM. Remove tape from ferrite antenna and move antenna slide lever to obtain maximum indication on AC VTVM. Tape antenna slide lever in place.
- (10) Set the signal generator frequency and the receiver's dial pointer to 1400 kHz. Adjust oscillator trimmer capacitor TC5 and RF trimmer capacitor TC6 located on top of tuning capacitor on the FM RF Board for maximum audio output as indicated on AC VTVM.
- (11) Repeat steps (9) and (10) for accurate dial calibration and maximum gain.
- (12) Connect an audio oscillator through a 0.1 μ F capacitor to base of transistor T05 (junction of R36 and R37) on the AM, FM IF, and Meter Board. Set audio oscillator frequency to 10,000 Hz and adjust output level for an indication on AC VTVM connected to L RCDR OUT jack. On the AM, FM IF, and Meter Board adjust 10 kHz Trap Coil L04 for minimum indication on AC VTVM. Disconnect audio oscillator.
- (13) Set the AM signal generator frequency to 1000 kHz at an output level of 90 μ V. Modulate the generator with 400 Hz, 30% modulation. On the AM, FM IF, and Meter Board adjust AM Meter potentiometer VR03 for an indication of 1 on the receiver's tuning meter.
- (14) Set the signal generator frequency to 1000 kHz at an output level of 10 mV. On the AM, FM IF, and Meter Board, adjust AM Output potentiometer VR02 for 350 mV indication on AC VTVM connected to the L RCDR OUT jack.
- (15) Disconnect the test equipment.

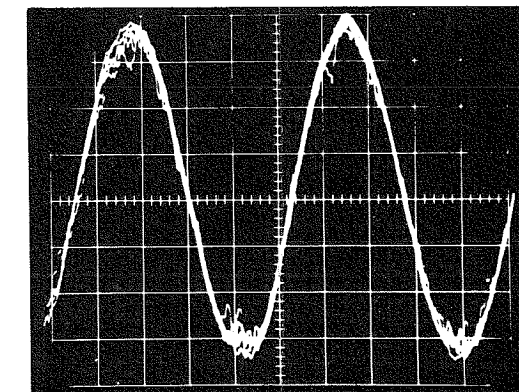

fm symmetrical tuning

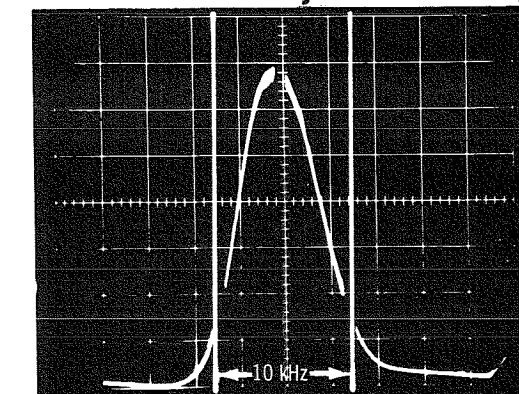

am if

16 AM RF

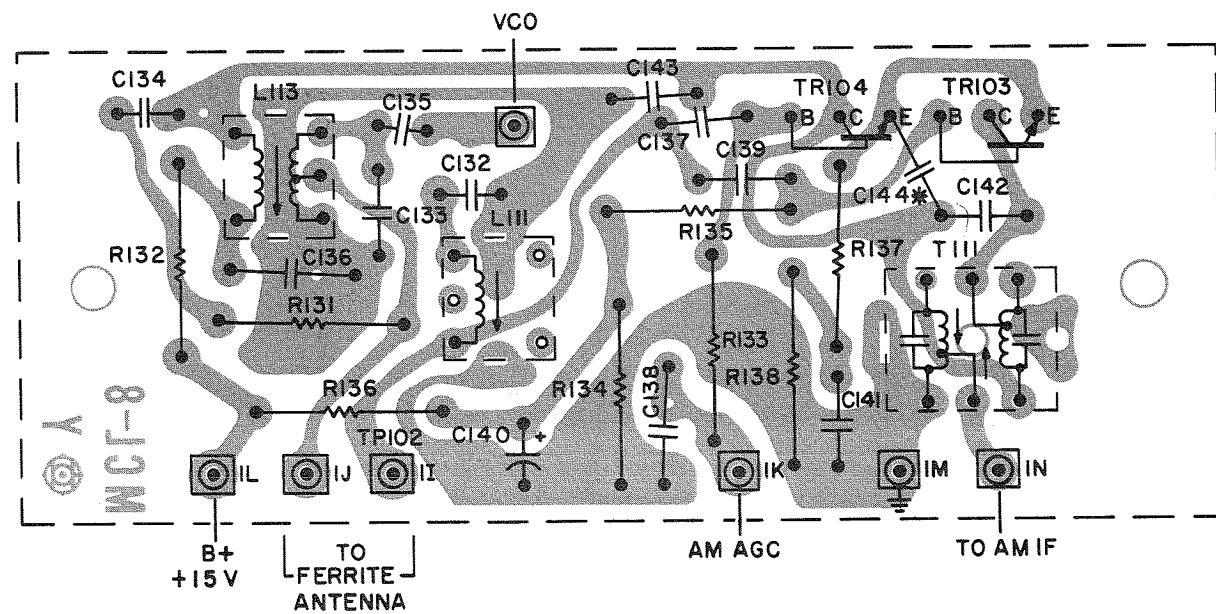
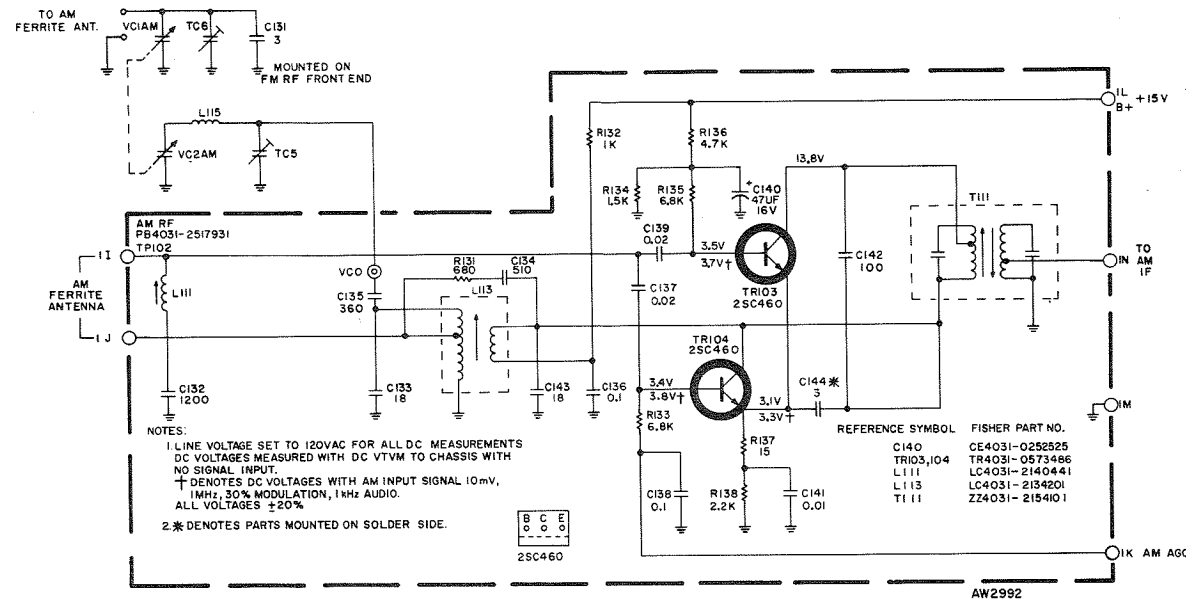

AL4031-04

COMPONENT CONNECTIONS

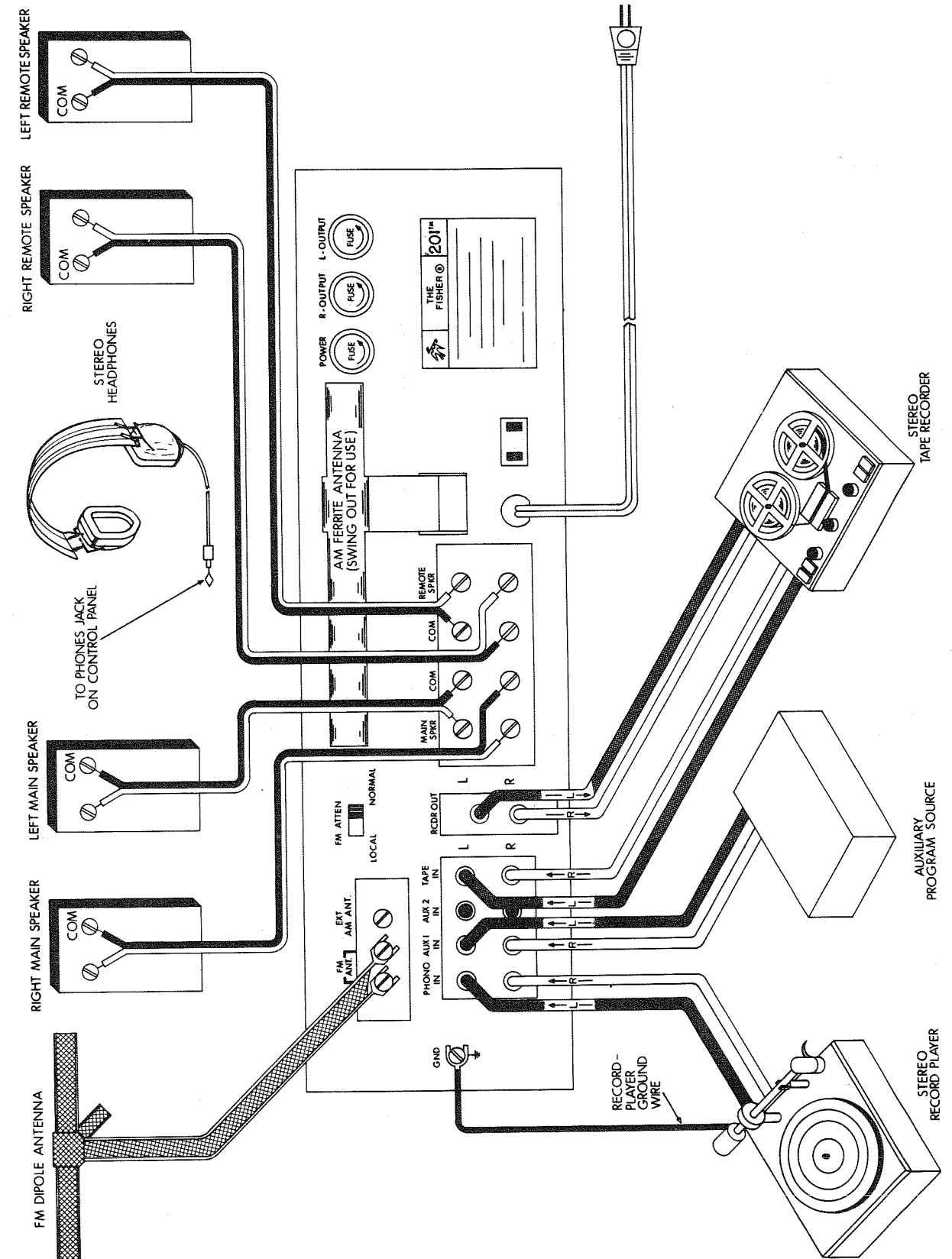

BECAUSE ITS PRODUCTS ARE SUBJECT TO CONTINUOUS IMPROVEMENT, FISHER RADIO RESERVES THE RIGHT TO MODIFY ANY DESIGN OR SPECIFICATION WITHOUT NOTICE AND WITHOUT INCURRING ANY OBLIGATION.

FISHER RADIO • LONG ISLAND CITY • NEW YORK 11101