

THIS MANUAL ALSO COVERS THE
213 AND 295 RECEIVERS

SERVICE MANUAL

PRICE \$1.00

203

SERIAL NUMBERS
BEGINNING 10001

The Fisher® 203



**Stereophonic
AM-FM Receiver**

WORLD LEADER IN HIGH QUALITY STEREO

	Page		Page
TEST EQUIPMENT	2	AM RF	8
MECHANICAL DISASSEMBLY	3	FM RF	9
DIAL STRINGING	3	AM-FM IF	10
HARMONIC DISTORTION TEST	3	MULTIPLEX	12
SIGNAL FLOW	4	PREAMP AND SELECTOR SWITCH	14
CHASSIS LAYOUT	5	CONTROL AMP	16
TUNER ALIGNMENT	6	POWER AMP-POWER SUPPLY	18

CAUTION:

This precision high-fidelity instrument should be serviced only by qualified personnel, trained in the repair of transistor equipment and printed circuitry.

Many of these items are included only as a reminder — they are normal procedures for experienced technicians. Shortcuts may be taken, but these often cause additional damage to transistors, circuit components, or printed circuit boards.

SOLDERING: A well-tinned, hot, clean soldering iron tip will make soldering easier, without causing damage to the printed circuit board or the components mounted on it. Regular use of a sponge cleaner will maintain a clean soldering surface. The heat available at the tip, (not the wattage of the iron) is important. Some 50-watt irons reach temperatures of 1,000° F, while others will hardly melt solder. Small-diameter tips should be used for single solder connections, pyramid and chisel tips for large areas.

Always disconnect the AC power cord from the line when soldering. Turning the power switch OFF is not sufficient. Power-line leakage paths, through the heating elements of the iron, may destroy transistors.

PARTS REMOVAL: If a part is not being returned for in-warranty factory replacement, it may be cut in half (with diagonal cutting pliers) to make removal easier. Multiple terminal parts, such as IF transformers, or electrolytic capacitors, should be removed using special de-soldering tips made especially for this purpose. Removing solder from terminals, reduces the possibility of breaking the printed circuit board when the part is removed.

ACCIDENTAL SHORTS: A clean working area, free of metal particles, screws, etc., is an important preventive in avoiding servicing problems. Screws, removed from the chassis during servicing, should be stored in a box until needed. While a set is operating, it takes only an instant for a base-to-collector short to destroy a transistor (and others direct-coupled to it). In the time it takes for a dropped screw, washer, or screwdriver, to contact a pair of terminals (or terminal and chassis), a transistor can be ruined.

SOLID-STATE DEVICES: Integrated Circuits contain the equivalent of many circuit parts, including transistors, diodes, resistors, and capacitors. The preferred troubleshooting procedure requires isolating the trouble to one stage using AC signal tracing methods. Once the suspected stage is located the DC voltages at the input and output leads are measured to give an accurate indication of the operating conditions of the IC. DO NOT use an ohmmeter, to check continuity with the IC mounted on the printed circuit board. Forward biasing the internal junctions within the IC may burn out the transistors. Do not replace a defective IC until all external resistors, capacitors, and transformers are checked first, to prevent the replacement IC from failing immediately due to a defect in the connecting components. Solder and unsolder each lead separately using a pliers or other heat sink on the lead to

prevent damage from excessive heat. Check that the leads are connected to the correct locations on the printed circuit board before turning the set on.

Whenever possible, a transistor tester should be used to determine the condition of a transistor or diode. Ohmmeter checks do not provide conclusive data, and many even destroy the junction(s) within the device.

Never attempt to repair a transistor power amplifier module until the power supply filter-capacitors are fully discharged.

If an output or driver transistor becomes defective (opens or shorts), always check ALL direct-coupled transistors and diodes in that channel. In addition, check the bias pot., and other parts in the bias network, before installing replacement transistors. All output and driver transistors in one channel may be destroyed if the bias network is defective. After parts replacement, check bias for specified idling current.

In some applications, replacement of transistors must be made from the same beta group as the original type. The beta group is indicated by a colored marking on the transistor. Include this information when ordering replacements.

When mounting a replacement power transistor, be sure the bottom of the flange, mica insulator, and the surface of the heat sink, are free of foreign matter. Dust and grit will prevent flat contact, reducing heat transfer to the heat sink. Metallic particles can puncture the insulator, cause a short, and destroy the transistor.

Silicone grease must be used between the transistor and the mica insulator and between the mica and the heat sink for best heat transfer. Use Dow-Corning DC-3, or an equivalent compound made for power transistor heat conduction.

Use care when making connections to speakers and output terminals. To reduce the possibility of shorts, lugs should be used on the exposed ends, or stranded wire should be tinned to prevent frayed wire ends. Current in the speakers and output circuitry is quite high — poor contacts, or small wire, can cause significant power losses. For wire lengths greater than 30 feet, 16 AWG, or heavier, should be used.

VOLTAGE MEASUREMENTS: All voltages are measured with the line voltage adjusted to 120 volts. All measured voltages are $\pm 20\%$. DC voltages are measured to chassis with a VTVM, with no signal input unless otherwise noted. AC signal voltages are measured under the conditions specified on the schematic.

ALIGNMENT PROCEDURES: DO NOT attempt realignment unless the required test equipment is available, and the alignment procedure is thoroughly understood.

The following equipment is required to completely test and align the 205 AM-FM Receiver.

- Line Voltage Autotransformer or Voltage Regulator
- DC Vacuum Tube Voltohmmeter
- Accurately Calibrated AC Vacuum Tube Voltmeter
- Oscilloscope (Flat to 100 KHz Minimum)
- Low-Distortion Audio (Sine Wave) Generator
- Harmonic Distortion Analyzer
- 2 — Load resistors, 4-Ohms, 100 Watt (Minimum Rating)
- AM/FM Signal Generator
- 10.7 MHz Sweep Generator (Fisher 3024*)
- Multiplex Generator (Fisher 1536*)
- 455 KHz Sweep Generator (Fisher 3025*)
- Stereo Source — Turntable, Tape Recorder, etc.
- Soldering Iron with Small Tip, Fully Insulated from AC Line
- Suction Desoldering Tool

*with Power Supply (Fisher 1561)

REMOVING DRESS PANEL

- (1) Remove screws securing top and bottom covers to chassis. Remove covers.
- (2) Gently pull POWER/SPKRS, BASS, MIDRANGE, TREBLE, BALANCE, VOLUME, SELECTOR, and TUNING knobs from their control shafts.
- (3) Remove three screws on top and three screws on bottom securing dress panel to chassis. Remove dress panel by pulling it forward.
- (4) Reverse procedure for reassembly.

REPLACING DIAL GLASS

CAUTION: Dial glass is made of plastic and scratches easily.

- (1) Remove screws securing top and bottom covers to chassis. Remove covers.
- (2) Remove dress panel.
- (3) Rotate tuning knob fully counterclockwise so that dial pointer is at 0 on logging scale.
- (4) Remove dial cord from tabs on dial pointer assembly and slide assembly off rail at notch. Do not disconnect wiring.
- (5) Remove two screws securing top dial glass retaining bracket to dial pointer rail. Remove bracket.
- (6) Gently pry dial glass from dress panel. (Glass is held with double-sided adhesive tape.) Take care not to damage the foam rubber mountings.
- (7) Reverse procedure for reassembly. Position dial pointer at 0 on logging scale.

REPLACING SIGNAL METER

- (1) Remove screws securing top cover to chassis. Remove cover.
- (2) Remove screws securing meter lamp assembly to flange on dial panel.
- (3) Remove meter leads and label for reference.
- (4) Gently pry meter from back of dial panel and scrape residual adhesive from panel.
- (5) Peel backing from one side of replacement mounting pad and affix it to replacement meter. Peel backing from other side of pad, align meter face behind panel cutout, and press meter firmly to back of panel.
- (6) Reconnect meter leads.
- (7) Install meter lamp assembly.

REPLACING DIAL LAMPS

- (1) Remove screws securing top cover to chassis. Remove cover.
- (2) Loosen, but do not remove screws securing IF shield to dial lamp bracket. Remove shield.
- (3) Remove loosened screws and rotate dial lamp assembly bracket to expose dial lamps on lamp board.
- (4) Snap out defective lamp and insert new lamp.
- (5) Reassemble in reverse order.

REPLACING STEREOBEACON LAMPS

- (1) Remove screws securing top cover to chassis and remove cover.

- (2) Remove defective lamp by pulling out of lampholder.
- (3) Unsolder leads and remove defective lamp.
- (4) Install new lamp in reverse order.

REPLACING METER LAMPS

- (1) Remove screws securing top cover to chassis. Remove cover.
- (2) Remove screws securing meter lamp assembly to flange on dial panel.
- (3) Snap out defective lamp and insert new one.
- (4) Install meter lamp assembly.

REPLACING DIAL POINTER

- (1) Remove screws securing top cover to chassis. Remove cover.
- (2) Loosen but do not remove screws holding IF shield to dial lamp assembly bracket. Remove shield.
- (3) Unsolder dial pointer leads from pins 12Q and 12O of lamp holder circuit board.
- (4) To remove defective lamp, pull out of lampholder. To remove pointer assembly rotate tuning knob fully counterclockwise so that dial pointer is at 0 on logging scale.
- (5) Remove dial cord from tabs on pointer assembly and slide pointer off the rail.
- (6) Replace dial pointer using reverse procedure.

REMOVING PC BOARDS

To remove most printed circuit boards, disconnect leads, squeeze nylon PCB holder and lift board straight up. Label all wires for reference. Several boards have ground connections to the chassis, front panel controls, or require additional removal procedures as follows:

CONTROL AMPLIFIER BOARD

- (1) Remove screws securing top and bottom covers to chassis. Remove covers.
- (2) Remove dress panel.
- (3) Disconnect all wiring to board and label for reference.
- (4) Remove four screws that secure potentiometer bracket to front panel. Remove entire assembly including POWER/SPKRS switch.
- (5) Install circuit board in reverse order.

AM-FM IF BOARD

- (1) Loosen but do not remove screws holding IF shield to dial lamp bracket. Remove shield.
- (2) Disconnect all wiring and label for reference. There are four connections to chassis ground.
- (3) Squeeze nylon PCB holder and lift board straight up.
- (4) Install circuit board in reverse order.

FM RF BOARD

- (1) Remove shield cover from underside of chassis.
- (2) Unsolder three chassis ground connections and the FM antenna leads. Disconnect other wires. Label all wires for reference.
- (3) Remove dial cord from drum. Unsolder shields from chassis from two points at top of board. Disconnect wires from tuning capacitor. Label all wires for reference.
- (4) Remove screws securing circuit board and lift straight up.
- (5) Install board in reverse order.
- (6) Restraining dial cord. Refer to DIAL STRINGING.

PLEASE READ CAREFULLY: The parts lists on this and following pages do not include shipping charges. Please include the serial number of the Fisher equipment for which the part(s) are intended. Send your order to: PARTS DEPARTMENT, FISHER RADIO, 11-40 45th Road, Long Island City, N.Y. 11101.

MAIN CHASSIS

Symbol	Description	Part No.	Sug. Ret.
—	AC Outlet	JK4083-2657051	.75
—	Antenna, Ferrite (AM)	LA4083-2134214	4.60
—	Antenna Holder Assembly (AM)	AS4083-3910252	1.05
—	Cover, Top	AS4083-4358773	12.50
—	Cover, Bottom	AS4083-4364473	10.95
—	Cover, Protective (Transistor)	EM4083-3914401	.60
—	Cushion, Meter	EM4083-4681801	.45
—	Dial Glass Assembly (Acrylic)	AS4084-3915042	7.30
—	Dial Pointer Assembly (with lamp)	AS4083-3386441	4.35
—	Dial Pulley	EM4083-3915651	1.50
—	Dress Panel Assembly (205)	AS4084-3241462	30.00
—	Dress Panel Assembly (215)	AS4084-3241466	30.00
—	Fuseholder	EM4083-2727062	1.45
—	Holder, PCB	EM4083-3715321	.45
—	Insulator, AC Outlet	EM4083-3910501	.75
—	Jack Strip, TAPE IN, RCDR OUT (4 jacks)	ET4083-2677141	1.45
—	Jack Strip, PHONO, AUX (6 jacks)	ET4083-2677131	2.40
—	Jack, PHONES, RCDR OUT	JK4083-2677061	1.60
—	Jack/Plug, Voltage Selector	JK4083-2657121	4.00
—	Knob 205:		
—	Tuning Small	EK4083-3280791	1.90
—	Knob 215:	EK4083-3280802	1.45
—	Tuning Small	EK4083-3280792	1.90
—	Knob 215:	EK4083-3280803	1.45
—	Lampholder Assembly	AS4084-4681811	3.10
—	Lamp, Dial Pointer (60mA, 5V)	LM4084-2767094	1.65
—	Lamp, PHONO, AM, FM, AUX (65mA, 6.3V)	LM4084-2767115	1.35
—	Lamp, Dial, Meter, Fuse Type (250mA, 6.3V)	LM4083-2767201	1.15
—	Lamp, STEREOBEACON (25mA, 5V)	LM4083-2767081	1.65
—	Meter, Center-of-Channel	MC4084-2577121	7.20
—	Meter, Signal	MC4083-2577122	7.20
—	PCB, FM RF	PB4083-2518701	26.10
—	PCB, AM RF	PB4083-2517932	12.25
—	PCB, AM-FM IF	PB4083-2518801	60.10
—	PCB, Multiplex	PB4083-2517944	46.05
—	PCB, Preamplifier	PB4084-2518711	12.95
—	PCB, Control Amplifier	PB4083-2518741	43.70
—	PCB, Power Amplifier-Power Supply	PB4084-2518731	67.20
—	PCB, Dial Lamp	PB4083-2518571	3.55
—	Power Cord	W4084-2740241	2.10
—	Screw, Ground	HS4042-4513311	.40
—	Shield, IF	AS4083-4371441	1.20
—	Socket, Transistor	ES4031-2650113	.70
—	Switch, Lever	SU4083-2637171	1.65
—	Switch, Rotary, POWER/SPKRS	SR4083-2617133	5.55
—	Switch, Rotary, SELECTOR	SR4031-2617062	7.65
—	Switch, Slide, FM ATTEN, PHONO	SS4031-2627012	.85
—	Terminal Strip, Antenna	ET4083-2681353	1.30
—	Terminal Strip, Speakers	ET4083-2687321	3.10
—	Tuning Shaft Assembly	AS4083-4368722	8.60
—	Transformer, Power, 120V	TD4083-2217441	33.00
—	*Transformer, Power, Multi-voltage	TE4083-2217442	39.00
C1, 2	Electrolytic, 2000uF, 50V	CE4083-0259757	4.25
C3	Electrolytic, 2200uF, 90V	CE4083-0259799	7.55
C4	Ceramic, 4700pF, 150VAC	CK4042-0243873	.95
C5	Electrolytic, 220uF, 16V	CE4042-0252532	.90
C6	Mylar, 4700pF, 50V	CY4083-1274015	.40
C7	Electrolytic, 100uF, 16V	CE4031-0252531	.70
F1	Line Fuse, 2A, 125V, Slo-Blo	FL51313-2	.75
*F1	Line Fuse, 1A, 250V, Slo-Blo	FL51313-3	.80
F2, 3	Output Fuse, 2A, 125V	FL51313-29	.75
F4	Lamp Fuse, 3A, 125V, Pigtail	FL4084-2727085	.75
L1, 2	RF Choke, 27uH	LC4031-2227035	.60
R1, 2	Film, 3.3K, 5%, 1/4W	RF25DC332J	.30
R3	Film, 330, 5%, 1/4W	RF25DC331J	.30
R4, 5	Composition, 470, 10%, 1/4W	RC20BF471K	.35
R6, 7	Film, 680, 5%, 1/4W	RF25DC681J	.30
R8	Film, 18, 5%, 1/4W	RF25DC180J	.30
R9	Composition, 2.7M, 10%, 1/4W	RC20BF275K	.35
Q1, 2, 3, 4	Transistor, 2SC1030B	TR4031-2327052	7.90

*Denotes components used in export units only
PRICES SUBJECT TO CHANGE WITHOUT NOTICE

- (1) Remove top cover from chassis.
- (2) Rotate tuning capacitor fully clockwise (capacitor fully closed).
- (3) Tie one end of dial cord around lower left ear on drum. See illustration.
- (4) Run dial cord over the left drum ear and through rim slot onto groove 1. Guide cord around pulleys 'A' and 'B,' back under pointer guide bracket, and over pulley 'C.'
- (5) Wrap 3½ turns clockwise around tuning shaft (as viewed from rear).
- (6) Guide cord around pulley 'D.' Keep cord taut and rotate tuning capacitor fully open while allowing dial cord to wind on drum.
- (7) Guide cord over groove 3 on drum and wrap one full turn around drum to top of groove 4.
- (8) Guide cord around tension pulley and back onto drum at the bottom of groove 4.
- (9) Wrap cord one-half turn around drum to end of groove 5, hook around upper tie post on inside of drum, and tie securely to lower tie post.
- (10) Rotate drum clockwise and counterclockwise to distribute tension. Repeat several times so that spring becomes tensioned.
- (11) Rotate tuning knob counterclockwise so that tuning capacitor is fully closed. Place dial cord around tabs on dial pointer assembly and slide pointer to 0 on logging scale.
- (12) Check dial calibration. Refer to TUNER ALIGNMENT.

CAUTION:

- (A) Measure one channel at a time.
- (B) Limit measurements to 10 minutes.
- (C) Use a load resistor with a minimum rating of 50 watts.

- (1) Set BASS, MIDRANGE, and TREBLE controls flat (0), SELECTOR switch to AUX 1, and POWER/SPKRS switch to AC OFF.
- (2) Connect a low-distortion sine wave signal generator between L AUX 1 IN jack and chassis ground. Set the signal generator frequency to 1000 Hz and output level to minimum.
- (3) Connect the 4-ohm load resistor between L MAIN SPKR and COM terminals. Connect an AC VTVM, oscilloscope, and harmonic distortion analyzer across the 4-ohm load resistor.
- (4) Set POWER/SPKRS switch to MAIN. Turn VOLUME control slowly to maximum.
- (5) Adjust the signal generator output until the AC VTVM indicates 10 VRMS (25W). The HD analyzer should indicate less than 1% harmonic distortion.
- (6) Repeat steps (1) through (5) for the right channel.

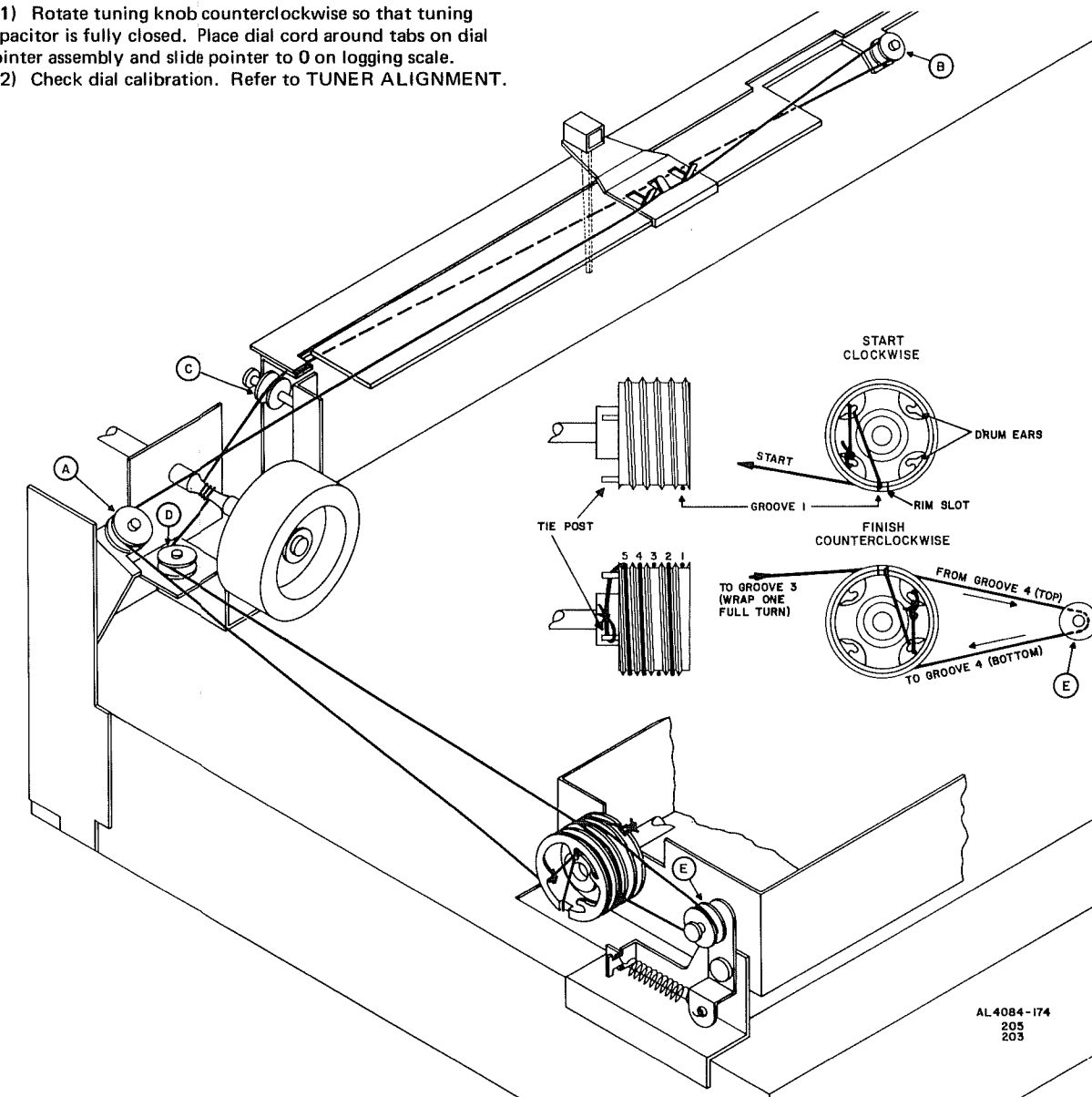

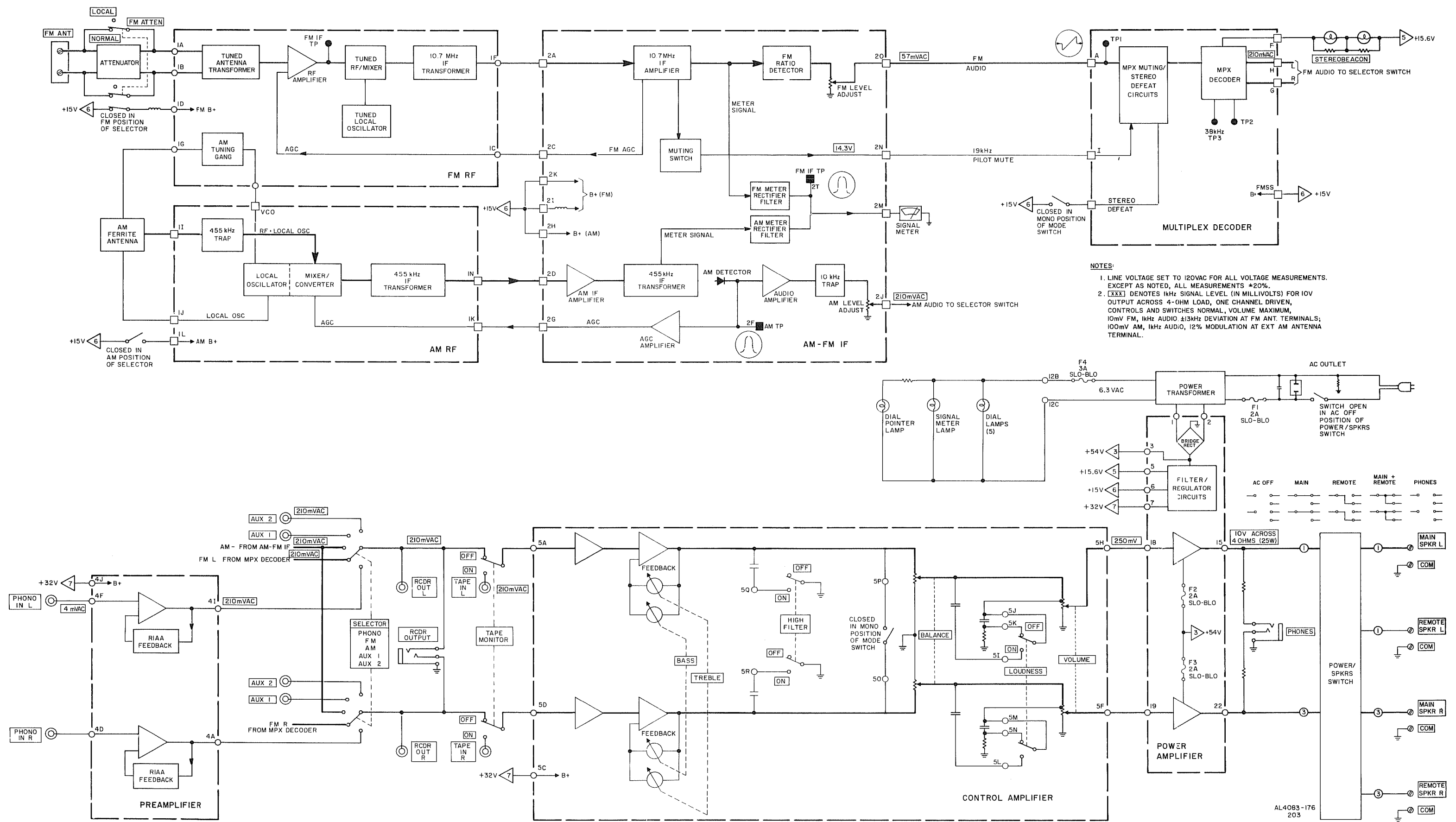

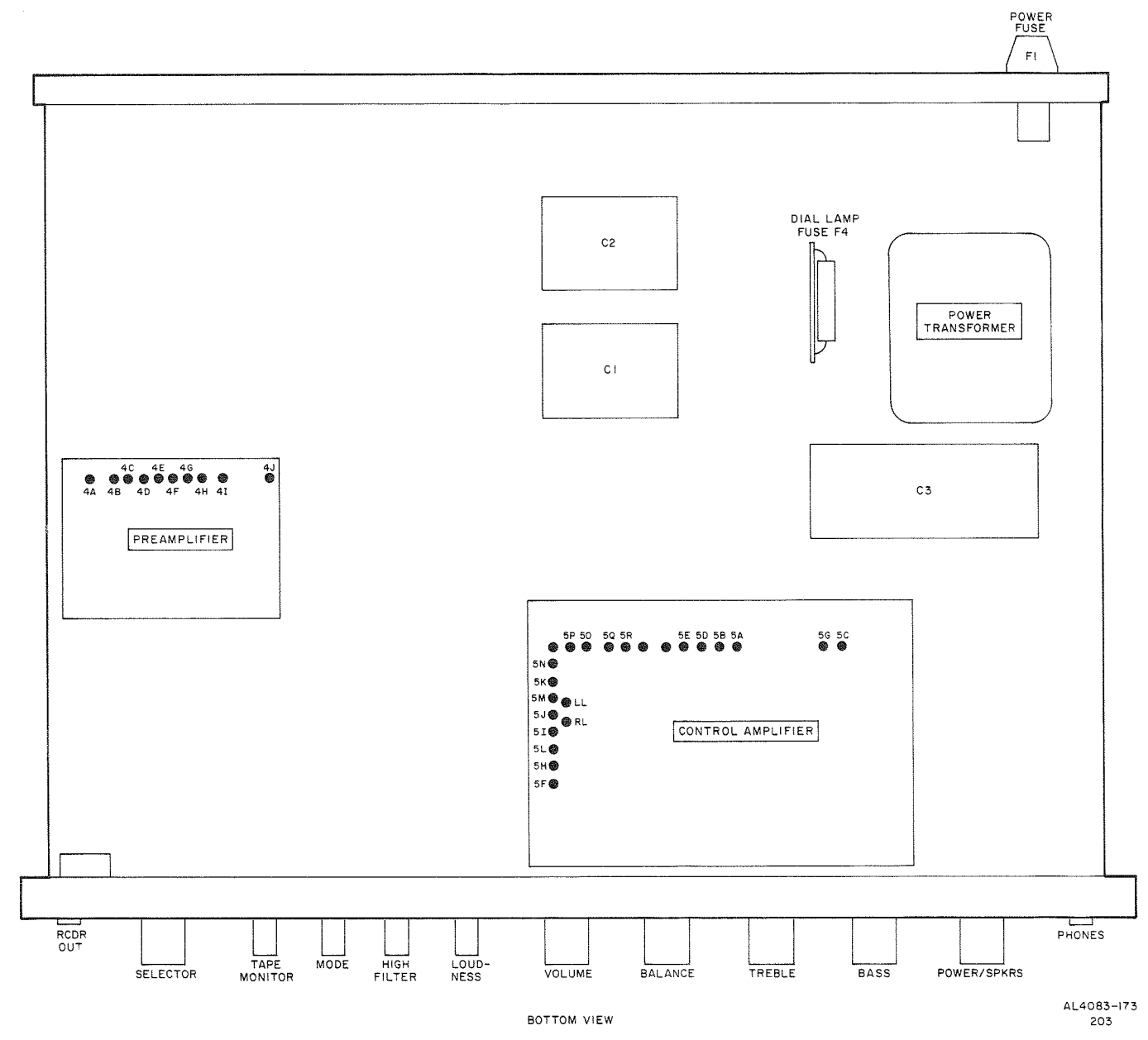
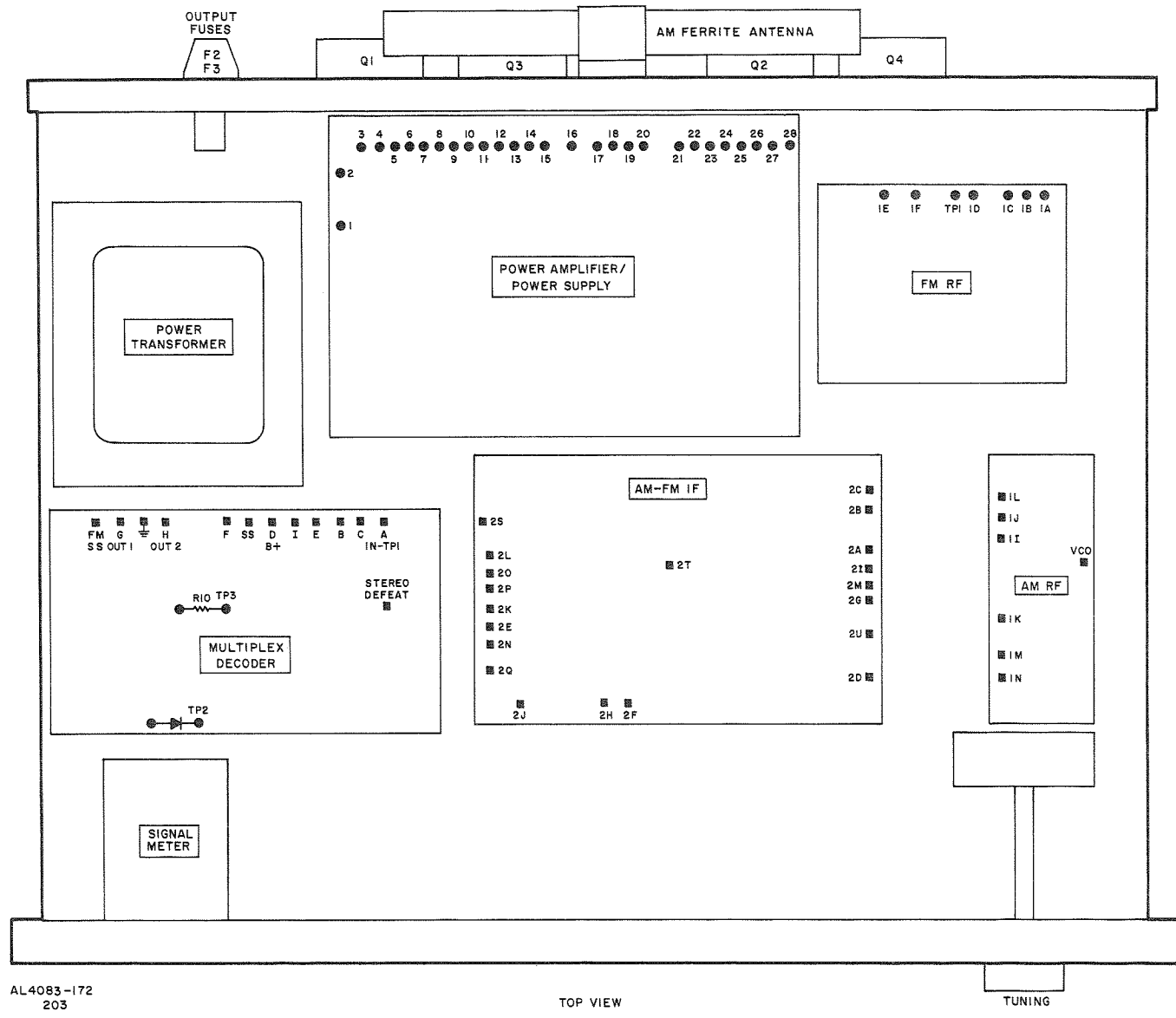

FM ALIGNMENT – SELECTOR to FM, MODE to MONO, MUTING to OFF, VOLUME to 0, FM ATTEN to NORMAL

Maintain generator output as low as possible for suitable indication.

ITEM	GENERATOR	DIAL SETTING	INDICATION	PROCEDURE
1. IF	Connect 10.7 MHz sweep through 1pF capacitor to TP1 on FM RF board, gnd to pin 1E.	Position of non-interference near 88 MHz.	Scope vert input through 100K to pin 2T on AM-FM IF board, gnd to 2B.	Detune T04 top (ratio detector). Adjust the following for max gain and symmetry: AM FM IF board – T01, T02, and T03 top and bottom. FM RF board – T02 top and bottom. See FM IF illustration.
2. DETECTOR	“	“	Scope vert input and DC VTVM to pin 20, gnd to 2L.	Set VR01 to max. Adjust T04 bottom, then top for max gain and symmetry. Use lowest VTVM scale to adjust for zero. See FM DETECTOR illustration.
NOTE: Use 120-ohm composition resistors in series with each lead from RF generator to match 50-ohm output to 300-ohm input impedances. Generator output is reduced to one-half at ant terminals. Signal voltages are generator output levels, not antenna voltages.				
3. FM RF		Tuning knob fully CCW.		Center pointer on 0 and cement.
4.	FM generator to FM ANT terminals through 120-ohm resistors. Set to 90 MHz. Set output for approx 2.5 on signal meter.	Center of 90 MHz calibration mark on dial.	Front panel signal meter.	Adjust L03, T01, and L01 on FM RF board for max meter deflection. Reduce generator output to keep meter at approx 2.5.
5.	Set to 106 MHz.	Center of 106 MHz calibration mark on dial.	“	Adjust TC1, TC2, and TC4 on on FM RF board for max meter reading. Reduce generator output to keep meter at approx 2.5. Repeat steps 4 and 5 for max gain and accurate dial calibration.
NOTE: The neutralization adjustment of step 6 should be performed only if FET 01 is replaced or the signal meter shows a reading with no signal at the input terminals.				
6.	Disconnect generator and connect a 270-ohm resistor across FM ANT terminals.	Tune to high end of dial.	“	Adjust TC3 on FM RF board for 0 reading with no signal input. Reconnect generator and repeat steps 4 and 5.
7. SIGNAL METER	FM generator to position of non-interference near 100 MHz. Set output for 2 mV.	Tune to generator.	“	Adjust VR04 on AM-FM IF board for reading between 4 and 4.5.
8. FM LEVEL	Modulate generator with 400 Hz, ±22.5 kHz deviation. Set output for 2mV.	“	AC VTVM to L RCDR OUT jack.	Adjust VR01 on AM, FM IF board for 350 mV.

ITEM	GENERATOR	DIAL SETTING	INDICATOR	PROCEDURE
9. MUTING	Modulate generator with 19 kHz, ±6 kHz deviation. Set output for 2mV.	“	STEREOBEACON lamp.	Adjust VR05 so that STEREOBEACON lamp just lights.
10.	Set generator to 90 MHz, 1 mV output. Modulate with 19 kHz, ±6 kHz deviation.	“	Scope vert input and AC VTVM to L RCDR OUT jack.	Set MODE to MONO. Adjust L3 on multiplex board for min output. on scope trace. Set MUTING to OFF.
11. 19 kHz TRAP	Set generator to 90 MHz, 1 mV output. Modulate with 19 kHz, ±6kHz deviation.	“	“	Adjust L1 on multiplex board for min output.
12. 67 kHz TRAP	Modulate generator with 67 kHz. Adjust deviation for signal visible on scope.	“	“	Adjust L2 on Multiplex board for min output.
13. 71 kHz TRAP	Modulate generator with 71 kHz. Adjust deviation for signal visible on scope.	“	“	Adjust L2 on multiplex board for min output.
14. 19 kHz PILOT	Set FM generator to 90 MHz with composite multiplex signal at EXTERNAL MODULATION input. Modulate with 19 kHz pilot, ±7.5 kHz deviation (no audio modulation).	“	DC VTVM to TP3 on multiplex board, gnd to pin C.	Set MODE switch to STEREO. Adjust T1 and T2 for max deflection on VTVM.
15. SEPARATION	Modulate generator with 19 kHz pilot (10%) 1 kHz audio (90%), left channel only. Set deviation to ±42.5 kHz.	“	Scope vert input and AC VTVM to L RCDR OUT jack, gnd to chassis.	Adjust T3 on multiplex board for max output. Note reading on VTVM.
16.	Modulate generator with 19 kHz pilot (10%).	“	AC VTVM to R RCDR OUT jack, gnd to chassis.	Adjust VR2 on multiplex board for best separation (min) on on VTVM.
17. STEREO BEACON	Set Generator to 90 MHz and set output to 10 uV. Modulate with 19 kHz pilot, ±6.5 kHz deviation (no audio).	“	STEREOBEACON light.	Adjust VR1 on multiplex board so that STEREOBEACON lamp goes on with generator output between 7uV and 12uV.

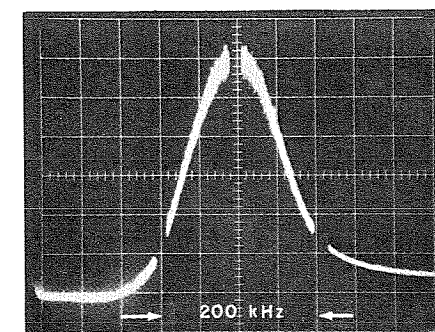

FM IF

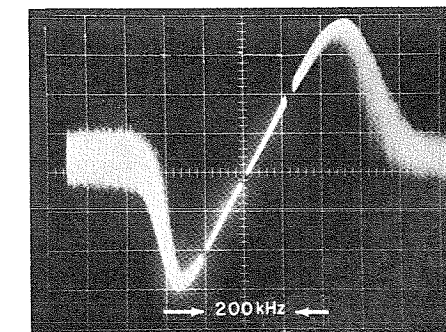

FM DETECTOR

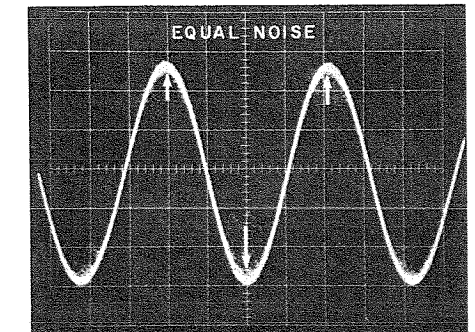

SYMMETRICAL TUNING

TUNER ALIGNMENT

AM ALIGNMENT – SELECTOR to AM, VOLUME to 0

Maintain generator output as low as possible for suitable indication.

	GENERATOR	DIAL SETTING	INDICATOR	PROCEDURE
1. IF	455 kHz sweep generator to pin 11 on AM RF board. Adjust output for pattern on scope.	Position of non-interference.	Scope vert input to pin 2F on AM-FM IF board, gnd to chassis.	Detune L111 on AM RF board. Adjust T111 top and bottom on AM RF board and T05 and T06 on AM FM IF board for max gain and symmetry. Readjust L111 for min output.
2. AM RF	AM signal generator to EXT AM ANT through 220pF capacitor. Set generator to 600 kHz. Modulate with 400 Hz, 30% modulation.	Center of 600 kHz calibration mark on dial.	Front panel signal meter.	Adjust L113 on AM RF board for max. Remove tape from ferrite antenna case and adjust slide for max signal. Retape slide in place. Reduce generator output to keep meter at approx 2.5.
3.	Set generator to 1400 kHz.	Center of 1400 kHz calibration mark on dial.	"	Adjust TC5 and TC6 on FM RF board for max signal. Repeat steps 2 and 3 for max gain and accurate dial calibration.
4. 10 kHz TRAP	Audio oscillator through 0.1uF capacitor to base of transistor Q05 on AM FM IF board. Set osc to 10 kHz.	Position of non-interference.	AC VTVM to L RCDR OUT jack.	Adjust L04 on AM FM IF board for min indication.
5.	Set generator to 1 MHz. Modulate with 400 Hz 30% modulation. Set output to 1 mV.	"	Front panel signal meter.	Adjust VR03 on AM FM IF board for meter reading between 4 and 4.5.
6.	Set generator for 10 mV output.	"	AC VTVM to L RCDR OUT jack, gnd to chassis.	Adjust VR02 on AM FM IF board for 350 mV.

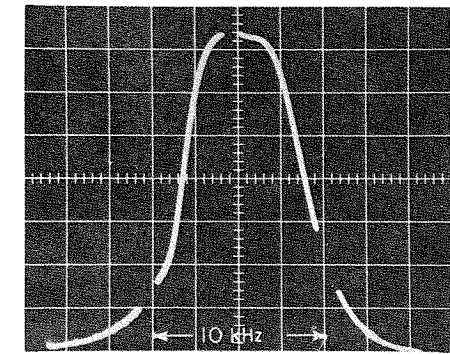

AM IF

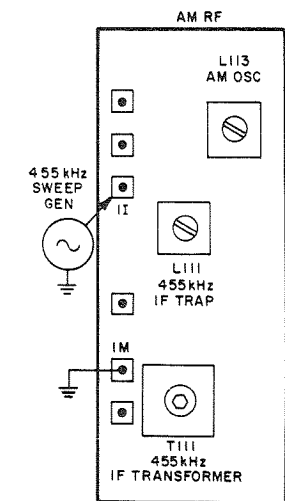
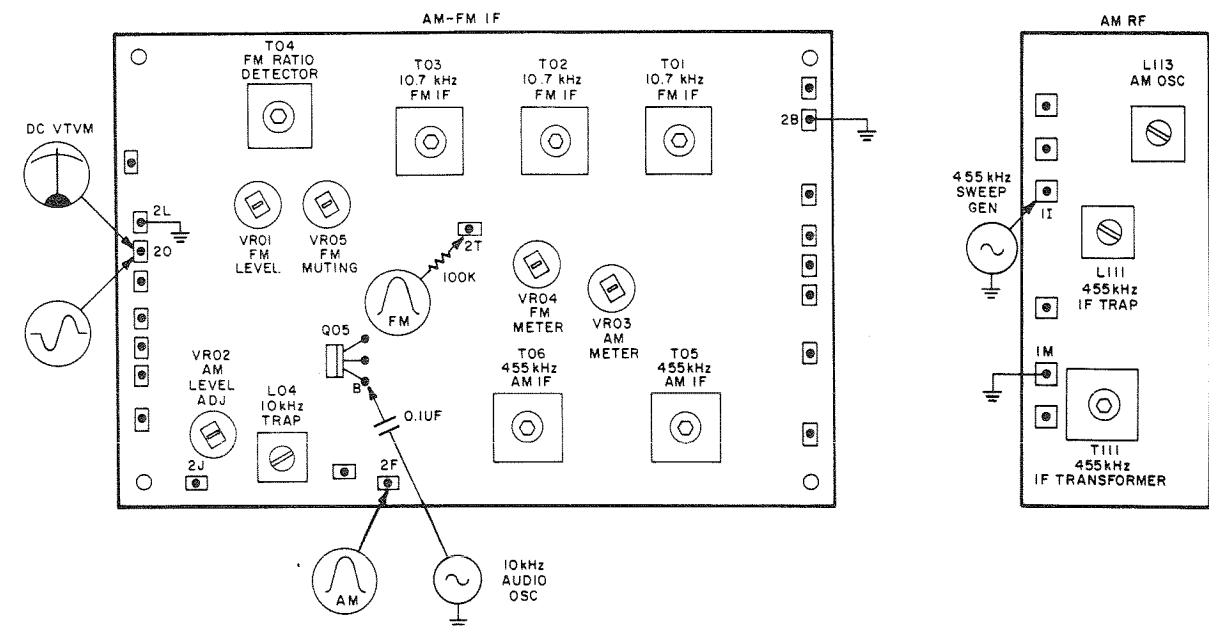
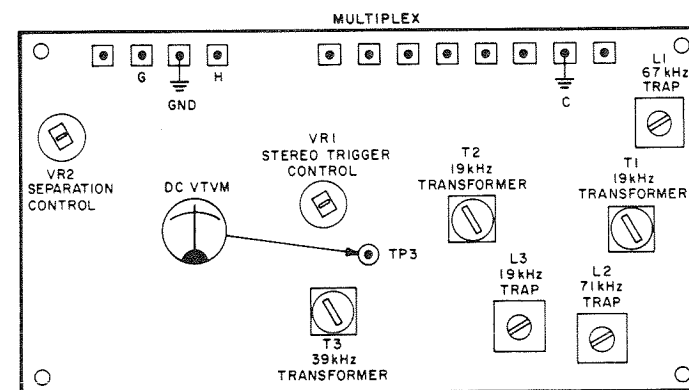
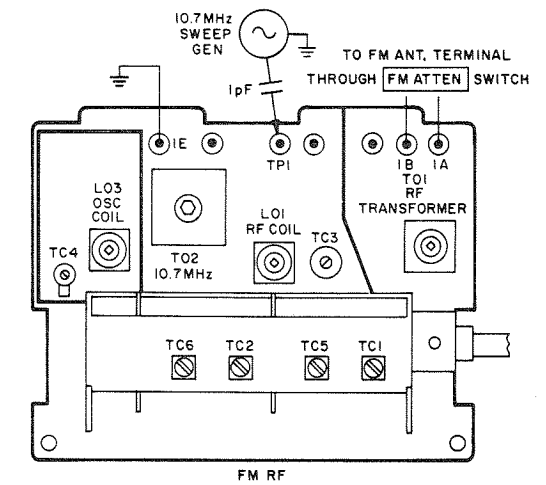

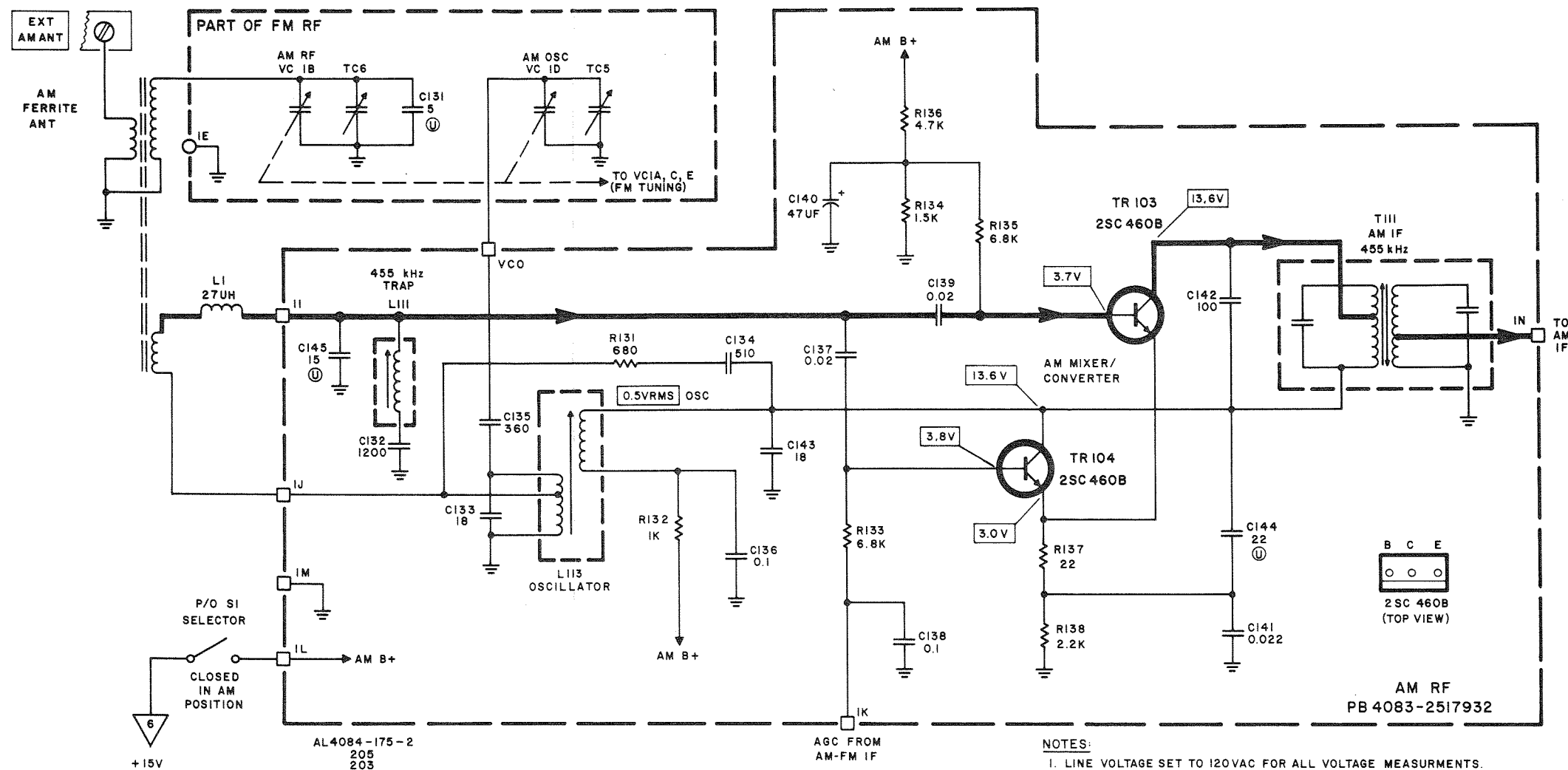

- NOTES:
1. LINE VOLTAGE SET TO 120VAC FOR ALL VOLTAGE MEASUREMENTS.
 2. ALL VOLTAGES ARE $\pm 20\%$
 3. ALL VOLTAGES ARE DC, MEASURED WITH A DC VTVM TO CHASSIS, WITH NO SIGNAL INPUT.
 4. $\text{\textcircled{U}}$ DENOTES PARTS MOUNTED ON UNDERSIDE OF BOARD.

AM RF

Symbol	Description	Part No.	Sug. Ret.
C132	Polystyrene, 1200 pF, 50V	CP4083-0221337	.75
C133	Ceramic, 18pF, 50V, N750	CK4083-0248496	.40
C134	Polystyrene, 510pF, 50V	CP4031-0221328	.70
C135	Polystyrene, 360pF, 50V	CP4083-0221324	.50
C136, 138	Ceramic, 0.1uF, 50V	CK4031-0246007	.40
C137, 139	Ceramic, 0.02uF, 50V	CK4031-0245018	.40
C140	Electrolytic, 47UF, 16V	CE4083-1252525	.65
C141	Mylar, 0.022uF, 50V	CE4083-1275013	.40
C142	Ceramic, 100pF, 50V	CK4031-0248724	.35
C143	Ceramic, 18pF, 50V, N330	CK4083-0248176	.40
C144	Ceramic, 22pF, 50V, NPO	CK4083-0246448	.40
C145	Ceramic, 1pF, 5%, 50V, NPO	CK4083-0246445	.45
L111	Coil, AM IF	LC4031-2140441	.95
L113	Coil, AM Oscillator	LC4031-2134201	.95
R131	680	RF25DC681J	.30
R132	1K	RF25DC102J	.30
R133, 135	6.8K	RF25DC682J	.30
R134	1.5K	RF25DC152J	.30
R136	4.7K	RF25DC472J	.30
R137	22	RF25DC220J	.30
R138	2.2K	RF25DC222J	.30
T111	Transformer, AM IF	ZZ4031-2154101	2.25
TR103, 104	Transistor, 2SC460B	TR4031-0573486	3.20
-	PCB, AM RF	PB4083-2517932	12.25

Unless otherwise specified, all resistors are Deposited Film in ohms, 5%, 1/4 watt. K=Kilohm, M=Megohm

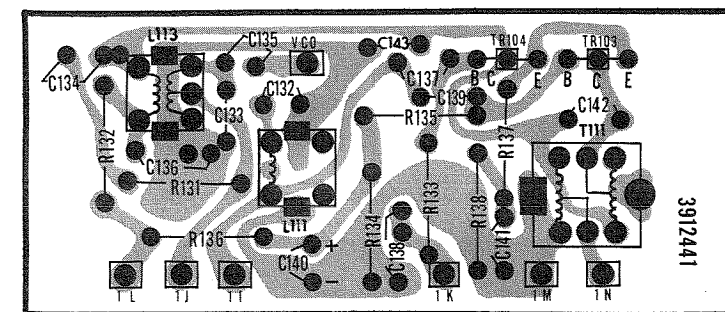

AL4084-111-1

MISCELLANEOUS

Symbol	Description	Part No.	Sug. Ret.
-	Antenna, Ferrite (AM)	LA4083-2134214	4.60
L1	RF Choke, 27uH	LC4031-2227035	.60
VC1	Tuning Gang Assembly (Part of FM RF Board)	CV4083-0281169	9.20

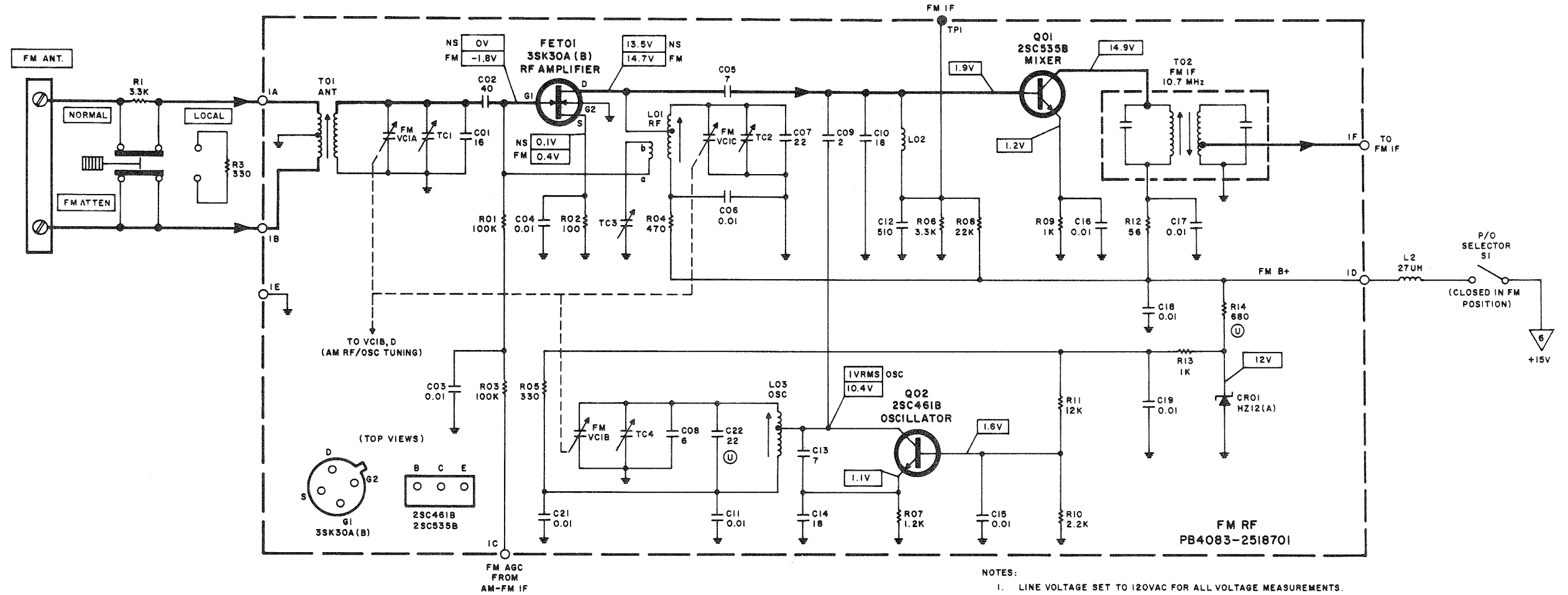

- NOTES:
1. LINE VOLTAGE SET TO 120VAC FOR ALL VOLTAGE MEASUREMENTS.
 2. ALL VOLTAGES ARE $\pm 20\%$.
 3. ALL VOLTAGES ARE DC, MEASURED WITH A DC VTVM TO CHASSIS, AND DENOTED AS FOLLOWS:
 NS XXX NO SIGNAL (ANTENNA TERMINAL SHORTED).
 FM XXX 1mV FM MONO SIGNAL AT 98MHz, ± 75 kHz DEVIATION, 400Hz AT FM ANT.
 4. U DENOTES PARTS MOUNTED ON UNDERSIDE OF BOARD.

AL4084-175-1
205
203

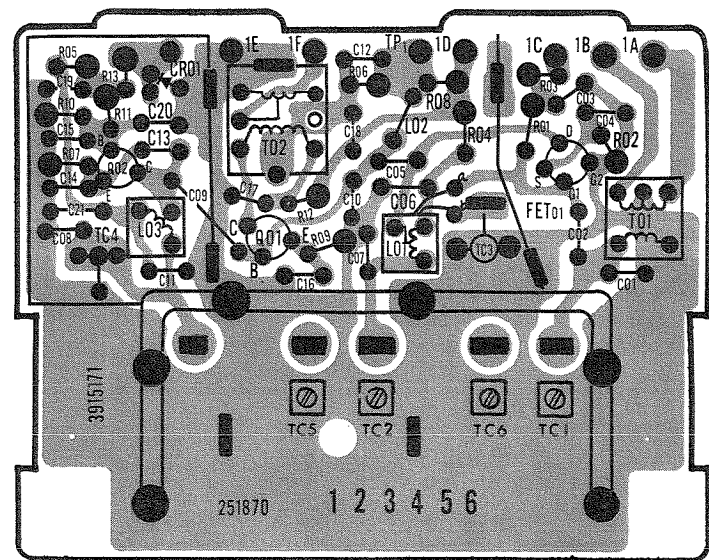

AL4084-111-2

FM RF

Symbol	Description	Part No.	Sug. Ret.
C01	Ceramic, 16pF, 5%, 50V, NPO	CK4083-0246445	.40
C02	Ceramic, 40pF, 5%, 50V	CK4031-0242005	.40
C03, 04, 06, 16, 17, 18, 19	Ceramic, 0.01uF, 25V	CK4083-0245017	.40
C05, 13	Ceramic, 7pF, 50V, NPO	CK4031-0246417	.40
C07	Ceramic, 22pF, 5%, 50V, NPO	CK4083-0246448	.40
C08	Ceramic, 6pF, 5%, 50V, N470	CK4083-0248306	.40
C09	Ceramic, 2pF, 50V	CK4083-0248142	.45
C10	Ceramic, 18pF, 5%, 50V	CK4031-0248666	.40
C11, 15, 21	Ceramic, 0.01uF, 10%, 50V	CK4083-0244141	.40
C12	Polystyrene, 510 pF	CP4031-0221328	.70
C14	Ceramic, 18pF, 5%, 50V, N80	CK4031-0246576	.45
C22	Ceramic, 22pF, 5%, 50V, N220	CK4083-0246448	.40
C31	Ceramic, 5pF, 50V, NPO	CK4083-0246415	.40
CR01	Diode, HZ12(A)	TR4083-2330241	1.60
FET01	FET Transistor, 3SK30A (B)	TR4083-2327132	2.75
L01	Coil, FM RF	LC4083-2134323	1.20
L02	Coil, FM Trap	LC4031-2134041	.40
L03	Coil, FM Oscillator	LC4083-2134324	.40
Q01	Transistor, 2SC535B	TR4031-0573510	4.15
Q02	Transistor, 2SC461B	TR4031-0573507	1.70
R01, 03	100K	RF25DC104J	.30
R02	100	RF25DC101J	.30
R04	470	RF25DC471J	.30

Symbol	Description	Part No.	Sug. Ret.
R05	330	RF25DC331J	.30
R06	3.3K	RF25DC332J	.30
R07	1.2K	RF25DC122J	.30
R08	22K	RF25DC223J	.30
R09, 13	1K	RF25DC102J	.30
R10	2.2K	RF25DC222J	.30
R11	12K	RF25DC123J	.30
R12	56	RF25DC560J	.30
R14	680	RF25DC681J	.30
T01	Coil, FM Antenna	LC4083-2134067	1.95
T02	Transformer, FM IF	ZZ4031-2140233	1.80
VC1A-E	Tuning Gang assembly	CV4083-0281169	9.20
TC3	Trimmer	CT4031-0283114	.80
TC4	Trimmer	CT4031-0283118	1.05
-	PCB, FM RF	PB4083-2518701	26.10

MISCELLANEOUS

Symbol	Description	Part No.	Sug. Ret.
-	Switch, Slide, FM ATTN	SS4031-2627012	.85
L2	RF Choke, 27uH	LC4031-2227035	.60
R1, 2	3.3K	RF25DC332J	.30
R3	330	RF33DC331J	.30

Unless otherwise specified, all resistors are Deposited Film in ohms, 5%, 1/4 watt. K=Kilohm, M=Megohm

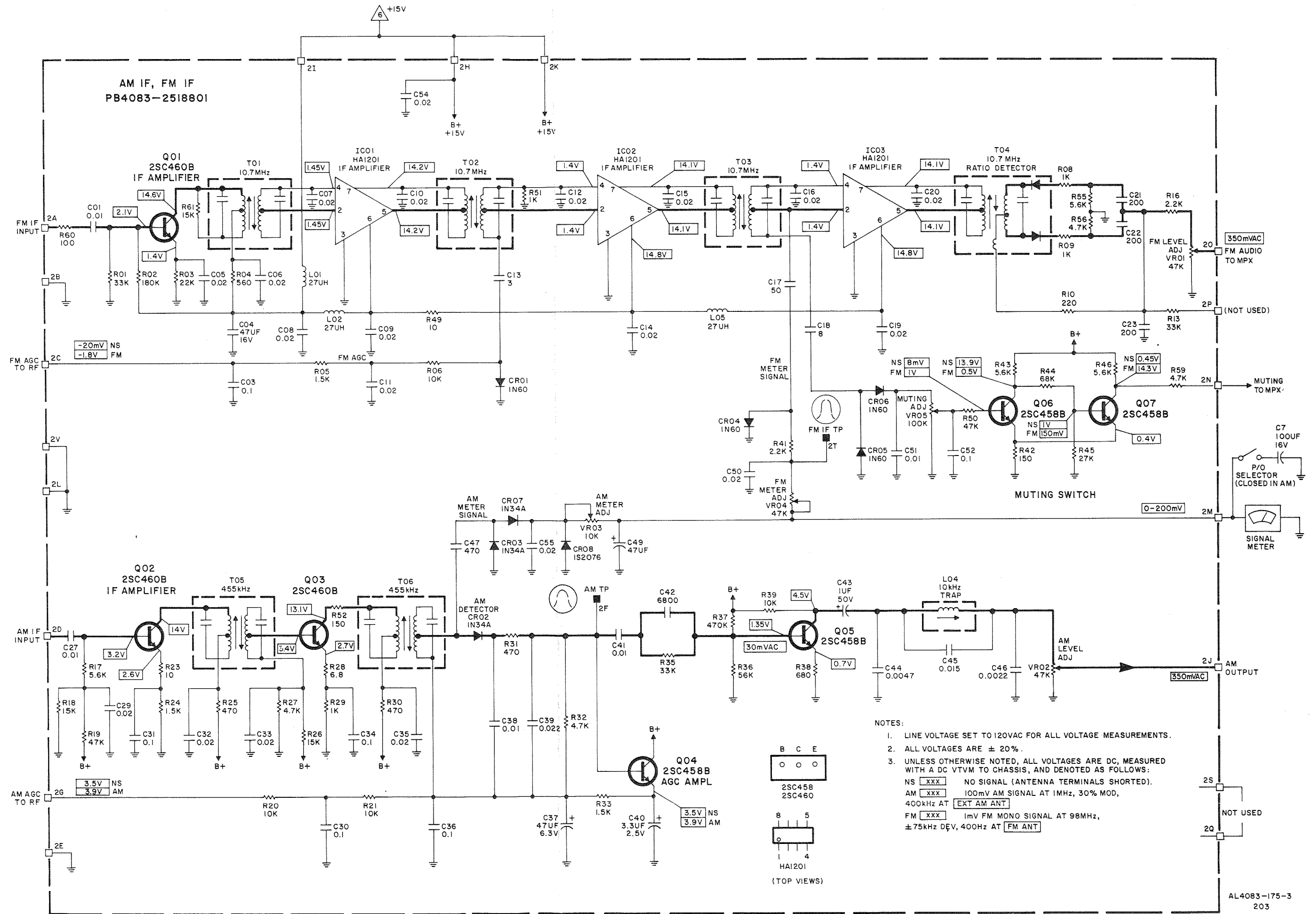

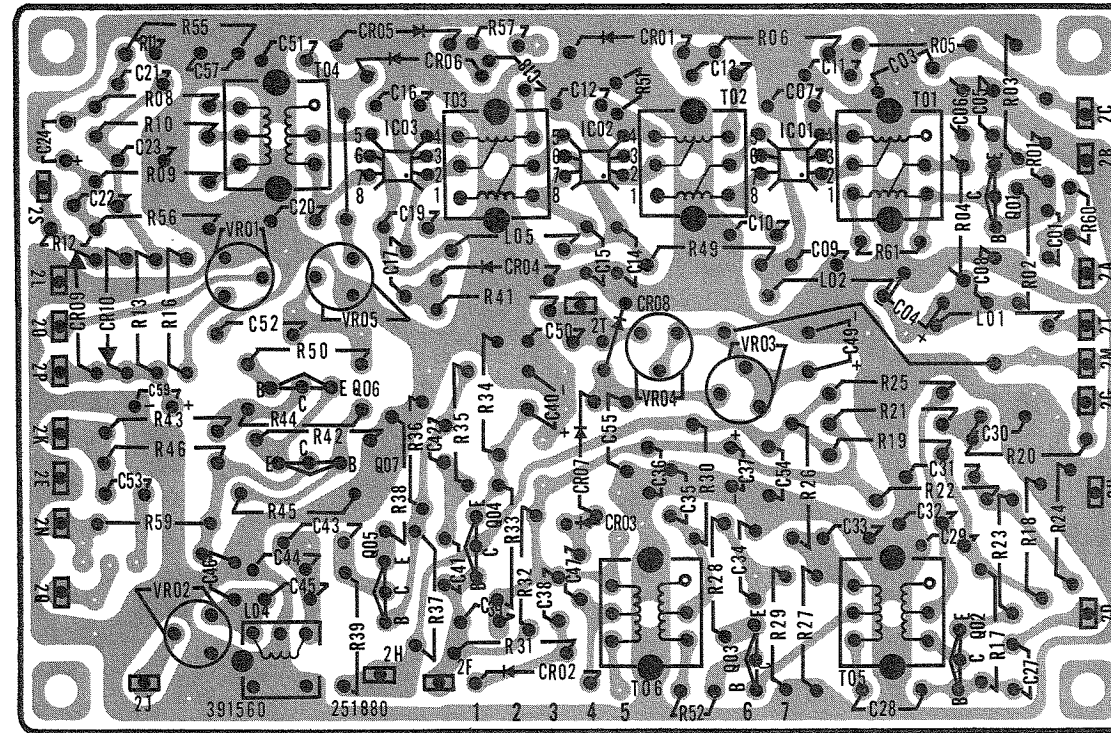

AL4084-III-3

AM-FM IF

Symbol	Description	Part No.	Sug. Ret.
C01, 27	Ceramic, 0.01uF, 25V	CK4031-0245017	.40
C03, 30, 31, 34, 36, 51, 52	Ceramic, 0.1uF, 25V	CK4031-0246007	.40
C04	Electrolytic, 47uF, 16V	CE4083-1252525	.65
C05, 06, 07, 08, 09, 10, 11, 12, 14, 15, 16, 19, 20, 29, 32, 33, 35, 50, 54, 55	Ceramic, 0.02uF	CK4031-0245018	.40
C13	Ceramic, 3pF, 50V	CK4031-0248633	.40
C17	Ceramic, 50pF, 50V	CK4031-0242011	.40
C18	Ceramic, 8pF, 50V	CK4083-0248638	.40
C21, 22, 23	Ceramic, 200pF, 50V	CK4031-0248691	.45
C37, 49	Electrolytic, 47uF, 6.3V	CE4031-0252225	.55
C38, 41	Mylar, 0.01uF, 50V	CY4083-1275011	.40
C39	Mylar, 0.022uF, 50V	CY4083-1275013	.75
C40	Electrolytic, 3.3uF, 25V	CE4083-1252613	.45
C42	Mylar, 0.0068uF, 50V	CY4083-1274016	.40
C43	Electrolytic, 1uF, 50V	CE4083-1252811	.65
C44	Mylar, 0.0047uF, 50V	CY4083-1274015	.40
C45	Mylar, 0.015uF, 50V	CY4083-1275012	.40
C46	Mylar, 0.0022uF, 50V	CY4083-1274013	.40
C47	Polystyrene, 470pF	CP4042-0221327	.60
CR01, 04, 05, 06	Diode, 1N60	TR4031-0575005	.80
CR02, 03, 07	Diode, 1N34A	TR4031-0575002	.80
CR08	Diode, 1S2076	TR4083-2337011	.70
IC01, 02	Integrated Circuit, HA1201	TR4083-2327312	2.10
IC03	Integrated Circuit, HA1201	TR4083-2327311	2.10
L01, 02, 05	Coil, Choke, 27uH	LC4031-2227035	.60
L04	Coil, 10kHz Trap	LB4031-5120145	1.45
Q01, 02, 03	Transistor, 2SC460B	TR4031-0573486	3.20
Q04, 05, 06, 07	Transistor, 2SC458B	TR4031-2320063	1.35
R01, 13, 35	33K	RF25DC333J	.30
R02	180K	RF25DC184J	.30
R03, 16, 41	2.2K	RF25DC222J	.30
R04	560	RF25DC561J	.30

Symbol	Description	Part No.	Sug. Ret.
R05, 24, 33	1.5K	RF25DC152J	.30
R06, 20, 21, 39	10K	RF25DC103J	.30
R08, 09, 29, 51	1K	RF25DC102J	.30
R10	220	RF25DC221J	.30
R17, 43, 46, 55	5.6K	RF25DC562J	.30
R18, 26, 61	15K	RF25DC153J	.30
R19, 50	47K	RF25DC473J	.30
R23, 49	10	RF25DC100J	.30
R25, 30, 31	470	RF25DC471J	.30
R27, 32, 56, 59	4.7K	RF25DC472J	.30
R28	6.8	RF25DC688J	.30
R36	56K	RF25DC563J	.30
R37	470K	RF25DC474J	.30
R38	680	RF25DC681J	.30
R42, 52	150	RF25DC151J	.30
R44	68K	RF25DC683J	.30
R45	27K	RF25DC273J	.30
R60	100	RF25DC101J	.30
T01	Transformer, FM IF	ZZ4031-2140233	2.05
T02, 03	Transformer, FM IF	ZZ4031-2140238	1.85
T04	Detector, FM	ZZ4031-2140242	3.20
T05	Transformer, AM IF	ZZ4031-2154102	2.25
T06	Transformer, AM IF	ZZ4031-2154103	2.25
VR01, 02, 04	Variable, 47K (B)	RV4083-0151253	.65
VR03	Variable, 10K (B)	RV4083-0151252	.70
VR05	Variable, 100K (B)	RV4083-0151254	.65
-	PCB, AM-FM IF	PB4083-2518801	60.10

MISCELLANEOUS

Symbol	Description	Part No.	Sug. Ret.
-	Meter, Signal	MC4084-2577122	7.20
C7	Electrolytic, 100uF, 16V	CE4031-0252531	.70

Unless otherwise specified, all resistors are Deposited Film in ohms, 5%, 1/4 watt. K=Kilohm, M=Megohm

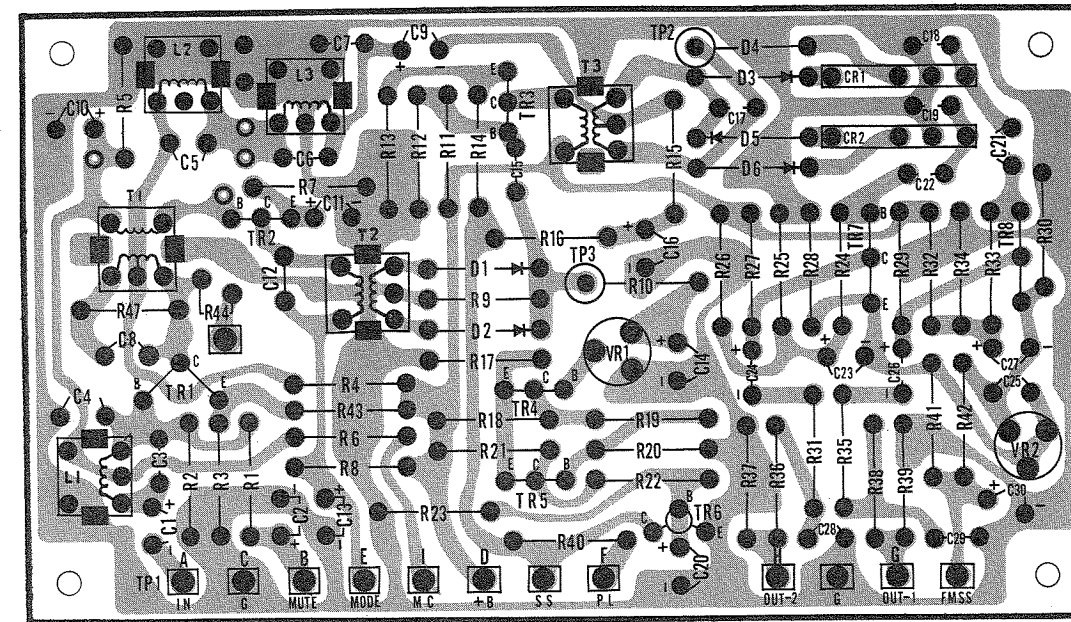

MULTIPLEX

Symbol	Description	Part No.	Sug. Ret.
C1, 2, 9, 10, 11, 13, 16	Electrolytic, 3.3uF, 25V	CE4083-1252613	.65
C3, 5	Polystyrene, 300pF, 50V	CP4083-0221322	.50
C6	Mylar, 0.01uF, 50V	CY4083-1275011	.40
C7	Ceramic, 220pF, 50V	CK4031-0248732	.40
C8	Polystyrene, 5600pF, 50V	CP4083-0221517	.95
C12	Polystyrene, 0.01uF, 50V	CP4083-0221385	.55
C14, 24, 26	Mylar, 0.22uF, 50V	CY4083-1276113	.75
C15	Polystyrene, 3000pF, 50V	CP4083-0221346	.50
C17	Polystyrene, 2700pF, 50V	CP4083-0221345	.50
C20	Electrolytic, 1uF, 50V	CE4083-1252811	.65
C21, 22	Mylar, 0.1uF, 50V	CY4083-1276011	.40
C23, 27	Electrolytic, 47uF, 16V	CE4083-1252525	.65
C25, 31, 32	Mylar, 0.0033uF, 50V	CY4083-1274014	.40
C28, 29	Mylar, 0.0047uF, 50V	CY4083-1274015	.40
C33	Electrolytic, 100uF, 16V	CE4031-0252531	.70
CR1, 2	Encapsulated Circuit	EP4031-0186007	1.75
D1, 2	Diode, 1N34A	TR4031-0575002	.80
D3, 4, 5, 6	Diode, 1S2076	TR4083-2337011	.70
L1, 2	Coil, 71 kHz Trap	LB4031-5120145	1.45
L3	Coil, 19 kHz Trap	LB4031-0324005	1.35
R1	82K	RF25DC823J	.30
R2, 24, 26, 32, 33	33K	RF25DC333J	.30
R3, 36, 38, 44	1K	RF25DC102J	.30
R4, 28, 30	1.8K	RF25DC182J	.30
R5, 27, 29, 37, 39	15K	RF25DC153J	.30
R6, 12	100K	RF25DC104J	.30
R7, 17	1.2K	RF25DC122J	.30
R8	3.3K	RF25DC332J	.30
R9, 13, 14, 18, 21, 43	10K	RF25DC103J	.30
R10	27K	RE25DC273J	.30

Symbol	Description	Part No.	Sug. Ret.
R11	390K	RF25DC394J	.30
R15, 19, 22	12K	RF25DC123J	.30
R16	180K	RF25DC184J	.30
R20, 25, 34, 46	4.7K	RF25DC472J	.30
R23	6.8K	RF25DC682J	.30
R31, 35	1.5K	RF25DC152J	.30
R40	180	RF25DC181J	.30
R45	22K	RF25DC223J	.30
R47	120K	RF25DC124J	.30
R48	68	RF25DC680J	.30
T1	Transformer, 19 kHz MPX	ZZ4083-2134371	1.45
T2	Transformer, 19 kHz MPX	ZZ4083-2134372	1.45
T3	Transformer, 38 kHz MPX	ZZ4083-2134341	1.45
TR1, 7, 8	Transistor, 2SC458LG(C)	TR4031-2320073	1.65
TR2, 3, 4, 5	Transistor, 2SC458(C)	TR4031-2320063	1.35
TR6	Transistor, 2SC1213B	TR4083-2327332	1.55
VR1	Variable, 100K (B)	RV4031-0151244	.90
VR2	Variable, 22K (B)	RV4083-0151251	.90
-	PCB, Multiplex	PB4083-2517944	46.05

MISCELLANEOUS

Symbol	Description	Part No.	Sug. Ret.
-	Lamp STEREOBEACON (25mA, 5V)	LM4083-2767091	1.65
-	Switch, Lever, MODE, HIGH FILTER, LOUDNESS	SU4083-2637171	1.65
C5	Electrolytic, 220uF, 16V	CE4042-0252532	.90
C6	Mylar, 4700pF, 50V	CY4083-1274015	.40
R6, 7	680	RF25DC681J	.30
R10	2.2K	RF25DC223J	.30

Unless otherwise specified, all resistors are Deposited Film in ohms, 5%, 1/4 watt. K=Kilohm, M=Megohm

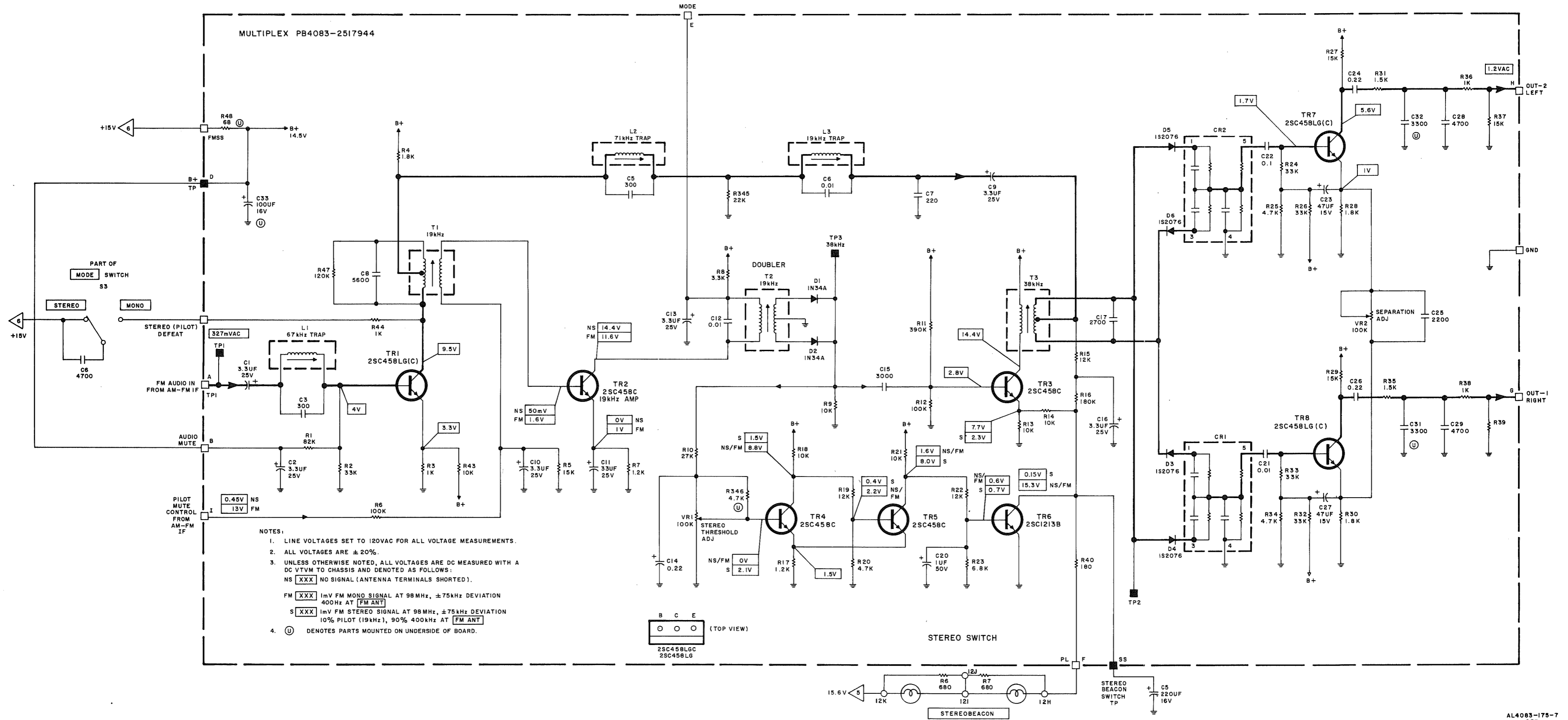

- NOTES:
1. LINE VOLTAGES SET TO 120VAC FOR ALL VOLTAGE MEASUREMENTS.
 2. ALL VOLTAGES ARE $\pm 20\%$.
 3. UNLESS OTHERWISE NOTED, ALL VOLTAGES ARE DC MEASURED WITH A DC VTVM TO CHASSIS AND DENOTED AS FOLLOWS:
 NS [XXX] NO SIGNAL (ANTENNA TERMINALS SHORTED).
 FM [XXX] 1mV FM MONO SIGNAL AT 98 MHz, ± 75 kHz DEVIATION 400Hz AT [FM ANT]
 S [XXX] 1mV FM STEREO SIGNAL AT 98 MHz, ± 75 kHz DEVIATION 10% PILOT (19kHz), 90% 400kHz AT [FM ANT]
 4. $\text{\textcircled{U}}$ DENOTES PARTS MOUNTED ON UNDERSIDE OF BOARD.

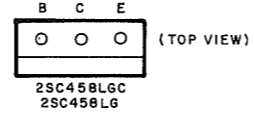

PREAMPLIFIER

Symbol	Description	Part No.	Sug. Ret.
C401, 402, 415, 416	Electrolytic, 10uF, 25V	CE4083-1252621	.55
C405, 406, 407, 408	Ceramic, 100pF, 50V	CK4083-1248724	.35
C409, 410	Mylar, 2200pF, 50V	CY4083-1274013	.40
C411, 412	Mylar, 6800pF, 50V	CY4083-1274016	.40
C413, 414	Electrolytic, 100uF, 10V	CE4083-1252331	.65
C417	Electrolytic, 47uF, 50V	CE4083-1252825	.85
Q401, 402	Integrated Circuit, FA6001D	TR4083-2327301	3.20
R401, 402	470	RF25DC471J	.30
R405, 406	100K	RF25DC104J	.30
R407, 408	1K	RF25DC102J	.30
R409, 410	33K	RF25DC333J	.30
R411, 412, 413, 414	470K	RF25DC474J	.30
R415	Composition, 3.3K, 10%, 1/4W	RC07BF332K	.30
-	PCB, Preamplifier	PB4083-2518712	12.50

MISCELLANEOUS

Symbol	Description	Part No.	Sug. Ret.
-	Jack Strip, PHONO, AUX	ET4083-2677131	2.40
-	Jack Strip, TAPE IN, RCDR OUT	ET4083-2677141	1.45
-	Jack, PHONES, RCDR OUT	JK4083-2677061	1.60
-	PCB, Lamp	PB4083-2518571	3.55
-	Lamp, PHONO, AM, FM, AUX (65mA, 6.3V)	LM4084-2767115	1.35
-	Lamp, Dial Pointer (60mA, 5V)	LM4084-2767094	1.65
-	Lamp Dial, Meter, Fuse Type (250mA, 6.3V)	LM4083-2767201	1.15
-	Meter, Signal	MC4083-2577122	7.20
-	Switch, Rotary, SELECTOR	SR4084-2617004	7.65
-	Switch, Lever, TAPE MONITOR	SU4083-2637171	1.65
C7	Electrolytic, 100uF, 16V	CE4031-0252531	.70
R8	18	RF25DC180J	.30

Unless otherwise specified, all resistors are Deposited Film in ohms, 5%, 1/4 watt. K = Kilohms, M = Megohms

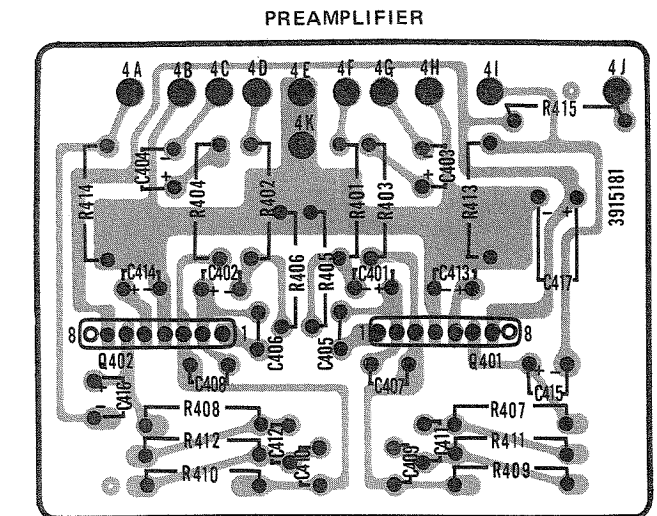

AL4084-III-5

LAMP BOARD

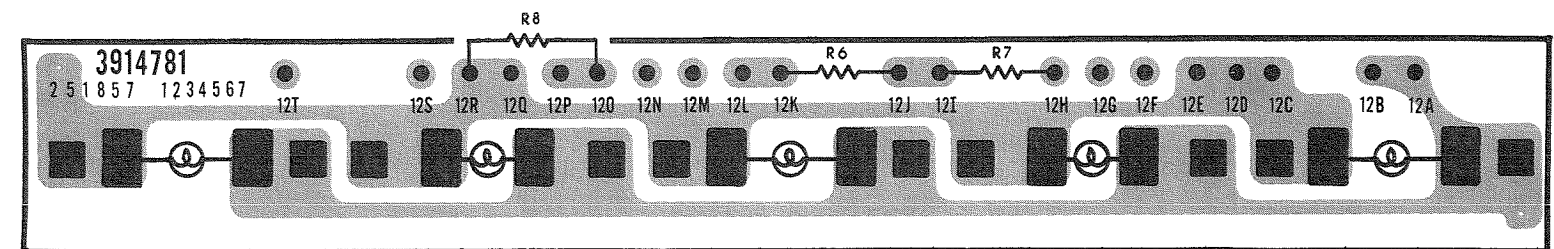

COPPER SIDE SHOWN

AL4083-III-6

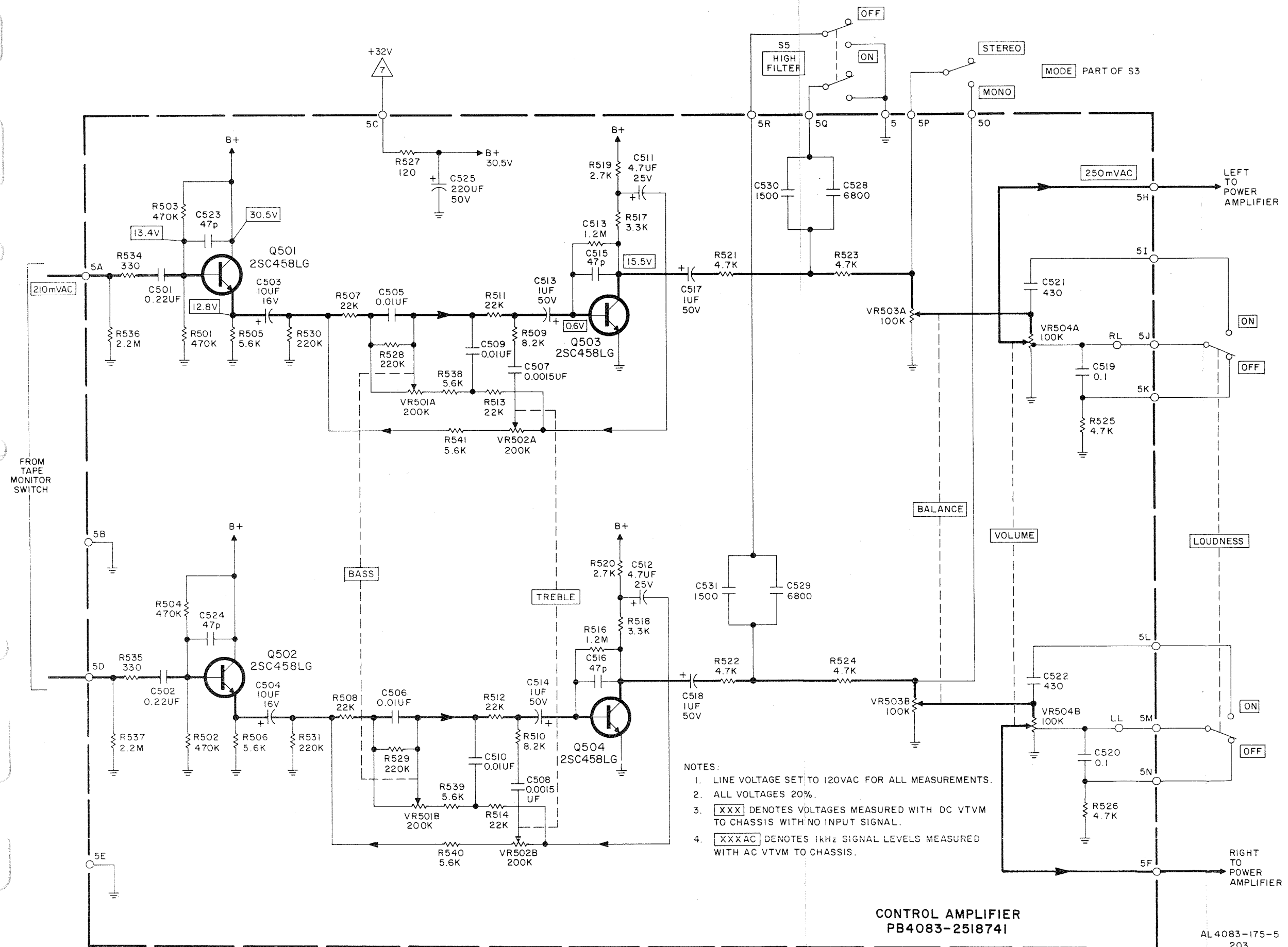

- NOTES:
1. LINE VOLTAGE SET TO 120VAC FOR ALL MEASUREMENTS.
 2. ALL VOLTAGES 20%.
 3. [XXX] DENOTES VOLTAGES MEASURED WITH DC VTVM TO CHASSIS WITH NO INPUT SIGNAL.
 4. [XXXAC] DENOTES 1kHz SIGNAL LEVELS MEASURED WITH AC VTVM TO CHASSIS.

CONTROL AMPLIFIER
PB4083-2518741

POWER AMPLIFIER - POWER SUPPLY

Symbol	Description	Part No.	Sug. Ret.
C01, 02	Electrolytic, 3.3uF, 50V	CE4083-1252813	.65
C03, 04, 21, 23	Electrolytic, 47uF, 50V	CE4083-1252825	.85
C05, 06, 07, 08	Electrolytic, 100uF, 50V	CE4083-1252831	.95
C09, 10	Ceramic, 47pF, 50V	CK4031-0248716	.40
C11, 12	Mylar, 0.1uF, 50V	CY4083-1276011	.75
C13, 14	Ceramic, 470pF, 50V	CK4083-0243509	.45
C15, 16	Ceramic, 150pF	CK4083-0248728	.45
C22	Electrolytic, 220uF, 16V	CE4083-1252532	.90
C24	Electrolytic, 100uF, 25V	CE4083-1252631	.75
C25, 26	Ceramic, 0.01uF, 50V	CK4031-0245408	.50
CR01, 02, 03, 04, 05, 06	Varistor, HV-26G	TR4083-2337071	.65
CR11	Diode, Zener, AW01-33	TR4031-2327076	2.40
CR12	Diode, Zener, AW01-16	TR4031-2327077	2.75
CR13, 14	Diode, Ge, V03C	TR4031-2327031	.95
Q01, 02	Transistor, 2SA673A	TR4083-2327283	1.35
Q03, 04, 05, 06	Transistor, 2SC708C	TR4083-0573557	2.95
Q07, 08	Transistor, 2SA537C	TR4083-0573560	5.60
Q11	Transistor, 2SC1213A	TR4083-2327293	1.55
Q12	Transistor, 2SC1061C	TR4031-2327153	2.80
R01, 02	1K	RF25DC102J	.30
R03, 04	120K	RF25DC124J	.30
R05, 06	47K	RF25DC473J	.30
R07, 08	820	RF25DC821J	.30
R09, 10	47	RF25DC470J	.30
R11, 12	3.3K	RF25DC332J	.30
R13, 14	1.8K	RF25DC182J	.30
R15, 16	2.7K	RF25DC272J	.30
R17, 18	Composition, 10, 10%, 1/2W	RC20BF100K	.30
R19, 20, 23, 24	220	RF25DC221J	.30
R21, 22, 52	Composition, 22, 10%, 1/2W	RC20BF220K	.30
R25, 26	Metal Oxide Film, 10, 5%, 2W	RP4083-0119151	.95
R27, 28, 29, 30	Metal Oxide Film, 0.47, 5%, 3W	RP4083-0119127	.95
R31, 32	4.7K	RF25DC472J	.30
R37, 38	51	RF25DC510J	.30
R43, 44	33	RF25DC330J	.30
R51	Composition, 68, 10%, 1/2W	RC20BF680K	.35
R53	Composition, 560, 10%, 1/2W	RC20BF561K	.35
R54	Composition, 390, 10%, 1/2W	RC20BF391K	.35
R55	Composition, 1.8K, 10%, 1/2W	RC20BF182K	.35
R56	Metal Oxide Film, 220, 10%, 5W	RP4083-0111851	.95
R57	Composition, 6.8K, 10%, 1/2W	RC20BF682K	.35
R58	Composition, 220, 10%, 1/2W	RC20BF221K	.35
TH01, 02	Thermister, 15D26	RT4083-0576042	.55
VR01, 02	Resistor, Variable, 100 (B)	RV4083-0151226	1.05
VR03, 04	Resistor, Variable, 200 (B)	RV4083-0151223	.65
-	Circuit Board Assembly, Power Amplifier	PB4083-2518732	67.20

MISCELLANEOUS

Symbol	Description	Part No.	Sug. Ret.
-	AC Outlet	JK4083-2657051	.75
-	Jack, PHONES	JK4083-2677061	1.60
-	* Jack/Plug, Voltage Selector	JK4083-2657121	4.00
-	Power Cord	W4084-2740241	2.10
-	Switch, Rotary, POWER/SPKRS	SR4083-2617133	5.55
-	Terminal Strip, Speakers	ET4083-2687321	3.10
-	Transformer, Power, 120V	TD4083-2217441	33.00
-	* Transformer, Power, Multi-voltage	TE4083-2217442	39.00
C1, 2	Electrolytic, 2000uF, 50V	CE4083-0259757	4.25
C3	Electrolytic, 2200uF, 90V	CE4083-0259799	7.55
C4	Ceramic, 4700pF, 150VAC	CK4042-0243873	.95
F1	Line Fuse, 2A, 125V, Slo-Blo	FL51313-2	.75
* F1	Line Fuse, 1A, 250V, Slo-Blo	FL51313-3	.80
F2, 3	Output Fuse, 2A, 125V	FL51313-28	.75
F4	Lamp Fuse, 3A, 125V, Pigtail	FL4084-2727085	.75
R4, 5	Composition, 470, 10%, 1/2W	RC20BF471K	.35
R9	Composition, 2.7M, 10%, 1/2W	RC20BF275K	.35

* Denotes components used in export units only

Unless otherwise specified, all resistors are Deposited Film in ohms, 5%, 1/2 watt. K = Kilohm, M = Megohm

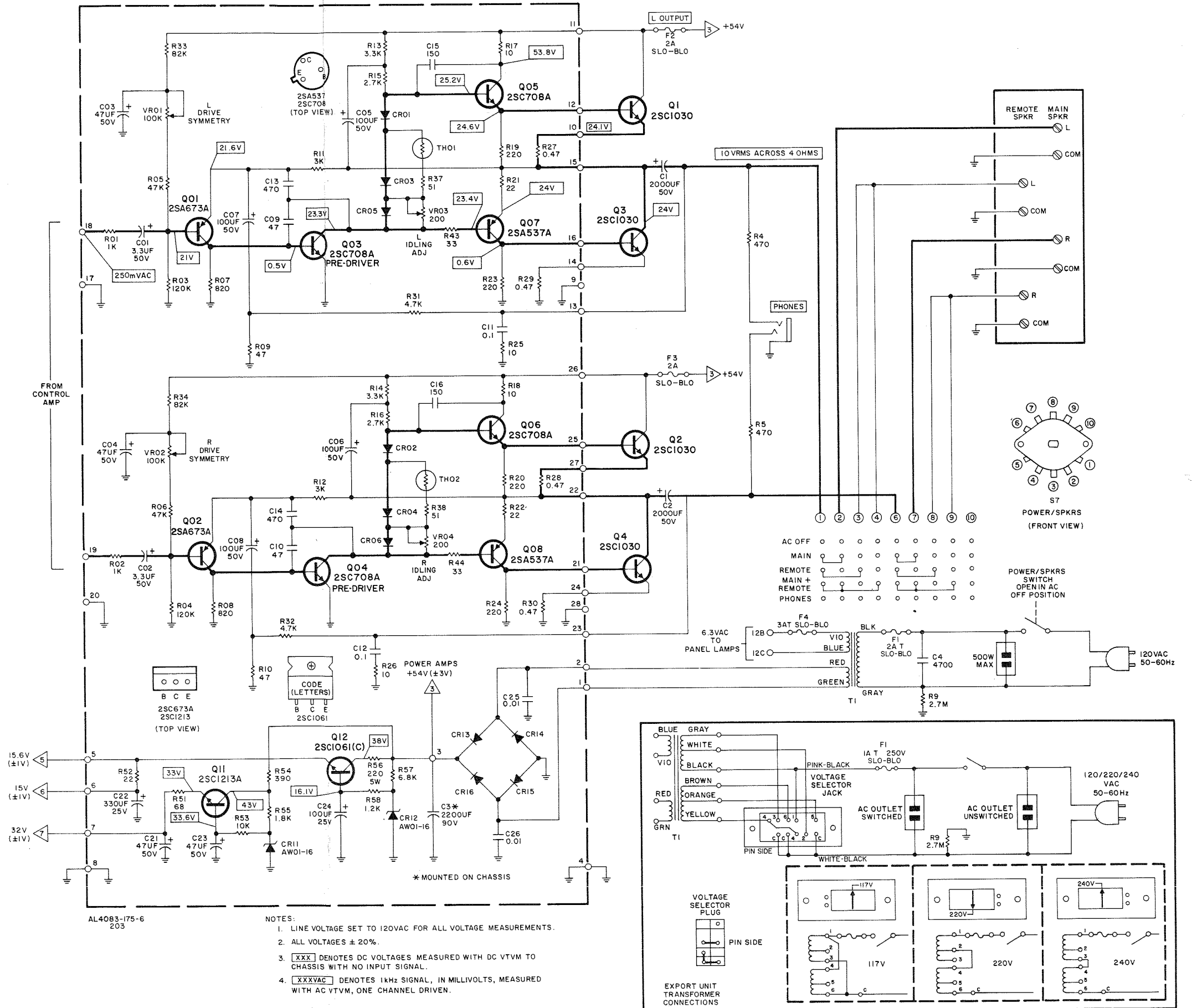

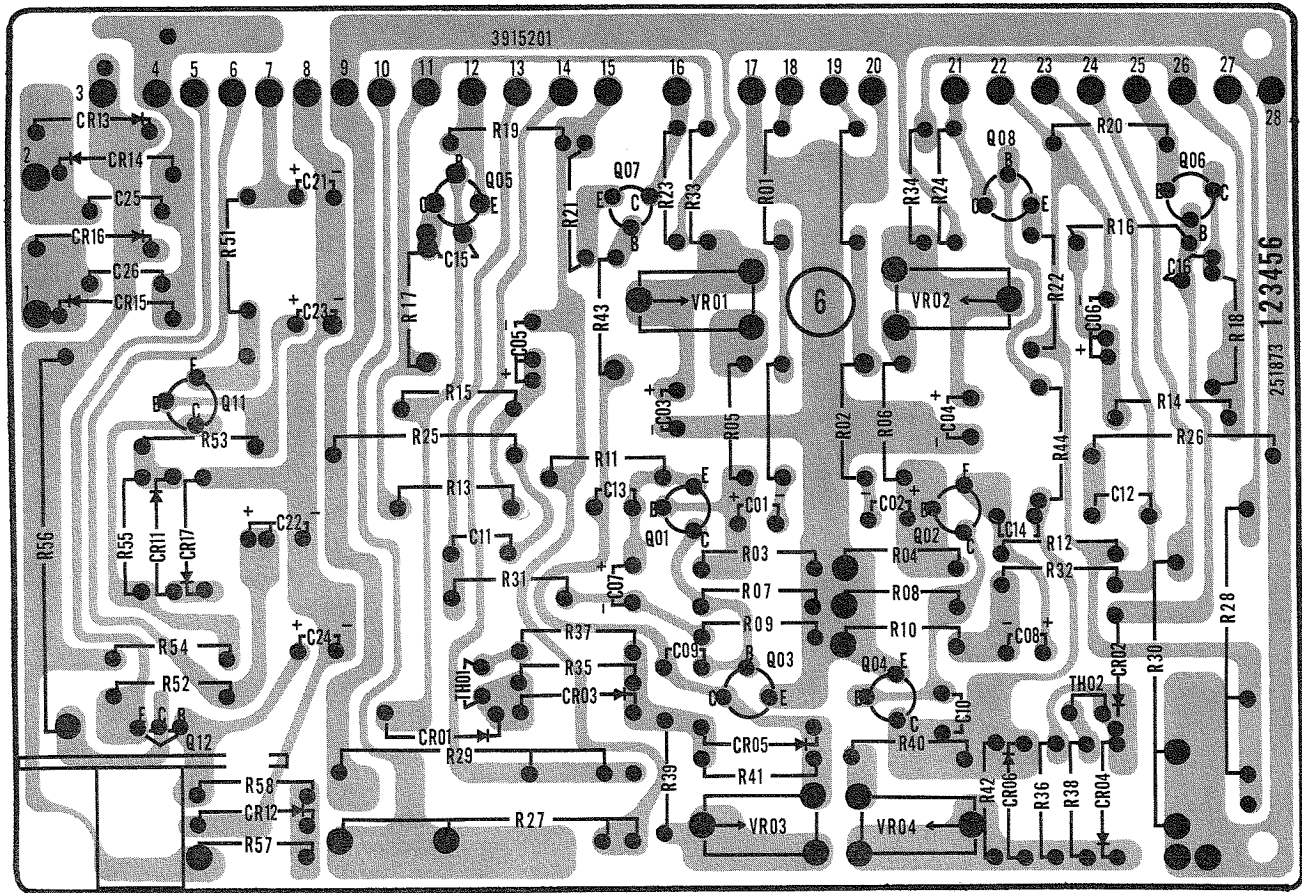

AL4084-III-8

DRIVE SYMMETRY ADJUSTMENT

CAUTION:

- (A) Make measurements with both channels driven.
- (B) Use a load resistor with a minimum rating of 50 watts.

- (1) Connect 4-ohm load resistors between L MAIN SPKR and COM and R MAIN SPKR and COM terminals. Connect oscilloscope across 4-ohm load resistor between L MAIN SPKR and COM. Set SELECTOR switch to AUX 1.
- (2) Connect a low-distortion sine wave signal generator between L AUX 1 IN jack and chassis ground. Set the signal generator frequency to 1000 Hz at a level of 250 mV.
- (3) Observe the sine wave displayed on the oscilloscope. Turn the VOLUME control to increase the output until the sinewave clips. Adjust VR01 until the level of clipping is identical for each half-cycle.
- (4) Connect an oscilloscope across the 4-ohm load resistor between R MAIN SPKR and COM.
- (5) Connect a low-distortion sine wave generator between R AUX 1 IN jack and chassis ground. Set the signal generator frequency to 1000 Hz at a level of 250 mV.
- (6) Observe the sine wave displayed on the oscilloscope. Turn the volume control to increase the output until the sine wave clips. Adjust VR02 until the level of clipping is identical for each half-cycle.

IDLE CURRENT ADJUSTMENT

NOTE: This adjustment is very sensitive to changes in ambient temperature. Allow set to operate for 10 minutes before attempting this adjustment.

- (1) Turn VOLUME control to minimum.
- (2) Connect DC VTVM between terminals 9 and 14 on the Power Amplifier board.
- (3) Adjust VR03 for an indication of 15-35 mV on the DC VTVM.
- (4) Connect DC VTVM between terminals 24 and 28.
- (5) Adjust VR04 for an indication of 15-35 mV on the DC VTVM.

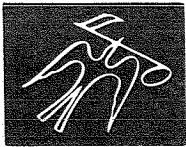
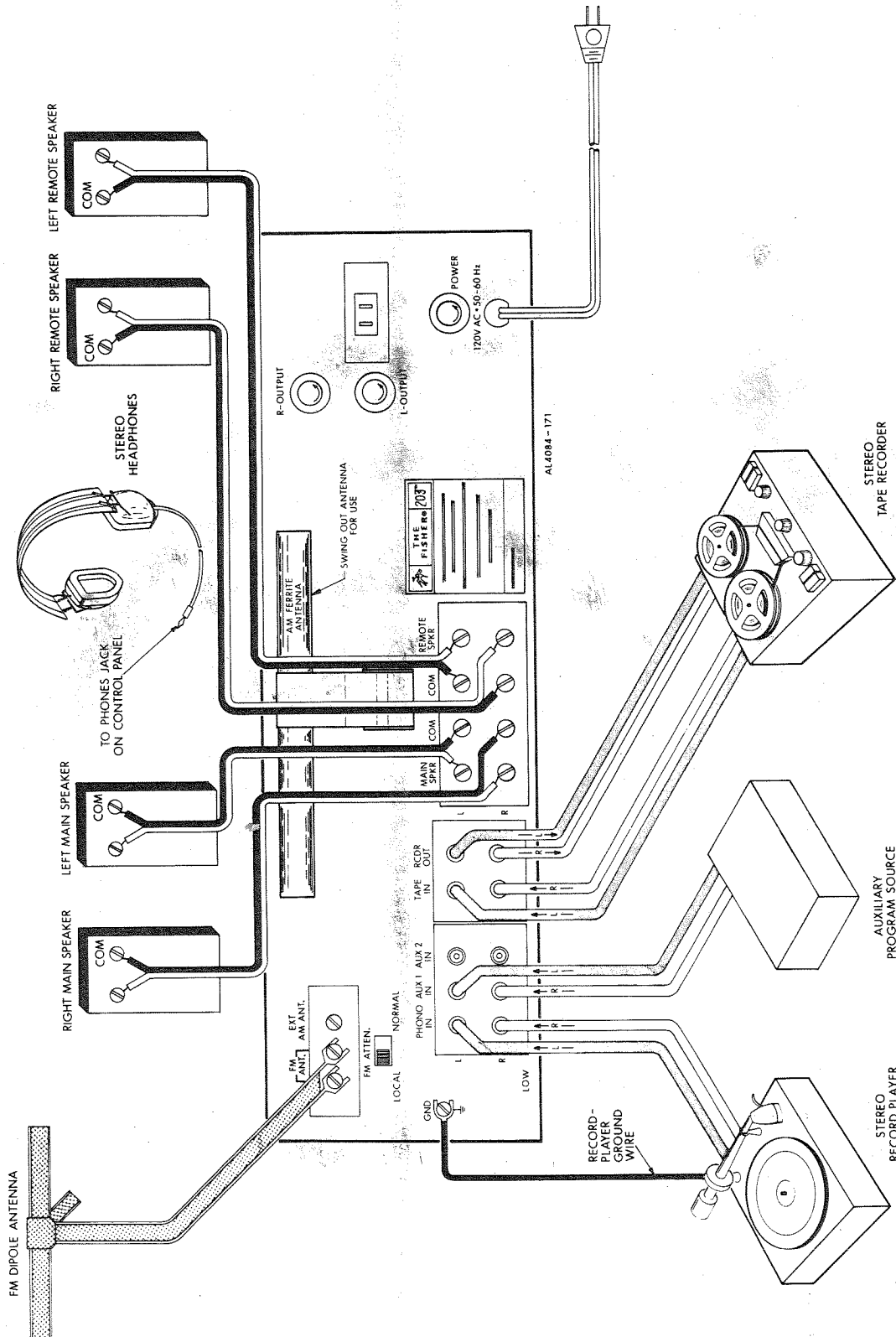

BECAUSE ITS PRODUCTS ARE SUBJECT TO CONTINUOUS IMPROVEMENT, FISHER RADIO RESERVES THE RIGHT TO MODIFY ANY DESIGN OR SPECIFICATION WITHOUT NOTICE AND WITHOUT INCURRING ANY OBLIGATION.

FISHER RADIO • LONG ISLAND CITY • NEW YORK 11101