

# SERVICE MANUAL

PRICE \$1.00

## 20-R

SERIAL NUMBERS  
FROM 10001



# The Fisher<sup>®</sup> 20-R<sup>™</sup>

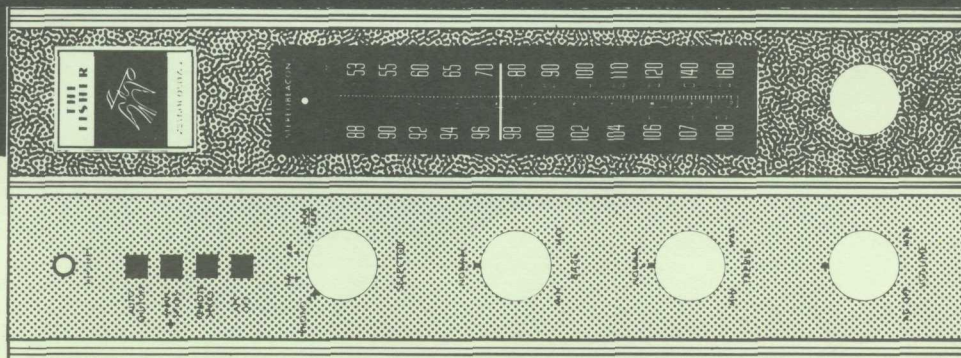

**WORLD LEADER IN HIGH QUALITY STEREO**



## REQUIRED TEST EQUIPMENT

The following equipment is required to completely test and align modern high-fidelity amplifiers, tuners, and receivers.

Line Voltage Autotransformer or Voltage Regulator  
DC Vacuum Tube Volt ohmmeter  
Accurately Calibrated AC Vacuum Tube Voltmeter  
Oscilloscope ((Flat to 100 kHz Minimum)  
Low-Distortion Audio (Sine Wave) Generator  
Intermodulation Distortion Analyzer  
Harmonic Distortion Analyzer  
2 – Load resistors, 8-Ohms, 100 Watt (Minimum Rating)  
AM/FM Signal Generator

10.7 MHz Sweep Generator  
Multiplex Generator  
(preferably with RF output)  
455 kHz Sweep Generator  
Ferrite Test Loop Stick  
2 – Full Range Speakers for Listening Tests  
Stereo Source – Turntable, Tape Recorder, etc.  
Soldering Iron with Small Tip, Fully Insulated from AC Line  
Suction Desoldering Tool

**CAUTION:** This precision high-fidelity instrument should be serviced only by qualified personnel, trained in the repair of transistor equipment and printed circuitry.

Many of these items are included only as a reminder – they are normal procedures for experienced technicians. Shortcuts may be taken, but these often cause additional damage to transistors, circuit components, or printed circuit boards.

**SOLDERING:** A well-tinned, hot, clean soldering iron tip will make soldering easier, without causing damage to the printed circuit board or the components mounted on it. Regular use of a sponge cleaner will maintain a clean soldering surface. The heat available at the tip, (not the wattage of the iron) is important. Some 50-watt irons reach temperatures of 1,000° F, while others will hardly melt solder. Small-diameter tips should be used for single solder connections, pyramid and chisel tips for large areas.

Always disconnect the AC power cord from the line when soldering. Turning the power switch OFF is not sufficient. Power-line leakage paths, through the heating element of the iron, may destroy transistors.

**PARTS REMOVAL:** If a part is not being returned for in-warranty factory replacement, it may be cut in half (with diagonal cutting pliers) to make removal easier. Multiple terminal parts, such as IF transformers, or electrolytic capacitors, should be removed using special de-soldering tips made especially for this purpose. Removing solder from terminals, reduces the possibility of breaking the printed circuit board when the part is removed.

**ACCIDENTAL SHORTS:** A clean working area, free of metal particles, screws, etc., is an important preventive in avoiding servicing problems. Screws, removed from the chassis during servicing, should be stored in a box until needed. While a set is operating, it takes only an instant for a base-to-collector short to destroy a transistor (and others direct-coupled to it). In the time it takes for a dropped machine screw, washer, or screwdriver, to contact a pair of socket terminals (or terminal and chassis), a transistor can be ruined.

**SOLID-STATE DEVICES:** Integrated Circuits contain the equivalent of many circuit parts, including transistors, diodes, resistors, and capacitors. The preferred troubleshooting procedure requires isolating the trouble to one stage using AC signal tracing methods. Once the suspected stage is located, the DC voltages at the input and output leads are measured to give an accurate indication of the operating conditions of the IC. DO NOT use an ohmmeter to check continuity with the IC mounted on the printed circuit board. Forward biasing the internal junctions within the IC may burn out the transistors. Do not replace a defective IC until all external resistors, capacitors, and transformers are checked first, to prevent the replacement IC from failing immediately due to a defect in the connecting components. Solder and unsolder each lead separately using a pliers or other heat sink on the lead to prevent damage from excessive heat. Check that the leads are

connected to the correct locations on the printed circuit board before turning the set on.

Whenever possible, a transistor tester should be used to determine the condition of a transistor or diode. Ohmmeter checks do not provide conclusive data, and may even destroy the junction(s) within the device.

Never attempt to repair a transistor power amplifier module until the power supply filter-capacitors are fully discharged.

If an output or driver transistor becomes defective (opens or shorts), always check ALL direct-coupled transistors and diodes in that channel. In addition, check the bias pot., and other parts in the bias network, before installing replacement transistors. All output and driver transistors in one channel may be destroyed if the bias network is defective. After parts replacement, always check the bias adjustment for specified idling current.

In some applications, replacement of transistors must be made from the same beta group as the original type. The beta group is indicated by a colored marking on the transistor. Be sure to include this information when ordering replacement transistors.

When mounting a replacement power transistor, be sure the bottom of the flange, mica insulator, and the surface of the heat sink, are free of foreign matter. Dust and grit will prevent flat contact, reducing heat transfer to the heat sink. Metallic particles can puncture the insulator, cause a short, and destroy the transistor.

Silicone grease must be used between the transistor and the mica insulator, and between the mica and the heat sink, for best heat transfer. Use Dow-Corning DC-3, or an equivalent compound made for power transistor heat conduction.

Use care when making connections to speakers and output terminals. To reduce the possibility of shorts, lugs should be used on the exposed ends, or stranded wire should be tinned to prevent frayed wire ends. Current in the speakers and output circuitry is quite high – poor contacts, or small sized wire, can cause significant power losses in the system. For wire lengths greater than 30 feet, 16 AWG, or heavier, should be used.

**VOLTAGE MEASUREMENTS:** All voltages are measured with the line voltage adjusted to 120 volts. All measured voltages are  $\pm 10\%$ . DC voltages are measured to ground with a VTVM, with no signal input unless otherwise noted. AC signal voltages are measured under the conditions specified on the schematic.

**ALIGNMENT PROCEDURES:** DO NOT attempt realignment unless the required test equipment is available, and the alignment procedure is thoroughly understood.



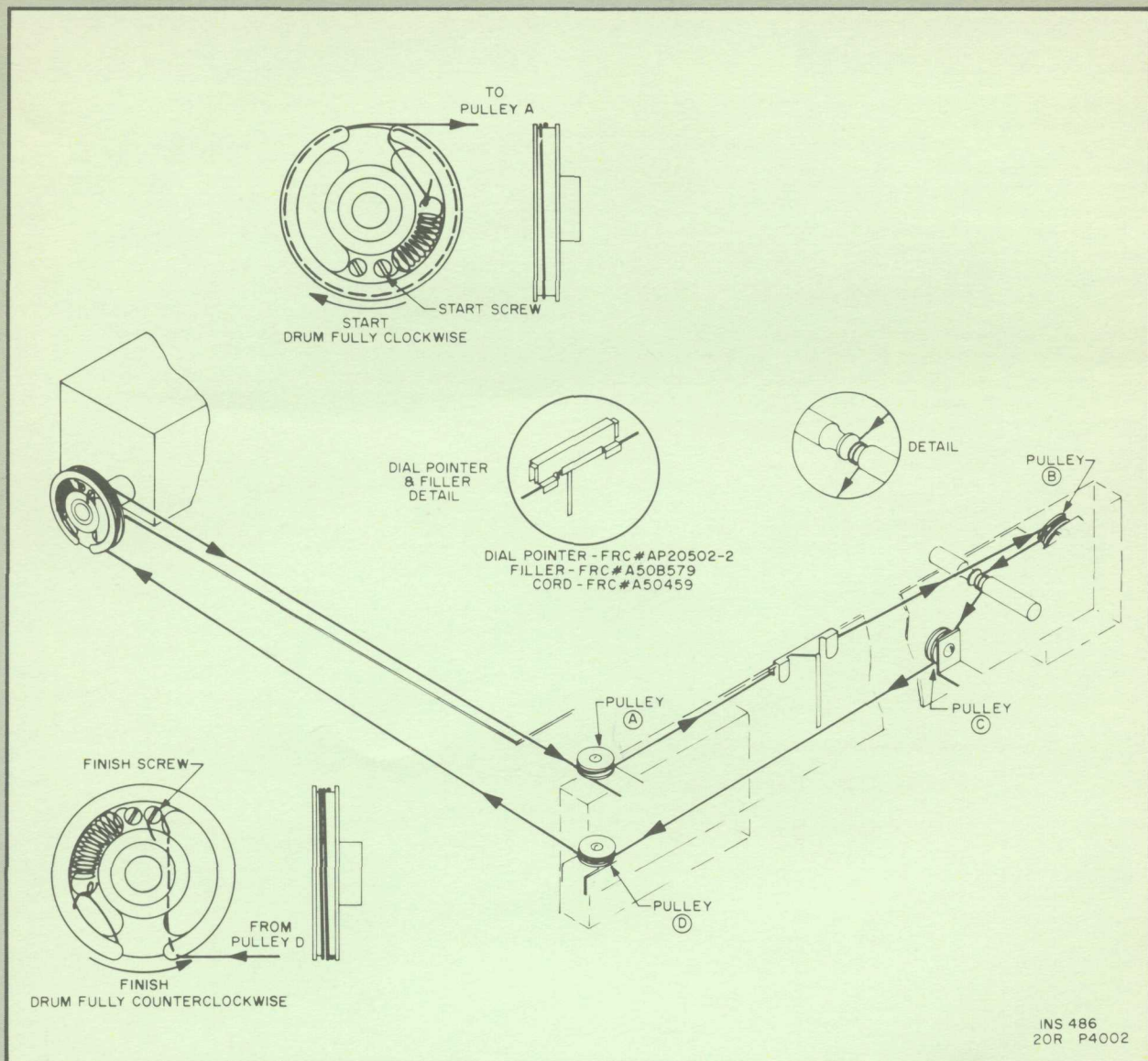

Figure 1.

## DIAL STRINGING

- (1) Remove the two dial lamp holders from their mounting clips.
- (2) Remove the dial pointer from the dial cord.
- (3) Rotate the tuning capacitor drive-drum fully CW. Loosen the START screw. See detail, Figure 1.
- (4) Tie end of dial cord to one end of spring. Fasten spring to START screw and tighten screw.
- (5) Run the dial cord through the slot in the rim of the drive-drum, pull cord taut and make one turn CW around drum.
- (6) Guide dial cord around pulley "A", across the front of the chassis and over the top of pulley "B".
- (7) Pull dial cord taut and wrap 2 turns CW around the tuning shaft. See detail, Figure 1.
- (8) Guide the dial cord under pulley "C" and around pulley "D".
- (9) Rotate the drive-drum fully CCW, allowing the cord to wind onto the drive-drum. Dial cord must be kept taut during this procedure.
- (10) Guide the cord under the drive-drum and under the FINISH screw. See detail, Figure 1. Draw cord taut; tie cord around the screw and tighten the screw.
- (11) Turn the tuning shaft fully CW and CCW to distribute the tensioning along the dial cord.
- (12) Install dial lamp holders.
- (13) Place the dial cord over and under the tabs on the rear of the dial pointer (see detail), and place the pointer on the top of the dial glass panel.
- (14) Turn the tuning shaft fully CCW. Slide dial pointer to zero (0) calibration mark on the logging scale while holding tuning shaft fully CCW. Cement dial pointer to dial cord to prevent slippage. Allow cement to thoroughly dry.



REPLACING DIAL LAMPS

**CAUTION:** When removing dial lamps, avoid hitting the dial cord with lamp holders.

(1) Remove left hand dial lamp mounting clip from front panel by squeezing the clip. Remove lamp and shield from holder. Install shield and new lamp in holder and install mounting clip in front panel.

(2) Rotate right hand dial lamp housing 90° CCW. Remove lamp and shield from holder. Install shield and lamp in holder. Rotate holder 90° CW.

REPLACING STEREO BEACON LAMP

(1) Remove the two top clips holding the dial glass and remove the glass.

(2) Disconnect the STEREO BEACON lamp leads at the terminal strip. Note wiring.

(3) Remove STEREO BEACON assembly from front of panel.

(4) Reverse procedure to install new lamp assembly.

CHASSIS LAYOUT

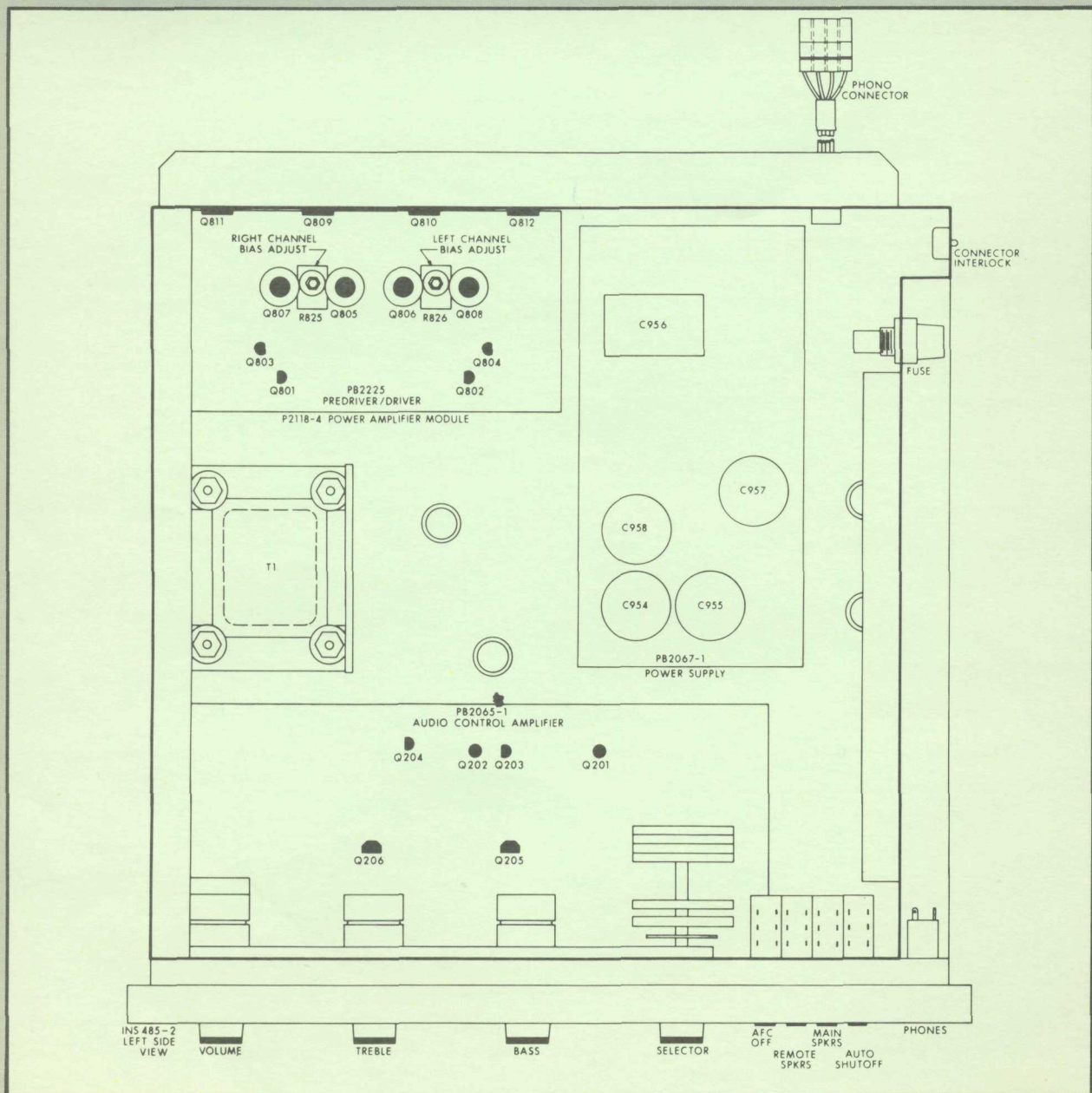



## HARMONIC DISTORTION TEST

## CAUTION:

- (A) Measure the power of one channel at a time.  
 (B) Limit measurements to 10 minutes.  
 (C) Use a load resistor with a minimum rating of 50 watts. Set BASS and TREBLE controls to NORMAL. Set SELECTOR switch to AUX. Depress MAIN SPEAKERS switch. Unplug AC power cord.
- (1) Connect a low-distortion sine-wave generator to the LEFT AUX IN jack. Set generator frequency to 1,000 Hz, and output level to minimum.
- (2) Connect an 8-ohm load resistor across the L MAIN SPEAKER jack. In parallel with the load resistor, connect the input leads of an HD analyzer and the input leads of an accurately calibrated AC VTVM.

- (3) Connect AC power cord and rotate VOLUME control to maximum.
- (4) Increase generator level for 12 watts output (9.7 V RMS across 8-ohm load). HD meter should read 1% or less.
- (5) Repeat preceding steps for right channel.

## REMOVING P.C. BOARDS

To remove a board from its nylon mounts, squeeze the loop of each mounting clip (using pliers), and lift each corner of the board. To remount the board, align the mounting holes over the clips and press firmly.

## CHASSIS LAYOUT

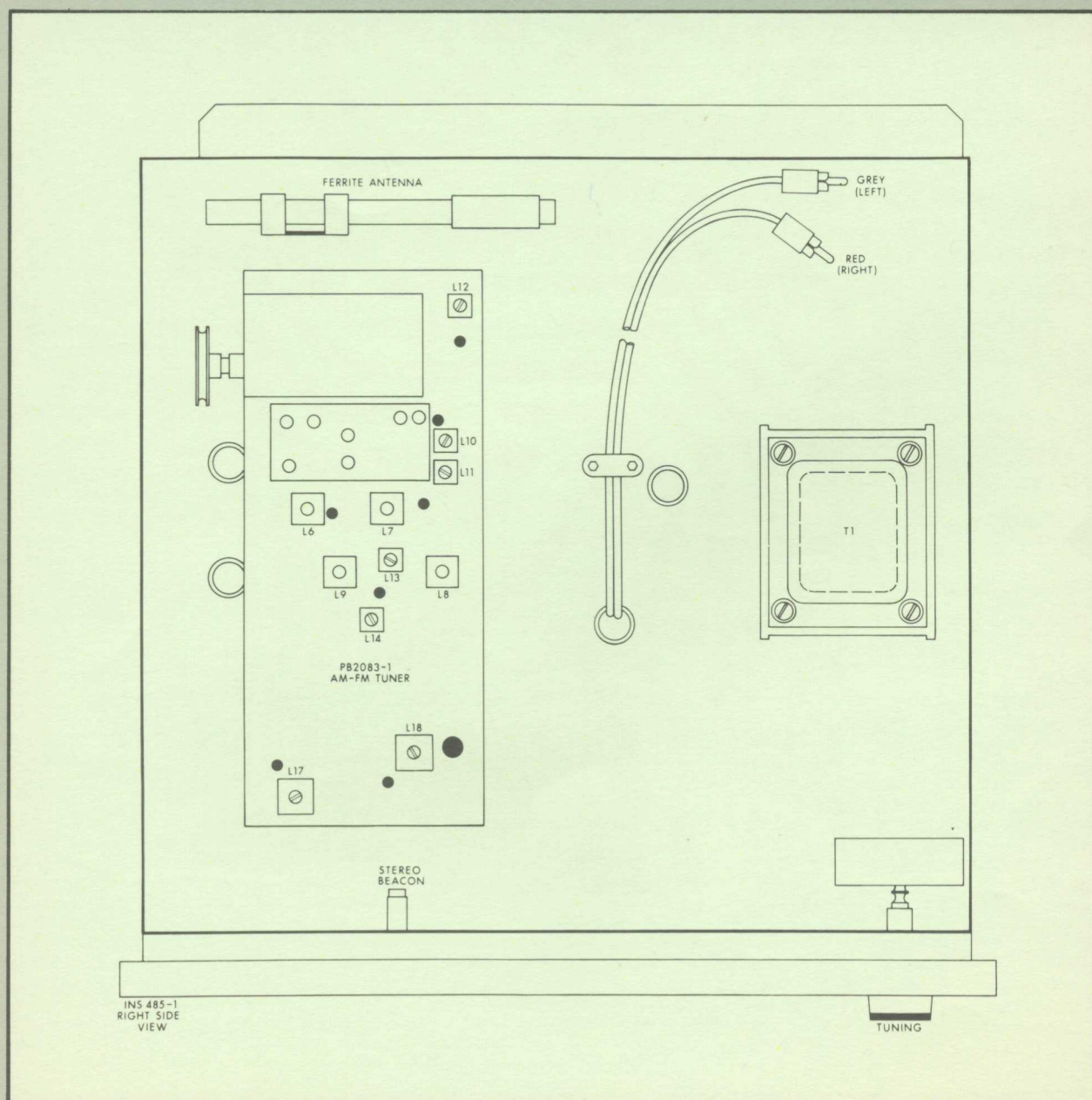



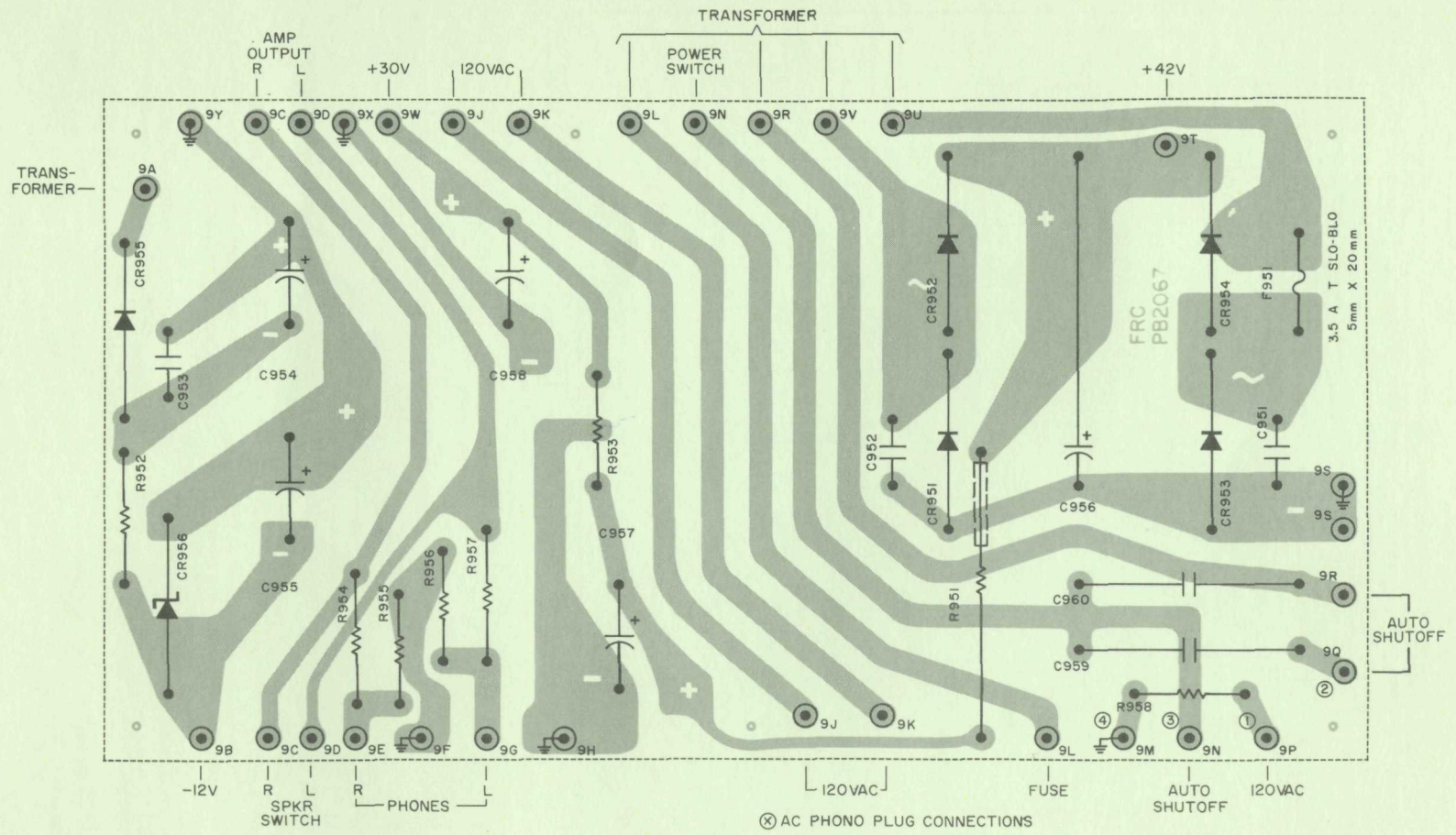

AL2067-111A  
P2067



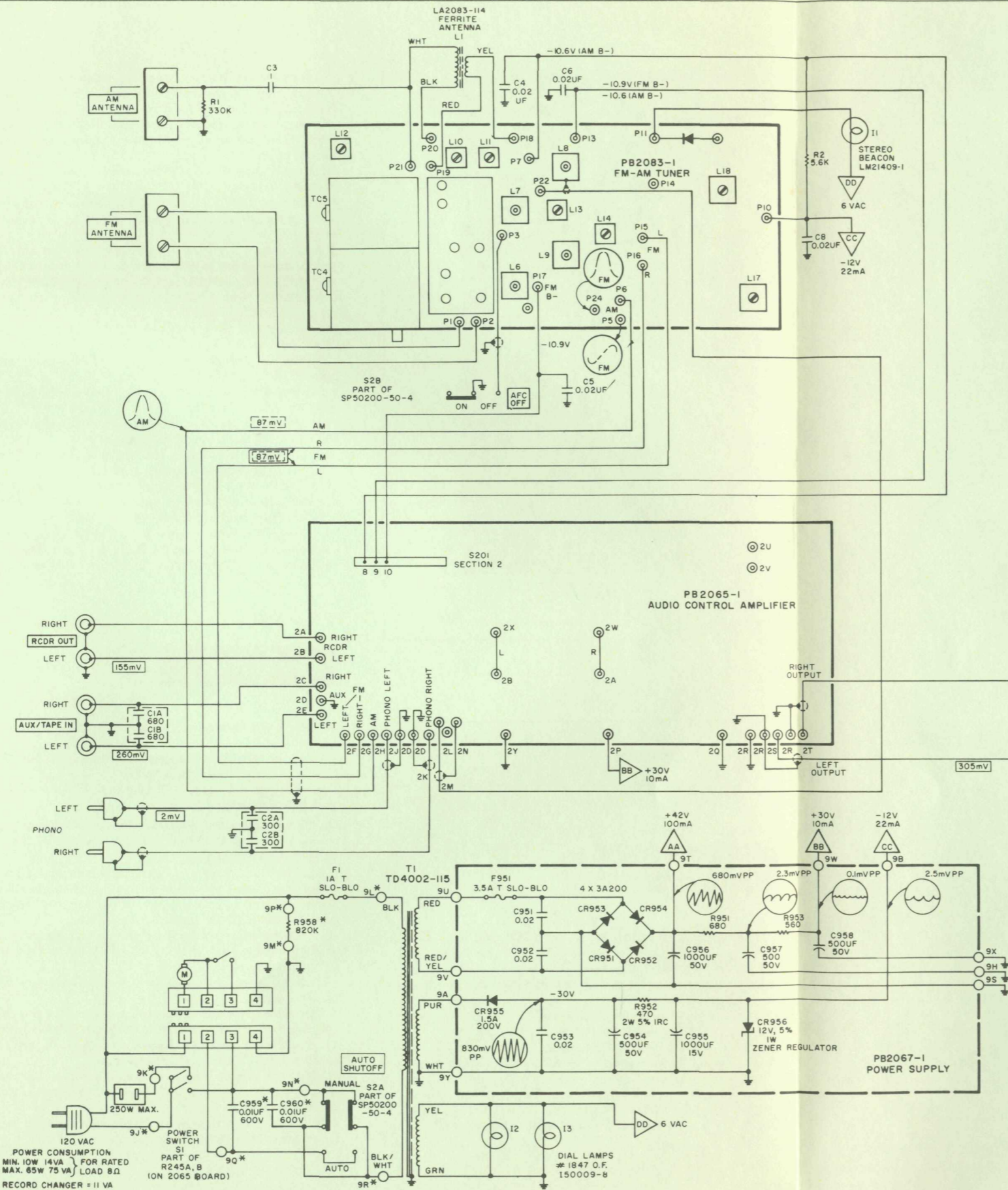

POS	S201 SELECTOR SWITCH
1	PHONO
2	FM
3	AM
4	AUX TAPE

NOTES:

1. FISHER PART NUMBER LISTED FOR PARTS SPECIALLY SELECTED FOR FISHER RADIO CORP.; 1/2 WATT, 5% COMPOSITION RESISTORS MAY BE USED FOR RESISTOR REPLACEMENTS, EXCEPT AS NOTED.
2. ROTARY SWITCH SHOWN IN MAXIMUM CCW POSITION, ALL OTHER CONTROLS AND SWITCHES SHOWN IN NORMAL OPERATING POSITIONS.
3. FOR ALL DC VOLTAGE AND CURRENT MEASUREMENTS, LINE VOLTAGE 120 VAC. ALL DC VOLTAGES MEASURED WITH DC VTVM TO CHASSIS WITH NO SIGNAL INPUT. ALL DC CURRENTS MEASURED WITH MILLIAMMETER WITH NO SIGNAL INPUT.
4. [Symbol] INDICATES 1kHz SIGNAL LEVELS BETWEEN AUDIO INPUTS AND POWER AMPLIFIER OUTPUT MEASURED WITH AC VTVM; VOLUME CONTROL MAXIMUM, ALL OTHER CONTROLS AND SWITCHES NORMAL.
5. [Symbol] INDICATES 1kHz SIGNAL LEVELS MEASURED IN AM WITH GENERATOR SIGNAL = 1MHz, 10mV, AND 12% MODULATION.
6. [Symbol] INDICATES 1kHz SIGNAL LEVELS MEASURED IN FM-MONO WITH GENERATOR SIGNAL = 100MHz, 1mV, ±15kHz DEVIATION.
7. ALL VOLTAGES AND CURRENTS INDICATED MAY VARY ±10%.

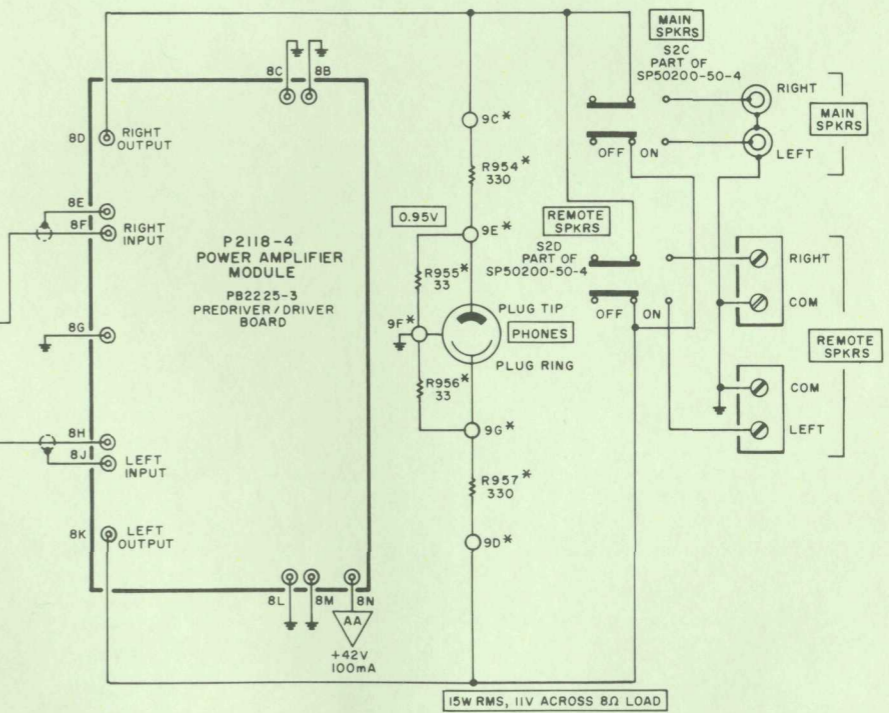

\* MOUNTED ON POWER SUPPLY BOARD 2067

AW 2824  
P4002 (20R)

POWER CONSUMPTION  
MIN. 10W 14VA FOR RATED  
MAX. 65W 75VA LOAD 8Ω  
RECORD CHANGER = 11 VA



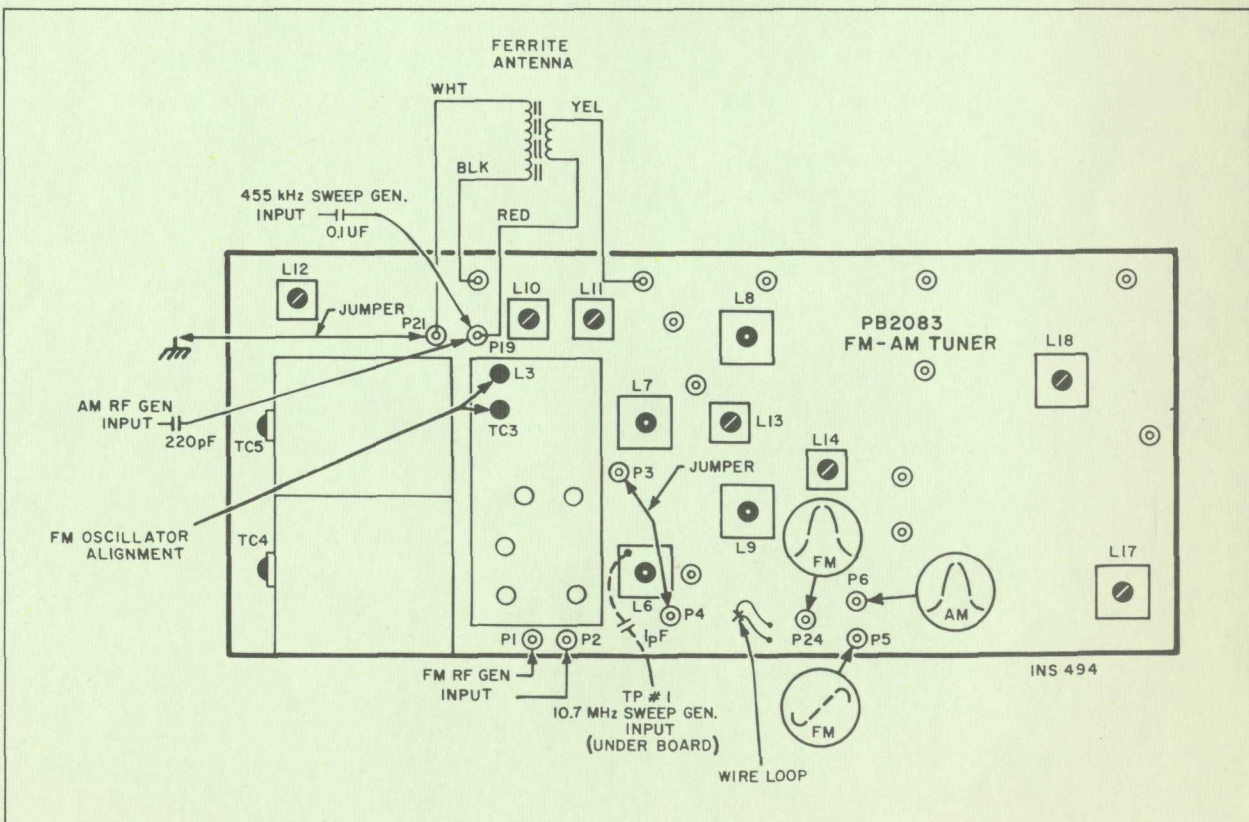
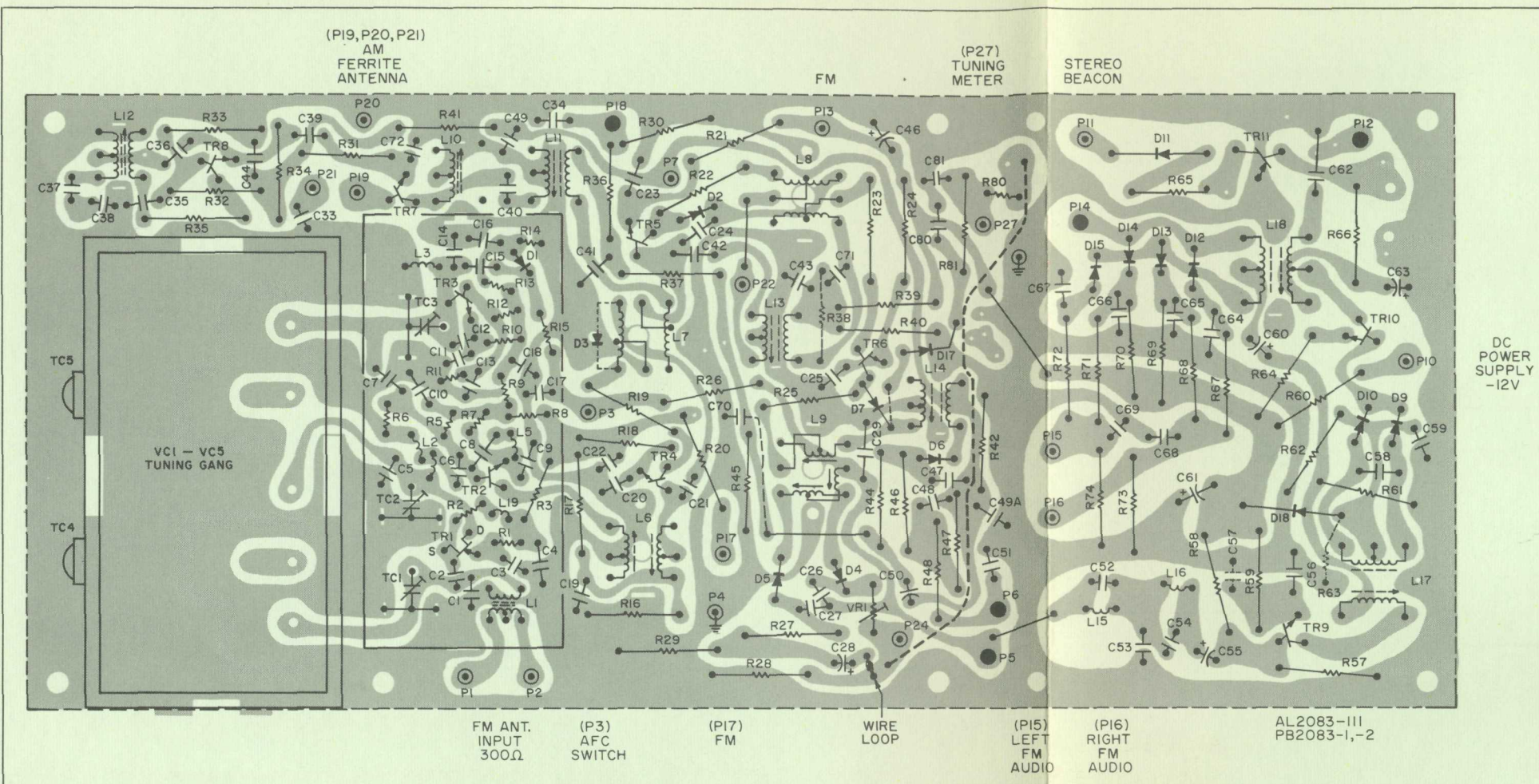

- (6) Set generator frequency and dial pointer accurately to 90MHz. Modulate generator with 400Hz,  $\pm 75$ kHz deviation. Bend oscillator coil L3 for maximum amplitude at P5.
- (7) Set generator frequency and dial pointer accurately to 106MHz. Adjust oscillator trimmer TC3 for maximum amplitude at P5.
- (8) Repeat steps (6) and (7) for maximum sensitivity and accurate dial calibration.
- (9) Reconnect DC VTVM to P5. Set generator level to 1 mV. Tune receiver to generator frequency (106MHz) for 0 VDC at P5.
- (10) Connect AC VTVM and scope to RIGHT RCDR OUT jack. Connect MPX generator composite output to FM generator EXTERNAL MODULATION input. Modulate left and right channels with 400Hz, ( $\pm 75$ kHz deviation) and 19kHz pilot ( $\pm 7.5$ kHz deviation).
- (11) Adjust top cores of L17 and L18 for maximum audio. Note audio level.
- (12) Modulate left channel only. AC VTVM should read at least 20 dB below level noted in step (11).
- (13) Reconnect AC VTVM and scope to LEFT RCDR OUT jack. Note audio level.
- (14) Modulate right channel only. AC VTVM should read at least 20 dB below level noted in step (13).
- (15) Disconnect MPX generator. Set generator output to 20 mV, and modulate with 400Hz,  $\pm 75$ kHz deviation.
- (16) Detune generator frequency for +0.5 VDC at P5. Disconnect jumper between P3 and P4 to turn AFC on. DC VTVM should read between +0.5 and 0 VDC.
- (17) Reconnect jumper between P3 and P4. Detune generator frequency for -0.5 VDC at P5. Remove jumper. Meter should read between -0.5 and 0 VDC. Disconnect test equipment.

**AM ALIGNMENT**

- (1) Set SELECTOR switch to AM. Turn VOLUME control to minimum.
- (2) Connect 455kHz sweep generator through 0.1 $\mu$ F to P19. Connect scope through 220k to P6.
- (3) Adjust cores of L14, L13, L11 and L10 for maximum gain and symmetry.
- (4) Disconnect sweep generator. Connect AM signal generator through 220pF to P19. Connect scope and AC VTVM to RIGHT RCDR OUT jack.
- (5) Set generator frequency and dial pointer accurately to 600kHz. Modulate generator with 400Hz, 30% modulation. Connect a short jumper between P21 and chassis. Adjust oscillator coil L12 for maximum amplitude.
- (6) Set generator frequency and dial pointer accurately to 1400kHz. Adjust oscillator trimmer TC5 for maximum amplitude.
- (7) Repeat steps (5) and (6) for accurate dial calibration and maximum gain.
- (8) Disconnect jumper connection between P21 and chassis. Reconnect AM signal generator to AM ANTENNA terminal. Tune receiver to generator frequency at 600kHz. Modulate generator with 400Hz, 30% modulation.
- (9) Melt the wax holding the coil to the ferrite antenna. Shift the coil for maximum audio indication. To secure coil in position, remelt wax.
- (10) Tune receiver to generator frequency at 1400kHz. Adjust antenna trimmer TC4 for maximum audio.

Turn TUNING knob fully CCW. If pointer is not centered on (0), reposition and cement pointer. Except as noted, maintain generator level as low as possible during alignment.

**FM ALIGNMENT**

- (1) Set SELECTOR switch to FM. Turn VOLUME control to minimum. Connect jumper between P3 and P4 to defeat AFC.
- (2) Connect 10.7MHz sweep generator through 1pF to Test Point 1. Connect scope through 220k to P24. Cut wire loop at P24.
- (3) Adjust top and bottom cores of L8, L7, and L6, and bottom core of L9 for maximum gain and symmetry.
- (4) Reconnect wire loop at P24. Reconnect scope to P5. Adjust top and bottom cores of L9 for maximum linear amplitude.
- (5) Connect DC VTVM to P5. Readjust top core of L9 for 0 VDC. Disconnect sweep generator and DC VTVM. Connect FM RF generator through 120-ohm carbon resistors to P1 and P2.



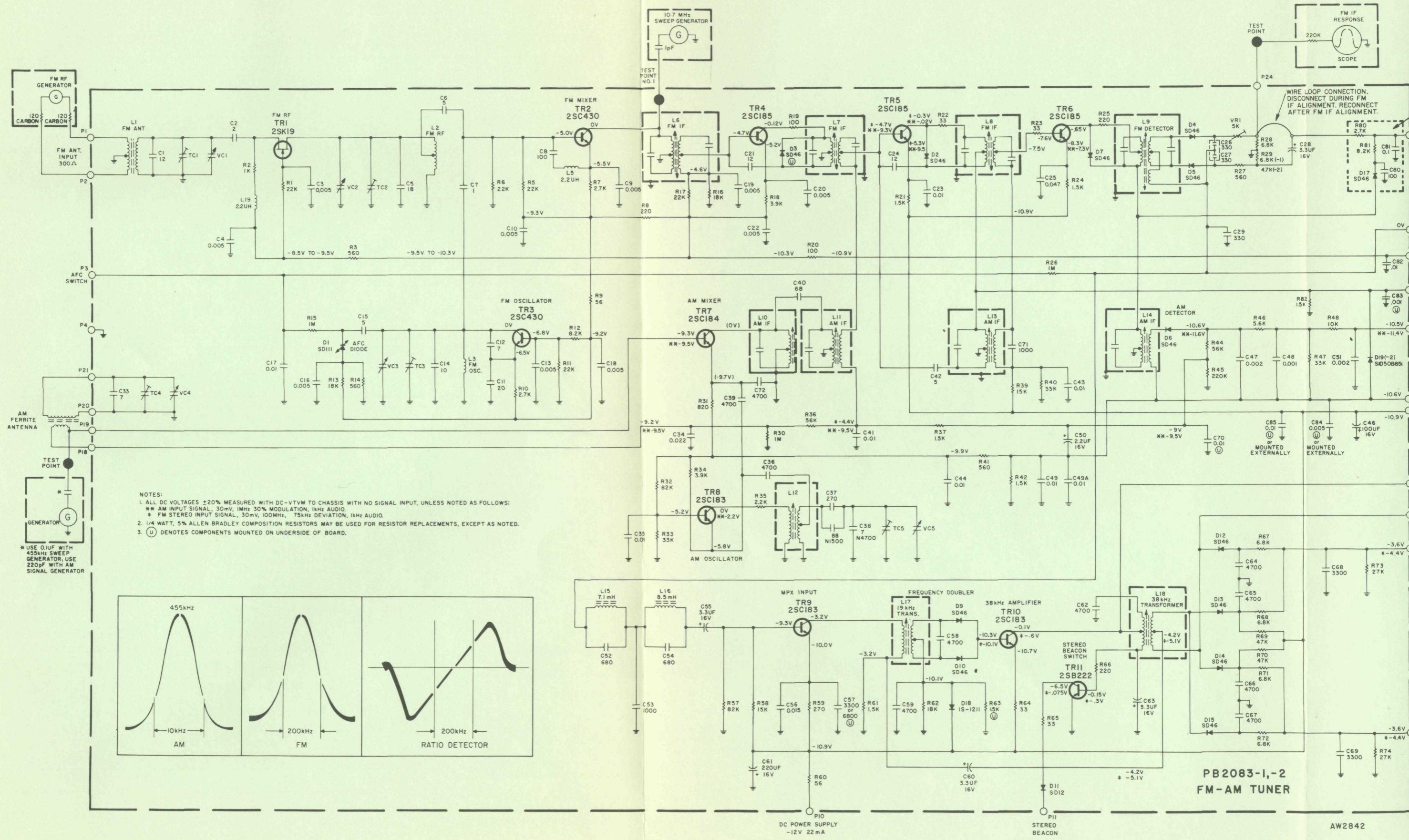

- NOTES:
1. ALL DC VOLTAGES  $\pm 20\%$  MEASURED WITH DC-VTVM TO CHASSIS WITH NO SIGNAL INPUT, UNLESS NOTED AS FOLLOWS:  
 \*\* AM INPUT SIGNAL, 30mV, 1MHz 30% MODULATION, 1kHz AUDIO.  
 \* FM STEREO INPUT SIGNAL, 30mV, 100MHz, 75kHz DEVIATION, 1kHz AUDIO.
  2. 1/4 WATT, 5% ALLEN BRADLEY COMPOSITION RESISTORS MAY BE USED FOR RESISTOR REPLACEMENTS, EXCEPT AS NOTED.
  3. (U) DENOTES COMPONENTS MOUNTED ON UNDERSIDE OF BOARD.

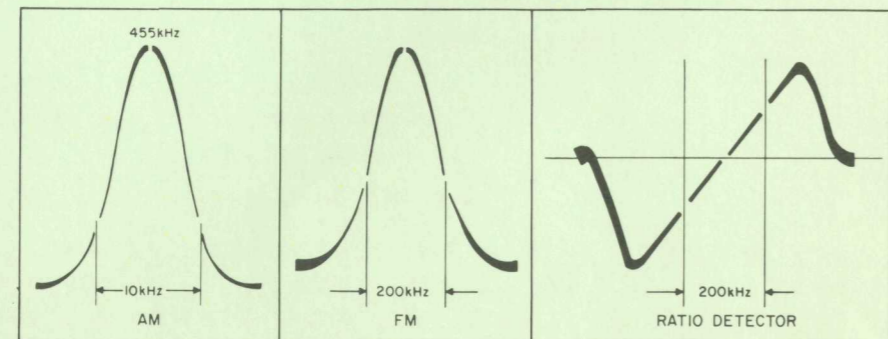

**PB2083-1, 2  
FM-AM TUNER**



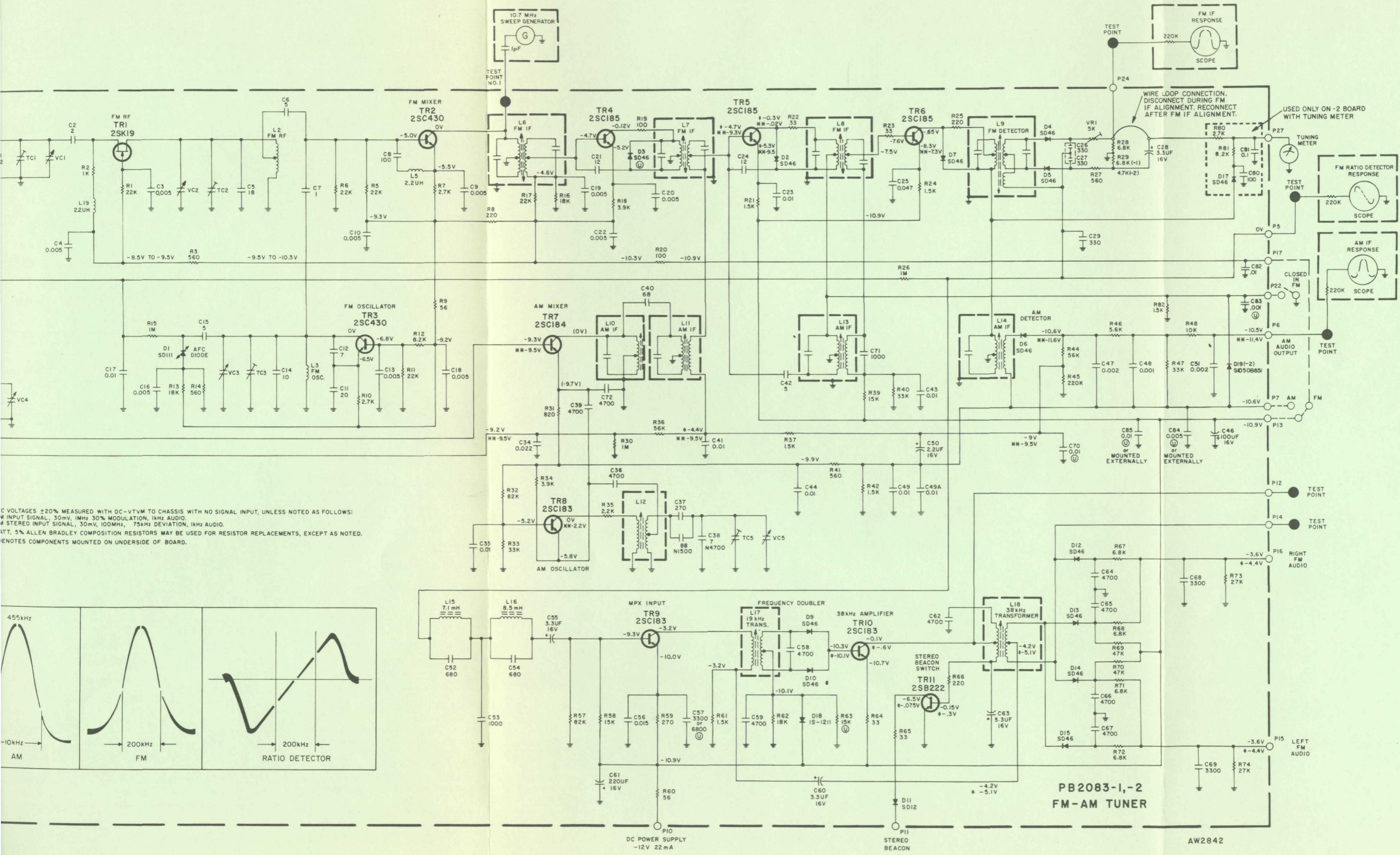

C VOLTAGES ±20% MEASURED WITH DC-VTM TO CHASSIS WITH NO SIGNAL INPUT, UNLESS NOTED AS FOLLOWS:  
 \* M INPUT SIGNAL, 30mV, 1MHz 30% MODULATION, 1kHz AUDIO.  
 \* S STEREO INPUT SIGNAL, 30mV, 100MHz, 75kHz DEVIATION, 1kHz AUDIO.  
 \* TT, 5% ALLEN BRADLEY COMPOSITION RESISTORS MAY BE USED FOR RESISTOR REPLACEMENTS, EXCEPT AS NOTED.  
 \* Ⓧ NOTES COMPONENTS MOUNTED ON UNDERSIDE OF BOARD.

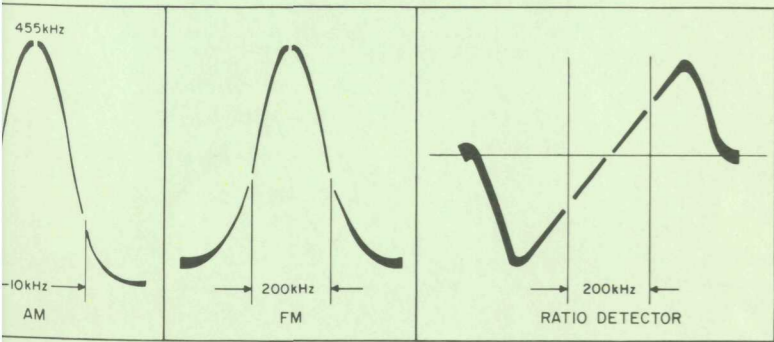

P10 DC POWER SUPPLY -12V 22mA

P11 STEREO BEACON

P12 TEST POINT

P14 TEST POINT

P16 RIGHT FM AUDIO

P15 LEFT FM AUDIO



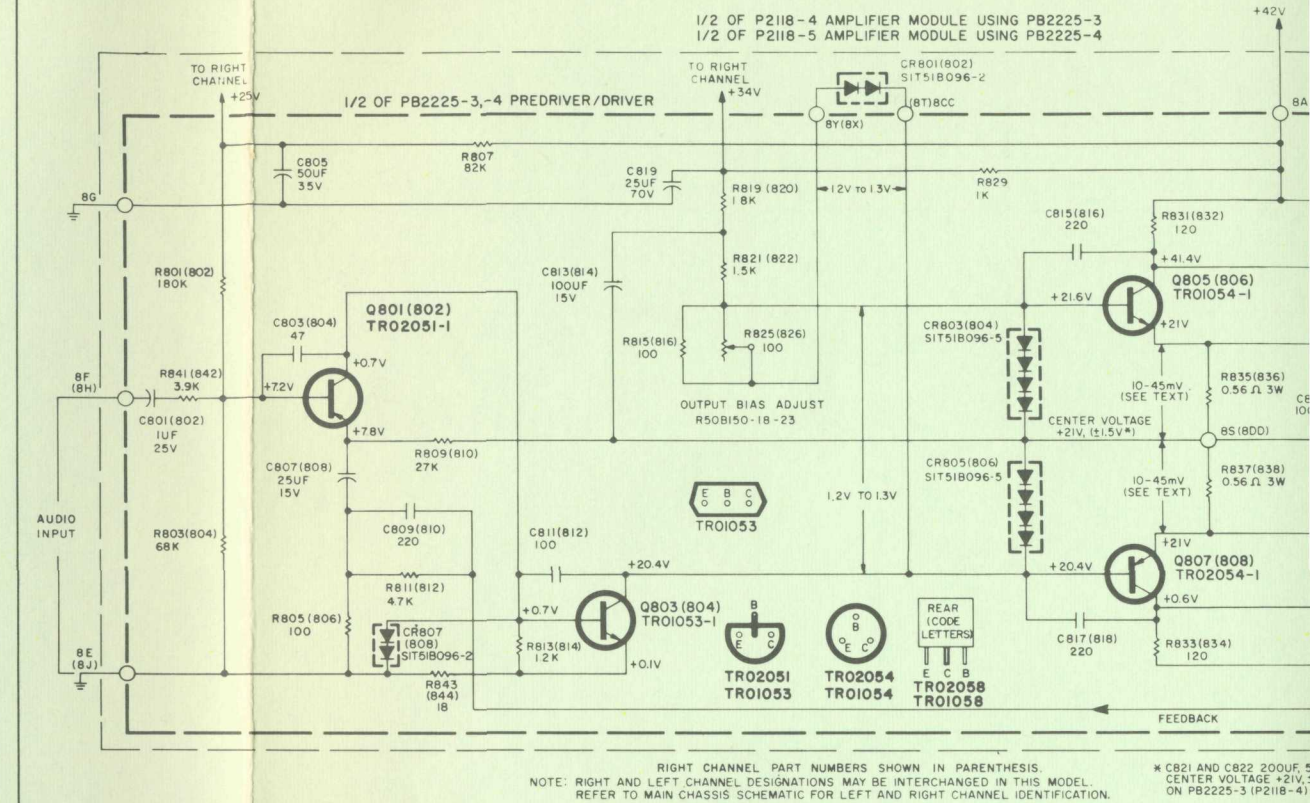
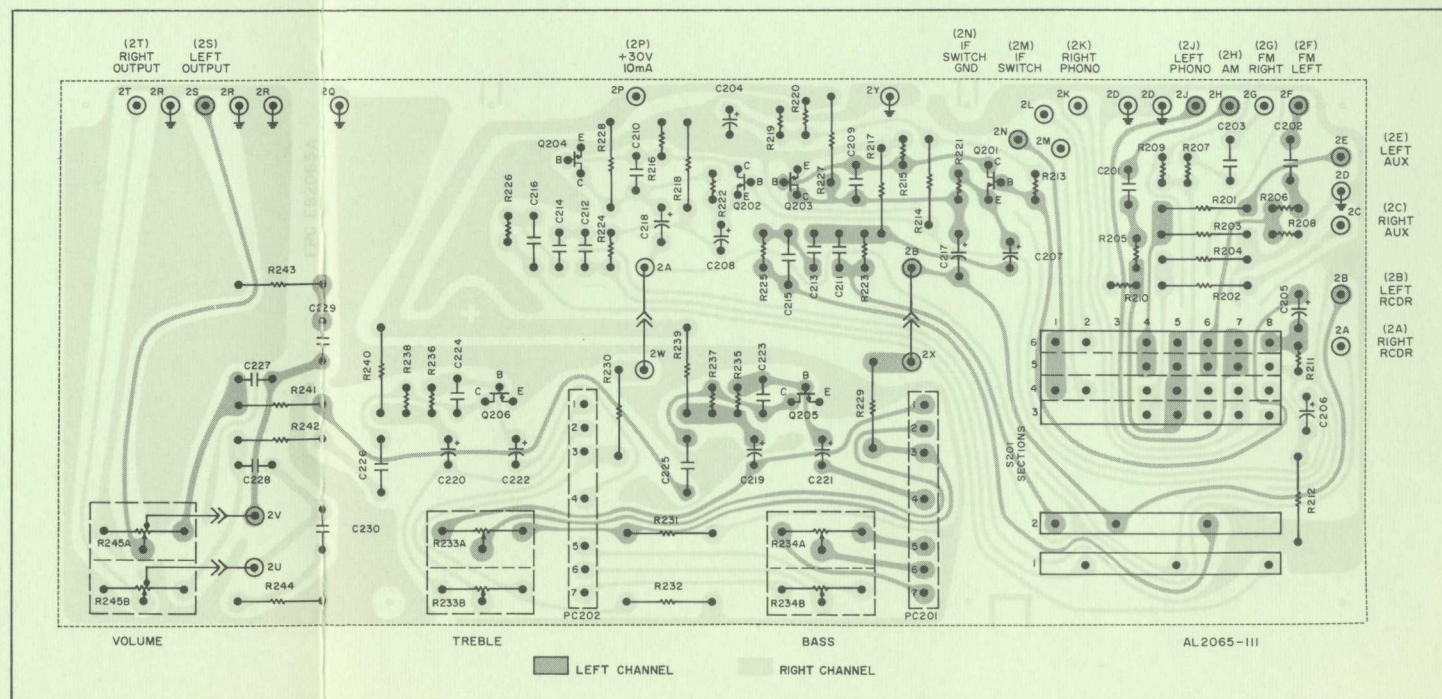
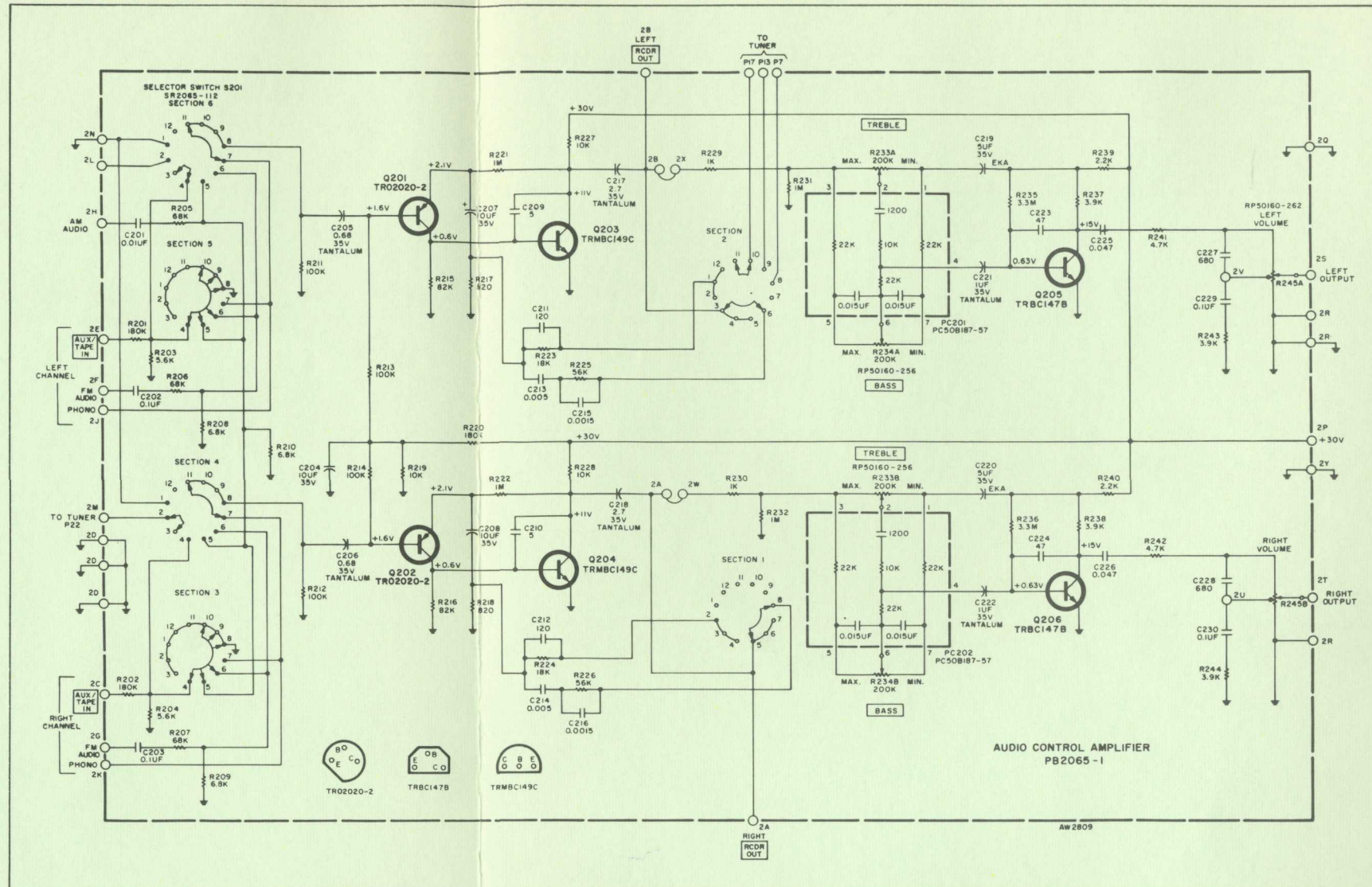

NOTE: RIGHT AND LEFT CHANNEL DESIGNATIONS MAY BE INTERCHANGED IN THIS MODEL. REFER TO MAIN CHASSIS SCHEMATIC FOR LEFT AND RIGHT CHANNEL IDENTIFICATION.

**CENTER VOLTAGE TEST**

- Turn VOLUME control to minimum. Depress MAIN SPEAKERS switch.
- (1) Connect two 8-ohm resistors across the L and R MAIN SPEAKERS jacks; one resistor to each jack.
  - (2) Temporarily connect two 10k ± 1% resistors in series between pins 9T and 9S (on Power Supply board). Connect the common lead of a DC VTVM to the junction of the resistors.
  - (3) Connect the probe of the DC VTVM to pin 8S (on Power Amplifier Module). Meter should read 0 VDC (± 2 volts).
  - (4) Reconnect the probe of the meter to pin 8DD. Meter should read 0 VDC (± 2 volts).
  - (5) Disconnect the two 10k resistors.

**IDLING CURRENT ADJUSTMENT**

- Turn unit on, and warm up thoroughly (approximately 10 minutes). Turn VOLUME control to minimum.
- (1) Connect the common lead of a DC VTVM to pin 8S (on Power Amplifier Module). Connect the probe of the meter to pin 8AA. BE CAREFUL TO AVOID SHORTING ADJACENT PINS. Meter should read between 10mV and 45mV.
  - (2) If necessary, reset BIAS ADJUST pot. R825 (on Power Amplifier Module). Optimum amplifier performance will be achieved with 15mV setting.
  - (3) Reconnect the common lead of the meter to pin 8DD. Reconnect meter probe to pin 8V. BE CAREFUL TO AVOID SHORTING ADJACENT PINS. Meter should read between 10mV and 45mV.
  - (4) If necessary, reset BIAS ADJUST pot. R826.

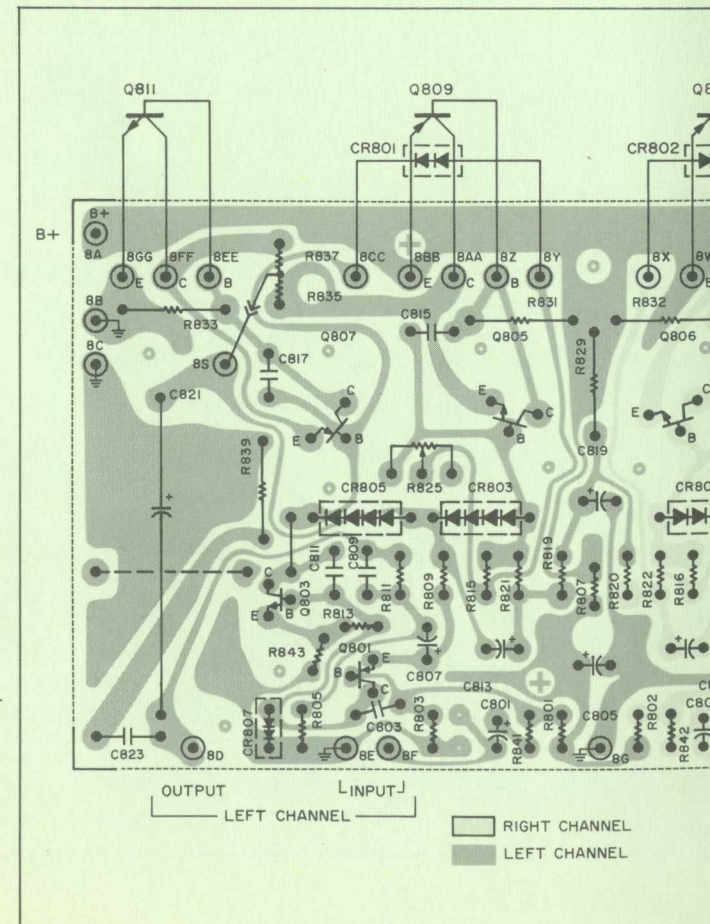



### 2118-4 POWER AMPLIFIER MODULE

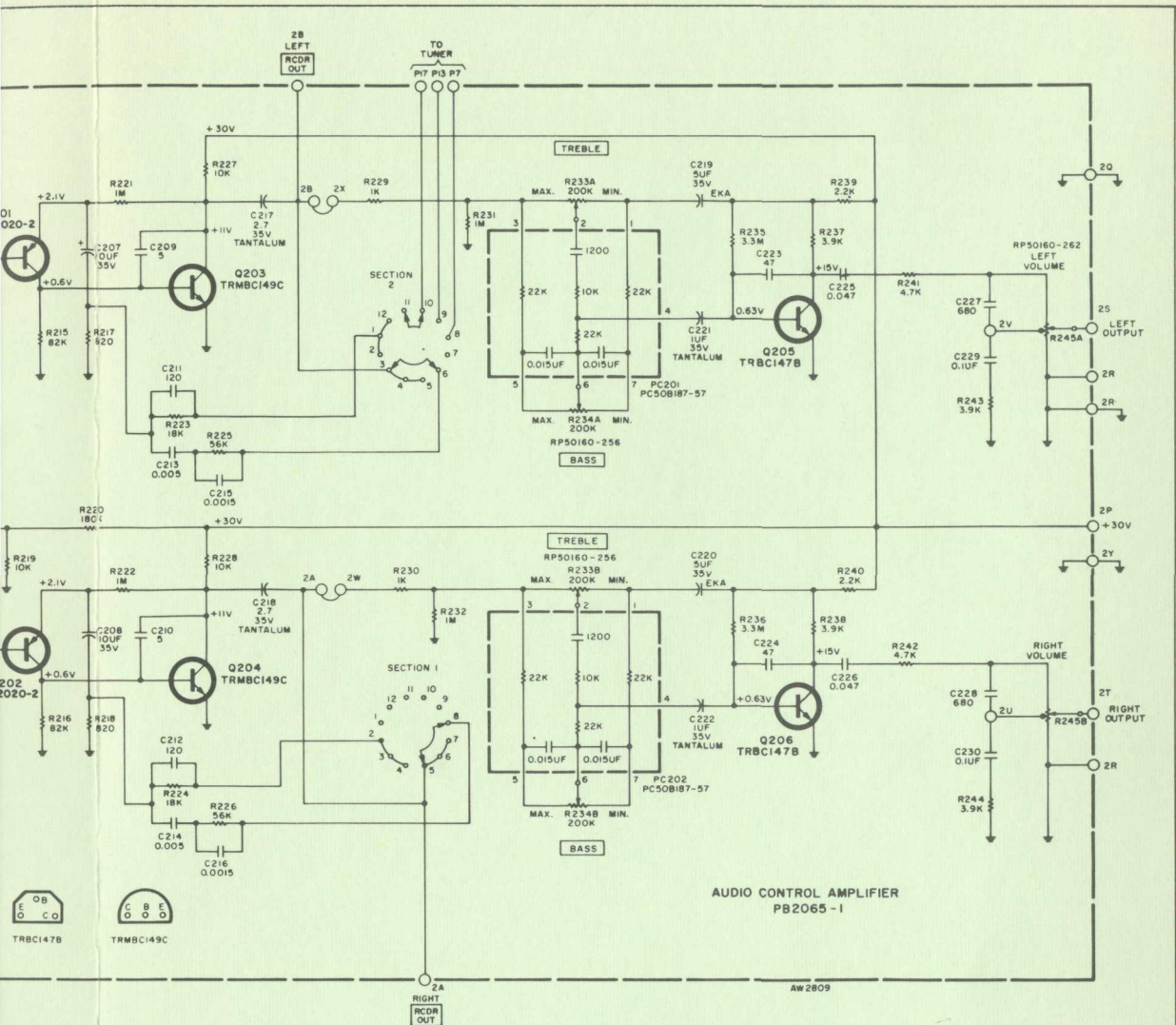

AUDIO CONTROL AMPLIFIER PB2065-1

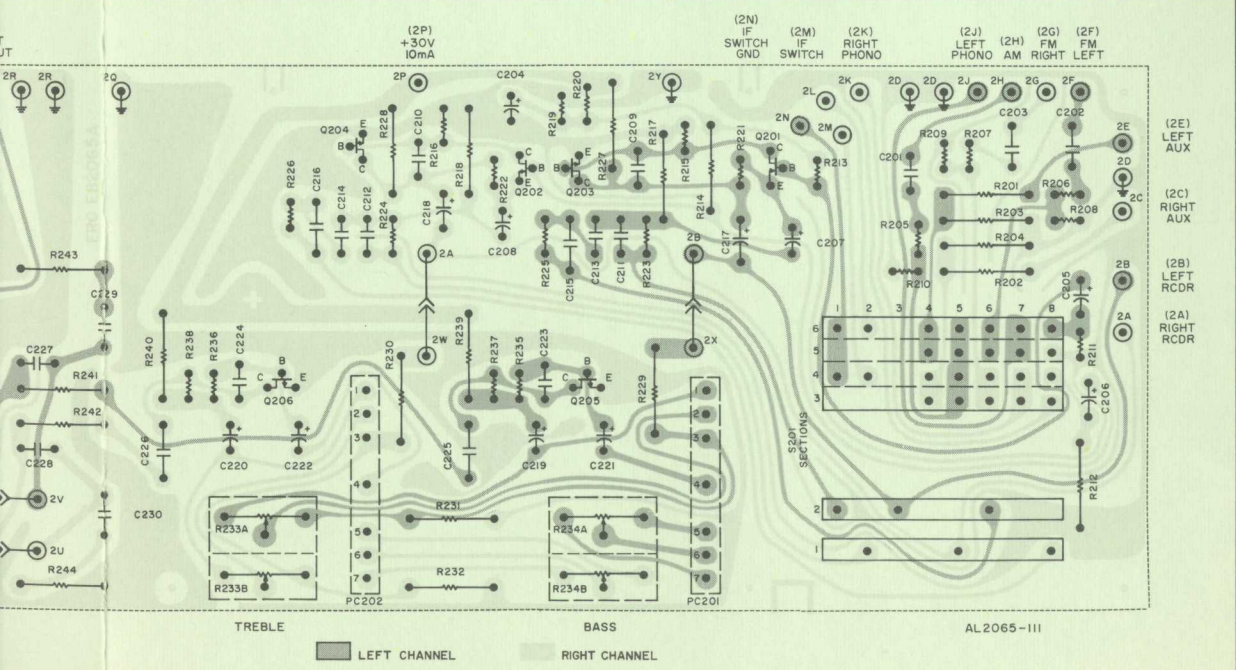

AL2065-111

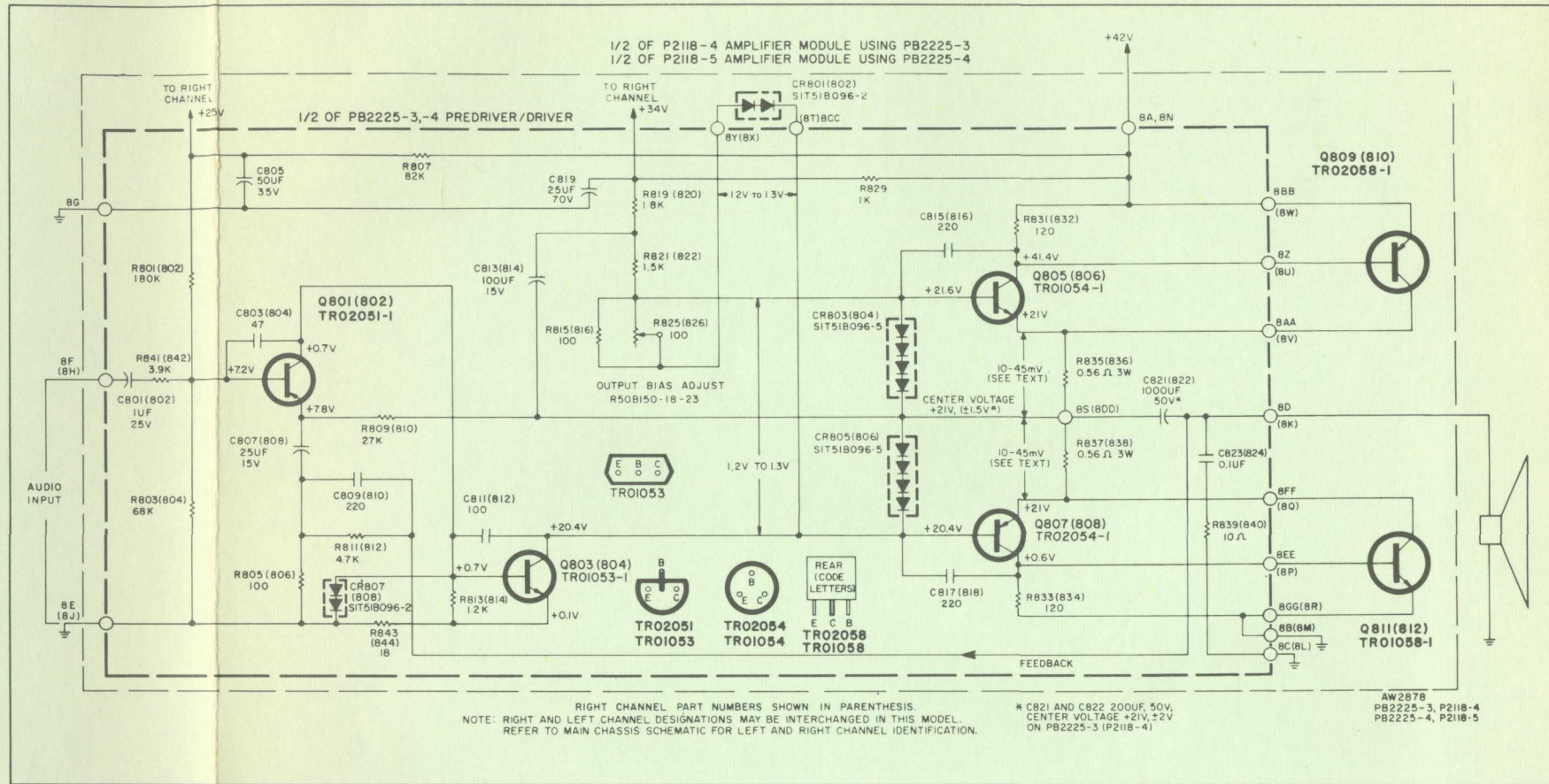

NOTE: RIGHT AND LEFT CHANNEL DESIGNATIONS MAY BE INTERCHANGED IN THIS MODEL. REFER TO MAIN CHASSIS SCHEMATIC FOR LEFT AND RIGHT CHANNEL IDENTIFICATION.

\* C821 and C822 200UF, 50V, CENTER VOLTAGE +21V, ±2V ON PB2225-3 (P2118-4) PB2225-4, P2118-5

### CENTER VOLTAGE TEST

- Turn VOLUME control to minimum. Depress MAIN SPEAKERS switch.
- (1) Connect two 8-ohm resistors across the L and R MAIN SPEAKERS jacks; one resistor to each jack.
  - (2) Temporarily connect two 10k ± 1% resistors in series between pins 9T and 9S (on Power Supply board). Connect the common lead of a DC VTVM to the junction of the resistors.
  - (3) Connect the probe of the DC VTVM to pin 8S (on Power Amplifier Module). Meter should read 0 VDC (± 2 volts).
  - (4) Reconnect the probe of the meter to pin 8DD. Meter should read 0 VDC (± 2 volts).
  - (5) Disconnect the two 10k resistors.

### IDLING CURRENT ADJUSTMENT

- Turn unit on, and warm up thoroughly (approximately 10 minutes). Turn VOLUME control to minimum.
- (1) Connect the common lead of a DC VTVM to pin 8S (on Power Amplifier Module). Connect the probe of the meter to pin 8AA. BE CAREFUL TO AVOID SHORTING ADJACENT PINS. Meter should read between 10mV and 45mV.
  - (2) If necessary, reset BIAS ADJUST pot. R825 (on Power Amplifier Module). Optimum amplifier performance will be achieved with 15mV setting.
  - (3) Reconnect the common lead of the meter to pin 8DD. Reconnect meter probe to pin 8V. BE CAREFUL TO AVOID SHORTING ADJACENT PINS. Meter should read between 10mV and 45mV.
  - (4) If necessary, reset BIAS ADJUST pot. R826.

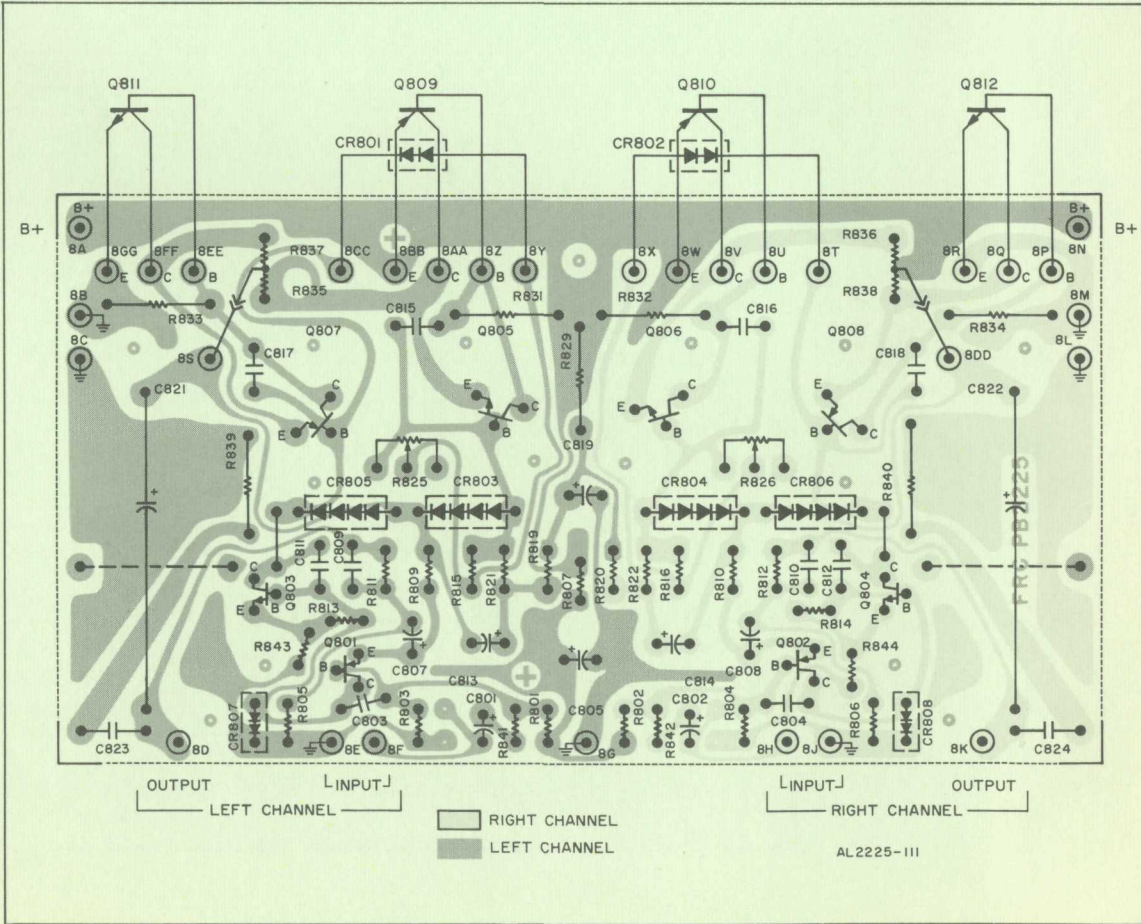

AL2225-111



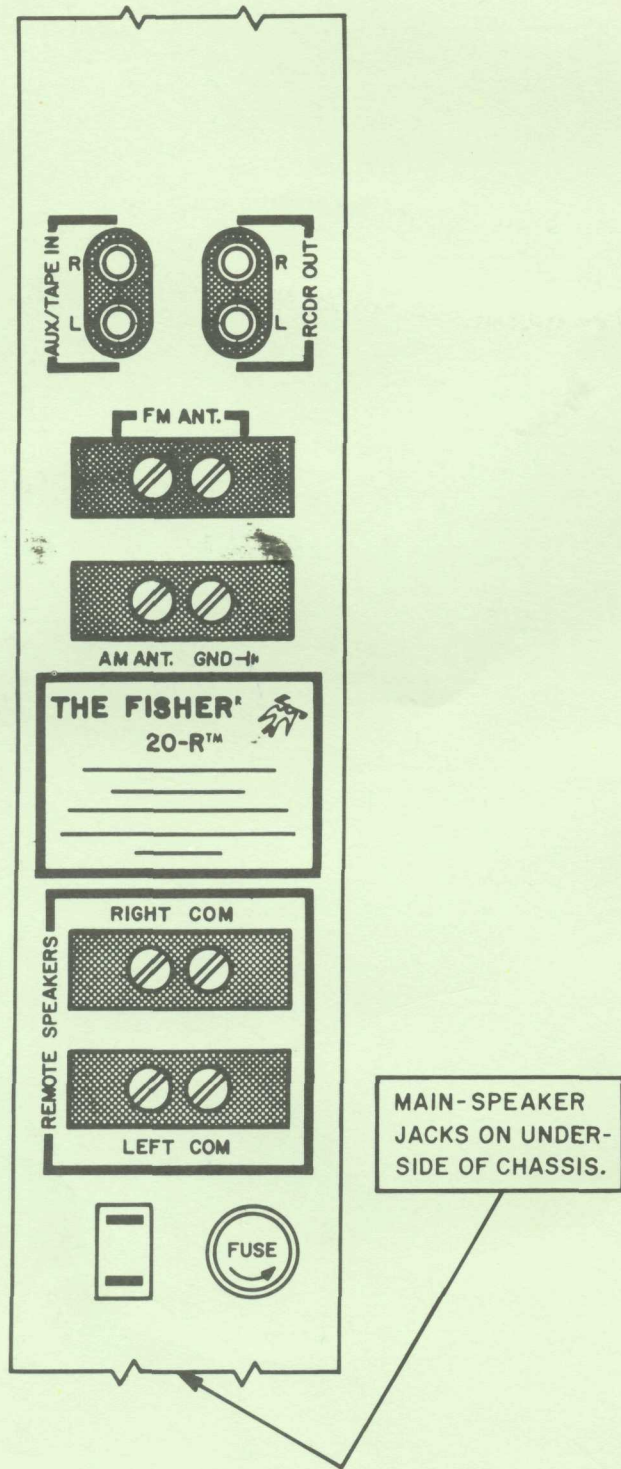

AL4002-131



FISHER RADIO • LONG ISLAND CITY • NEW YORK 11101

