

SERVICE MANUAL

PRICE \$1.00

250-TX

SERIAL NUMBERS
FROM 73896



The Fisher[®]

250-TX[™]

24RX CONSOLE CHASSIS

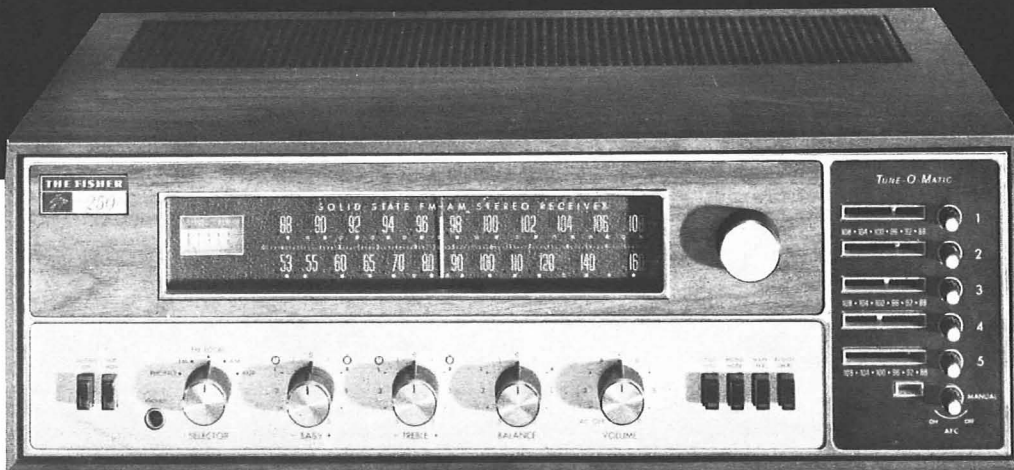

WORLD LEADER IN HIGH QUALITY STEREO

TEST EQUIPMENT AND SERVICE TIPS

The following equipment is required to completely test and align modern high-fidelity amplifiers, tuners, and receivers.

Line Voltage Autotransformer or Voltage Regulator	10.7 MHz Sweep Generator
DC Vacuum Tube Voltohmmeter	Multiplex Generator (preferably with RF output)
Accurately Calibrated AC Vacuum Tube Voltmeter	455 kHz Sweep Generator
Oscilloscope ((Flat to 100 kHz Minimum)	Ferrite Test Loop Stick
Low-Distortion Audio (Sine Wave) Generator	2 – Full Range Speakers for Listening Tests
Intermodulation Distortion Analyzer	Stereo Source – Turntable, Tape Recorder, etc.
Harmonic Distortion Analyzer	Soldering Iron with Small Tip, Fully Insulated from AC Line
2 – Load resistors, 8-Ohms, 100 Watt (Minimum Rating)	Suction Desoldering Tool
AM/FM Signal Generator	

CAUTION: This precision high-fidelity instrument should be serviced only by qualified personnel, trained in the repair of transistor equipment and printed circuitry.

Many of these items are included only as a reminder — they are normal procedures for experienced technicians. Shortcuts may be taken, but these often cause additional damage to transistors, circuit components, or printed circuit boards.

SOLDERING: A well-tinned, hot, clean soldering iron tip will make soldering easier, without causing damage to the printed circuit board or the components mounted on it. Regular use of a sponge cleaner will maintain a clean soldering surface. The heat available at the tip, (not the wattage of the iron) is important. Some 50-watt irons reach temperatures of 1,000° F, while others will hardly melt solder. Small-diameter tips should be used for single solder connections, pyramid and chisel tips for large areas.

Always disconnect the AC power cord from the line when soldering. Turning the power switch OFF is not sufficient. Power-line leakage paths, through the heating element of the iron, may destroy transistors.

PARTS REMOVAL: If a part is not being returned for in-warranty factory replacement, it may be cut in half (with diagonal cutting pliers) to make removal easier. Multiple terminal parts, such as IF transformers, or electrolytic capacitors, should be removed using special de-soldering tips made especially for this purpose. Removing solder from terminals, reduces the possibility of breaking the printed circuit board when the part is removed.

ACCIDENTAL SHORTS: A clean working area, free of metal particles, screws, etc., is an important preventive in avoiding servicing problems. Screws, removed from the chassis during servicing, should be stored in a box until needed. While a set is operating, it takes only an instant for a base-to-collector short to destroy a transistor (and others direct-coupled to it). In the time it takes for a dropped machine screw, washer, or screwdriver, to contact a pair of socket terminals (or terminal and chassis), a transistor can be ruined.

SOLID-STATE DEVICES: Integrated Circuits contain the equivalent of many circuit parts, including transistors, diodes, resistors, and capacitors. The preferred troubleshooting procedure requires isolating the trouble to one stage using AC signal tracing methods. Once the suspected stage is located, the DC voltages at the input and output leads are measured to give an accurate indication of the operating conditions of the IC. DO NOT use an ohmmeter to check continuity with the IC mounted on the printed circuit board. Forward biasing the internal junctions within the IC may burn out the transistors. Do not replace a defective IC until all external resistors, capacitors, and transformers are checked first, to prevent the replacement IC from failing immediately due to a defect in the connecting components. Solder and unsolder each lead separately using a pliers or other heat sink on the lead to prevent damage from excessive heat. Check that the leads are

connected to the correct locations on the printed circuit board before turning the set on.

Whenever possible, a transistor tester should be used to determine the condition of a transistor or diode. Ohmmeter checks do not provide conclusive data, and may even destroy the junction(s) within the device.

Never attempt to repair a transistor power amplifier module until the power supply filter-capacitors are fully discharged.

If an output or driver transistor becomes defective (opens or shorts), always check ALL direct-coupled transistors and diodes in that channel. In addition, check the bias pot., and other parts in the bias network, before installing replacement transistors. All output and driver transistors in one channel may be destroyed if the bias network is defective. After parts replacement, always check the bias adjustment for specified idling current.

In some applications, replacement of transistors must be made from the same beta group as the original type. The beta group is indicated by a colored marking on the transistor. Be sure to include this information when ordering replacement transistors.

When mounting a replacement power transistor, be sure the bottom of the flange, mica insulator, and the surface of the heat sink, are free of foreign matter. Dust and grit will prevent flat contact, reducing heat transfer to the heat sink. Metallic particles can puncture the insulator, cause a short, and destroy the transistor.

Silicone grease must be used between the transistor and the mica insulator, and between the mica and the heat sink, for best heat transfer. Use Dow-Corning DC-3, or an equivalent compound made for power transistor heat conduction.

Use care when making connections to speakers and output terminals. To reduce the possibility of shorts, lugs should be used on the exposed ends, or stranded wire should be tinned to prevent frayed wire ends. Current in the speakers and output circuitry is quite high — poor contacts, or small sized wire, can cause significant power losses in the system. For wire lengths greater than 30 feet, 16 AWG, or heavier, should be used.

VOLTAGE MEASUREMENTS: All voltages are measured with the line voltage adjusted to 120 volts. All measured voltages are $\pm 10\%$. DC voltages are measured to ground with a VTVM, with no signal input unless otherwise noted. AC signal voltages are measured under the conditions specified on the schematic.

ALIGNMENT PROCEDURES: DO NOT attempt realignment unless the required test equipment is available, and the alignment procedure is thoroughly understood.

BECAUSE ITS PRODUCTS ARE SUBJECT TO CONTINUOUS IMPROVEMENT, FISHER RADIO RESERVES THE RIGHT TO MODIFY ANY DESIGN OR SPECIFICATION WITHOUT NOTICE AND WITHOUT INCURRING ANY OBLIGATION.

TABLE OF CONTENTS

MECHANICAL DISASSEMBLY

	PAGE		PAGE
REQUIRED TEST EQUIPMENT	2	CONTROL AMPLIFIER	8
MECHANICAL DISASSEMBLY	3	PREAMPLIFIER	9
DIAL STRINGING	4	FM RF	10
HARMONIC DISTORTION TEST	4	AM RF	11
CHASSIS LAYOUT	5	TUNER ALIGNMENT	12-13
POWER SUPPLY	6	AM-FM IF, MPX, METER, MUTING	14-15
MAIN CHASSIS	7	PUSHBUTTON-SWITCH BOARDS	16
POWER AMPLIFIER	8	TUNE-O-MATIC	16

REMOVING DRESS PANEL

- (1) Unplug AC power cord.
- (2) Remove screws securing the top and bottom covers to the chassis and heat sink. Remove the covers.
- (3) From the rear of the panel, remove the two screws securing the TUNE-O-MATIC pushbutton assembly to the back of the panel. Gently pull assembly away from panel.
- (4) Gently pull the SELECTOR, BASS, TREBLE, BALANCE, VOLUME, and TUNING knobs from the control shafts. Remove the hex nuts from the shafts and remove panel.
- (5) Reverse procedure for reassembly.

REMOVING DIAL GLASS ASSEMBLY

- (1) Remove dress panel. Refer to REMOVING DRESS PANEL procedure.
- (2) Gently pull the four leads from the terminal pins on the top rear of the meter and label each lead with its associated pin location for easy replacement.
- (3) Gently pull the two pairs of dial lamp leads from the terminal pins on the chassis and label each lead.
- (4) Gently pull the pair of meter leads from the terminal pins on the chassis and label.
- (5) Remove the screws holding the dial glass panel. Remove the panel with the dial glass, pilot lamps, and meter attached by tilting out the bottom of the panel and sliding downward. Be careful to avoid deforming dial pointer.
- (6) Reverse procedure for reassembly.

REMOVING P.C. BOARDS

To remove a board from its nylon mounts, squeeze the loop of each mounting clip (using pliers), and lift each corner of the board. To remount the board, align the mounting holes over the clips, and press firmly.

To remove any of the three boards containing the front panel controls and switches, use the following procedure:

- (1) Remove dress panel. Refer to REMOVING DRESS PANEL procedure.
- (2) a. Remove CONTROL AMPLIFIER board by removing hex nuts from BASS, TREBLE, and BALANCE controls.
b. Remove each pushbutton mounting board by removing the appropriate pushbutton knobs and the two screws and nuts holding the switch to the chassis.

REPLACING DIAL LAMPS

- (1) Remove dress panel. Refer to REMOVING DRESS PANEL procedure.
- (2) Snap out the defective lamp from the spring clip. Place the new lamp into the socket so that the unpainted side of the lamp faces the edge of the dial glass.
- (3) Replace the dress panel and knobs.

REPLACING STEREO BEACON AND METER LAMPS

NOTE: The compartmented lamp assembly (FR No. M21C604-2), mounted on the rear of the meter, contains the meter lamp and the STEREO BEACON lamp, and must be replaced as a complete unit.

- (1) Unplug AC power cord.
- (2) Remove the screws securing the top cover to the chassis and heat sink. Remove the cover.
- (3) Gently pull the four wires off the terminal pins on the top rear of the meter. Label each wire with its associated pin location to make replacement easier.
- (4) Gently unsnap the compartmented lamp assembly from the top rear of the meter.
- (5) Center the replacement lamp assembly between the flanges and press firmly on to meter.
- (6) Reconnect the four wires to their associated terminal pins on the replacement lamp assembly.
- (7) Replace the top cover.

REPLACING METER

- (1) Remove dress panel. Refer to REMOVING DRESS PANEL procedure.
- (2) Remove dial glass assembly. Refer to REMOVING DIAL GLASS ASSEMBLY procedure.
- (3) Gently pry the meter off the dial glass panel, and scrape off the residual adhesive.
- (4) Peel the backing from one side of the replacement adhesive mounting pad (FR No. E51A219), and affix it to the replacement meter (FR No. M21C604-1). Peel the backing from the remaining side of the pad, align the meter face over the panel cutout, and firmly press meter to back of panel.
- (5) Remount dial glass assembly.
- (6) Reinstall dress panel. Reconnect all leads to their respective terminal pins.
- (7) Check meter calibration. Refer to FM ALIGNMENT procedure.
- (8) Install top and bottom covers.

DIAL STRINGING

- (1) Remove screws securing top and bottom covers to chassis and heat sink. Remove covers. Remove pointer.
- (2) Rotate tuning capacitor fully CCW. Loosen screw in center of drum and remove old dial cord.
- (3) Tie end of new cord to end of dial spring. Fasten spring to bottom right ear inside drum. See illustration.
- (4) Run cord through rim slot into underside of groove 3.
- (5) Pull cord taut and wrap 2 turns CCW around tuning shaft. See detail.
- (6) Guide cord under and around pulley "A", and around pulleys "B" and "C". Keep cord taut.
- (7) Rotate drum fully CW, allowing cord to wind onto drum.
- (8) Guide cord under drum into groove 5, through rim slot, and under washer.
- (9) Pull cord taut, and tighten screw.
- (10) Rotate drum CCW and CW to distribute tensioning.
- (11) Repeat steps (9) and (10) until spring is tensioned.
- (12) Place cord over and under tabs on pointer (see detail), and place pointer on top of rail.
- (13) Turn tuning shaft fully CCW. Slide pointer to (0) while holding tuning shaft fully CCW. Cement pointer to cord to prevent slippage. Allow cement to thoroughly dry.
- (14) Check dial calibration. Refer to FM/AM ALIGNMENT.

HARMONIC DISTORTION TEST

CAUTION:

- (A) Measure the power of one channel at a time.
- (B) Limit measurements to 10 minutes.
- (C) Use a load resistor with a minimum rating of 50 watts.

Set BASS and TREBLE controls to flat, and SELECTOR switch to AUX. Depress MAIN SPKRS switch. Unplug AC power cord.

- (1) Connect a low-distortion sine-wave generator to the LEFT AUX IN jack. Set generator frequency to 1,000 Hz, and output level to minimum.
- (2) Connect an 8-ohm load resistor between the LEFT SPKRS MAIN and COMMON terminals. In parallel with the load resistor, connect the input leads of an HD analyzer and the input leads of an accurately calibrated AC VTVM.
- (3) Connect AC power cord and rotate VOLUME control to maximum.
- (4) Increase generator level for 32 watts output (15.9V RMS across 8-ohm load). HD meter should read 0.5% or less.
- (5) Repeat preceding steps for right channel.

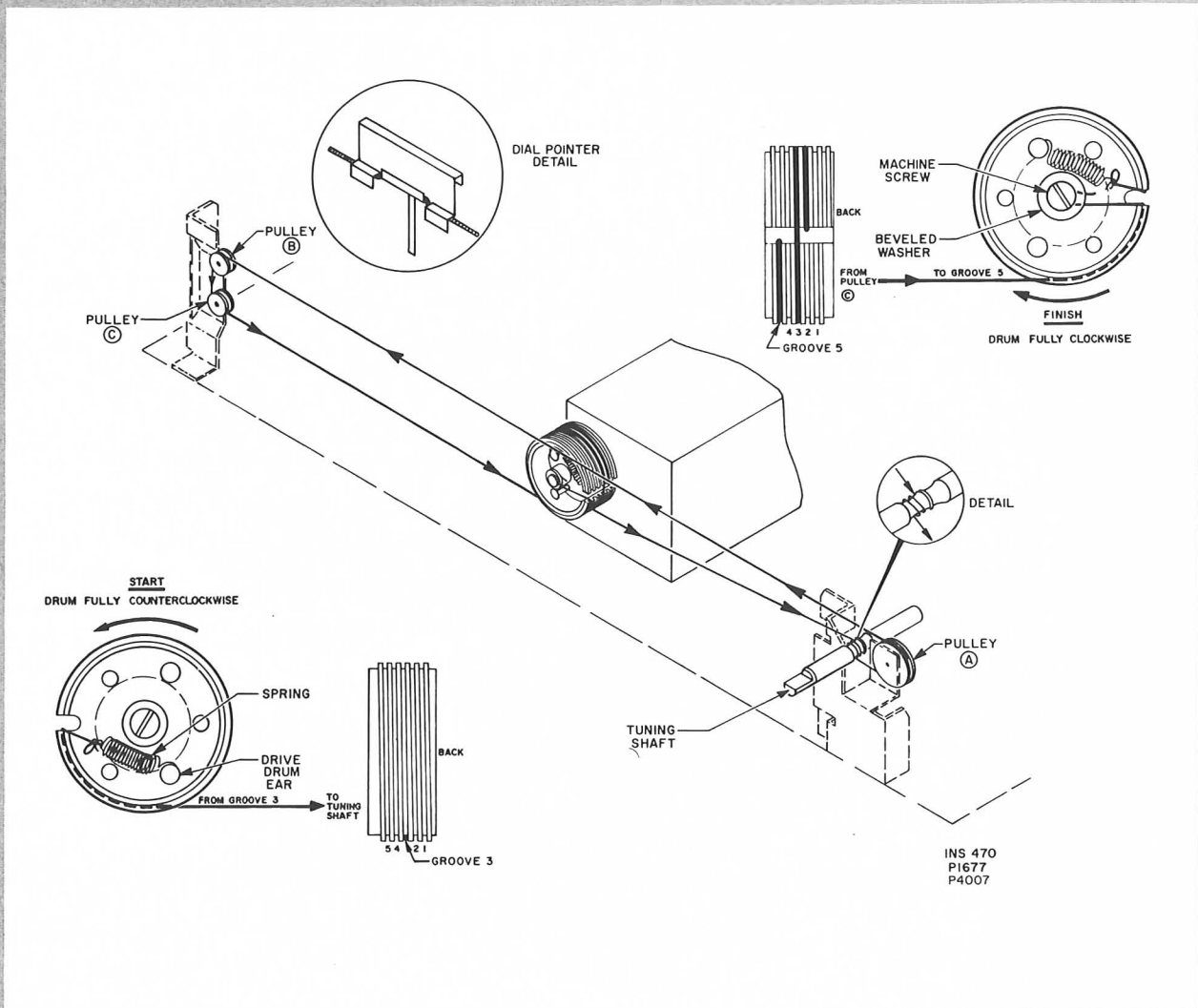

CHASSIS LAYOUT

TOP VIEW

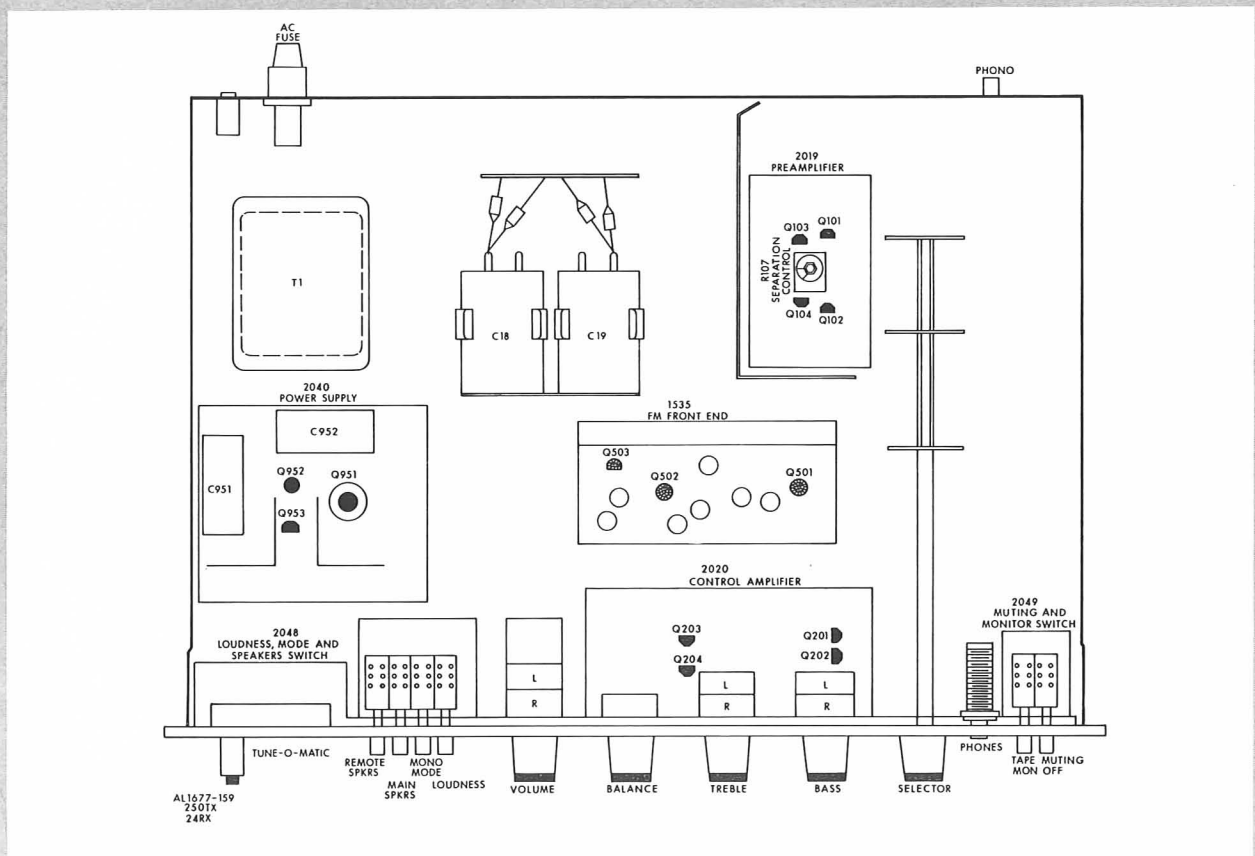
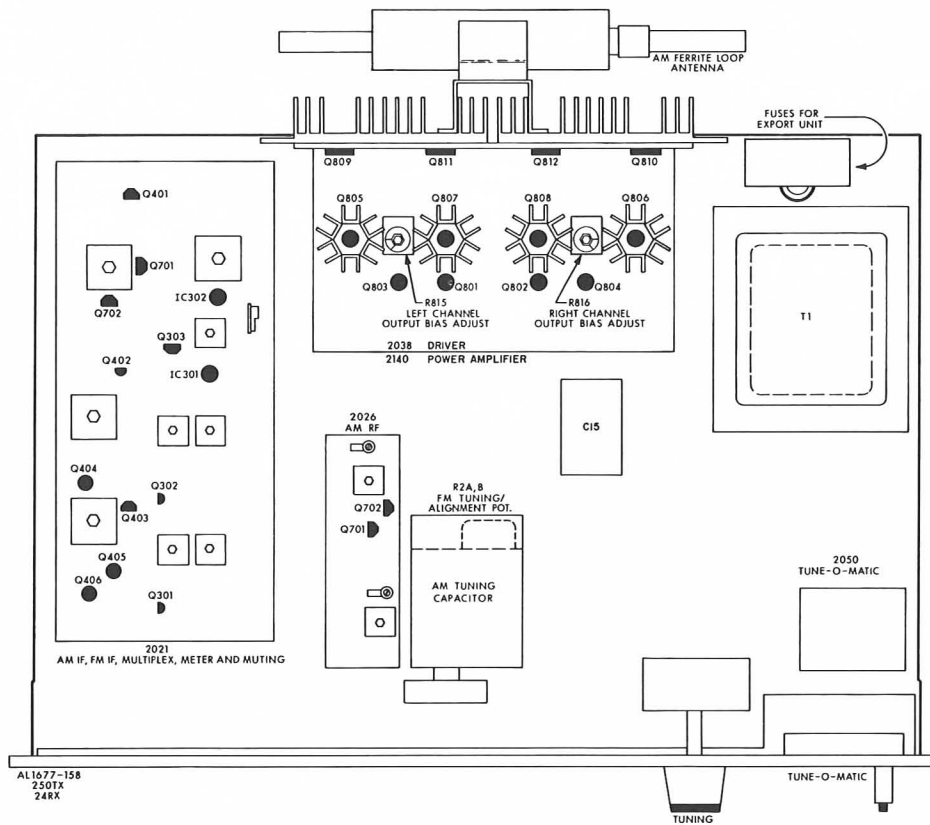

BOTTOM VIEW

2040-1 POWER SUPPLY

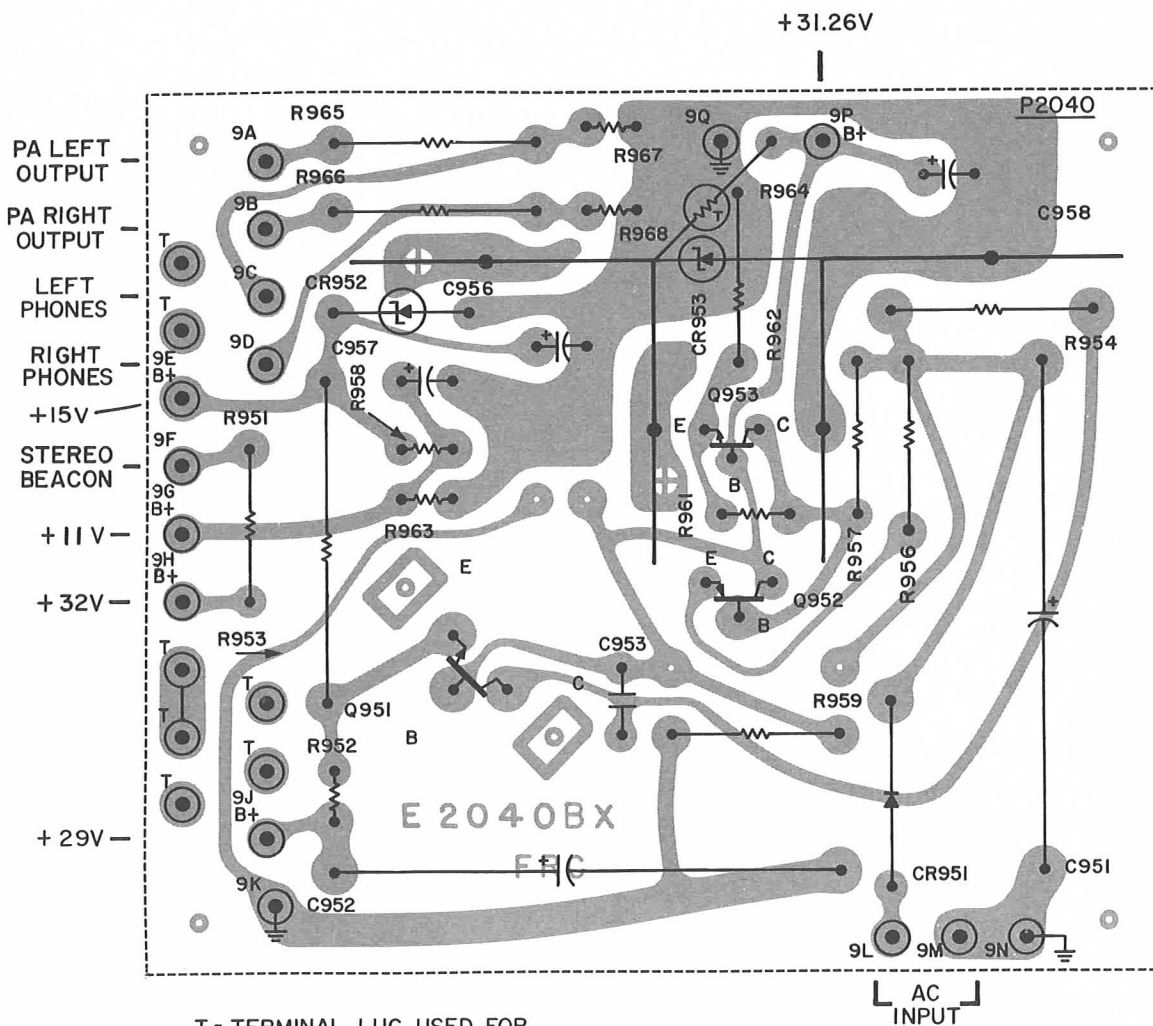

T = TERMINAL LUG USED FOR EASE IN WIRING.

P2040-1
IL2040B112A

MAIN CHASSIS

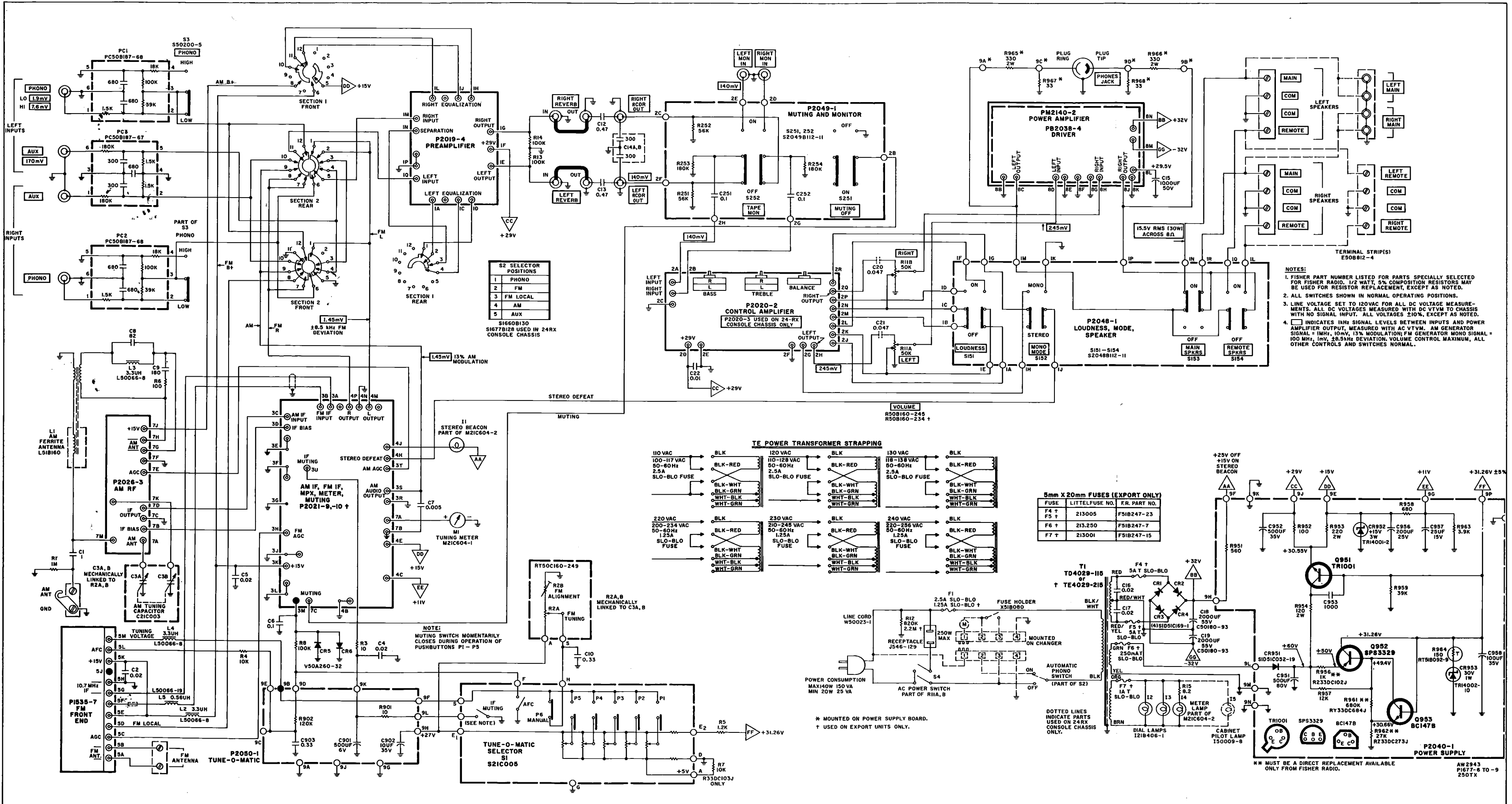

S2 SELECTOR POSITIONS

1	PHONO
2	FM
3	FM LOCAL
4	AM
5	AUX

S1660B130
S1677B128 USED IN 24RX CONSOLE CHASSIS

TE POWER TRANSFORMER STRAPPING

110 VAC 100-117 VAC 50-60Hz 2.5A SLO-BLO FUSE	120 VAC 110-128 VAC 50-60Hz 2.5A SLO-BLO FUSE	130 VAC 118-138 VAC 50-60Hz 2.5A SLO-BLO FUSE
220 VAC 200-234 VAC 50-60Hz 1.25A SLO-BLO FUSE	230 VAC 210-245 VAC 50-60Hz 1.25A SLO-BLO FUSE	240 VAC 220-256 VAC 50-60Hz 1.25A SLO-BLO FUSE

5mm x 20mm FUSES (EXPORT ONLY)

FUSE	LITTELFUSE NO.	FR. PART NO.
F4 †	213005	F51B247-23
F5 †	213005	F51B247-23
F6 †	213.250	F51B247-7
F7 †	213001	F51B247-15

- NOTES:
- FISHER PART NUMBER LISTED FOR PARTS SPECIALLY SELECTED FOR FISHER RADIO. 1/2 WATT, 5% COMPOSITION RESISTORS MAY BE USED FOR RESISTOR REPLACEMENT, EXCEPT AS NOTED.
 - ALL SWITCHES SHOWN IN NORMAL OPERATING POSITIONS.
 - LINE VOLTAGE SET TO 120VAC FOR ALL DC VOLTAGE MEASUREMENTS. ALL DC VOLTAGES MEASURED WITH DC VTVM TO CHASSIS WITH NO SIGNAL INPUT. ALL VOLTAGES ±10%, EXCEPT AS NOTED.
 - INDICATES 1kHz SIGNAL LEVELS BETWEEN INPUTS AND POWER AMPLIFIER OUTPUT, MEASURED WITH AC VTVM. AM GENERATOR SIGNAL = 1MHz, 10mV, 15% MODULATION; FM GENERATOR MONO SIGNAL = 100 MHz, 1mV, 28.5kHz DEVIATION, VOLUME CONTROL MAXIMUM, ALL OTHER CONTROLS AND SWITCHES NORMAL.

* MOUNTED ON POWER SUPPLY BOARD.
† USED ON EXPORT UNITS ONLY.

** MUST BE A DIRECT REPLACEMENT AVAILABLE ONLY FROM FISHER RADIO.

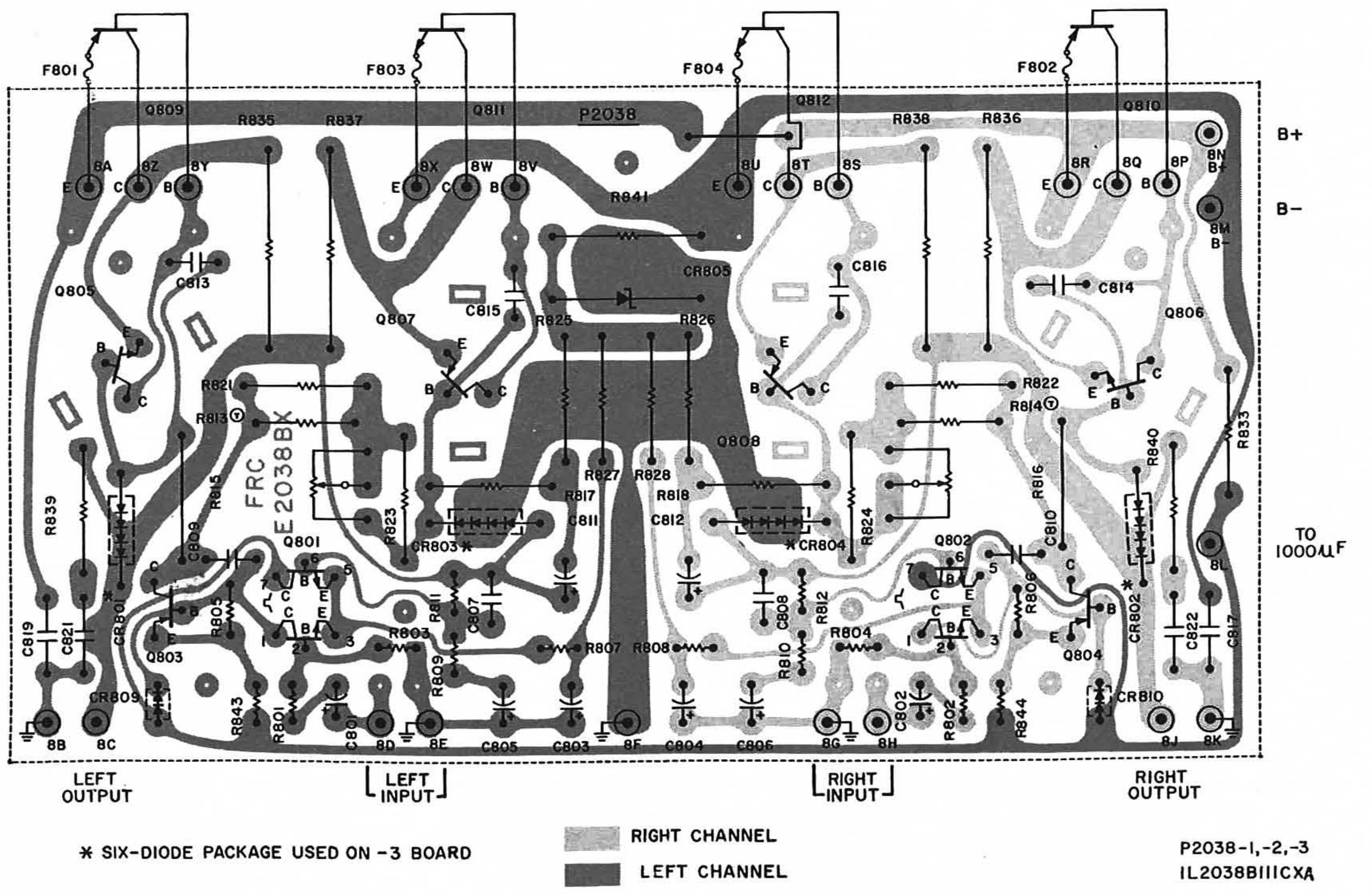
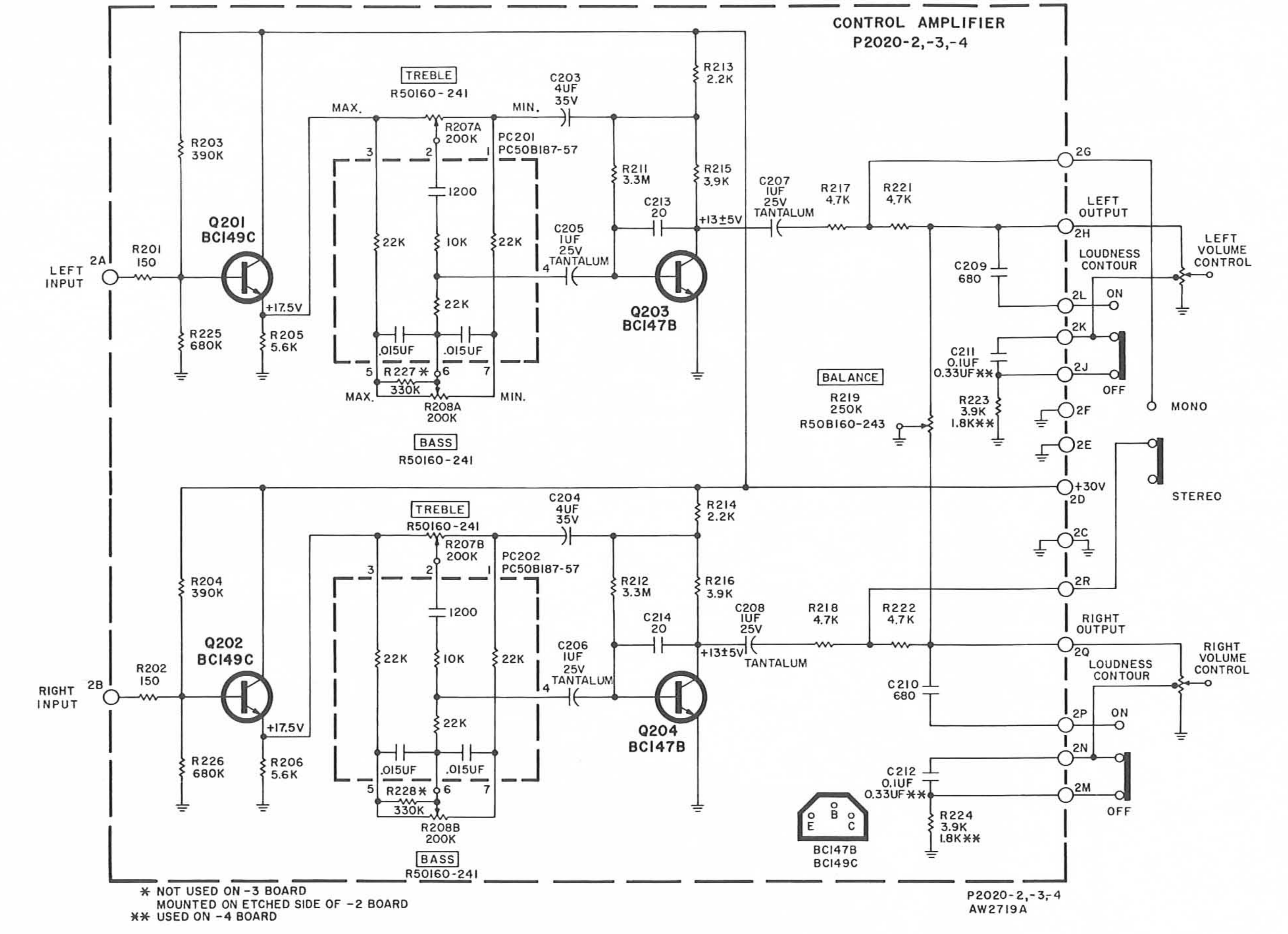
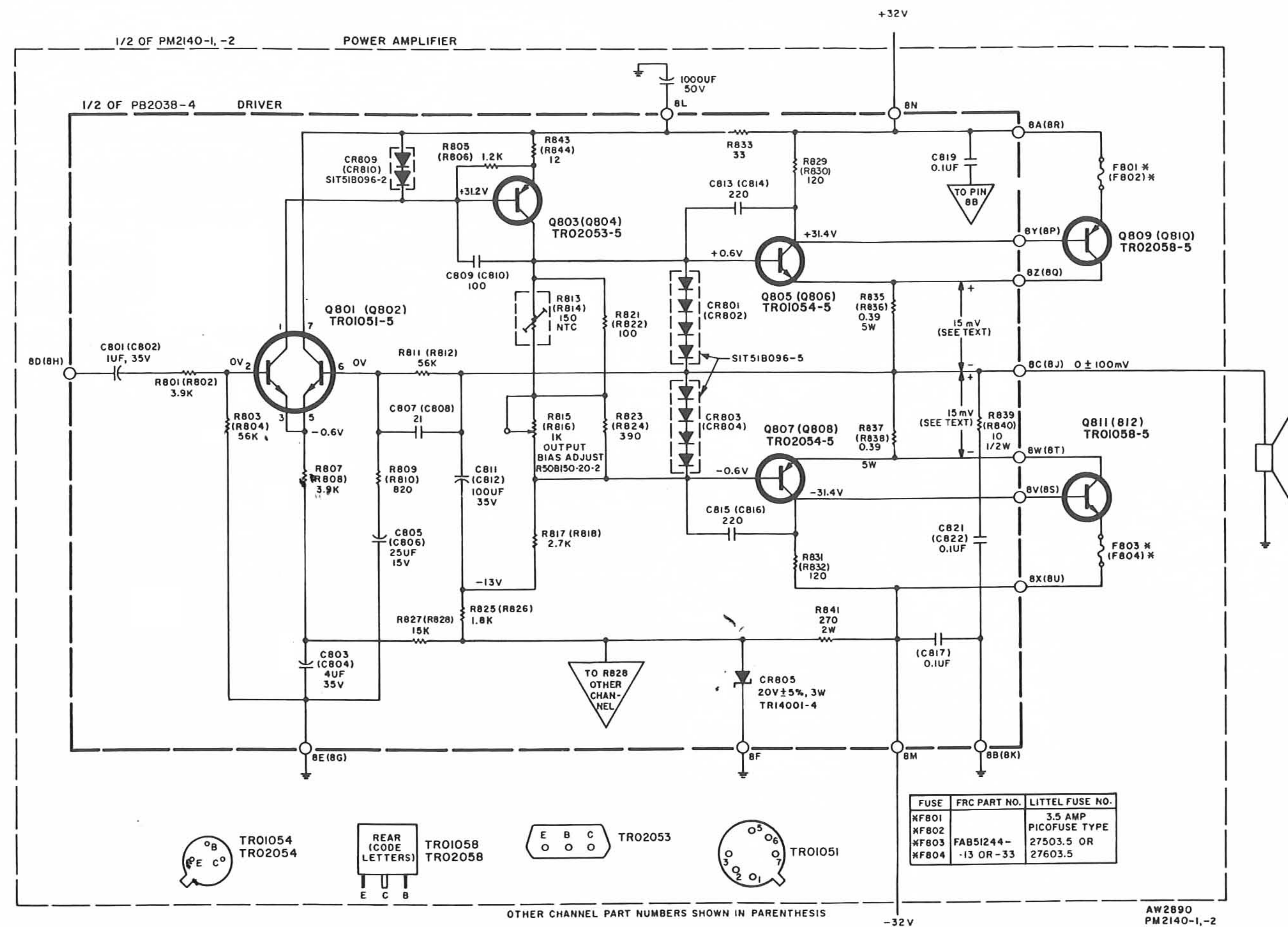

CENTER VOLTAGE TEST

Turn VOLUME control to minimum. Depress MAIN SPKRS switch.
 (1) Connect DC VTVM across LEFT MAIN SPKRS terminals. Meter should read OVDC (+100 mV).
 (2) Connect DC VTVM across RIGHT MAIN SPKRS terminals. Meter should read OVDC (+100 mV).

IDLING CURRENT ADJUSTMENT

Turn VOLUME control to minimum.
 (1) Connect ground lead of DC VTVM to pin 8C and probe to pin 8Z. BE CAREFUL TO AVOID SHORTING ADJACENT PINS. Set BIAS ADJUST pot. R815 for 15 mVDC.
 (2) Connect ground lead of DC VTVM to pin 8J and probe to pin 8Q. BE CAREFUL TO AVOID SHORTING ADJACENT PINS. Set BIAS ADJUST pot. R816 for 15 mVDC.

NOTE: Idling current will increase and stabilize as amplifier temperature normalizes.

(3) Allow unit to warm up 15 minutes. Repeat steps (1) and (2), resetting BIAS ADJUST pots. for 15 mVDC.

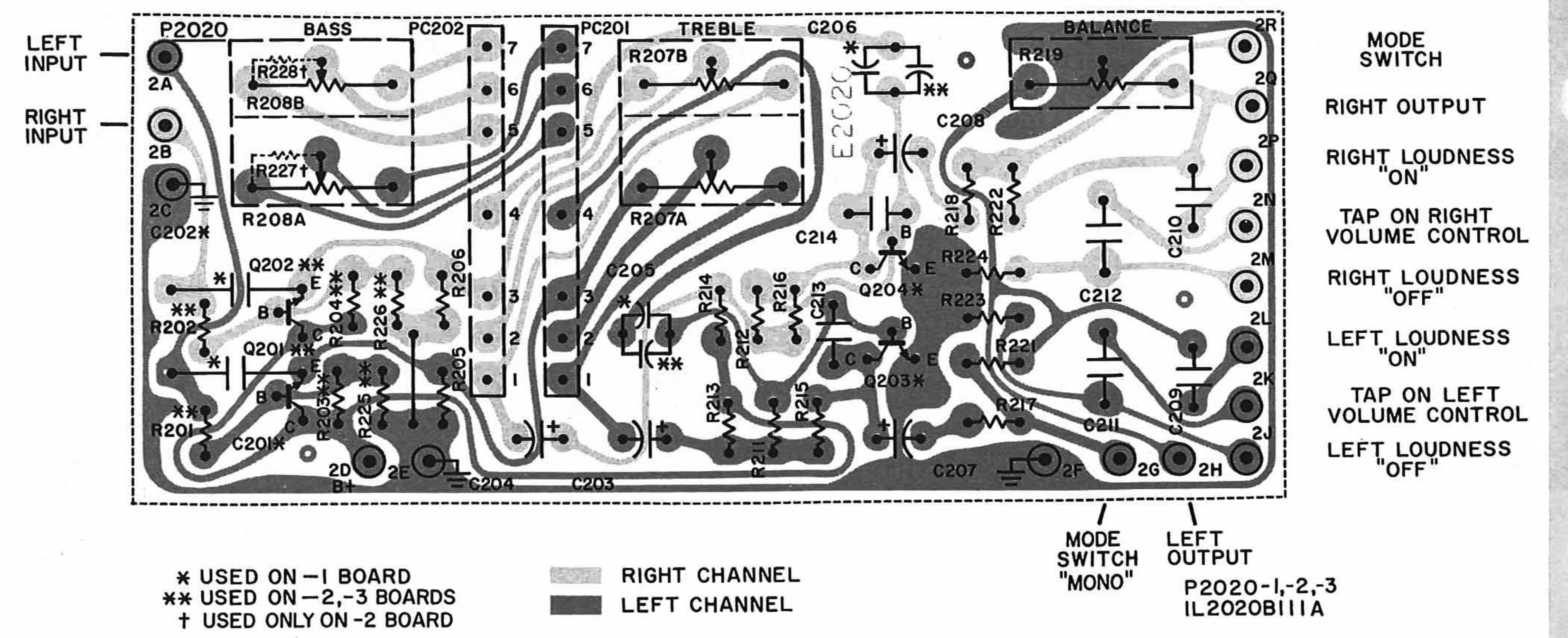

- MODE SWITCH
- RIGHT OUTPUT
- RIGHT LOUDNESS "ON"
- TAP ON RIGHT VOLUME CONTROL
- RIGHT LOUDNESS "OFF"
- LEFT LOUDNESS "ON"
- TAP ON LEFT VOLUME CONTROL
- LEFT LOUDNESS "OFF"

2019-4 PREAMPLIFIER

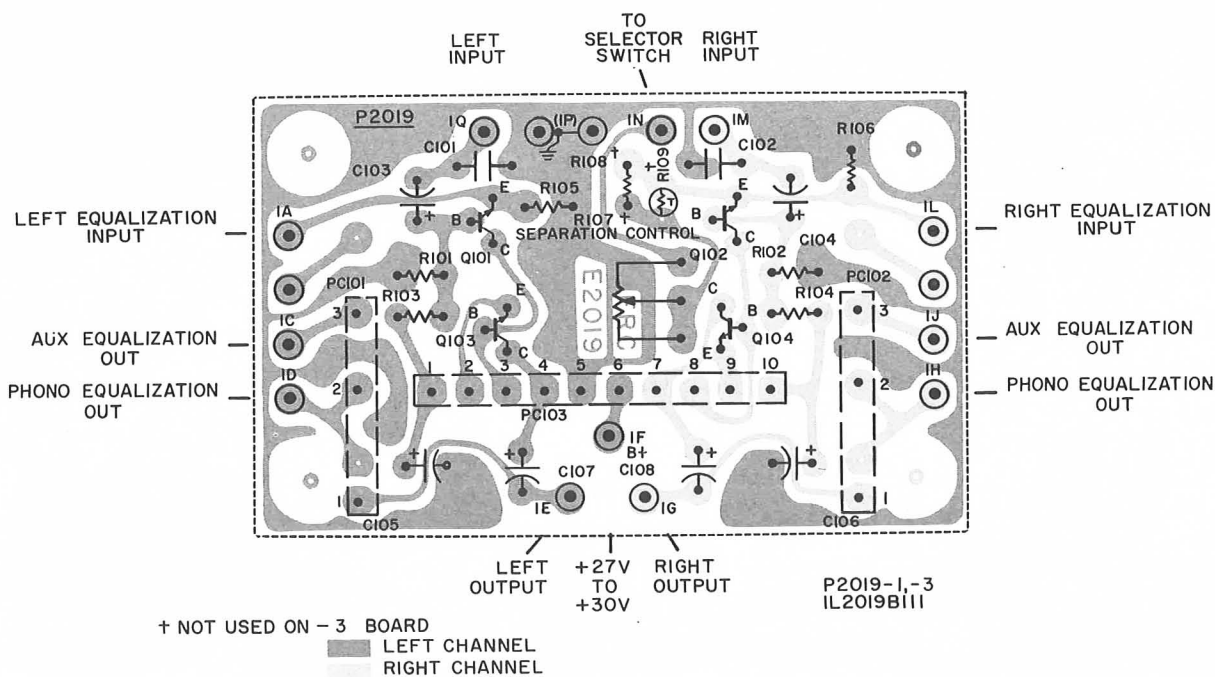
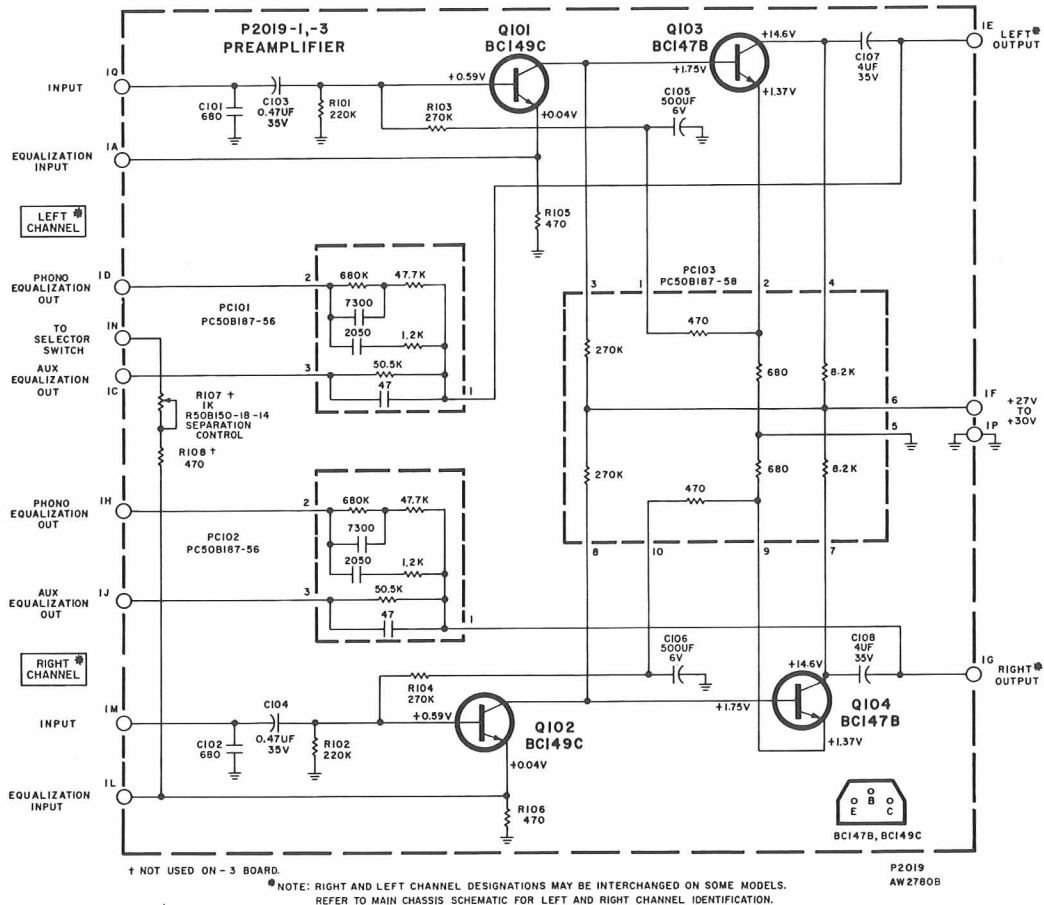

1535-7 FM RF

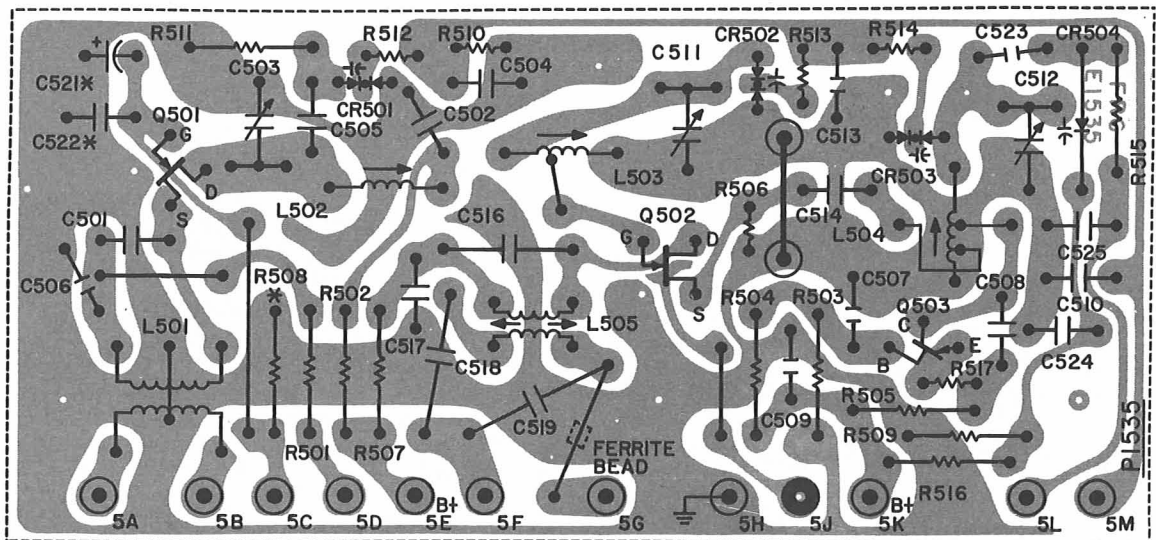
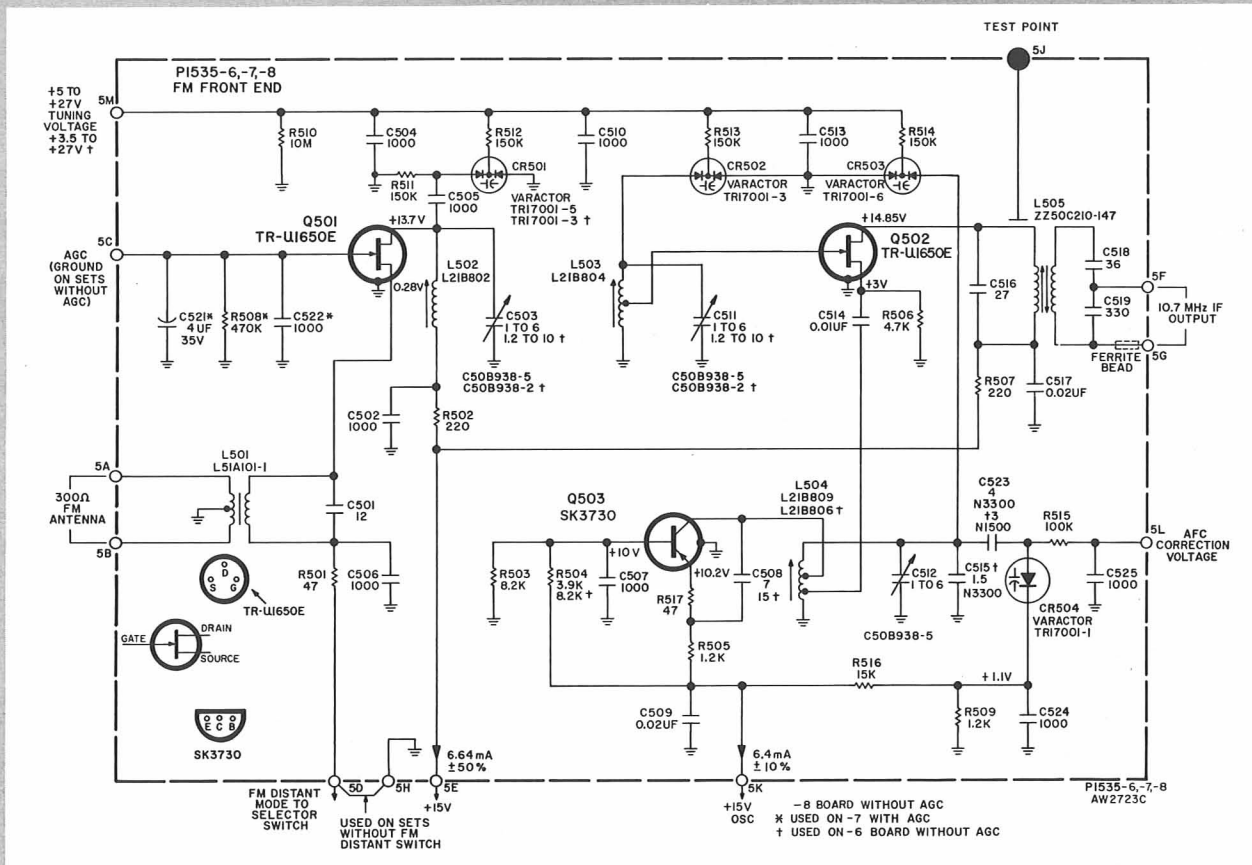

* SEE SCHEMATIC

PI535-1,-2,-6
IL1535B113D

2026-3 AM RF

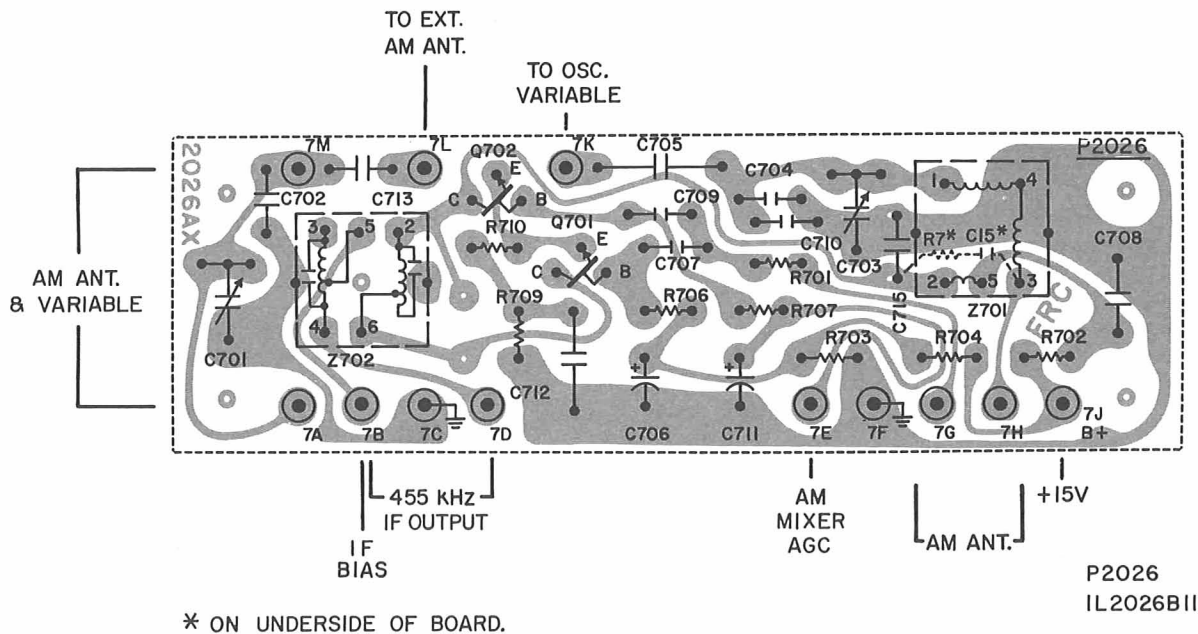
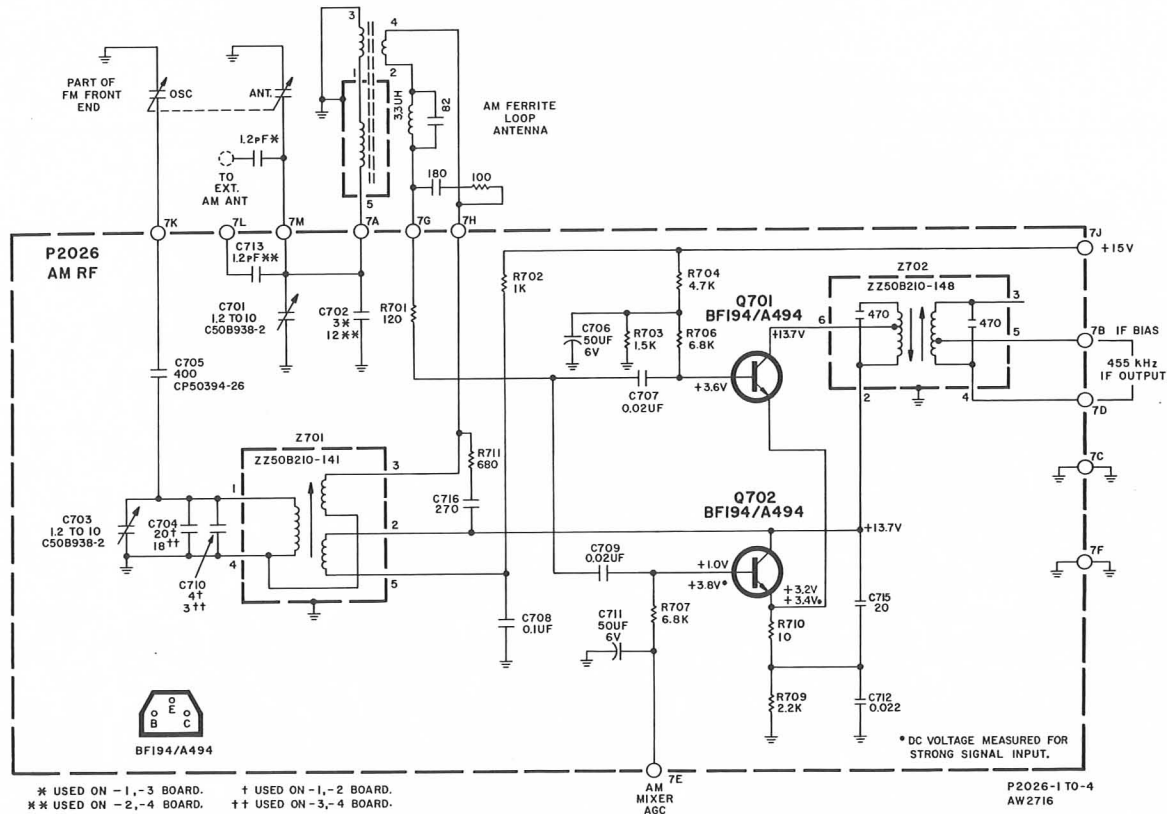

Turn TUNING knob fully CCW. If pointer is not centered on (0), reposition and cement pointer. Except as noted, maintain generator level as low as possible during alignment.

FM ALIGNMENT

(1) Set SELECTOR to FM, and AFC to OFF. Turn VOLUME to minimum. Depress MUTING OFF switch.

(2) Disconnect jumper from pin 3N. Connect AC input of scope to pin 3N, scope ground to pin 3G. Connect an 82k resistor across scope input.

(3) Connect 10.7MHz sweep generator to pin 5J, generator ground to pin 5H.

(4) Adjust top and bottom cores of Z305, Z304, Z302, and L505 for maximum gain and symmetry. See FM IF illustration.

(5) Increase generator level to full output (approximately 100mV). If necessary, slightly readjust top core of Z305 to center 10.7MHz marker (see FM IF-LIMITED illustration).

(6) Reconnect jumper to pin 3N. Disconnect 82k resistor across scope input.

(7) Reduce generator sweep to zero (sweep off). Adjust R328 FM METER ADJ. for front panel tuning meter reading of 4.5.

(8) Connect a 100k resistor in series with AC input of scope and connect to pin 4A, scope ground to pin 3L.

(9) Adjust bottom and top cores of Z306. See FM DETECTOR illustration.

(10) Connect DC VTVM to pin 4A. Use lowest (most sensitive) range. Readjust top core of Z306 for 0 VDC. Disconnect test equipment.

(11) Depress MONO MODE and MANUAL switches. Connect an accurately calibrated DC VTVM to pin 9B (on TUNE-O-MATIC board).

(12) Center dial pointer on 88MHz fiducial mark (1.1 on logging scale). Using a small screwdriver, adjust R2B (on back of AM tuning capacitor) for exactly 4.3 VDC. Disconnect DC VTVM.

(13) Connect an FM signal generator to FM ANTenna terminals through 120-ohm composition resistors, one in series with each lead from the generator. Connect a scope and an AC VTVM to the LEFT RCDR OUT jack.

(14) Set generator frequency and dial pointer accurately to 90MHz (1.85 on logging scale). Modulate generator with 400Hz, ± 75 kHz deviation. Adjust top and bottom core of L504, and top core of L503, and L502 for maximum AC, and maximum on front panel tuning meter.

(15) Set generator frequency and dial pointer accurately to 106MHz (8.45 on logging scale). Adjust C512, C511, and C503 for maximum AC and maximum on front panel tuning meter.

(16) Repeat steps (14) and (15) for accurate dial calibration and maximum audio.

(17) Release MONO MODE switch. Increase generator level to 10mV. Connect MPX generator composite output to FM signal generator EXTERNAL MODULATION input. Modulate generator signal with 19kHz, ± 7.5 kHz deviation (10% pilot, no audio).

(18) Connect DC VTVM to pin 4G. Tune receiver accurately to generator frequency. Adjust Z401, and Z402 for maximum DC (2.5 to 4 VDC).

(19) Modulate generator with MPX composite signal, ± 75 kHz deviation (90% 1kHz audio, 10% 19kHz pilot). Modulate right channel only.

(20) Connect an AC VTVM to LEFT RCDR OUT jack. Connect another AC VTVM to RIGHT RCDR OUT jack. Connect scope input through voltage divider to pin 4K.

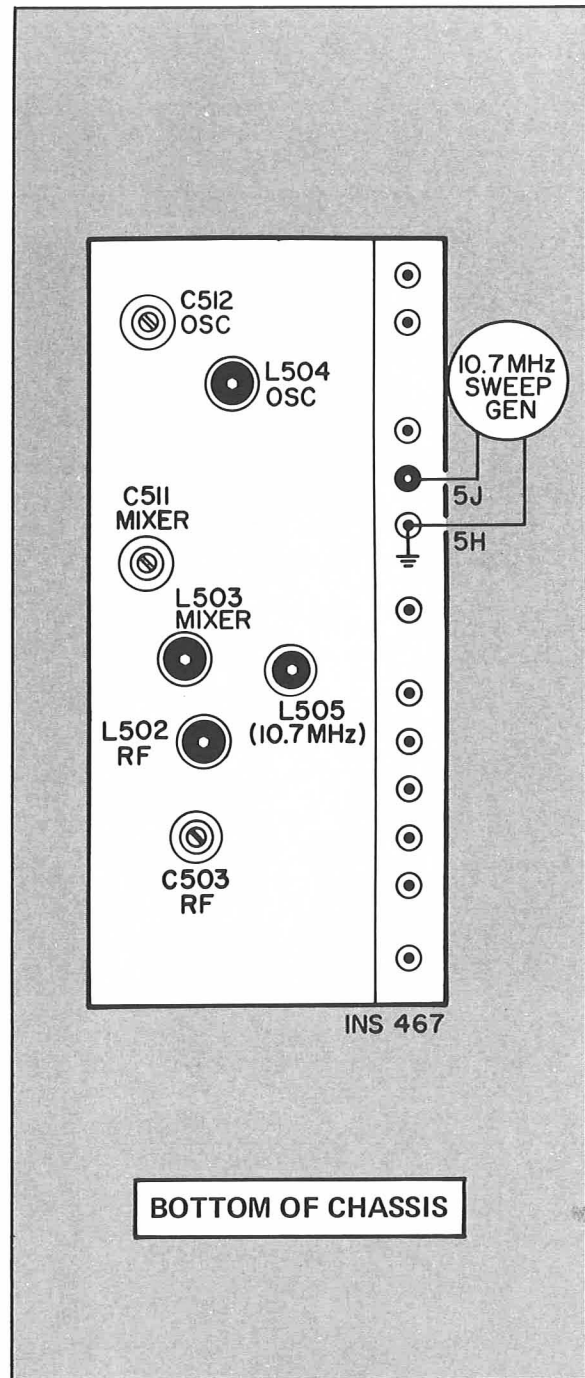

(21) Using an ohmmeter, temporarily set R107 SEPARATION CONTROL (on preamplifier board) to maximum resistance. Adjust Z403 for maximum scope amplitude and as straight a base-line as possible (see MPX OUTPUT illustration). Left channel AC should be minimum.

(22) Modulate left channel only. Adjust R107 SEPARATION CONTROL for minimum AC on right channel (at least 30dB below left channel).

(23) Modulate right channel only. Left channel should be at least 30dB below right channel.

NOTE: If separation measurements are not within 3dB of each other, readjust Z402 slightly, and repeat steps (21) through (23).

TUNER ALIGNMENT

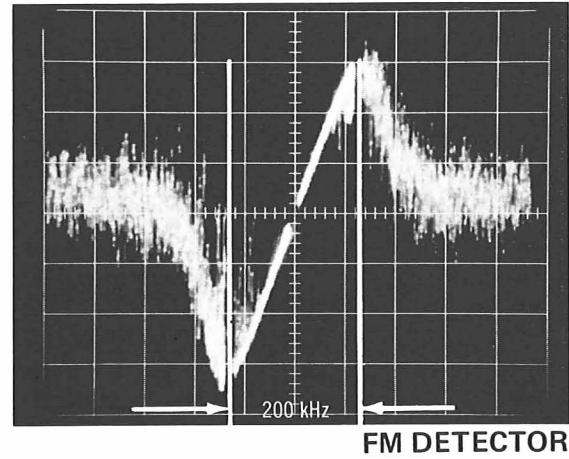
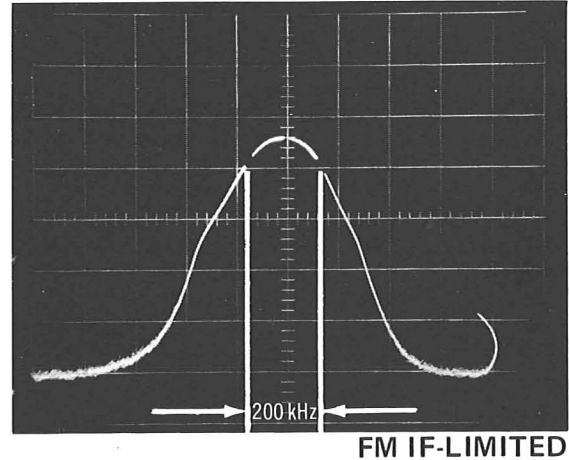
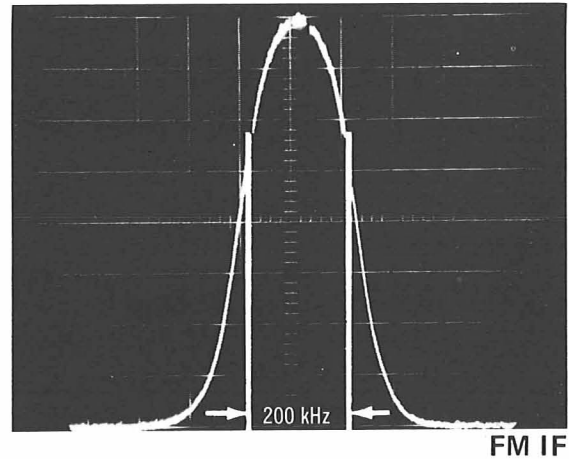
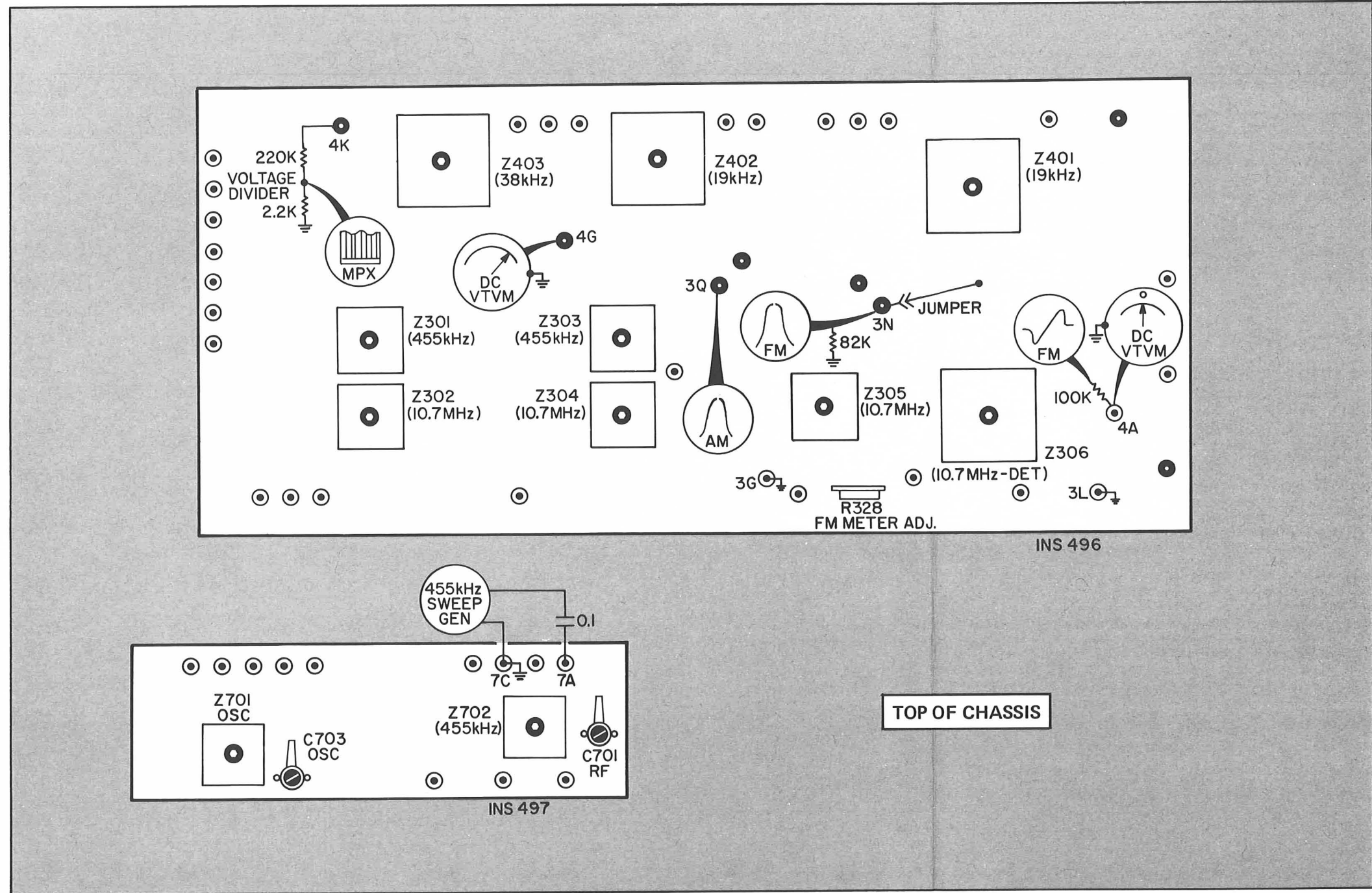

TOP OF CHASSIS

AM ALIGNMENT

- (1) Set SELECTOR to AM, VOLUME to minimum.
- (2) Connect 455kHz sweep generator to pin 7A, generator ground to pin 7C. Use a 0.1uF capacitor in series with generator lead.
- (3) Connect scope input to pin 3Q, scope ground to pin 3G.
- (4) Adjust top and bottom cores of Z303, Z301, and Z702 for maximum gain and symmetry. See AM IF illustration. Disconnect test equipment.
- (5) Open AM ANTenna GND link. Connect an AM signal generator to the AM ANT and GND terminals. Connect a scope and an AC VTVM to LEFT RCDR OUT jack.

- (6) Set generator frequency and dial pointer to 600kHz (2.1 on logging scale). Modulate generator with 400Hz, 30% modulation. Adjust Z701 for maximum audio.
- (7) Set generator frequency and dial pointer to 1400kHz (8.47 on logging scale). Adjust C703 for maximum audio.
- (8) Repeat steps (6) and (7) for accurate dial calibration and maximum gain.
- (9) Reset generator and pointer to 600kHz. Melt the wax holding the coil to the ferrite antenna. Shift the coil for maximum audio. Remelt wax to secure coil in position.
- (10) Reset generator and pointer to 1400kHz. Adjust C701 for maximum audio.
- (11) Repeat steps (9) and (10) for maximum gain.

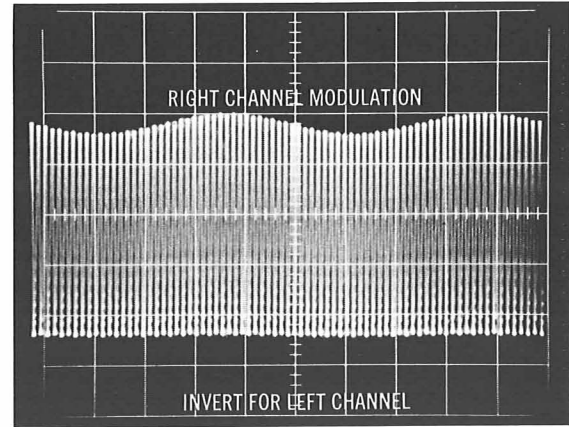
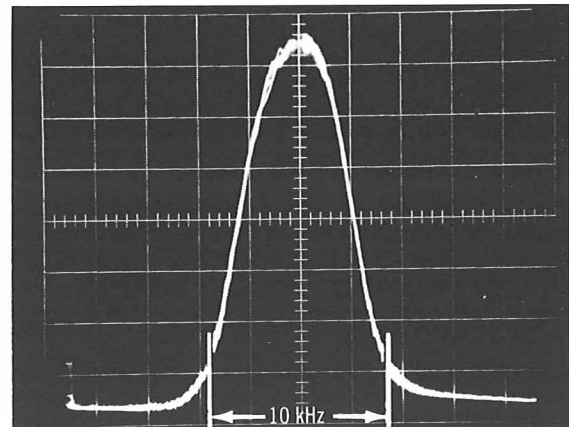

AM IF

MPX OUTPUT

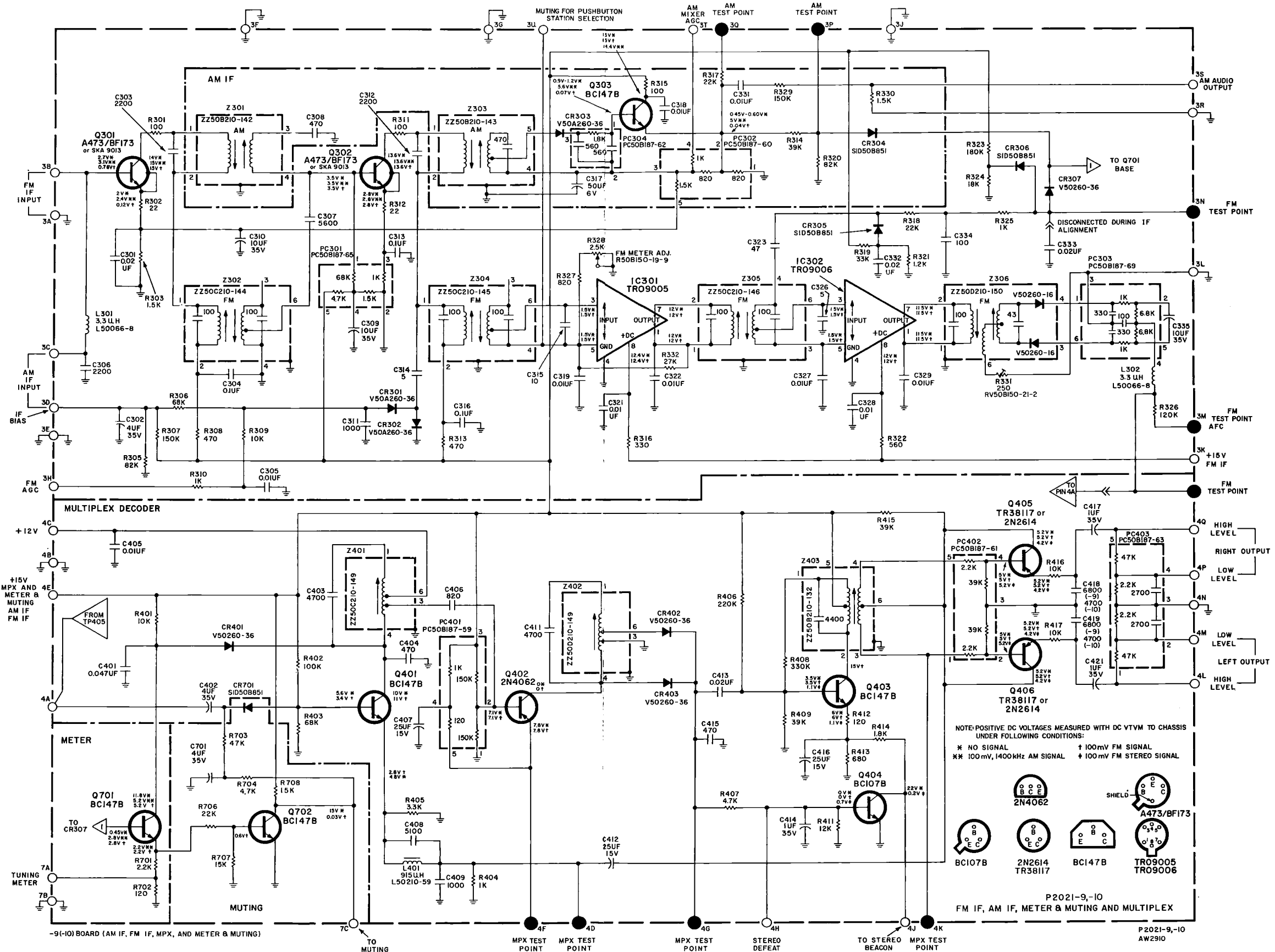

NOTE: POSITIVE DC VOLTAGES MEASURED WITH DC VTVM TO CHASSIS UNDER FOLLOWING CONDITIONS:
 * NO SIGNAL † 100mV FM SIGNAL
 ** 100mV, 1400kHz AM SIGNAL ‡ 100mV FM STEREO SIGNAL

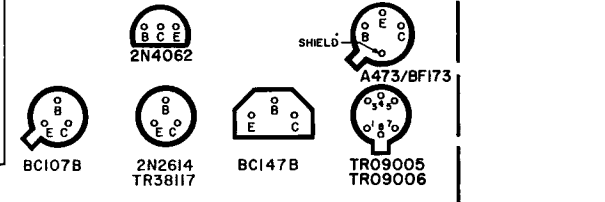

P2021-9-10
 FM IF, AM IF, METER & MUTING AND MULTIPLEX

-9(-10) BOARD (AM IF, FM IF, MPX, AND METER & MUTING) TO MUTING SWITCH MPX TEST POINT MPX TEST POINT MPX TEST POINT STEREO DEFEAT TO STEREO BEACON MPX TEST POINT

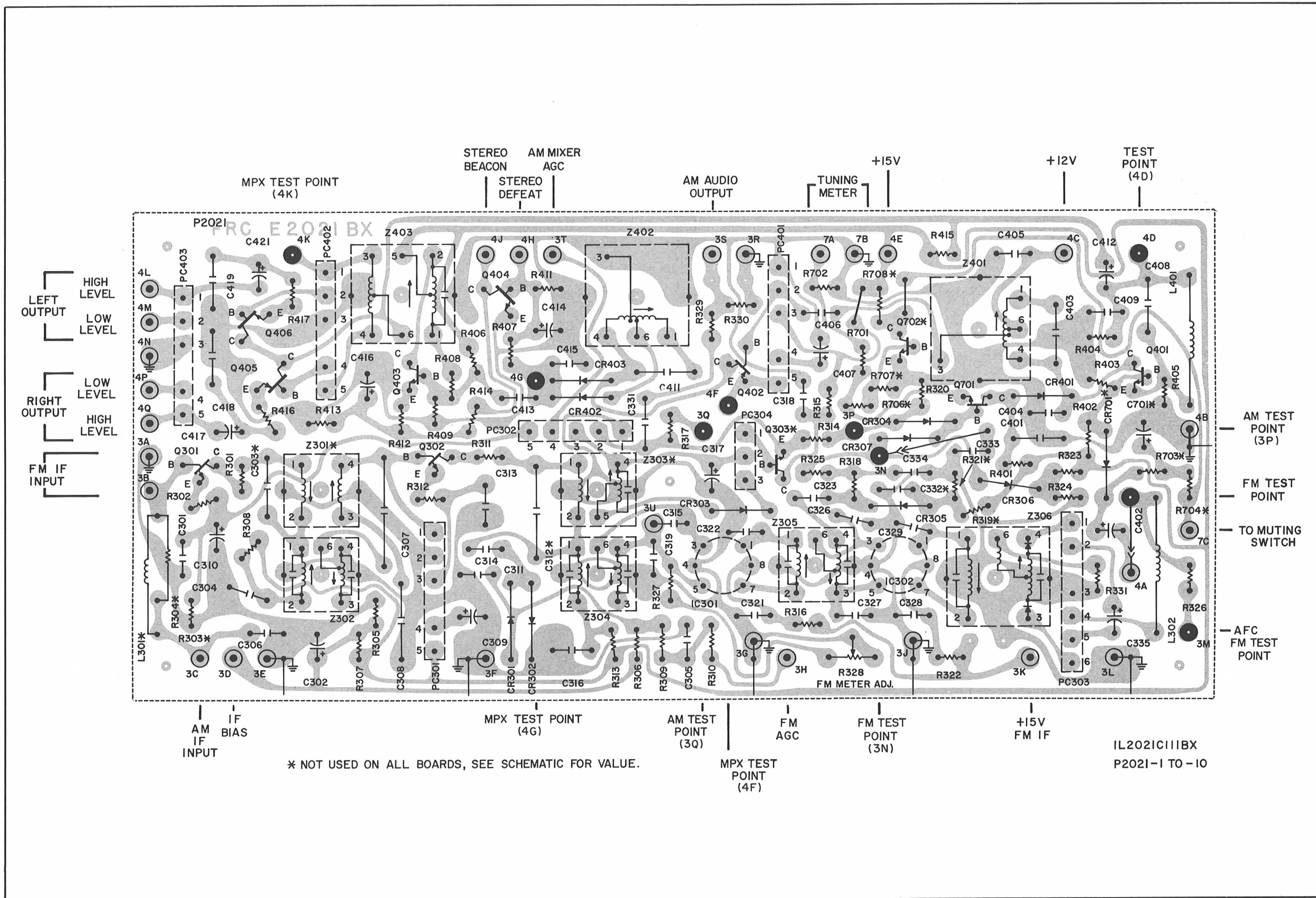

LEFT OUTPUT
HIGH LEVEL
LOW LEVEL

RIGHT OUTPUT
LOW LEVEL
HIGH LEVEL

FM IF INPUT

* NOT USED ON ALL BOARDS, SEE SCHEMATIC FOR VALUE.

IL2021C111BX
P2021-1 TO -10

PUSHBUTTON-SWITCH BOARDS

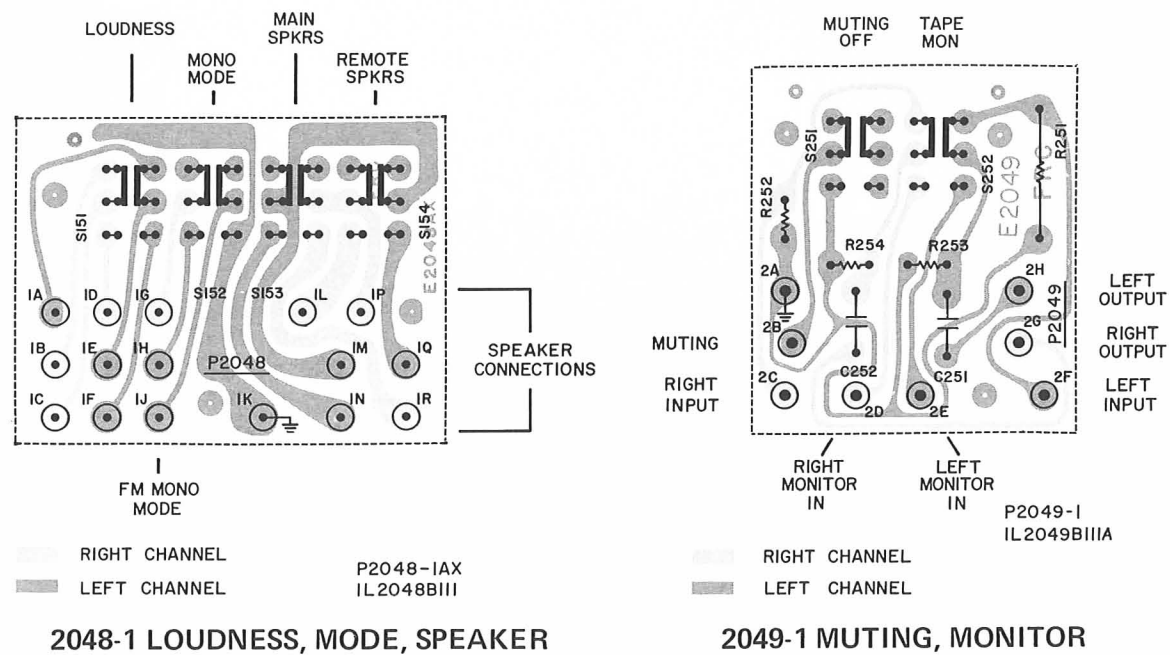

SCHEMATICS SHOWN ON MAIN CHASSIS DIAGRAM

2050-1 TUNE-O-MATIC

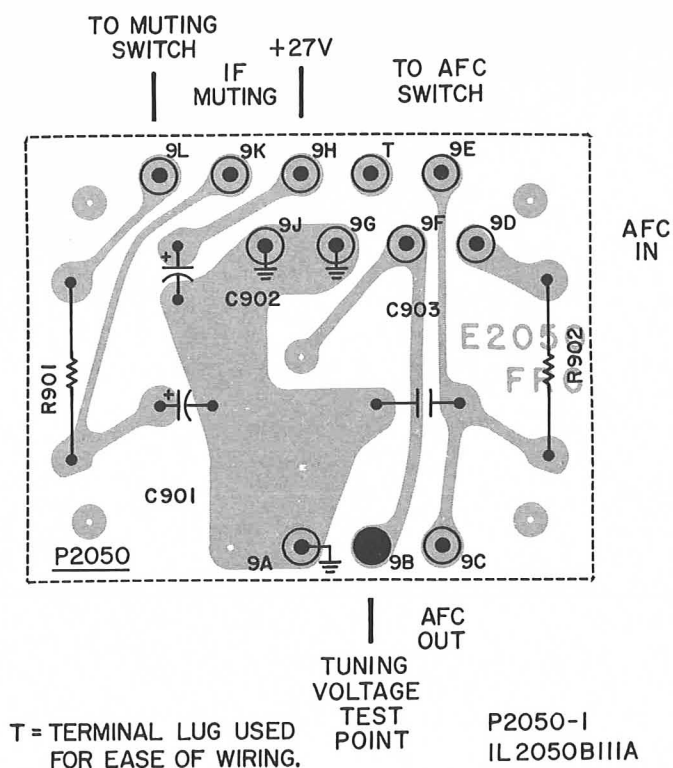

SCHEMATIC SHOWN ON MAIN CHASSIS DIAGRAM

COMPONENT CONNECTIONS

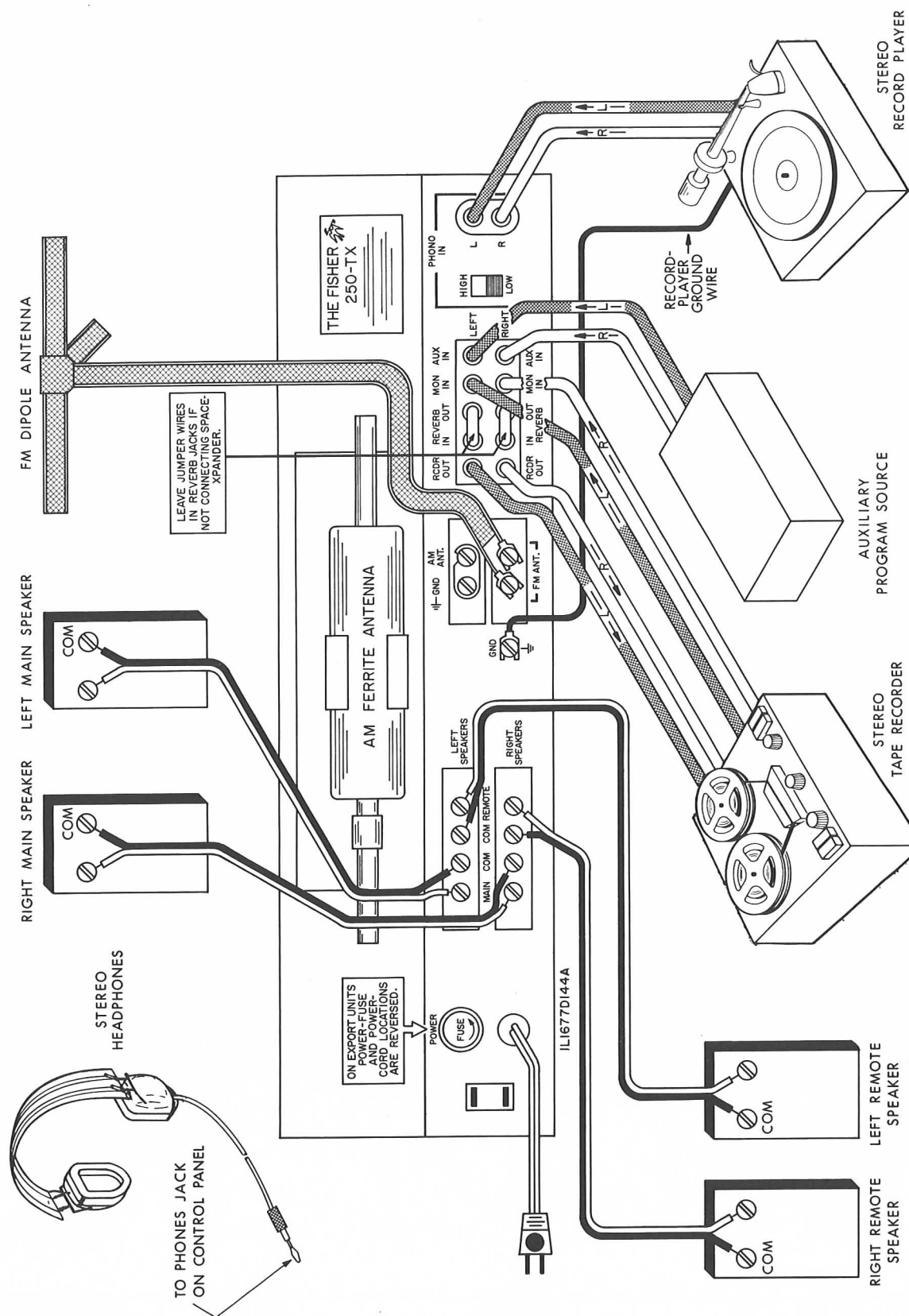

FISHER RADIO • LONG ISLAND CITY • NEW YORK 11101

