

The enclosed schematics cover THE FISHER 304 Receiver, and will provide servicing information until complete service manuals are available.

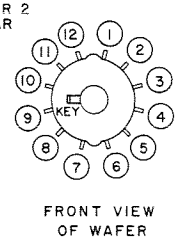

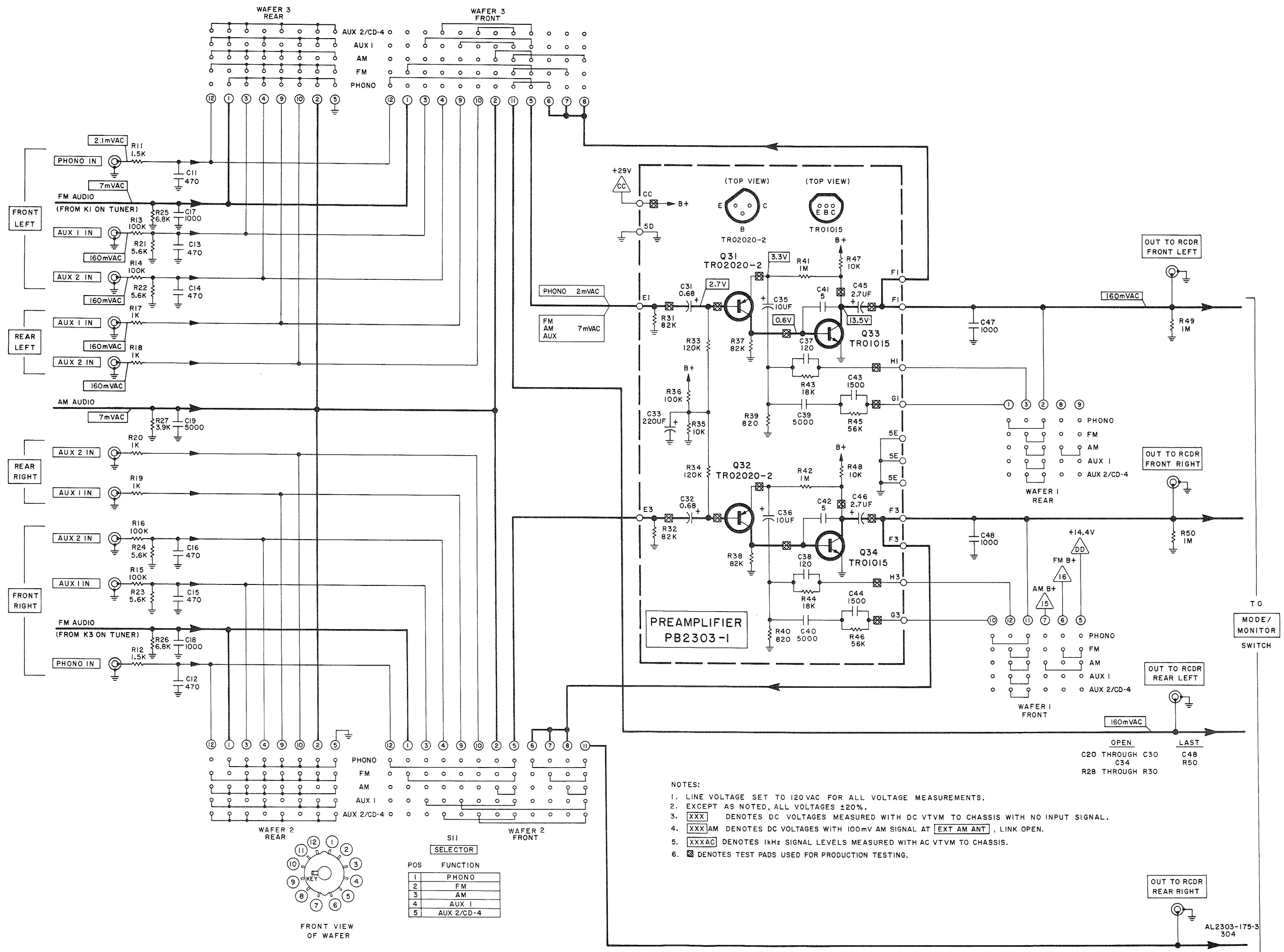

S11 SELECTOR	
POS	FUNCTION
1	PHONO
2	FM
3	AM
4	AUX 1
5	AUX 2/CD-4

- NOTES:
1. LINE VOLTAGE SET TO 120 VAC FOR ALL VOLTAGE MEASUREMENTS.
 2. EXCEPT AS NOTED, ALL VOLTAGES $\pm 20\%$.
 3. [XXX] DENOTES DC VOLTAGES MEASURED WITH DC VTVM TO CHASSIS WITH NO INPUT SIGNAL.
 4. [XXX]AM DENOTES DC VOLTAGES WITH 100mV AM SIGNAL AT [EXT AM ANT], LINK OPEN.
 5. [XXXAC] DENOTES 1kHz SIGNAL LEVELS MEASURED WITH AC VTVM TO CHASSIS.
 6. [X] DENOTES TEST PADS USED FOR PRODUCTION TESTING.

OPEN C20 THROUGH C30
C34
R28 THROUGH R30

LAST C48
R50

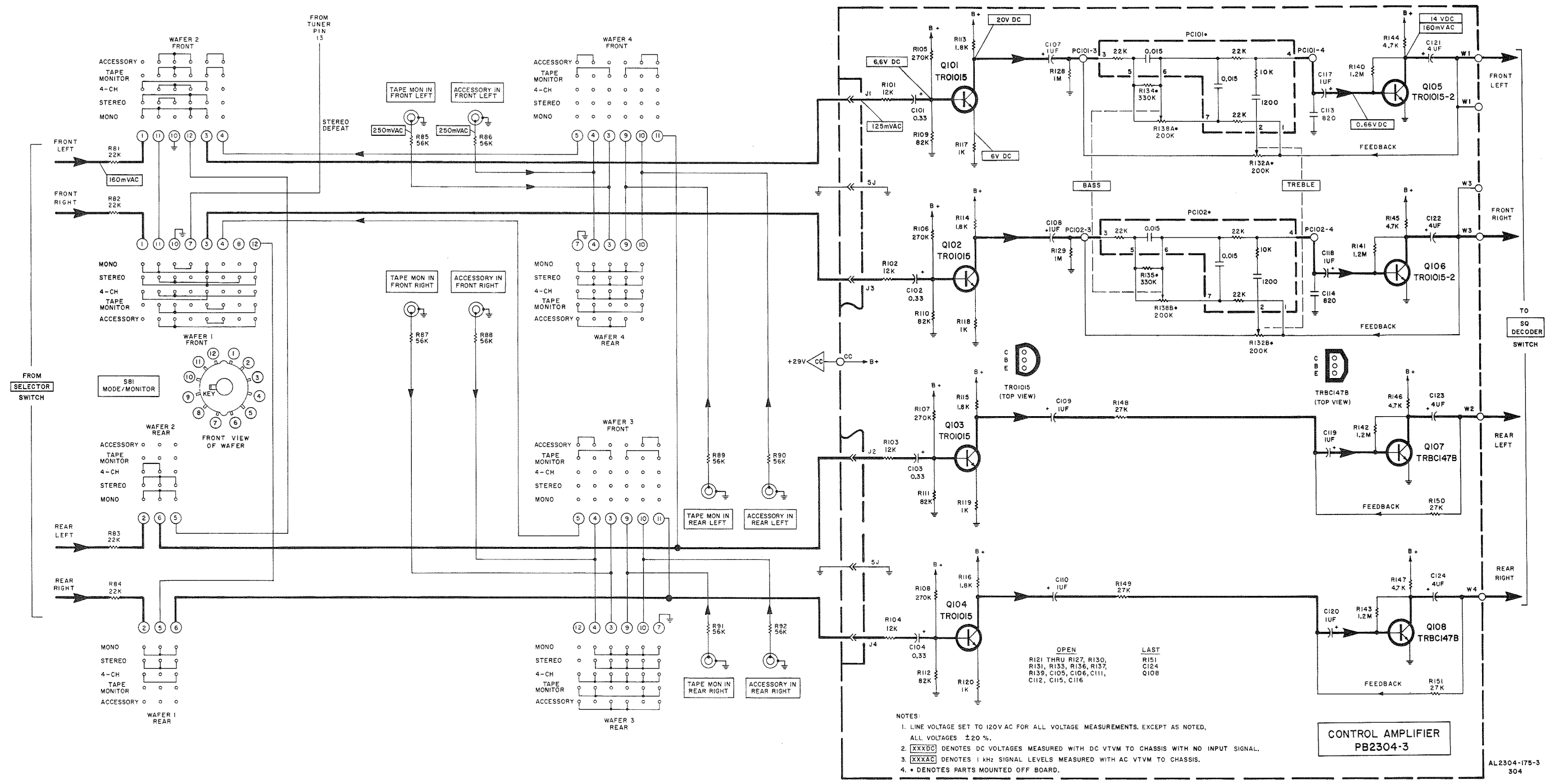

CONTROL AMPLIFIER
PB2304-3

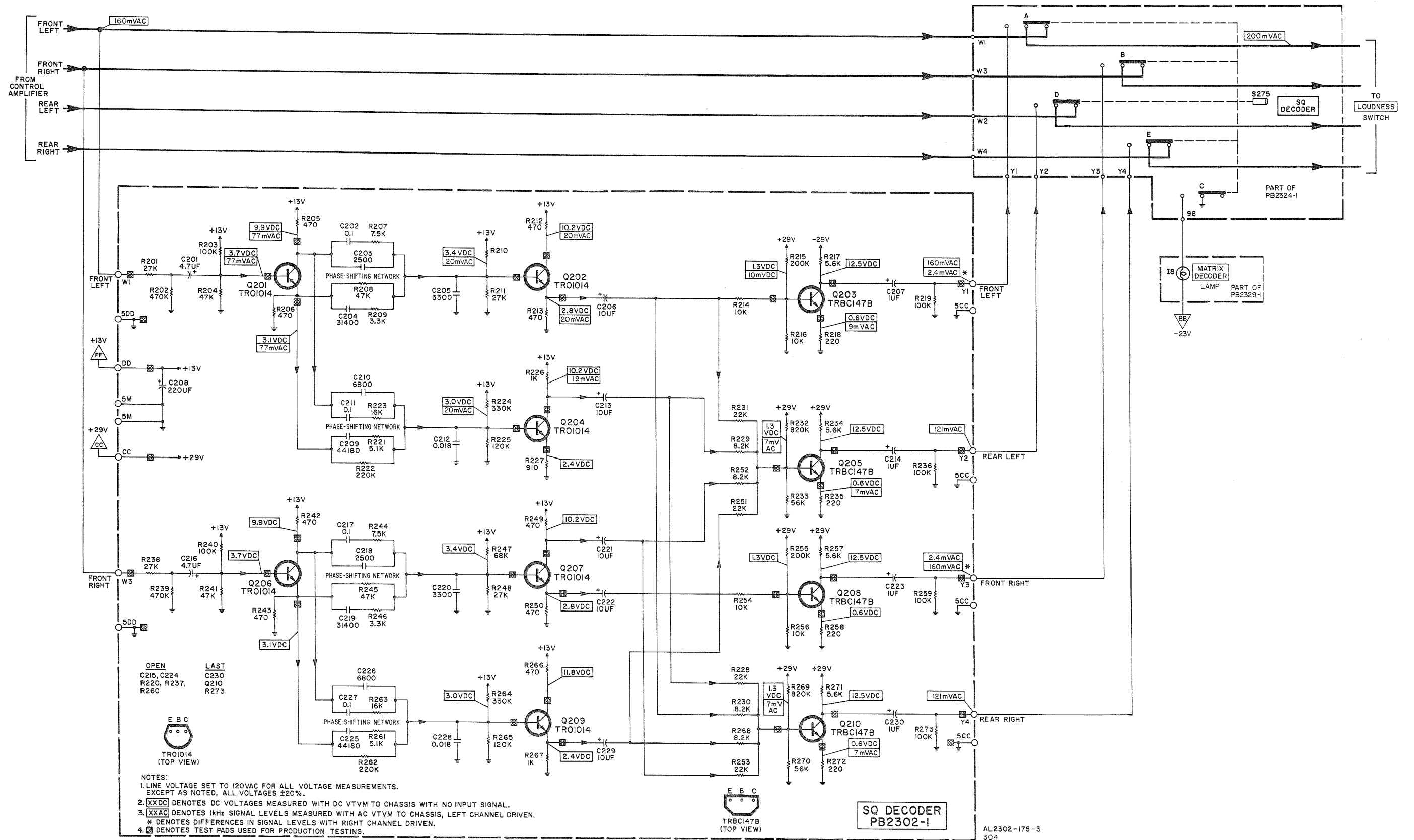

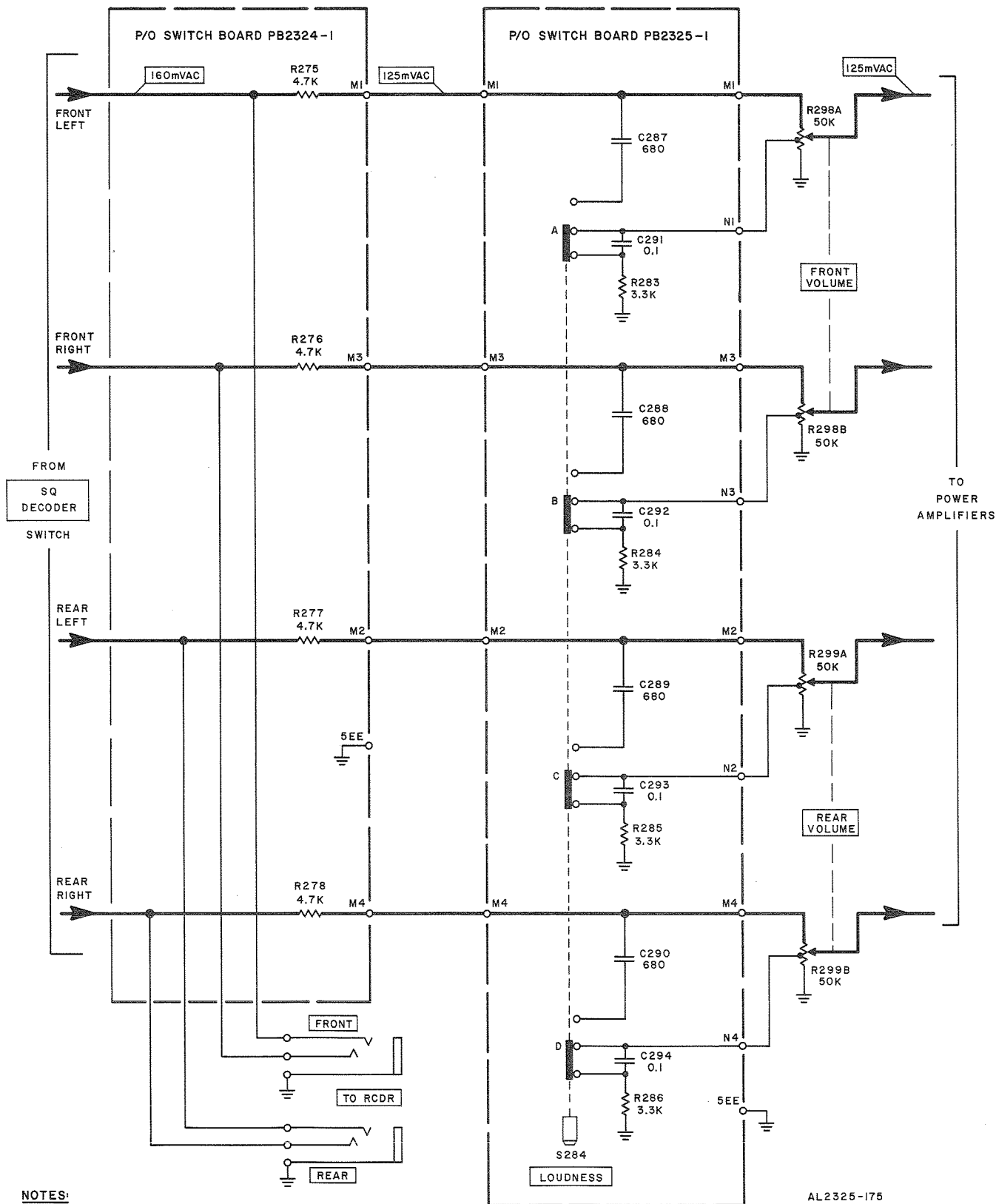

NOTES:

1. LINE VOLTAGE SET TO 120 VAC FOR ALL VOLTAGE MEASUREMENTS. EXCEPT AS NOTED, ALL VOLTAGES $\pm 20\%$.
2. [XXXmVAC] DENOTES 1kHz SIGNAL LEVELS MEASURED WITH AC VTVM TO CHASSIS, VOLUME CONTROLS MAXIMUM.

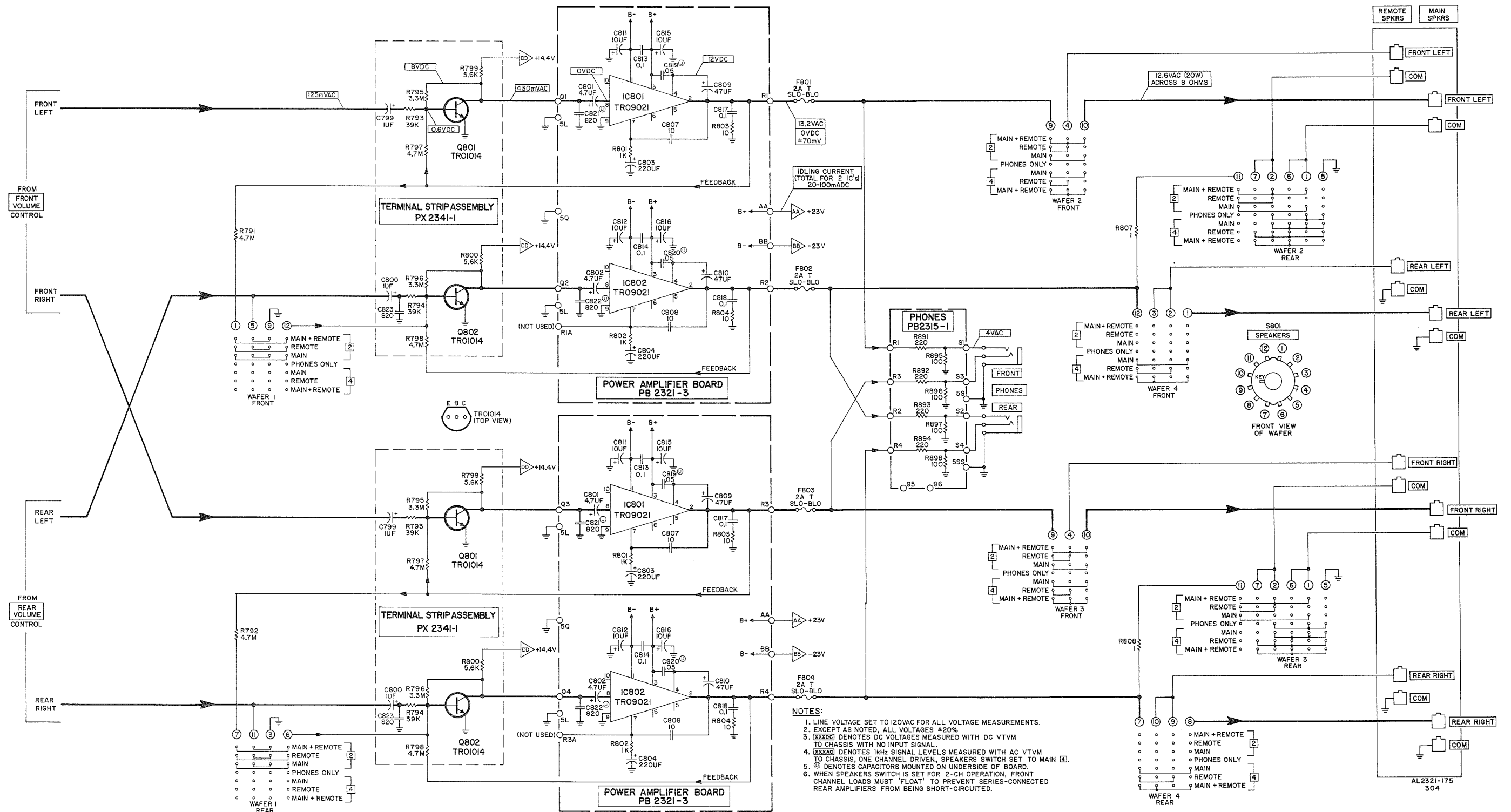

- NOTES:**
1. LINE VOLTAGE SET TO 120VAC FOR ALL VOLTAGE MEASUREMENTS.
 2. EXCEPT AS NOTED, ALL VOLTAGES $\pm 20\%$
 3. $\overline{\text{XXXX}}$ DENOTES DC VOLTAGES MEASURED WITH DC VTVM TO CHASSIS WITH NO INPUT SIGNAL.
 4. $\overline{\text{XXXX}}$ DENOTES 1kHz SIGNAL LEVELS MEASURED WITH AC VTVM TO CHASSIS, ONE CHANNEL DRIVEN, SPEAKERS SWITCH SET TO MAIN [4].
 5. $\textcircled{\text{C}}$ DENOTES CAPACITORS MOUNTED ON UNDERSIDE OF BOARD.
 6. WHEN SPEAKERS SWITCH IS SET FOR 2-CH OPERATION, FRONT CHANNEL LOADS MUST 'FLOAT' TO PREVENT SERIES-CONNECTED REAR AMPLIFIERS FROM BEING SHORT-CIRCUITED.

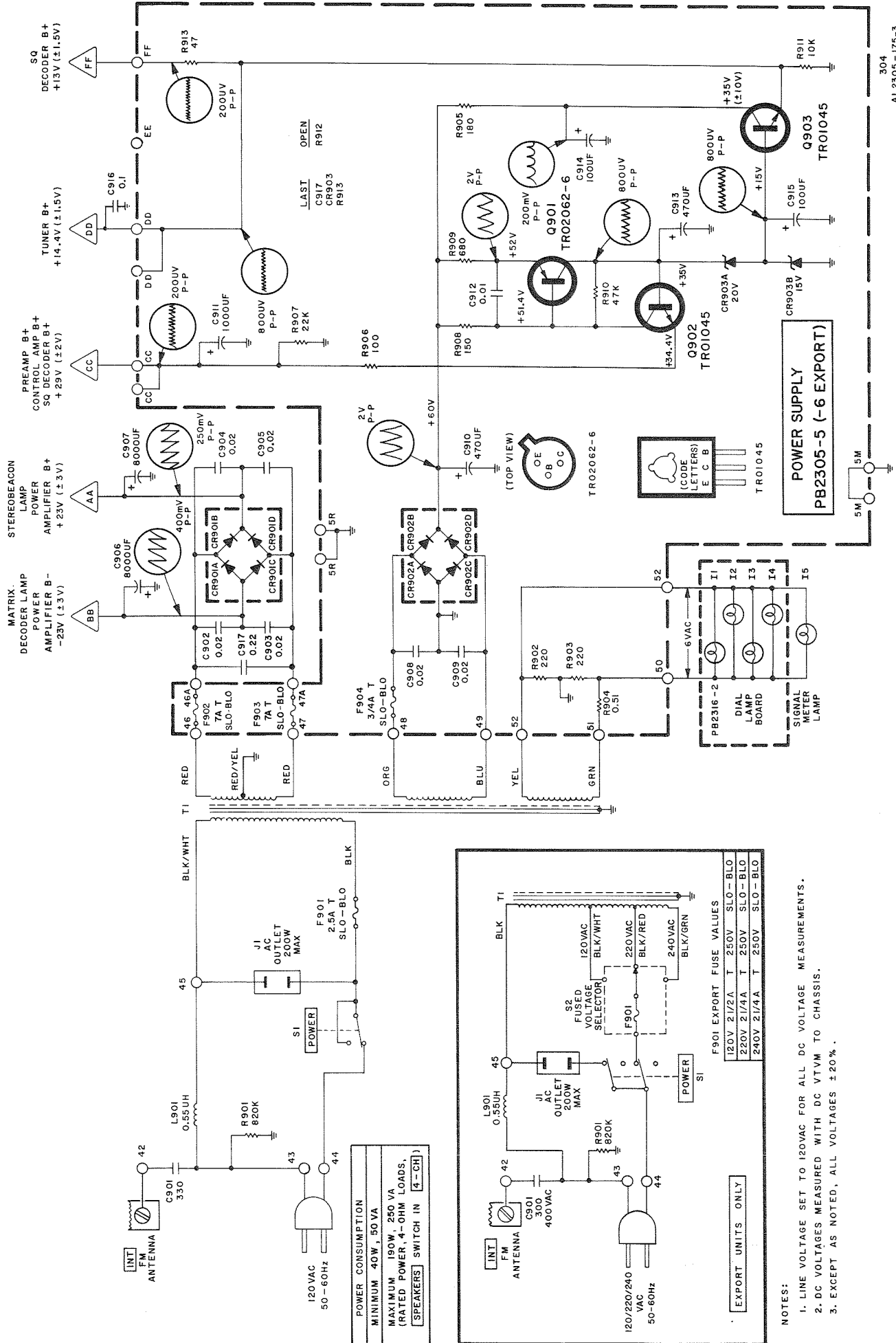

POWER CONSUMPTION

MINIMUM	40W, 50 VA
MAXIMUM	180W, 250 VA
(RATED POWER, 4-6HM LOADS, SPEAKERS SWITCH IN [4-CH])	

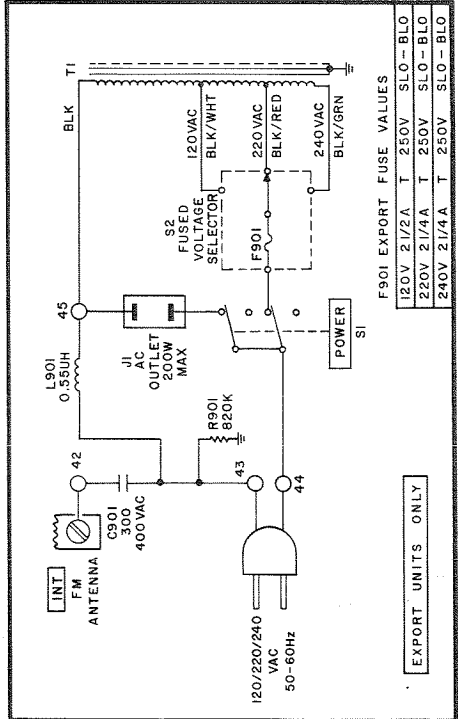

- NOTES:
1. LINE VOLTAGE SET TO 120VAC FOR ALL DC VOLTAGE MEASUREMENTS.
 2. DC VOLTAGES MEASURED WITH DC VTVM TO CHASSIS.
 3. EXCEPT AS NOTED, ALL VOLTAGES ±20%.

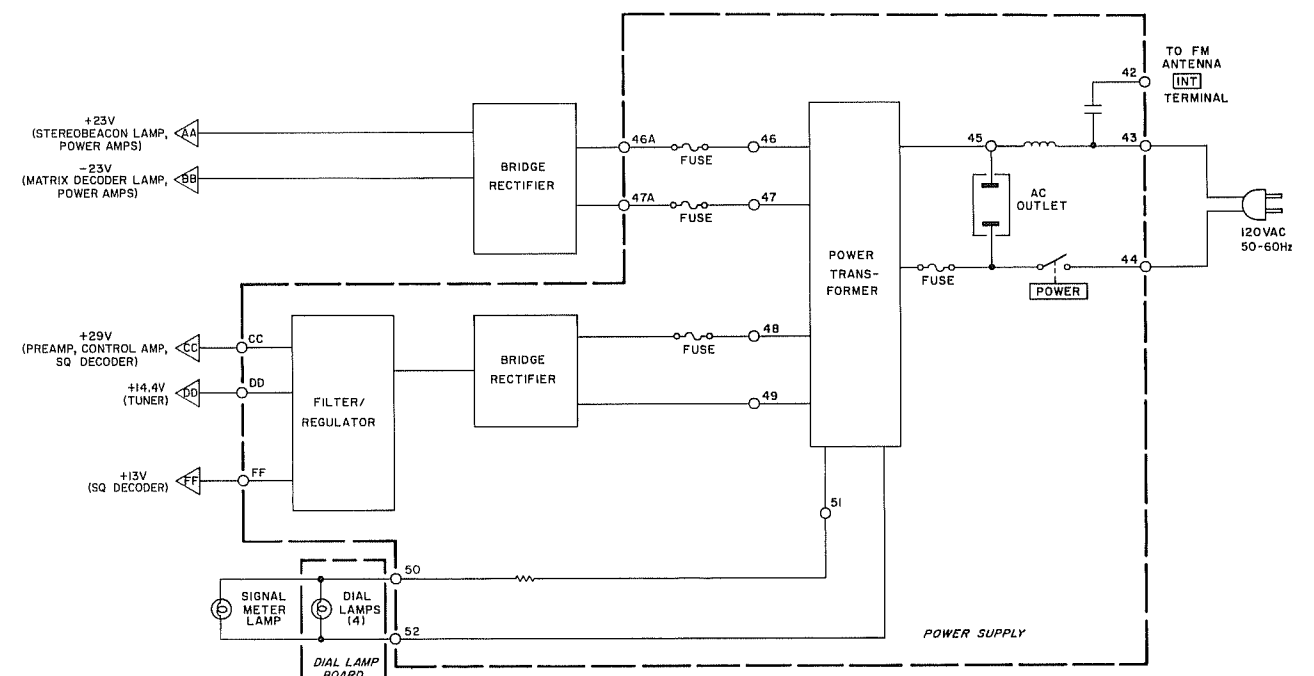
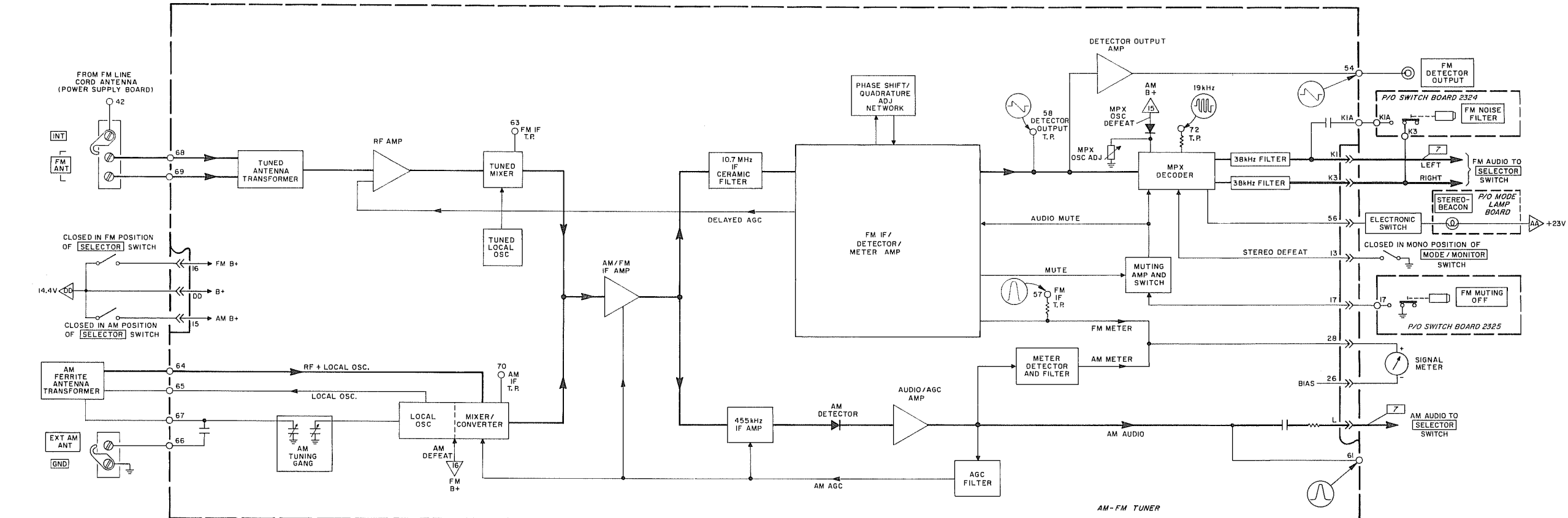

NOTES:
 1. LINE VOLTAGE SET TO 120VAC FOR ALL VOLTAGE MEASUREMENTS. EXCEPT AS NOTED, ALL MEASUREMENTS ±20%.
 2. [XX] DENOTES 1kHz SIGNAL LEVELS (IN MILLIVOLTS) FOR 12.6V OUTPUT ACROSS 8-Ω OHM LOAD, ONE CHANNEL DRIVEN, PUSHBUTTONS OUT, SWITCHES TO 4-CH, REAR VOLUME MINIMUM, 100mV FM, 1kHz AUDIO ±11kHz DEVIATION AT FM ANT TERMINAL, 100mV AM 1kHz AUDIO 16% MODULATION AT EXT AM ANT TERMINAL, GND LINE OPEN.
 3. WHEN SPEAKERS SWITCH IS SET FOR 2-CH OPERATION, FRONT-CHANNEL LOADS MUST FLOAT, TO PREVENT SERIES-CONNECTED REAR AMPLIFIERS FROM BEING SHORT-CIRCUITED.

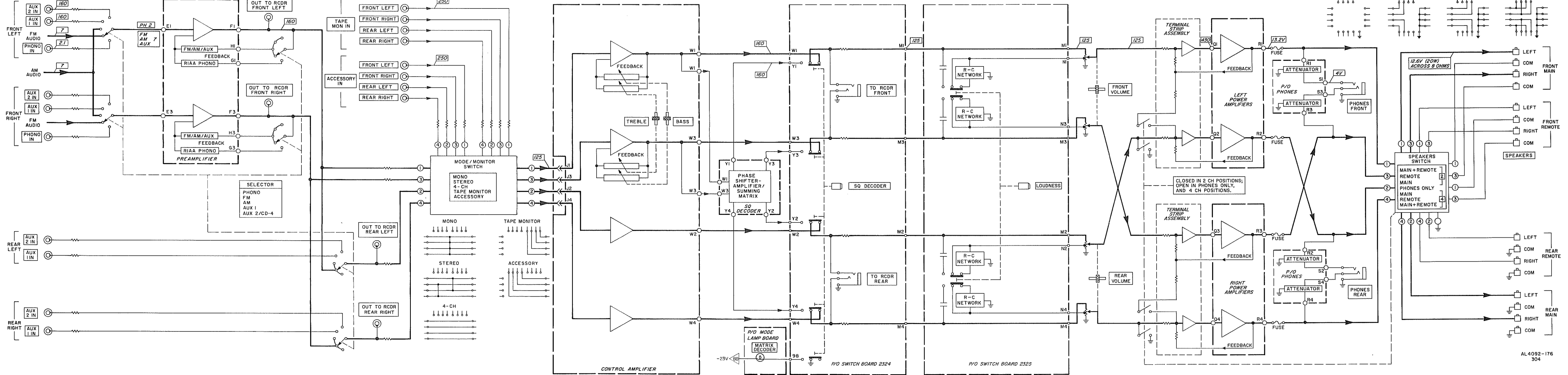

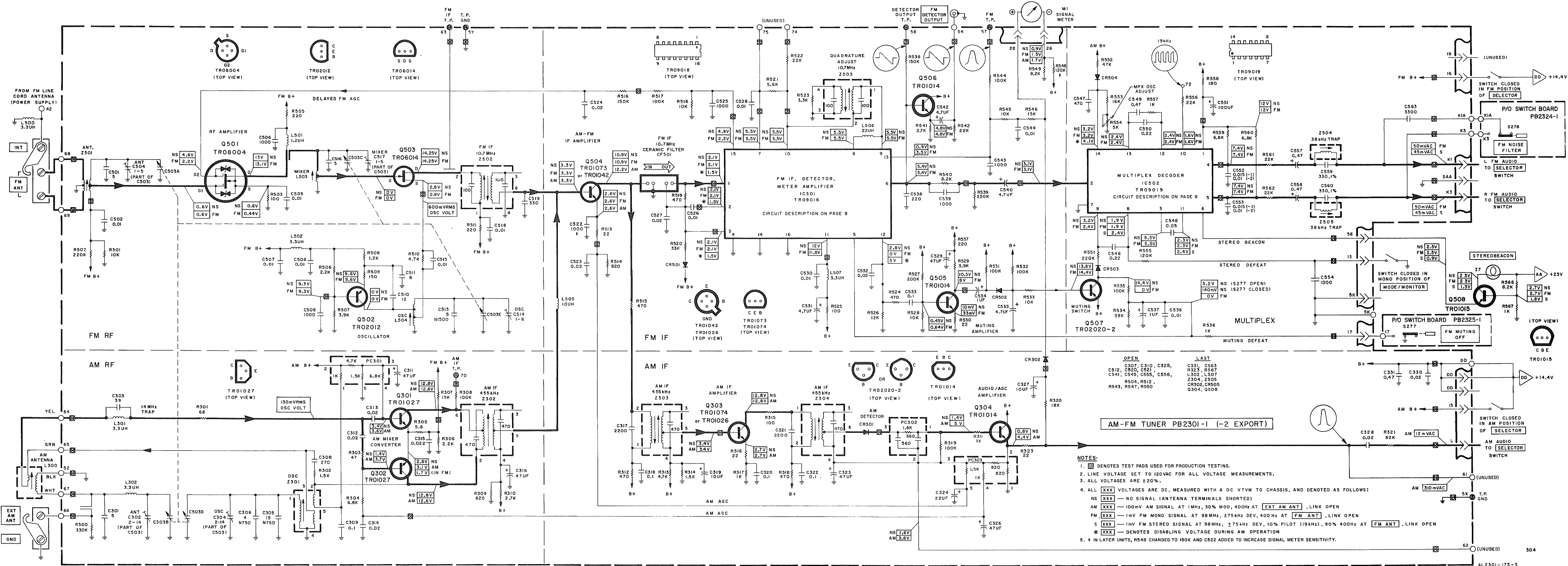

- NOTES:**
- ⊠ DENOTES TEST PADS USED FOR PRODUCTION TESTING.
 - LINE VOLTAGE SET TO 120VAC FOR ALL VOLTAGE MEASUREMENTS.
 - ALL VOLTAGES ARE ±20%.
 - ALL [XXX] VOLTAGES ARE DC, MEASURED WITH A DC VTVM TO CHASSIS, AND DENOTED AS FOLLOWS:
 NS [XXX] — NO SIGNAL (ANTENNA TERMINALS SHORTED)
 AM [XXX] — 100mV AM SIGNAL AT 1MHz, 30% MOD, 400Hz AT [EXT AM ANT], LINK OPEN
 FM [XXX] — 1mV FM MONO SIGNAL AT 98MHz, ±75% DEV, 400Hz AT [FM ANT], LINK OPEN
 S [XXX] — 1mV FM STEREO SIGNAL AT 98MHz, ±75% DEV, 10% PILOT (19kHz), 90% 400Hz AT [FM ANT], LINK OPEN
 * [XXX] — DENOTES DISABLING VOLTAGE DURING AM OPERATION
 - † IN LATER UNITS, R548 CHANGED TO 150K AND C522 ADDED TO INCREASE SIGNAL METER SENSITIVITY.