

# SERVICE MANUAL

PRICE \$2.00

**40**

SERIAL NUMBERS  
BEGINNING 10001

# The Fisher® 40



## Two- and Four-Channel Stereo Home Music Center

*WORLD LEADER IN HIGH QUALITY STEREO*

|                          |    |                       |    |
|--------------------------|----|-----------------------|----|
| REQUIRED TEST EQUIPMENT  | 3  | POWER AMP             | 12 |
| MECHANICAL DISASSEMBLY   | 3  | POWER SUPPLY          | 14 |
| DIAL STRINGING           | 3  | CARTRIDGE PLAYER      |    |
| HARMONIC DISTORTION TEST | 3  | FUNCTIONAL OPERATION  | 16 |
| SIGNAL FLOW              | 4  | PREAMPLIFIER          | 18 |
| CHASSIS LAYOUT           | 5  | ADJUSTMENTS           | 19 |
| TUNER ALIGNMENT          | 6  | DISASSEMBLY           | 20 |
| TUNER                    | 8  | PARTS LIST            | 21 |
| CONTROL-PREAMP           | 10 | TROUBLESHOOTING GUIDE | 22 |

**CAUTION:**

This precision high-fidelity instrument should be serviced only by qualified personnel, trained in the repair of transistor equipment and printed circuitry.

Many of these items are included only as a reminder — they are normal procedures for experienced technicians. Shortcuts may be taken, but these often cause additional damage to transistors, circuit components, or printed circuit boards.

**SOLDERING:** A well-tinned, hot, clean soldering iron tip will make soldering easier, without causing damage to the printed circuit board or the components mounted on it. Regular use of a sponge cleaner will maintain a clean soldering surface. The heat available at the tip, (not the wattage of the iron) is important. Some 50-watt irons reach temperatures of 1,000° F, while others will hardly melt solder. Small-diameter tips should be used for single solder connections, pyramid and chisel tips for large areas.

Always disconnect the AC power cord from the line when soldering. Turning the power switch OFF is not sufficient. Power-line leakage paths, through the heating elements of the iron, may destroy transistors.

**PARTS REMOVAL:** If a part is not being returned for in-warranty factory replacement, it may be cut in half (with diagonal cutting pliers) to make removal easier. Multiple terminal parts, such as IF transformers, or electrolytic capacitors, should be removed using special de-soldering tips made especially for this purpose. Removing solder from terminals, reduces the possibility of breaking the printed circuit board when the part is removed.

**ACCIDENTAL SHORTS:** A clean working area, free of metal particles, screws, etc., is an important preventive in avoiding servicing problems: Screws, removed from the chassis during servicing, should be stored in a box until needed. While a set is operating, it takes only an instant for a base-to-collector short to destroy a transistor (and others direct-coupled to it). In the time it takes for a dropped screw, washer, or screw-driver, to contact a pair of terminals (or terminal and chassis), a transistor can be ruined.

**SOLID-STATE DEVICES:** Integrated Circuits contain the equivalent of many circuit parts, including transistors, diodes, resistors, and capacitors. The preferred troubleshooting procedure requires isolating the trouble to one stage using AC signal tracing methods. Once the suspected stage is located the DC voltages at the input and output leads are measured to give an accurate indication of the operating conditions of the IC. DO NOT use an ohmmeter, to check continuity with the IC mounted on the printed circuit board. Forward biasing the internal junctions within the IC may burn out the transistors. Do not replace a defective IC until all external resistors, capacitors, and transformers are checked first, to prevent the replacement IC from failing immediately due to a defect in the connecting components. Solder and unsolder each lead separately using a pliers or other heat sink on the lead to

prevent damage from excessive heat. Check that the leads are connected to the correct locations on the printed circuit board before turning the set on.

Whenever possible, a transistor tester should be used to determine the condition of a transistor or diode. Ohmmeter checks do not provide conclusive data, and many even destroy the junction(s) within the device.

Never attempt to repair a transistor power amplifier module until the power supply filter-capacitors are fully discharged.

If an output or driver transistor becomes defective (opens or shorts), always check ALL direct-coupled transistors and diodes in that channel. In addition, check the bias pot., and other parts in the bias network, before installing replacement transistors. All output and driver transistors in one channel may be destroyed if the bias network is defective. After parts replacement, check bias for specified idling current.

In some applications, replacement of transistors must be made from the same beta group as the original type. The beta group is indicated by a colored marking on the transistor. Include this information when ordering replacements.

When mounting a replacement power transistor, be sure the bottom of the flange, mica insulator, and the surface of the heat sink, are free of foreign matter. Dust and grit will prevent flat contact, reducing heat transfer to the heat sink. Metallic particles can puncture the insulator, cause a short, and destroy the transistor.

Silicone grease must be used between the transistor and the mica insulator and between the mica and the heat sink for best heat transfer. Use Dow-Corning DC-3, or an equivalent compound made for power transistor heat conduction.

Use care when making connections to speakers and output terminals. To reduce the possibility of shorts, lugs should be used on the exposed ends, or stranded wire should be tinned to prevent frayed wire ends. Current in the speakers and output circuitry is quite high — poor contacts, or small wire, can cause significant power losses. For wire lengths greater than 30 feet, 16 AWG, or heavier, should be used.

**VOLTAGE MEASUREMENTS:** All voltages are measured with the line voltage adjusted to 120 volts. All measured voltages are  $\pm 20\%$ . DC voltages are measured to chassis with a VTVM, with no signal input unless otherwise noted. AC signal voltages are measured under the conditions specified on the schematic.

**ALIGNMENT PROCEDURES:** DO NOT attempt realignment unless the required test equipment is available, and the alignment procedure is thoroughly understood.

The following equipment is required to completely test and adjust the 40 Home Music Center

- Line Voltage Autotransformer or Voltage Regulator
- DC Vacuum Tube Voltmmeter
- Accurately Calibrated AC Vacuum Tube Voltmeter
- Oscilloscope (Flat to 100 kHz Minimum)
- Low-Distortion Audio (Sine Wave) Generator
- Harmonic Distortion Analyzer
- 2 —Load Resistors, 4-Ohms, 100 Watt (Minimum Rating)
- AM-FM Signal Generator
- 10.7 MHz Sweep Generator (Fisher 3024\*)
- Multiplex Generator with RF output (Fisher 1536\*)
- 455 kHz Sweep Generator (Fisher 3025\*)
- Test Cartridges — 2 and 4 Channel
- Soldering iron with Small Tip, Fully Insulated from AC Line
- Suction Desoldering Tool

\* with Power Supply (Fisher 1561)

**PLEASE READ CAREFULLY:** The parts lists on this and following pages do not include shipping charges. Please include the serial number of the Fisher equipment for which the part(s) are intended. Send your order to:

PARTS DEPARTMENT, FISHER RADIO, 11-40 45th Road, Long Island City, N. Y. 11101.

## MAIN CHASSIS

| Symbol | Description                          | Part No.   | Sug. Ret. | Symbol         | Description   | Part No.     | Sug. Ret. |
|--------|--------------------------------------|------------|-----------|----------------|---|--------------|-----------|
| --     | AC Outlet                            | JK20665    | .65       | --             | Panel, Left Side (Walnut)   | KE4058-109-1 | 6.30      |
| --     | Adhesive Pad (for Meter)             | EM51293    | .30       | --             | Panel, Right Side (Walnut)  | KE4058-109-2 | 6.30      |
| --     | Antenna, Dipole (FM)                 | LA51319-1  | 1.45      | --             | PCB AM-FM Tuner   | PB2287-1     | 104.50    |
| --     | Cartridge, Phono (Pickering V15/AT2) | GT21352    | 20.25     | --             | PCB Control-Preamplifier  | PB2247-1     | 82.30     |
| --     | Channel Rubber                       | A670-137   | .40       | --             | PCB 2+2 Channel Decoder   | PB2289-2     | 7.25      |
| --     | Connector, Changer (4 Terminal)      | J50375-4   | .45       | --             | PCB Volume Control  | PB2284-1     | 12.30     |
| --     | Cover, AM Antenna                    | EM4058-156 | .35       | --             | PCB Power Amplifier   | PB2291-1     | 45.70     |
| --     | Cover, Top                           | AA4058-127 | 2.40      | --             | PCB Power Supply  | PB2245-1     | 23.45     |
| --     | Dial Drum Assembly (Tuner)           | AS2287-    | .85       | --             | *PCB Power Supply   | PB2245-2     | 23.85     |
|        |                                      | 23400011   |           | --             | Retainer, Dial Glass  | AB4058-125   | .40       |
| --     | Dial Glass, Screened                 | AS4058-108 | .60       | --             | Retainer, Lamp Assembly   | AN4058-149   | .65       |
| --     | Dial Pointer Assembly                | AS20506    | 2.90      | --             | Retainer Wire (Meter)   | AN4058-147   | .35       |
| --     | Door (Tape Cartridge Insert)         | AD51367    | 1.15      | --             | Rod, Hinge (Tape Cartridge Insert Door)                           | AN51350      | .55       |
| --     | Dress Panel Assembly                 | AS4058-137 | 28.00     | --             | Rubber Strip (Dial Glass)   | EM51290      | .40       |
| --     | Foot, Molded                         | A51A147    | .45       | --             | Speed Clip (Tape Cartridge Insert Door)                           | HH21750      | .50       |
| --     | Fuse Holder                          | X51B080    | 1.35      | --             | Spring, Dial Drum   | AN2287-      | .35       |
| --     | Grommet, Rubber                      | A1059-119  | .35       |                |   | 11403381     |           |
| --     | Jack, FM Detector Out                | J50465     | .40       | --             | *Switch, Voltage Selector   | SR51304-1    | 1.65      |
| --     | Jack, Phones, Ext Recorder Out       | JK20627-5  | 1.10      | --             | Terminal Board, Antenna   | ET51394      | 1.15      |
| --     | Jack Strip, Input Output (12 jacks)  | JK20691    | 3.00      | --             | Terminal Board, Speakers  | ET51340-1    | 5.10      |
| --     | Knob:                                |            |           | --             | Torsion Spring (Tape Cartridge Insert Door)                       | AN51351      | .30       |
|        | Pushbutton                           | EK20021-3  | .50       | --             | Tuning Shaft Assembly   | AS20719      | 2.25      |
|        | Volume                               | EK20040    | .60       | C50            | Ceramic, 1 pF, ±0.25 pF, 500V                                     | C51188-1     | .35       |
|        | Tuning                               | EK20035    | .50       | C283           | Ceramic, 3900 pF, 10%, 500V                                       | C51B189-17   | .40       |
|        | Mode/Ext Mon, Selector               | EK20036    | .50       | F1             | Fuse, 3.2A, 125V, Slo-Blo   | F151313-6    | .65       |
|        | Dual Outer — Balance, Bass, Treble   | EK20037    | .50       | *F1            | Fuse, 1.6A, 250V, Slo-Blo   | F51B247-17   | .60       |
|        | Dual Inner — Balance, Bass, Treble   | EK20038    | .70       | *F1            | Fuse, 3.5A, 250V, Slo-Blo   | F51B247-21   | .60       |
| --     | Lamp, 28V, 40mA (for Lamp Assembly)  | LM21436-3  | .60       | L9             | Antenna Ferrite (AM)  | LA2287-114-1 | 2.65      |
| --     | Lamp Assembly (4 lamps)              | AS21433-1  | 8.65      | L10            | Choke, RF, 3.3 uH   | LC21814-2    | .55       |
| --     | Lamp Assembly (6 lamps)              | AS21431-2  | 12.00     | M1             | Meter, Indicating   | MC21613      | 7.10      |
| --     | Lamp Assembly, Dial Glass            | AS21410-5  | 1.05      | R61            | Composition, 270, 10%, ½W   | RC20BF271K   | .30       |
| --     | Lamp Assembly, Dial Pointer          | AS21413-2  | 1.05      | R62            | Composition, 330K, 10%, ½W  | RC20BF334K   | .30       |
| --     | Lamp Assembly, Stereobeacon, Meter   | AS21419-3  | 3.85      | S1, 2, 3, 4, 5 | Switch, Power, Speakers, Muting Off, Loudness (5-switch Assembly) | SP50200-52-1 | 6.65      |
| --     | Lens, Cartridge, Receiver Mode (Red) | EA21425-4  | .25       | S6, S7         | Switch, 2 ÷ 2 Decoder (2-switch Assembly)                         | SP50200-55   | 3.20      |
| --     | Line Cord                            | W50023-1   | 1.25      | S8, S9         | Switch, Repeat-Consec, Change (2-switch Assembly)                 | SP50200-51   | 2.65      |
| --     | Motor Board Assembly                 | AS4058-138 | 5.00      | T1             | Transformer, Power  | TD4058-115   | 19.20     |
| --     | Nameplate '40'                       | NP22641-1  | .75       | *T1            | Transformer, Power  | TD4058-215   | 29.55     |
| --     | Nameplate Turntable (BSR)            | N20A267    | .40       |                |   |              |           |

\* Used in Export Units Only

BECAUSE ITS PRODUCTS ARE SUBJECT TO CONTINUOUS IMPROVEMENT, FISHER RADIO RESERVES THE RIGHT TO MODIFY ANY DESIGN OR SPECIFICATION WITHOUT NOTICE AND WITHOUT INCURRING ANY OBLIGATION.

PRICES SUBJECT TO CHANGE WITHOUT NOTICE

## CHASSIS ACCESS

For access to the chassis for servicing, remove motorboard and top cover (if necessary) as follows:

### REMOVING MOTORBOARD

- (1) Unplug AC power cord.
- (2) Unscrew two large shipping screws near left-rear and right-front corners of the turntable baseplate so that they are fully out. This will lock the turntable to motorboard.
- (3) Remove four screws (two on each side) holding the motorboard to chassis. Remove two screws from top of dress panel in front of motorboard.
- (4) Lift motorboard at rear and disconnect motor connector and audio cables from underside of turntable. Remove motorboard from top of chassis.
- (5) Reverse procedure to reinstall motorboard. Red plug designates the right channel.

### REMOVING TOP COVER AND CARTRIDGE PLAYER

Access to the cartridge player, 2+2 decoder, or right section of control-preamplifier board is as follows:

- (1) Remove motorboard.
- (2) Remove two screws securing the top cover at the rear of chassis. Remove the screw from top of dress panel above cartridge player.
- (3) For access to right section of control-preamplifier board, remove four screws holding cartridge player brackets and slide player towards rear of chassis. Label and disconnect leads at cartridge player to remove player from chassis.
- (4) Reverse procedure to reinstall cartridge player.

### REMOVING DRESS PANEL

- (1) Unplug AC power cord.
- (2) Gently pull VOLUME, BALANCE, BASS, TREBLE, MODE/EXT TAPE MONITOR, SELECTOR and TUNING knobs from their shafts.
- (3) Remove motorboard and top panel. Remove four screws from bottom of dress panel and remove dress panel.
- (4) Reverse procedure for reassembly.

### REPLACING DIAL AND METER LAMPS AND METER

The dial glass assembly must be removed for access to dial lamps, dial pointer assembly (and lamp), meter and STEREO-BEACON lamps, and tuning meter.

- (1) Remove dress panel.
- (2) Remove four screws securing dial glass assembly to supporting bracket on front panel assembly.
- (3) Label and disconnect lamp and meter wires to permit the dial glass assembly to swing forward for access or to be removed.
- (4) To replace dial lamps, snap out defective lamp assembly from the rear of dial glass bracket and insert a new one.
- (5) To replace dial pointer assembly or dial pointer lamp, label and disconnect lamp leads, carefully disengage pointer assembly and pull it free of bracket. Snap out lamp housing and remove. Check pointer adjustment after reassembly. Refer to DIAL STRINGING procedure.
- (6) To replace STEREOBEACON or meter lamps, the lampholder assembly must be replaced as a unit. Label and disconnect lampholder leads, pull up lampholder retaining spring, and remove lampholder. Install a new lampholder and insert retaining spring to hold it against rear of meter.
- (7) To replace tuning meter, label and disconnect meter leads, remove lampholder assembly from rear of meter, and gently pry meter from back of panel. Scrape residual adhesive from panel. Transfer meter leads to new meter. Align meter face over panel cutout and press firmly to back of panel. Reinstall lampholder at rear of meter. Check meter calibration after reassembly. Refer to TUNER ALIGNMENT.
- (8) Replace dial glass assembly in reverse order.

### REPLACING DIAL GLASS

- (1) Remove dress panel.

- (2) Remove left and right dial glass retainers and remove dial glass.

### REPLACING RECEIVER MODE OR CARTRIDGE LAMPS

Four lamps are contained in the RECEIVER MODE lamp assembly. Similarly, six lamps are contained in the CARTRIDGE lamp assembly. Both must be replaced as complete units.

- (1) Remove motorboard, top cover, and dress panel.
- (2) Label and disconnect leads from control-preamplifier board (MODE lamps) or cartridge player.
- (3) Remove lampholder from its retainer. Install a new lampholder and reconnect wiring.
- (4) Reassemble dress panel, top cover, and motorboard.

### REMOVING PC BOARDS AND SWITCH ASSEMBLIES

Remove the motorboard and top cover for access to boards. To remove boards, disconnect leads and remove screws securing the board to its mounts. Label all wires for reference. Points to note are as follows:

The power amplifier heat sinks are secured to the rear skirt of the chassis with five screws. These must be removed to remove the board. When removing the tuner board, access to the dial drum is required. Remove the screw securing the plate on which the AM antenna is mounted for access. Remove the dial cord. Refer to DIAL STRINGING procedure to replace the dial cord.

### CONTROL-PREAMPLIFIER

The control-preamplifier requires additional procedures for its removal as follows:

- (1) Remove the motorboard and top cover.
- (2) Remove four screws holding cartridge player brackets and move cartridge player towards the rear of chassis. The player can be secured in this position by inserting a mounting screw in one of the holes provided in the chassis.
- (3) Label and disconnect the wires from pins 50 and 51 on power supply board, and pins 28, 56, and DD from control-preamplifier board. These are the wires interconnecting the terminal board at rear of front panel assembly.
- (4) Remove RECEIVER MODE and CARTRIDGE lamp assemblies from their holders.
- (5) Tape dial cord to pulleys at tuner and at rear of panel of assembly. This will keep dial cord in place during removal of panel assembly (otherwise dial cord will have to be restrung).
- (6) Remove four screws securing front panel assembly to chassis, and carefully place it on top of chassis.
- (7) Label all wiring to control-preamplifier and disconnect.
- (8) Remove two screws holding 2+2DECODER and CARTRIDGE PROGRAM CONTROL switches to the front chassis skirt. Push switch assemblies through the cutout and place them aside clear of control shafts.
- (9) Remove four screws securing the bracket which mounts front panel controls to front chassis skirt.
- (10) Place unit on its side and remove five screws that secure front chassis skirt to chassis (bottom plate). Pull chassis skirt forward to clear control shafts.
- (11) Remove screws securing control-preamplifier board to its mounts. Carefully lift it clear of the chassis.
- (12) Replace in reverse order. Refer to DIAL STRINGING procedure if necessary.

### PUSHBUTTON SWITCH ASSEMBLIES AND VOLUME BOARD

For access to or removal of pushbutton switch assemblies or volume board, follow steps (1) through (6) of control-preamplifier removal. Label wires for reference and disconnect them. Two screws secure the assemblies to the front chassis skirt. Replace in reverse order.

### CAUTION:

- (A) Test one channel at a time.
- (B) Limit tests to 10 minutes.
- (C) Use a load with a minimum power rating of 100 watts.

- (1) Unplug AC power cord and release all pushbuttons. Slide FRONT and REAR VOLUME controls to MIN. Set BASS, TREBLE and BALANCE to their center positions. Set MODE/EXT TAPE MONITOR to 4-CH STEREO, SELECTOR to AUX, and depress MAIN SPKRS pushbutton.
- (2) Connect a low-distortion sine wave generator to the FRONT L AUX IN jack. Set generator frequency to 1kHz, and the output level to minimum.
- (3) Connect a 4-ohm load resistor between MAIN SPKRS FRONT L and COMMON terminals. Connect a harmonic distortion analyzer across the load.
- (4) Connect AC power cord and depress POWER ON pushbutton. Slide FRONT VOLUME to MAX.
- (5) Increase generator output for 20 watts RMS (8.9V across 4-ohm load). HD meter should indicate 1% or less.
- (6) Repeat preceding steps for FRONT R, REAR L, and REAR R channels.

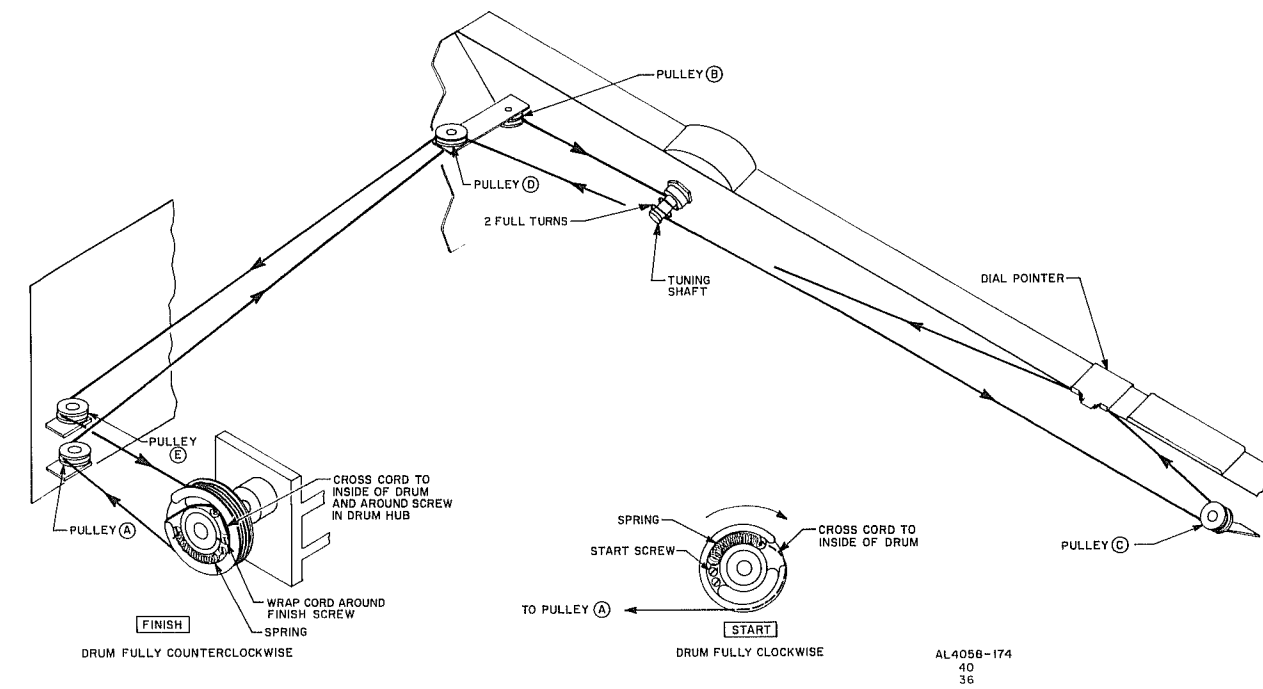

AL4058-174  
40  
36

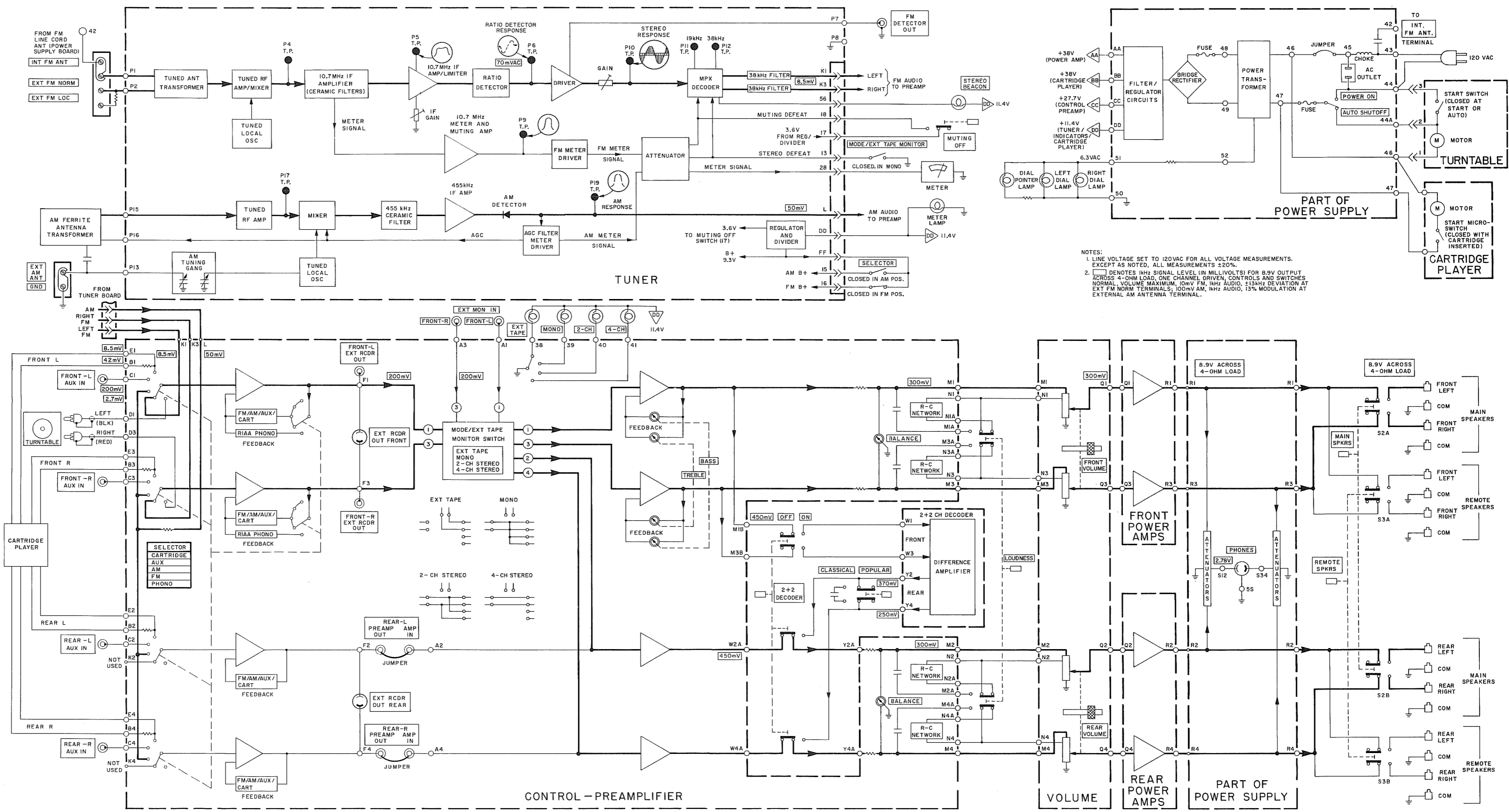

NOTES:  
 1. LINE VOLTAGE SET TO 120VAC FOR ALL VOLTAGE MEASUREMENTS. EXCEPT AS NOTED, ALL MEASUREMENTS  $\pm 20\%$ .  
 2.  $\square$  DENOTES 1kHz SIGNAL LEVEL (IN MILLIVOLTS) FOR 8.9V OUTPUT ACROSS 4-OHM LOAD, ONE CHANNEL DRIVEN, CONTROLS AND SWITCHES NORMAL VOLUME MAXIMUM, 100mV FM, 1kHz AUDIO,  $\pm 13\%$  DEVIATION AT EXT FM NORM TERMINALS; 100mV AM, 1kHz AUDIO, 13% MODULATION AT EXTERNAL AM ANTENNA TERMINAL.

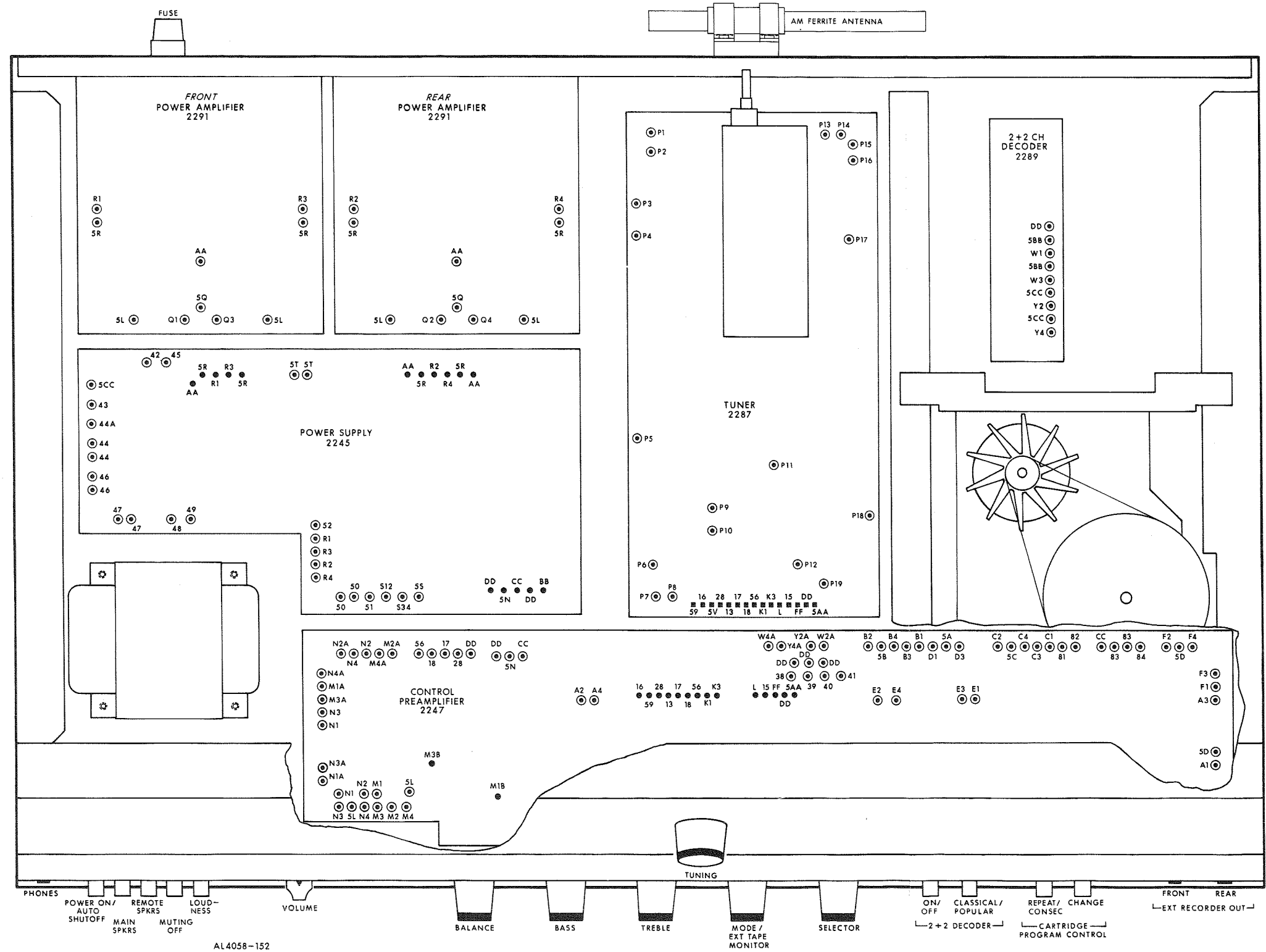

AL4058-152  
CHASSIS LAYOUT  
40

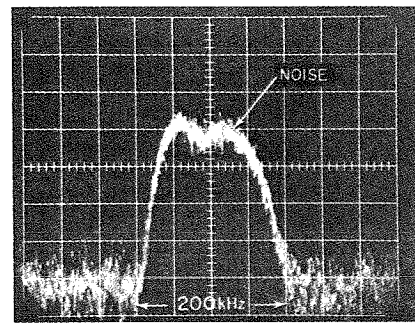
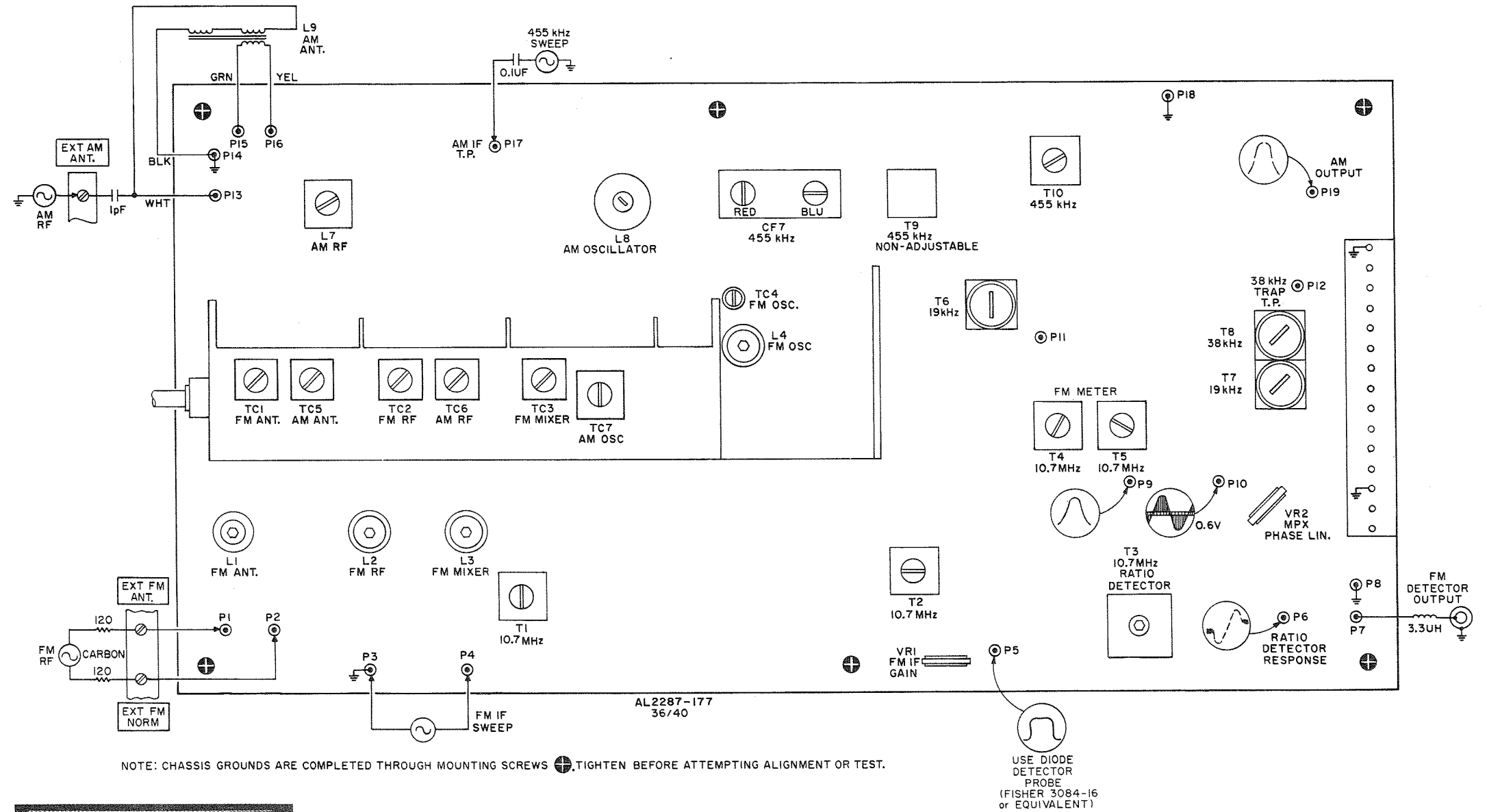

FM IF : A

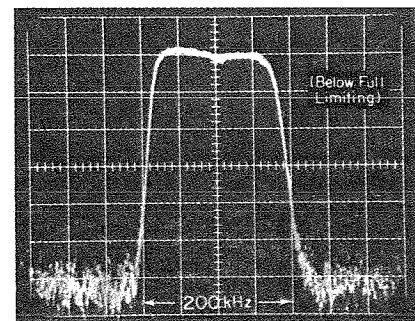

FM IF : B

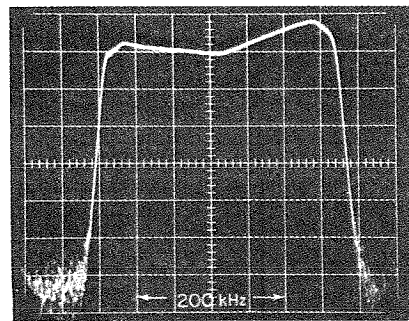

FM IF LIMITED

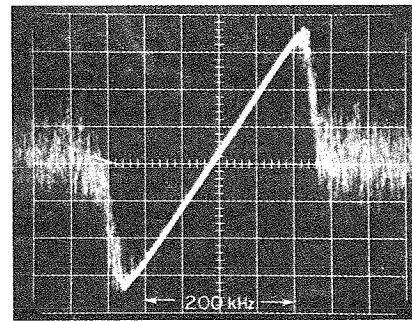

FM DETECTOR

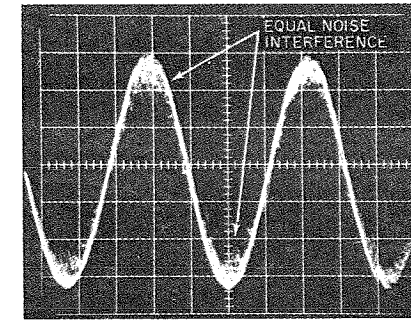

SYMMETRICAL TUNING

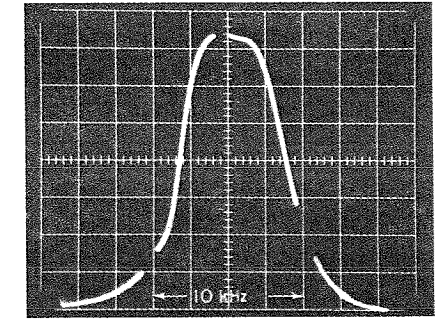

AM IF

# TUNER ALIGNMENT

FM ALIGNMENT — SELECTOR to FM, MODE/EXT TAPE MONITOR to MONO, MUTING OFF depressed, FRONT and REAR VOLUME to 0.

Maintain generator output as low as possible for suitable indication.

| GENERATOR  | DIAL SETTING   | INDICATOR   | PROCEDURE   |
|--|--|---|---|
| <p><b>Note:</b> FM IF circuits utilize non-tunable ceramic filters which establish the IF bandpass. To insure symmetrical tuning and selectivity, the IF's must be aligned precisely to the center of the IF bandpass, rather than to 10.7 MHz as in conventional LC circuits.</p> |  |   |   |
| 1. IF  | Connect 10.7MHz sweep to pin P4, gnd to P3. Markers are not required.  | Position of non-interference                      | Scope vert input to pin P5, gnd to P3. Use diode detector probe.* Adjust FM IF GAIN VR1, T1 and T2 for max gain and best symmetry. Keep signal low enough for noise on response as shown in FM IF, RESPONSE A.                |
| 2.   | Increase output for signal just below full limiting.   | Position of non-interference                      | If necessary readjust T1 and T2 for good symmetry. SEE FM IF, RESPONSE B.   |
| 3. DETECTOR  | 10.7 MHz sweep to P4, gnd to P3. Adjust for S-curve display.   | Position of non-interference                      | Adjust T3 bottom and top slugs for max gain and best symmetry. SEE FM DETECTOR RESPONSE. Note: Minimum THD and Maximum Meter alignment must be performed as part of Detector alignment.                                       |
| <p>NOTE: 120-ohm composition resistors in series with each lead from RF generator match 50-ohm output to 300-ohm input impedances. Generator output voltage is reduced to one-half at antenna terminals. Signal voltages are generator output levels, not antenna voltages.</p>    |  |   |   |
| 4. METER   | Sweep generator as connected in step 2. FM generator to FM ANTenna terminals through 120-ohm resistors. Turn modulation off. Slowly increase output and vary frequency for marker at center of IF response curve. Turn off sweep and adjust FM generator output for panel meter reading of approx 3. | Position of non-interference                      | Front panel meter<br>Adjust T4 and T5 for max deflection. Reduce generator output to keep meter at approx 3.  |
| 5. FRONT END   |  | Tuning knob fully CCW.                            | Center dial pointer on 0 and cement.  |
| 6.   | FM generator to FM ANTenna terminals through 120-ohm resistors. Set to 90 MHz. Adjust output for approx 3 on meter.  | Center of 90 MHz calibration mark on dial.        | Front panel meter<br>Adjust L4, L3, L2, L1 for max deflection. Reduce generator output to keep meter at approx 3.   |
| 7.   | Set to 106 MHz   | Center of 106 MHz calibration mark on dial.       | Front panel meter<br>Adjust TC4, TC3, TC2, TC1 for max deflection. Reduce generator output to keep meter at approx 3. Repeat steps 6 and 7 for max signal and accurate dial calibration.                                      |
| 8. MAX METER   | Set to position of non-interference near 98 MHz. Modulate with 400 Hz, $\pm 75$ kHz deviation. Vary frequency to peak meter reading. Keep output at approx 3.5.  | Tune to generator.                                | Scope vert input to FRONT-L EXT RCDR OUT jack.<br>Reduce generator output for noise visible on sine wave. Readjust generator frequency to center noise on positive and negative half cycles. SEE SYMMETRICAL TUNING RESPONSE. |
| 9.   | Set generator for CW output at 2 mV.   | Tune to generator.                                | Front panel meter<br>Meter deflection should be between 4 and 5. (No adjustment.)<br>Note: Do not change generator or receiver tuning; proceed with Min THD adjustment.   |
| 10. MINIMUM THD  | Modulate with 400 Hz, $\pm 75$ kHz deviation.  | AC VTVM and HD analyzer to FRONT-L RCDR OUT jack. | Adjust T3 top and bottom for max output and minimum distortion. Output should be from 0.8 to 1.8 VRMS; distortion should be below 0.8%.   |

| GENERATOR                      | DIAL SETTING  | INDICATOR         | PROCEDURE   |
|--------------------------------|---|-------------------|---|
| 11. MUTING                     | Position of non-interference near 98 MHz. Modulate with 400 Hz, $\pm 22.5$ (or 25) kHz deviation. Set output at 2 mV.   | Tune to generator | AC VTVM and scope vert input to FRONT-L RCDR OUT jack.<br>Release MUTING OFF pushbutton. Panel meter should be between 4 and 5.<br>Reduce generator output until audio signal disappears on scope trace; generator output should be less than 45 mV. Increase generator output to 60 $\mu$ V, audio should reappear. Depress MUTING OFF pushbutton. |
| 12. 19 kHz PILOT               | FM generator with composite multiplex signal at EXTERNAL MODULATION input. Modulate with 19 kHz pilot (10%), 400 Hz audio (90%), left channel only. Set for 42.5 kHz deviation and 2 mV output. | Tune to generator | Scope vert AC input to pin P11.<br>Set MODE/EXT TAPE MONITOR to 4-CH STEREO. Adjust T6 and T7 for max amplitude.  |
| 13. 38 kHz TRAP, STEREO-BEACON | FM generator with composite multiplex signal at EXTERNAL MODULATION input. Modulate with 19 kHz pilot (10%), 400 Hz audio (90%), left channel only. Set for 42.5 kHz deviation and 2 mV output. | Tune to generator | Scope vert input to P12.<br>Adjust T8 for max amplitude. STEREOBEACON lamp should be on.  |
| 14. SEPARATION                 | FM generator with composite multiplex signal at EXTERNAL MODULATION input. Modulate with 19 kHz pilot (10%), 400 Hz audio (90%), left channel only. Set for 42.5 kHz deviation and 2 mV output. | Tune to generator | AC VTVM to FRONT-L RCDR OUT jack, another to FRONT-R RCDR OUT jack.<br>Readjust T6 for max on left channel. Adjust T8 and VR2 (MPX PHASE LINEARITY) for best separation.<br>Modulate right channel only. If necessary, readjust T8 and VR2 for best separation.   |

AM ALIGNMENT — SELECTOR to AM, MODE/EXT TAPE MONITOR to MONO, FRONT and REAR VOLUME to 0.

Maintain generator output as low as possible for suitable indication.

| GENERATOR    | DIAL SETTING   | INDICATOR                                    | PROCEDURE   |
|--------------|--|--|---|
| 1. IF        | 455 kHz sweep generator to pin P17, gnd to P14. Use 0.1 $\mu$ F capacitor in series with generator lead.           | Position of non-interference.                | Scope to pin P19, gnd to P18. Use low capacitance probe.<br>Adjust both T10 and CF7 for max gain and best symmetry. Maximum response can be $\pm 2.5$ kHz from IF center frequency (455 kHz). See AM IF RESPONSE. |
| 2. FRONT END | AM generator to EXT AM ANT and GND terminals. Open GND link. Set to 600 kHz. Modulate with 400 Hz, 30% modulation. | Center of 600 kHz calibration mark on dial.  | Front panel meter.<br>Adjust L7 and L8 for max deflection. Reduce generator output to keep panel meter at approx 3.   |
| 3.           | Set to 1400 kHz  | Center of 1400 kHz calibration mark on dial. | Front panel meter.<br>Adjust TC7, TC5, TC6 for max gain. Keep meter at approx 3. Repeat steps 2 and 3.  |

AM-FM TUNER PB2287-1

| Symbol   | Description   | Part No.   | Sug. Ret. | Symbol                 | Description                | Part No.        | Sug. Ret. |
|--|---|--|-----------|------------------------|----------------------------|-----------------|-----------|
| C1, C108A  | Ceramic, 10pF, ±0.5pF, 50V, N330  | CK2287-42333017  | .40       | C123                   | Electrolytic, 100uF, 16V   | CE2287-43001061 | .70       |
| C2   | Ceramic, 27pF, ±0.5pF, 50V  | CK2287-42333033  | .40       | CF1, 2, 3, 4, 5, 6     | Ceramic Filter, 10.7MHz    | ZK2287-61136001 | 1.35      |
| C3   | Ceramic, 8pF, ±0.5pF, 50V   | CK2287-42333015  | .40       | CF7                    | Ceramic Filter, 455kHz     | ZK2287-61131001 | 2.95      |
| C4, C10  | Ceramic, 1pF, ±0.25pF, 50V  | CK2287-42331001  | .35       | CP1                    | Printed Circuit            | EP2287-39050003 | .45       |
| C5, 8, 15, 16, 17, 18, 19, 20, 21, 22, 23, 24, 25, 26, 27, 29, 31, 31A, 45 | Ceramic, 0.01uF, +80-20%, 25V   | CK2287-42103004  | .35       | CP2, 10                | Printed Circuit            | EP2287-39050019 | .45       |
| C6   | Ceramic, 12pF, 5%, 50V  | CK2287-42333025  | .40       | CP3                    | Printed Circuit            | EP2287-39050024 | .45       |
| C7   | Ceramic, 5pF, ±0.5pF, 50V   | CK2287-42333012  | .40       | CP4, 6, 16, 18, 20     | Printed Circuit            | EP2287-39050015 | .45       |
| C9, 47   | Ceramic, 100pF, 5%, 50V   | CK2287-42333047  | .40       | CP5, 7, 9              | Printed Circuit            | EP2287-39051001 | .80       |
| C11  | Ceramic, 12pF, 10%, 50V, NPO  | CK2287-42332046  | .40       | CP8, 14                | Printed Circuit            | EP2287-39050012 | .45       |
| C12  | Ceramic, 20pF, 5%, 50V, NPO   | CK2287-42332028  | .40       | CP12                   | Printed Circuit            | EP2287-39053001 | 1.30      |
| C13  | Ceramic, 10pF, 1%, 50V  | CK2287-42336021  | .40       | CP13                   | Printed Circuit            | EP2287-39050027 | .45       |
| C14, 14A   | Ceramic, 1000pF, +80-20%, 25V   | CK2287-42103001  | .35       | CP15                   | Printed Circuit            | EP2287-39050011 | .45       |
| C28  | Ceramic, 10pF, ±0.5pF, 50V or 12pF, ±pF, 50V  | CK2287-42333017<br>CK2287-42333025   | .40       | CP17                   | Printed Circuit            | EP2287-39050029 | .40       |
| C30, 34, 39, 41, 42, 46, 116, 119  | Electrolytic, 2.2uF, 16V  | CE2287-43001054  | .50       | CP19                   | Printed Circuit            | EP2287-39050030 | .40       |
| C32  | Electrolytic, 10uF, 16V   | CE2287-43001057  | .50       | CP21, 22               | Printed Circuit            | EP2287-39052001 | 1.30      |
| C33, 36  | Polyethylene, 2200pF, ±10%, 50V   | CP2287-42749217  | .45       | D1, 2, 5, 6, 7, 8      | Diode SD-46                | TR2287-36002003 | .55       |
| C35, 38  | Polyethylene, 0.01uF, 10%, 50V  | CP2287-42749225  | .45       | D3, 4                  | Diode SD-46(1)             | TR2287-36002004 | .65       |
| C37  | Mylar, 0.047uF, 20%, 50V  | CY2287-42701023  | .50       | D9                     | Zener, Diode, RD11AM       | TR2287-36003026 | 1.70      |
| C40, 48  | Ceramic, 0.1uF, +80-20%, 12.5V  | CK2287-42104005  | .50       | IC1                    | Integrated Circuit LA1201  | TR2287-79905696 | 6.15      |
| C43, 44  | Mylar, 6800pF, 10%, 50V   | CY2287-42701118  | .40       | IC2                    | Integrated Circuit MC1305P | TR2287-37001004 | 13.15     |
| C102, 104, 105, 110, 110A, 111, 112, 113, 114, 115, 120, 121, 122          | Ceramic, 0.01uF, +80-20%, 25V   | CK2287-42103004  | .35       | L1                     | FM Antenna Coil            | LC2287-60723001 | 2.05      |
| C106, 107  | Mylar, 4700pF, 10%, 50V   | CY2287-42701117  | .40       | L2, 3                  | FM RF, Mixer Coil          | LC2287-60724001 | 1.30      |
| C108   | Ceramic, 18pF, 10%, 50V, N1500  | CK2287-42930009  | .50       | L4                     | FM Osc Coil                | LC2287-60782001 | 1.30      |
| C109   | Polyethylene, 430pF, 5%, 50V or 390pF, 5%, 50V  | CP2287-42749316<br>CP2287-42749315   | .45       | L5, 9                  | RF Choke, 2.2uH            | LC2287-61052009 | .55       |
| C109A  | Ceramic, 18pF, 5%, 50V or 27pF, 5%, 50V or 39pF, 5%, 50V or 56pF, 5%, 50V or 68pF, 5%, 50V or 82pF, 5%, 50V | CK2287-42333029<br>CK2287-42333033<br>CK2287-42333037<br>CK2287-42033041<br>CK2287-42033043<br>CK2287-42033045 | .40       | L7                     | AM RF Coil                 | LC2287-60700010 | 1.00      |
| C117   | Electrolytic, 10uF, 16V   | CE2287-43001057  | .50       | L8                     | AM Osc Coil                | LC2287-60779001 | 1.00      |
| C118   | Ceramic, 2200pF, +80-20%, 25V   | CK2287-42103002  | .35       | R1, 38, 101            | 220K                       | RF25DC224J      | .30       |
|  |   |  |           | R2, 44                 | 470                        | RF25DC471J      | .30       |
|  |   |  |           | R3, 32                 | 6.8K                       | RF25DC682J      | .30       |
|  |   |  |           | R4, 54                 | 12K                        | RF25DC123J      | .30       |
|  |   |  |           | R5, 36, 46             | 220                        | RF25DC221J      | .30       |
|  |   |  |           | R6, 42, 102            | 22K                        | RF25DC223J      | .30       |
|  |   |  |           | R7, 33, 123            | 1.2K                       | RF25DC122J      | .30       |
|  |   |  |           | R8                     | 56                         | RF25DC560J      | .30       |
|  |   |  |           | R9, 22, 103, 108, 121  | 1K                         | RF25DC102J      | .30       |
|  |   |  |           | R10, 37, 107           | 33K                        | RF25DC333J      | .30       |
|  |   |  |           | R11, 20, 23            | 33                         | RF25DC330J      | .30       |
|  |   |  |           | R12, 15, 330           | 330                        | RF25DC331J      | .30       |
|  |   |  |           | R13, 17, 124           | 820                        | RF25DC821J      | .30       |
|  |   |  |           | R14, 16, 104, 116, 119 | 56K                        | RF25DC563J      | .30       |
|  |   |  |           | R21                    | 8.2K                       | RF25DC822J      | .30       |
|  |   |  |           | R24                    | 18K                        | RF25DC183J      | .30       |
|  |   |  |           | R25, 26, 27            | 1.5K                       | RF25DC152J      | .30       |
|  |   |  |           | R28, 114               | 560                        | RF25DC561J      | .30       |
|  |   |  |           | R29, 47, 55, 122       | 4.7K                       | RF25DC472J      | .30       |

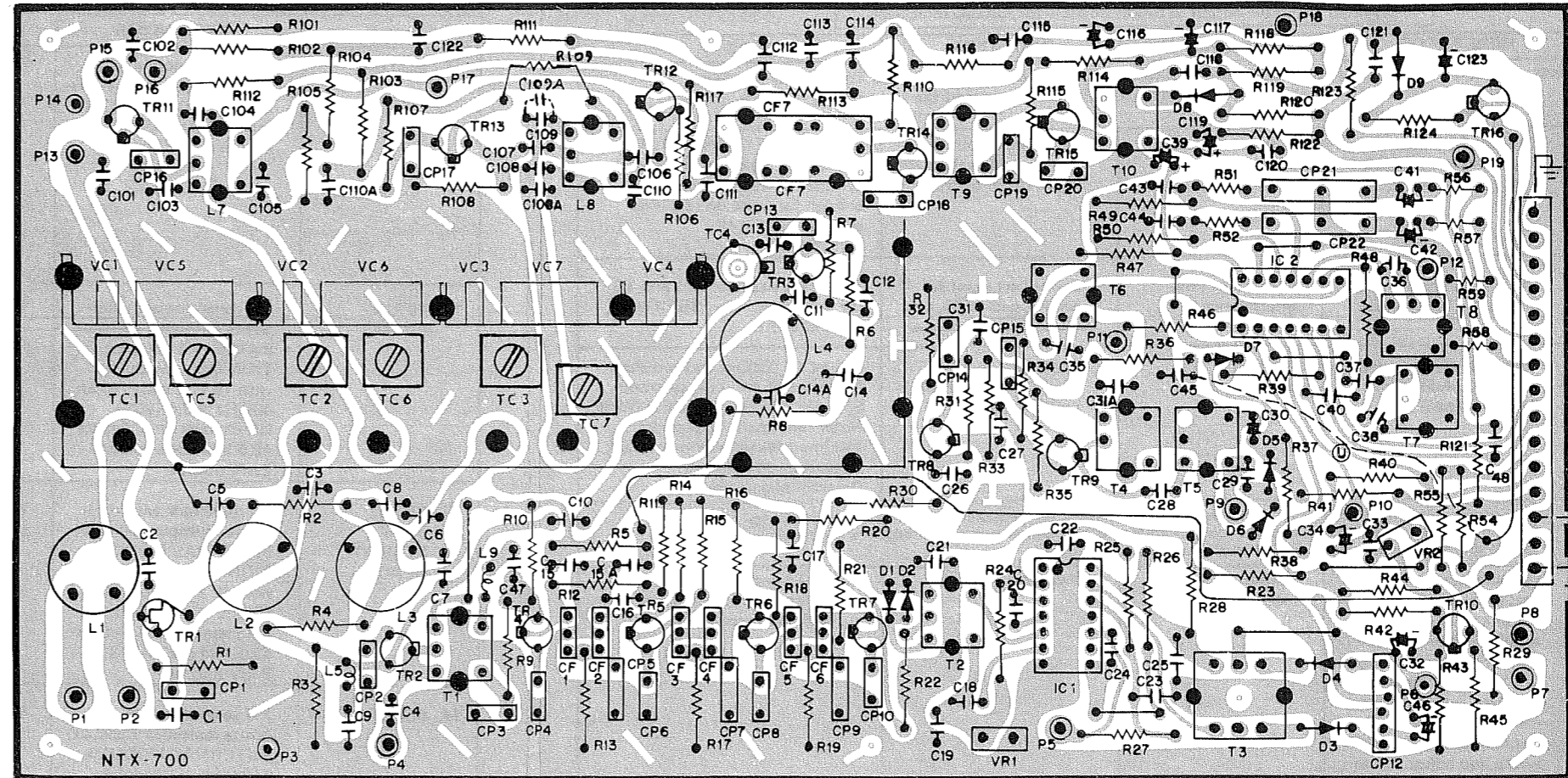

AL2287-111

(U) DENOTES WIRING ON UNDERSIDE OF BOARD

| Symbol         | Description                          | Part No.   | Sug. Ret. | Symbol                      | Description                            | Part No.        | Sug. Ret. |
|----------------|--------------------------------------|--|-----------|-----------------------------|--|-----------------|-----------|
| R30            | 2.7K or 2.2K or 3.3K or 3.9K or 4.7K | RF25DC272J<br>RF25DC222J<br>RF25DC332J<br>RF25DC392J<br>RF25DC472J | .30       | T9                          | IF Trans, 455kHz                       | LC2287-60812001 | 1.15      |
| R31, 35        | 27K                                  | RF25DC273J   | .30       | T10                         | IF Trans, 455kHz                       | LC2287-60802010 | 1.05      |
| R34            | 15K                                  | RF25DC153J   | .30       | TC1, 2, 3, 5, 6, 7          | Trimmer (Part of Tuning Gang Assembly) |                 |           |
| R39, 40        | 82K                                  | RF25DC823J   | .30       | TC4                         | Trimmer                                | CT2287-44316001 | .85       |
| R41            | 15K or 12K or 18K                    | RF25DC153J<br>RF25DC123J<br>RF25DC183J                             | .30       | TR1                         | FET 2SK19                              | TR2287-35120325 | 4.40      |
| R43, 49, 50    | 5.6K                                 | RF25DC562J   | .30       | TR2, 3                      | Transistor 2SC921K                     | TR2287-35046011 | 1.55      |
| R45            | 120                                  | RF25DC121J   | .30       | TR4, 5, 6, 8, 9, 11, 12, 14 | Transistor 2SC920Q                     | TR2287-35048617 | 1.10      |
| R51, 52        | 15K                                  | RF25DC153J   | .30       | TR7, 10, 13, 15             | Transistor 2SC920R                     | TR2287-35048618 | 1.10      |
| R56, 57        | 82K                                  | RF25DC823J   | .30       | TR16                        | Transistor 2SC815K                     | TR2287-35045311 | 1.50      |
| R58, 59, 117   | 100K                                 | RF25DC104J   | .30       | VC1, 2, 3, 4, 5, 6, 7       | Tuning Gang Assembly                   | CV2287-44019001 | 19.05     |
| R105           | 1M                                   | RF25DC105J   | .30       | VR1                         | Variable Resistor, 50K                 | RV2287-41950006 | .80       |
| R106, 109, 112 | 2.7K                                 | RF25DC272J   | .30       | VR2                         | Variable Resistor, 5K                  | RV2287-41950005 | .80       |
| R110           | 10K                                  | RF25DC103J   | .30       |                             | Connector, 15-pin, male                | HH20685-15      | 1.20      |
| R118           | 150K                                 | RF25DC154J   | .30       |                             | Insulator, Shield Plate B              | EM2287-18600491 | .40       |
| R120, 125      | 3.9K                                 | RF25DC392J   | .30       |                             | Shield Plate A (Component Side)        | AM2287-18501521 | .65       |
| T1, 2, 5       | IF Trans, 10.7MHz                    | ZZ2287-60828102  | 1.25      |                             | Shield Plate B (Underside)             | AM2287-18501841 | .75       |
| T3             | Ratio Det, 10.7MHz                   | ZZ2287-60830001  | 2.15      |                             |  |                 |           |
| T4             | IF Trans, 10.7MHz                    | ZZ2287-60828002  | 1.25      |                             |  |                 |           |
| T6, 7          | Coil, 19kHz                          | LC2287-61905003  | 1.80      |                             |  |                 |           |
| T8             | Coil, 38kHz                          | LC2287-61905004  | 1.80      |                             |  |                 |           |

MISCELLANEOUS

| Symbol | Description                                   | Part No.     | Sug. Ret. |
|--------|---|--------------|-----------|
| C50    | Ceramic, 1pF, ±0.25pF, 500V, P100             | C51188-1     | .35       |
| I1A,B  | Lampholder (Stereo Beacon, Meter)             | LM21420-3    | 2.00      |
| L9     | AM Antenna                                    | LA2287-114-1 | 2.60      |
| L10    | RF Choke, 3.3uH                               | LC21814-2    | .55       |
| M1     | Meter, Indicating                             | MC21613      | 7.10      |
| R61    | Composition, 270, 10%, 1/2W                   | RC20BF271K   | .30       |
| R62    | Composition, 330K, 10%, 1/2W                  | RC20BF334K   | .30       |
| S4     | Muting Off Switch (Part of 5 Switch assembly) | SP50200-52-1 | 6.10      |
| S101   | Selector Switch                               | SR2247-115   | 16.40     |
| S102   | Mode/Ext. Tape Monitor Switch                 | SR2247-116   | 9.20      |
| --     | Jack, FM Detector Out                         | J50465       | .40       |
| --     | Terminal Board, Antenna                       | ET51394      | 1.15      |

Note: Unless otherwise specified, all resistors are Carbon Film in ohms, 10%, 1/2W. K = Kilohms, M = Megohms



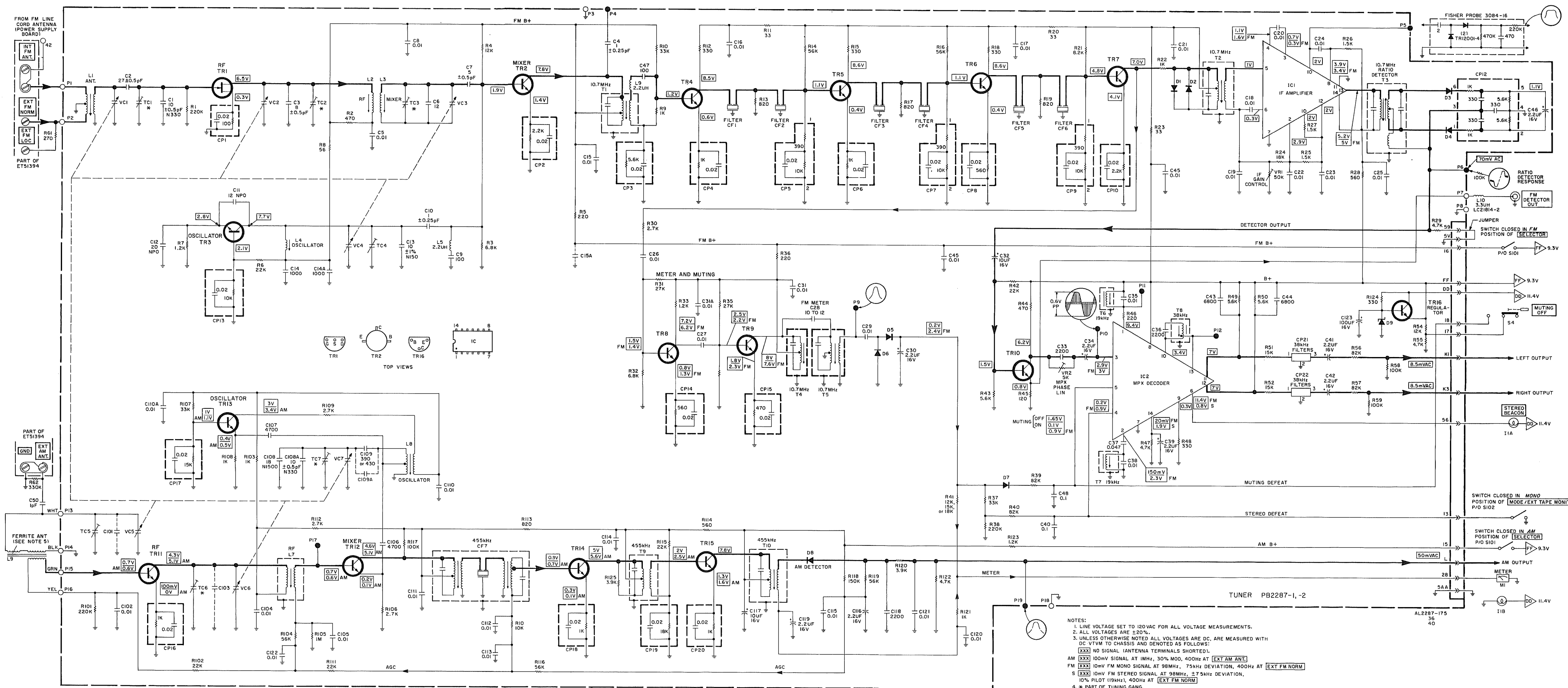

NOTES:  
 1. LINE VOLTAGE SET TO 120VAC FOR ALL VOLTAGE MEASUREMENTS.  
 2. ALL VOLTAGES ARE  $\pm 20\%$ .  
 3. UNLESS OTHERWISE NOTED ALL VOLTAGES ARE DC. ARE MEASURED WITH DC VTVM TO CHASSIS AND DENOTED AS FOLLOWS:  
 [XXX] NO SIGNAL (ANTENNA TERMINALS SHORTED).  
 AM [XXX] 100mV SIGNAL AT 1MHz, 30% MOD, 400Hz AT [EXT AM ANT].  
 FM [XXX] 10mV FM MONO SIGNAL AT 98MHz, 75kHz DEVIATION, 400Hz AT [EXT FM NORM].  
 S [XXX] 10mV FM STEREO SIGNAL AT 98MHz,  $\pm 75$ kHz DEVIATION, 10% PILOT (19kHz), 400Hz AT [EXT FM NORM].  
 4. \* PART OF TUNING GANG.  
 5. ANT LA2287-114-1 USED WITH PB2287-1, ANT LA2287-116-1 USED WITH PB2287-2.

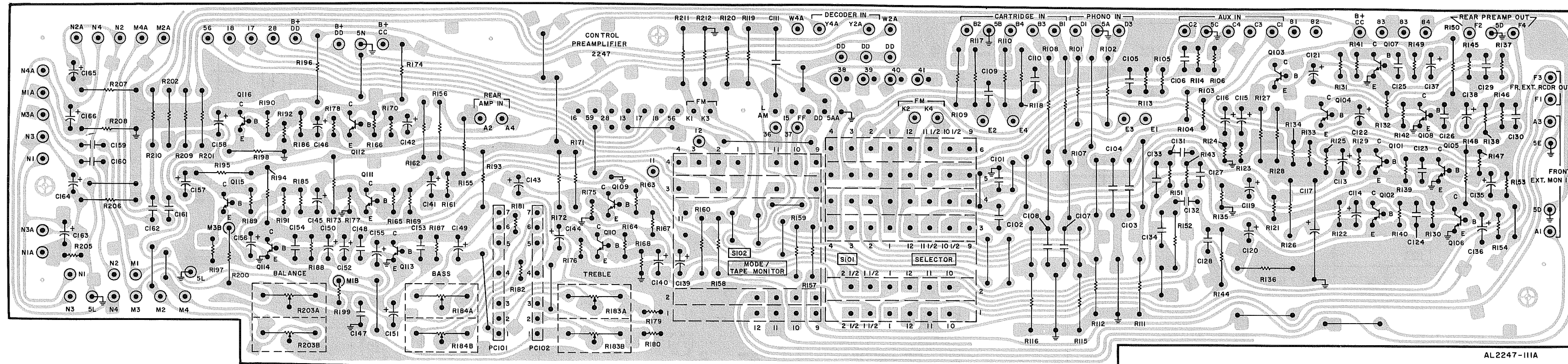

CONTROL-PREAMP PB2247-1

| Symbol                                  | Description                       | Part No.           | Sug. Ret. |
|---|-----------------------------------|--------------------|-----------|
| C101, 102                               | Ceramic, 470pF, 10%, 500V         | C50B651-13         | .35       |
| C103, 104, 107, 108                     | Ceramic, 330pF, 10%, 500V         | C51B189-1          | .35       |
| C105, 106, 109, 110                     | Ceramic, 330pF, 10%, 500V         | C50B651-1          | .30       |
| C111                                    | Mylar, 0.047uF, 10%, 250V         | C50B574-5          | .50       |
| C113, 114, 115, 116                     | Tantalum, 0.68uF, 20%, 35V        | CL22306-2          | .75       |
| C117                                    | Electrolytic, 220uF, 6.3V         | CE22324-4          | .70       |
| C119, 120, 121, 122                     | Electrolytic, 10uF, 63V           | CE22326-4          | .35       |
| C123, 124, 125, 126                     | Ceramic, 5pF, 5%, 500V, NPO       | C50B652-21         | .35       |
| C127, 128, 129, 130                     | Ceramic, 120pF, 10%, 500V         | C50B651-16         | .30       |
| C131, 132                               | Ceramic, 5000pF, 20%, 500V        | C50B567-2          | .30       |
| C133, 134                               | Ceramic, 1500pF, 10%, 1000V       | C50B576-4          | .45       |
| C135, 136, 137, 138, 157, 158           | Tantalum, 2.7uF, 20%, 35V         | CL22305-4          | .45       |
| C139, 140, 141, 142                     | Tantalum, 0.33uF, 20%, 35V        | CL22305-9          | .80       |
| C143, 144, 145, 146, 151, 152           | Tantalum, 1uF, 20%, 35V           | CL22305-3          | .80       |
| C147, 148                               | Ceramic, 820pF, 10%, 500V         | C50B651-6          | .30       |
| C149, 150, 155, 156                     | Tantalum, 4uF, 20%, 35V           | C22305-14          | .90       |
| C153, 154                               | Ceramic, 47pF, 10%, 500V, N330    | C50B652-19         | .30       |
| C159, 160, 161, 162                     | Ceramic, 680pF, 10%, 500V         | C50B651-2          | .30       |
| C163, 164, 165, 166                     | Mylar, 0.22uF, 10%, 250V          | C50B575-2          | .60       |
| PC101, 102                              | Encapsulated Tone Control Network | PC50B187-57        | 1.60      |
| Q101, 102, 103, 104                     | Transistor                        | TR02020-2          | .55       |
| Q105, 106, 107, 108, 109, 110, 111, 112 | Transistor                        | TR01037 or TR01015 | 1.00      |
| Q113, 114, 115, 116                     | Transistor                        | TRBC147B           | .60       |

| Symbol   | Description | Part No.  | Sug. Ret. |
|--|-------------|-----------|-----------|
| R101, 102  | 1.5K        | R33DC152J | .30       |
| R103, 104, 105, 106, 134                               | 100K        | R33DC104J | .30       |
| R107, 108, 109, 110, 119, 167, 168, 161, 162, 185, 186 | 27K         | R33DC273J | .30       |
| R111, 112, 113, 114, 120, 171, 172, 173, 174, 195, 196 | 5.6K        | R33DC562J | .30       |
| R115, 116, 117, 118, 121, 122, 129, 130, 131, 132      | 6.8K        | R33DC682J | .30       |
| R121, 122, 129, 130, 131, 132                          | 82K         | R33DC823J | .30       |
| R123, 124, 125, 126, 127, 128                          | 120K        | R33DC124J | .30       |
| R133, 147, 148, 199, 200, 201, 202, 209, 210           | 10K         | R33DC103J | .30       |
| R135, 136, 137, 138, 177, 178, 197, 198                | 820         | R33DC821J | .30       |
| R139, 140, 153, 154, 179, 180                          | 1M          | R33DC105J | .30       |
| R141, 142, 143, 144, 145, 146                          | 560K        | R33DC564J | .30       |
| R143, 144, 145, 146                                    | 18K         | R33DC183J | .30       |
| R149, 150, 193, 194                                    | 4.7K        | R33DC472J | .30       |
| R151, 152, 159, 160                                    | 56K         | R33DC563J | .30       |
| R155, 156, 157, 158                                    | 22K         | R33DC223J | .30       |

| Symbol              | Description  | Part No.    | Sug. Ret. |
|---------------------|--|-------------|-----------|
| R163, 164           | 270K   | R33DC274J   | .30       |
| R165, 166, 189, 190 | 180K   | R33DC184J   | .30       |
| R169, 170, 191, 192 | 39K  | R33DC393J   | .30       |
| R175, 176           | 120  | R33DC121J   | .30       |
| R181, 182           | 330K   | R33DC334J   | .30       |
| R183A, B, 184A, B   | Potentiometer, Dual-Bass, Treble, 200K                 | RP50160-283 | 3.00      |
| R187, 188           | 1.2M   | R33DC125J   | .30       |
| R203A, B            | Potentiometer, Dual-Balance                            | RP50160-284 | 2.80      |
| R205, 206, 207, 208 | 2.7K   | R33DC272J   | .30       |
| S101                | Selector Switch  | SR2247-115  | 16.40     |
| S102                | Mode/Ext Tape Monitor Switch Connector, 15-pin, female | SR2247-116  | 9.20      |
|                     |  | H1120683-15 | .65       |

2+2 CH DECODER PB2289-2

| Symbol              | Description                     | Part No.   | Sug. Ret. |
|---------------------|---------------------------------|------------|-----------|
| C271, 272           | Mylar, 0.01uF, 5%, 100V         | C50B574-1  | .45       |
| C273                | Ceramic, 5000pF, 20%, 500V      | C50B567-2  | .30       |
| C275, 276           | Ceramic, 180pF, 10%, 500V       | C50B651-14 | .50       |
| C277, 278, 279, 280 | Sintered Alum., 0.33uF, 20% 25V | CS22340-3  | .50       |
| C281, 282           | Sintered Alum., 4.7uF, 20% 25V  | CS22340-6  | .70       |
| C283                | Electrolytic, 100uF, 25V        | CE22326-1A | .40       |
| Q271, 272, 273, 274 | Transistor BC239C               | TR01014    | .50       |
| R271, 272           | Composition, 180K, 5%, 1/4W     | RC07BF184J | .30       |
| R273, 274           | Composition, 12K, 5%, 1/8W      | R12DC123J  | .30       |
| R275, 276           | Composition, 8.2K, 5%, 1/4W     | RC07BF822J | .30       |
| R277, 278           | Composition, 5.6K, 5%, 1/8W     | R12DC562J  | .30       |
| R279, 280           | Composition, 820, 5%, 1/4W      | RC07BF821J | .30       |
| R281                | Composition, 3.3K, 5%, 1/4W     | RC07BF332J | .30       |
| R283, 284           | Composition, 100K, 5%, 1/4W     | RC07BF104J | .30       |
| R285, 286           | Composition, 3.9M, 5%, 1/4W     | RC07BF395J | .30       |
| R287, 288           | Composition, 4.7K, 5%, 1/4W     | RC07BF472J | .30       |
| R289, 290           | Composition, 680, 5%, 1/4W      | RC07BF681J | .30       |
| R291                | Composition, 2.2K, 5%, 1/4W     | RC07BF222J | .30       |

VOLUME PB2284-1

| Symbol            | Description                    | Part No.    | Sug. Ret. |
|-------------------|--------------------------------|-------------|-----------|
| R298A, B, 299A, B | Potentiometer, Dual Slide, 50K | RP50160-278 | 5.75      |

MISCELLANEOUS

| Symbol | Description  | Part No.     | Sug. Ret. |
|--------|--|--------------|-----------|
|        | Jack, Ext Recorder Out Front, Rear                       | JK20627-5    | 1.10      |
|        | Jack Strip, Input-Output                                 | JK20691      | 3.00      |
|        | Jumper, Input-Output                                     | AS836-120    | .10       |
|        | Lamp Assembly, Receiver Mode (4 lamp)                    | AS21432-1    | 7.55      |
| C284   | Ceramic, 3800pF, 10%, 500V                               | C51B189-17   | .40       |
| S4, S5 | Switch, Muting Off, Loudness (Part of 5 switch assembly) | SP50200-52-1 | 6.65      |
| S6, S7 | Switch, 2+2 Decoder (2 switch assembly)                  | SP50200-55   | 3.20      |

NOTE: Unless otherwise specified, all resistors are Carbon Film in ohms, 5%, 1/3 Watt. K = Kilohms, M = Megohms

2+2 DECODER 2289-2

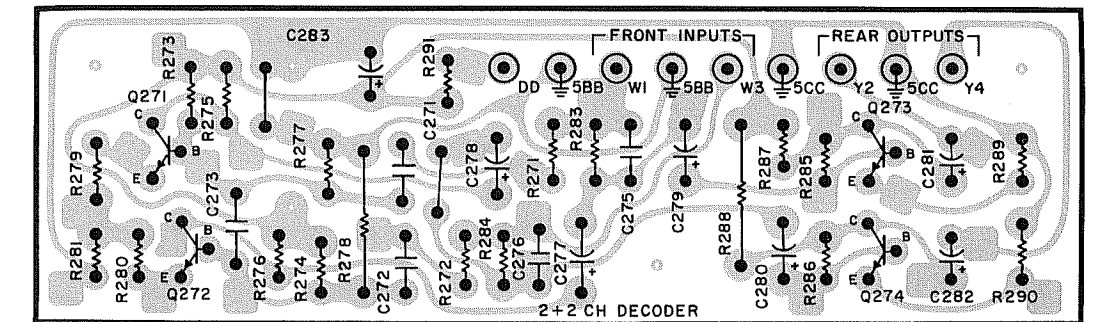

AL2289-111

VOLUME 2284-1

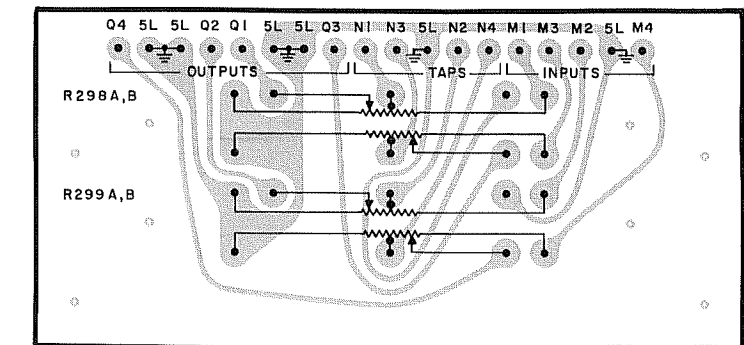

AL2284-111

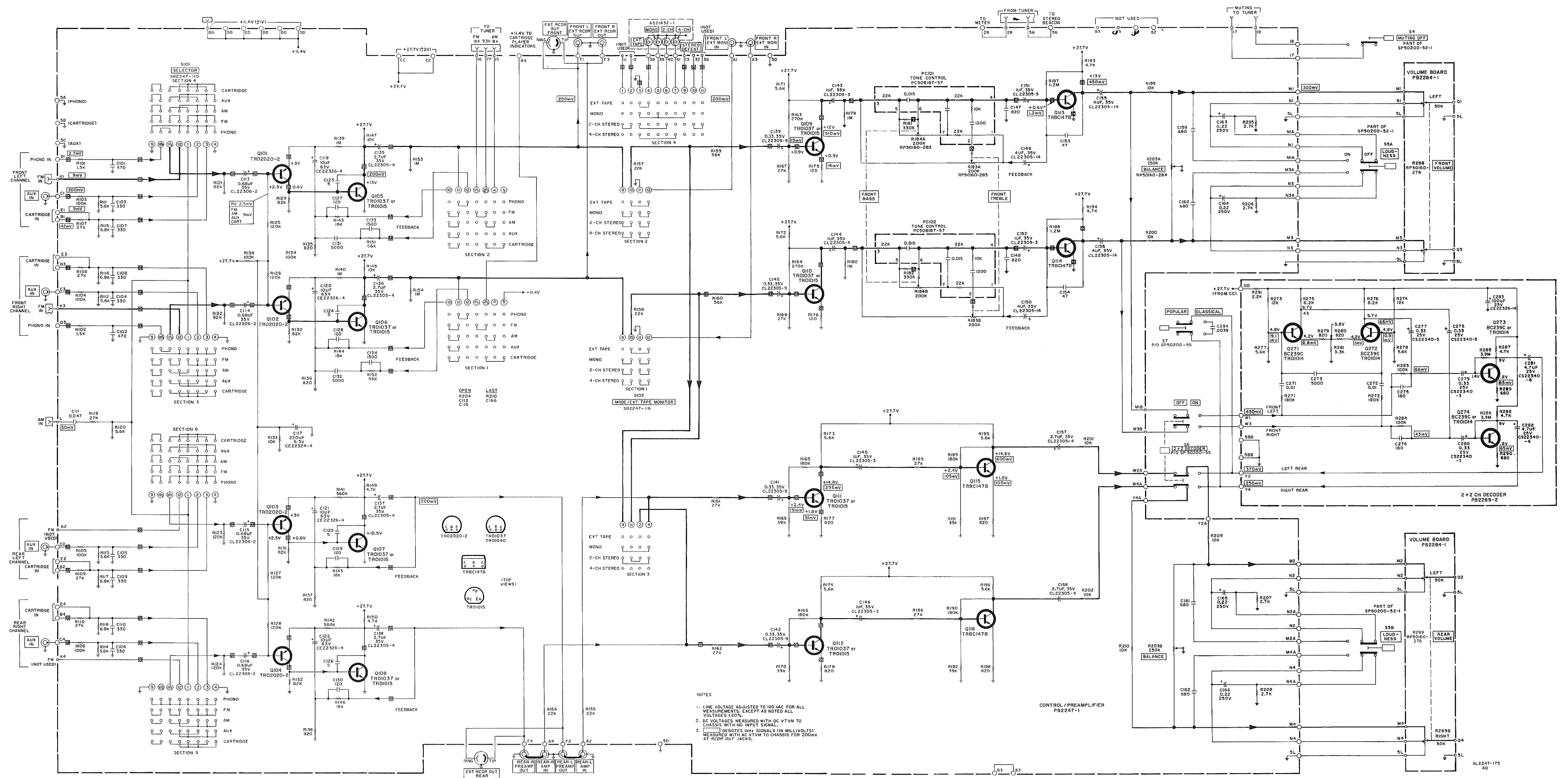

CONTROL/PREAMPLIFIER PB2247-1

**POWER AMPLIFIER PB2291-1**

| Symbol      | Description                    | Part No.      | Sug. Ret. |
|-------------|--------------------------------|---------------|-----------|
| C801, 802   | Tantalum, 1uF, 35V             | CL22305-3     | .80       |
| C803, 804   | Ceramic, 47pF, 10%, 500V, N330 | C50B652-19    | .30       |
| C805, 806   | Electrolytic, 22uF, 35V        | CE22326-6     | .40       |
| C807, 808   | Ceramic, 330pF, 10%, 500V      | C50B651-1     | .30       |
| C809        | Electrolytic, 47uF, 35V        | CE22326-15    | .70       |
| C810, 823,  | Ceramic, 0.1uF, 35%, 100V      | C51163-1      | .80       |
| C810, 823,  | Ceramic, 0.1uF, 35%, 100V      | C51163-1      | .80       |
| 824         |                                |               |           |
| C811, 812   | Electrolytic, 100uF, 16V       | CE22326-12    | .40       |
| C811, 812   | Electrolytic, 100uF, 16V       | CE22326-12    | .40       |
| C813, 814   | Ceramic, 150pF, 10%, 500V      | C50B651-9     | .30       |
| C815        | Electrolytic, 22uF, 63V        | CE22326-17    | .40       |
| C817, 818,  | Ceramic, 220pF, 10%, 500V      | C50651-15     | .30       |
| 819, 820    |                                |               |           |
| C821, 822   | Electrolytic, 1600uF, 50V      | CE22324-47    | 2.15      |
| CR801, 802  | Silicon Stabistor              | SIT51B096-12  | 1.00      |
| CR803, 804, | Silicon Stabistor              | SIT51B096-5   | .95       |
| 805, 806    |                                |               |           |
| Q801, 802   | Transistor                     | TR02051-1     | .75       |
| Q803, 804   | Transistor                     | TR01014       | .50       |
| Q805, 806   | Transistor                     | TR01053-1     | 1.45      |
| Q807, 808   | Transistor                     | TR01062-1     | 1.90      |
| Q809, 810   | Transistor                     | TR02062-1     | 2.00      |
| Q811, 812   | Transistor                     | TR02057-3     | 3.70      |
| Q813, 814   | Transistor                     | TR01057-3     | 3.40      |
| R801, 802   | 180K                           | R33DC184J     | .30       |
| R803, 804   | 68K                            | R33DC683J     | .30       |
| R805, 806,  | 3.9K                           | R33DC392J     | .30       |
| 807, 808    |                                |               |           |
| R809, 810,  | 100                            | R33DC101J     | .30       |
| 819, 820    |                                |               |           |
| R811        | 150K                           | R33DC154J     | .30       |
| R812        | 470                            | R33DC471J     | .30       |
| R813, 814   | 22K                            | R33DC223J     | .30       |
| R815, 816   | 33                             | R33DC330J     | .30       |
| R817, 818   | 1.2K                           | R33DC122J     | .30       |
| R821, 822,  | 1.5K                           | R33DC152J     | .30       |
| 823, 824    |                                |               |           |
| R825, 826   | Variable, 100                  | R50B150-19-11 | .70       |
| R827, 828,  | Composition, 120, 5%, 1/2W,    | RC20BF121J    | .30       |
| 829, 830    |                                |               |           |
| R831, 832   | Wirewound, 0.33, 5%, 5W        | RW5WR33J      | .50       |
| R833, 834   | Wirewound, 0.39, 5%, 5W        | RW5WR39J      | .50       |
| R835, 836   | Composition, 10, 5%, 1/2W      | RC20BF100J    | .30       |

NOTE: Unless otherwise specified, all resistors are Carbon Film in ohms, 5%, 1/3 Watt. K = Kilohms, M = Megohms

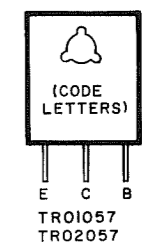
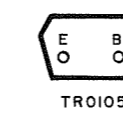
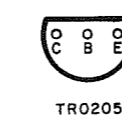
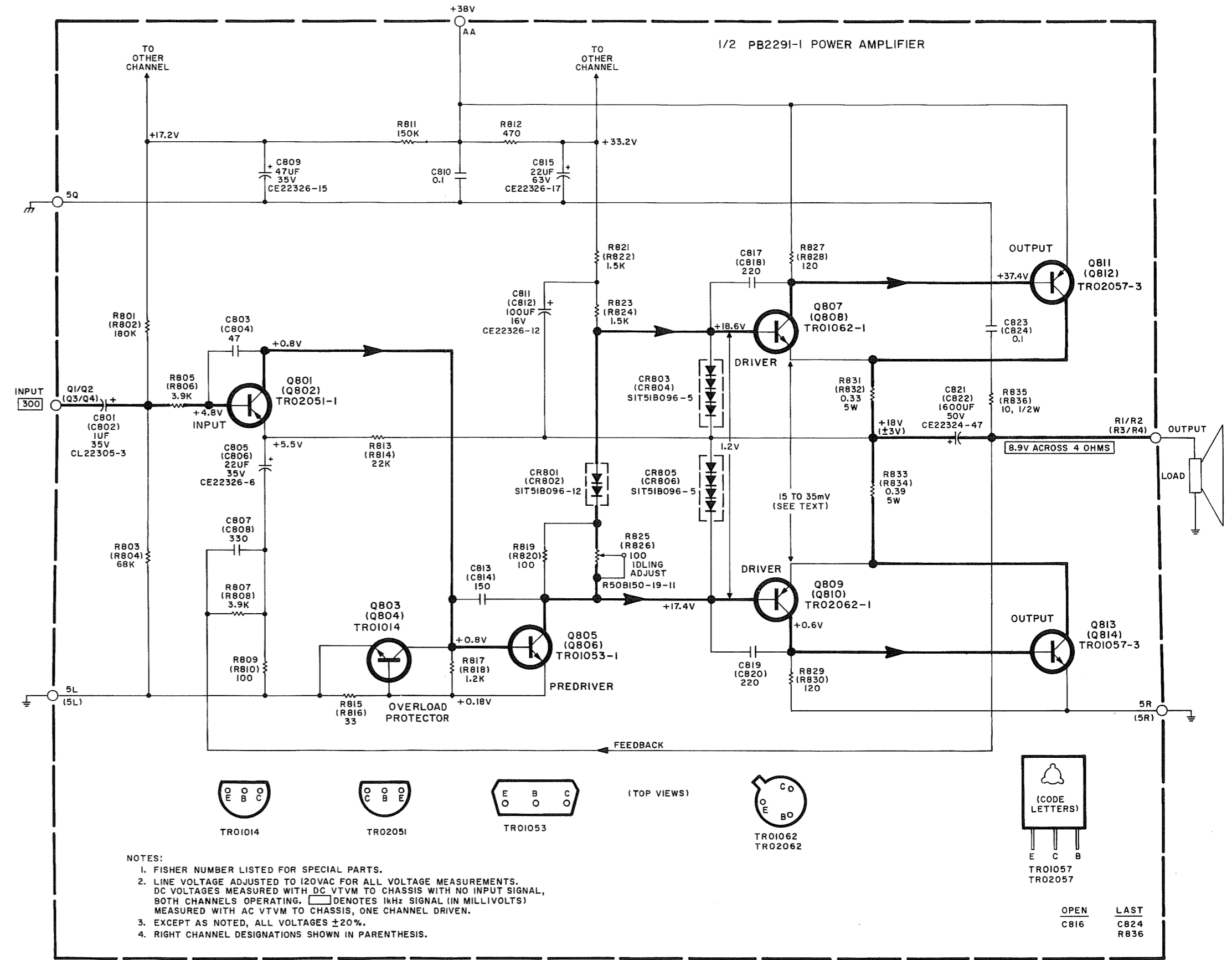

- NOTES:
1. FISHER NUMBER LISTED FOR SPECIAL PARTS.
  2. LINE VOLTAGE ADJUSTED TO 120VAC FOR ALL VOLTAGE MEASUREMENTS. DC VOLTAGES MEASURED WITH DC VTVM TO CHASSIS WITH NO INPUT SIGNAL, BOTH CHANNELS OPERATING. □ DENOTES 1kHz SIGNAL (IN MILLIVOLTS) MEASURED WITH AC VTVM TO CHASSIS, ONE CHANNEL DRIVEN.
  3. EXCEPT AS NOTED, ALL VOLTAGES ±20%.
  4. RIGHT CHANNEL DESIGNATIONS SHOWN IN PARENTHESIS.

OPEN LAST  
C816 C824  
R836



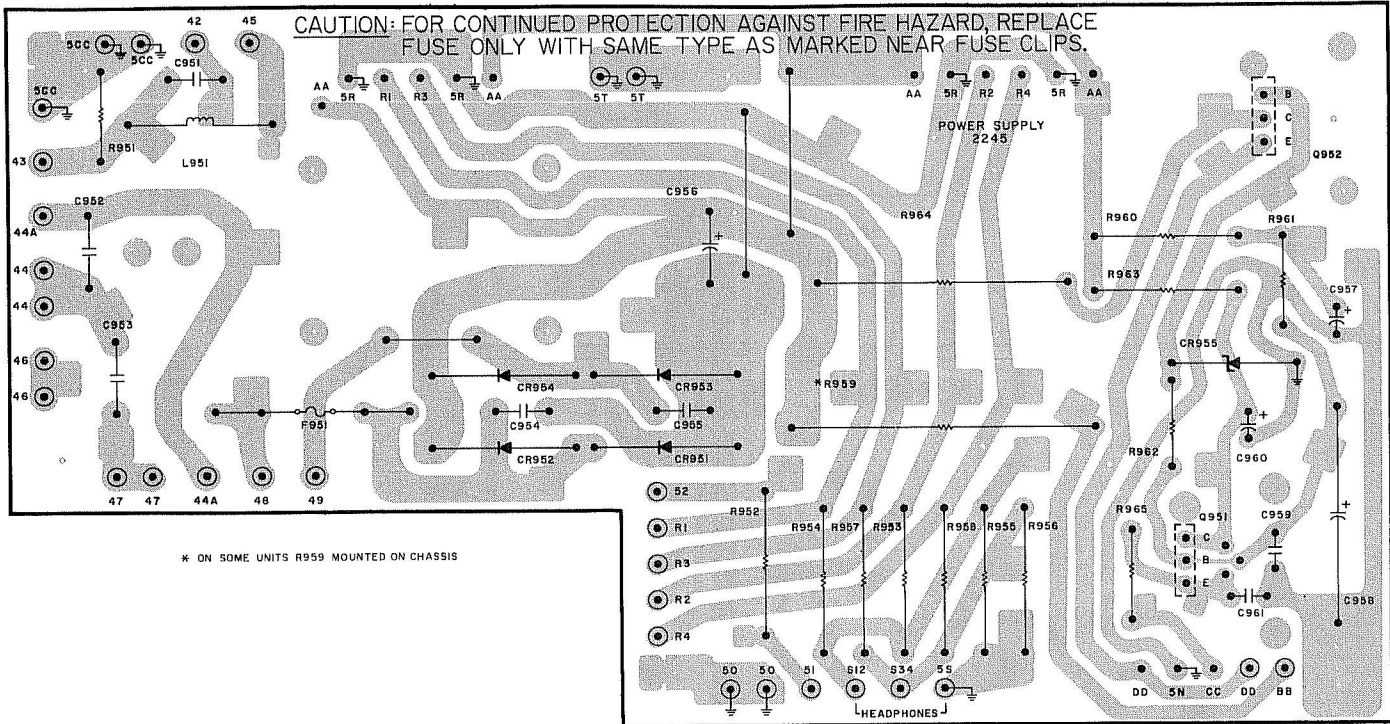

AL2245-111A

POWER SUPPLY PB2245-1, -2

| Symbol               | Description                                  | Part No.     | Sug. Ret. |
|----------------------|--|--------------|-----------|
| C951                 | Ceramic, 330pF, +80-20%, 1400V               | C50404-3     | .45       |
| *C951                | Ceramic, 330pF, 20%, 400VAC                  | C51164-1     | .90       |
| C952, 953            | Ceramic, 0.01uF, +80-20%, 150V               | C50404-4     | .50       |
| C954, 955            | Ceramic, 0.02uF, 20%, 500V                   | C50B567-3    | .35       |
| C956                 | Electrolytic, 3500uF, 50V                    | CE22323-20   | 4.15      |
| C957, 960            | Electrolytic, 100uF, 50V                     | CE22326-20   | .75       |
| C958                 | Electrolytic, 220uF, 63V                     | CE22324-32   | 1.25      |
| C959, 961            | Ceramic, 0.01uF, +80-20%, 100V               | C50B570-1    | .40       |
| CR951, 952, 953, 954 | Silicon Diode                                | SID51C169-1  | .75       |
| CR955                | Zener Regulator 12V, 5%, 1W                  | TR14002-6    | 1.05      |
| F951                 | Fuse, Slo-Blo, 6 1/4A, 125V                  | FL51313-21   | .70       |
| L951                 | RF Choke, 0.55uH                             | LC21818      | .60       |
| Q951                 | Transistor                                   | TR01053-1    | 1.45      |
| Q952                 | Transistor                                   | TR01057-1    | 2.75      |
| R951                 | Composition, 820K, 10%, 1/2W                 | RC20BF824K   | .30       |
| R952                 | Wirewound, 0.51, 5%, 2W                      | RW200WR51J   | .60       |
| R953, 954, 957, 958  | Wirewound, 220, 5%, 2W                       | RW200 W221J  | .45       |
| R955, 956, 963       | Wirewound, 100, 5%, 2W                       | RW200W101J   | .45       |
| R959                 | Wirewound, 15, 5%, 15W                       | RW15W150J    | .60       |
| R960, 961            | Carbon Film, 330, 5%, 1/3 W                  | R33DC331J    | .30       |
| R962                 | Composition, 1.2K, 5%, 1/2W                  | RC20BF122J   | .30       |
| R964                 | Wirewound, 68, 5%, 7W                        | RW7W680J     | .50       |
| R965                 | Composition, 10, 5%, 1/2W                    | RC20BF100J   | .35       |
| F1                   | Fuse, Slo-Blo, 3.2A, 125V                    | FL51313-6    | .65       |
| *F1                  | Fuse, Slo-Blo, 3.5A, 120V                    | F51B247-21   | .60       |
| *F1                  | Fuse, Slo-Blo, 1.6A, 250V                    | F51B247-17   | .60       |
| S1                   | Switch, Power On (Part of 5-switch assembly) | SP50200-52-1 | 6.65      |
|                      | *Switch, Voltage Selector                    | SR51304-1    | 1.65      |
|                      | AC Outlet, 250W                              | JK20665      | .65       |
|                      | Connector, Changer, 4-terminal               | J50375-4     | .45       |
|                      | Fuseholder                                   | X51B080      | 1.35      |
|                      | Line Cord                                    | W50023-1     | 1.25      |
|                      | Transformer, Power                           | TD4058-115   | 19.20     |
|                      | *Transformer, Power                          | TD4058-215   | 29.55     |

\*Used in PB2245-2 only

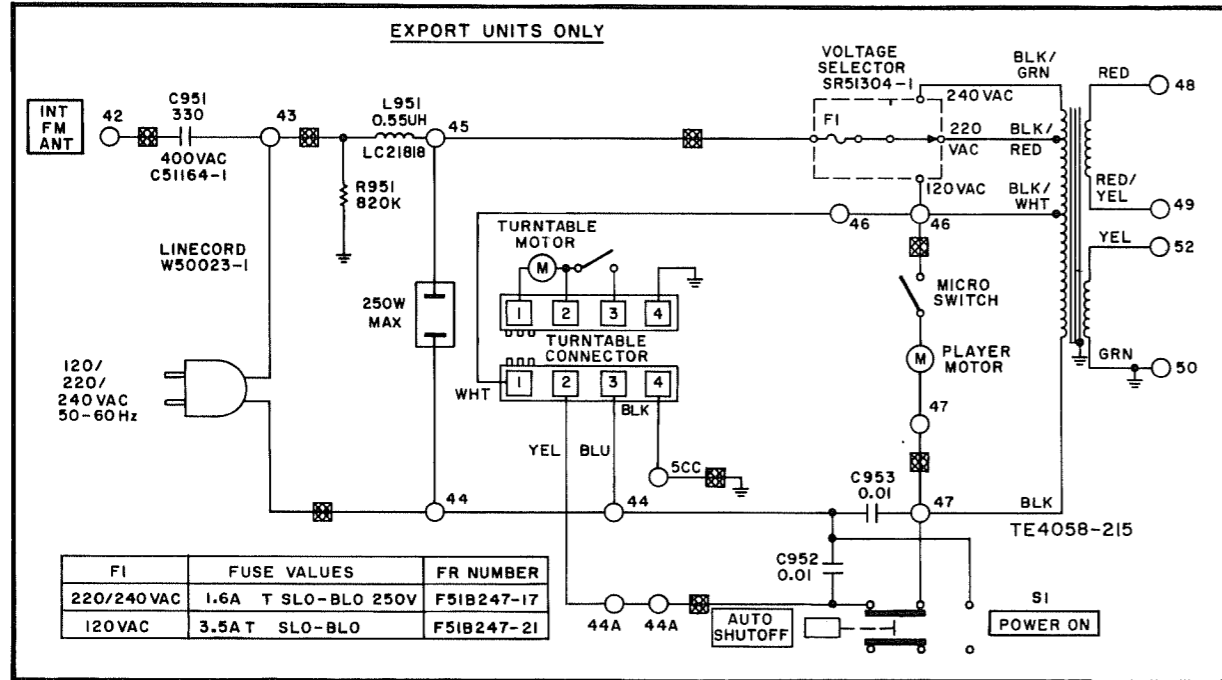

NOTES:

1. LINE VOLTAGE SET TO 120 VAC FOR ALL DC VOLTAGE MEASUREMENTS.
2. EXCEPT AS NOTED, ALL VOLTAGES  $\pm 20\%$ .
3. DC VOLTAGES MEASURED WITH DC VTVM TO CHASSIS WITH NO INPUT SIGNALS, *SELECTOR* IN *AUX* POSITION.
4. \*C960 NOT USED IN ALL UNITS.
5. \*\*ON SOME UNITS R959 MOUNTED ON CHASSIS.
6. † BB MOMENTARILY DROPS TO 12V WHEN PROGRAM SOLENOID IS ACTUATED.

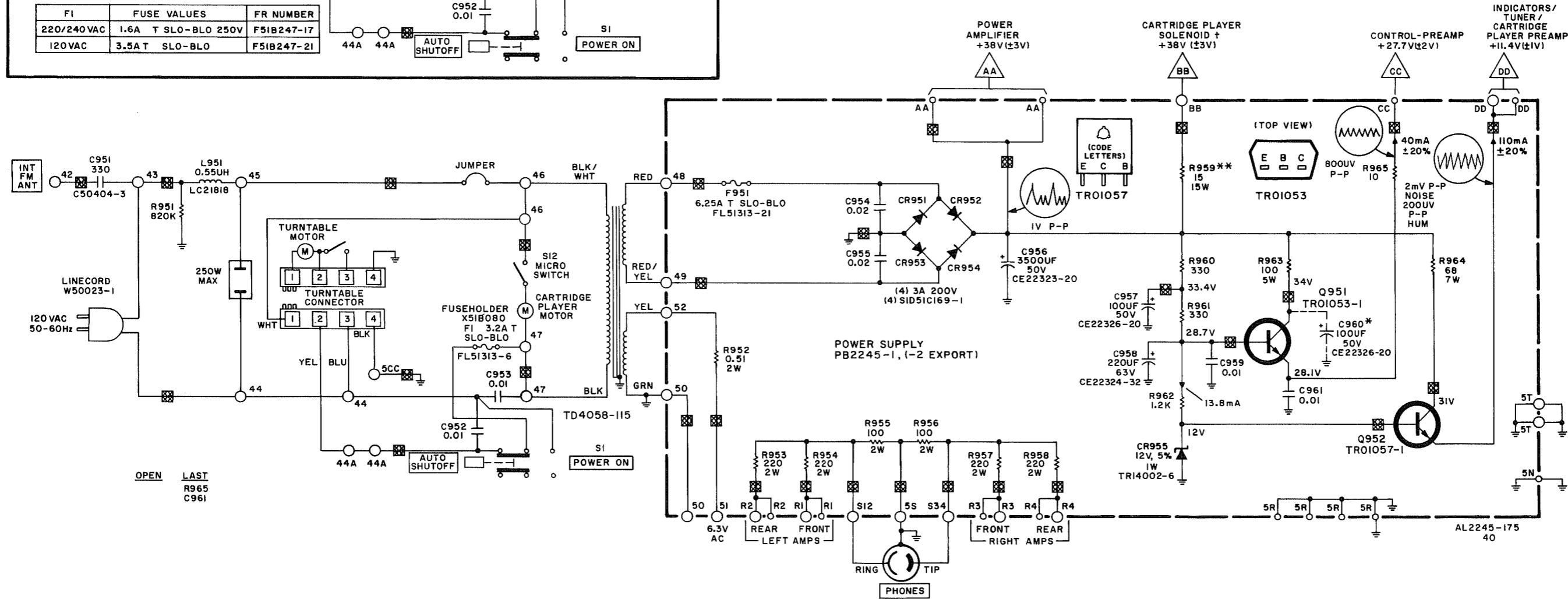

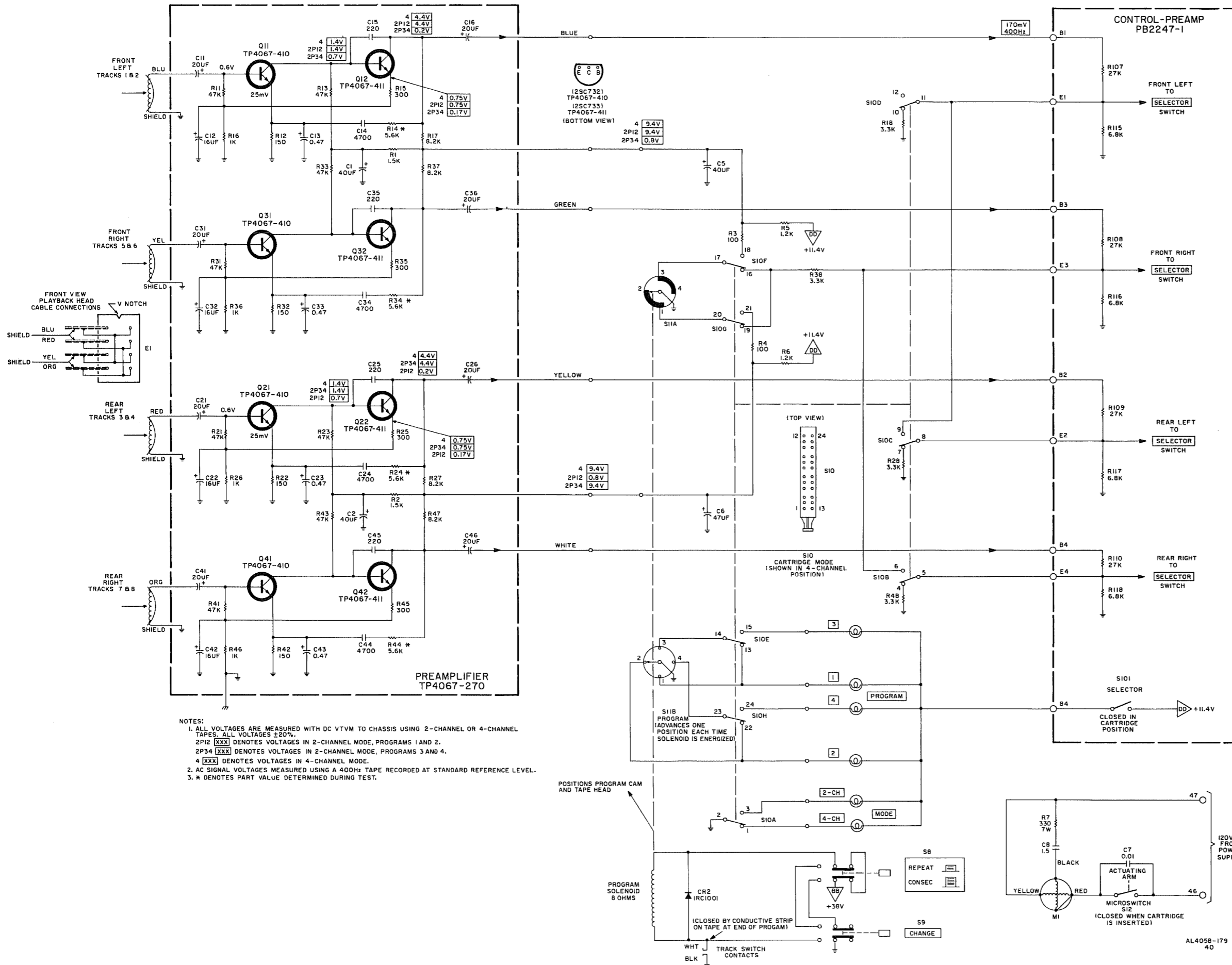

**FUNCTIONAL OPERATION**

Insertion of a tape cartridge automatically closes microswitch S12, which supplies AC power to the motor. When a 4-channel cartridge is inserted, all four channels of the preamplifier are activated, equalizing and amplifying signals to the output terminals.

In 4-CH operation, the 8-track cartridge contains two programs.

- |            |                     |
|------------|---------------------|
| Program 1: |                     |
| Track 1    | Front left channel  |
| Track 5    | Front right channel |
| Track 3    | Rear left channel   |
| Track 7    | Rear right channel  |
| Program 2: |                     |
| Track 2    | Front left channel  |
| Track 6    | Front right channel |
| Track 4    | Rear left channel   |
| Track 8    | Rear right channel  |

There are two mechanical positions for the tape head, up or down. Pressing CHANGE pushbutton S9 actuates the program solenoid. The solenoid moves a pawl which engages and rotates the program cam. A transfer pin which rides on the cam surface causes the tape head to alternately move up for Program 1 or down for Program 2. The program solenoid is also actuated by a conductive strip placed on the tape at the end of the program.

With REPEAT - CONSEC switch S8 in the CONSEC position, the program in progress continues to play until the conductive strip contacts the track switch, shifting the tape head to play the next program automatically. In the REPEAT position, the B+ to the program solenoid is opened. This prevents actuation of the solenoid and shifting of the tape head when the conductive strip contacts the track switch. Thus the same program is repeated. Pressing CHANGE pushbutton S9 actuates the program solenoid in either CONSEC or REPEAT. In REPEAT, B+ to the solenoid is fed through contacts of the CHANGE switch.

There are four separate programs contained in a 2-channel cartridge.

- |            |               |
|------------|---------------|
| Program 1: |               |
| Track 1    | Left channel  |
| Track 5    | Right channel |
| Program 2: |               |
| Track 2    | Left channel  |
| Track 6    | Right channel |
| Program 3: |               |
| Track 3    | Left channel  |
| Track 7    | Right channel |
| Program 4: |               |
| Track 4    | Left channel  |
| Track 8    | Right channel |

When a 2-channel cartridge is inserted, it engages the actuating arm of cartridge mode microswitch S10, and it is actuated. (A slot in the 4-channel cartridges bypasses the engaging arm of the microswitch.) To prevent playing two independent stereo (2-channel) programs simultaneously (one program on tracks 1 and 5, and the other on tracks 3 and 7), the B+ feeding the front or rear preamplifier channels is turned off, making only one pair of channels active at a time. For programs 1 and 2 the front channels of the preamplifier are active, for programs 3 and 4 the rear channels are active. Program switch S11B does the switching. The program switch is a rotary type operated by the program solenoid in conjunction with the cam. In addition, the left front and left rear channels are paralleled in 2-channel mode and the right front and left rear channels are similarly paralleled. Cartridge mode switch S10 makes the parallel connections.

When active channels are paralleled with inactive channels, a normal 6dB drop in the output level results from paralleling source impedances. In 4-channel operation, resistors R18, R28, R38, and R48 are switched in across the input resistors of the control-preamp (R115, R116, R117, and R118). The parallel resistors reduce the output level approximately 6dB to maintain equal output levels in the 2- and 4-channel modes.

The appropriate CARTRIDGE MODE and PROGRAM lamps are switched on through S10 and S11. With a 4-channel cartridge, switch connections are such that only PROGRAM lamps 1 and 2 can light.



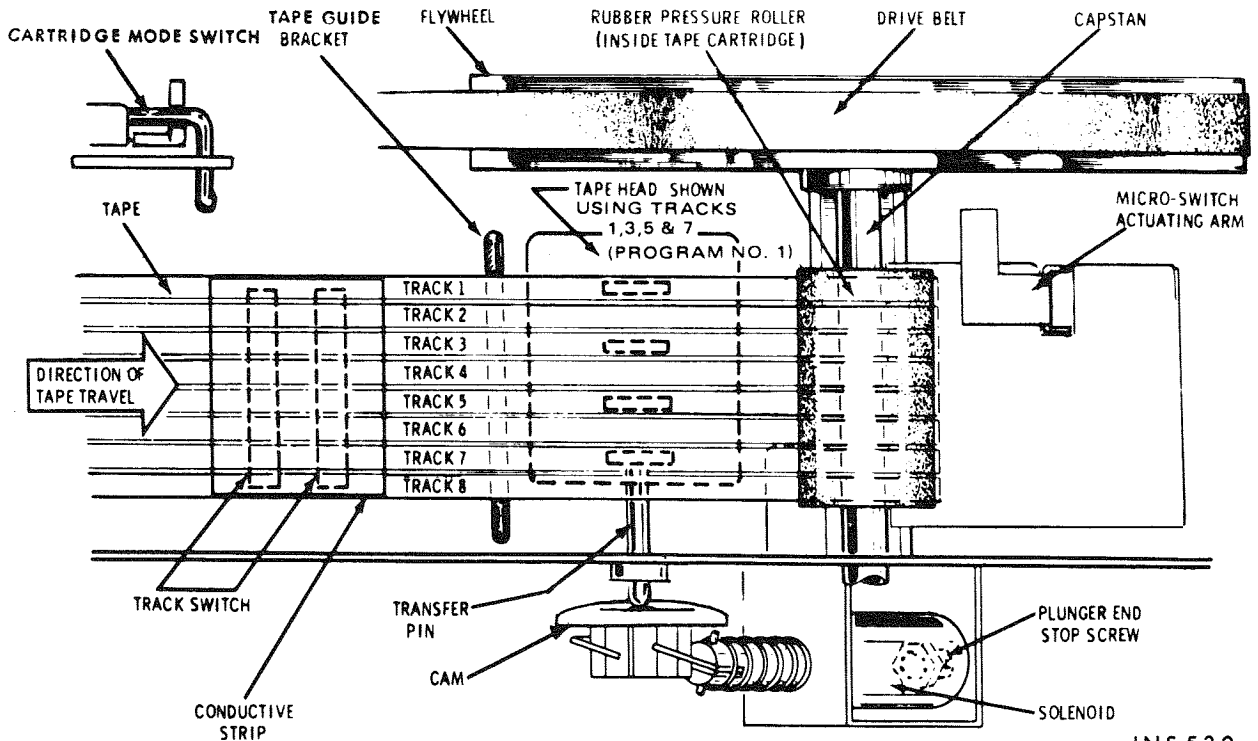

INS 530

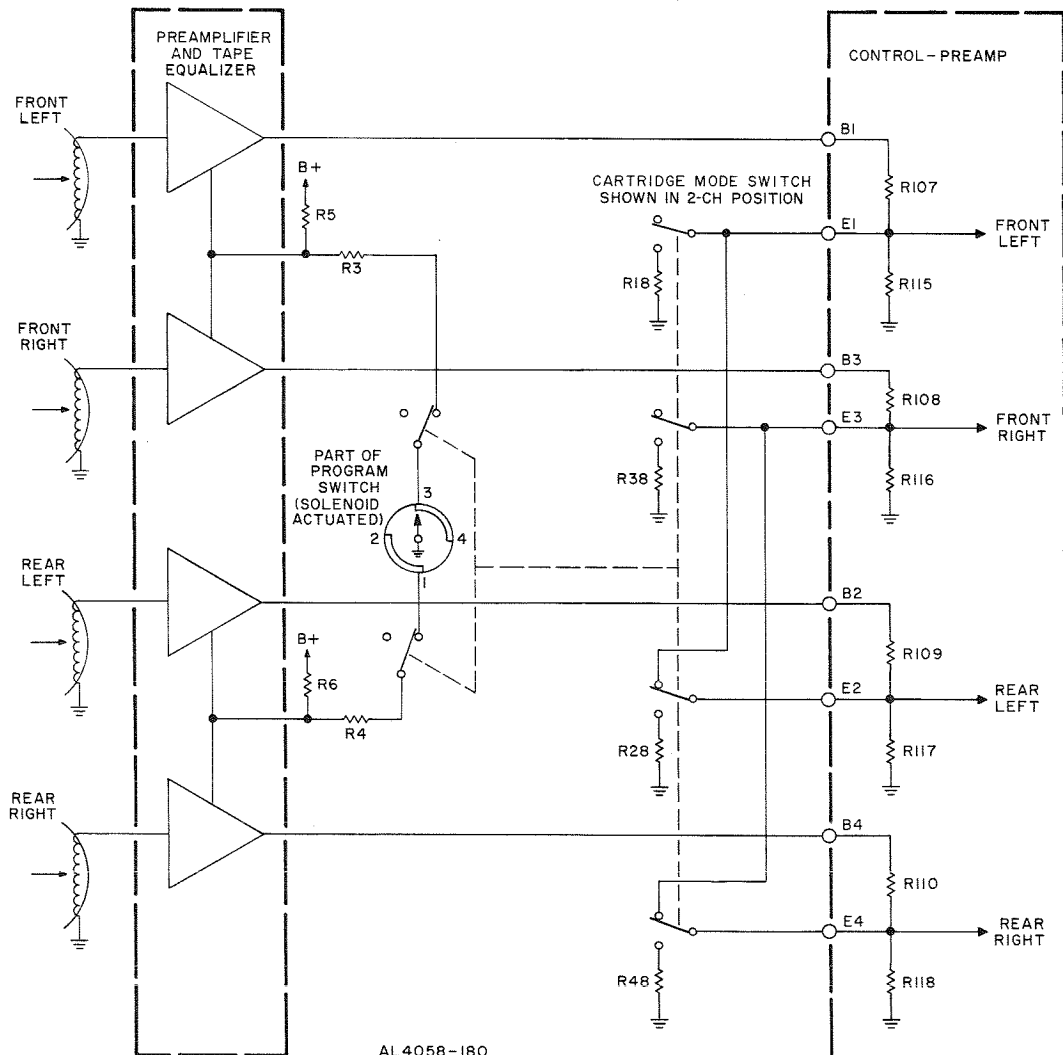

AL 4058-180

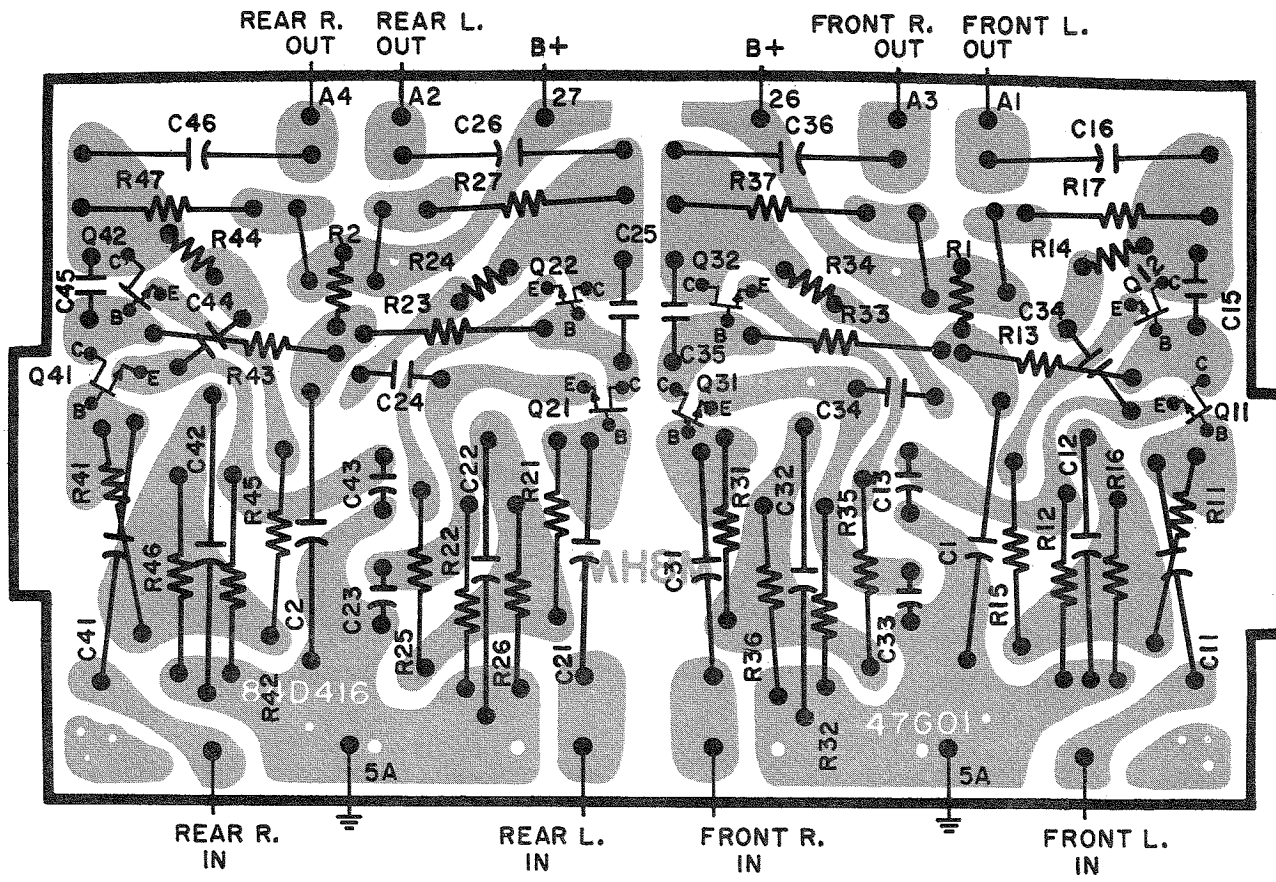

INS 527

COPPER SIDE

PREAMPLIFIER TP4067-270

MISCELLANEOUS

| Symbol                          | Description                  | Part No.   | Sug. Ret. |
|---------------------------------|------------------------------|------------|-----------|
| C1, 2                           | Electrolytic, 40uF, 16V      | TP4067-401 | 1.45      |
| C11, 16, 21, 26, 31, 36, 41, 46 | Electrolytic, 20uF, 16V      | TP4067-403 | .85       |
| C12, 22, 32, 42                 | Electrolytic, 16uF, 16V      | TP4067-404 | 1.45      |
| C13, 23, 33, 43                 | Electrolytic, 0.47uF, 10V    | TP4067-405 | 1.15      |
| C14, 24, 34, 44                 | Mylar, 4700pF, 10%, 50V      | TP4067-406 | 1.00      |
| C15, 25, 35, 45                 | Ceramic, 220pF, 10%, 100V    | TP4067-407 | .85       |
| Q11, 21, 31, 41                 | Transistor                   | TP4067-410 | 3.85      |
| Q12, 22, 32, 42                 | Transistor                   | TP4067-411 | 3.85      |
| R1, 2                           | Composition, 1500, 10%, 1/4W | RC20BF152K | .30       |
| R11, 13, 21, 23, 31, 33, 41, 43 | Composition, 47K, 10%, 1/4W  | RC07BF473K | .40       |
| R12, 22, 32, 42                 | Composition, 150, 5%, 1/4W   | RC07BF151J | .40       |
| R14, 24, 34, 44                 | Composition, 5.6K, 10%, 1/4W | RC07BF562K | .40       |
| R15, 25, 35, 45                 | Composition, 300, 5%, 1/4W   | RC07BF301J | .40       |
| R16, 26, 36, 46                 | Composition, 1K, 10%, 1/4W   | RC07BF102K | .35       |
| R17, 27, 37, 47                 | Composition, 8.2K, 10%, 1/4W | RC07BF822K | .35       |

| Symbol          | Description                              | Part No.   | Sug. Ret. |
|-----------------|--|------------|-----------|
| C5              | Electrolytic, 40uF, 35V                  | TP4067-401 | 1.45      |
| C6              | Electrolytic, 47uF, 35V                  | CE22324-22 | .70       |
| C7              | Ceramic, 0.01, 10%, 600V                 | C2747      | .50       |
| C8              | Mylar, 1.5uF, 250V                       | TP4067-408 | 1.55      |
| CR2             | Diode, Silicon, IRC 1001                 | TP4067-409 | 1.75      |
| M1              | Motor (P/o Motor Assembly)               | TP4067-501 | 30.00     |
| R3, 4           | Composition, 100, 5%, 1/3W               | R33DC101J  | .30       |
| R5, 6           | Composition, 1.2K, 5%, 1/3W              | R33DC122J  | .30       |
| R7              | Wirewound, 330, 10%, 7W                  | TP4067-412 | .85       |
| R18, 28, 38, 48 | Composition, 3.3K, 5%, 1/2W              | RC20BF332J | .35       |
| --              | Lamp, 28V, 40mA                          | LM21436-3  | .60       |
| --              | Lamp Assembly, Cartridge (6 lamps)       | AS521431-2 | 12.00     |
| --              | Solenoid Assembly, Program               | TP4067-504 | 5.45      |
| S8, 9           | Switch, Repeat-Consec, Change            | SP50200-51 | 2.65      |
| S10             | Switch, Cartridge Mode                   | TP4067-133 | .80       |
| S11             | Switch, Program (P/o Cam Shaft Assembly) | TP4067-505 | 5.25      |
| S12             | Microswitch, AC                          | TP4067-024 | 4.05      |

## SUGGESTED TEST CARTRIDGES

| RCA No. | Description   |
|---------|---|
| 323     | 400Hz, full track, at standard recording level, in a 2-channel cartridge shell.               |
| 326     | 8kHz, full track azimuth alignment, in a 2-channel cartridge shell.                           |
| 340     | Check for proper head indexing and channel orientation.                                       |
| 353     | 3.15kHz wow and flutter.  |
| 523     | Same as 323, in a 4-channel cartridge shell.  |
| 526     | Same as 326, in a 4-channel cartridge shell.  |
| 540     | Same as 340, in a 4-channel cartridge shell.  |
| 554     | 1kHz, recorded on tracks 2 and 6 at standard recording level, in a 4-channel cartridge shell. |
| 572     | Spot frequency test containing 50Hz, 1kHz, and 8kHz tones                                     |

Order tapes directly from:  
**RCA RECORDS**  
 Special Products Division  
 1133 AVENUE OF THE AMERICAS  
 NEW YORK, N. Y. 10036

## SOLENOID END-STOP ADJUSTMENT

- (1) Insert any 2-CH or 4-CH cartridge. A test cartridge is not required.
- (2) Back-out solenoid end-stop adjustment (42) until the tape head completely stops indexing.
- (3) Turn end-stop adjustment in the opposite direction 1 turn.
- (4) Check operation by indexing head several times. Program lights should advance in the proper sequence.

## AZIMUTH ALIGNMENT

- (1) Connect an AC VTVM to the FRONT-R RCDR OUT jack and set SELECTOR to CARTRIDGE position. Insert test cartridge 323 or 523.
- (2) Adjust the azimuth alignment screw (18) for maximum output.
- (3) Insert test cartridge 326 or 526 and adjust for maximum output as in step (2).
- (4) Lock adjustment screw in place using glyptol, loctite, Duco, or other suitable cement. Be careful to avoid getting cement on the drive belt.

## HEAD HEIGHT ADJUSTMENT

- (1) Set BASS and TREBLE controls to minimum. (This reduces the noise level so that head height may be more accurately adjusted to reduce crosstalk.) Set SELECTOR to CARTRIDGE and MODE/EXT TAPE MONITOR to 4-CH STEREO.
- (2) Connect an AC VTVM to MAIN FRONT-R SPEAKER terminal and press MAIN SPKRS pushbutton. Insert test cartridge 554 and press CHANGE pushbutton to play PROGRAM 2.
- (3) Loosen lock nut (52) located on the bottom of cam bracket (51) and adjust cam shaft (50) for maximum output.
- (4) Connect AC VTVM to MAIN FRONT-L SPEAKER terminal and check output as outlined above.
- (5) Reconnect AC VTVM to MAIN FRONT-R SPEAKER terminal and press CHANGE pushbutton to play PROGRAM 1. The noise/crosstalk level should be -45dB or better.

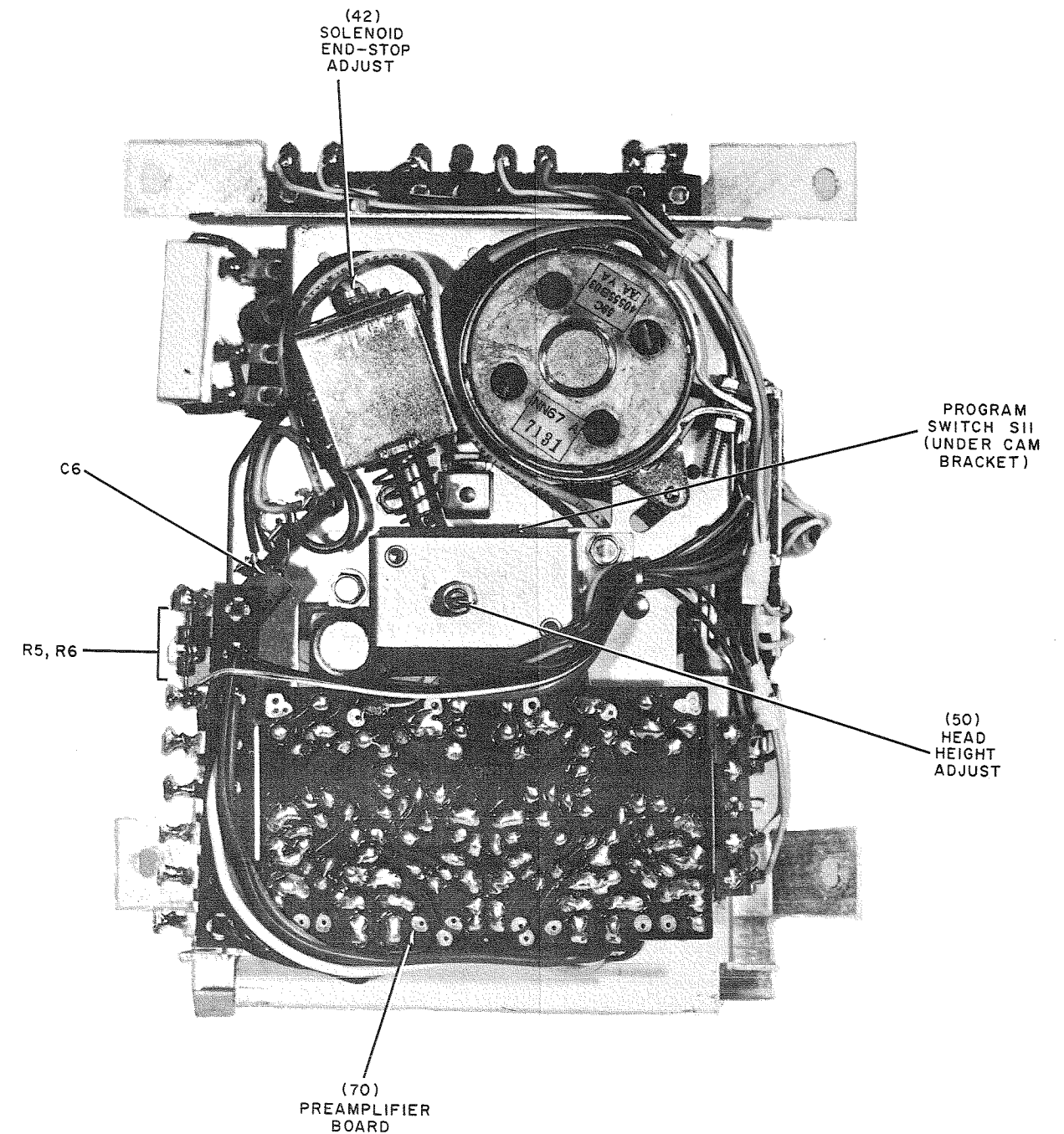
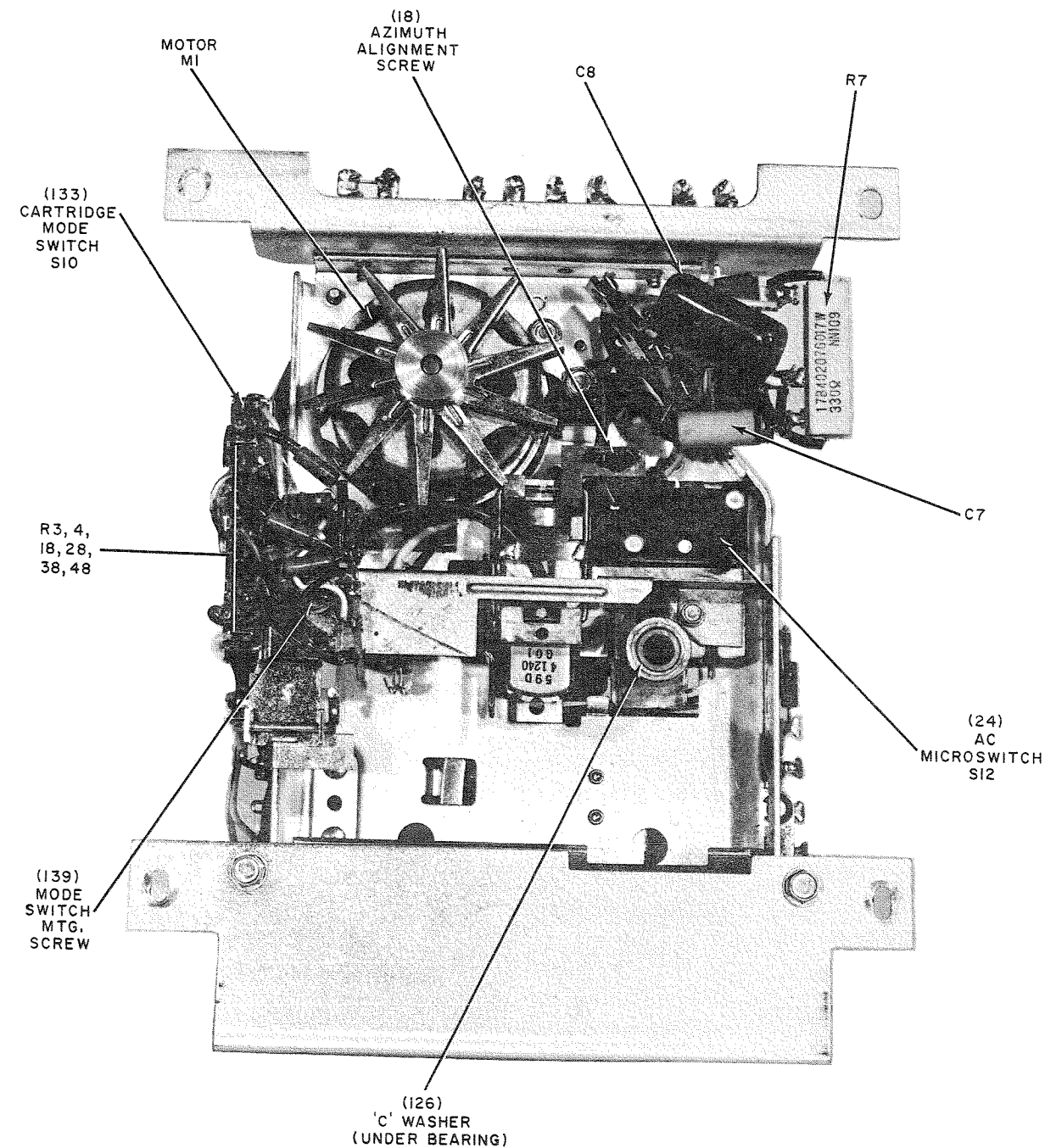

## CARTRIDGE PLAYER DISASSEMBLY

**NOTE:** Index numbers used in parenthesis refer to exploded view.

### REMOVING FLYWHEEL

- (1) Remove cartridge player from chassis.
- (2) Remove drive belt (10).
- (3) Rotate flywheel so that the two ends of 'C' washer (126) are accessible from the front.
- (4) Using two small bladed screwdrivers (or similar tools) push both ends of 'C' washer simultaneously to displace it from shaft.
- (5) Rotate flywheel so that the rounded portion of 'C' washer is at the front. Insert a small, pointed tool (preferably with a right angle bend at the tip) in the cutaway portion of the 'C' washer, between the washer and shaft, and pull washer from shaft.
- (6) Remove flywheel (15) and flywheel spacer (131).

### REMOVING HEAD-MOUNT/CAPSTAN HOUSING

- (1) Remove flywheel.
- (2) Remove antistatic bracket (111) by taking out holding screw (1).
- (3) Remove screw (21) near the capstan well which secures shield (22).
- (4) Remove cartridge mode switch (133), and terminal strip by removing terminal strip mounting screw (139). Remove actuating arm (125) from the switch.
- (5) Remove screws (128) and (129) holding the cartridge mode switch mounting bracket (127) to the side of the chassis.
- (6) Unsolder shield (22) mounted in a slot in the mechanism frame. Be careful not to bend the shield when removing it.
- (7) Remove screw (36) holding solenoid terminal strip (136).
- (8) Remove screw (53) holding cam bracket (51).
- (9) Remove screw (35) located between solenoid and cam bracket.
- (10) Remove the two screws holding the AC microswitch (24). Remove the switch insulator (26) and motor actuating arm (25).
- (11) Remove the playback head. Refer to REMOVING PLAYBACK HEAD procedure.
- (12) Lift the capstan housing assembly (C) slightly and slide the head connector between the cross spring.
- (13) Lift the head and capstan housing assembly from the chassis.

**CAUTION:** The head transfer pin (68) is now free and will fall out if the chassis is turned upside-down. The rounded edge of this pin goes toward the switch, the flat side faces the head.

### REMOVING PLAYBACK HEAD

- (1) Remove flywheel.
- (2) Loosen allen-head screw (97) securing playback head.
- (3) Loosen head in mount by applying a slight downward pressure (with index finger), at the upper front edge of the head.
- (4) Slide the head and cable assembly out the front of the head retainer (95). Carefully pull the head out of the head socket connector (93).

**NOTE:** The colored dot on the top of the socket, and the dot on the top rear (pin side) of the head show correct orientation when the head is replaced.

- (5) Remove the metal shim (124) located beneath the head on the front edge of the bracket.

**INSTALLATION CAUTION:** Before plugging head into socket, place a small-bladed screwdriver (or similar tool) between the cross bracket and the front part of the head bracket to support the rear of the socket. Then, carefully push head into socket.

### REMOVING MOTOR

- (1) Lift off drive belt (10).
- (2) Unsolder motor wires from terminal strip (136).
- (3a) If the pulley/fan assembly (4) is set-screw mounted, loosen the screw and remove the assembly.
- (3b) On some units, the motor shaft and pulley/fan assembly are cemented together. The assembly can be removed by inserting a small screwdriver under the fan to pry the pulley/fan assembly from the shaft while heating the motor shaft with a soldering iron (to soften the cement).
- (4) Remove tension adjustment screw (11), noting its original position. Remove screw (6) on opposite mounting bracket.
- (5) Carefully remove motor, motor bracket (8), and shield (9) intact.

**INSTALLATION NOTE:** As a guide, use a straight-edge across the flywheel and pulley when adjusting the height of the motor, so that the flat end of the pulley and top of flywheel are in the same plane.

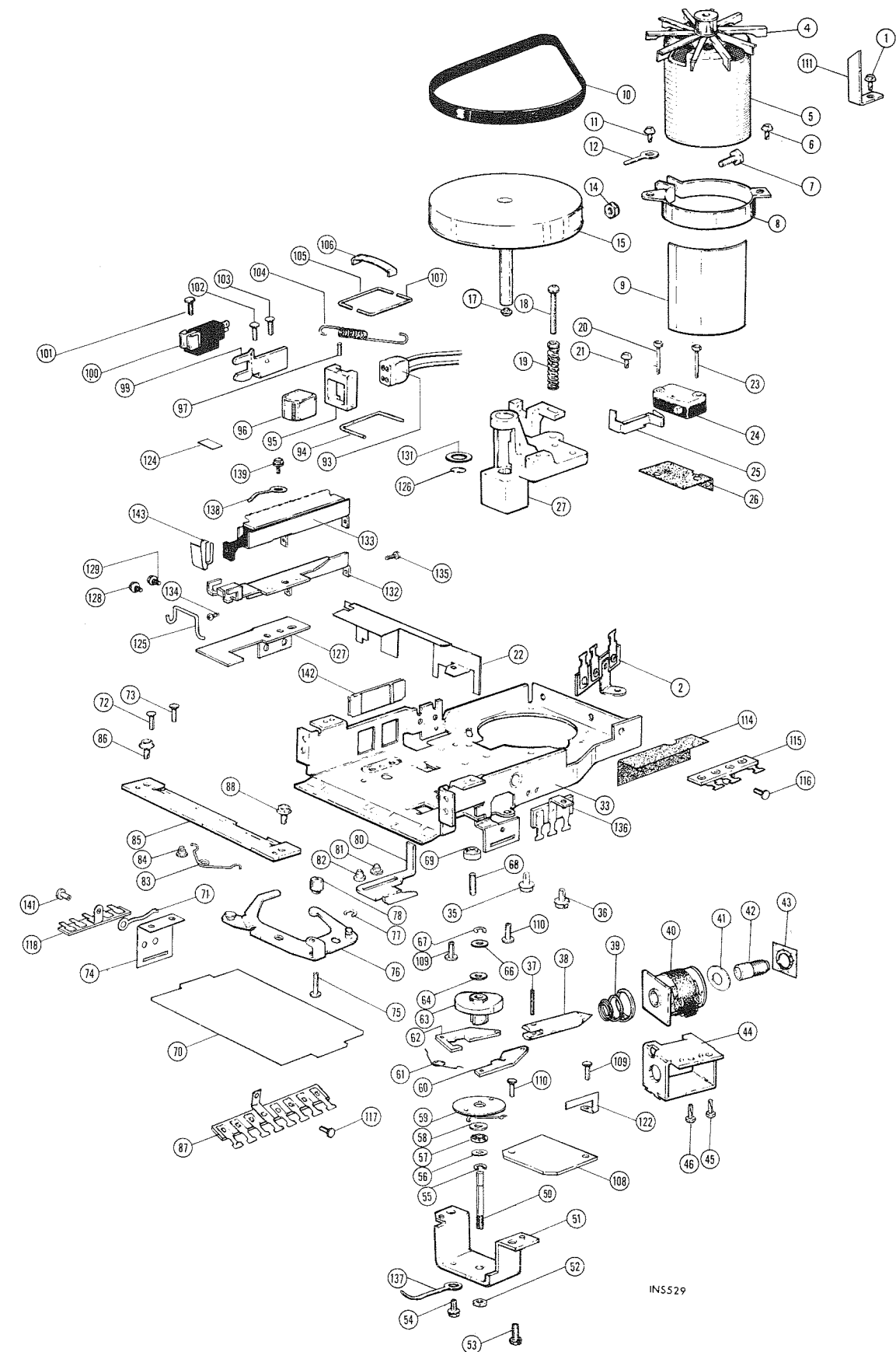

INS529

## MECHANICAL PARTS

| Item       | Description                  | Part No.      | Sug. Ret. | Item       | Description              | Part No.      | Sug. Ret. |
|------------|------------------------------|---------------|-----------|------------|--------------------------|---------------|-----------|
| 1, 6, 11   | Screw, Tpg: 6-32x¼           | TP4067-201    | .10       | 67         | Washer, 'C'              | p/oTP4067-505 | --        |
| 2          | *Terminal Strip              | --            | --        | 68         | Transfer Pin             | TP4067-068    | .95       |
| 4          | Pulley/Fan Ass'y: 60Hz       | TP4067-004    | 3.50      | 69         | Transfer Pin Bushing     | TP4067-069    | .65       |
| -          | Pulley/Fan Ass'y: 50Hz       | TP21349       | 3.50      | 70         | Preamplifier Board       | TP4067-270    | 29.75     |
| A          | Motor less Pulley/Fan        | TP4067-501    | 30.00     | 71         | *Wraparound Lug          | --            | --        |
| 5          | Motor Only                   | p/oTP4067-501 | --        | 72, 73,    |                          |               |           |
| 7          | Screw, Tpg: 8-32x¾           | p/oTP4067-501 | --        | 116, 141   | *Rivet: .122x1/8         | --            | --        |
| 8          | Motor Mounting Bracket       | p/oTP4067-501 | --        | 74         | Spring Bracket           | TP4067-074    | .55       |
| 9          | Magnetic Shield              | p/oTP4067-501 | --        | 75         | *Rivet: .088x15/32       | --            | --        |
| 10         | Drive Belt                   | TP4067-010    | 1.60      | 76         | Ejector Lever            | TP4067-076    | 1.20      |
| 12         | *Wraparound Lug              | --            | --        | 77         | Washer, 'C'              | TP4067-077    | .35       |
| 14         | Nut, Hex: 8-32               | p/oTP4067-501 | --        | 78         | Cartridge Return Roller  | TP4067-078    | .40       |
| B          | Flywheel Ass'y               | TP4067-502    | 2.30      | 80         | Slide Bracket            | TP4067-080    | .55       |
| 15         | Flywheel and Shaft           | p/oTP4067-502 | --        | 81, 82, 84 | *Shoulder Rivet          | --            | --        |
| 17         | Capstan Shaft Bearing        | p/oTP4067-502 | --        | 83         | Ejector Spring           | TP4067-083    | .55       |
| 18         | Screw, Mach: 4-40x¾          | TP4067-018    | .20       | 85         | Hold-Down Bracket        | TP4067-085    | .65       |
| 19         | Azimuth Adjust Spring        | TP4067-019    | .40       | 86, 88     | Screw, Tpg: 8-32x¼       | TP4067-086    | .40       |
| 20, 23     | Screw, Tpg: 4-40x5/8         | TP4067-020    | .10       | 87         | *Terminal Strip          | --            | --        |
| 21         | Screw, Tpg: 4-40x¼           | TP4067-021    | .40       | 93         | Head Socket Connector    | TP4067-093    | 3.00      |
| 22         | *Shield                      | --            | --        | 94         | L (bottom) Radius Arm    | p/oTP4067-503 | --        |
| 24         | AC Microswitch               | TP4067-024    | 4.05      | 95         | Head Retainer            | p/oTP4067-503 | --        |
| 25         | Motor Actuating Arm          | TP4067-025    | .70       | 96         | Tape Head, 4-Channel     | TP4067-096    | 30.00     |
| 26         | *Switch Insulator            | --            | --        | 97         | Screw, Tpg: 4-40x3/16    | TP4067-097    | .40       |
| C          | Capstan Housing Ass'y        | TP4067-503    | 7.15      | 99         | Tape Guide Bracket       | TP4067-099    | 1.00      |
| 27         | Capstan Housing/Block        | p/oTP4067-503 | --        | 100        | Track Switch             | TP4067-100    | 1.15      |
| 33         | *Chassis                     | --            | --        | 101, 102,  |                          |               |           |
| 35, 36     | Screw, Tpg: 8-32x9/32        | TP4067-035    | .10       | 103, 109,  |                          |               |           |
| 37         | Spiral Pin (Ratchet Plunger) | TP4067-037    | .50       | 110, 117   | *Rivet: 122x3/16         | --            | --        |
| 38         | Solenoid Plunger             | TP4067-038    | .85       | 104        | Head Tension Spring      | TP4067-104    | .85       |
| 39         | Solenoid Spring              | TP4067-039    | .40       | 105        | L (top) Radius Arm       | p/oTP4067-503 | --        |
| D          | Solenoid Ass'y               | TP4067-504    | 5.45      | 106        | Spring Clip              | p/oTP4067-503 | --        |
| 40         | Solenoid Coil                | p/oTP4067-504 | --        | 107        | R (top) Radius Arm       | p/oTP4067-503 | --        |
| 41         | Spring Washer                | p/oTP4067-504 | --        | 108        | Program Switch Stator    | p/oTP4067-505 | --        |
| 42         | Solenoid Stop                | p/oTP4067-504 | --        | 111        | Antistatic Bracket       | TP4067-211    | 1.00      |
| 43         | Spring Nut                   | p/oTP4067-504 | --        | 114        | *Terminal Insulator      | --            | --        |
| 44         | Solenoid Bracket             | p/oTP4067-504 | --        | 115        | *Terminal Strip          | --            | --        |
| 45, 46     | Screw, Mach: 6-32x5/32       | TP4067-045    | .10       | 118        | *Terminal Strip          | --            | --        |
| E          | Cam Shaft Ass'y              | TP4067-505    | 5.15      | 122        | Spring                   | p/oTP4067-505 | --        |
| 50         | Cam Shaft                    | p/oTP4067-505 | --        | 124        | Head Shim                | TP4067-124    | .50       |
| 51         | Cam Bracket                  | p/oTP4067-505 | --        | 125        | Actuating Arm            | TP4067-125    | .70       |
| 52         | Nut, Hex: 8-32               | p/oTP4067-505 | --        | 126        | Washer, 'C'              | TP4067-126    | .50       |
| 53         | Screw, Tpg: 8-32x3/8         | TP4067-053    | .40       | 127        | *Switch Mounting Bracket | --            | --        |
| 54         | Screw, Tpg: 6-20x¼           | TP4067-054    | .40       | 128, 129   | Screw, Tpg: 8-18x¼       | TP4067-128    | .10       |
| 55         | Washer, 'C'                  | p/oTP4067-505 | --        | 131        | Flywheel Spacer          | TP4067-131    | .35       |
| 56, 58, 66 | Washer, Flat                 | p/oTP4067-505 | --        | 132        | Switch Bracket           | TP4067-132    | 1.60      |
| 57         | Thrust Bearing               | p/oTP4067-505 | --        | 133        | Switch, Cartridge Mode   | TP4067-133    | .80       |
| 59         | Program Switch Rotor         | p/oTP4067-505 | --        | 134, 135   | Screw, Tpg: 6-40x¼       | TP4067-134    | .10       |
| 60         | Push Ratchet Pawl            | TP4067-060    | .50       | 136        | *Terminal Strip          | --            | --        |
| 61         | Pawl Tension Spring          | TP4067-061    | .50       | 137, 138   | *Wraparound Lug          | --            | --        |
| 62         | Pull Ratchet Pawl            | TP4067-062    | .50       | 139        | Screw, Tpg: 6-20x¼       | TP4067-054    | .10       |
| 63         | Ratchet Cam                  | p/oTP4067-505 | --        | 142        | Cartridge Guide Spacer   | TP4067-142    | .40       |
| 64         | Spring Washer                | p/oTP4067-505 | --        | 143        | Actuating Arm            | TP4067-143    | .65       |

\*Replacement part NOT supplied by Fisher Radio

**CAUTION: IN ANALYZING THE CAUSE OF COMPLAINT, DO NOT INSERT ADDITIONAL TAPE CARTRIDGES UNTIL THE POSSIBLE CAUSE AND REMEDY HAVE BEEN REFERRED TO IN THIS GUIDE.**

| SYMPTOM  | CAUSE   | REMEDY   |
|--|---|--|
| Tape breaks or winds up around capstan shaft.                              | 1. Defective tape cartridge.  | Replace cartridge with known good cartridge.   |
| Squealing or excessive wow.  | 1. Defective tape cartridge.<br>2. Defective capstan shaft and/or bearings.   | Replace cartridge with known good cartridge.<br>Replace flywheel assembly, and/or capstan housing.   |
| Drive belt slips off flywheel (also slow tape start-up).                   | 1. Defective Drive belt.<br>2. Motor bracket bent (drive shaft not vertical).   | Replace drive belt.<br>Straighten bracket. If belt rides high on pulley, insert screwdriver between motor and flywheel (in circular slot of chassis) and pry motor away from flywheel until shaft is aligned. If belt rides low, insert screwdriver in slot on opposite side of motor and pry toward flywheel until aligned.<br><b>CAUTION: DO NOT APPLY PRESSURE TO PULLEY.</b>   |
| Tape pulls out of center of cartridge when cartridge is removed from unit. | 1. Undersized or burred tape guide slot.  | Deburr slot or replace guide bracket.  |
| Poor tape drive (also wow and flutter).                                    | 1. Flywheel and/or motor pulley dirty or greasy.<br>2. Drive belt improperly installed.<br>3. Drive belt defective (stretched, etc.).<br>4. Defective capstan shaft, and/or bearings.   | Use isopropyl alcohol to clean the outer edge of flywheel, motor pulley, and capstan shaft.<br>Make certain rough surface of belt is on inside. (Rough surface drives flywheel.) On belts with stripes, install belt with stripes on outside.<br>Replace drive belt.<br>Replace flywheel assembly, and/or capstan housing.   |
| Crosstalk.   | 1. Defective tape cartridge.<br>2. Tape head out of adjustment.<br>3. Head mounting hardware binding.<br>4. Tape guide bracket not positioning tape correctly with respect to head.<br>5. Defective cam and shaft assembly.<br>6. Tape head not indexing correctly. | Replace cartridge with known good cartridge.<br>Check head height and azimuth adjustments as outlined on page 19<br>Check for obstructions or bent mounting rods. Index head to lower position, then lift up head. It should have sufficient tension to spring back without binding.<br>Check distance between bottom edge of tape guide bracket and chassis. If distance is not .095 to .100, replace tape guide bracket.<br>Replace cam and shaft assembly.<br>See "Improper Head Indexing". |
| Motor does not run when cartridge is inserted.                             | 1. Microswitch not actuated.  | Replace switch, or bend actuating arm enough to actuate switch when cartridge is inserted.   |
| Intermittent audio during tape operation.                                  | 1. Intermittent tape-capstan, or tape-to-head contact.<br>2. Intermittent head-connecting cable.  | See "Poor Tape Drive".<br>Determine if cable is faulty by wiggling receptacle end of cable, or feed a signal into input of preamplifier. If cable is faulty, replace.  |
| Improper head indexing, intermittent head indexing.                        | 1. Inadequate tension on solenoid plunger return spring.<br>2. Defective plunger.<br>3. Solenoid plunger end-stop screw not properly adjusted.<br>4. Cam tension spring out of hole, or missing.<br>5. Defective cam and shaft assembly.                            | Increase spring tension, or replace spring.<br>Replace solenoid plunger.<br>Adjust solenoid end-stop screw as outlined on page 19<br>Insert spring into its hole, or replace spring.<br>Replace cam and shaft assembly.  |
| Unit does not change Program   | 1. Solenoid not operating.<br>2. Tape head not indexing properly.   | Check solenoid circuit. Repair or replace defective parts.<br>See "Improper Head Indexing".  |
| Slow speed (also see "Poor Tape Drive").                                   | 1. Binding tape cartridge.<br>2. Defective drive belt.<br>3. Defective capstan shaft, and/or bearings.  | Replace cartridge with known good cartridge.<br>Replace drive belt.<br>Replace flywheel assembly, and/or capstan housing.  |

0  
1  
2  
3  
4  
5  
6  
7  
8  
9

---

---

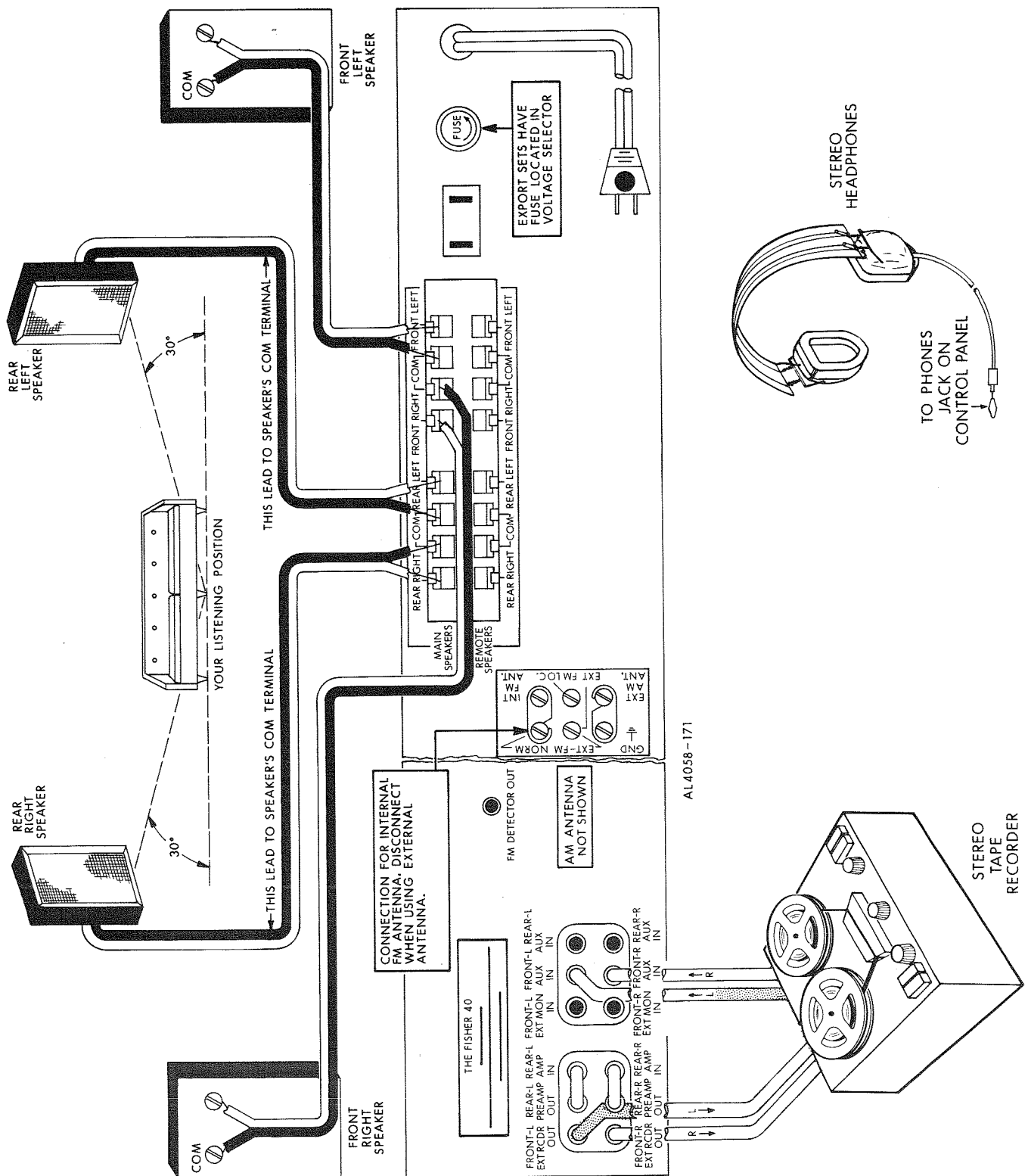

BECAUSE ITS PRODUCTS ARE SUBJECT TO CONTINUOUS IMPROVEMENT, FISHER RADIO RESERVES THE RIGHT TO MODIFY ANY DESIGN OR SPECIFICATION WITHOUT NOTICE AND WITHOUT INCURRING ANY OBLIGATION.

**FISHER RADIO • LONG ISLAND CITY • NEW YORK 11101**