

Service Manual

AL Pugliese
The Fisher Doctor
Fisher Radio Corporation
27 Daleham Street
Staten Island, NY 10308

THE FISHER[®]

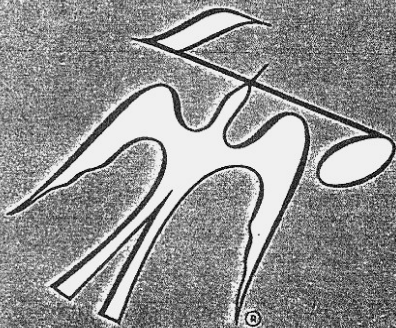

400

CHASSIS SERIAL NUMBERS
BEGINNING 48001

\$1.00

FISHER RADIO CORPORATION • LONG ISLAND CITY 1 • NEW YORK

TROUBLESHOOTING GUIDE

Does not go on (pilot or dial lamps do not light).

- Check:
- Fuse F1.
 - AC plug and line cord.
 - Wall outlet.
 - Power switch S6 (use test lamp in AC OUTLET on rear of chassis).

Fuse blows as soon as replaced.

- Check:
- CR1, CR2, CR3; C56, C57C, C60, C63 in power supply.
 - C43, C45, C47, C49, C62 filament bypass capacitors.

Distortion
Hum, Weak or
No audio output

(both channels) in any position of SELECTOR switch.

- Set BALANCE, TREBLE and BASS controls to NORMAL.
 - Remove plugs from rear-chassis RCRDR OUT and TAPE MON jacks.
 - Remove plugs from SPACEEXPANDER jacks and insert jumpers (a must).
 - Remove plugs from rear-chassis PHONO, TAPE HEAD and AUX jacks.
- Test:
- V10, V11 or substitute. (Filament leakage test for hum – gas test for distortion.)
 - Supply voltage at: CR2, C56, R41; C56, C57C, R43; C57B, R42, R43; C57A, R42; C52D, R40, R41; C52C, R39, R40; C52B, R38, R39; C52A, R33, R38.
 - Bias-supply voltages at: CR1, C60A, C60B; C42, R34, R35.
 - DC Filament-supply voltage.

Distortion
Hum, Weak or
No Audio output

(LEFT channel only) in any position of SELECTOR.

- Remove plugs from rear-chassis RCRDR OUT and TAPE MON jacks (left channel).
 - Remove plug from SPACEEXPANDER jack (left channel) and insert jumper (a must).
- Check:
- Position of BALANCE, TREBLE and BASS controls (set to NORMAL positions).
 - Position of PHASE INVERTER ADJ. (R107).
- Test:
- V12, V14, V15 or substitute. (Filament leakage test for hum – gas test for distortion.)
 - Voltages at sockets for V10, V11, V12, V14, V15.

Distortion
Hum, Weak or
No audio output

(RIGHT channel only) in any position of SELECTOR.

- Remove plugs from rear-chassis RCRDR OUT and TAPE MON jacks (right channel).
 - Remove plug from SPACEEXPANDER jack (right channel) and insert jumper (a must).
- Check:
- Position of BALANCE, TREBLE and BASS controls (set to NORMAL positions).
 - Position of PHASE INVERTER ADJ. (R108).
- Test:
- V13, V16, V17 or substitute. (Filament leakage test for hum—gas test for distortion.)
 - Voltages at sockets for V10, V11, V13, V16, V17.

Distortion
Hum, Weak or
No audio output

(LEFT channel only) PHONO and TAPE HEAD positions of SELECTOR.

- Remove plugs from rear-chassis PHONO and TAPE HEAD jacks (for hum).
 - Switch LEFT channel plug to RIGHT channel jack (for distortion, weak or no audio output).
- Check:
- Jack, plugs and interconnecting cables.
 - Phono cartridge, or tape head output.
- Test:
- V8 or substitute. (Filament leakage test for hum—gas test for distortion.)

Distortion
Hum, Weak or
No audio output

(RIGHT channel only) PHONO and TAPE HEAD positions of SELECTOR.

- Remove plugs from rear-chassis PHONO and TAPE HEAD JACKS (for hum).
 - Switch RIGHT channel plug to LEFT channel jack. (for distortion, weak or no audio output).
- Check:
- Jack, plugs and interconnecting cables.
 - Phono cartridge, or tape head output.
- Test:
- V8 or substitute. (Filament leakage test for hum—gas test for distortion.)

Distortion
Hum, Weak or
No audio output

(BOTH channels) all FM positions of SELECTOR.

- Tune to other FM stations—watch tuning indicator.
- Check:
- Antenna position and connections.
 - IF and RF alignment.
- Test:
- V1, V2, V3, V4, V5, V6 or substitute.
 - (Filament leakage test for hum—gas test for distortion.)
 - Voltages at sockets for V1, V2, V3, V4, V5, V6 and ratio detector.

Distortion

(BOTH channels) FM STEREO positions of SELECTOR only.

- Tune to other FM-Stereo stations—watch tuning indicator.
- Check:
- Antenna position and connections.
 - MPX, IF and RF alignment.
- Test:
- Voltages at sockets for V1, V2, V3, V4, V5, V6 and ratio detector.
 - V100, V101, V102 or substitute. (Filament leakage test for hum—gas test for distortion.)
 - Voltages at MPX-decoder tube sockets V100, V101, V102.

DIAL STRINGING PROCEDURE

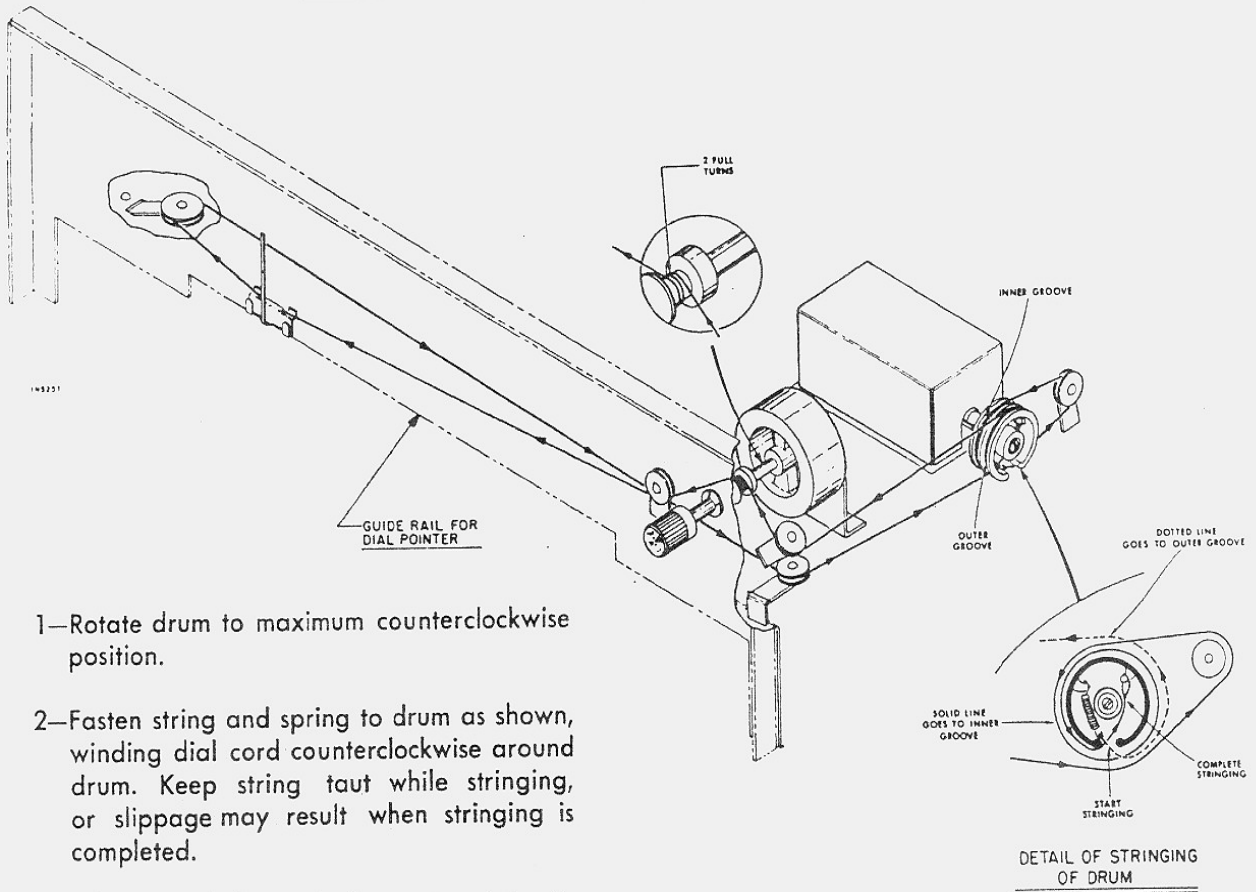

- 1—Rotate drum to maximum counterclockwise position.
- 2—Fasten string and spring to drum as shown, winding dial cord counterclockwise around drum. Keep string taut while stringing, or slippage may result when stringing is completed.
- 3—After completing stringing, set pointer to zero (0) on the dial logging scale, and glue pointer to dial cord.

If replacement parts are out of stock, locally, they may be obtained directly from the Parts Department of FISHER Radio Corporation. They will be shipped "best way", either prepaid or C.O.D. unless otherwise specified.

For instrument-operation information and technical assistance write Richard Hamilton, Customer Relations Department, FISHER Radio Corporation, Long Island City, New York 11101.

PHASE INVERTER ADJUSTMENT

- LEFT CHANNEL**
- 1 — Connect a 16-ohm load between the Left Speaker terminals. Connect the Left Impedance Selector to the "16" terminal.
 - 2 — Connect the input of the IM Distortion Analyzer across the 16-ohm load.
 - 3 — Connect the IM Distortion Analyzer output to the Left AUX input jack.
 - 4 — Set the Selector switch to AUX and adjust the Analyzer for 14 volts across the 16-ohm load.
 - 5 — Adjust the Left Phase Inverter Adjust control for minimum IM distortion.

- RIGHT CHANNEL**
- 1 — Connect a 16-ohm load between the Right Speaker terminals. Connect the Right Impedance Selector to the "16" terminal.
 - 2 — Connect the input of the IM Distortion Analyzer across the 16-ohm load.
 - 3 — Connect the IM Distortion Analyzer output to the Right AUX input jack.
 - 4 — Set the Selector switch to AUX and adjust the Analyzer for 14 volts across the 16-ohm load.
 - 5 — Adjust the Right Phase Inverter Adjust control for minimum IM distortion.

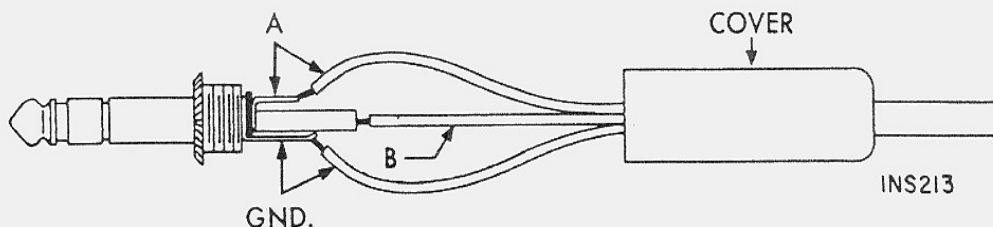

CONNECT GND TO COMMON OR GROUND TERMINAL OF HEADPHONES; A TO HOT TERMINAL OF LEFT CHANNEL; B TO HOT TERMINAL OF RIGHT CHANNEL.

Headphone plug wiring

MULTIPLEX DECODER ALIGNMENT

STEPS	GENERATOR			INDICATOR	ALIGNMENT		
	CONNECTION	AUDIO FREQUENCY	RF MODULATION	TYPE & CONNECTION	ADJUST	INDICATION	NOTES
1	Audio oscillator connected to lug 1	80 KC—1 volt	None	AC VTVM to junction of C210 and R228	L100 (Use hex alignment tool)	Minimum voltage	
2	Multiplex generator audio output to lug 1 (See Note 1)	19 KC (± 5 cps) pilot tone, 100 mv	None	DC VTVM to T.S.P. 101	Z100 top and bottom (Use hex alignment tool)	Maximum voltage	1
3	Same as Step 2	19 KC pilot tone, 50 mv	None	Scope horiz. input to 19 KC output of gen.; vert. input to junction of C216 and R209. External sweep	Z101 (Use K-tran alignment tool)	Stable 2:1 Lissajous pattern. Disregard phase of pattern	1
4	Same as Step 2	19 KC	None	Same as Step 3	Vary generator 19 KC output from 50 to 200 mv	Lissajous pattern should remain stationary over the entire 150 mv range	1, 2
5	Same as Step 2	1000 cps on left (A) channel only, 1 volt rms (2.8 P-P)	None	AC VTVM and scope vert. input to channel A output lug. Internal sweep. DC VTVM to T.S.P. 101	Z100 top (Use hex tool)	Maximum indication on AC VTVM. Clean 1000 cps waveform on scope	1, 3
6	Same as Step 2	1000 cps on right (B) channel only, 1 volt rms (2.8 P-P)	None	Same as Step 5	MPX separation R215	Minimum reading on AC VTVM should be at least 33 db below reading obtained in Step 5	1
7	Same as Step 2	Same as Step 6	None	Move scope input and AC VTVM to channel B output lug	-----	Note and record voltage reading on AC VTVM	1
8	Same as Step 2	1000 cps on left (A) channel only, 1 volt rms (2.8 P-P)	None	Same as Step 7	-----	AC VTVM reading should be at least 33 db below reading observed in Step 7	1
9	Same as Step 2	8000 cps on right (B) channel only, 1 volt rms (2.8 P-P)	None	Same as Step 7	-----	AC VTVM reading should be the same as observed in Step 7	1
10	Same as Step 2	8000 cps on left (A) channel only, 1 volt rms (2.8 P-P)	None	Same as Step 7	-----	AC VTVM reading should be at least 18 db below reading observed in Step 9	1
11	Repeat Steps 9 and 10 with scope and AC VTVM connected to channel A output lug, but start with 8000 cps applied to left channel for first reading, then switch to right channel for second reading.						
12	Multiplex generator RF output to 300-ohm antenna terminals	1000 cps on left (A) channel only	100% (75 KC Dev.) No pre-emphasis	Move scope input and AC VTVM to channel A output lug	-----	Note and record voltage reading on AC VTVM	4
13	Same as Step 12	1000 cps on right (B) channel only	Same as Step 12	Same as Step 12	R215	Minimum reading on AC VTVM should be at least 33 db below reading observed in Step 12	4
14	Same as Step 12	8000 cps on left (A) channel only	Same as Step 12	Same as Step 12	-----	AC VTVM reading should be 10 db below reading observed in Step 12	4
15	Same as Step 12	8000 cps on right (B) channel only	Same as Step 12	Same as Step 12	-----	AC VTVM reading should be 28 db below reading observed in Step 12	4

NOTE: The above procedure is based on the use of the FISHER Model 300 Multiplex Generator.

1 — In steps 2 through 11, the audio output of the Multiplex Generator should be connected to lug 1 of the multiplex sub-chassis through a 12,000 ohm, 1/2-watt, carbon resistor, and a 180 uuf capacitor should be connected between lug 1 and ground. The wiring from the MPX TEST jack on the main chassis to lug 1 must be disconnected during Steps 2 through 11.

2 — The vertical amplitude of the Lissajous pattern will increase slightly

as the generator output is increased. This is a normal occurrence.

3 — If DC VTVM reading falls below -9 volts when maximum reading is obtained on the AC VTVM, readjust bottom of Z100, then repeat Step 5. Repeat this procedure until maximum AC VTVM reading is obtained with DC VTVM reading greater than -9 volts.

4 — Tune the FISHER to the RF output frequency of the Multiplex Generator.

1007 MULTIPLEX DEC

CAPACITORS

10% tolerance for all fixed capacitors, unless otherwise noted or marked GMV (guaranteed minimum value). All capacitors not marked μf are pF (μuf).

Symbol	Description	Part No.
C200	Ceramic, .01 μf , +80 -20%, 500V	C50089-7
C201	Ceramic, 680, 1000V	C50072-2
C203	Ceramic, 220, 1000V	C50183-3
C204	Polystyrene, 470, 5%, 500V	C50394-1
C205	Ceramic, 82, 1000V	C50070-1
C206	Ceramic, 1000, GMV, 500V	C50089-2
C207	Ceramic, 5000, +80 -20%, 500V	C50089-6
C208, 209	Mica, 4700, 5%, 500V	C50332-5
C210	Electrolytic, 1 μf , 350V	C50283-3
C211	Ceramic, 1000, GMV, 500V	C50089-2

C212	Ceramic, 5000, 20%, 500V	C50089-1
	*Ceramic, .05 μF , +80% -20%	C50073-2
C214	Mylar, 4700, 400V	C50197-25
C215	Mica, 3900, 5%, 500V	C50332-6
C216, 217	Ceramic, 1000, GMV, 500V	C50089-2
C218	Ceramic, .02 μf , 20%, 500V	C50089-5
C219	Ceramic, 330, 1000V	C50183-5
C220	Ceramic, .02 μf , 20%, 500V	C50089-5
C221, 222	Mylar, .047 μf , 250V	C50197-52
C223, 224	Ceramic, 1000, 1000V	C50072-3
C225, 226	Ceramic, 2200, 1000V	C50072-5

*Model 400 only

RESISTORS

In ohms, 5% tolerance, $\frac{1}{4}$ W unless otherwise noted. K = Kilohms, M = Megahms.

Symbol	Description	Part No.
R200	Composition, 22M, 10%, $\frac{1}{2}$ W	RC208F226K
R201		
R202		
R203		
R204		
R205		
R206		
R207, 208		
R209		
R210		
R211, 212		
R213, 214		
R215		
R216		
R217, 218		
R219, 220		
R221		

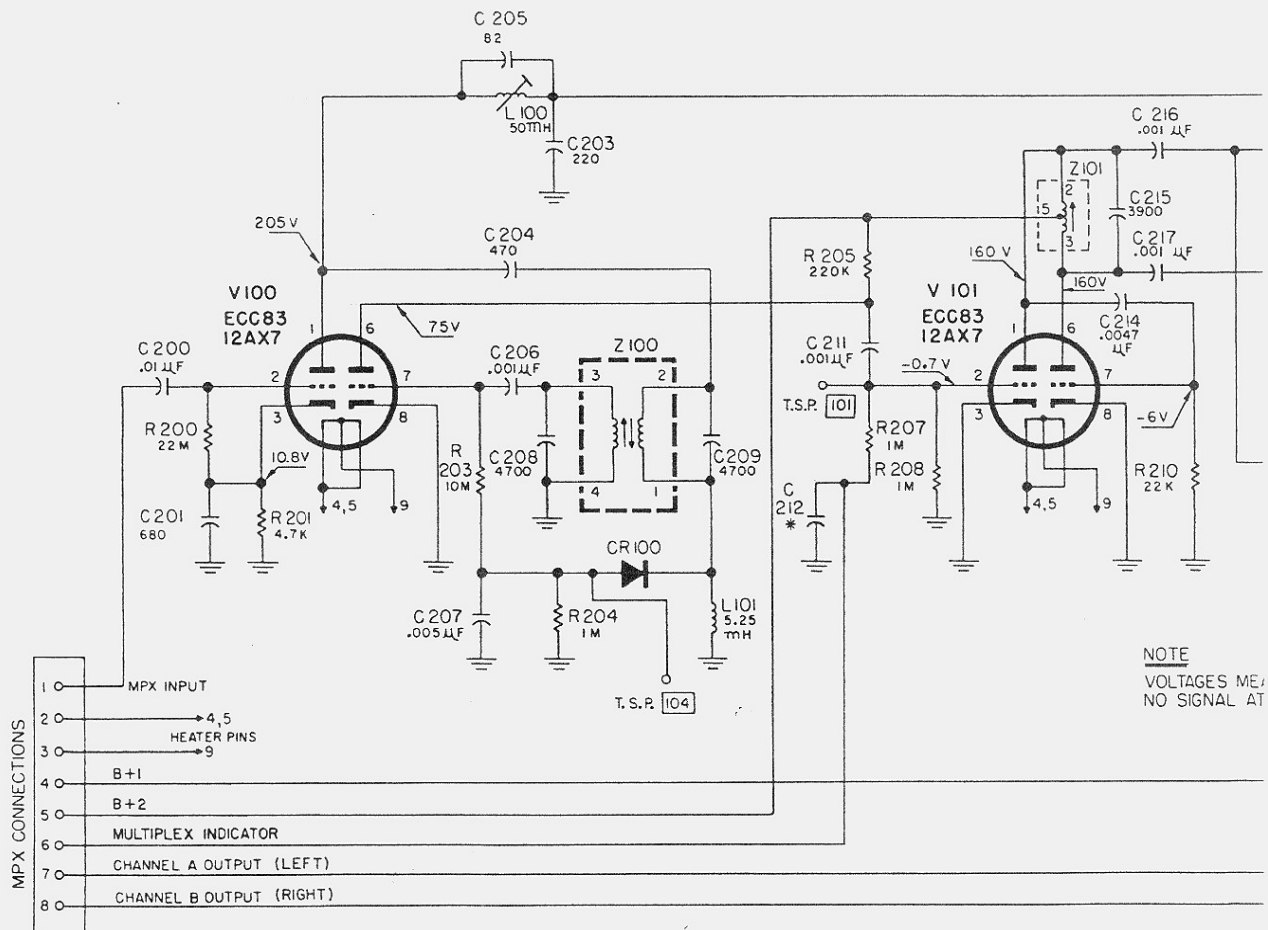

* SEE PARTS LIST

MULTIPLEX DECODER

C50089-1	R201	Composition, 4.7K, 1/2 W
C50073-2	R202	Composition, 15K, 1/2 W
C50197-25	R203	Composition, 10M, 10%, 1/2 W
C50332-6	R204	Dep. Carbon, 1M
C50089-2	R205	Dep. Carbon, 220K, 1/2 W
C50089-5	R206	-Deleted-
C50089-5	R207, 208	-Deleted-
C50197-52	209	Dep. Carbon, 1M
C50072-3	R210	Dep. Carbon, 22K
C50072-5	R211, 212	-Deleted-
	R213, 214	Dep. Carbon, 100K
	R215	Potentiometer, 50K, MPX Separation
	R216	Composition, 22M, 10%, 1/2 W
	R217, 218	Dep. Carbon, 18K, 1/2 W
	R219, 220	Dep. Carbon, 15K, 1/2 W
	R221	Composition, 22M, 10%, 1/2 W

RC20BF472J	R222, 223	Dep. Carbon, 27K
RC20BF153J	R224, 225	Dep. Carbon, 22K
RC20BF106K	R226, 227,	
R12DC105J	228, 229,	
R33DC224J	230, 231	Dep. Carbon, 1M

R12DC105J		
R12DC223J		

R12DC104J		
R50150-4		
RC20BF226K		
R33DC183J		
R33DC153J		
RC20BF226K		

R12DC273J
R12DC223J
R12DC105J

MISCELLANEOUS

Symbol	Description	Part No.
CR100	Diode, Type 1112	V1112
CR102, 103	Diode Bridge	V50260-13DX
L100	Coil, low pass	L50210-30
L101	Coil, 5.25MH	L50334-1
L102, 103	Coil, 20MH	L50334-2
Z100	Transformer, 19Kc	ZZ50210-34
Z101	Coil, 38Kc	ZZ50210-33

otherwise noted.

Part No.
RC20BF226K

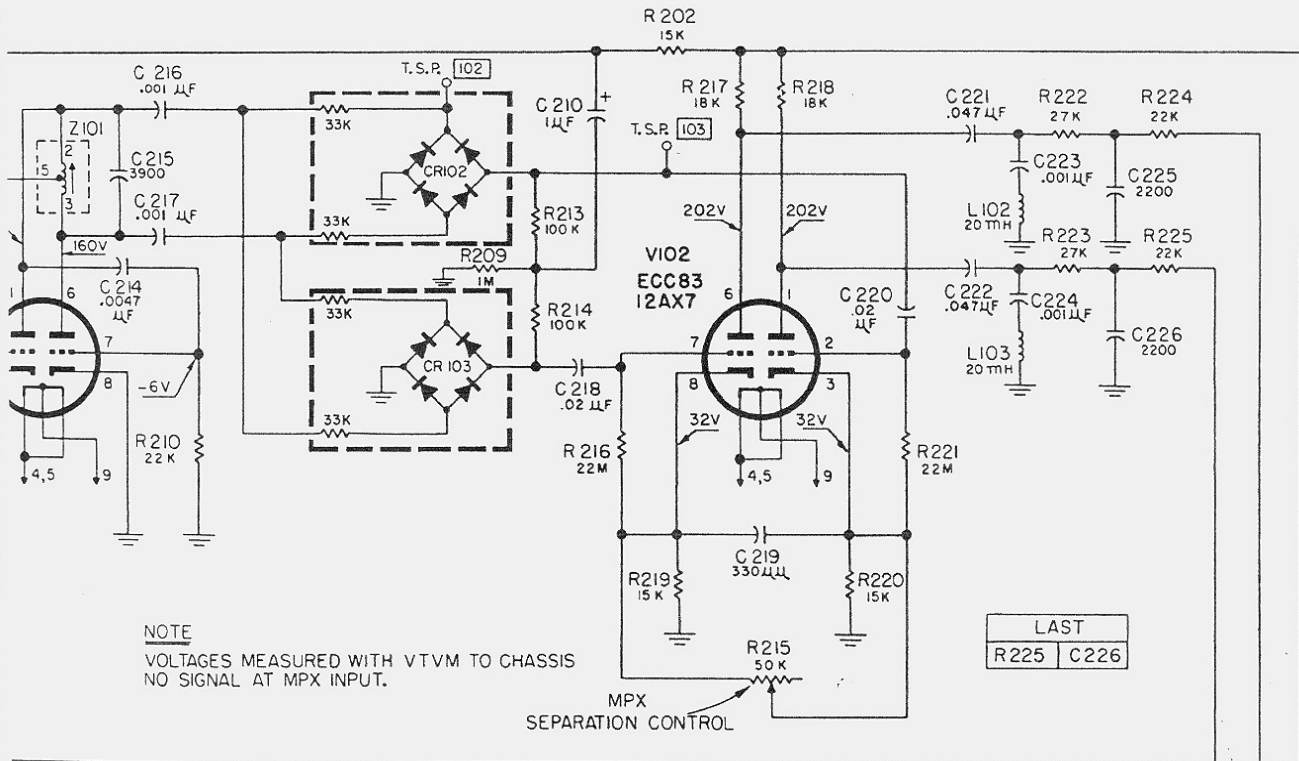

NOTE
VOLTAGES MEASURED WITH VTVM TO CHASSIS
NO SIGNAL AT MPX INPUT.

LAST
R225 C226

CAPACITORS

10% Tolerance for all fixed capacitors, unless otherwise marked or noted GMV (guaranteed minimum value). All capacitors not marked uF are pF (uF).

Symbol	Description	Part No.				
C1	Ceramic, 21, 5%, N750, 1000V	C50070-32	C41	Electrolytic, 8uF, 50V	C629-138	R41
C2	Ceramic, 8, 5%, NPO, 1000V	C50070-45	C42	Electrolytic, 100uF, 25V	C50483-6	R42
C3	Ceramic, Trimmer	C662-123	C43, 44	Ceramic, .02uF, +80 -20%, 500V	C50089-4	R44
C4	Ceramic, 1000GMV, 500V	C50089-2	C45, 46, 47, 48, 49, 50	Ceramic, 5000, +80 -20%, 500V	C50089-6	R45
C5, A, B, C	Variable, FM Tuning	C966-109-1	C51	-Deleted-	---	R47
C6	Ceramic, 39, N1500, 1000V	C50070-17	C52	Electrolytic, 4-Section	C50180-49	R49
C7	Ceramic, 24, 5%, N150, 1000V	C50070-8		A- 20uF, 300V		R51
C8	Ceramic, 1000, GMV, 500V	C50089-2		B- 40uF, 400V		R53
C9	Ceramic, 12, N080, 5%, 500V	CC20LJ120J5		C- 40uF, 450V		R55
C10	Ceramic, Trimmer	C662-123		D- 40uF, 500V		R57
C11	Ceramic, 8, 5%, NPO, 1000V	C50070-45	C53, 54, 55	-Deleted-	---	R59
C12	Ceramic, 13, NPO, 5%, 500V	CC20CJ130J5	C56	Electrolytic, 100uF, 300V	C50180-43	R61
C13	Ceramic, 120, 5%, N1500, 1000V	C50070-44	C57	Electrolytic, 3-Section	C50180-51	R63
C14, 15, 16, 17	Ceramic, Feedthru, 1000	C592-187		A- 50uF, 250V		R65
C18	Ceramic, .02uF, +80 -20%	C50095-1		B- 50uF, 250V		R67
C19	Ceramic, 2700, 1000V	C50072-17		C- 200uF, 300V		R69
C20	Ceramic, 560, 1000V	C50072-14	C58, 59	-Deleted-	---	R71
C21, 22	Ceramic, 5000, +80 -20%, 500V	C50089-6	C60	Electrolytic, 2-Section	C50180-38	R73
C23	Ceramic, 2700, 1000V	C50072-17		A- 1000uF, 35V		R75
C24	Ceramic, 5000, +80 -20%, 500V	C50089-6		B- 1000uF, 35V		R77
C25	Ceramic, 24, 5%, 1000V	C50070-8		-Deleted-	---	R79
C26	Ceramic, .02uF, +80 -20%, 100V	C50095-1	C61	-Deleted-	---	R81
C27	Ceramic, .02uF, GMV, 1000V	C50071-6	C62	Ceramic, Feedthru, 1000	C592-i87	R83
C28	Ceramic, 2700, 1000V	C50072-17	C63, 64	Molded, .01uF, 20%, 600V	C2747	R84
C29	Ceramic, .02uF, GMV, 1000V	C50071-6	C65, 66	Ceramic, 100 GMV, N1500, 1000V	C50070-5	R85
C30	Ceramic, 5000, +80 -20%, 500V	C50089-6	C67, 68	Ceramic, .01uF, 20%, 500V	C50089-3	R87
C31	Ceramic, 18, N470, 1000V	C50070-13	C69, 70	Mylar, .047uF, 400V	C50197-49	R89
C32	Mylar, .1uF, 125V	C50435-7	C71, 72	Ceramic, 120, N1500, 1000V	C50070-9	
C33	Ceramic, 1000, 1000V	C50072-3	C73	Ceramic, 18, N470, 1000V	C50070-13	
C34	Ceramic, .02uF, +80 -20%, 500V	C50089-4	C74	Ceramic, 24, 5%, 1000V	C50070-8	
C35	Ceramic, 2700, 1000V	C50072-17	C75, 76	Ceramic, 1000, 1000V	C50072-3	
C36	Ceramic, .02uF, GMV, 1000V	C50071-6	C77, 78	Ceramic, .02uF, 20%, 500V	C50089-4	
C37	Ceramic, 5000, +80 -20%, 500V	C50089-6	C79, 80	Ceramic, 56, 5%, N1500, 1000V	C50070-38	
C38	Ceramic, 1800, 1000V	C50072-8	C81, 82	Mylar, .047uF, 400V	C50197-30	
C39, 40	Ceramic, 330, 1000V	C50072-1	C83, 84	Ceramic, 560, 1000V	C50072-14	
			C85, 86	Ceramic, 68, N2200, 1000V	C50070-12	Syn
			C87, 88	Ceramic, .02uF, 20%, 500V	C50089-5	L1
			C89, 90	Ceramic, 2, NPO, 1000V	C50070-23	L2
			C91, 92	Ceramic, 560, 1000V	C50072-14	L3
			C93, 94	Mylar, .047, 630V	C50197-101	L4
			C95, 96	Mylar, .047, 400V	C50197-30	L5
			C97, 98	Ceramic, 18, N470, 1000V	C50070-13	L6
			C99, 100	Ceramic, 330, 1000V	C50072-1	

RESISTORS & POTENTIOMETERS

Deposited Carbon, in ohms, 5% Tolerance, 1/8 watt, unless otherwise noted. K=Kilohms, M=Megohms.

Symbol	Description	Part No.				
R1	Composition, 270, 10%, 1/2W	RC20BF271K	R17	2.2M, 1/3W	R33DC225J	
R2	Composition, 100K, 10%, 1/2W	RC20BF104K	R18	820K	R12DC824J	
R3	1.2K	R12DC122J	R19	Composition, 82K, 10%, 1/2W	RC20BF823K	Syn
R4	220K	R12DC224J	R20	15K	R12DC153J	CR
R5	150K	R12DC154J	R21	100K	R12DC104J	CR
R6	1K	R12DC102J	R22	3.3M, 1/3W	R33DC335J	F1
R7	Composition, 4.7K, 10%, 1/2W	RC20BF472K	R23	4.7M, 1/3W	R33DC475J	I1,
R8	Composition, 3.9K, 10%, 1W	RC30BF392K	R24	47K	R12DC473J	J20
R9	Composition, 68, 5%, 1/2W	RC20BF680J	R25	68K	R12DC683J	PC
R10	Composition, 27K, 10%, 1/2W	RC20BF273K	R26	470K	R12DC474J	PC
R11	39K	R12DC393J	R27	Composition, 270, 5%, 1/2W	RC20BF271J	PC
R12	Composition, 1K, 10%, 1/2W	RC20BF102K	R28	47K	R12DC473J	
R13	Composition, 150, 10%, 1/2W	RC20BF151K	R29	Composition, 1.5K, 5%, 1/2W	RC20BF152J	
R14	Composition, 47K, 10%, 1/2W	RC20BF473K	R30	Composition, 1K, 5%, 1/2W	RC20BF102J	
R15	Composition, 15K, 10%, 1/2W	R12DC153J	R31, 32	6.8K	R12DC682J	
R16	Composition, 68K, 10%, 1/2W	RC20BF683K	R33	Composition, 100K, 10%, 1/2W	RC20BF104K	
			R34	2.2K, 1/3W	R33DC222J	
			R35	1K, 1/3W	R33DC102J	
			R36, 37	Composition, 220, 10%, 1/2W	RC20BF221K	
			R38	Composition, 22K, 10%, 1/2W	RC20BF223K	
			R39	Composition, 2.2K, 10%, 1W	RC30BF222K	
			R40	Composition, 1.2K, 10%, 1W	RC30BF122K	

SSIS • PARTS DESCRIPTION LIST

38	R41	Glass, 1.2K, 10%, 7W	RPG7W122K	R91, 92	2.7M, 1/3W	R33DC275J
-6	R42, 43	Glass, 330, 10%, 3W	RPG3W331K	R93, 94	47K	R12DC473J
-4	R44	Composition, 820K, 10%, 1/2W	RC20BF824K	R95	Pot., 500K, Balance	R50160-135
	R45, 46	220K	R12DC224J	R96, 97	22K	R12DC223J
-6	R47, 48	150K	R12DC154J	R98A, B	Pot., 500K, Dual, Volume	R50160-104
	R49, 50	68K	R12DC683J	R99, 100	47K	R12DC473J
-49	R51, 52	100K	R12DC104J	R101, 102	390K	R33DC394J
	R53, 54	10	R12DC100J	R103, 104	1.2K	R12DC122J
	R55, 56	10K	R12DC103J	R105, 106	220	R12DC221J
	R57, 58	Glass, 2.7K, 5%, 1/2W	R20G272J	R107, 108	Potentiometer, 500K	R50150-6
	R59, 60	Glass, 330K, 5%, 1W	R30G334J	R109, 110	47K, 1/3W	R33DC473J
	R61, 62	4.7M, 1/3W	R33DC475J	R111, 112	120K, 1/3W	R33DC124J
-43	R63, 64	220K, 1/3W	R33DC224J	R113, 114	2.7K	R12DC272J
-51	R65, 66	330K	R12DC334J	R115, 116	150K, 1/3W	R33DC154J
	R67, 68	82K	R12DC823J	R117, 118,		
	R69, 70	330K	R12DC334J	119, 120	330K	R12DC334J
	R71, 72	470K	R12DC474J	R121, 122,		
	R73, 74	1.5M, 1/3W	R33DC155J	123, 124	1K, 1/3W	R33DC102J
-38	R75, 76	2.7M, 1/3W	R33DC275J	R125	4.7K, 1/3W	R33DC472J
	R77, 78	120K, 1/3W	R33DC124J	R126, 127	Wirewound, 25, 10%, 5W	R688-117
	R79, 80	1K	R12DC102J	R128, 129	2.2K, 1/3W	R33DC222J
	R81, 82	680K	R12DC684J	R130, 131	Composition, 330, 10%, 1/2W	RC20BF331K
-7	R83A, B	Pot., 500K, Dual, Treble	R50160-136-1	R132, 133	470K	R12DC474J
	R84A, B	Pot., 500K, Dual, Bass	R50160-136-2	R134, 135	Composition, 1K, 10%, 1/2W	RC20BF102K
5	R85, 86	120K, 1/3W	R33DC124J	R136	470K	R12DC474J
3	R87, 88	1K	R12DC102J	R137	Composition, 1.8M, 10%, 1/2W	RC20BF185K
49	R89, 90	220K	R12DC224J	R138	Wirewound, 15, 10%, 5W	R719-106

COILS, CHOKES, TRANSFORMERS

Symbol	Description	Part No.	Symbol	Description	Part No.
L1	Coil, FM Antenna	L966-113	L7	Choke, 3.3 Microhenry	L50066-8
L2	Coil, RF	L1034-113	T1	Transformer, Power	T1020-124
L3	Coil, FM Mixer	L1034-112	T2	Transformer, Output	T1020-116-1AX
L4	Coil, FM Oscillator	AS1034-115	T3	Transformer, Output	T1020-116-2AX
L5	Choke, 1.2 Microhenry	L50066-3	Z1	Transformer, FM IF	ZZ50210-20
L6	Choke, .68 Microhenry	L50066-1	Z2	Transformer, FM IF	ZZ2987
			Z3	Transformer, FM IF	ZZ50210-2
			Z4	Coil, FM Limiter	ZZ50210-61
			Z5	Transformer, FM Ratio Detector	ZZ50210-9

MISCELLANEOUS

Symbol	Description	Part No.	Symbol	Description	Part No.
CR1	Rectifier, Silicon Bridge	SIB50B794-2	S1	Switch, Selector	S1020-119
CR2, 3	Diode, Silicon	SR50411-1	S2, 3, 4, 5	Switch, Slide	S50200-5
F1	Fuse, 3.2 AMP, Slo-Blo	F3319	S6	Switch, Power	Part of R98
I1, I2	Lamp, Dial	I50411-4	--	Dress. Panel, Screened	AS1020-108
J20	Jack, Earphone	J846-120-1	--	Antenna, FM Dipole	AS50227-1
PC1, 2	Printed Circuit, Equalization	PC50187-3	--	Knob, Dummy Dual	E50324
PC3, 4	Printed Circuit, Tone Control	PC50187-9	--	Knob, Dual, Top	E50323
PC5, 6	Printed Circuit, High Filter	PC50187-2	--	Knob, Dual, Bottom	E50221
			--	Knob, Tuning	E50324-1
			--	Dial Glass, Screened	N1020-107
			--	Fuse Holder	X563-151

75J
24J
323K
33J
04J
35J
75J
73J
83J
74J
271J
73J
152J
102J
32J
104K
22J
32J
221K
223K
222K
122K

RECEIVER • SCHEMATIC

SWITCH POSITIONS						
POS NO	S1 SELECTOR SW	S2 TAPE MONITOR SW	S3 HIGH FILTER SW	S4 LOUDNESS CONTROL SW	S5 SPEAKER SW	S6 POWER SW
1	TAPE HEAD	OFF	OFF	OFF	OFF	OFF
2	PHONO NORM	ON	ON	ON	ON	ON
3	PHONO STEREO					
4	FM STEREO					
5	FM STEREO FILTER					
6	FM MONO					
7	AUX TAPE					

ALL SWITCHES ARE SHOWN IN THE NO. 1 POSITION.

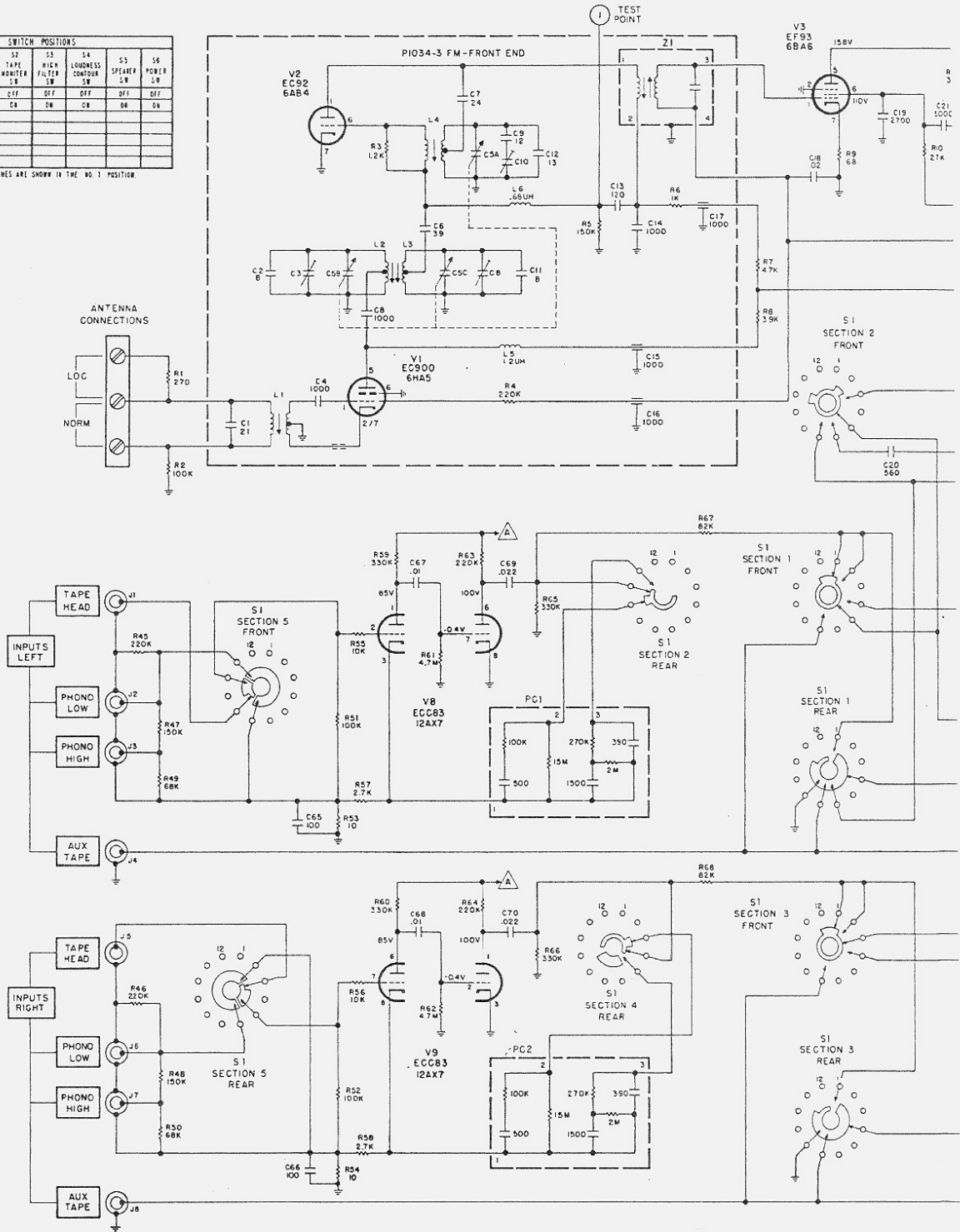

BECAUSE ITS PRODUCTS ARE SUBJECT TO CONTINUOUS IMPROVEMENT, FISHER RADIO CORPORATION RESERVES THE RIGHT TO MODIFY ANY DESIGN OR SPECIFICATION WITHOUT NOTICE AND WITHOUT INCURRING ANY OBLIGATION.

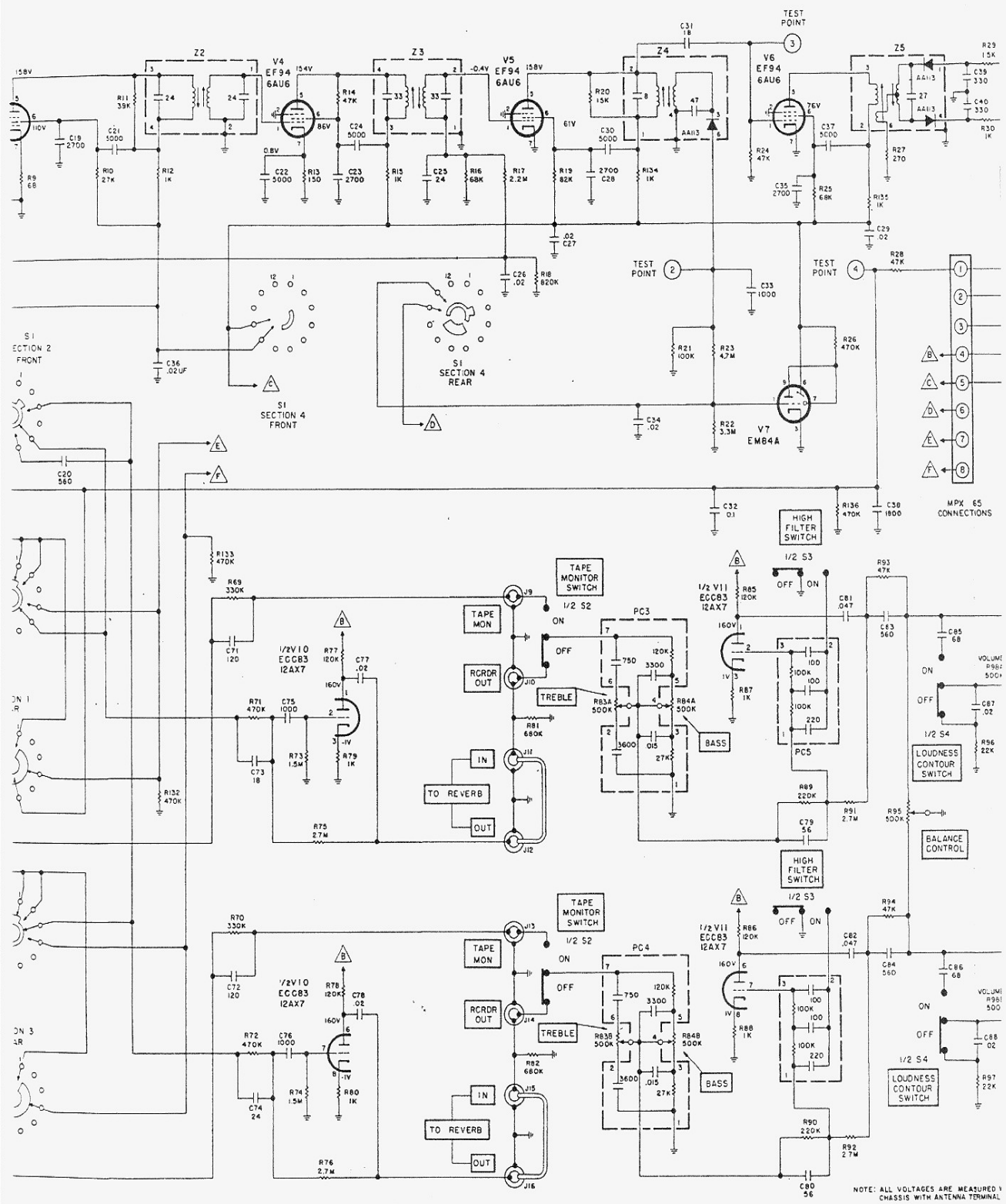

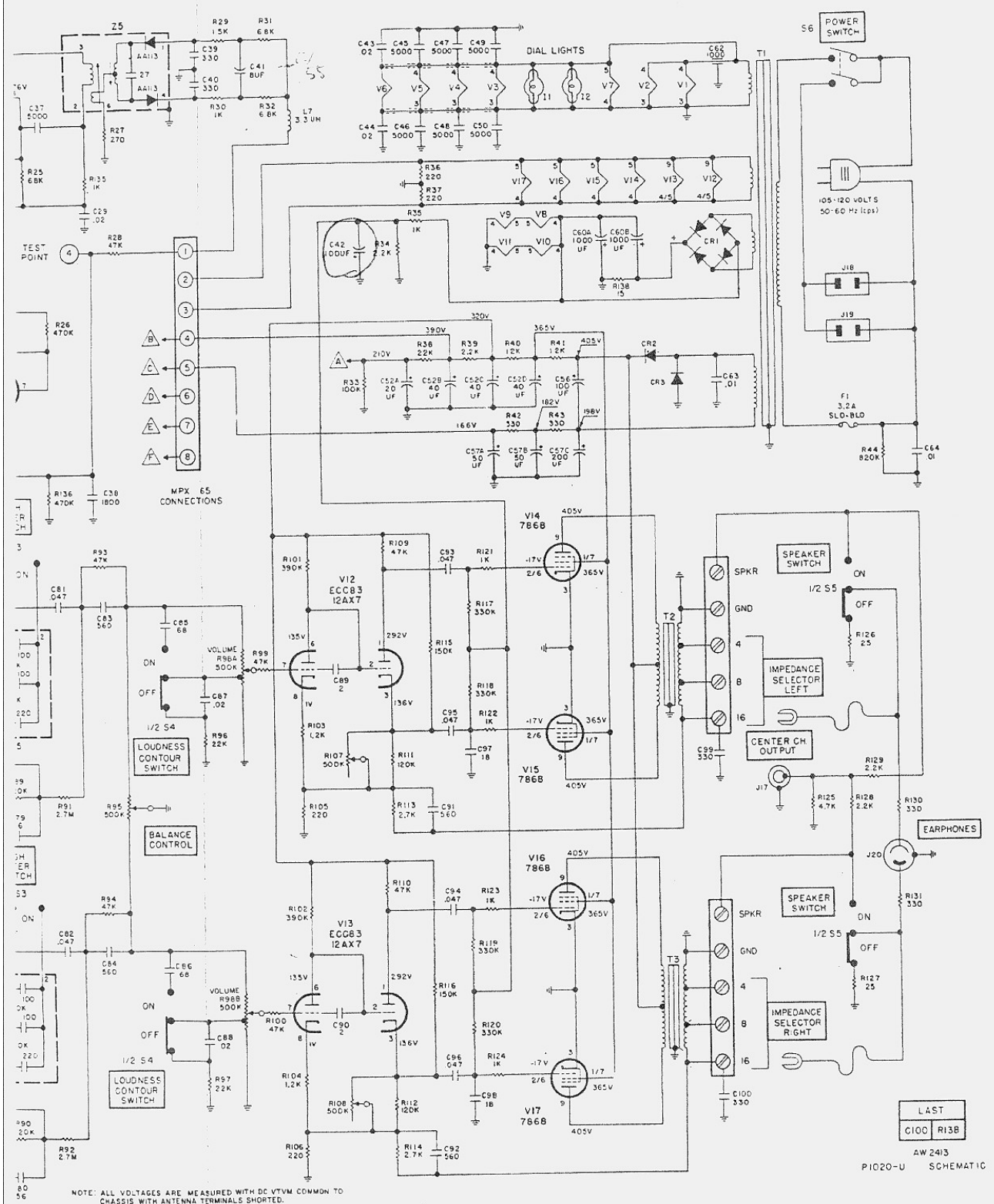

NOTE: ALL VOLTAGES ARE MEASURED WITH DC VTVM COMMON TO CHASSIS WITH ANTENNA TERMINALS SHORTED.

LAST
C100 R13B

AW 2413
PI020-U SCHEMATIC

ALIGNMENT INSTRUCTIONS

- Set the SELECTOR switch to the MONO position for the entire alignment procedure.
- Rotate the TUNING knob to its maximum counterclockwise position. (Dial pointer must line up with the zero (0) calibration mark at the left-hand end of the logging scale without forcing—reset dial pointer if necessary.)
- Warm up the receiver and the test equipment for at least 15 minutes before beginning alignment.
- Adjust the line voltage for 117-volts, 50- to 60-Hz (cps) AC.

WARNING: Only use the proper, fully insulated, alignment tools to prevent breakage or damage to the adjustable circuit components.

NOTE: Reduce signal-generator output during alignment to keep VTVM readings below the specified voltages.

STEP	DIAL	SIGNAL GENERATOR			DC VTVM	ADJUST	INDICATION
		GENERATOR COUPLING	FREQ.	MOD.			
1	Set dial pointer for extreme C.C.W. position.	Ungrounded tube shield of V2	10.7 MHz (MC)	None	TEST POINT 3	Z1, Z2, Z3 top and bottom; Z4 bottom	Maximum negative voltage (below -5 volts)
2					---	Z4 top	Maximum indication on TUNING INDICATOR
3					Across C41	Z5 bottom	Maximum indication (below -20 volts)
4					Hot lead of DC VTVM to TEST POINT 4; Common lead to ground	Z5 top	Zero indication on zero-center dial.
5	90 MHz (MC)	Two 120-ohm carbon resistors in series with generator leads to the Normal antenna terminals.	90 MHz (MC)	± 22.5 kHz (KC) deviation at 400 cps	Through 100K resistor to TEST POINT 2	L4, L3 and L2	Adjust for maximum negative voltages and check for sine wave-form, with scope at Left or Right RCRDR output.
6	106 MHz (MC)		106 MHz (MC)	± 22.5 kHz (KC) deviation at 400 cps	Through 100K resistor to TEST POINT 2	C10, C8 and C3	
7	98 MHz (MC)		98 MHz (MC)	± 22.5 kHz (KC) deviation at 400 cps	Through 100K resistor to TEST POINT 2	L1	
8	Repeat steps 6 and 7 for proper dial calibration and maximum output.						

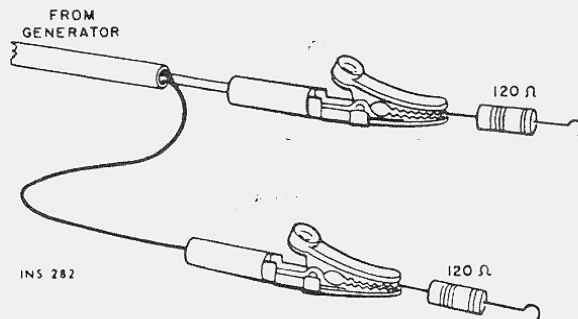

CHASSIS LAYOUT

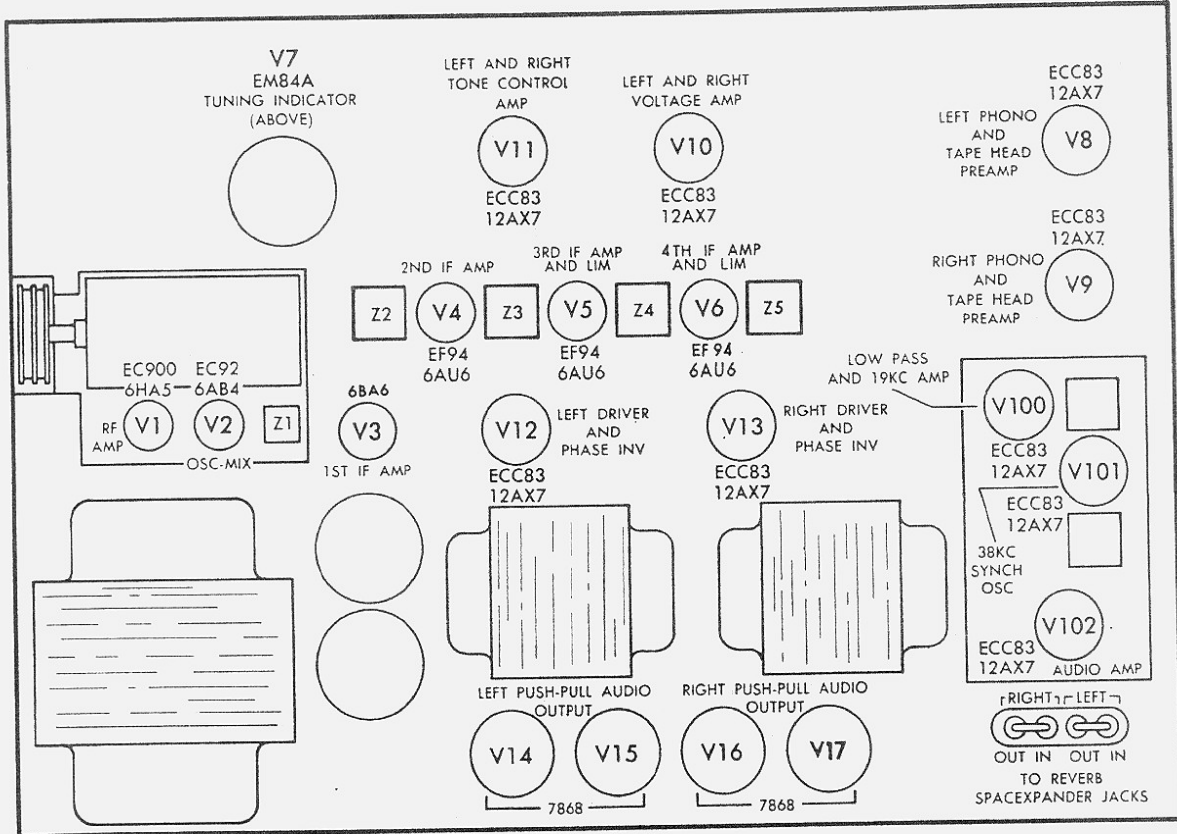

NOTE: IMPEDANCE SELECTOR SHOWN IN 16-OHM CONNECTION

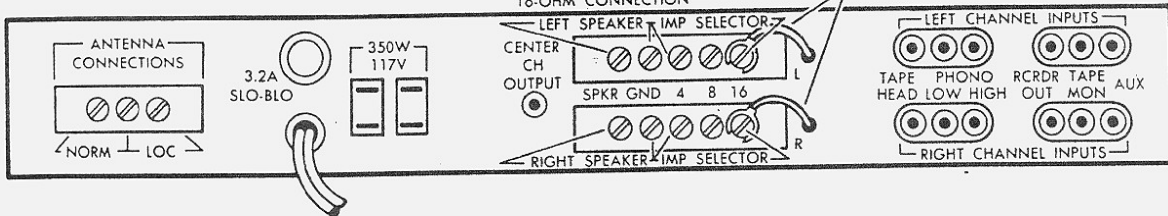

INS 174A



FISHER RADIO CORPORATION · NEW YORK

MI 020-105 GX

PRINTED IN U.S.A.

110M