

SERVICE MANUAL

PRICE \$1.00

401

SERIAL NUMBERS
BEGINNING 50001

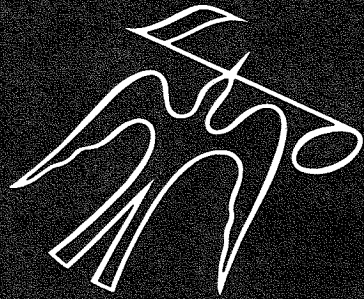

The Fisher[®]

401[™]



WORLD LEADER IN HIGH QUALITY STEREO

TEST EQUIPMENT AND SERVICE TIPS

The following equipment is required to completely test and align modern high-fidelity amplifiers, tuners, and receivers.

Line Voltage Autotransformer or Voltage Regulator	10.7 MHz Sweep Generator
DC Vacuum Tube Voltohmmeter	Multiplex Generator (preferably with RF output)
Accurately Calibrated AC Vacuum Tube Voltmeter	455 kHz Sweep Generator
Oscilloscope ((Flat to 100 kHz Minimum)	Ferrite Test Loop Stick
Low-Distortion Audio (Sine Wave) Generator	2 – Full Range Speakers for Listening Tests
Intermodulation Distortion Analyzer	Stereo Source – Turntable, Tape Recorder, etc.
Harmonic Distortion Analyzer	Soldering Iron with Small Tip, Fully Insulated from AC Line
2 – Load resistors, 8-Ohms, 100 Watt (Minimum Rating)	Suction Desoldering Tool
AM/FM Signal Generator	

CAUTION: This precision high-fidelity instrument should be serviced only by qualified personnel, trained in the repair of transistor equipment and printed circuitry.

Many of these items are included only as a reminder — they are normal procedures for experienced technicians. Shortcuts may be taken, but these often cause additional damage to transistors, circuit components, or printed circuit boards.

SOLDERING: A well-tinned, hot, clean soldering iron tip will make soldering easier, without causing damage to the printed circuit board or the components mounted on it. Regular use of a sponge cleaner will maintain a clean soldering surface. The heat available at the tip, (not the wattage of the iron) is important. Some 50-watt irons reach temperatures of 1,000° F, while others will hardly melt solder. Small-diameter tips should be used for single solder connections, pyramid and chisel tips for large areas.

Always disconnect the AC power cord from the line when soldering. Turning the power switch OFF is not sufficient. Power-line leakage paths, through the heating element of the iron, may destroy transistors.

PARTS REMOVAL: If a part is not being returned for in-warranty factory replacement, it may be cut in half (with diagonal cutting pliers) to make removal easier. Multiple terminal parts, such as IF transformers, or electrolytic capacitors, should be removed using special de-soldering tips made especially for this purpose. Removing solder from terminals, reduces the possibility of breaking the printed circuit board when the part is removed.

ACCIDENTAL SHORTS: A clean working area, free of metal particles, screws, etc., is an important preventive in avoiding servicing problems. Screws, removed from the chassis during servicing, should be stored in a box until needed. While a set is operating, it takes only an instant for a base-to-collector short to destroy a transistor (and others direct-coupled to it). In the time it takes for a dropped machine screw, washer, or screwdriver, to contact a pair of socket terminals (or terminal and chassis), a transistor can be ruined.

SOLID-STATE DEVICES: Integrated Circuits contain the equivalent of many circuit parts, including transistors, diodes, resistors, and capacitors. The preferred troubleshooting procedure requires isolating the trouble to one stage using AC signal tracing methods. Once the suspected stage is located, the DC voltages at the input and output leads are measured to give an accurate indication of the operating conditions of the IC. DO NOT use an ohmmeter to check continuity with the IC mounted on the printed circuit board. Forward biasing the internal junctions within the IC may burn out the transistors. Do not replace a defective IC until all external resistors, capacitors, and transformers are checked first, to prevent the replacement IC from failing immediately due to a defect in the connecting components. Solder and unsolder each lead separately using a pliers or other heat sink on the lead to prevent damage from excessive heat. Check that the leads are

connected to the correct locations on the printed circuit board before turning the set on.

Whenever possible, a transistor tester should be used to determine the condition of a transistor or diode. Ohmmeter checks do not provide conclusive data, and may even destroy the junction(s) within the device.

Never attempt to repair a transistor power amplifier module until the power supply filter-capacitors are fully discharged.

If an output or driver transistor becomes defective (opens or shorts), always check ALL direct-coupled transistors and diodes in that channel. In addition, check the bias pot., and other parts in the bias network, before installing replacement transistors. All output and driver transistors in one channel may be destroyed if the bias network is defective. After parts replacement, always check the bias adjustment for specified idling current.

In some applications, replacement of transistors must be made from the same beta group as the original type. The beta group is indicated by a colored marking on the transistor. Be sure to include this information when ordering replacement transistors.

When mounting a replacement power transistor, be sure the bottom of the flange, mica insulator, and the surface of the heat sink, are free of foreign matter. Dust and grit will prevent flat contact, reducing heat transfer to the heat sink. Metallic particles can puncture the insulator, cause a short, and destroy the transistor.

Silicone grease must be used between the transistor and the mica insulator, and between the mica and the heat sink, for best heat transfer. Use Dow-Corning DC-3, or an equivalent compound made for power transistor heat conduction.

Use care when making connections to speakers and output terminals. To reduce the possibility of shorts, lugs should be used on the exposed ends, or stranded wire should be tinned to prevent frayed wire ends. Current in the speakers and output circuitry is quite high — poor contacts, or small sized wire, can cause significant power losses in the system. For wire lengths greater than 30 feet, 16 AWG, or heavier, should be used.

VOLTAGE MEASUREMENTS: All voltages are measured with the line voltage adjusted to 120 volts. All measured voltages are $\pm 10\%$. DC voltages are measured to ground with a VTVM, with no signal input unless otherwise noted. AC signal voltages are measured under the conditions specified on the schematic.

ALIGNMENT PROCEDURES: DO NOT attempt realignment unless the required test equipment is available, and the alignment procedure is thoroughly understood.

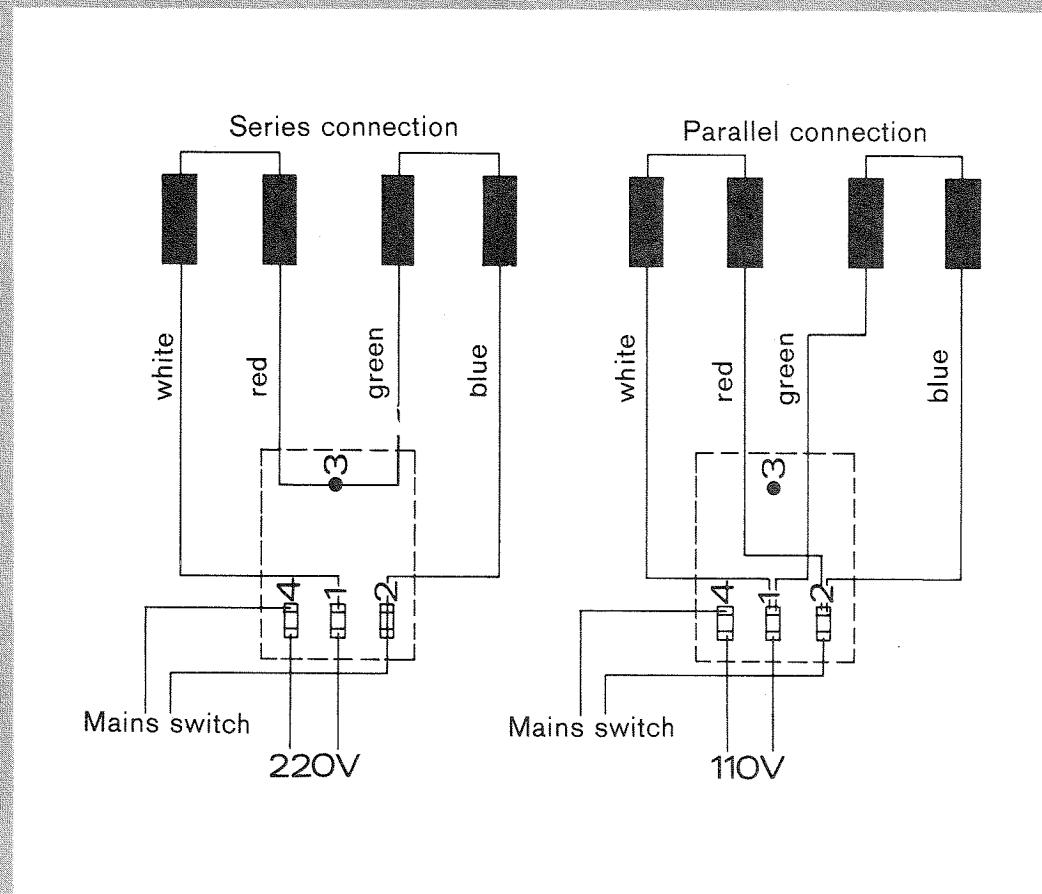

Wiring diagram for motor SPM 4/15

In the case of 220 volts, connect the motor by connecting the two associated windings in series. In the case of 110 volts, the two windings are to be connected in parallel.

Exchanging the lift rod

The lift rod (38) is only accessible after the tonearm with the entire bracket has been removed. Refill the silicone grease at the lift rod only when absolutely necessary. Take care to see that only a minimum quantity of silicone grease is applied to the lift rod. Also make sure that the drawspring (39) is hooked back to the lift rod (38).

Exchanging the control cam

After loosening the retaining screws (28) for the turntable bearing and taking out the nut (156), the control cam can be lifted up and out. It should be noted that for this purpose the feed lever (180) and the actuator (134) must be disengaged from the control cam.

Replacing the tonearm

The tonearm is to be replaced completely, together

with the bearing frame (46). After removing the cap (49), turn back the bearing screw (50) until the tonearm can be lifted out of the ball-bearing. Before removing the tonearm, unsolder the pickup lead from the short-circuiter and unhook the drawspring for the stylus pressure (60) from the antiskating subassembly by means of a bent wire. The drawspring for the stylus pressure (60) is hooked to the antiskating subassembly below the chassis plate in the tonearm bracket. To provide easy access to the spring, adjust the stylus pressure by means of the adjusting knob (62).

When installing the tonearm, care must be taken to see that the seven steel balls in the bearing frame (46) are embedded in Apex grease. Minimum possible friction of the bearing must be assured. A special screwdriver permits adjustment of the bearing screw (50) through the cap.

When exchanging the tonearm with the complete bearing, including the antiskating device, take care to see that the ball races for the tonearm bearing (63) are clean, free from dust and provided with Abrol oil when they are installed. The friction of this bearing must be adjusted with particular care. Tighten the hexagon nut 5.8 (67) by means of a special wrench until the desired friction is obtained. When hooking back the antiskating spring (70), make certain that it is replaced in the correct position and without any change.

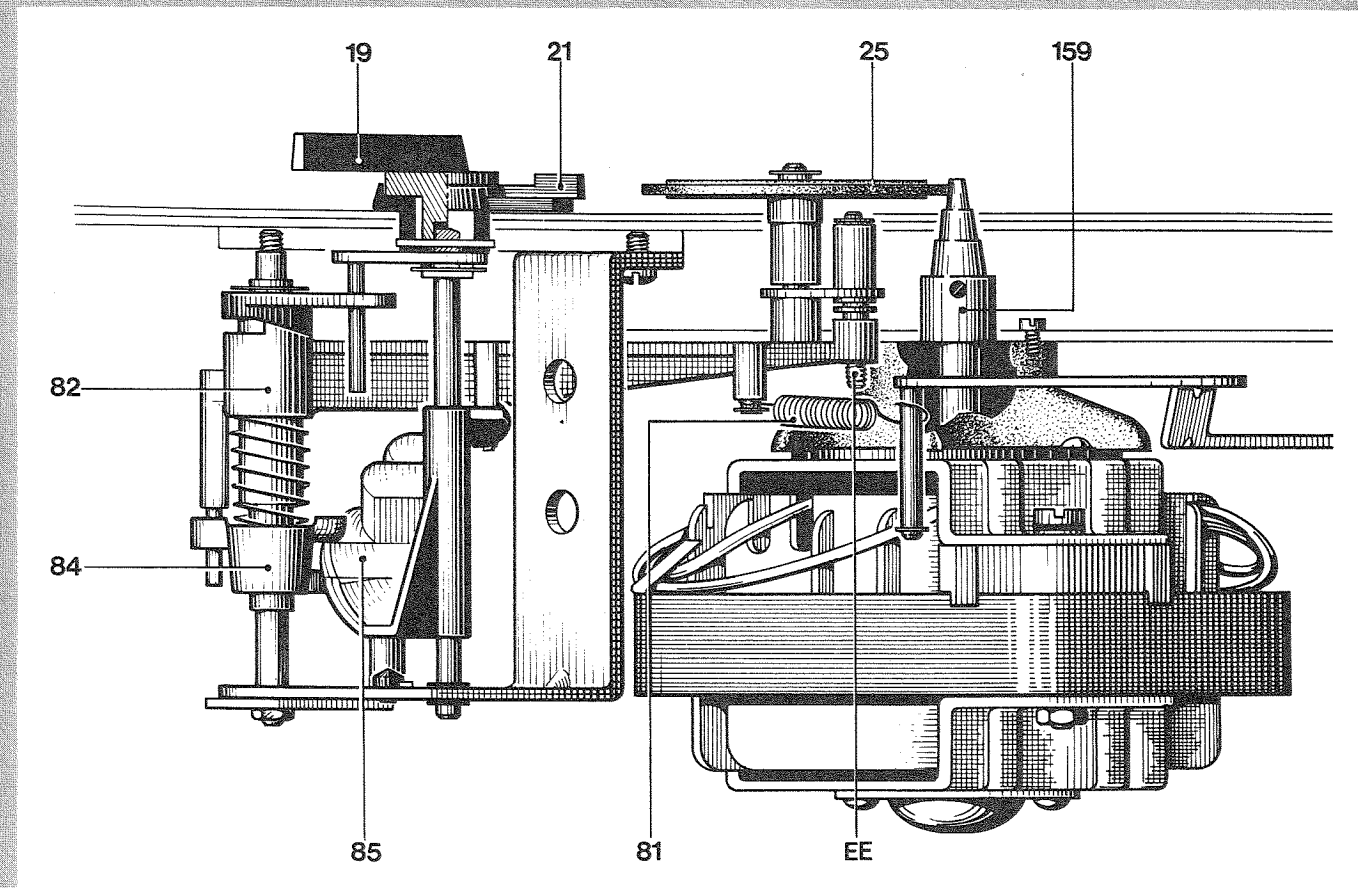

Item No.	Description
19	Speed selector knob
21	Setting lever
25	Idler wheel
81	Drawspring for idler wheel
82	Idler wheel support
84	Shift fork subassembly
85	Speed selector cam
159	Motor pulley
EE	Pivot pin

Speed control

The turntable speed is selected by means of a speed selector knob (19) that is rigidly united with the speed selector cam (85). The speed selector cam (85) moves the idler wheel support (82) to the correct height with respect to the motor pulley (159).

Speed precision control

This adjustment can be made at any speed. A setting lever (21) provided below the speed selector knob (19) moves the idler wheel support (82). The three steps of the step pulley (159) corresponding to the three turntable speeds are tapered. With the setting lever in mid-position of the \pm scale, adjust the precise speed by turning the pivot pin (EE).

Tonearm movement

The rising portion of the cam track of the control cam (150) causes the feed lever (180) to lift the tonearm (42) by means of the lift rod (38). At the same time, the tonearm (42) is frictionally engaged and is then moved by the succeeding horizontal movement of the feed lever (180). Down the descending portion of the cam track, the tonearm (42) is lowered and disengaged from the feed lever (180).

Control lever

Movement of the control lever (74) operates the starting lever (128) through a brass switching roller (109) that is mounted on the control lever bottom assembly (108). The starting lever (128) frees the ON/OFF switch (112) so that the motor (162) is connected to electric power and starts running. The idler wheel (25) is, at the same time, pressed against the drive shaft (159) of the motor (162) and also against the inside rim of the turntable. The control lever (74) releases the spring-loaded ratchet lever (123) which is thus allowed to advance the reject lever. The cam of the spinning turntable (5) engages the advanced tip of the reject lever. The control cam (150) is thereby turned to such an extent that the pinion of the turntable meshes with the tothing of the control cam (150). Following one control operation, all the control elements are moved to the position required for the following function.

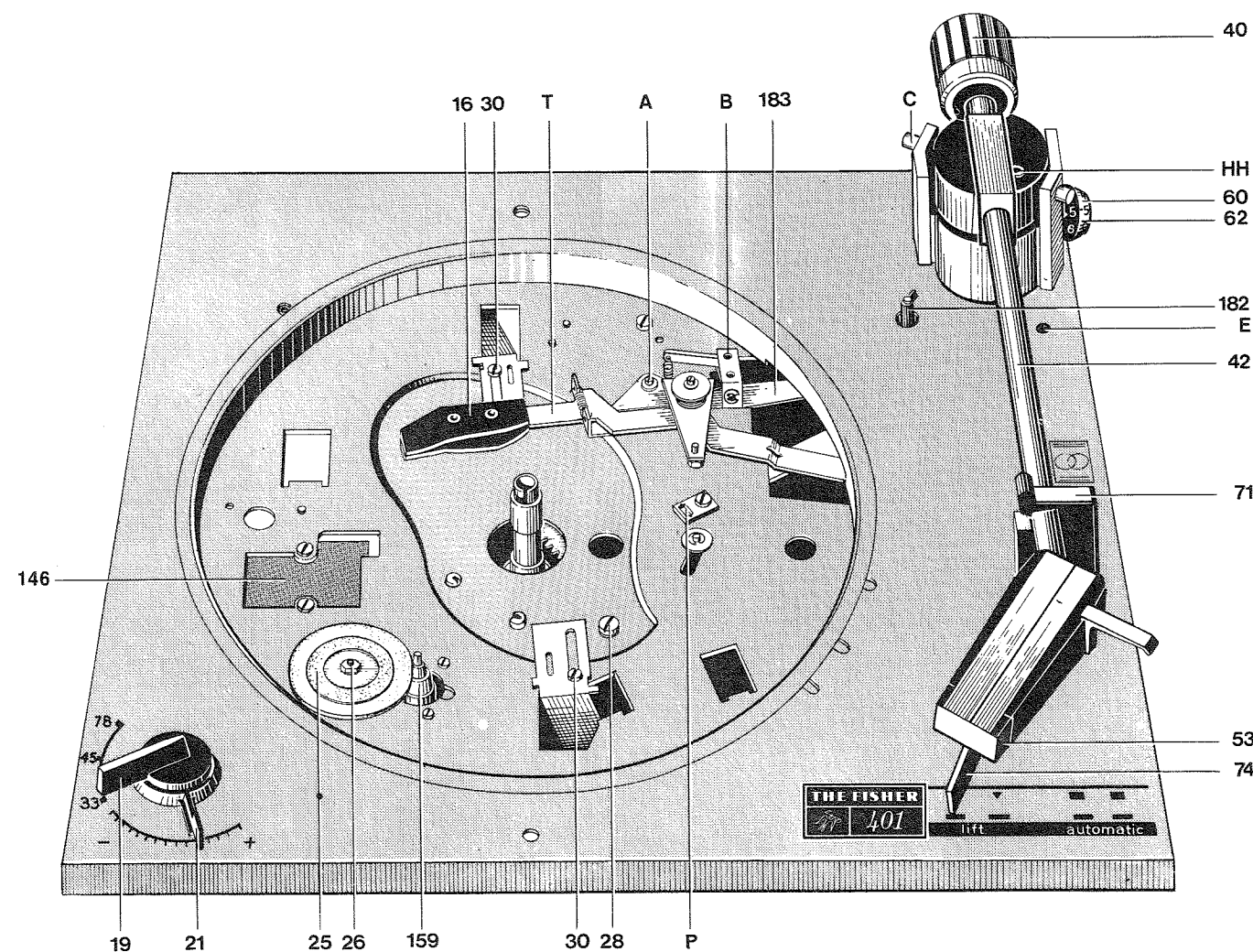
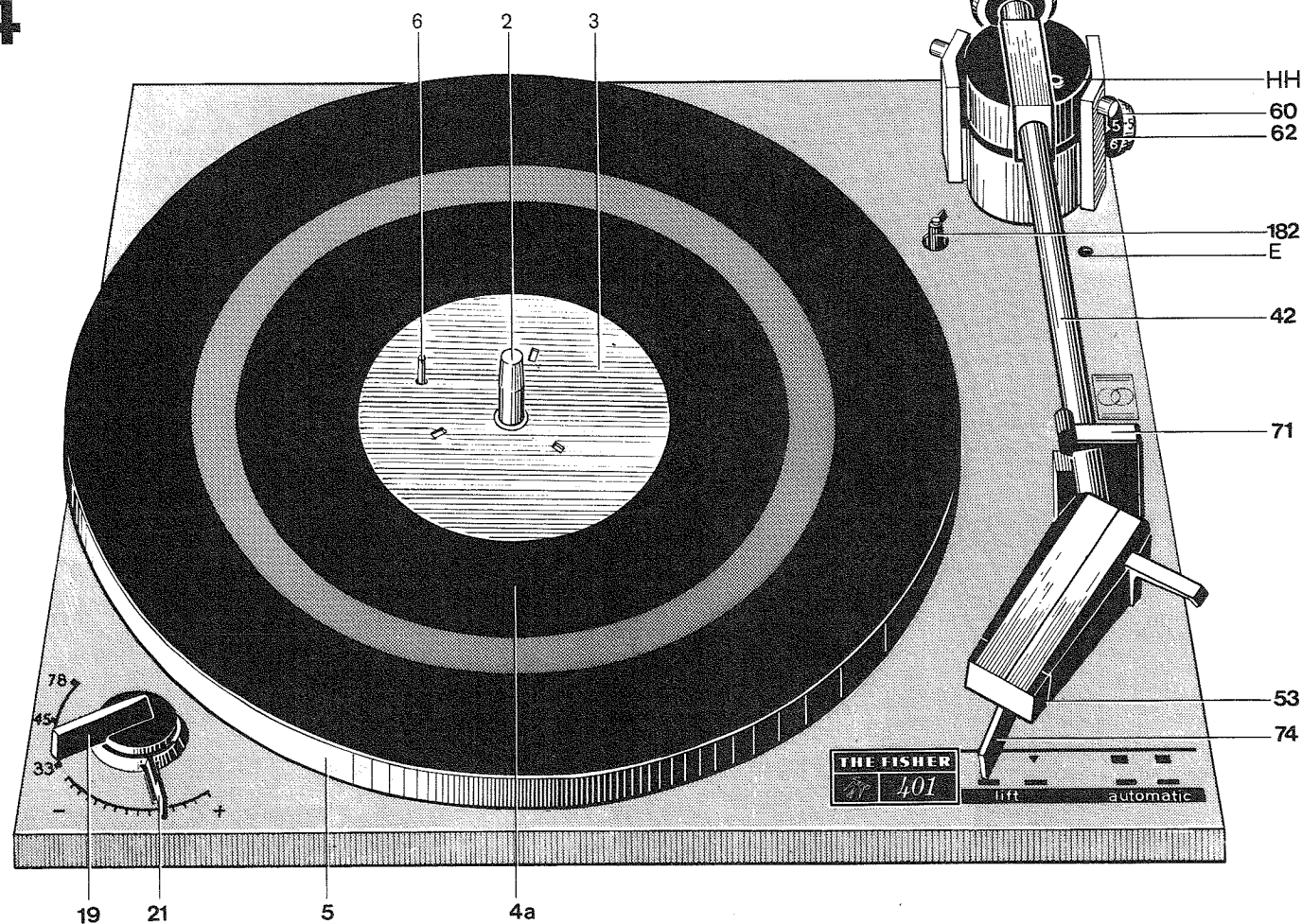

Item No.	Description
2	Single-play spindle
4 a	Turntable matting
5	Cast metal turntable platter
6	Feeler pin
19	Speed selector knob
21	Setting lever
40	Tonearm counterweight
42	Tonearm
53	Slide carrier assembly
60	Graduated dial
62	Tonearm tracking weight adjustment knob
71	Tonearm lock
74	Upper control lever assembly
182	Sensing pin
HH	Stylus pressure adjustment screw
E	Landing point

Record size discrimination
 The upper locating lever (16) as controlled by the control cam (150) is moved inside the operating range of a feeler pin (6) rotating with the turntable. Depending on the size of the record, the feeler pin (6) is pressed down to a greater or lesser extent. The level of that pin controls the different distance by which the locating lever (16) is restored for the inward movement of the tonearm (42) to its position above a 7" or 10" record. In the presence of a 12" record, the upward movement of the sensing lever (183) as released by the control cam (150) is limited. The upper locating lever (16) is locked during its return movement and thus reduces the inward movement of the tonearm (42) to the starting grooves of the 12" record.

Tripping
 As the tonearm (42) moves towards the center of the record, the trip link (117), which is supported on the tonearm locator segment (114), impels the reject lever towards the turntable cam. After the stylus has reached a record diameter of about $4\frac{23}{32}$ " (120 mm), the reject lever touches the rotating cam for the first time and is repelled by the latter until the lead-out groove with its higher pitch causes the reject lever to be engaged by the cam of the turntable (5), thus starting the control cam (150).

Record dropping
 The control cam (150) operates the drop lever (97) for the control of the automatic record spindle (1). As the push rod extension (164) is pulled down, the supporting levers are retracted to release the record which is thus dropped on the rotating turntable.

Item No.	Description
19	Speed selector knob
21	Setting lever
40	Tonearm counterweight
42	Pickup head with tonearm tube
62	Adjusting knob
71	Tonearm lock
74	Upper control lever
16	Upper locating lever tip
53	Slide carrier assembly
25	Idler wheel
26	Washer for idler wheel
30	Fillister head screw 3 x 5
28	Fillister head screw 4 x 8
146	Insulating clamp
159	Motor pulley
182	Sensing pin
183	Sensing lever
A	Locating lever eccentric
B	Bearing bracket for sensing lever
C	Tonearm pivot screw adjustment
E	Landing point
P	Trip link guide
T	Upper locating lever
HH	Stylus pressure adjustment screw

Automatic shut-off
 After the last record has been played, the tonearm (42) returns to the tonearm rest (72) and is not moved inward again. Because of the absence of records, the final shut-off is initiated inside the automatic record spindle (1). This has the effect that the stop switch (151) on the control cam (150) is no longer operated by the shut-off lever (102). Due to the unchanged position of the stop switch (151), the feed lever (180) is directed into the shut-off track of the control cam (150). In the course of the shut-off procedure, the idler wheel (25) is withdrawn from the motor pulley (159) and the inside rim of the turntable, and the record player is disconnected from mains power.

Automatic single-play
 By inserting the single-play spindle (2), the record changer becomes a fully automatic single-play record player. Depending on the size of the record, the tonearm lands within the standardized area of the lead-in grooves as in the case of changer operation.

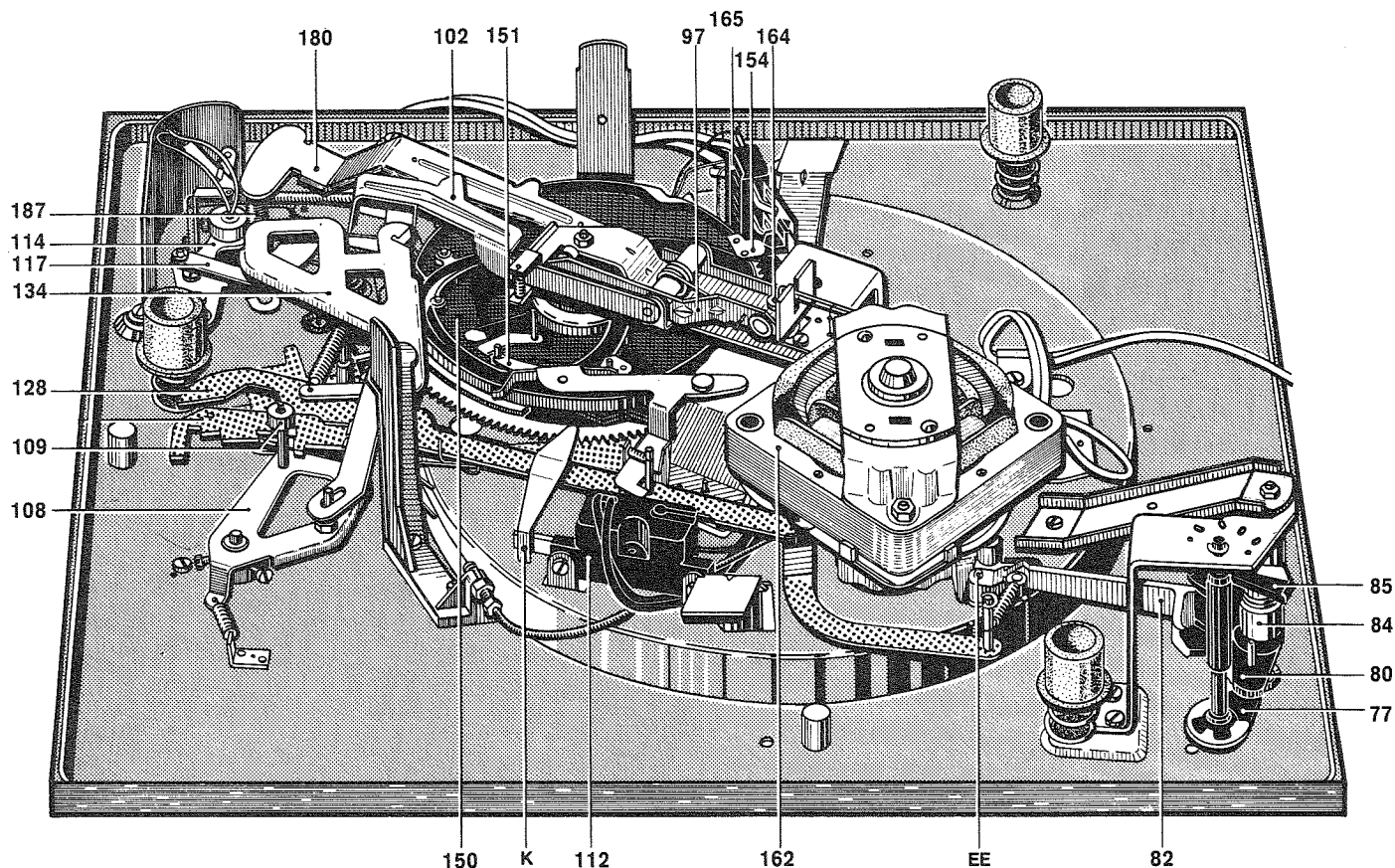

Item No.	Description
77	Lower locating lever
80	Adjusting arm
82	Idler wheel support
84	Shift fork
85	Speed selector cam
164	Push-rod extension
97	Drop lever
102	Shut-off lever
162	Shaded-pole motor
150	Control cam
151	Stop switch
154	Shorting cam
165	Short-circuiter
180	Feed lever
187	Guide sleeve
108	Control lever bottom assembly
109	Switching roller
112	ON/OFF switch
114	Tonearm locator segment
117	Trip link
128	Starting lever
134	Actuator
EE	Idler wheel height
K	Switch operating lever

Manual single play

When moving the upper control lever (74) to "lift", the above-mentioned operations ensue and, in addition, the horizontal switch (153), for suppressing the horizontal tonearm movement, is moved to its respective operating position, while a gap is produced in the tooth rim by the withdrawal of the tooth segment (152). The movement of the control cam (150) is interrupted and the tonearm (42) remains in its lifted position in frictional engagement above the tonearm rest (72). From this position, the tonearm (42) can, manually, be moved to any position to be lowered on the record.

Stop

If the upper control lever (74) is moved to "stop", the actuator (134) brings the dropping mechanism out of engagement so that no additional records are dropped. The shut-off lever (102) is not allowed to move to operating position; the stop switch (151) is maintained in its position and frees the cam track for the automatic final shut-off.

Short-circuiter

During the changing cycle, the two channels are shorted against the chassis to avoid disturbing extraneous noise in the loudspeaker. The short-circuiter (165) is operated by the shorting cam (154) provided at the outside edge of the control cam (150).

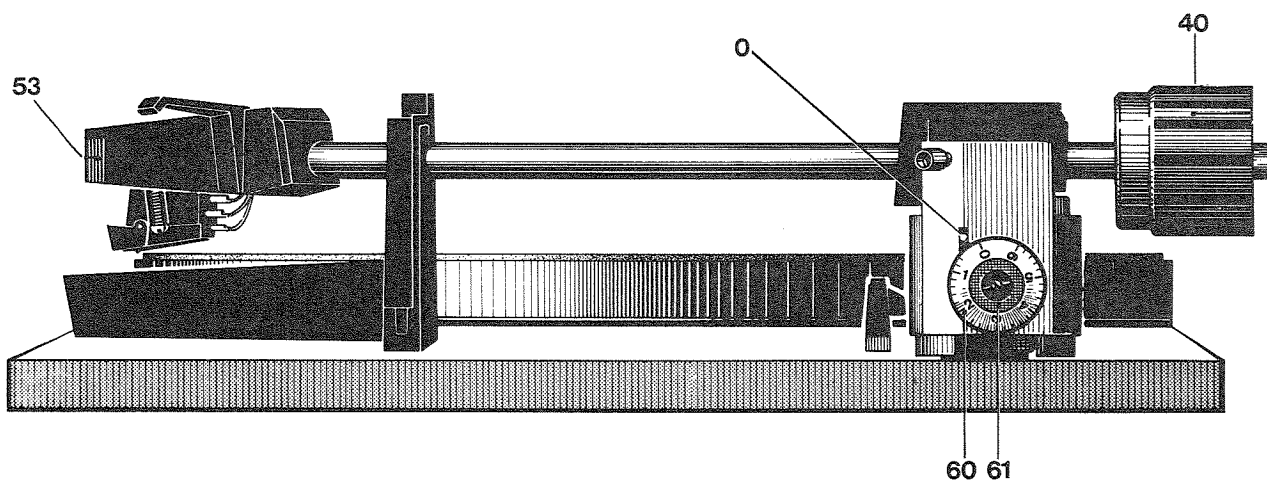

Item No.	Description
40	Tonearm counterweight
53	Slide carrier assembly
60	Graduated dial
61	Setting disk

Tonearm

The tonearm is balanced by means of the counterweight by axial movement of the latter on the tail end of the tonearm. The pickup with the slide carrier must be incorporated for this adjustment.

For protecting the tonearm bearing against shocks and for absorbing vibrations, the counterweight is elastically mounted to the tonearm tube. The tracking behaviour of the tonearm and thus the most important quality characteristic of the tonearm is determined by its bearings. To assure the minimum possible friction for the horizontal movement of the tonearm, we have, therefore, used a superfine twin ball-bearing, the brasses of which have an extra-fine finish. The bearing permitting the vertical movement of the tonearm also consists of two superfine ball-bearings with a specially treated surface. The very small frictional forces of the tonearm are of extreme importance for the antiskating device.

Dependability features

If the horizontal movement of the tonearm (42) is interfered with or if the unit is started while the tonearm (42) is still locked, this cannot affect the operation of the record player because the tonearm (42) is connected to the operating mechanism for the horizontal movement by means of a slipping clutch (114). The tonearm lifting elements are resilient to permit the lifted tonearm (42) to be pressed down without allowing any permanent deformation to interfere with the proper operation of the record player. When the unit is started without a record on the turntable platter, the tonearm (42) remains on its rest. The feeler pin (6) and the sensing lever (183) remain unaffected by a record during the sensing operation. Since the feeler pin maintains its position, the lower locating lever (170) is not repelled so that the tonearm is prevented from moving in on the record.

Chassis plate

The chassis plate is a laminated board. A .032" (0.8 mm) thick aluminum sheet is laminated upon the .06" (1.5 mm) steel plate, using a heat-sensitive adhesive at a high temperature and pressure. This ensures a high degree of rigidity and minimizes resonance.

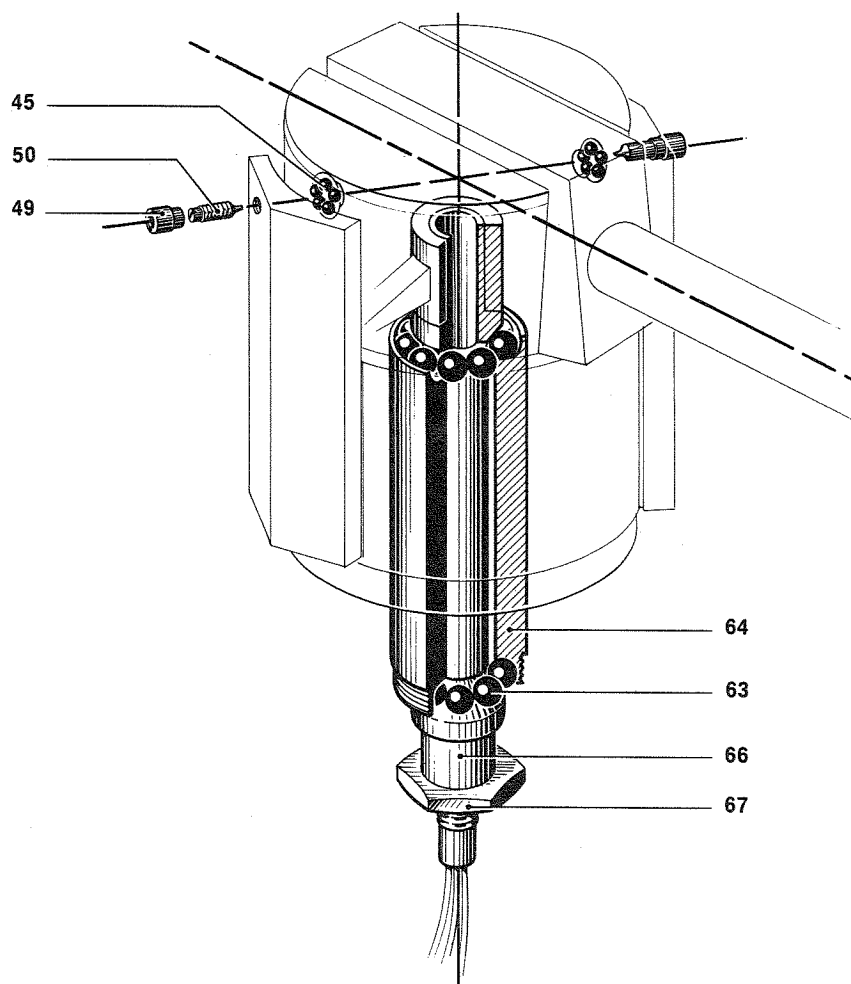

Item No.	Description
45	Steel ball .04"
49	Cap for pivot screw
50	Pivot screw
63	Ball race for tonearm bearing
64	Bearing bushing for tonearm
66	Lower tapered bushing
67	Hexagon nut M 5.8 x 0.35

alignment with the tonearm. The antiskating device is controlled by means of a control knob. Corrections are needed where different stylus tip radii, elliptical needles or wet playback are used.

Repeat

After unlocking the changer spindle, the record changer will play a record and then repeat it over and over again. The next record will only be dropped after the changer spindle has been locked.

Antiskating device

Since the tonearm is not infinitely long and since the pickup head is arranged to form a certain angle with the tonearm tube, a small force results at the tonearm that tries to impell the tonearm towards the center of the record. This skating force, as it is called, has the effect that the stylus exerts more pressure on the inside edge than on the outside edge of the record groove.

The skating force is a function of the stylus pressure, the stylus tip radius and the frictional conditions existing between the stylus and the record. The antiskating adjustment is made by adjusting the stylus force. This is done by a spring arranged in axial

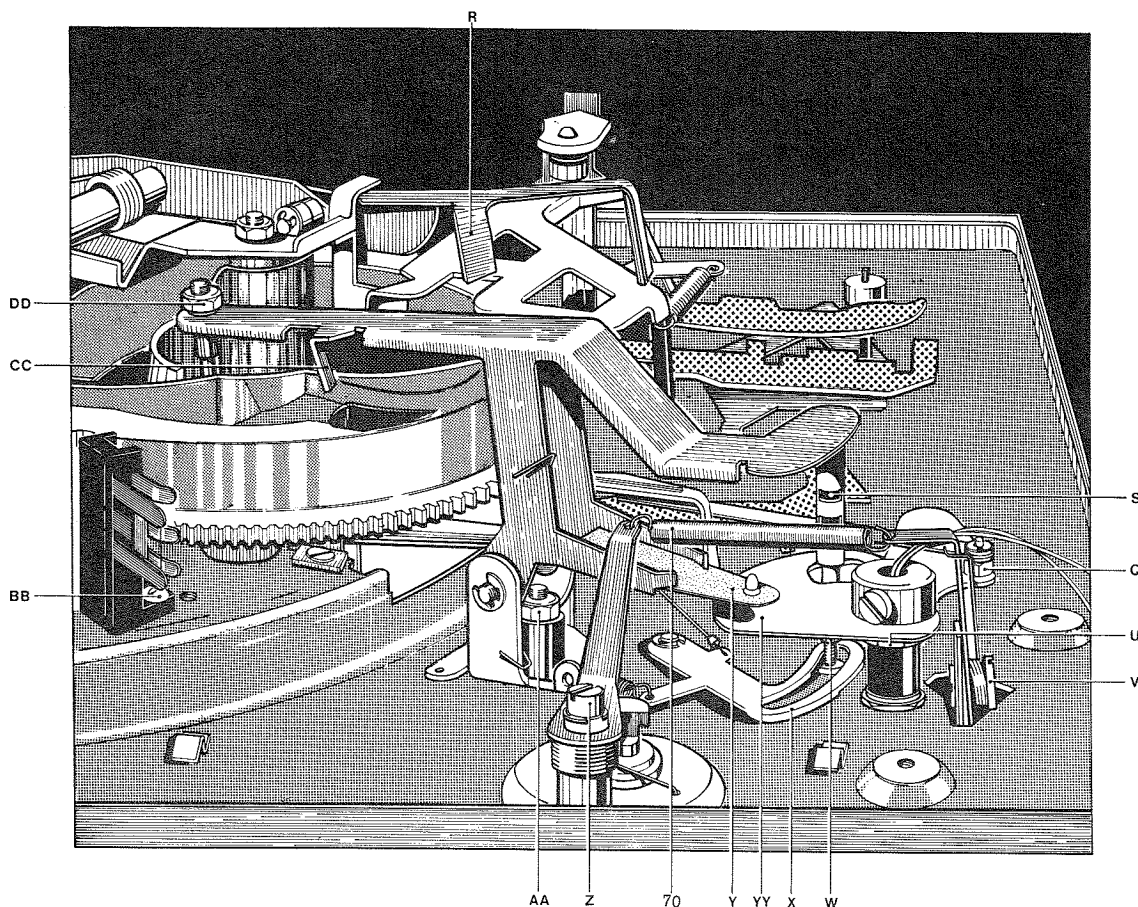

Item No.	Description
AA	Feed lever friction
BB	Short-circuiter retaining screw
CC	Feed lever lug
DD	Feed lever guide post
Q	Locator segment eccentric pin
R	Shut-off lever lug
S	Lift rod
U	Tonearm bearing nut
V	Antiskating device
W	Lift rod hexagon nut
Y	Friction spring
70	Antiskating spring
YY	Tonearm locator segment

Adjusting instructions

Needle lands irregularly on record

Cause: Feed lever (180) is out of adjustment.

Remedy: Adjust the guide post (DD) at the feed lever.

Overstroke

Adjust the overstroke by means of the guide post (DD) of the feed lever (180) to about .04" (1 mm) in the upper position of the feed lever and with a record spindle inserted. The amount of overstroke is visible in the slot (S) of the guide bushing (187). With the automatic changer spindle inserted, the edge of the pin is in about the middle of the lower slot (S). After the adjustment, the guide post (DD) must be locked by means of the locknut. Adjust the overstroke with the tonearm unlocked. When checking the parts,

make sure to see that the feed lever has a little play in its bearing. The friction covering of the friction spring (Y) of the friction bearing must be seated on the tonearm locator segment (YY) in the middle of its cusp.

Adjusting tools: Screwdriver, 5.5 mm hexagon wrench, pliers

Changing cycle occurs too early

Cause: Trip link is adjusted too close to reject lever.

Remedy: Adjust trip link as required by means of the eccentric on the tonearm locator segment.

Begin of tripping cycle

The eccentric pin (Q) on the tonearm locator segment makes it possible to change the position of the trip link and thus to advance and retard the beginning of the tripping cycle. The tripping cycle, i. e. the rejection of the trip link should occur at a diameter of $4 \frac{23}{32}$ " (120 mm) \pm $\frac{13}{64}$ " (5 mm). The position of the trip link (117) relative to the reject stud can be adjusted by moving the trip link guide (P) as required. Loosen the fastening screw in the first place. The trip link guide (P) can be moved in the longitudinal slot until the trip link does no longer change its position when the control cam continues to advance.

Adjusting tools: 5.5 mm hexagon wrench, screwdriver

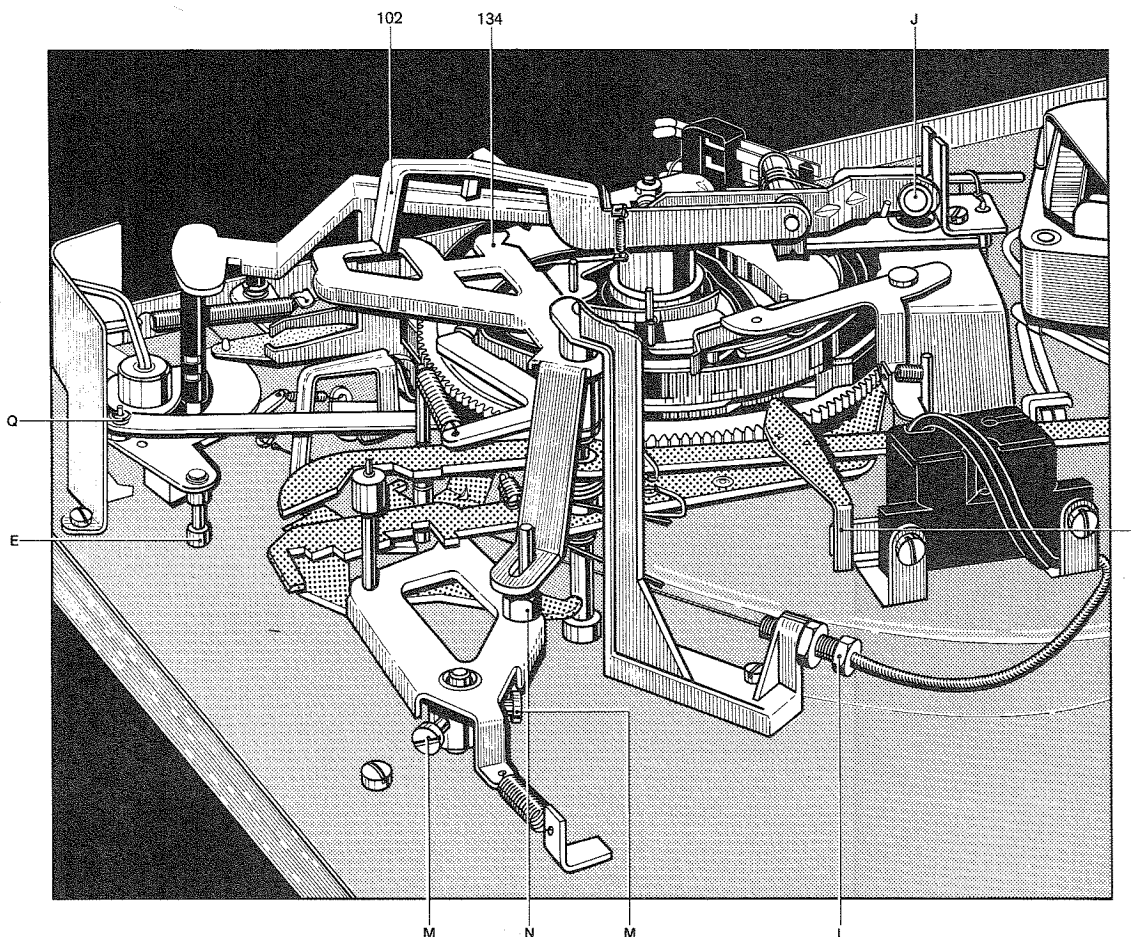

Item No.	Description
102	Shut-off lever
134	Actuator
E	Landing point
J	Dropping assembly eccentric
K	Switch operating lever lug
M	Control lever bottom assembly screw
N	Control lever bottom assembly eccentric
Q	Trip link adjusting pin (eccentric)

Needle fails to land at proper point

Cause: Tonearm locator segment (YY) is out of adjustment with the adjusting eccentric (E)

Remedy: Turn the eccentric (E) clockwise to move the needle landing point to the right, turn it counterclockwise to shift the landing point to the left.

Landing point

A hole (E) in the chassis plate permits adjustment of the needle landing point by turning the eccentric (E). Turn the eccentric clockwise to move the landing point towards the outside, turn it counterclockwise to move the landing point towards the inside.

Adjusting tool: Screwdriver

Records fail to drop from the spindle

Cause: Eccentric (J) at drop lever (97) out of adjustment.

Remedy: Adjust eccentric (J) in such manner that the record shelves are flush with the outside diameter of the automatic record spindle.

Dropping assembly

Adjust the push-rod extension for the record spindle below the turntable bearing by means of the eccentric (J) so that the record shelves are even with or slightly withdrawn behind the outside diameter of the automatic record spindle.

Adjusting tool: 7 mm hexagon wrench

Control lever

After loosening the retaining screws (M) in the control lever bottom assembly, the control lever (108) can be shifted to agree with the operating symbols on the chassis plate.

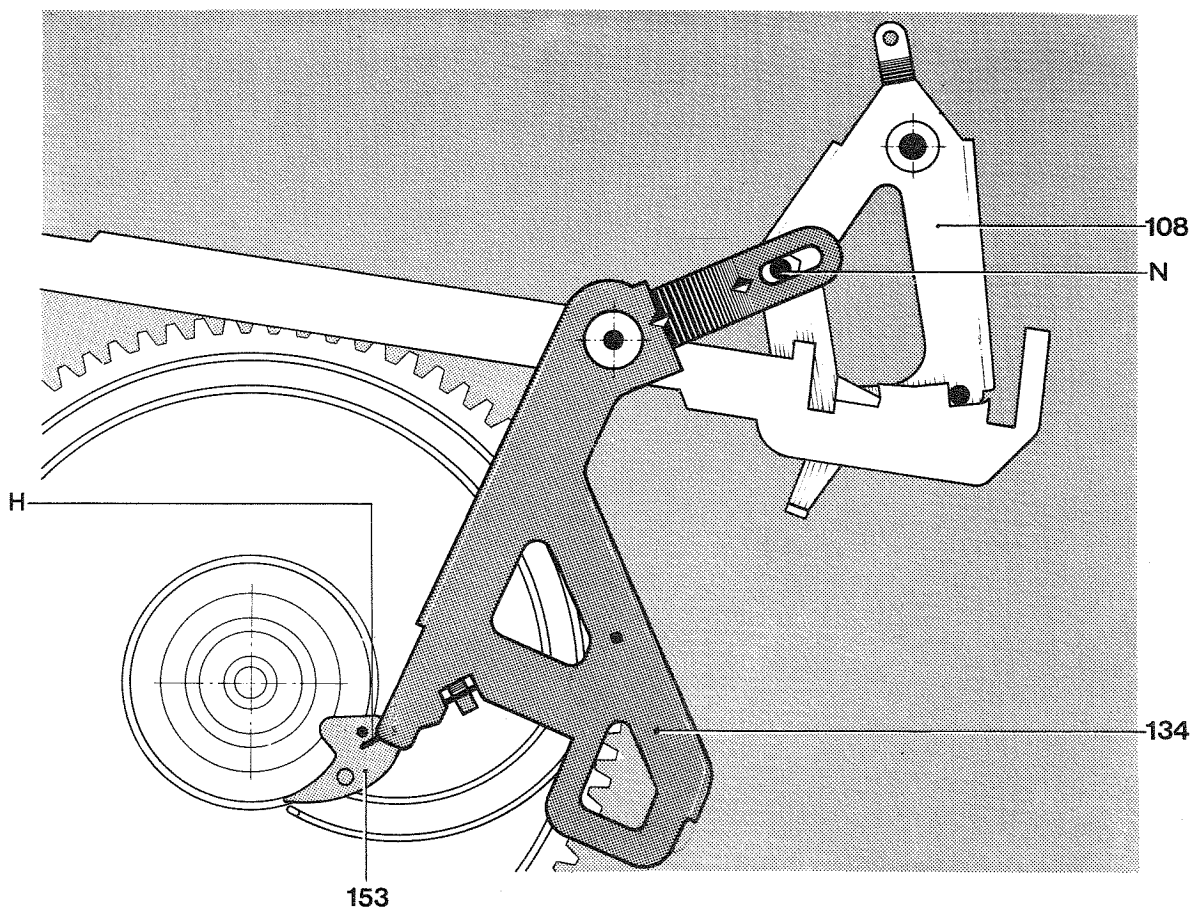

Item No.	Description
153	Horizontal switch
108	Control lever bottom assembly
134	Actuator
N	Control lever bottom assembly eccentric
H	Actuator spring

Tonearm fails to swing in after record has been dropped

Cause: The lug (R) at the shut-off lever is bent out of adjustment, stop switch (151) is not reversed.

Remedy: Bend lug (R) of shut-off lever as required.

Actuator position

Following the lifting operation, the control lever is deflected. When the control cam is turned, the horizontal switch must be reversed by the spring (H) of the actuator (134). As the cam turns, the angle piece at the turntable bearing bracket must force the tooth segment to its outer position. To adjust, bend the angle piece as required. As the cycle continues, the tooth segment is moved to its inside position by the spring (H) of the actuator (134). Adjust the position of the actuator by means of the eccentric (N) of the control lever bottom assembly.

Adjusting tools: 7 mm hexagon wrench, pliers

Tonearm too high or too low

Cause: Lift rod out of adjustment.

Remedy: Adjust tonearm lift rod by turning the adjusting nut (W).

Adjusting the height of the tonearm

The height of the tonearm is adjusted by means of the tonearm lift rod. The adjusting nut can be turned up or down. Measure the height of the tonearm above the chassis plate by means of a tonearm height gauge.

Adjusting tools: 5.5 mm hexagon wrench, tonearm height gauge

Feed lever

As the control cam (150) moves to "LIFT" position, the lug (CC) of the feed lever (180) must operate the stop switch (151). If not, correct by bending the lug (CC) of the feed lever as required. Make this adjustment with a record spindle in place.

Adjusting tool: Pliers

Final shut-off

In the "STOP" and "LIFT 1" positions, the shut-off lever (102) must be blocked by the actuator (134). In the normal position and in "START" position, the shut-off lever (102) must not be allowed to rub on the actuator (134). Without a record spindle in place, the oblique lug of the shut-off lever must operate the stop switch. Correct by bending at the shut-off lever as required.

Adjusting tool: Pliers

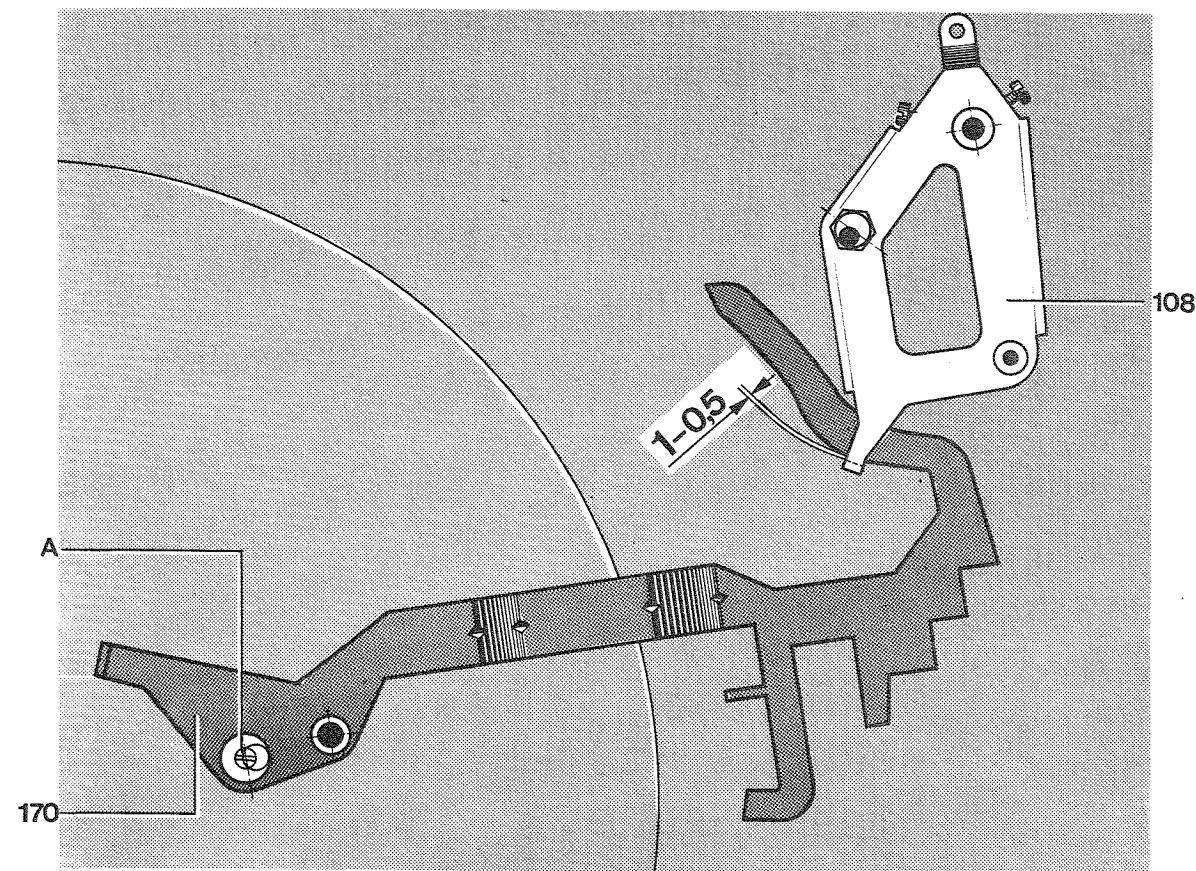

Item No.	Description
170	Lower locating lever
108	Control lever bottom assembly
A	Locating lever eccentric

Turntable bearing bracket

Loosen the retaining screws (28) and move the bearing bracket as required to ensure easy engagement of the turntable pinion.

Control lever cannot be moved to LIFT

Cause: Clearance between the lower locating lever (170) and the bent portion of the control lever bottom assembly (108) too small.

Remedy: Adjust the eccentric (A) at the lower locating lever.

Position of lower locating lever

The clearance between the curved extension of the lower locating lever (170) and the control lever bottom assembly can be adjusted by means of the eccentric (A) at the left of the pivot. For this purpose, the control lever must be in the 1st lift position. The clearance should be between 20 and 40 mils (0.5 to 1 mm).

Adjusting tool: Screwdriver

Switch operating lever

In the normal position of the control cam, the lever (K) must clear the ON/OFF switch about 20 mils (0.5 mm). When the control lever is moved to "START" or "LIFT", the red lever of the ON/OFF switch must be supported on the backstop. If the

starting lever (128) is engaged with the stop pawl, the switching roller (109) must clear the starting lever (128) 8 mils (0.2 mm) in any position of the control lever.

Adjusting tool: Pliers

Tonearm has no friction

Cause: Insufficient spring contact (Y) on tonearm locator segment (YY).

Remedy: Adjust the friction spring (Y) as required.

Tonearm friction

The tonearm friction is of the order of 20 to 40 g. Bending the spring supports (Y) permits changing the position of the spring with respect to the tonearm locator segment (YY). Care should be taken to see that a clearance of .571" (14.5 mm) exists between the lower edge of the tonearm locator segment (YY) and the chassis board.

Adjusting tools: Pliers, contactor

Operating noise heard during change cycle

Cause: Short-circuiter fails to make contact properly.

Remedy: Adjust short-circuiter.

Short-circuiter

In playback position of the record player, the two shorting springs should clear the contact bars .020" (0.5 mm). Loosen the retaining screws of the short-circuiter and turn the short-circuiter until this clearance is obtained.

Adjusting tool: Screwdriver

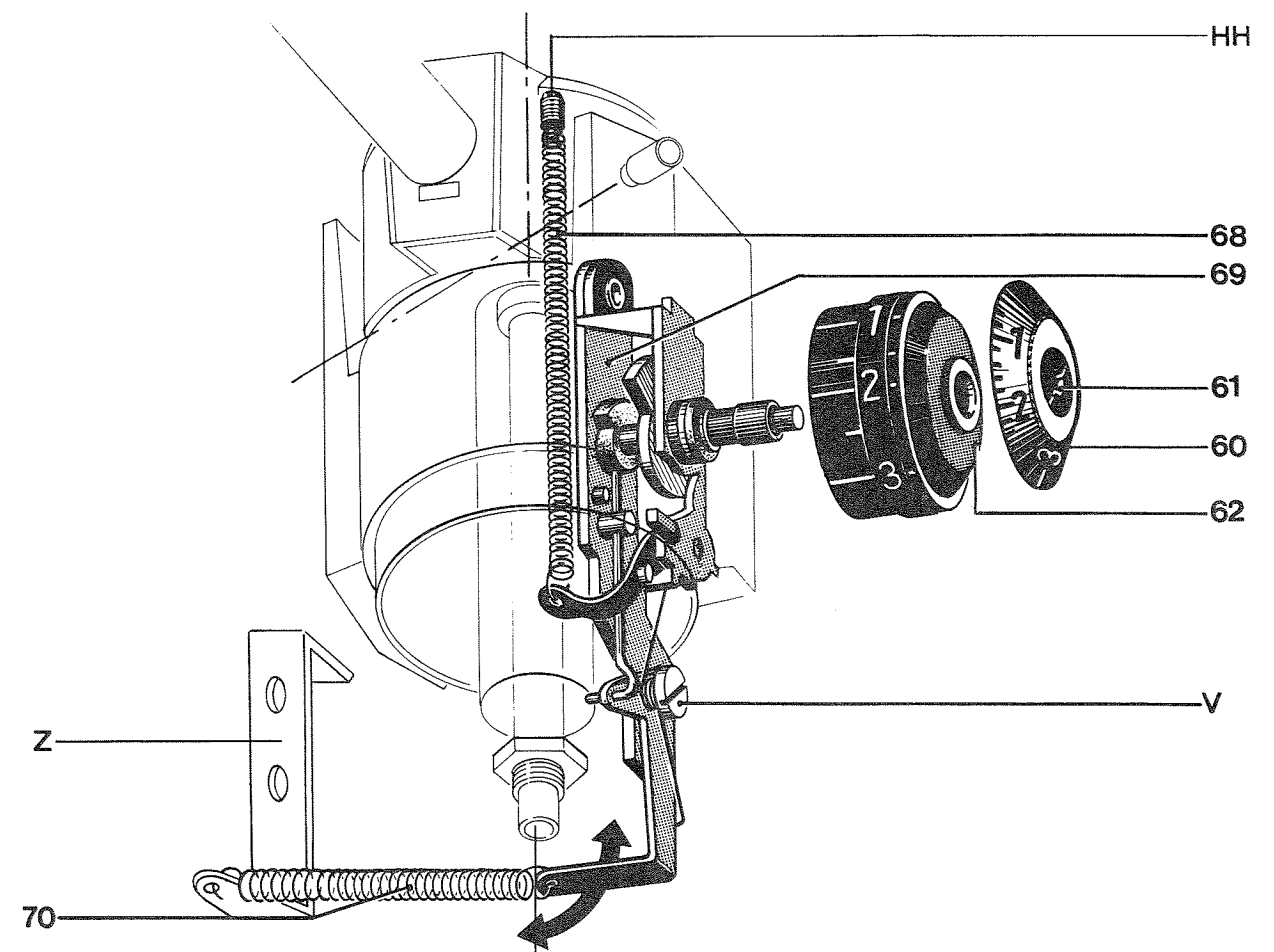

Item No.	Description
60	Graduated dial
61	Setting disk
62	Tonearm tracking weight adjusting knob
68	Drawspring of tonearm tracking weight
69	Antiskating subassembly
70	Antiskating spring
V	Setting arm eccentric
HH	Stylus pressure adjustment screw
Z	Angle plate for antiskating precision adjustment

Stylus force too high or too low

Cause: Tonearm is not properly balanced. Adjusting knob fails to agree with the red mark.

Remedy: Balance the tonearm properly. Place the adjusting knob to the proper position.

Stylus force

Remove the retainer and pull off the graduated dial and the tonearm tracking weight adjusting knob. Turn the bearing sleeve counterclockwise as far as it will go. Replace the adjusting knob with the red line to agree with the zero mark. Replace the graduated dial and secure by means of the retainer. Set the stylus pressure at 1 g by means of a spring balance. A screw (HH) in the crossbar permits compensating a possible discrepancy.

Adjusting tools: Screwdriver, spring balance

Antiskating device

Move the adjusting knob for the stylus force to zero position. Then, adjust the setting arm by means of the eccentric (V) below the chassis plate in such manner that the receiving point of the spring agrees with the turning point of the tonearm. If, when adjusting the stylus pressure, an overcompensation of the skating force is found to exist, the spring length tolerance can be corrected by bending the angle plate (Z).

Sensing lever

In the normal position of the record player, the sensing pin (182) must be in the center of the hole. If necessary, adjust in the middle of the sensing lever. Without a record on the turntable platter, the sensing pin must not be allowed to rub on the outside edge of the turntable.

Vertical tracking angle adjustment

Only applicable to record players equipped with slide carrier permitting vertical tracking angle adjustment.

Since the master recordings are cut at an angle of 15°, the inherent distortions of the pickup when reproducing a recording are at their lowest when the needle moves in the sound grooves at the same angle of 15°. The adjustment of the vertical tracking angle is possible in the pickup head.

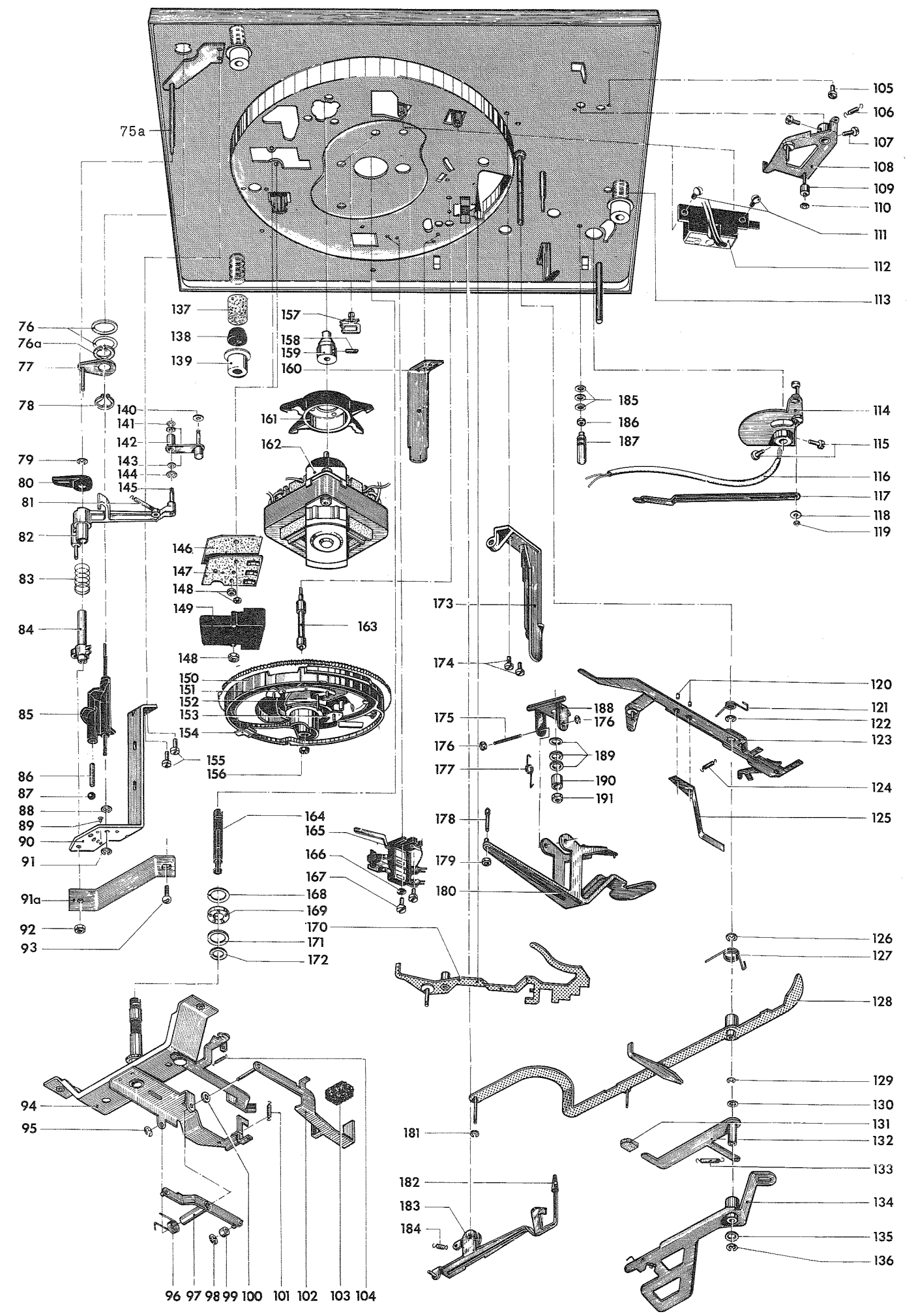
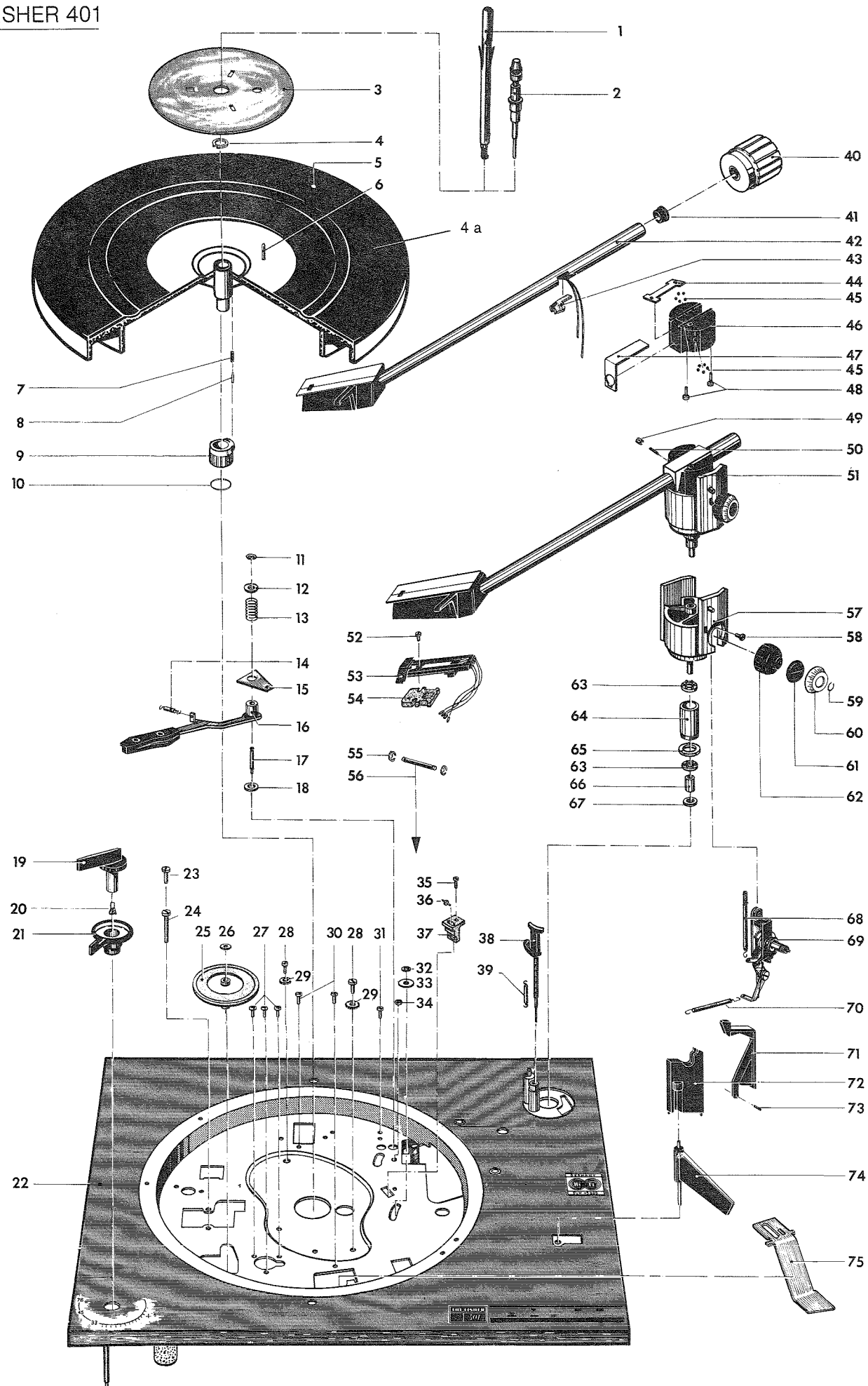

Item	Part No.	Description	Item	Part No.	Description	Item	Part No.	Description
1	TT4012-004	Automatic record spindle 7mm	67	TT4012-026-1	Hexagon nut	133	TT4012-202	Draw spring for lock pawl
1a	TT21314	Automatic record spindle 38mm	68	TT4021-068	Spring for tonearm tracking weight	134	TT4012-203	Actuator subassembly
2	TT4021-002	Single play spindle	69	TT4012-027	Antiskating assembly	135	TT4012-199	Washer 9x4.2x1
3	TT4021-003	Ornamental ring	70	TT4012-028	Antiskating spring	136	TT4012-089	"C" Clip 3.2
4	TT4021-004	Turntable retainer	71	TT4012-029	Tonearm lock	137	TT4012-115	Chassis suspension cushion
4a	TT4021-198	Turntable matting	72	TT4012-030	Tonearm rest subassembly	138	TT4021-138	Rubber damper
5	TT4021-005	Turntable platter	73	TT4021-013	Holding sleeve	139	TT4021-139	Spring cup
6	TT4021-006	Feeler pin (not available separately)	74	TT4012-032	Upper control lever assembly	140	TT4012-074	Washer
7	TT4021-007	Compression spring	75	TT4012-033	Latch (chassis securing)	141	TT4012-037	"C" Clip 2.3
8	TT4021-008	Locator bolt	75a	TT4012-069	Guide pin	142	TT4012-076	Idler wheel arm subassembly
9	TT4021-009	Pinion	76	TT4021-076	Spacing washer	143	TT4012-077	Washer
10	TT4021-010	Securing ring	76a	TT4012-070	Spring cup	144	TT4012-037	"C" Clip 2.3
11	TT4012-037	"C" Clip 2.3	77	TT4021-077	Lower locating lever	145	TT4012-079	Pivot pin for idler wheel support
12	TT4012-038	Washer 12x4x1.2	78	TT4012-073	"C" Clip 9	146	TT4012-121	Insulating clamp
13	TT4012-039	Compression spring for upper and lower locating lever	79	TT4012-080	"C" Clip 6	147	TT4012-122	Terminal plate
14	TT4012-040	Draw spring for upper locating lever	80	TT4012-081	Adjusting arm	148	TT4012-094	Hexagon nut M3
15	TT4012-041	Securing clip	81	TT4021-081	Draw spring	149	TT4021-149	Covering plate
16	TT4012-042	Upper locating lever	82	TT4021-082	Idler wheel support assembly	150	TT4012-128	Control cam assembly
17	TT4012-043	Pivot pin	83	TT4012-084	Compression spring	151	TT4012-129	Stop switch
18	TT4012-044	Washer 8x3.2x1.5	84	TT4012-085	Shift fork subassembly	152	TT4012-130	Tooth segment
19	TT4012-006	Speed selector knob	85	TT4021-085	Speed selector cam assembly	153	TT4012-131	Horizontal switch
20	TT4021-020	Plate spring for speed setting knob	86	TT4012-087	Compression spring	154	TT4012-132	Shorting cam (not available separately)
21	TT4021-021	Locating lever	87	TT4012-088	Steel ball	155	TT4012-067	Fillister head screw AM 3x4
22	TT4021-022	Chassis board assembly	88	TT4012-089	"C" Clip 3.2	156	TT4012-055	Hexagon nut M3.5
23	TT4012-137	Fillister head screw M 3x8	89	TT4021-089	Stop bolt	157	TT4012-117	Cable holder
24	TT4012-060	Fillister head screw M 3x20	90	TT4012-090	Holding bracket	158	TT4012-124	Grub screw 3.5x5
25	TT4012-061	Idler wheel assembly	91	TT4012-089	"C" Clip 3.2	159	TT4021-159-1	Motor pulley 50 Hz
26	TT4012-062	Washer for idler wheel	91a	TT4021-091-1	Angle bracket	159	TT4021-159-2	Motor pulley 60 Hz
27	TT4012-063	Fillister head motor suspension screw AM 3x15	92	TT4012-094	Hexagon Nut M3	160	TT4012-134	Seating bracket
28	TT4012-066	Fillister head screw AM 4x8	93	TT4012-067	Fillister head screw AM 3x4	161	TT4021-161	Motor fixing latch
29	TT4012-064-2	Washer	94	TT4021-094	Turntable bearing bracket assembly	162	TT4021-162	Shaded pole motor SPM 4/15
30	TT4012-050	Fillister head lever securing screw AM 3x5	95	TT4012-037	"C" Clip 2.3	163	TT4012-127	Bearing pin for control cam
31	TT4012-067	Fillister head seating bracket screw AM 3x4	96	TT4012-107	Torsion spring	164	TT4021-164	Push rod extension
32	TT4012-053	"C" Clip 1.9	97	TT4012-108	Drop lever subassembly	165	TT4012-135	Muting switch
33	TT4021-033	Washer for ratchet lever	98	TT4012-037	"C" Clip 2.3	166	TT4012-111	Washer
34	TT4012-055	Hexagon nut M 3.5	99	TT4012-110	Roller for drop lever	167	TT4012-137	Fillister head screw M3x8
35	TT4012-050	Fillister head trip link guide screw AM 3x5	100	TT4012-111	Washer 3.2	168	TT4012-097	Upper washer
36	TT4012-051	Guide roller (friction roll)	101	TT4012-040	Draw spring for shut-off lever	169	TT4012-022	Ball race
37	TT4012-052	Trip link guide	102	TT4012-113	Shut-off lever subassembly	170	TT4012-197	Starting lever subassembly
38	TT4012-057	Lift rod assembly	103	TT4021-103	Foam rubber	171	TT4012-099	Lower washer
39	TT4012-058	Draw spring for lift rod	104	TT4012-114	Draw spring for stop pawl	172	TT4012-100	Cushioning washer
40	TT4021-040	Tonearm counterweight	105	TT4012-050	Fillister head screw AM 3x5	173	TT4021-173	Support bracket
41	TT4021-041	Cap	106	TT4012-173	Draw spring	174	TT4012-142	Cylindrical screw AM 3x6
42	TT4021-042	Tonearm assembly	107	TT4012-142	Cylindrical screw 3x6	175	TT4012-049	Pivot pin for feed lever
43	TT4021-043	Fixing clamp	108	TT4012-175	Control lever bottom assembly	176	TT4012-037	"C" Clip 2.3
44	TT4021-044	Fixing plate	109	TT4012-176	Switching roller	177	TT4012-145	Torsion spring for feed lever
45	TT4012-013	Steel ball 1mm	110	TT4012-177	"C" Clip 1.2	178	TT4012-146	Guide screw for feed lever
46	TT4021-046	Tonearm bearing frame assembly	111	TT4012-050	Fillister head screw AM 3x5	179	TT4012-094	Hexagon nut M3
47	TT4012-015	Shield for bearing frame	112	TT4012-179	ON/OFF switch	180	TT4012-150	Feed lever
48	TT4012-016	Fillister head screw 2.9x16	113	TT4021-113	Suspension spring	181	TT4012-037	"C" Clip 2.3
49	TT4012-018	Cap for bearing screw	114	TT4012-184	Tonearm locator segment	182	TT4021-182	Sensing pin
50	TT4012-017	Bearing screw	115	TT4012-185	Cylindrical screw AM 3x5	183	TT4021-183	Sensing lever
51	TT4021-051	Tonearm and base assembly, without slide carrier	116	TT4021-116	Rubber tube	184	TT4012-155	Draw spring for sensing lever
52	TT4021-052	Countersunk screw AM 3x5	117	TT4012-186	Trip Link	185	TT4012-111	Washer for lift rod
53	TT4021-053	Slide carrier subassembly, black	118	TT4012-187	Paper washer	186	TT4012-162	Lock nut
54	TT4021-054	Intermediate plate	119	TT4012-188	"C" Clip 1.5	187	TT4012-163	Guide sleeve subassembly
55	TT4012-037	"C" Clip 2.3	120	TT4012-189	Tube rivet	188	TT4012-167	Bearing plate for feed lever
56	TT4012-049	Pivot pin for sensing lever	121	TT4012-190	Torsion spring for ratchet lever	189	TT4012-169	Spring washer A5
57	TT4012-019	Tonearm base assembly	122	TT4012-089	"C" Clip 3.2	190	TT4012-170	Compression sleeve for feed lever
58	TT4012-020	Countersunk screw	123	TT4012-192	Ratchet lever	191	TT4021-191	Securing nut M4
59	TT4021-059	Securing ring	124	TT4012-193	Draw spring for ratchet lever	192	TT4021-192	Tonearm lead for right channel
60	TT4021-060	Graduated dial	125	TT4012-194	Flat switch spring		TT4021-193	Tonearm lead for left channel
61	TT4021-061	Setting disk	126	TT4012-089	"C" Clip 3.2		TT4021-194	Tonearm lead for ground
62	TT4021-062	Setting knob subassembly	127	TT4012-196	Torsion spring for starting lever		TT4012-011	Fixing tube
63	TT4012-022	Ball race	128	TT4012-197	Starting lever subassembly		TT4021-195	Twin pick-up cable
64	TT4012-023	Bearing bushing for tonearm	129	TT4012-089	"C" Clip 3.2		TT4021-196	Mains connecting cord 1.5m
65	TT4012-024	Hexagon nut	130	TT4021-130	Washer 9x4.3x1		TT4012-118	Fixing clamp
66	TT4012-025	Tapered bushing	131	TT4012-200	Lock segment		TT4012-111	Washer 3.2
			132	TT4021-132	Lock pawl subassembly		TT4021-197	Spring for stop switch

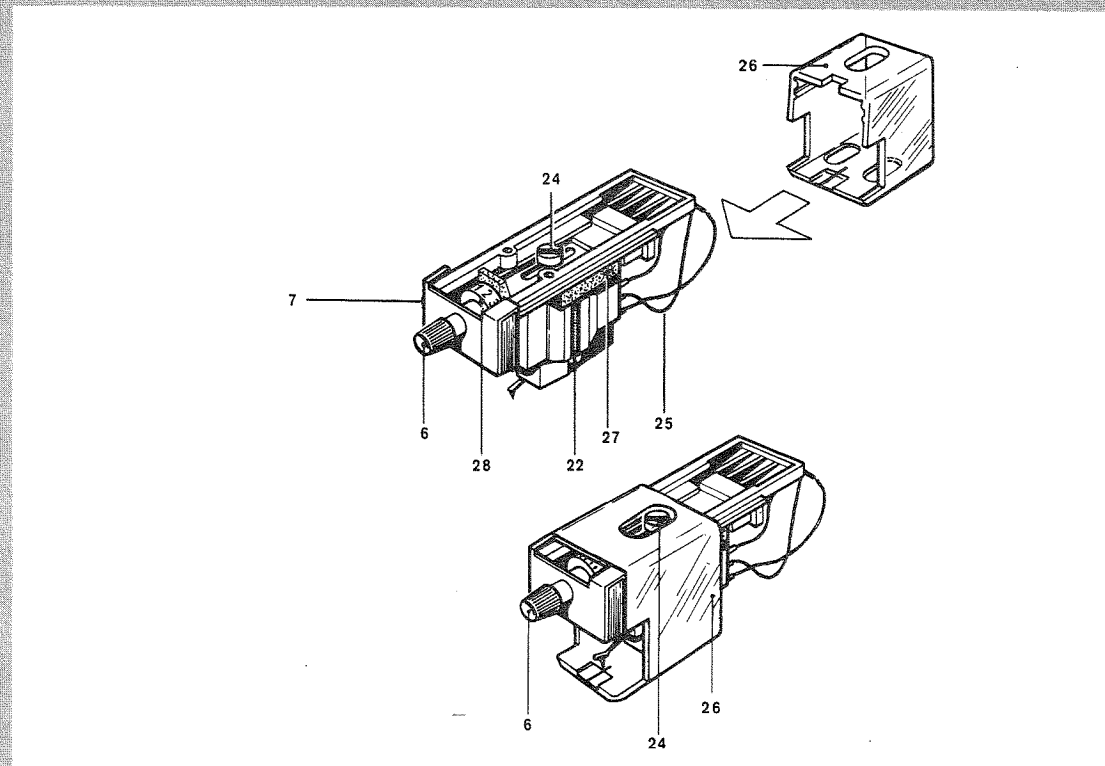

NOTE: The numbers indicated refer to the operating instructions. All pickups with 1/2" international standard mounting facilities can be mounted.

Pick-up head

When mounting pick-ups on the pick-up head (7) it must be kept in mind that the playback needle must be in an accurately defined geometric position. The mounting gauge (26) supplied with turntables without pick-up makes it possible to check the pick-up for correct position.

Mounting pick-ups on the pick-up head
(only applicable to units without pick-up)

To mount a pick-up, please proceed as follows:

- 1) Turn the rotary knob for the tracking angle adjustment (6) to position 1. Then, mount the pick-up by means of the screws (22) and spacer rollers included in the accessories so on the pick-up retaining plate (27) that the needle of the pick-up is exactly in the center of the two intersecting lines of the mounting gauge (26) that has been slipped over the guide grooves of the pick-up head. In this position, the needle should just touch the inside surface of the mounting gauge. Choose the size of the screws and of the spacer rollers as required for the pick-up.
- 2) Loosen the retaining screws (22) of the pick-up up once more a little and move the pick-up side-wards until the needle agrees with the longitudinal line. Tighten the retaining screws again.

- 3) For the longitudinal movement of the pick-up, loosen the screw (24) and shift the pick-up until the needle coincides exactly with the cross-line of the two intersecting lines on the mounting gauge (26). Tighten the screw again.

The pick-up is now accurately adjusted and you have the guarantee that the needle will always land in the starting groove of the record in automatic operation.

The slide-in pick-up head is equipped with a 5-pole connector. Both the two chassis connections of the channels and also the grounds of the pick-up can be separately connected. In the case of a regular model, i. e. when the grounds in the pick-up head is connected to a chassis pin, the leads (25) should be connected as follows:

- red = right-hand channel
- white = left-hand channel
- green = right-hand ground
- blue = left-hand ground

Tracking check

To prevent geometric playback errors, the horizontal distance of the needle tip must also be correctly adjusted. In the FISHER pick-up arm this is the case when the pick-up needle coincides with the intersecting lines of the mounting gauge. If the pick-up is installed by the customer, adjustment to the optimum conditions is possible.

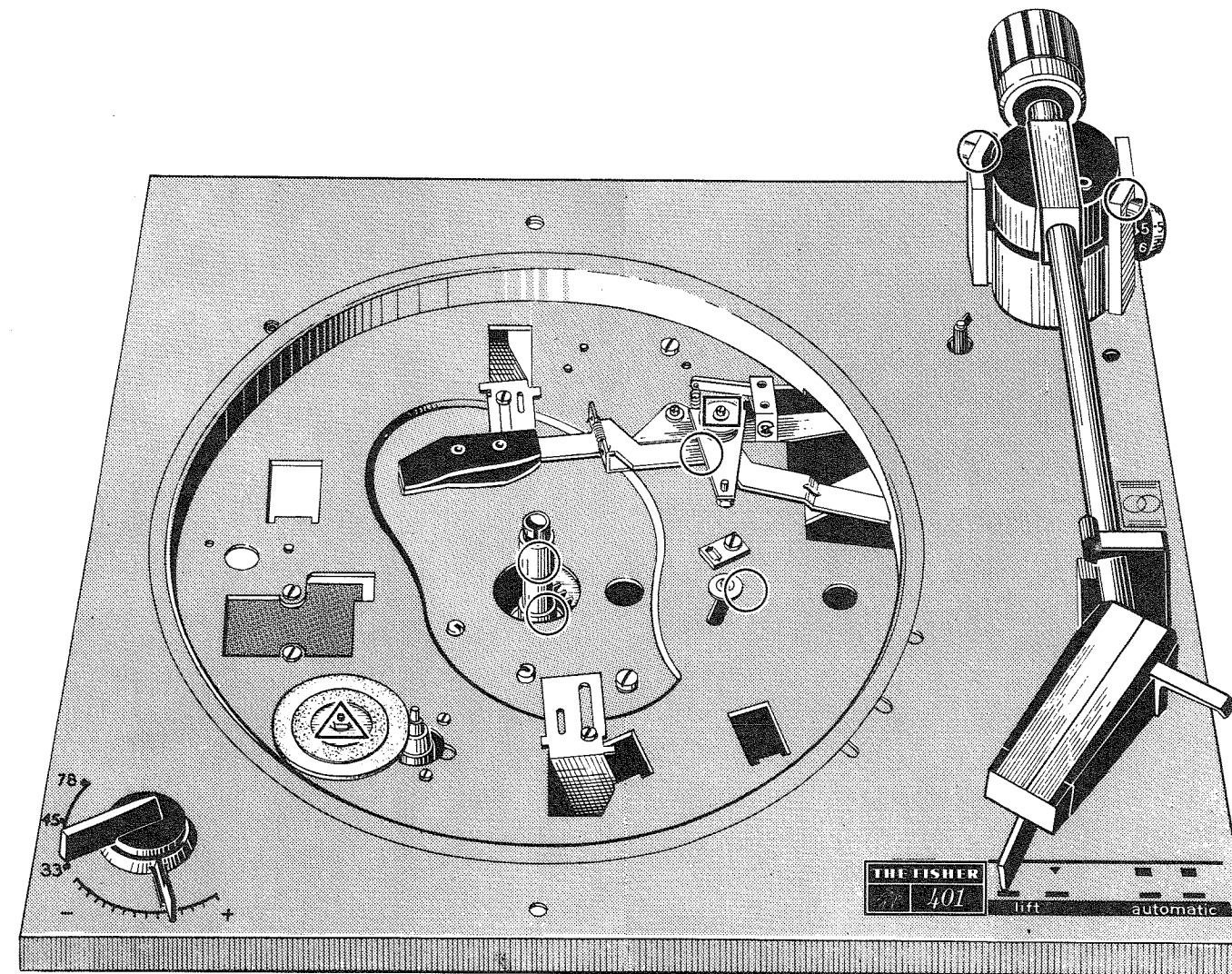

Lubricating instructions

When the record changer is assembled, all sliding and bearing points are sufficiently packed with lubricants. Relubrication of these points is required after about 1000 operating hours in normal operation. The following oils and greases should be used for this purpose:

□ = Oil ○ = Grease △ = Graphite grease

Lubricating points

	Item No.
□ Upper control lever assembly bearing	74
□ Idler wheel support pivot	
□ Idler wheel arm bearing	142
○ Speed selector cam bearing and cam track with ball ratchet arrangement	85-90
□ Vertical tonearm bearing (lubricate thriftily)	63-67
□ Ratchet lever pivot bearing	123
□ Sensing lever bearing	183
□ Lower locating lever bearing	170
□ Trip link bearing at eccentric pin	117

□ Starting lever bearing	128
□ Lock pawl bearing	132
□ Actuator bearing	134
○ Speed selector knob bearing	19
□ Lift rod — in the range of the guide sleeve	38
□ Feed lever bearing	180
○ Adjusting arm slot	80
○ Upper locating lever bearing	21
○ Silicone oil AK 300 000 for	
○ Lift rod only, ground surface	38
○ Horizontal bearing	45
△ Bearing plate for feed lever	188
○ Ratchet lever bearing in elongated hole of chassis plate	
□ Upper locating lever — bearing and friction	16
○ Control cam bearing, sliding faces and cam track, except for tooth rim	150
○ Push rod extension	164
○ Drop lever eccentric	97
○ Shut-off lever/drop lever bearing	102/97
○ Turntable bearing with ball-bearing	168/169/171
○ Sliding faces of ratchet and starting levers for starting pin	123/128
○ Actuator slot	134
○ Lift rod friction face	38
○ Idler wheel bearing	25
△ Feed lever sliding face for guide sleeve	180
○ Control lever bottom assembly, hole for drawspring	108
○ Push rod extension	164

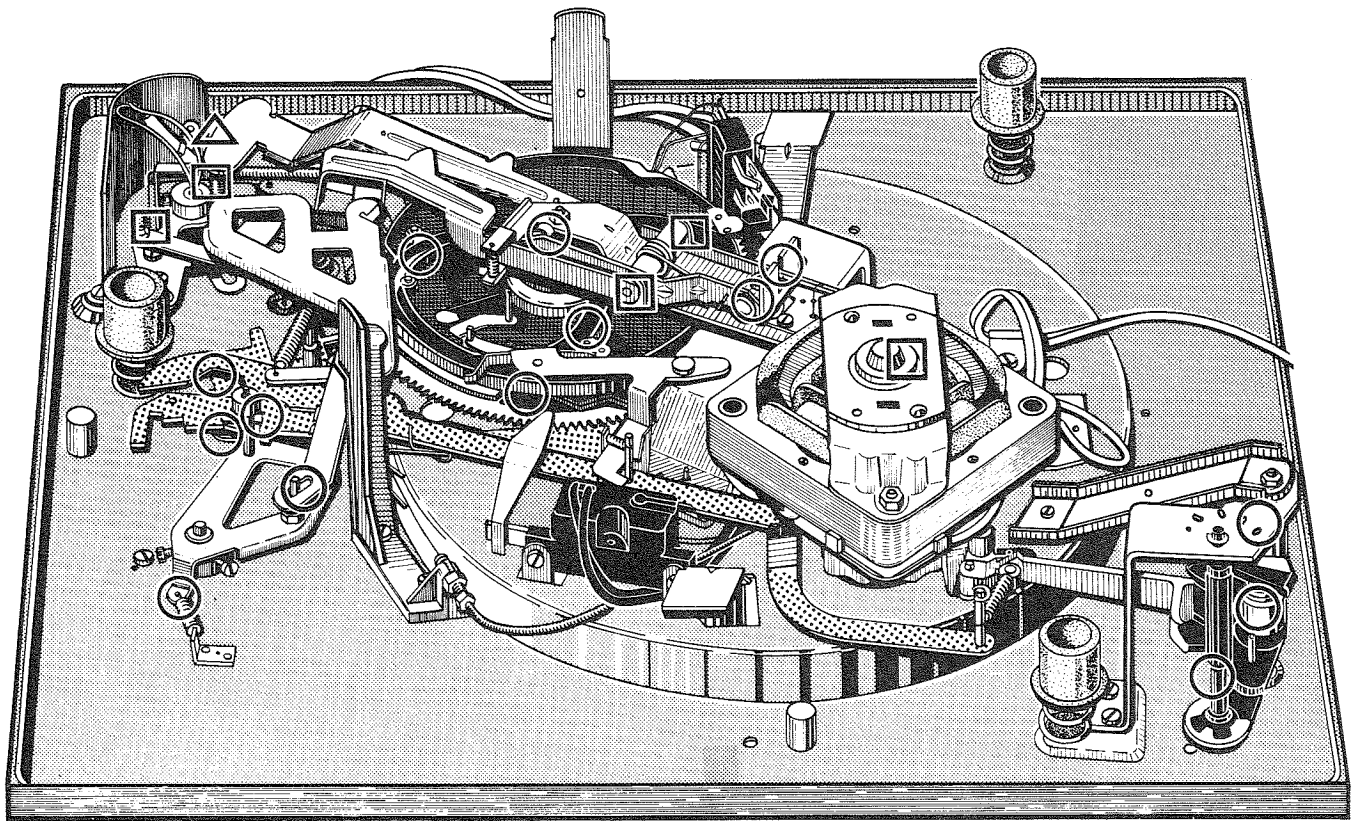

□ Oil

○ Grease

△ Graphite grease

It is important that no oil or grease be allowed to get to the friction faces of the idler wheel, of the turntable and the drive pulley.

Replacing the 60 Hz motor pulley with 50 Hz

The motor pulley (159) is held in place by a grub screw (158). The position of the motor pulley on the armature shaft can be changed. The idler wheel (25) must contact the individual steps of the motor pulley exactly in the middle. Care should be taken to see that the red mark of the precision control is exactly in the middle of the range. A change from 50 to 60 cycles per second can be effected by exchanging the motor pulley.

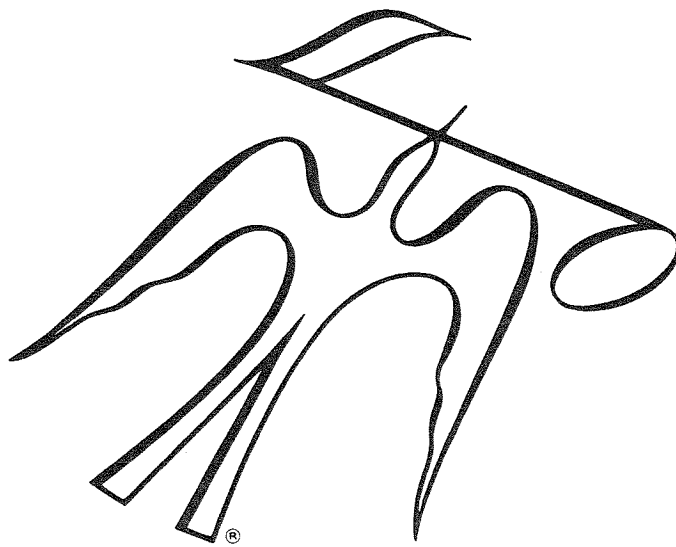

FISHER RADIO • LONG ISLAND CITY • NEW YORK 11101

NL4021-403

© COPYRIGHT 1970 FISHER RADIO ALL RIGHTS RESERVED PRINTED IN U.S.A.



2.5P40