

**SERVICE MANUAL**

# The Fisher®

# 4035

**4/2-Channel  
Stereo Receiver**



**WORLD LEADER IN HIGH QUALITY STEREO**

## TABLE OF CONTENTS

REQUIRED TEST EQUIPMENT . . . . .	2	CD-4 ALIGNMENT PROCEDURES . . . . .	8
CHASSIS PARTS LIST . . . . .	3	CD-4 DEMODULATOR PARTS LIST . . . . .	8
HARMONIC DISTORTION TEST . . . . .	3	CD-4 DEMODULATOR BOARD LAYOUT . . . . .	8
TUNER ALIGNMENT PROCEDURES . . . . .	3	SQ DECODER PARTS LIST . . . . .	8
TUNER SCHEMATIC . . . . .	4	SQ DECODER SCHEMATIC . . . . .	9
TUNER PARTS LIST . . . . .	5	AUDIO CONTROL AMPLIFIER SCHEMATIC . . . . .	10
TUNER BOARD LAYOUT . . . . .	5	AUDIO CONTROL AMPLIFIER PARTS LIST . . . . .	10
TUNER ALIGNMENT WAVEFORMS . . . . .	5	POWER AMPLIFIER SCHEMATIC . . . . .	11
TUNER IC SIGNAL FLOW . . . . .	6	POWER AMPLIFIER PARTS LIST . . . . .	11
TUNER IC CIRCUIT DESCRIPTION . . . . .	6	POWER SUPPLY/DIAL LAMP SCHEMATIC . . . . .	12
CD-4 DEMODULATOR SCHEMATIC . . . . .	7	POWER SUPPLY/DIAL LAMP PARTS LIST . . . . .	12

## REQUIRED TEST EQUIPMENT

The following test equipment is required to completely test and align the Tuner section and the CD-4 Demodulator section of the 4035 Receiver:

- Line Voltage Autotransformer or Voltage Regulator
- Frequency Indicator or Frequency Counter
- AC DC Multimeter
- Four (4) Load Resistors, 8 ohms, 50 Watts (Minimum Rated)
- Accurately Calibrated AC Voltmeter
- Low-Distortion AM-FM Signal Generator
- Oscilloscope (Flat to 100 kHz Min.)
- 10.7 MHz Sweep Generator, Fisher Model 3024 or equivalent
- Low-Distortion Audio Oscillator
- 455 kHz Sweep Generator, Fisher Model 3025 or equivalent
- Harmonic Distortion Analyzer
- Multiplex Generator, Fisher Model 1536 or equivalent
- CD-4 Generator (Fisher 3109 or equivalent)
- Two (2) RCA Shorting Plugs

**CAUTION:** This precision high-fidelity instrument should be serviced only by qualified personnel, trained in the repair of transistorized equipment and printed circuitry.

## CHASSIS PARTS LIST

Ref. Des.	Description	Part Number	Ref. Des.	Description	Part Number
	<b>FRONT PANEL</b>				
—	Jack, Earphone (4)	JK20627-5	—	Strain Relief	EM21116-8
—	Knob, TUNING	EK20056-1	—	Line Cord	W50023-1
—	Knobs (2), Control	EK20055-1	—	*Line Cord (3 Conductor)	WR20678
—	Dual Knobs (4), Top	EK20052-1	—	Circuit Breaker (85°C)	SM51455
—	Dual Knobs (4), Bottom	EK20054	—	Antenna Support Assembly	AS4130-140
—	Knobs (7), Pushbutton	EK20046-3	—	Ferrite Antenna	LA51417-2
—	Bushing, Pushbutton	EA51413	—	Antenna Support Bracket	AB51465
—	Dress Panel Assembly	AS4134-118			
—	Nameplate "4035"	NP22653-10			
—	Insert, Lower Screened	AD23089-1			
—	Spring, Window Retainer	AN51427			
—	End Strip, Right	AD23083-1			
—	End Strip, Left	AD23083-2			
CR508	L.E.D. STEREOBEACON	TR19001			
—	Tuning Shaft Assembly	AS20734			
—	Metal Poluter Assembly	AS20513			
—	Dial Plate	AS4130-109-2			
1101	Lamp, SQ (2187)	LM21421-4			
—	Lamp, CD-4/4-CH (2187)	LM21421-7			
M1	Meter, Signal	MC21627-2			
—	Meter, Clip	AB4130-123			
—	Pulley Bracket Assembly (Front Top)	AS4130-135			
—	Pulley Bracket	AB4130-120			
—	Pulley Bracket Assembly (Left Side)	AS4130-136			
—	Pulley Bracket	AS4130-121			
—	Pulley Idler	E50540-2			
	<b>REAR CHASSIS</b>				
—	Terminal Board	ET51340-2			
—	Antenna Terminal Strip	ET51549			
—	15 Jack Connector	JK25007			
—	AC Receptacle	JK25009			
—	Plate Fuse Holder	AM51409			
—	Fuse Holder	EA51408			
—	Fuse, 1½ Amp, 125V, Slo-Blo	FL51313-20			
—	Fuses (4), 1 Amp, 250V, Slo-Blo	FL51313-3			

\*Used on Export Models only.

## HARMONIC DISTORTION TEST

CAUTION: Limit the following tests to no more than ten minutes each. Use 8-ohm resistors with a minimum power rating of 50 watts when connecting a load across the speaker terminals. Connect a jumper wire across each of the speaker fuses while performing this test.

Control Settings: Unplug the AC power cord and set the front panel controls as follows:

BASS, TREBLE and BALANCE controls to center position. MODE SELECTOR "CD-4/4-CH" pushbutton depressed.  
SPEAKERS switch to AC OFF. LOUDNESS pushbutton out (not depressed).  
SELECTOR switch to AUX. VOLUME control to MIN.

### ONE CHANNEL DRIVEN:

- 1) Connect a low distortion audio oscillator to AUX IN FRONT LEFT jack. Set generator frequency to 1 kHz and output to minimum.
- 2) Connect an 8-ohm load resistor between FRONT SPEAKERS LEFT and COM terminals. Connect a Harmonic Distortion Analyzer and an AC VTVM in parallel across the 8-ohm load.
- 3) Connect the AC power cord and set the SPEAKERS switch to **4**. Increase VOLUME control to MAX.
- 4) Increase audio oscillator output to 10 watts RMS (8.8 volts RMS across the 8-ohm load). The meter on the Harmonic Distortion Analyzer should read less than 1.0%.
- 5) Repeat steps 1 through 4 for FRONT SPEAKERS RIGHT, REAR SPEAKERS LEFT, and REAR SPEAKERS RIGHT channels.

### ALL CHANNELS DRIVEN:

- 1) Connect an 8-ohm load resistor across all of the SPEAKER output terminals.
- 2) Depress the MODE SELECTOR "MONO" pushbutton.
- 3) Check for distortion of 1.0% or less at 10 watts RMS (8.8 volts RMS) on each channel with all channels driven simultaneously.
- 4) Disconnect all test equipment. Remove the jumper wires installed at the beginning of the test and replace the original fuses.

## TUNER ALIGNMENT

FM ALIGNMENT — BASS, TREBLE, and BALANCE controls to center positions, SPEAKERS switch to PHONES position, MODE SELECTOR "2-CH" pushbutton depressed, SELECTOR switch to FM position, and VOLUME control to MIN position.

Maintain generator output as low as possible for suitable indication.

ITEM	GENERATOR	DIAL SETTING	INDICATOR	PROCEDURE
<p><b>Note:</b> The FM IF circuit utilizes a non-tunable ceramic filter which establishes the IF bandpass. To insure symmetrical tuning and selectivity, the IF must be aligned precisely to the center of the filter bandpass, rather than to 10.7 MHz as in conventional LC circuits.</p>				
1. IF FM ALIGNMENT	Connect 10.7 MHz Sweep Generator to pin 63, ground to pin 5Y. Markers are not required. Set generator output to -10 dB (300 mv).	Position of non-interference. Connect jumper from pin 26 to pin 5R on Tuner board.	Scope vertical input to pin 57, ground to pin 5U. Set vertical sensitivity to 0.5v/cm.	Adjust Z502 top and bottom slugs for maximum gain and best symmetry. See figure for FM IF ALIGNMENT.
2. PRELIMINARY FM DETECTOR ALIGNMENT	Same as above. Adjust for S-curve display. Generator output to -20 dB.	Position of non-interference.	Scope vertical input to pin 58, ground to pin 5K.	Adjust Z503 top slug for maximum gain and best linearity. Adjust Z503 bottom slug for minimum gain and best linearity. See figure for FM DETECTOR ALIGNMENT. <b>Note:</b> Remove jumper from between pins 26 and 5R on Tuner board.
<p><b>Note:</b> Connect 120-ohm composition resistors in series with each lead from the RF generator to match the 50-ohm output to the 300-ohm input impedance. Generator output voltage is reduced to one-half at antenna terminals. Signal voltages specified in this table are generator output levels, not antenna voltages.</p>				
3. FRONT END FM ALIGNMENT		Tuning knob fully counterclockwise.		Center dial pointer on "0" and cement.

## TUNER ALIGNMENT

ITEM	GENERATOR	DIAL SETTING	INDICATOR	PROCEDURE
4.	FM generator to FM ANT terminals through 120-ohm resistors. Set to 90 MHz. Adjust output for approximately 2 on Field Strength meter.	Center of 90 MHz calibration mark on dial.	Front panel Field Strength meter.	Adjust L504, L502, and Z501 for maximum deflection on Field Strength meter. Reduce generator output to keep Field Strength meter indication at approximately 2.
5.	Set to 106 MHz.	Center of 106 MHz calibration mark on dial.	Front panel Field Strength meter.	Adjust C503, C509, and C518 for maximum deflection on Field Strength meter. Reduce generator output to keep Field Strength meter indication at approximately 2. Repeat steps 4 and 5 for optimum alignment.
6. FINAL FM DETECTOR ALIGNMENT (MINIMUM THD)	Set generator to receiver frequency. Modulate with 400 Hz ± 75 kHz deviation. Connect generator to FM ANT terminals.	Tune receiver to position of non-interference.	Scope vertical input to OUT TO RECORDER FRONT LEFT jack.	Reduce generator output for noise to be visible on sine wave. Readjust generator frequency to center noise on positive and negative half cycles. See figure for SYMMETRICAL TUNING.
<p><b>Note:</b> Upon completion of FINAL DETECTOR ALIGNMENT make no changes to generator or receiver tuning. Proceed with step 7.</p>				
7.	Same as above. Increase generator output to 2 mV.	Same as above.	AC VTVM and Harmonic Distortion Analyzer to OUT TO RECORDER FRONT LEFT jack.	Adjust Z503 top slug for maximum audio output. Adjust bottom slug for minimum THD. (Typically 0.2%.)
8A. MPX OSC ADJUSTMENT	Same as above.	Tune receiver to FM signal generator frequency.	Connect frequency counter to pin 72.	Adjust R559 for indication of 19 kHz (± 100 Hz).
8B. ALTERNATE MPX OSC ADJUSTMENT	Same as above.	Same as above.	Scope vertical input to pin 72. Scope horizontal input to MPX generator 19 kHz pilot output.	Adjust R559 for a stable Lissajou display as shown on figure for MPX OSCILLATOR ALIGNMENT.
<p>AM ALIGNMENT — BASS, TREBLE, and BALANCE controls to center positions, SPEAKERS switch to PHONES position, MODE SELECTOR "2-CH" pushbutton depressed, SELECTOR switch to AM position, and VOLUME control to MIN position.</p> <p>Maintain generator output as low as possible for suitable indication.</p>				
ITEM	GENERATOR	DIAL SETTING	INDICATOR	PROCEDURE
1. IF AM ALIGNMENT	455 kHz sweep generator to pin 70, ground to pin 5X.	Position of non-interference near 1400 kHz.	Scope vertical input to pin 61 ground to pin 5X. Set vertical sensitivity to 0.2 v/cm.	Connect a jumper between pin 67 and pin 5Z. Adjust Z302, Z303, and Z304 top and bottom slugs for maximum gain and best symmetry. Keep signal low enough for noise to appear on response as shown in figure for AM IF ALIGNMENT. Disconnect jumper.
2. FRONT END AM ALIGNMENT	AM generator to EXT AM ANT and GND terminals. Open GND link. Set to 600 kHz. Modulate with 400 Hz, 30% modulation.	Center of 600 kHz calibration mark on dial.	Front panel Field Strength meter.	Adjust Z301 and L300 (antenna) for maximum Field Strength meter indication. Reduce generator output to keep meter reading below 3.
3.	Set to 1400 kHz.	Center of 1400 kHz calibration mark on dial.	Front panel Field Strength meter.	Adjust C303 and C304 for maximum deflection. Keep meter reading below 3. Repeat steps 2 and 3 until optimum alignment is reached.

# TUNER SCHEMATIC

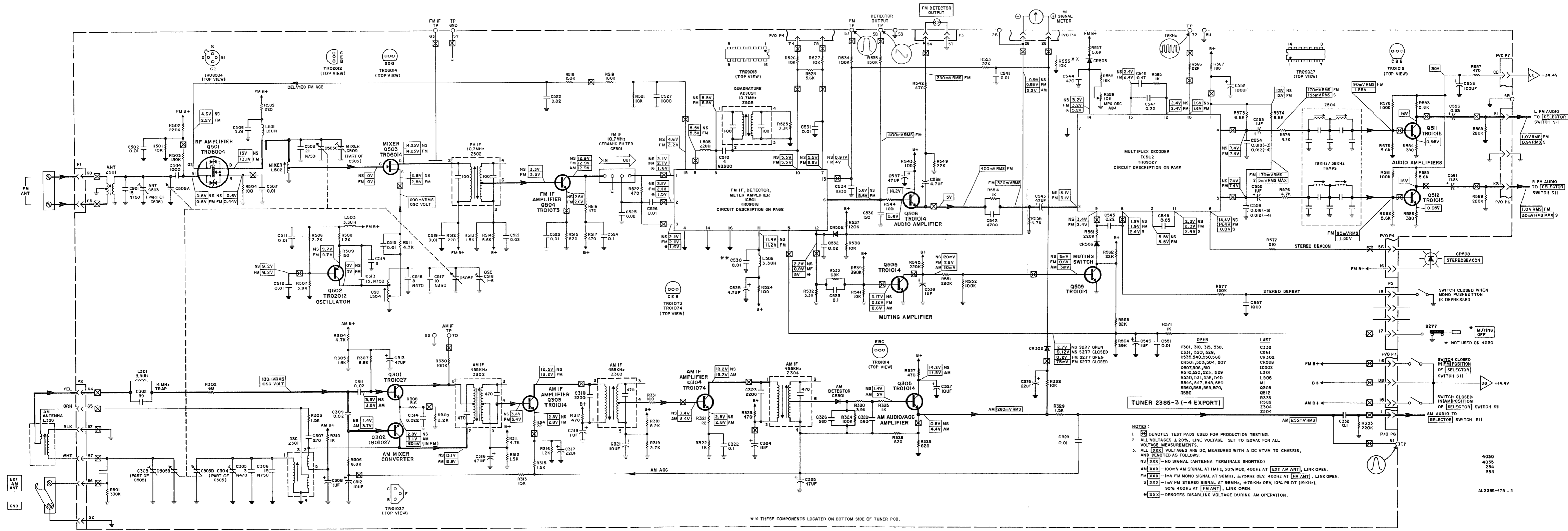

TUNER 2385-3 (-4 EXPORT)

- NOTES:
- ⊗ DENOTES TEST PADS USED FOR PRODUCTION TESTING.
  - ALL VOLTAGES ± 20% LINE VOLTAGE SET TO 120VAC FOR ALL VOLTAGE MEASUREMENTS.
  - ALL [XXX] VOLTAGES ARE DC, MEASURED WITH A DC VTVM TO CHASSIS, AND DENOTES AS FOLLOWS:  
 NS [XXX] - NO SIGNAL (ANTENNA TERMINALS SHORTED)  
 AM [XXX] - 100mV AM SIGNAL AT 1MHz, 30% MOD, 400Hz AT [EXT AM ANT], LINK OPEN.  
 FM [XXX] - 1mV FM MONO SIGNAL AT 98MHz, ± 75kHz DEV, 400Hz AT [FM ANT], LINK OPEN.  
 S [XXX] - 1mV FM STEREO SIGNAL AT 98MHz, ± 75kHz DEV, 10% PILOT (19kHz), 90% 400Hz AT [FM ANT], LINK OPEN.  
 \* [XXX] - DENOTES DISABLING VOLTAGE DURING AM OPERATION.

\*\* THESE COMPONENTS LOCATED ON BOTTOM SIDE OF TUNER PCB.



## TUNER PARTS LIST

Ref. Des.	Description	Part Number	Ref. Des.	Description	Part Number
C302	Ceramic, 39 pF, N330, 50V	CK22344-22	L301, 503, 506	Choke, RF, 3.3 uH	LC21814-2
C303, 304	P/O C505	—	L501	Choke, RF, 1.2 uH	LC21822-2
C305	Ceramic, 3 pF, ±0.25 pF, N470	CK22346-4	L502	Coil, FM MIXER	LC21833-2
C306, 501, 513	Ceramic, 15 pF, 5%, 50V, N750	CK22344-2	L504	Coil, FM OSCILLATOR	LC21833-1
C307	Ceramic, 270 pF, 10%, 50V	CK22350-5	L505	Choke, RF, 22 uH	L50848-18
C308, 319, 324, 539, 549, 553, 555	Electrolytic, 1 uF, 50V	CE22342-2	M1	Meter, Field Strength	MC21627-2
C309, 311, 521, 522, 525, 532	Ceramic, 0.02 uF, +80 -20%, 50V	CK22354-2	Q301, 302	Transistor, NPN (A494/BF194)	TR01027
C312, 321, 327	Electrolytic, 10 uF, 50V	CE22342-4	Q303, 305, 505, 506, 509	Transistor, NPN (BC239C)	TR01014
C313, 316, 325, 537	Electrolytic, 47 uF, 16V	CE22342-8	Q304	Transistor, NPN (BF199)	TR01074
C314	Mylar, 2200 pF, 10%, 50V	CY22356-9	Q501	Transistor, Dual-Gate MOSFET	TR08004
C317, 329	Electrolytic, 22 uF, 35V	CE22342-6	Q502	Transistor, PNP (SP871)	TR02012
C318, 323	Polystyrene, 2200 pF, 5%, 33V	C51256-30	Q503	Transistor, FET	TR06014
C320, 326	Ceramic, 560 pF, 10%, 50V	CK22350-9	Q504	Transistor, NPN (BF198)	TR01073
C322, 524, 533	Ceramic, 0.1 uF, +80 -20%, 50V	CK22354-3	Q511, 512	Transistor, NPN	TR01015
C328, 502, 506, 507, 511, 512, 515, 519, 523, 526, 528, 531, 541, 551	Ceramic, 0.01 uF, +80 -20%, 50V	CK22354-1	R301	330K	RF25DC334J
C332	Mylar, 0.1 uF, 10%, 50V	CY22356-11	R302	68	RF25DC680J
C503	P/O C505	—	R303, 305, 312, 315, 329, 513	4.7K	RF25DC152J
C504, 527, 534, 557	Ceramic, 1000 pF, 10%, 50V	CK22350-12	R304, 311, 511, 556, 575, 576	6.8K	RF25DC682J
C505	Tuning Gang Assembly	CV21015	R306, 307, 573, 574	5.6	RF25DC5R6J
C508	Ceramic, 21 pF, 10%, 50V, N750	CK22345-15	R308	2.2K	RF25DC222J
C509	P/O C505	—	R309, 506	1K	RF25DC102J
C510	Tubular, 4 pF, ±0.25 pF, N3300	CT22336-11	R310, 322, 325, 554, 565, 571	15K	RF25DC153J
C514	Ceramic, 8 pF, 5%, 50V, NPO	CK22344-5	R313	22	RF25DC220J
C516	Tubular, 8 pF, 5%, N220	CT22336-13	R314, 321	1.2K	RF25DC122J
C517	Tubular, 10 pF, 5%, N330	CT22336-14	R316, 508	470	RF25DC470J
C518	Trimmer, 1-6 pF	C50B938-5	R317, 323, 327, 516, 517, 522, 542, 587	8.2K	RF25DC822J
C528, 538, 543	Electrolytic, 4.7 uF, 50V	CE22342-3	R318	2.7K	RF25DC272J
C536	Ceramic, 150 pF, 10%, 50V	CK22350-2	R319	3.9K	RF25DC392J
C542	Ceramic, 4700 pF, 10%, 50V	CK22347-22	R320, 507	100K	RF25DC104J
C544	Silvered Mica, 470 pF, 5%, 50V	CA22313-1	R324, 330, 519, 534, 552, 578, 581	820	RF25DC821J
C545, 547	Mylar, 0.22 uF, 10%, 50V	CY22356-12	R326, 328, 515	100	RF25DC101J
C546	Sintered Aluminum, 0.47 uF, 20%	CS22340-4	R331, 504, 524, 543, 544	10K	RF25DC103J
C548	Polyester, 0.05 uF, 10%, 100V	CY22335-5	R332, 501, 521, 526, 527, 538, 541, 555	220K	RF25DC224J
C552	Electrolytic, 100 uF, 16V	CE22342-12	R333, 502, 545, 551, 561, 588, 589	150K	RF25DC154J
C554, 556	Polyester, 0.018 uF, 10%, 100V	CY22335-10	R503, 518, 535	220	RF25DC221J
C558	Electrolytic, 100 uF, 35V	C22342-10	R505, 512	150	RF25DC151J
C559, 561	Tantalum, 0.33 uF, 35V	CL22305-9	R509	5.6K	RF25DC562J
CF501	Filter, Ceramic, 10.7 MHz	ZK22110	R514, 529, 557, 579, 582, 583, 585	3.3K	RF25DC332J
CR301, 502	Diode, Germanium (AA119)	TR12001-4	R525, 532	68K	RF25DC683J
CR302, 505, 506	Diode, Silicon	TR13006-2	R533	120K	RF25DC124K
CR508	Light Emitting Diode (LED) - STEREOBEACON	TR19001	R537, 577	390K	RF25DC394J
IC501	Integrated Circuit - FM IF	TR09018	R539		
IC502	Integrated Circuit - MPX DECODER	TR09027			
L300	Antenna, AM Ferrite	LA51417-2			

## TUNER PARTS LIST (CONTINUED)

Ref. Des.	Description	Part Number	Ref. Des.	Description	Part Number
R549, 553, 562, 566	22K	RF25DC223J	Z303	Transformer, AM IF Interstage	ZZ50210-156
R558	16K	RF25DC163J	Z304	Transformer, IF Output	ZZ50210-159
R559	Variable, 10K, 20%	RV50150-23-7	Z501	Coil, FM Antenna	LC21832
R563	82K	RF25DC823J	Z502	Transformer, FM IF	ZZ50210-146
R564	39K	RF25DC393J	Z503	Transformer, FM IF	ZZ50210-180
R567	180	RF25DC181J	Z504	Filter, Dual Multiplex, 15 KHz	ZZ50210-190
R572	Composition, 510, 5%, 1/2W	RC20BF511J	—	Terminal Board, Antenna (FM ANT, EXT AM ANT)	ET51459
R584, 586	390	RF25DC391J	All resistors are deposited film, 5%, 1/4W unless otherwise noted. K = Kilohm.		
S11	Switch, SELECTOR	SR4130-151			
Z301	Coil, AM Oscillator	ZZ50210-181			
Z302	Transformer, AM IF Input	ZZ50210-161			

## TUNER BOARD LAYOUT

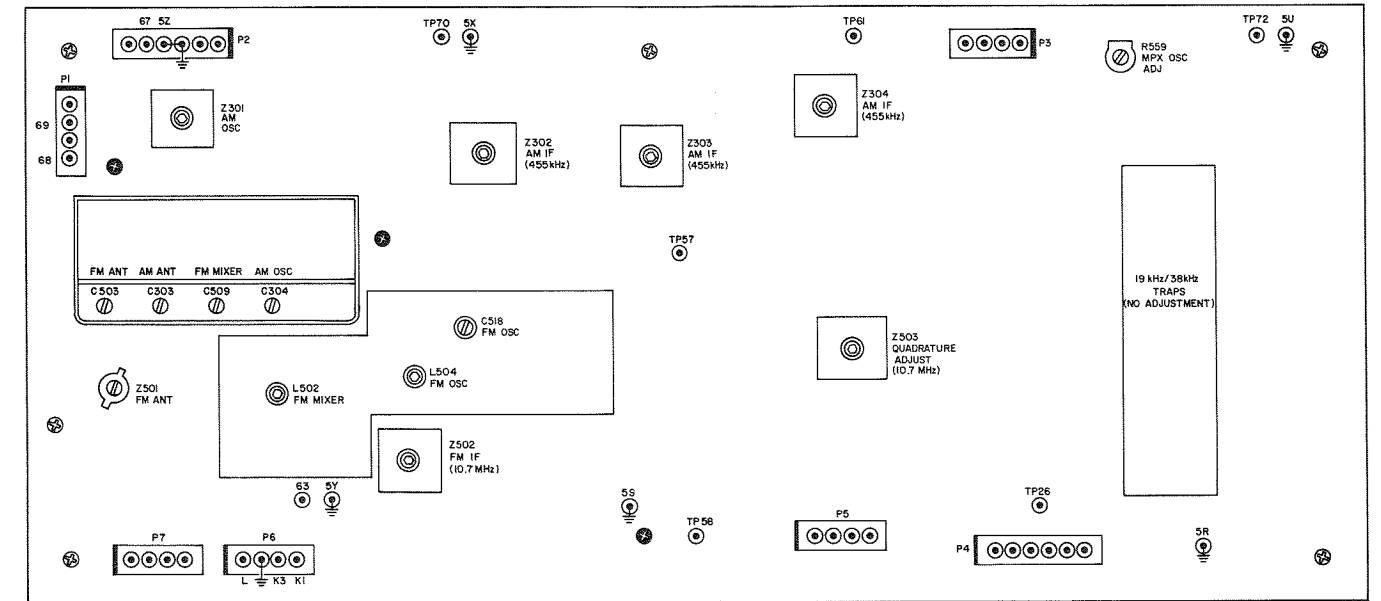

NOTE: CHASSIS GROUNDS ARE COMPLETED THROUGH MOUNTING SCREWS (S). TIGHTEN BEFORE ATTEMPTING ALIGNMENT.

AL 2385 - 177

## TUNER ALIGNMENT WAVEFORMS

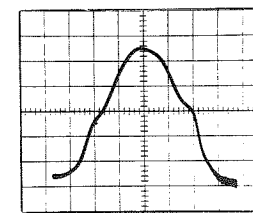

FM IF ALIGNMENT.

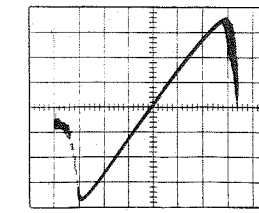

FM DETECTOR ALIGNMENT

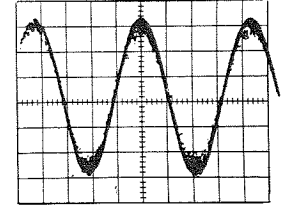

SYMMETRICAL TUNING

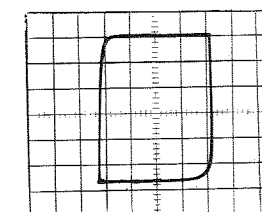

MPX OSC ADJUSTMENT

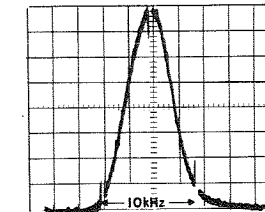

AM IF ALIGNMENT

## TUNER IC SIGNAL FLOW

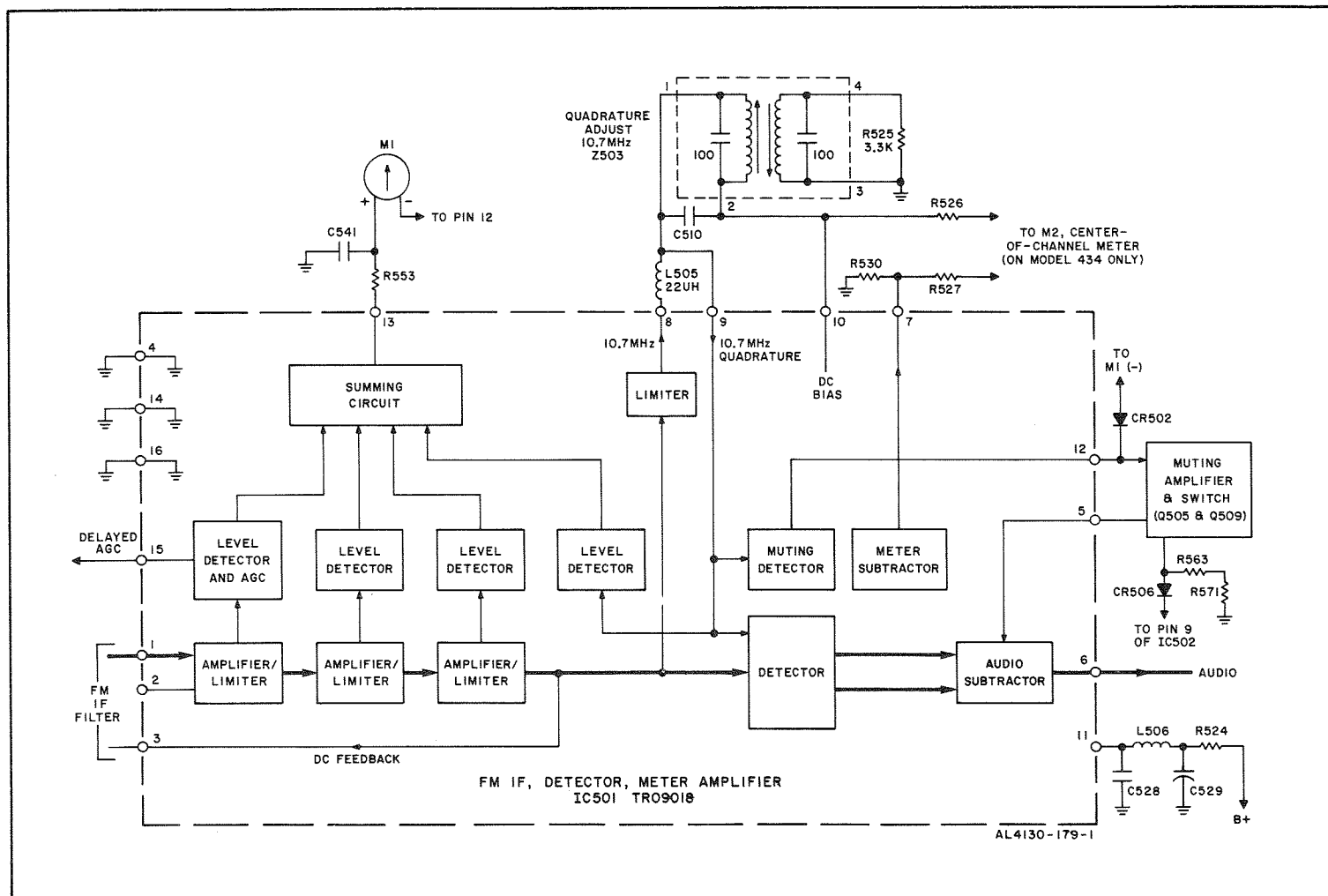

## TUNER IC DESCRIPTION

### IF DETECTOR IC

The input from the IF filter is processed through three states of amplification and limiting. The output of the third limited is applied to a fourth limiter, and a balanced detector. The push-pull output from the detector is combined differentially in the subtractor stage to produce an audio output at pin 6.

The output from the fourth limiter is applied through L505 to tuned circuit Z503. At the exact center of the IF passband (nominally 10.7 MHz), Z503 is preset to provide a 10.7 MHz quadrature (90 degrees out-of-phase) signal to the detector. The phase of the signal from the tuned circuit changes proportionally with changes in the frequency of the IF signal. With no audio modulation, the inputs of the detector are in quadrature and the outputs of the detector are balanced. No differential signals appear at the outputs of the subtractor stages. When the frequency on the IF signal deviates from 10.7 MHz (as a result of audio modulation or station detuning), the de-

tor outputs are unbalanced and a differential DC signal appears at pin 6.

The muting detector (pin 12) monitors the envelope signal-to-noise ratio across the tuned circuit and feeds the detected noise to the muting amplifier and switch. Excessive noise in the signal generates a control voltage which is amplified and applied to pin 9 of IC502 to force the receiver into monophonic operation.

Level detectors monitor the IF signal levels at the three amplifier/limiter stages and at the tuned circuit. Each limiter, beginning with the last, saturates progressively as the input level increases. Rectified signals from the level detectors are summed and applied (pin 13) as a linear-log voltage to the Field Strength meter.

An AGC voltage (pin 15) for the RF amplifier is obtained from the first level detector. This AGC voltage is delayed until the IF signal in the first amplifier approaches limiting.

## TUNER IC SIGNAL FLOW

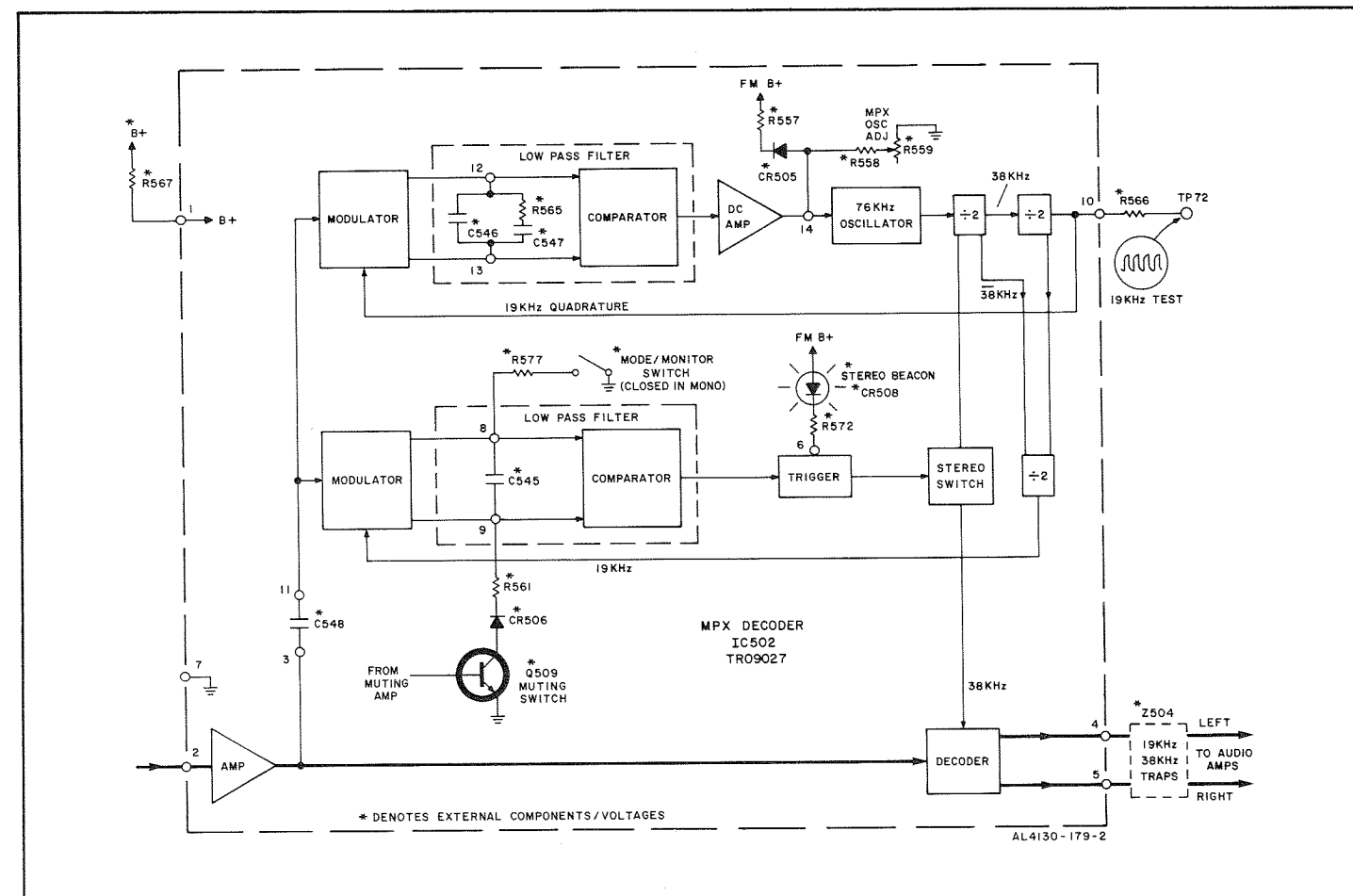

## TUNER IC DESCRIPTION

### MPX DECODER IC

When the receiver is tuned to a stereo broadcast the composite audio fed to pin 2 consists of sum-and-difference signal information (L+R and L-R), and a 19 kHz pilot tone. The L+R information is in the form of normal audio. The L-R information is Amplitude Modulated on a suppressed 38 kHz sub-carrier. (At the transmitter, the subcarrier is derived from the pilot tone through a frequency-doubler.) In order to extract the L-R information, it is necessary to regenerate the 38 kHz subcarrier and apply it, together with the composite signal, to the decoder. Left and Right channel information is then decoded by addition and subtraction of the L+R and L-R information.

The top line of the block diagram shows the 38 kHz subcarrier regeneration loop. The 76 kHz oscillator output is processed through two frequency divider stages to furnish 38 kHz and 19 kHz outputs. The 19 kHz output is a quadrature (90° out-of-phase) signal which is applied to the modulator. When the composite input signal contains a 19 kHz pilot tone (stereo broadcast) the 19 kHz quadrature signal is phase-compared to the pilot signal and the resulting DC voltage fed through the DC amp to the oscillator,

where it corrects the frequency. As a result, the oscillator is continuously phase-locked to the pilot signal. The setting of R559 determines the frequency of the free-running oscillator. With the oscillator phase-locked to the pilot, the 38 kHz output from the first divider is in the correct phase for decoding a stereo signal. The regenerated 38 kHz signal is fed to the decoder via a stereo switch. The stereo switch closes when a sufficiently large 19 kHz pilot tone is detected in the second modulator-comparator circuit. A third frequency divider stage, which processes signals derived from the first two dividers, returns a 19 kHz in-phase signal to the second modulator-comparator for pilot detection. The DC voltage derived from the second modulator-comparator circuit is applied to the trigger which activates the STEREO-BEACON indicator and the stereo switch.

The circuit is forced into the monophonic mode by grounding pin 8, or by applying a positive DC voltage to pin 9. With very low-level, noisy FM signals, a positive voltage from pin 12 of IC501 is amplified without change of polarity and applied to pin 9 of IC502 forcing the circuit into mono operation. During AM operation pin 14 is effectively grounded thus disabling the 76 kHz oscillator and eliminating interference.

# CD-4 DEMODULATOR SCHEMATIC

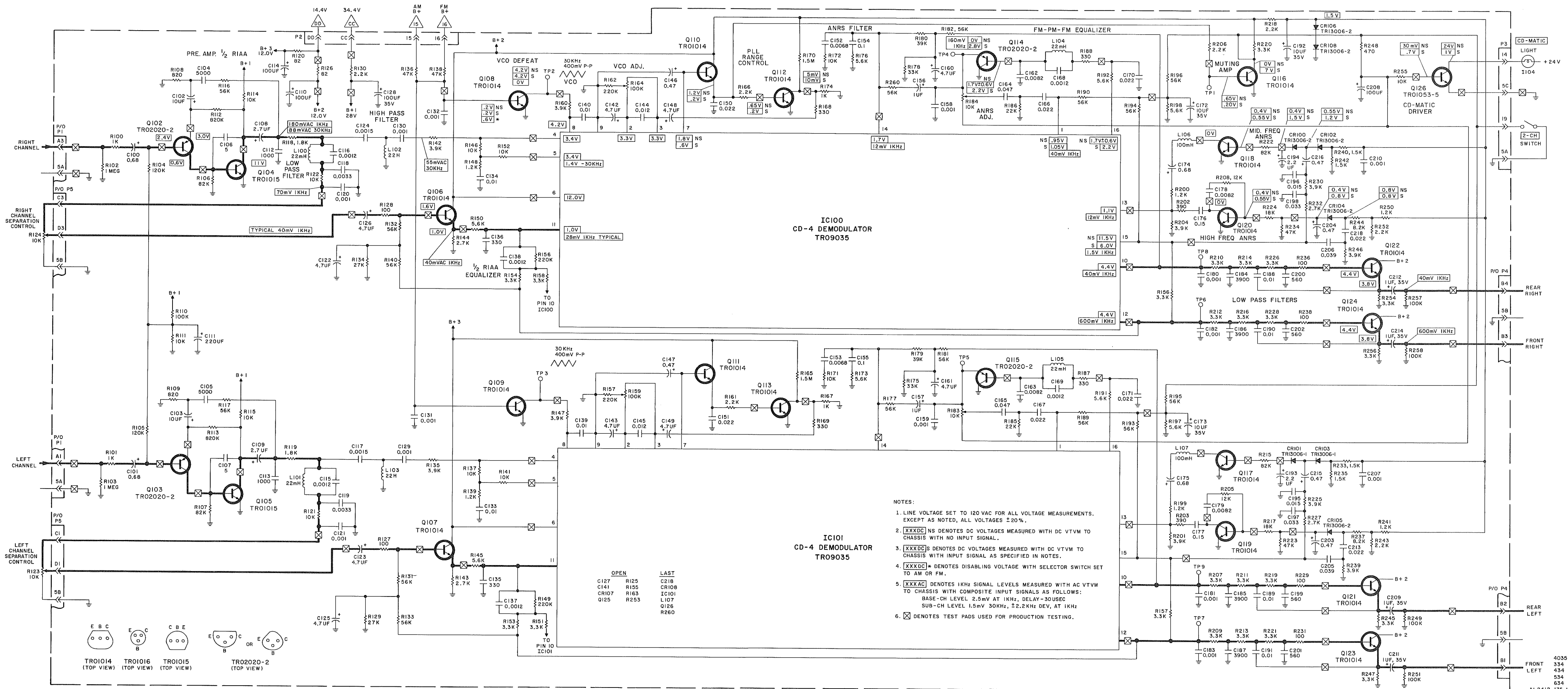

## CD-4 ALIGNMENT

APPLICABLE CONTROL SETTINGS — Set the applicable controls on the front panel of the receiver as follows:

SELECTOR switch to PHONO/CD-4, MODE SELECTOR CD-4/4-CH pushbutton depressed, and VOLUME control to MIN.

ITEM	TEST CONNECTIONS	INDICATOR	PROCEDURE
1. ANRS ALIGNMENT	Connect audio oscillator to T P 5 on PB2412 circuit board. Set oscillator output to 25 mV and frequency to 10 kHz.	AC VTVM to OUT TO RECORDER-FRONT LEFT jack on receiver rear panel.	Defeat the muting circuit by grounding T P 1 on PB2412 circuit board. Set LEFT and RIGHT SEPARATION controls (R123 and R124) at front panel of receiver to minimum (fully counterclockwise). Adjust R183 for 17.5 mV reading on the meter.
2.	Connect audio oscillator to T P 4 on PB2412 circuit board. Set oscillator output to 25 mV and frequency to 10 kHz.	AC VTVM to OUT TO RECORDER-FRONT RIGHT jack on receiver rear panel.	Adjust R184 for a reading of 17.5 mV on the meter.
3. VCO ALIGNMENT	Connect oscilloscope and frequency counter to T P 3 on PB2412 circuit board.	Scope display will be a triangular waveform 400 mV peak-to-peak.	Retain the ground connection made in step 1 to defeat the muting circuit. Using two RCA shorting plugs, short out PHONO IN LEFT and RIGHT jacks. Adjust R159 for a 30 kHz $\pm$ 200 Hz indication on the frequency counter.
4.	Connect oscilloscope and frequency counter to T P 2 on PB2412 circuit board.	Scope display will be a triangular waveform 400 mV peak-to-peak.	Adjust R164 for a 30 kHz $\pm$ 200 Hz indication on the frequency counter.
5. VCO ALIGNMENT (ALTERNATE METHOD)	Connect frequency indicator (Fisher 3129 or equivalent) to T P 3 on PB2412 circuit board.		Adjust R159 for full brightness of indicator lamp on the frequency indicator.
6.	Connect frequency indicator to T P 2 on PB2412 circuit board.		Adjust R164 for full brightness of indicator lamp on frequency indicator. Remove ground connection from T P 1 (muting circuit) and remove shorting plugs from PHONO IN jacks.
7. SEPARATION ALIGNMENT	Connect CD-4 Generator to PHONO IN LEFT and RIGHT jacks on rear panel of receiver. Set generator output as follows:  Sub-Channel carrier level . . . . . 1.5 mV Channel Selector . . . . . FRONT Deviation . . . . . 2.2 kHz Base Channel . . . . . 2.2 mV Input Frequency . . . . . 1 kHz Delay . . . . . 40 usec.	Connect AC VTVM to OUT TO RECORDER-REAR LEFT jack on rear panel of receiver. CD-MATIC indicator lamp on front panel of receiver should be illuminated.	Adjust LEFT CD-4 SEPARATION control (R123) at receiver front panel for minimum reading on the meter.
8.	Same as above	Connect AC VTVM to OUT TO RECORDER-REAR RIGHT jack on rear panel of receiver.	Adjust RIGHT CD-4 SEPARATION control (R124) at receiver front panel for minimum reading on the meter.
9. LEFT CHANNEL SEPARATION	Connect AC VTVM to OUT TO RECORDER-FRONT LEFT jack on rear panel of receiver.	AC VTVM	Meter reading should be 500 mV $\pm$ 150 mV. Record this reading as zero dB.
10.	Connect AC VTVM to OUT TO RECORDER-REAR LEFT jack on rear panel of receiver.	AC VTVM	Meter reading should be at least 20 dB below zero dB reading recorded in step 9.
11. RIGHT CHANNEL SEPARATION	Connect AC VTVM to OUT TO RECORDER-FRONT RIGHT jack on rear panel of receiver.	AC VTVM	Meter reading should be 500 mV $\pm$ 150 mV. Record this reading as zero dB.
12.	Connect AC VTVM to OUT TO RECORDER-REAR RIGHT jack on rear panel of receiver.	AC VTVM	Meter reading should be at least 20 dB below zero dB reading recorded in step 11.

NOTE: Upon completion of CD-4 Alignment disconnect all test equipment and replace RCA shorting plugs in PHONO IN-LEFT and RIGHT jacks.

## CD-4 DEMODULATOR PARTS LIST

Ref. Des.	Description	Part Number	Ref. Des.	Description	Part Number
C100, 101, 174, 175	Tantalum, 0.68 uF, 35V	CL22305-2	L106, L107	Inductor, audio, 100 mH	LC21834-1
C102, 103	Tantalum, 10 uF, 25V	CL22305-17	Q102, 103, 114, 115	Transistor, PNP (2N4250)	TR02020-2
C104, 105	Mylar, 5000 pF, 5%	CY22356-28	Q104, 105	Transistor, NPN	TR01015
C106, 107	Ceramic, 5 pF, 5%, NPO, 50V min.	CK22344-1	Q106 thru 113, Q116 thru 124	Transistor (BC239C)	TR01014
C108, 109	Tantalum, 2.7 uF, 35V	CL22305-4	Q126	Transistor, NPN	TR01053-5
C110, 114, 208	Electrolytic, 100 uF, 16V	CE22342-12	R100, 101, 167, 174	1K	RF25DC102J
C111	Electrolytic, 220 uF, 16V	CE22342-15	R102, 103	1M	RF25DC105J
C112, 113, 120, 121, 129, 130, 131, 132, 158, 159, 180, 181, 182, 183, 207, 210	Ceramic, 1000 pF, 10%, 50V	CK22350-12	R104, 105	120K	RF25DC124J
C115, 116, 137, 138, 168, 169	Mylar, 0.0012, 10%, 100V	CY22335-23	R106, 107, 215, 222	82K	RF25DC823J
C117, 124	Mylar, 1500 pF, 10%, 100V	CY22335-24	R108, 109	820	RF25DC821J
C118, 119	Mylar, 3300 pF, 10%, 100V	CY22335-7	R110, 249, 251, 257, 258	100K	RF25DC104J
C122, 123, 125, 126, 142, 143, 148, 149	Sintered Aluminum, 4.7 uF, 25V	CS22340-6	R111, 114, 115, 121, 122, 137, 141, 146, 152, 171, 172, 255	10K	RF25DC103J
C128	Electrolytic, 100 uF, 35V	CE22342-10	R112, 113	820K	RF25DC824J
C133, 134, 139, 140, 188, 189, 190, 191	Mylar, .01, 10%, 100V	CY22335-1	R116, 117, 131, 132, 133, 140, 177, 181, 182, 189, 190, 193, 194, 195, 196, 260	56K	RF25DC563J
C135, 136	Ceramic, 330 pF, 10%, 50V	CK22350-6	R118, 119	1.8K	RF25DC182J
C144, 145	Mylar, 0.012, 10%, 100V	CY22335-10	R120, 126	82, 1/2W	RF50DC820J
C146, 147, 203, 204, 215, 216	Sintered Aluminum, 0.47 uF, 25V	CS22340-4	R123, 124	Potentiometer, 10K, Rotary	RF50160-317
C150, 151, 166, 167, 170, 171, 213, 218	Mylar, 0.022, 10%, 100V	CY22335-12	R127, 128, 229, 231, 236, 238	100	RF25DC101J
C152, 153	Mylar, 6800 pF, 100V	CY22335-9	R129, 134	27K	RF25DC273J
C154, 155	Mylar, 0.1, 10%, 100V	CY22335-18	R130, 161, 166, 206, 218, 243, 252	2.2K	RF25DC222J
C156, 157, 209, 211, 212, 214	Sintered Aluminum, 1 uF, 25V	CS22340-6	R135, 142, 147, 160, 201, 204, 225, 230, 239, 246	3.9K	RF25DC392J
C160, 161, 162, 163, 178, 179	Electrolytic, 4.7 uF, 50V	CE22342-3	R136, 138, 223, 234	47K	RF25DC473J
C164, 165	Mylar, 0.047, 10%, 100V	CY22335-22	R139, 148, 199, 200, 241, 250	1.2K	RF25DC122J
C172, 173, 192	Electrolytic, 10 uF, 35V	CE22342-28	R143, 144, 227, 232	2.7K	RF25DC272J
C176, 177	Mylar, 0.15, 10%, 100V	CY22335-19	R145, 150, 173, 176, 191, 192, 197, 198	5.6K	RF25DC562J
C184, 185, 186, 187	Mylar, 3900 pF, 10%, 100V	CY22335-4	R149, 156, 157, 162	220K	RF25DC224J
C193, 194	Sintered Aluminum, 2.2 uF, 25V	CS22340-10	R151, 153, 154, 158, 209, 212, 213, 216, 221, 228, 207, 210,	3.3K	RF25DC332J
C195, 196	Mylar, .015, 10%, 100V	CY22335-2			
C197, 198	Mylar, 0.033, 10%, 100V	CY22335-14			
C199, 200, 201, 202	Ceramic, 560 pF, 10%, 50V	CK22350-9			
C205, 206	Mylar, 0.039, 10%, 100V	CY22335-15			
CR100	Silicon Diodes	TR13006-2			
CR108					
IC100, 101	CD-4 IC Demodulator	TR09035			
L100 thru L105	Inductor, audio, 22 mH	LC21834-2			

## CD-4 DEMODULATOR PARTS LIST

(CONTINUED)

Ref. Des.	Description	Part Number	Ref. Des.	Description	Part Number
211, 214, 219, 220, 226, 245, 247, 254, 256	Resistor, variable, 100K	RV50150-23-8	R179, 180	39K	RF25DC393J
R159, 164	1.5M	RF25DC155J	R183, 184	Resistor, variable, 10K	RV50150-23-7
R165, 170	330	RF25DC331J	R185, 186	22K	RF25DC223J
R168, 169, 187, 188			R202, 203	390	RF25DC391J
R175, 178	33K	RF25DC333J	R205, 208	12K	RF25DC123J
			R217, 224	18K	RF25DC183J
			R233, 235, 240, 242	1.5K	RF25DC152J
			R237, 244	8.2K	RF25DC822J
			R248	470	RF25DC471J

All resistors are deposited film, 5%, 1/4W unless otherwise noted.  
K = Kilohm, M = Megohm

## CD-4 DEMODULATOR BOARD LAYOUT

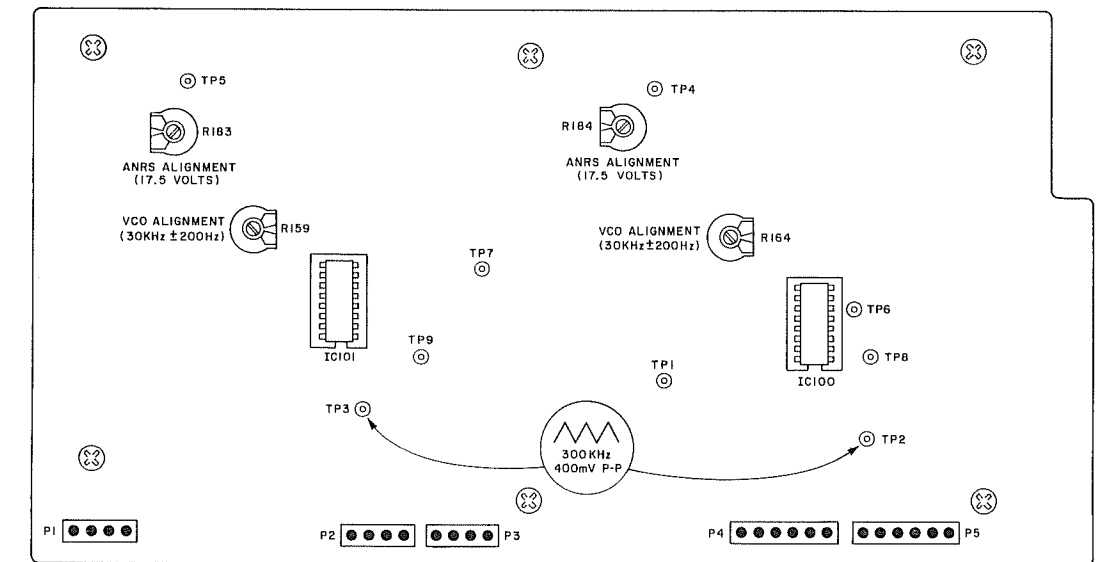

AL4134-177-1

## SQ DECODER PARTS LIST

Ref. Des.	Description	Part Number	Ref. Des.	Description	Part Number
C31, 32, 33, 34	Ceramic, 470 pF, 10%, 50V	CK22345-9	R101, 102, 103, 104	47K	RF25DC473J
C101, 102	Ceramic, 0.05 uF, +80 -20%, 100V	CK22362-4	R105, 106, 107, 108	120K	RF25DC124J
C103, 104	Sintered Aluminum, 0.33 uF, 25V	CS22340-3	R109, 110, 111, 112	18K	RF25DC183J
C105, 106	Tantalum, 1.0 uF, 35V	CL22305-3	R113, 114	68K	RF25DC683J
C108, 124	Electrolytic, 100 uF, 35V	CE22342-10	R115, 116, 117, 118	150K	RF25DC154J
C109, 110, 113, 114	Mylar, 0.039 uF, 5%, 50V	CY22356-16	R121, 122	4.7K	RF25DC472J
C111, 112	Mylar, 6800 pF, 5%, 50V	CY22356-2	R123, 124, 135, 136, 137, 138, 139, 140	1M	RF25DC105J
C115, 116	Mylar, 0.22 uF, 5%, 50V	CY22356-17	R127, 128, 133, 134	3.6K	RF25DC362J
C117, 118, 119, 120, 121, 122	Sintered Aluminum, 1.0 uF, 25V	CS22340-5	R129, 130, 131, 132	4.3K	RF25DC432J
IC101	Integrated Circuit, Four Channel S.Q. Decoder	TR09032	R141	7.5K	RF25DC752J
Q101, 102	Transistor, BC147B	TRBC147B	R142	Wirewound, 1K, 2W	RW200W102J
R34, 35, 36, 37, 119, 120, 126	1K	RF25DC102J	S101	Switch, Mode Selector	SP0200-72-1

Note: All resistors are deposited film, 5%, 1/4W unless otherwise noted. K = Kilohm, M = Megohm.



# SQ DECODER SCHEMATIC

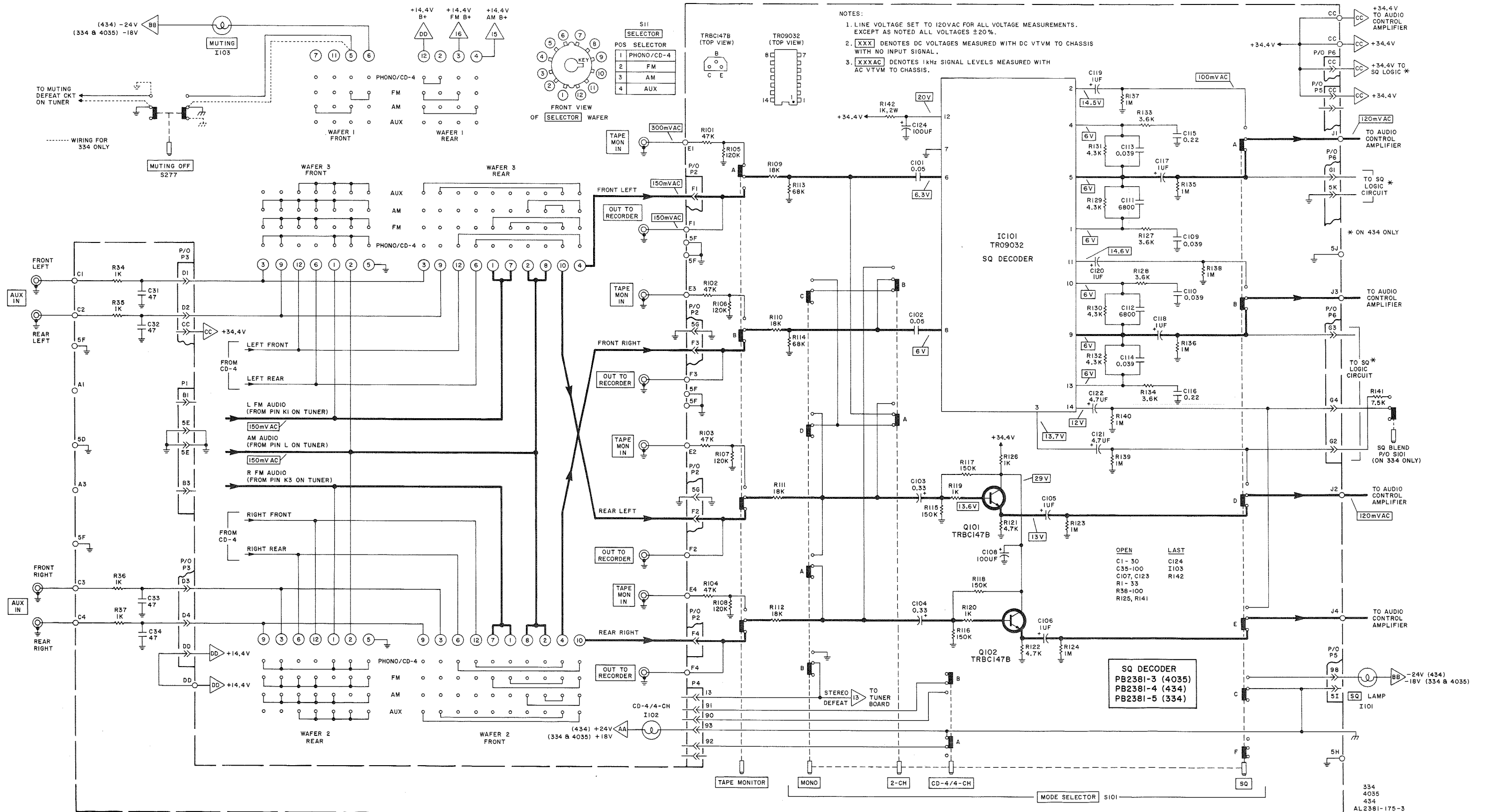

# AUDIO CONTROL AMPLIFIER SCHEMATIC

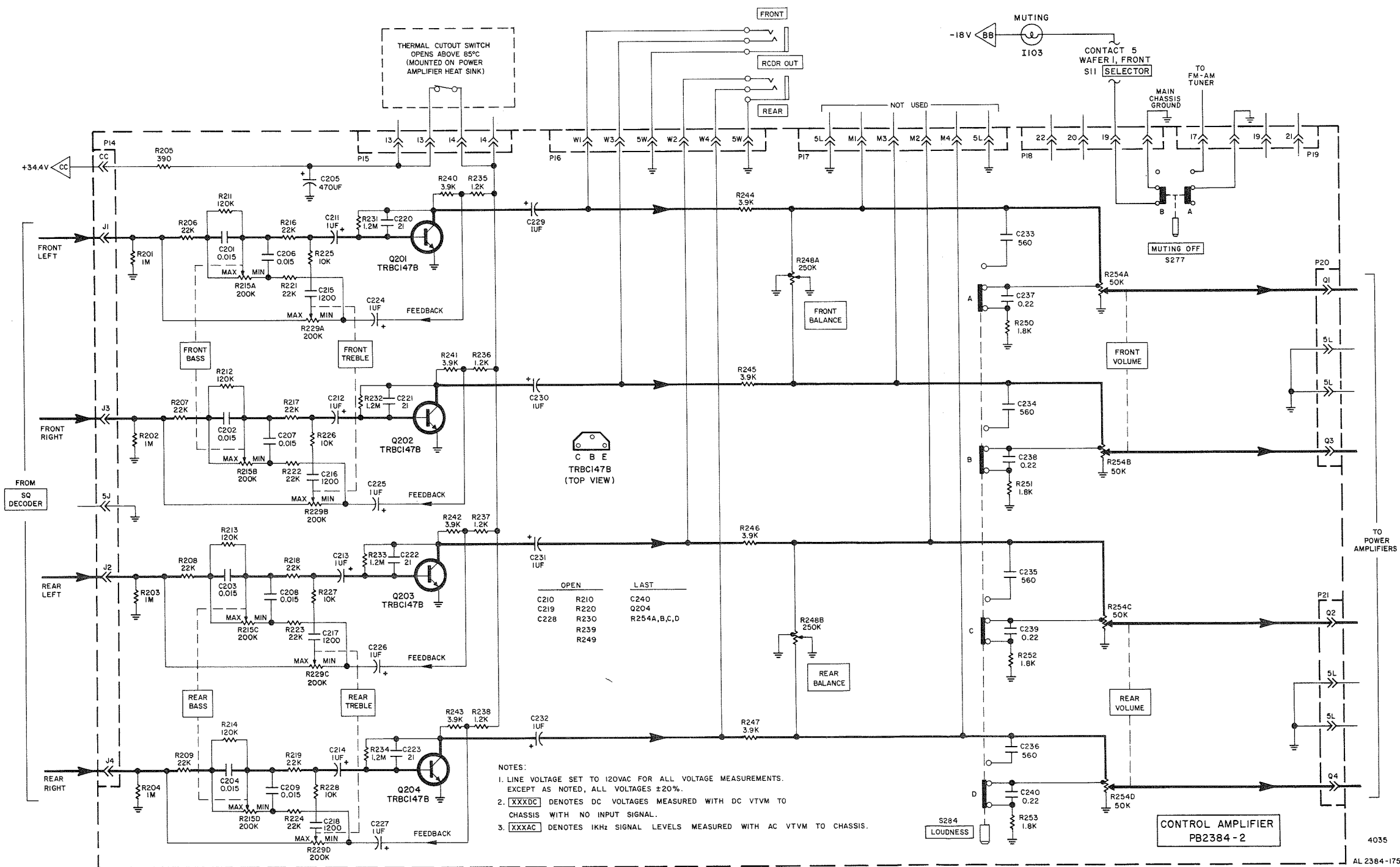

NOTES:  
 1. LINE VOLTAGE SET TO 120VAC FOR ALL VOLTAGE MEASUREMENTS. EXCEPT AS NOTED, ALL VOLTAGES  $\pm 20\%$ .  
 2. [XXXDC] DENOTES DC VOLTAGES MEASURED WITH DC VTVM TO CHASSIS WITH NO INPUT SIGNAL.  
 3. [XXXAC] DENOTES 1kHz SIGNAL LEVELS MEASURED WITH AC VTVM TO CHASSIS.

## AUDIO CONTROL AMPLIFIER PARTS LIST

Ref. Des.	Description	Part Number
C201, 202, 203, 204, 206, 207, 208, 209	Mylar, 0.015 $\mu$ F, 10%, 50V	CY22356-21
C205	Electrolytic, 470 $\mu$ F, 35V	CE22343-34
C211, 212, 213, 214	Sintered Aluminum, 1 $\mu$ F, 25V	CS22340-5
C215, 216, 217, 218	Ceramic, 1200 pF, 10%, 50V	CK22350-17
C220, 221, 222, 223	Ceramic, 21 pF, N470, 5%, 50V	CK22344-16
C224, 225, 226, 227, 229, 230, 231, 232	Tantalum, 1 $\mu$ F, 35V	CL22305-3
C233, 234, 235, 236	Ceramic, 560 pF, 10%, 50V	CK22350-9
C237, 238, 239, 240	Mylar, 0.22 $\mu$ F, 10%, 50V	CY22356-12
Q201, 202, 203, 204	Transistor, NPN (BC147B)	TRBC147B
R201, 202, 203, 204	1M	RF25DC105J
R205	390, 5%, $\frac{1}{2}$ W	RF50DC391J
R206, 207, 208, 209, 216, 217, 218, 219, 221, 222, 223, 224	22K	RF25DC223J
R211, 212, 213, 214	120K	RF25DC124J
R215 (A,B,C,D) 229 (A,B,C,D)	Potentiometer, 200K, Rotary (Bass, Treble)	RP50160-313
R225, 226, 227, 228	10K	RF25DC103J
R231, 232, 233, 234	1.2M	RF25DC125J
R235, 236, 237, 238	1.2K	RF25DC122J
R240, 241, 242, 243, 244, 245, 246, 247	3.9K	RF25DC392J
R248 (A,B)	Potentiometer, 250K, Rotary (Balance)	RP50160-314
R250, 251, 252, 253	1.8K	RF25DC182J
R254 (A,B,C,D)	Potentiometer, 50K, Rotary (Volume)	RP50160-312
S277	Pushbutton Switch (MUTING OFF)	P/O SP50200-75-1
S284	Pushbutton Switch (LOUDNESS)	P/O SP50200-75-1

All resistors are deposited film, 5%,  $\frac{1}{2}$ W unless otherwise noted.  
 K = Kilohm, M = Megohm.

# POWER AMPLIFIER SCHEMATIC

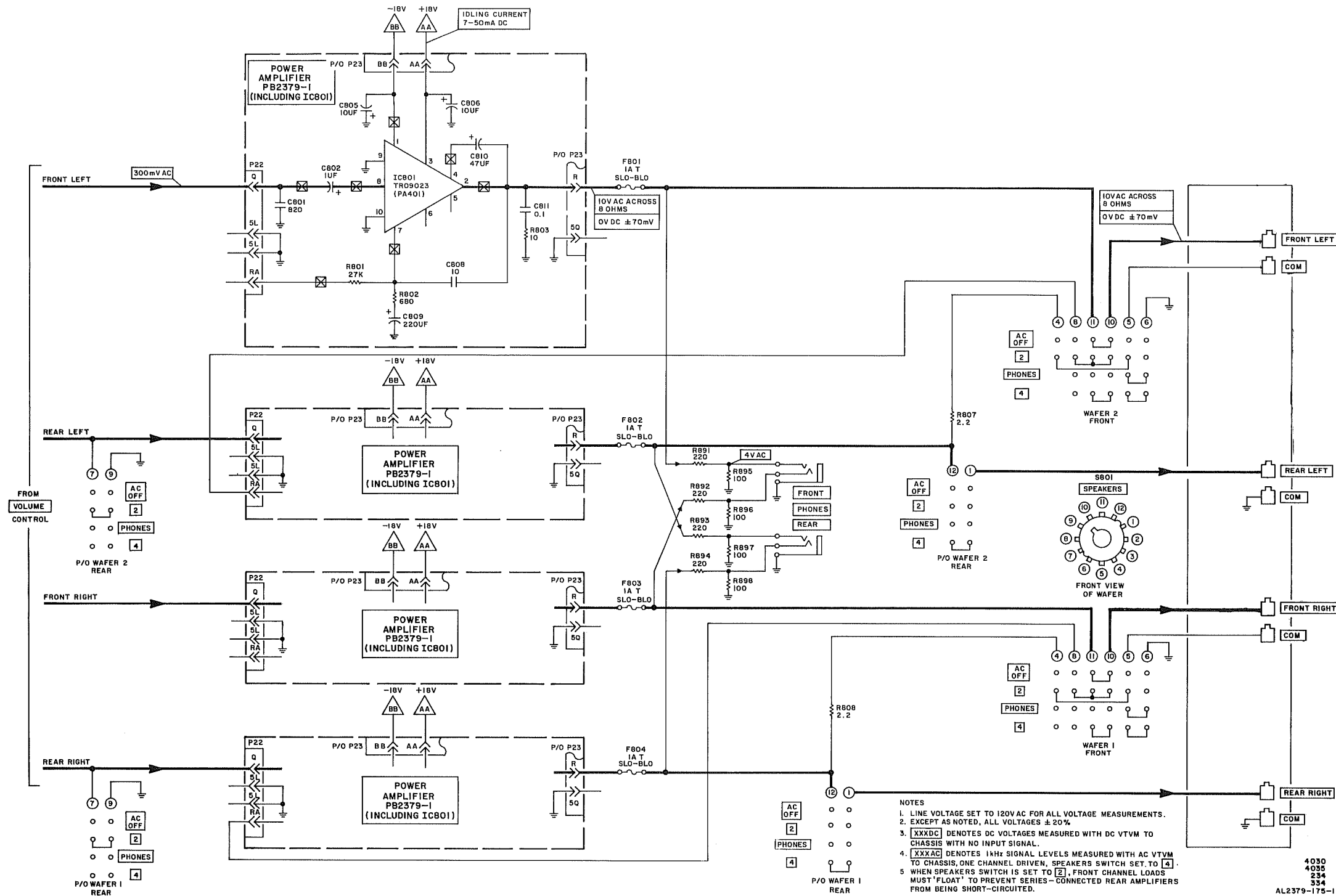

## POWER AMPLIFIER PARTS LIST

Ref. Des.	Description	Part Number
C801	Ceramic, 820 pF, 1%, 50V	CK22358-11
C802	Sintered Aluminum, 1 uF, 25V	CS22340-5
C805, 806	Electrolytic, 10 uF, 50V	CE22342-4
C808	Ceramic, 10 pF, 50V	CK22360-3
C809	Electrolytic, 220 uF, 25V	CE22342-14
C810	Electrolytic, 47 uF, 35V	CE22342-7
C811	Ceramic, 0.1 uF, ±35%, 100V	C51163
IC801	IC, Power Amplifier (18W/8 ohm)	TR09023
R801	27K	RF25DC273J
R802	680	RF25DC681J
R803	10, ½W	RF50DC100J

## CHASSIS MOUNTED COMPONENTS

Ref. Des.	Description	Part Number
F801, 802, 803, 804	Fuse, 1A, 250V, Slo-Blo	FL51313-3
R807, 808	Wirewound, 2.2, 15W	RP15W2R2J
R891, 892, 893, 894	Wirewound, 220, 2W	RW200W221J
R895, 896, 897, 898	100, ½W	RF50DC101J
S801	Switch, SPEAKERS	P/O SR4130-155
-	Jack, PHONES-FRONT, REAR	JK20627-5
-	Terminal Board, Speakers	ET51340-2

All Resistors are deposited film, 5%, ½W unless otherwise noted.  
K = Kiloohm

- NOTES
1. LINE VOLTAGE SET TO 120V AC FOR ALL VOLTAGE MEASUREMENTS. EXCEPT AS NOTED, ALL VOLTAGES ± 20%
  2. [XXXDC] DENOTES DC VOLTAGES MEASURED WITH DC VTVM TO CHASSIS WITH NO INPUT SIGNAL.
  3. [XXXAC] DENOTES 1kHz SIGNAL LEVELS MEASURED WITH AC VTVM TO CHASSIS, ONE CHANNEL DRIVEN, SPEAKERS SWITCH SET TO [4]. WHEN SPEAKERS SWITCH IS SET TO [2], FRONT CHANNEL LOADS MUST "FLOAT" TO PREVENT SERIES-CONNECTED REAR AMPLIFIERS FROM BEING SHORT-CIRCUITED.

4030  
4035  
234  
334  
AL2379-175-1

# POWER SUPPLY/DIAL LAMP SCHEMATIC

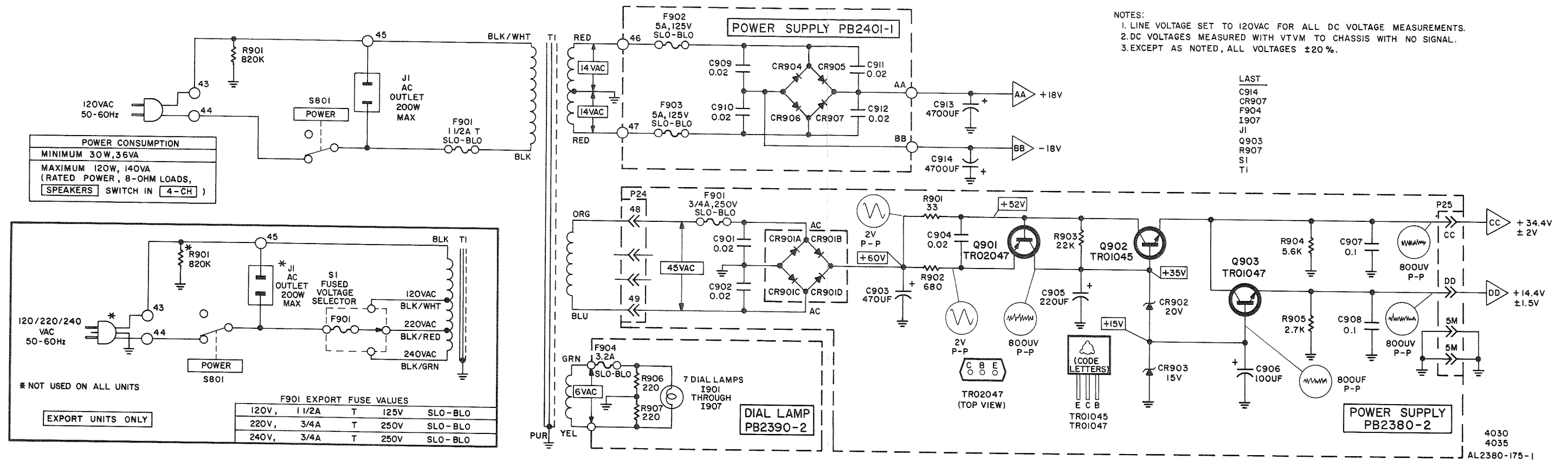

## POWER SUPPLY/DIAL LAMP PARTS LIST

2380-2

### CHASSIS MOUNTED COMPONENTS

Ref. Des.	Description	Part Number
C913, 914	Electrolytic, 4700 uF, 35V	CE22372-2
F901	Fuse, 1 1/2A, 125V, Slo-Blo	FL51313-20
*F901	Fuse, 3/4A, 250V, Slo-Blo	FL51313-7
J1	AC Outlet	JK25009
R901	Composition, 820K, 10%, 1/2W	RC20BF824K
*S1	Switch, Fused Voltage Selector	EA51449
T1	Transformer, Power	TD4130-115
*T1	Transformer, Power	TE4130-215
-	Fuse Holder	EA51408
-	Line Cord	W50023-1
-	Line Cord	*WR20678

Ref. Des.	Description	Part Number
C901, 902, 904	Ceramic, 0.02 uF, ±20%, 500V	CK22359-3
C903	Electrolytic, 470 uF, 100V	CE22343-44
C905	Electrolytic, 220 uF, 50V	CE22343-28
C906	Electrolytic, 100 uF, 25V	CE22343-26
C907, 908	Mylar, 0.1 uF, 10%, 100V	CY22373-1
CR901	Bridge Rectifier, 1.5A, 200V (A,B,C,D)	BR51400-1
CR902	Zener, 20V, 5%, 1W	TR14002-4
CR903	Zener, 15V, 5%, 1W	TR14002-2
F901	Fuse, 3/4A, 250V, Slo-Blo	FL51313-7
Q901	Transistor, PNP	TR02047
Q902	Transistor, NPN	TR01045
Q903	Transistor, NPN	TR01047
R901	Wirewound, 33, 5%, 5W	RW5W330J
R902	680	RF50DC681J
R903	22K	RF50DC223J
R904	5.6K	RF50DC562J
R905	27K	RF50DC272J

2401-1

Ref. Des.	Description	Part Number
C909, 910, 911, 912	Ceramic, 0.02 uF, ±20%, 500V	CK22359-3
CR904, 905, 906, 907	Diode, Silicon, 5A, 200V	SIB51169-2
F902, 903	Fuse, 5A, 125V, Slo-Blo	FL51313-10
<b>PB2390-1</b>		
F904	Fuse, 3.2A, 125V, Slo-Blo (Pigtail)	FL51313-14
I901 thru I907	Lamp (2112D), Dial	LM21421-6
R906, 907	Composition, 220, 10%, 1/2W	RC20BF221K

\*Used in Export Units All resistors are deposited carbon, 5%, 1/2W unless otherwise noted. K = Kilohm



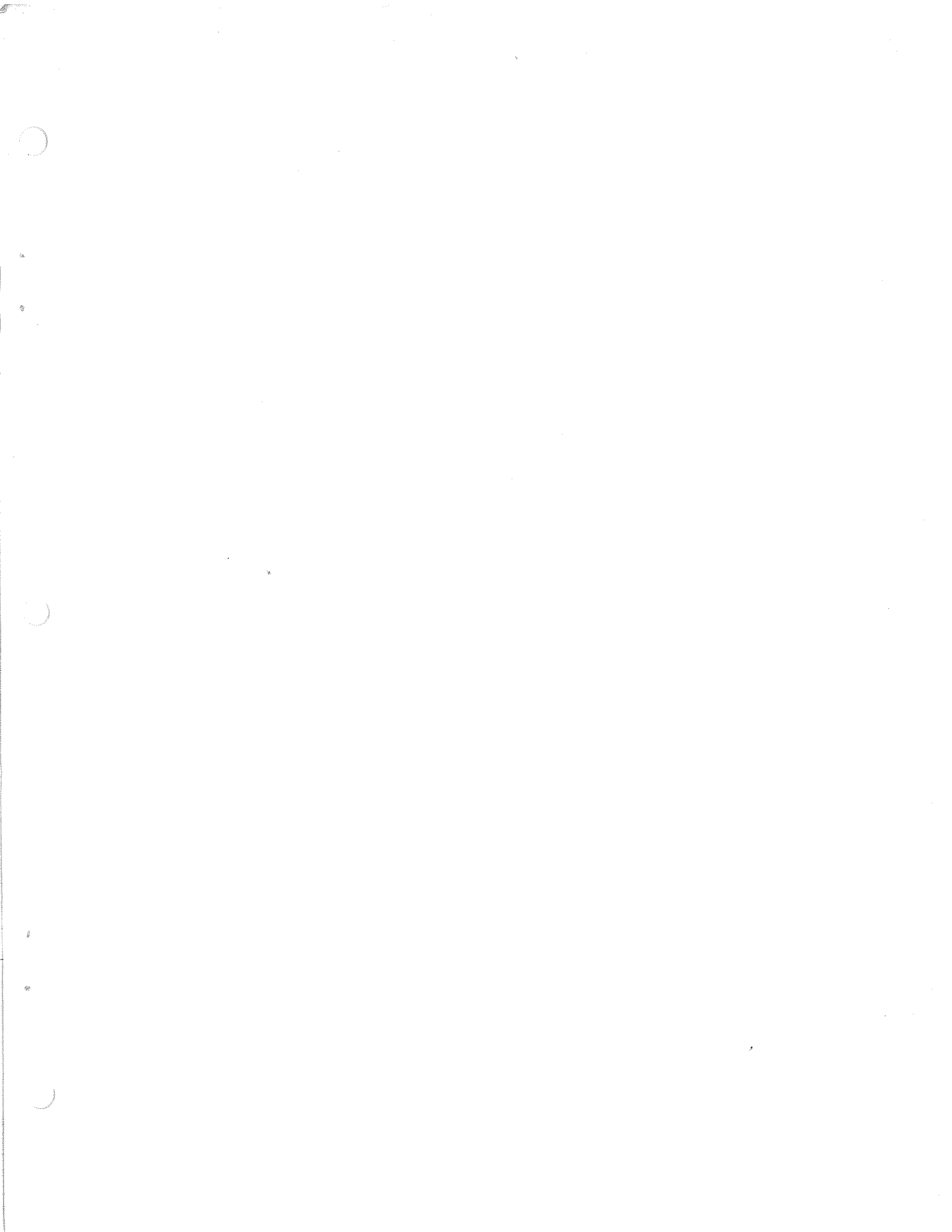

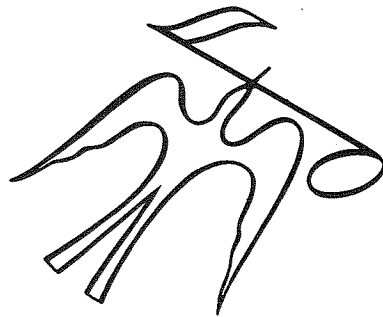

FISHER RADIO • 11-40 45th ROAD • LONG ISLAND CITY • NEW YORK 11101