

**SERVICE MANUAL**

# The Fisher®

# 432

**FM-AM**

**Stereo Receiver**

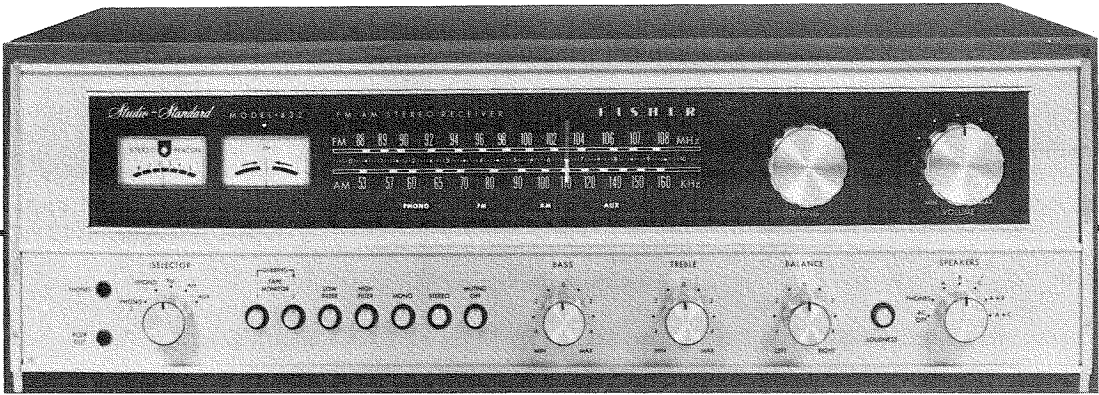

**WORLD LEADER IN HIGH QUALITY STEREO**

## REQUIRED TEST EQUIPMENT

The following test equipment is required to completely test and align the Receiver:

- Line Voltage Autotransformer or Voltage Regulator
- AC DC Multimeter
- Accurately Calibrated AC Voltmeter
- Oscilloscope (Flat to 100 kHz Minimum)
- Low-Distortion Audio Sine-Wave Generator
- Harmonic Distortion Analyzer
- Two (2) Load Resistors, 8-ohms, 250 Watts (Minimum Rating)
- Low-Distortion AM-FM Signal Generator
- 10.7 MHz Sweep Generator
- Multiplex Generator
- 455 kHz Sweep Generator

## HARMONIC DISTORTION TEST

**CAUTION:** Limit the following tests to no more than ten minutes each. Use 8-ohm resistors with a minimum power rating of 250 watts when connecting a load across the SPEAKERS terminals.

### CONTROL SETTINGS:

Unplug the AC power cord and set the front panel controls as follows:

BASS, TREBLE, and BALANCE controls to center positions

SPEAKERS switch to AC OFF

SELECTOR switch to AUX

STEREO pushbutton depressed

LOUDNESS pushbutton out (not depressed)

VOLUME control to MIN

### ONE CHANNEL DRIVEN:

(1) Connect a low distortion audio generator to LEFT AUX IN jack. Set generator frequency to 1 kHz and output to minimum.

(2) Connect an 8-ohm load resistor between SPEAKERS A LEFT and COM terminals. Connect a Harmonic Distortion analyzer and an AC VTVM in parallel across the 8-ohm load.

(3) Connect the AC power cord and set SPEAKERS switch to A. Turn VOLUME control to MAX.

(4) Increase generator output for 40 Watts RMS (17.9 V across the 8-ohm load). Harmonic Distortion Analyzer should measure 0.5% distortion or less.

(5) Repeat steps 1 through 4 for RIGHT CHANNEL.

### BOTH CHANNELS DRIVEN

Connect 8-ohm load resistors across LEFT and RIGHT MAIN SPEAKERS terminals. Depress "MONO" pushbutton. Adjust generator output and "BALANCE" control for 40 Watts at Left and Right Channels (17.9 Volts across the 8-ohm loads). Harmonic Distortion Analyzer should measure 0.5% distortion or less at each channel.

### CAUTION:

This precision high-fidelity instrument should be serviced only by qualified personnel, trained in the repair of transistor equipment and printed circuitry.

# MULTIPLEX DECODER SCHEMATIC

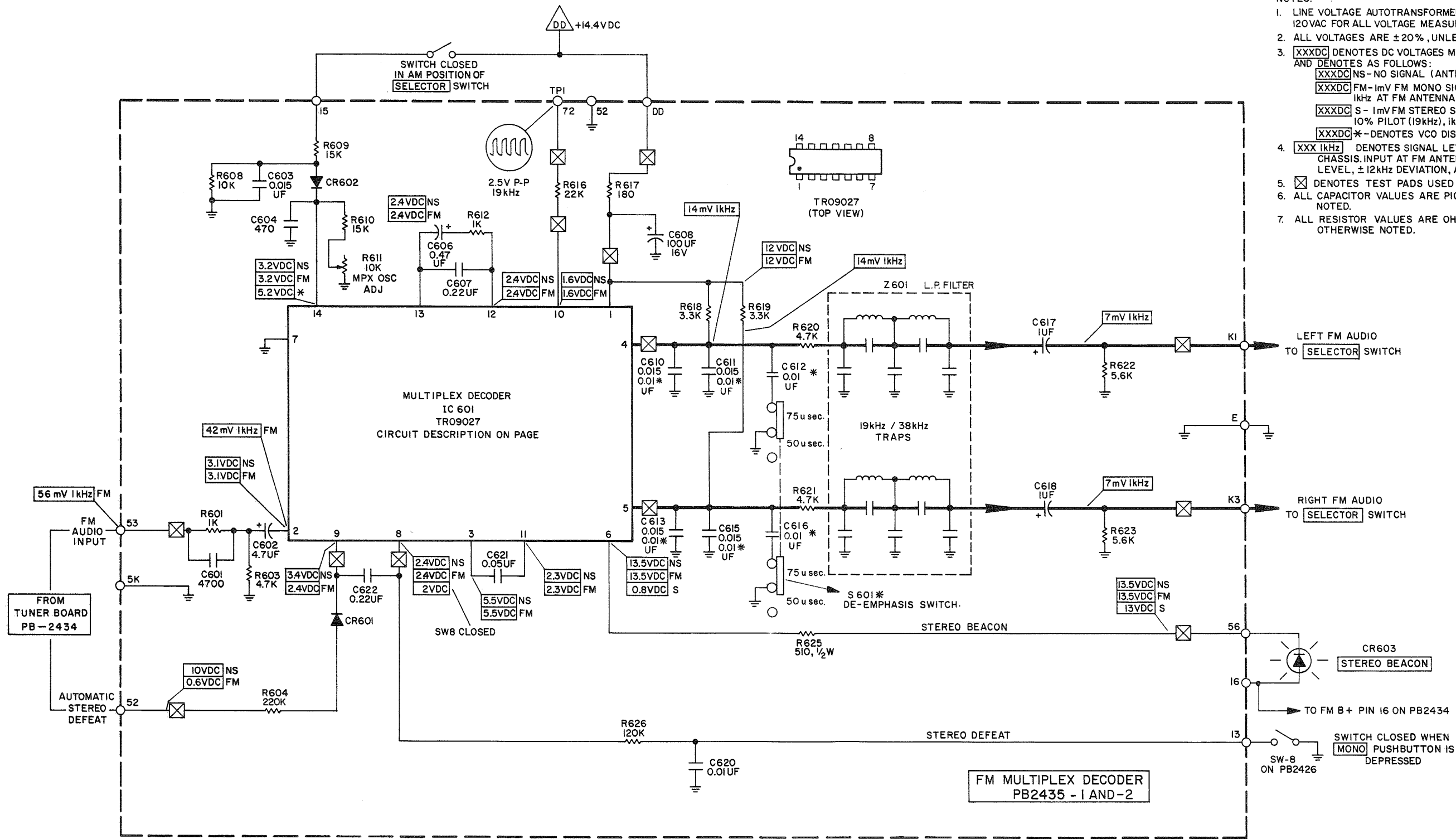

- NOTES:
1. LINE VOLTAGE AUTOTRANSFORMER OR VOLTAGE REGULATOR SET TO 120VAC FOR ALL VOLTAGE MEASUREMENTS.
  2. ALL VOLTAGES ARE  $\pm 20\%$ , UNLESS OTHERWISE NOTED.
  3. [XXXDC] DENOTES DC VOLTAGES MEASURED WITH DC VTVM TO CHASSIS, AND DENOTES AS FOLLOWS:  
 [XXXDC] NS - NO SIGNAL (ANTENNA TERMINALS SHORTED).  
 [XXXDC] FM - 1mV FM MONO SIGNAL AT 98MHz,  $\pm 75$ kHz DEVIATION, 1kHz AT FM ANTENNA.  
 [XXXDC] S - 1mV FM STEREO SIGNAL AT 98MHz,  $\pm 75$ kHz DEVIATION, 10% PILOT (19kHz), 1kHz LEFT CHANNEL, AT FM ANTENNA.  
 [XXXDC] \* - DENOTES VCO DISABLING VOLTAGE IN AM OPERATION.
  4. [XXX kHz] DENOTES SIGNAL LEVELS MEASURED WITH AC VTVM TO CHASSIS. INPUT AT FM ANTENNA TERMINALS: 98 MHz, 1mV LEVEL,  $\pm 12$ kHz DEVIATION, AT 1kHz.
  5.  $\otimes$  DENOTES TEST PADS USED FOR PRODUCTION TESTING.
  6. ALL CAPACITOR VALUES ARE PICO FARAD UNLESS OTHERWISE NOTED.
  7. ALL RESISTOR VALUES ARE OHMS,  $\pm 5\%$ ,  $\frac{1}{4}$  WATT UNLESS OTHERWISE NOTED.

OPEN	LAST
R602,605,606,607	R 626
R614,615,624,613	C 622
C605,609,614	CR 603
C619	

## MULTIPLEX DECODER IC SIGNAL FLOW

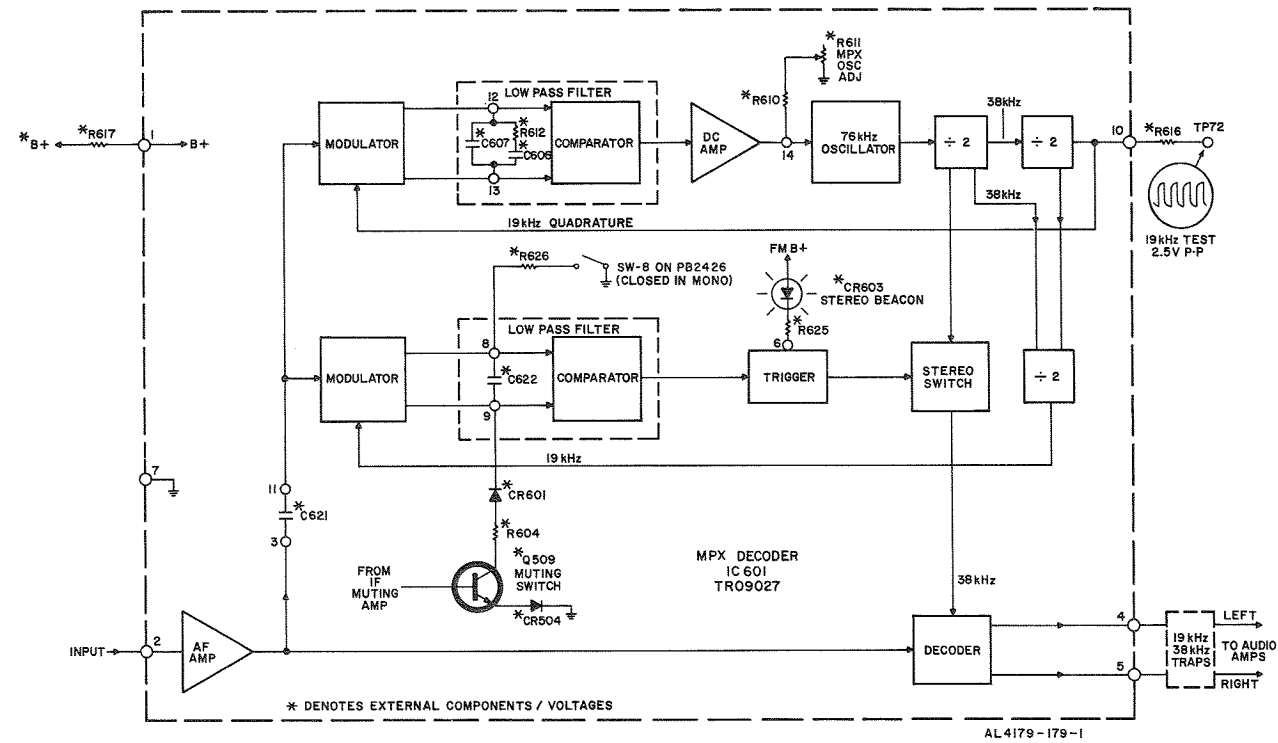

## MULTIPLEX DECODER IC DESCRIPTION

### MPX IC

When the receiver is tuned to a stereo broadcast the composite audio fed to pin 2 consists of sum-and-difference signal information (L+R and L-R), and a 19 kHz pilot tone. The L+R information is in the form of normal audio. The L-R information is Amplitude Modulated on a suppressed 38 kHz subcarrier. (At the transmitter, the subcarrier is derived from the pilot tone through a frequency-doubler). In order to extract the L-R information, it is necessary to regenerate the 38 kHz subcarrier and apply it, together with the composite signal, to the decoder. Left and Right channel information is then decoded by addition and subtraction of the L+R and L-R information.

The top line of the block diagram shows the 38 kHz subcarrier regeneration loop. The 76 kHz oscillator output is processed through two frequency divider stages to furnish 38 kHz and 19 kHz outputs. The 19 kHz output is a quadrature (90° out-of-phase) signal which is applied to the modulator. When the composite input signal contains a 19 kHz pilot tone (stereo broadcast) the 19 kHz quadrature signal is phase-compared to the pilot signal and the resulting DC voltage fed through the DC amp to the oscillator, where

it corrects the frequency. As a result, the oscillator is continuously phase-locked to the pilot signal. The setting of R611 determines the frequency of the free-running oscillator. With the oscillator phase-locked to the pilot, the 38 kHz output from the first divider is in the correct phase for decoding a stereo signal. The regenerated 38 kHz signal is fed to the decoder via a stereo switch. The stereo switch closes when a sufficiently large 19 kHz pilot tone is detected in the second modulator-comparator circuit. A third frequency divider stage, which processes signals derived from the first two dividers, returns a 19 kHz in-phase signal to the second modulator-comparator for pilot-detection. The DC voltage derived from the second modulator-comparator circuit is applied to the trigger which activates the STEREO-BEACON indicator and the stereo switch.

The circuit is forced into the monophonic mode by grounding pin 8, or by applying a positive DC voltage to pin 9. With very low-level, noisy FM signals, a positive voltage from pin 12 of IC501 is amplified without change of polarity and applied to pin 9 of IC601 forcing the circuit into mono operation. During AM operation pin 14 bias is high thus disabling the 76 kHz oscillator and eliminating interference.

## FM IF IC SIGNAL FLOW

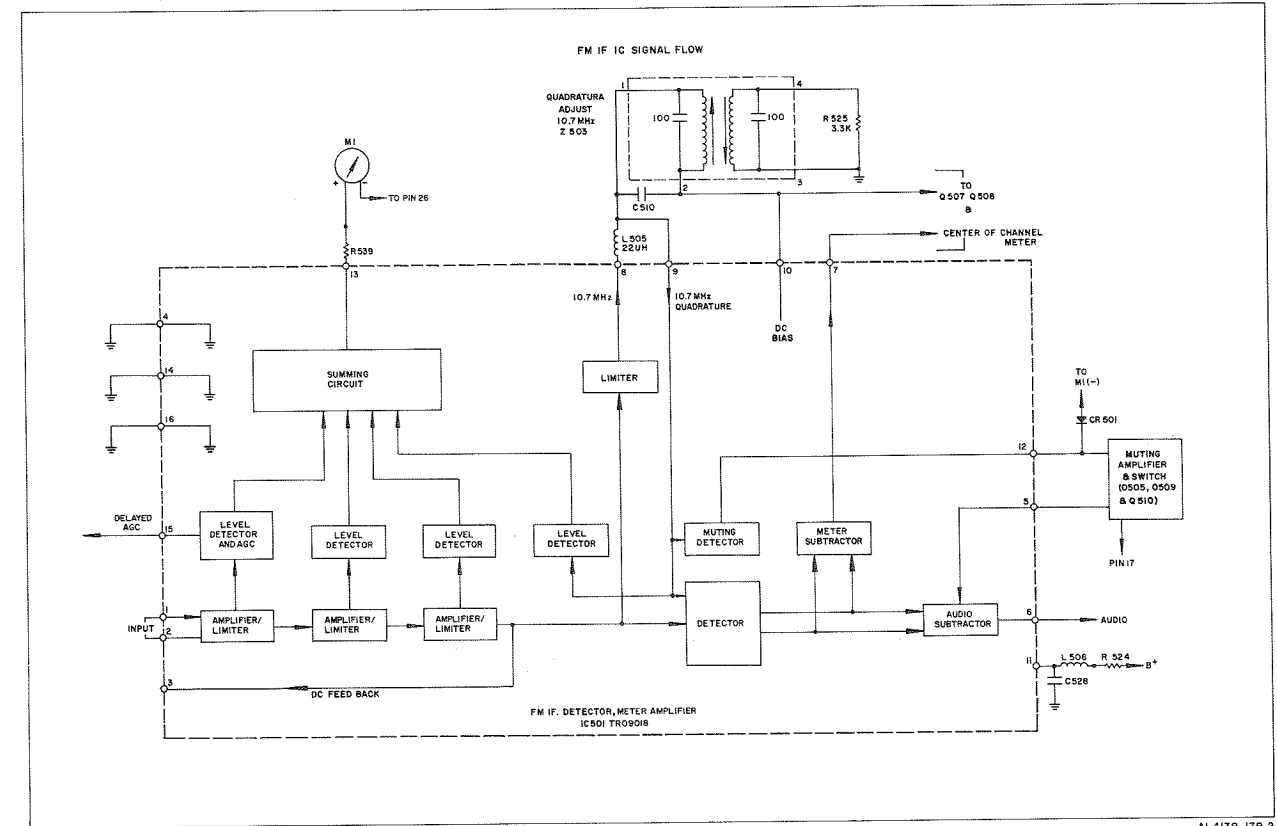

## FM IF IC DESCRIPTION

### FM IF DETECTOR AND METER AMPLIFIER INTEGRATED CIRCUIT.

The input from the IF filter is processed through three stages of amplification and limiting. The output of the third limiter is applied to a fourth limiter, and a balanced detector. The push-pull output from the detector is combined differentially in the subtractor stage to produce an audio output at pin 6.

The output from the fourth limiter is applied through L505 to a tuned circuit Z503. At the exact center of the IF passband (nominally 10.7 MHz), Z503 is preset to provide a 10.7 MHz quadrature (90 degrees out-of-phase) signal to the detector. The phase of the signal from the tuned circuit changes proportionally with changes in the frequency of the IF signal. With no audio modulation, the inputs of the detector are in quadrature and the outputs of the detector are in quadrature and the outputs of the detector are balanced. No differential signals appear at the outputs of the subtractor stages. When the frequency of the IF signal deviates from

10.7 MHz ( as a result of audio modulation or station detuning), the detector outputs are unbalanced and a differential DC signal appears at pin 6.

The muting detector (pin 12) monitors the envelope signal-to-noise ratio across the tuned circuit and feeds the detected noise to the muting amplifier and switch. Excessive noise in the signal generates a control voltage which is amplified and applied to pin 9 of IC601 to force the receiver into monophonic operation and to pin 5 of IC 501 for muting.

Level detectors (pin 13) monitor the IF signal levels at the three amplifier/limiter stages and at the tuned circuit. Each limiter, beginning with the last, saturates progressively as the input level increases. Rectified signals from the level detectors are summed and applied (pin 13) as a linear-log voltage to the Field Strength meter.

As AGC voltage (pin 15) for the RF amplifier is obtained from the first level detector. This AGC voltage is delayed until the IF signal in the first amplifier approaches limiting.

# POWER AMPLIFIER SCHEMATIC

- NOTES:  
 1. LINE VOLTAGE AUTOTRANSFORMER OR VOLTAGE REGULATOR SET TO 120VAC FOR ALL VOLTAGE MEASUREMENTS.  
 2. ALL VOLTAGES ARE ±20% UNLESS OTHERWISE NOTED.  
 3. [XXXDC] DENOTES DC VOLTAGES MEASURED WITH DC VTVM TO CHASSIS WITH NO INPUT SIGNAL.  
 4. [XXXkHz] DENOTES kHz SIGNAL LEVELS MEASURED WITH AC VTVM TO CHASSIS WITH 8Ω SPEAKER LOAD.  
 5. ALL CAPACITOR VALUES ARE PICO FARAD UNLESS OTHERWISE NOTED.  
 6. ALL RESISTOR VALUES ARE OHMS, ±5%, 1/4WATT UNLESS OTHERWISE NOTED.

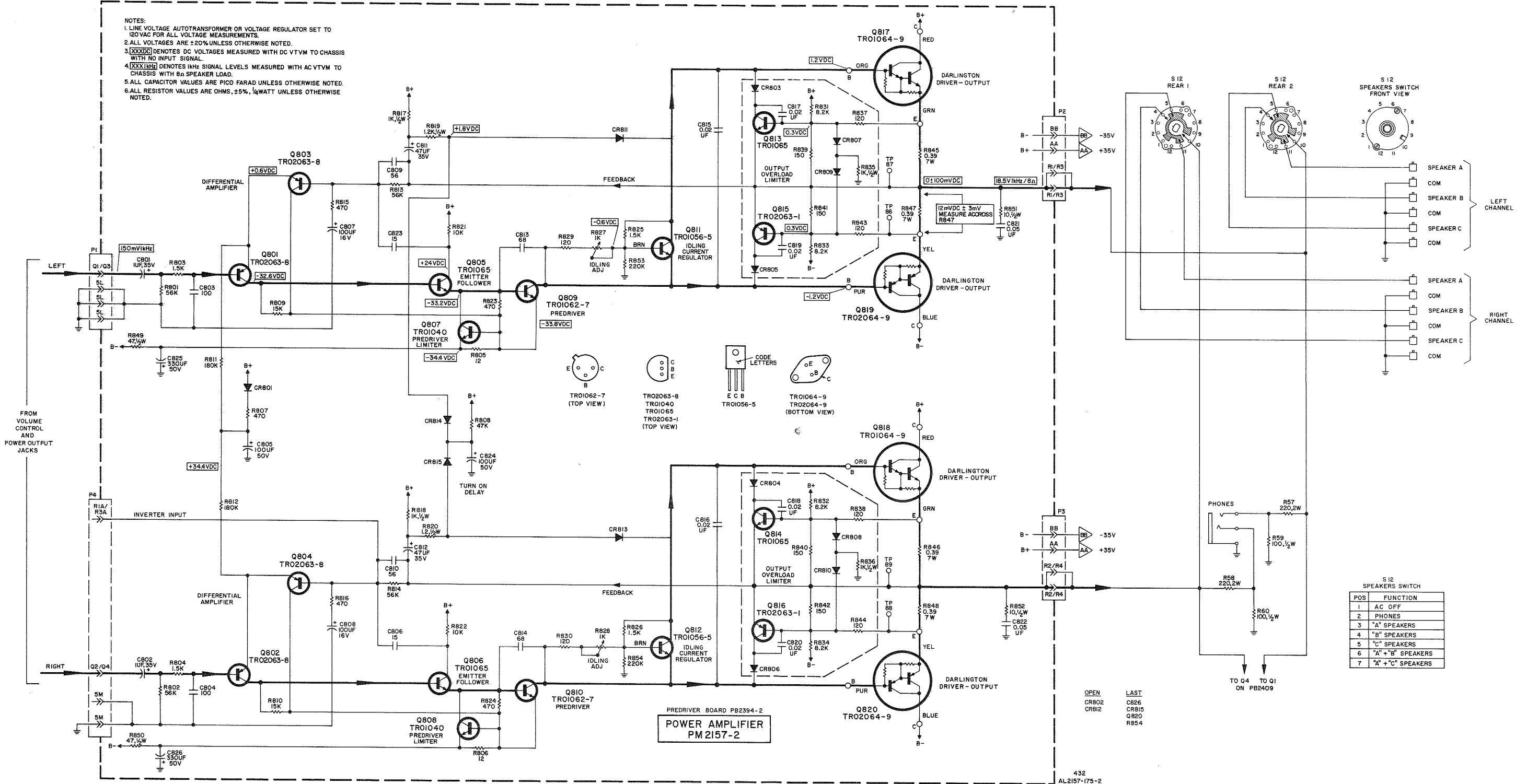

S 12 SPEAKERS SWITCH

POS	FUNCTION
1	AC OFF
2	PHONES
3	"A" SPEAKERS
4	"B" SPEAKERS
5	"C" SPEAKERS
6	"A" + "B" SPEAKERS
7	"A" + "C" SPEAKERS

# POWER SUPPLY AND SPEAKER PROTECTION SCHEMATIC

POWER CONSUMPTION	
MINIMUM	MAXIMUM
17W 55 VA	250W 300VA MAX.
	RATED POWER 4 OHM LOAD

- NOTES:
1. LINE VOLTAGE AUTOTransFORMER OR VOLTAGE REGULATOR SET TO 120VAC FOR ALL VOLTAGE MEASUREMENTS.
  2. ALL VOLTAGES ARE  $\pm 20\%$ , UNLESS OTHERWISE NOTED. **XXXDC** DENOTES DC VOLTAGES MEASURED WITH DC VTVM TO CHASSIS.
  3. ALL CAPACITOR VALUES ARE PICO FARAD UNLESS OTHERWISE NOTED.
  4. ALL RESISTOR VALUES ARE OHMS,  $\pm 5\%$ ,  $\frac{1}{4}$  WATT UNLESS OTHERWISE NOTED.

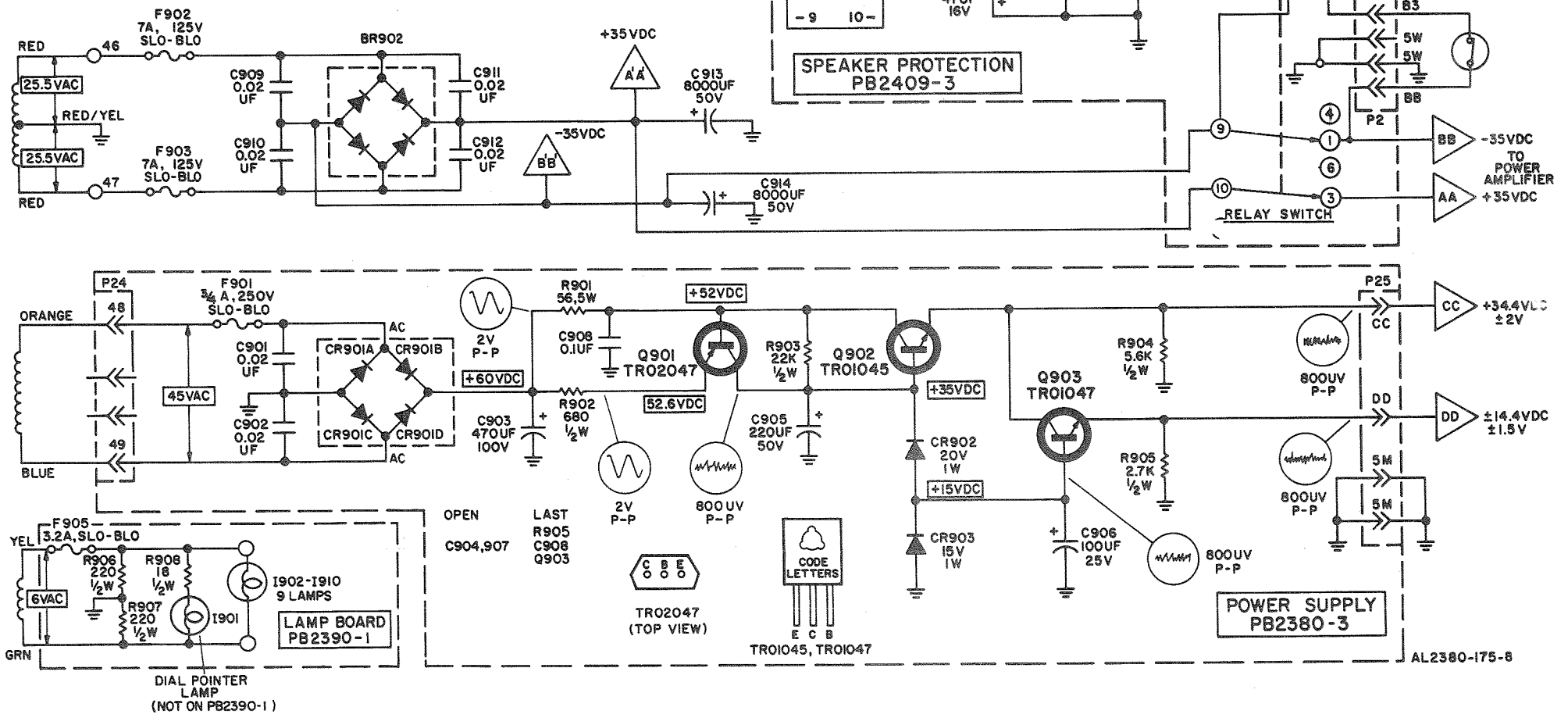
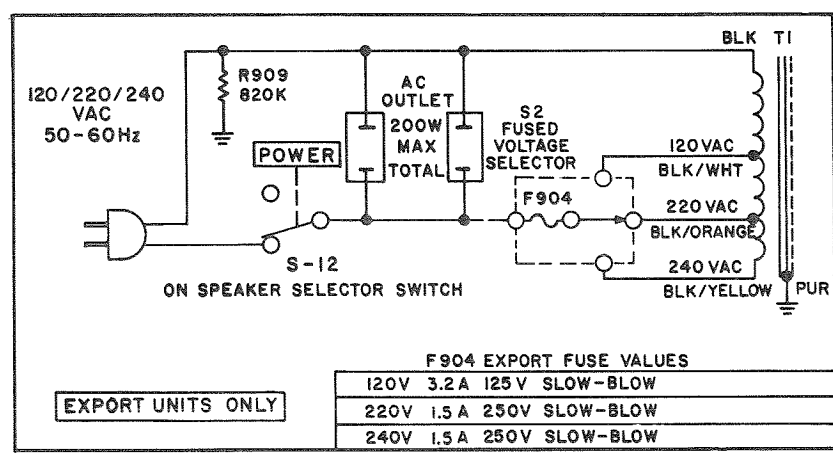
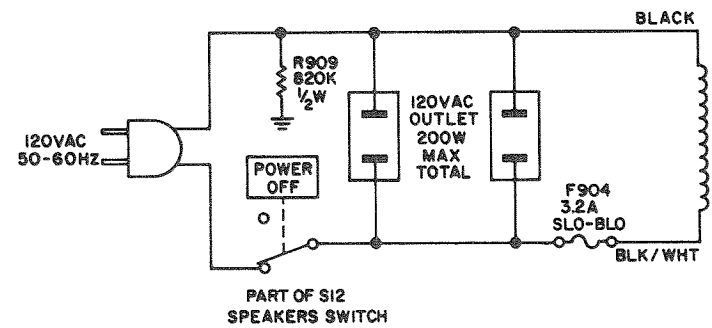

# PARTS LIST

## CHASSIS

Symbol No.	Part Number	Description
	AB51465	Bracket, Antenna Support
	AS51470	Drive Wheel Assy.
	AS20747	Tuning Shaft Assembly
	EA51408	Fuse Holder
	ET25028-6	Terminal Board, Speakers
	ET51459	Antenna Terminal Strip
	JK20627-5	Jack, Earphone
	JK25009	AC Outlet
	JK25022	15 Jack Connector
	JK25024	4 Jack Connector
	EA51464	Clamp, Antenna
S12	SR4180-128	Speaker Switch
S11	SR4180-133	Selector Switch
T1	TD4180-115	Power Transformer, 110 V
T1	**TE4180-215	Power Transformer, Multivoltage
	**TE4180-215	Power Transformer, Multivoltage
	LA51417-4	AM Antenna
	**EA51449	Multiple Voltage Selector
	LA51417-4	AM Antenna

## CABINET

Symbol No.	Part Number	Description
	AS4180-121	Cabinet Assembly
	E51172	Plastic Foot
	EA51406	Grill

## MISCELLANEOUS

Symbol No.	Part Number	Description
	AS4180-105	Dress Panel Assembly
	AD23120-3	Dress Panel Extrusion
	AD23126-5	End Strip (Left)
	AD23126-6	End Strip (Right)
	AD23130-2	Insert, Upper
	AD23122-2	Insert, Lower Screened
	AD23124	Window
	AS4180-109-1	Dial Plate
	AM20510	Carriage, Pointer
	AM20511	Housing, Pointer
	AP20508-3	Pointer (Plastic)
I901	LM21442-1	Lamp, Pointer

## MISCELLANEOUS

Symbol No.	Part Number	Description
M1	MC21627-1	Meter (Signal Strength)
M2	MC21628-1	Meter (Center of Channel)
CR603	TR19001	Light Emitting Diode
	AS25026	Jumper
BR902	BR51401-3	Bridge Rectifier 200V 10A
C27	CE22343-28	Capacitor, Electrolytic 220uF 50V
C913, 914	CE22374-2	Capacitor, Electrolytic 8000uF 50V
C47, 48, 49, 50, 51	CK22355-4	Capacitor, Ceramic 0.001uF
C25, 26	CK22358-8	Capacitor, Ceramic 470pF
C909, 910	CK22359-3	Capacitor, Ceramic 0.02uF
911, 912		
F904	FL51313-6	Fuse 3.2A 125V Slo-Blo
F904	**FL51313-18	Fuse 1.5A 250V Slo-Blo
F902, 903	FL51313-9	Fuse 7A 125V Slo-Blo
R50, 52	RF25DC102J	Resistor 1K ohm ¼W
R23, 24	RF25DC104J	Resistor 100K ohm ¼W
R19, 20, 21, 22	RF25DC152J	Resistor 1.5K ohm ¼W
R25, 26	RF25DC562J	Resistor 5.6K ohm ¼W
R909	RC20BF824K	Resistor 920K ohm ½W
R59, 60	RF50DC101J	Resistor 100 ohm ½W
R29	RF50DC222J	Resistor 2.2K ohm ½W
R57, 58	RP2W221J	Resistor 220 ohm 2W
R49	RP3W271J	Resistor 270 ohm 3W
R55	RP50160-326	Volume Control
	PB2303-2	Pre Amp
	PB2380-3	PCB Regulated Power Supply
	PB2390-1	PCB Dial Lamp
	PB2395-4	PCB Lamp Assy.
	PB2394-1	PCB, Pre Driver
	PM2157-2	Power Amplifier Module
	PB2409-3	Speaker Protection Board
	PB2426-1	PCB Tone Control and Mode Selector
	PB2434-1	PCB Tuner
	**PB2435-2	PCB MPX Decoder
	EK20046-4	Knob, Pushbutton
	EK20062-3	Knob, Volume Control
	EK20062-1	Knob, Tuning
	EK20063-1	Knob, Bass/Treble/Balance/Switch

\*\*Export Versions Only

# PARTS LIST

## Preamplifier PCB PB2303-2

<u>Symbol No.</u>	<u>Part Number</u>	<u>Description</u>
C33	CE22342-16	Capacitor, Electrolytic 220 uF 10V
C41, 42	CK22344-1	Capacitor, Ceramic 5pF
C39, 40	CK22349-2	Capacitor, Ceramic 0.005uF
C37, 38	CK22350-1	Capacitor, Ceramic 120pF
C43, 44	CK22351-8	Capacitor, Ceramic 0.0015uF
C29, 30	CK22360-8	Capacitor, Ceramic 33pF
C35, 36	CL22305-12	Capacitor, Tantalum, 10uF 10V
C45, 46	CL22305-4	Capacitor, Tantalum 2.7uF 35V
C31, 32	CL22306-2	Capacitor, Tantalum 0.68uF 35V
R35, 47, 48	RF25DC103J	Resistor 10K ohm, ¼W
R36	RF25DC104J	Resistor 100K ohm, ¼W
R41, 42	RF25DC105J	Resistor 1M ohm, ¼W
R33, 34	RF25DC124J	Resistor 120K ohm, ¼W
R43, 44	RF25DC183J	Resistor 18K ohm, ¼W
R45, 46	RF25DC563J	Resistor 56K ohm, ¼W
R39, 40	RF25DC821J	Resistor 820 ohm, ¼W
R31, 32, 37, 38	RF25DC823J	Resistor 82K ohm, ¼W
Q33, 34	TR01015	Transistor NPN
Q31, 32	TR02020-2	Transistor PNP 2N4250

## Power Supply PCB PB2380-3

<u>Symbol No.</u>	<u>Part Number</u>	<u>Description</u>
CR901	BR51400-1	Bridge Rectifier 1.5A 200V
C906	CE22343-26	Capacitor, Electrolytic 100uF 25V
C905	CE22343-28	Capacitor, Electrolytic 220uF 50V
C903	CE22343-44	Capacitor, Electrolytic 470uF 100V
C901, 902	CK22359-3	Capacitor, Ceramic 0.02uF
C908	CY22373-1	Capacitor, Mylar 0.1uF
F901	FL51313-7	Fuse ¼A 250V Slo-Blo
R903	RF50DC223J	Resistor 22K ohm ½W
R905	RF50DC272J	Resistor 2.7K ohm ½W
R904	RF50DC562J	Resistor 5.6K ohm ½W
R902	RF50DC681J	Resistor 680 ohm ½W
R901	RW5W560J	Resistor 56 ohm 5W
Q902	TR01045	Transistor NPN
Q903	TR01047	Transistor NPN
Q901	TR02047	Transistor PNP
CR903	TR14002-2	Zener Reg 15V 1W
CR902	TR14002-4	Zener Reg 20V 1W

## Dial Lamp PCB PB2390-1

<u>Symbol No.</u>	<u>Part Number</u>	<u>Description</u>
F905	FL51313-14	Fuse 3.2A 125V Slo-Blo Pig Tail
I902-910	LM21421-6	Lamp 2112D (GE only)
R908	RC20BF180K	Resistor 18 ohm ½W
R906, 907	RC20BF221K	Resistor 220 ohm ½W

## TONE & MODE PCB PB2426-1

<u>Symbol No.</u>	<u>Part Number</u>	<u>Description</u>
C109, 110, 119, 120, 123, 124	CE22342-2	Capacitor, Electrolytic 1uF 50V
C105	CE22343-33	Capacitor, Electrolytic 470uF 50V
C121, 122	CK22344-16	Capacitor, Ceramic 21pF
C125, 126	CK22347-11	Capacitor, Ceramic 820pF
C107, 108	CL22305-2	Capacitor, Tantalum 0.68uF 35V
C101, 102	CY22335-13	Capacitor, Mylar 0.027uF
C127, 128	CY22335-20	Capacitor, Mylar 0.22uF
C115, 116	CY22335-23	Capacitor, Mylar 0.0012uF
C103, 104, 111, 112, 113, 114	CY22335-2	Capacitor, Mylar 0.015uF
R133, 134	RC07BF155J	Resistor 1.5M ohm ¼W
R109, 110	RC07BF222J	Resistor 2.2K ohm ¼W
R103, 104, 117, 118	RF25DC102J	Resistor 1K ohm ¼W
R129, 130	RF25DC103J	Resistor 10K ohm ¼W
R101, 102, 107, 108	RF25DC105J	Resistor 1Mohm ¼W
R143, 144	RF25DC152J	Resistor 1.5K ohm ¼W
R115, 116	RF25DC182J	Resistor 1.8K ohm ¼W
R121, 122, 125, 126, 127, 128	RF25DC223J	Resistor 22K ohm ¼W
R113, 114	RF25DC274J	Resistor 270K ohm ¼W
R135, 136	RF25DC392J	Resistor 3.9K ohm ¼W
R105, 106, 139, 140	RF25DC472J	Resistor 4.7K ohm ¼W
R111, 112	RF25DC823J	Resistor 82K ohm ¼W
R141	RP50160-327	Balance Control 250K ohm
R123, 131	RP50160-328	Bass/Treble Control 200K ohm
SW8	SP50200-77	Switch, 1 pushbutton
SW1-7	SP50200-85-1	Switch, 7 pushbuttons
Q101, 102, 103, 104	TR01015	Transistor NPN
R137	RC20BF271J	Resistor 270 ohm ½W

## Speaker Protec. PCB PB2409-3

<u>Symbol No.</u>	<u>Part Number</u>	<u>Description</u>
C950, 951, 952, 953	CE22342-8	Capacitor, Electrolytic 47uF 16V
R953, 950	R50DC102J	Resistor 1K ohm ½W
R956, 959, 960	RF25DC123J	Resistor 12K ohm ¼W
R957, 958, 962	RF25DC223J	Resistor 22K ohm ¼W
R954, 955	RF25DC224J	Resistor 220K ohm ¼W
R963	RP2W221J	Resistor 220 ohm 2W
K950	SK51490	Relay KA11DG, 25VDC
Q953	TR01048	Transistor NPN
Q951	TR02063-1	Transistor SPS 945 MK
Q950	TR02063-8	Transistor



# PARTS LIST

## POWER AMPLIFIER MODULE PM2157-2

Symbol No.	Part Number	Description
	PB2394-1	
C801, 802	CL22305-3	Capacitor, Tantalum 1uF, 35V
C803, 804	CK22351-1	Capacitor, Ceramic 100pF
C805, 824	CE22342-9	Capacitor, Electrolytic 100uF, 50V
C806, 823	CK22344-9	Capacitor, Ceramic 15pF
C807, 808	CE22342-12	Capacitor, Electrolytic 100uF, 16V
C809, 810	CK22360-16	Capacitor, Ceramic 56pF
C811, 812	CE22342-7	Capacitor, Electrolytic 47uF, 35V
C813, 814	CK22344-26	Capacitor, Ceramic 68pF
C815, 816, 817, 818, 819, 820	CK22354-2	Capacitor, Ceramic 0.02uF, 50V
C821, 822	CK22362-14	Capacitor, Ceramic 0.05uF
C825, 826	CE22342-27	Capacitor, Electrolytic 330uF, 50V
CR801, 803, 804, 805, 806, 807, 808, 809, 810, 813, 814, 815, 816	TR13006-3	Silicon Diode
R801, 802, 813, 814	RF25DC563J	Resistor, 56K ohm 1/4W
R803, 804, 825, 826	RF25DC152J	Resistor, 15K ohm 1/4W
R805, 806	RF25DC120J	Resistor, 12 ohm 1/4W
R807, 815, 816, 823, 824	RF25DC471J	Resistor, 470 ohm 1/4W
R808	RF25DC473J	Resistor, 47K ohm 1/4W
R809, 810	RF25DC153J	Resistor, 150 ohm 1/4W
R811, 812	RF25DC184J	Resistor, 180K ohm 1/4W
R817, 818, 835, 836	RF50DC102J	Resistor, 1K ohm 1/4W
R919, 920	RC20BF122J	Resistor, 1.2K ohm 1/4W
R821, 822	RF25DC103J	Resistor, 10K ohm 1/4W
R827, 828	R50150-20-2	Resistor, Variable 1K
R831, 832, 833, 834	RF25DC822J	Resistor, 8.2K ohm 1/4W
R837, 838, 843, 844	RF25DC121J	Resistor, 120 ohm 1/4W
R839, 840, 841, 842	RF25DC151J	Resistor, 150 ohm 1/4W
R845, 846, 847, 848	RF7WR39J	Resistor, 0.39 ohm 7W
R849, 850	RF50DC470J	Resistor, 47K ohm 1/2W
R851, 852	RC20BF100K	Resistor, 10 ohm 1/2W
R853, 854	RF25DC224J	Resistor, 220K ohm 1/4W
Q801, 802, 803, 804	TR02063-8	Transistor, PNP
Q805, 806, 813, 814	TR01065	Transistor, NPN
Q807, 808	TR01040	Transistor, NPN
Q809, 810	TR01062-7	Transistor, NPN
Q811, 812	TR01056-5	Transistor, NPN
Q817, 818	TR01064-9	Transistor, Darlington Driver, Output, NPN
Q819, 820	TR02064-9	Transistor, Darlington Driver, Output, PNP
S901	SM51486	Circuit Breaker, Thermal 105° C.

## MPX Decoder PCB PB2435-1 & 2\*

Symbol No.	Part Number	Description
C604	CA22313-1	Capacitor, Mica 470pF
C608	CE22342-12	Capacitor, Electrolytic 100uF 16V
C617, 618	CE22342-2	Capacitor, Electrolytic 1uF 50V
C602	CE22342-3	Capacitor, Electrolytic 4.7uF 50V
C601	CK22347-22	Capacitor, Ceramic 4700pF
C620	CK22354-1	Capacitor, Ceramic 0.01uF
C606	CS22340-4	Capacitor, Sintered Alum. 0.47uF 25V
C607, 622	CY22335-20	Capacitor, Mylar 0.22uF
C603, 610, 611, 613, 615	CY22335-2	Capacitor, Mylar 0.015uF
C621	CY22335-5	Capacitor, Mylar 0.05uF
R625	RC20BF511J	Resistor, 510 ohm 1/4W
R601, 612	RF25DC102J	Resistor, 1K ohm 1/4W
R608	RF25DC103J	Resistor, 10K ohm 1/4W
R626	RF25DC124J	Resistor, 120K ohm 1/4W
R609, 610	RF25DC153J	Resistor, 15K ohm 1/4W
R617	RF25DC181J	Resistor, 180 ohm 1/4W
R616	RF25DC223J	Resistor, 22K ohm 1/4W
R604	RF25DC224J	Resistor, 220K ohm 1/4W
R622, 623	RF25DC562J	Resistor, 5.6K ohm 1/4W
R618, 619	RF25DC332J	Resistor, 3.3K ohm 1/4W
R603, 620, 621	RF25DC472J	Resistor, 4.7K ohm 1/4W
R611	RV50150-23-7	Resistor, Variable 10K ohm
IC601	TR09027	Integrated Circuit, Multiplex
CR601, 602	TR13006-2	Diode, Silicon
Z601	ZZ50210-190	Filter, 15kHz Dual
S601	SS50200-30	Slide Switch **

\*Multiplex Decoder PB2435-2 is used in Export Receivers with multivoltage Power Transformers.

\*\* - 2 ONLY

## PCB LAMP ASSY. PB2395-4

Symbol No.	Part Number	Description
111, 12, 13	LM21421-7	Lamp 2187D (GE only)

# PARTS LIST

Tuner PCB PB2434-1

Tuner PCB PB2434-1

Symbol No.	Part Number	Description	Symbol No.	Part Number	Description
C518	C50938-5	Capacitor, Trimmer 1-6pF	R510	RF25DC121J	Resistor 120 ohm ¼W
C308, 314, 319, 539, 543	CE22342-2	Capacitor, Electrolytic 1uF 50V	R316, 333, 508	RF25DC122J	Resistor 1.2K ohm ¼W
C529, 535, 545	CE22342-3	Capacitor, Electrolytic 4.7uF 50V	R537	RF25DC124J	Resistor 120K ohm ¼W
C312, 321, 327	CE22342-4	Capacitor, Electrolytic 10uF 50V	R509	RF25DC151J	Resistor 150 ohm ¼W
C317, 329	CE22342-6	Capacitor, Electrolytic 22uF 35V	R303, 305, 312, 315, 513	RF25DC152J	Resistor 1.5K ohm ¼W
C313, 316, 325, 537	CE22342-8	Capacitor, Electrolytic 47uF 16V	R313	RF25DC153J	Resistor 15K ohm ¼W
C302	CK22344-22	Capacitor, Ceramic 39pF	R503, 518, 535	RF25DC154J	Resistor 150K ohm ¼W
C510, 513	CK22344-2	Capacitor, Ceramic 15pFN750	R552	RF25DC155J	Resistor 1.5M ohm ¼W
C306	CK22344-34	Capacitor, Ceramic 8pF N1500	R546	RF25DC163J	Resistor 16K ohm ¼W
C514	CK22344-5	Capacitor, Ceramic 8pF NPO	R314, 321	RF25DC220J	Resistor 22 ohm ¼W
C330, 501, 517	CK22344-7	Capacitor, Ceramic 12pF N470	R505, 512	RF25DC221J	Resistor 220 ohm ¼W
C520	CK22345-15	Capacitor, Ceramic 21pF	R309, 506	RF25DC222J	Resistor 2.2K ohm ¼W
C305, 508	CK22346-3	Capacitor, Ceramic 2pF	R539, 540	RF25DC223J	Resistor 22K ohm ¼W
C504, 527, 534	CK22350-12	Capacitor, Ceramic 1000pF	R502, 520, 545	RF25DC224J	Resistor 220K ohm ¼W
C536	CK22350-2	Capacitor, Ceramic 150pF	R319, 529, 531	RF25DC272J	Resistor 2.7K ohm ¼W
C307	CK22350-5	Capacitor, Ceramic 270pF	R329	RF25DC273J	Resistor 27K ohm ¼W
C320, 326	CK22350-9	Capacitor, Ceramic 560pF	R528	RF25DC274J	Resistor 270K ohm ¼W
C502, 506, 507, 511, 512, 515, 519, 523, 526, 528, 531, 544	CK22354-1	Capacitor, Ceramic 0.01uF	R525, 532	RF25DC332J	Resistor 3.3K ohm ¼W
C309, 311, 521, 522, 525, 532	CK22354-2	Capacitor, Ceramic 0.02uF	R301	RF25DC334J	Resistor 330K ohm ¼W
C322, 524, 533, 546	CK22354-3	Capacitor, Ceramic 0.1uF	R320, 507	RF25DC392J	Resistor 3.9K ohm ¼W
C318, 323	CP22375-4	Capacitor, Polystyrene 2200pF	R542	RF25DC393J	Resistor 39K ohm ¼W
C530	CT22336-11	Capacitor, Tubular 4pF N3300	R317, 323, 327, 516, 517, 522, 551	RF25DC471J	Resistor 470 ohm ¼W
C505	CV21018	Capacitor, Variable	R304, 311, 511,	RF25DC472J	Resistor 4.7K ohm ¼W
C314	CY22335-12	Capacitor, Mylar 0.022uF	R514	RF25DC562J	Resistor 5.6K ohm ¼W
C332	CY22335-18	Capacitor, Mylar 0.1uF	R308	RF25DC5R6J	Resistor 5.6 ohm ¼W
C328	CY22335-1	Capacitor, Mylar 0.01uF	R302, 302A	RF25DC680J	Resistor 68 ohm ¼W
L505	L50848-18	Choke, R.F. 22uH	R536	RF25DC681J	Resistor 680 ohm ¼W
L301, 506	LC21814-2	Choke, R.F. 3.3uH	R306, 307	RF25DC682J	Resistor 6.8K ohm ¼W
L501	LC21822-2	Choke, R.F. 1.2uH	R533	RF25DC683J	Resistor 68K ohm ¼W
Z501	LC21832	Coil, FM Antenna	R326, 328, 515	RF25DC821J	Resistor 820 ohm ¼W
L504	LC21833-1	Coil, FM Oscillator	R318	RF25DC822J	Resistor 8.2K ohm ¼W
L503	LC21833-2	Coil, FM Mixer	R553	RF25DC823J	Resistor 82K ohm ¼W
L502	LC21833-5	Coil, FM RF	Q303, 305, 505, 506, 509, 510	TR01014	Transistor, NPN BC239C
R331, 504, 524, 543, 544	RF25DC101J	Resistor 100 ohm ¼W	Q301, 302	TR01027	Transistor, A494/BF194
R310, 322, 325, 549	RF25DC102J	Resistor 1K ohm ¼W	Q504	TR01073	Transistor, BF198
R332, 501, 521, 526, 527, 538, 541, 547, 548	RF25DC103J	Resistor 10K ohm ¼W	Q304	TR01074	Transistor, BF199
R324, 330, 519, 523, 534, 530, 550	RF25DC104J	Resistor 100K ohm ¼W	Q502	TR02012	Transistor, SP871
			Q507, 508	TR02020-2	Transistor, 2N4250
			Q503	TR06014	Transistor, FET
			Q501	TR08004	Transistor, MOS FET
			IC501	TR09018	Integrated Circuit FM-IF Monolithic System
			CR301, 501	TR12001-4	Diode, Germanium AA119
			CR302, 502, 503, 504	TR13006-2	Diode, Silicon
			CF501	ZK22110	Ceramic Filter, 10.7 MHz
			Z502	ZZ50210-146	Transformer, FM-IF
			Z303	ZZ50210-156	Transformer, AM-IF
			Z304	ZZ50210-159	Transformer, AM-IF
			Z302	ZZ50210-161	Transformer, AM-IF
			Z503	ZZ50210-180	Transformer, FM-IF
			Z301	ZZ50210-181	Coil, AM Oscillator

# ALIGNMENT

## FM TUNER ALIGNMENT

**FM ALIGNMENT — SELECTOR switch to FM, MUTING OFF pushbutton depressed, STEREO pushbutton depressed, VOLUME control to minimum.**

Maintain generator output as low as possible for suitable indications.

ITEM	GENERATOR	DIAL SETTING	INDICATOR	PROCEDURE
NOTE: The FM IF circuit utilizes a non-tunable ceramic filter which establishes the IF bandpass. To insure symmetrical tuning and selectivity, the IF must be aligned precisely to the center of the filter bandpass, rather than to 10.7 MHz as in conventional LC circuits.				
1. IF ALIGNMENT	Connect 10.7 MHz Sweep Generator to pin 63, ground to pin 5Y. Markers are not required. Set generator output to -12dB (250mV).	Position of non-interference. Connect jumper from pin 26 to pin 5Y on Tuner board.	Scope vertical input to pin 57, ground to pin 5Z. Set vertical sensitivity to 0.5V/cm.	Adjust Z502 top and bottom slugs for maximum gain and best symmetry. See figure for FM IF ALIGNMENT
2. PRELIMINARY DETECTOR ALIGNMENT	Generator connections same as above. Adjust for S-curve display. Set generator output to -20dB. (100mV)	Position of non-interference.	Scope vertical input to pin 58.	Adjust Z503 top slug for maximum gain and best linearity. Adjust Z503 bottom slug for minimum gain and best linearity. See figure for FM DETECTOR ALIGNMENT.  NOTE: Harmonic Distortion test must be performed as part of detector alignment. Remove jumper from between pins 26 and 5Y on Tuner board.
NOTE: Connect 120-ohm composition resistors in series with each lead from the RF generator to match the 50-ohm output to the 300-ohm input impedance. Generator output voltage is reduced to one-half at antenna terminals. Signal voltages specified in this table are generator output levels, not antenna voltages.				
3. FRONT END ALIGNMENT		Tuning knob fully counterclockwise.		Center dial pointer on "0" and cement.
4.	Connect FM generator to FM ANTenna terminals through 120-ohm resistors. Set to 90 MHz. Adjust output for approximately 2 on Field Strength meter.	Center of 90 MHz calibration mark on dial.	Front panel Field Strength meter (M1).	Adjust L504, L503, L502, and Z501 for maximum deflection on Field Strength meter. Reduce generator output to keep Field Strength meter indication at approximately 2.
5.	Set to 106 MHz.	Center of 106 MHz calibration mark on dial.	Same as above.	Adjust C518, C540, C509 and C503 for maximum deflection on Field Strength meter (M1). Reduce generator output to keep Field Strength meter indication at approximately 2. Repeat steps 4 and 5 for optimum alignment.

# ALIGNMENT

## FM TUNER ALIGNMENT

— continued —

ITEM	GENERATOR	DIAL SETTING	INDICATOR	PROCEDURE
6. FINAL DETECTOR ALIGNMENT (MINIMUM THD)	Set generator to receiver frequency. Modulate with 400 Hz $\pm 75$ kHz deviation. Connect generator to FM ANT terminals.	Tune receiver to position of non-interference.	Scope, AC VTVM & Distortion Analyzer to LEFT TAPE 1 OUT. DC VTVM to pins 74 & 75. (Remove jumper between the pins 74 & 75 on TUNER BOARD.)	Reduce generator output for noise to be visible on sine wave. Readjust generator frequency to center noise on positive and negative half cycles. See figure for SYMMETRICAL TUNING.  NOTE: Do not change generator or receiver tuning; proceed with item 7.
7.	Same as above. Increase generator output to 2 mV.	Same as above.	Same as above.	Adjust Z503 top slug for zero indication on DC VTVM. Adjust Z503 bottom slug for minimum THD (0.2% typically). Restore jumper between pins 74 & 75.
8A. MPX OSC. ADJUSTMENT (ON MPX DECODER)	Same as above with output of 2 mV.	Same as above.	Connect frequency counter to pin 72.	Adjust R611 on MPX PCB for 19kHz $\pm 100$ Hz indication on counter.
8B. ALTER-NATE MPX OSC. ADJUSTMENT (ON MPX DECODER)	Same as above.	Same as above.	Scope vertical input to pin 72. Scope horizontal input to MPX generator 19 kHz pilot output.	Adjust R611 for a stable Lissajou display as shown on figure for MPX OSC ADJUSTMENT (19kHz).

## AM TUNER ALIGNMENT

**AM ALIGNMENT — BASS, TREBLE and BALANCE controls to center positions, SPEAKERS switch to PHONES position, SELECTOR switch to AM position, and VOLUME to MIN.**

Maintain generator output as low as possible for suitable indications.

ITEM	GENERATOR	AM DIAL SETTING	INDICATOR	PROCEDURE
1. IF ALIGNMENT	455 kHz sweep generator to pin 70, ground to pin 5X. Use 0.1 uF capacitor in series with generator lead.	Position of non-interference near 1400 kHz.	Scope vertical input to pin 61 ground to pin 5U. Set vertical sensitivity to 0.2 V/cm.	Connect a jumper between pin 67 and pin 5Z. Adjust Z302, Z303, and Z304 top and bottom slugs for maximum gain and best symmetry. Keep signal low enough for noise on response as shown in figure. Disconnect jumper after completion of AM IF Alignment.
2. FRONT END ALIGNMENT	AM generator to EXT AM ANT and GND terminals. Open GND link. Set to 600 kHz. Modulate with 400 Hz; 30% modulation.	Center of 600 kHz calibration mark on dial.	Front panel Field Strength meter (M1).	Adjust Z301 and L300 (antenna) for maximum Field Strength meter indication. Reduce generator output to keep meter reading below 3.
3.	Set to 1400 kHz.	Center of 1400 kHz calibration mark on dial.	Front panel Field Strength meter (M1).	Adjust C303 and C304 for maximum deflection. Keep meter reading below 3. Repeat steps 2 and 3 until optimum alignment is reached.

# ALIGNMENT

## MULTIPLEX DECODER BOARD LAYOUT

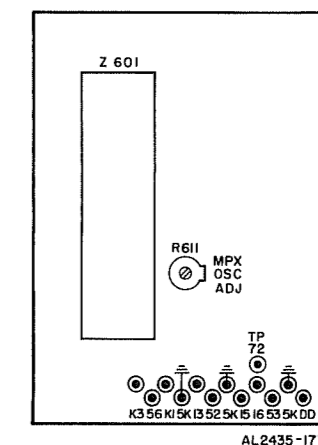

FM-AM TUNER BOARD LAYOUT

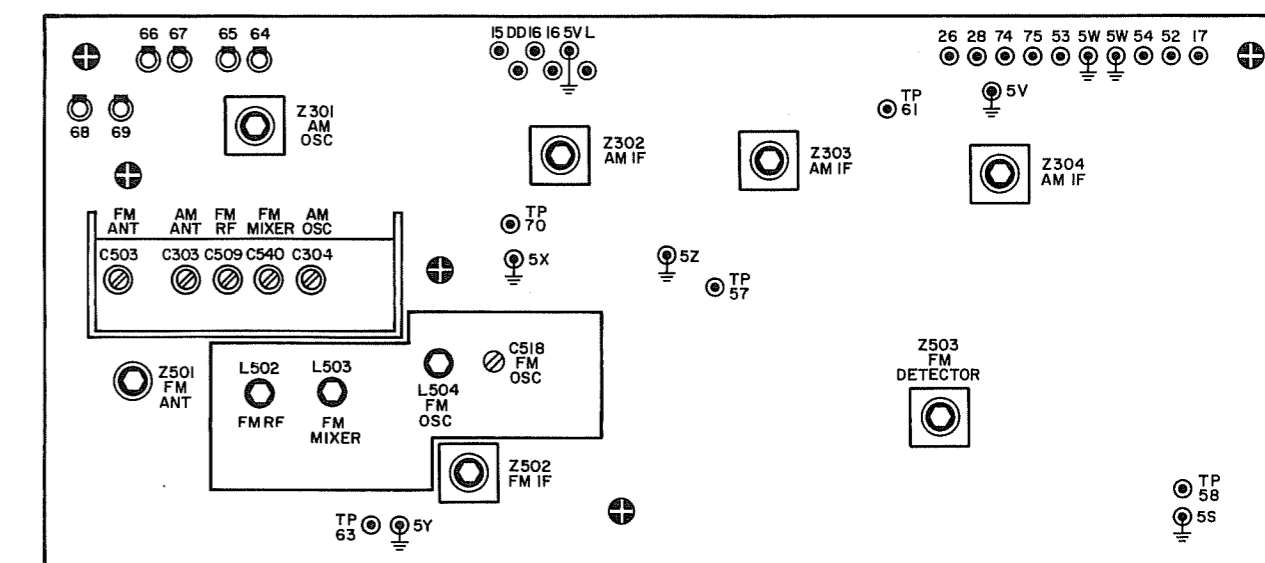

NOTE: CHASSIS GROUNDS ARE COMPLETED THROUGH MOUNTING SCREWS (⊕). TIGHTEN BEFORE ATTEMPTING ALIGNMENT.

AL 2434-177

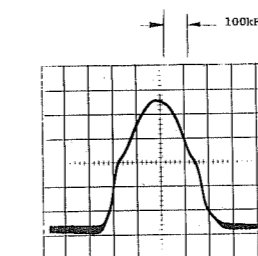

FM IF ALIGNMENT

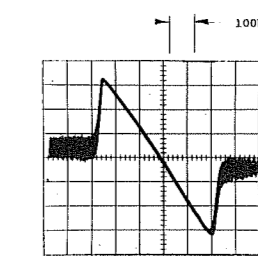

FM DETECTOR ALIGNMENT

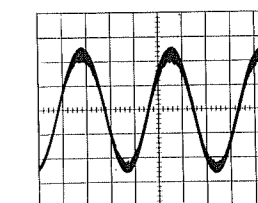

SYMMETRICAL TUNING

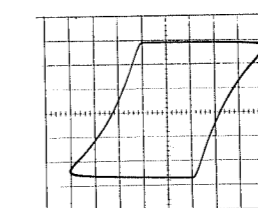

MPX OSC ADJUSTMENT

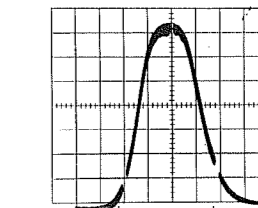

AM IF ALIGNMENT

# FM-AM TUNER SCHEMATIC

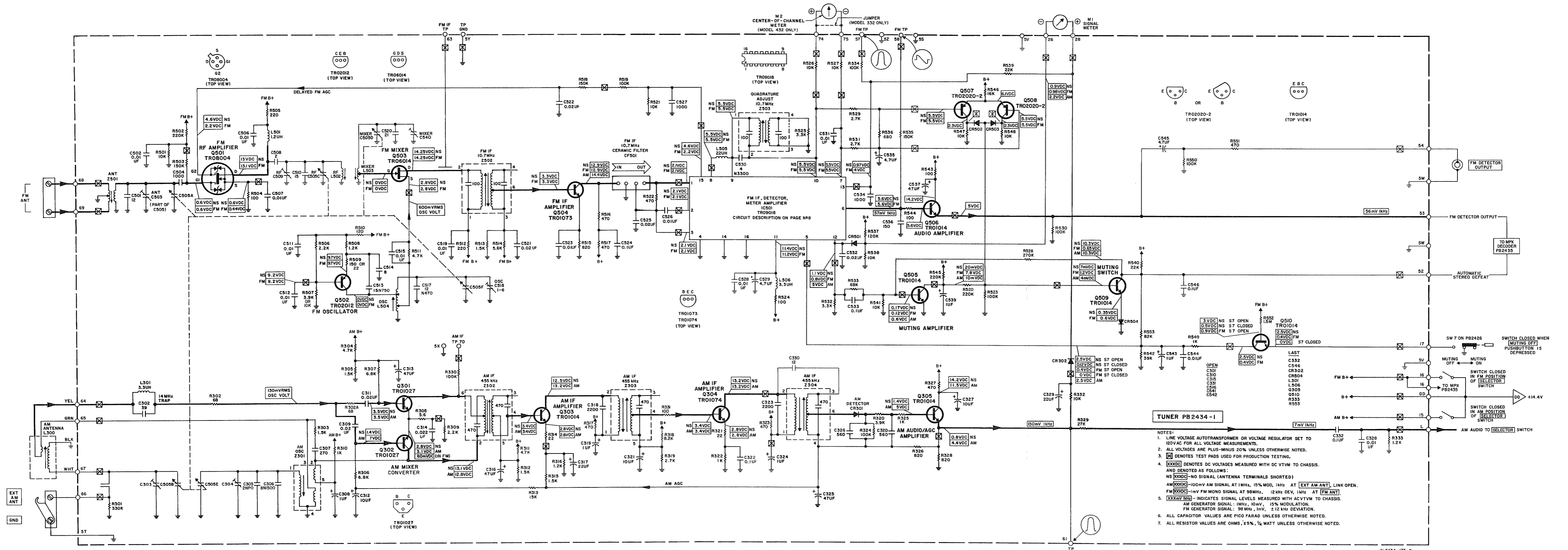

- NOTES:**
1. LINE VOLTAGE AUTOTRANSFORMER OR VOLTAGE REGULATOR SET TO 120VAC FOR ALL VOLTAGE MEASUREMENTS.
  2. ALL VOLTAGES ARE PLUS-MINUS 20% UNLESS OTHERWISE NOTED.
  3.  $\square$  DENOTES TEST PADS USED FOR PRODUCTION TESTING.
  4.  $\square$  DENOTES DC VOLTAGES MEASURED WITH DC VTVM TO CHASSIS. AND DENOTES AS FOLLOWS:  
 NS  $\square$  - NO SIGNAL (ANTENNA TERMINALS SHORTED)  
 AM  $\square$  - 100mV AM SIGNAL AT 1MHz, 15% MOD, 1kHz AT [EXT AM ANT], LINK OPEN.  
 FM  $\square$  - 1mV FM MONO SIGNAL AT 98MHz, 12kHz DEV, 1kHz AT [FM ANT].  
 FM GENERATOR SIGNAL: 98 MHz, 1mV, 12 kHz DEVIATION.
  5.  $\square$  - INDICATES SIGNAL LEVELS MEASURED WITH ACVTVM TO CHASSIS.  
 AM GENERATOR SIGNAL: 1MHz, 10mV, 15% MODULATION.  
 FM GENERATOR SIGNAL: 98 MHz, 1mV, 12 kHz DEVIATION.
  6. ALL CAPACITOR VALUES ARE PICO FARAD UNLESS OTHERWISE NOTED.
  7. ALL RESISTOR VALUES ARE OHMS,  $\pm 5\%$ , 1/4 WATT UNLESS OTHERWISE NOTED.

# SELECTOR SWITCH AND PREAMPLIFIER SCHEMATIC

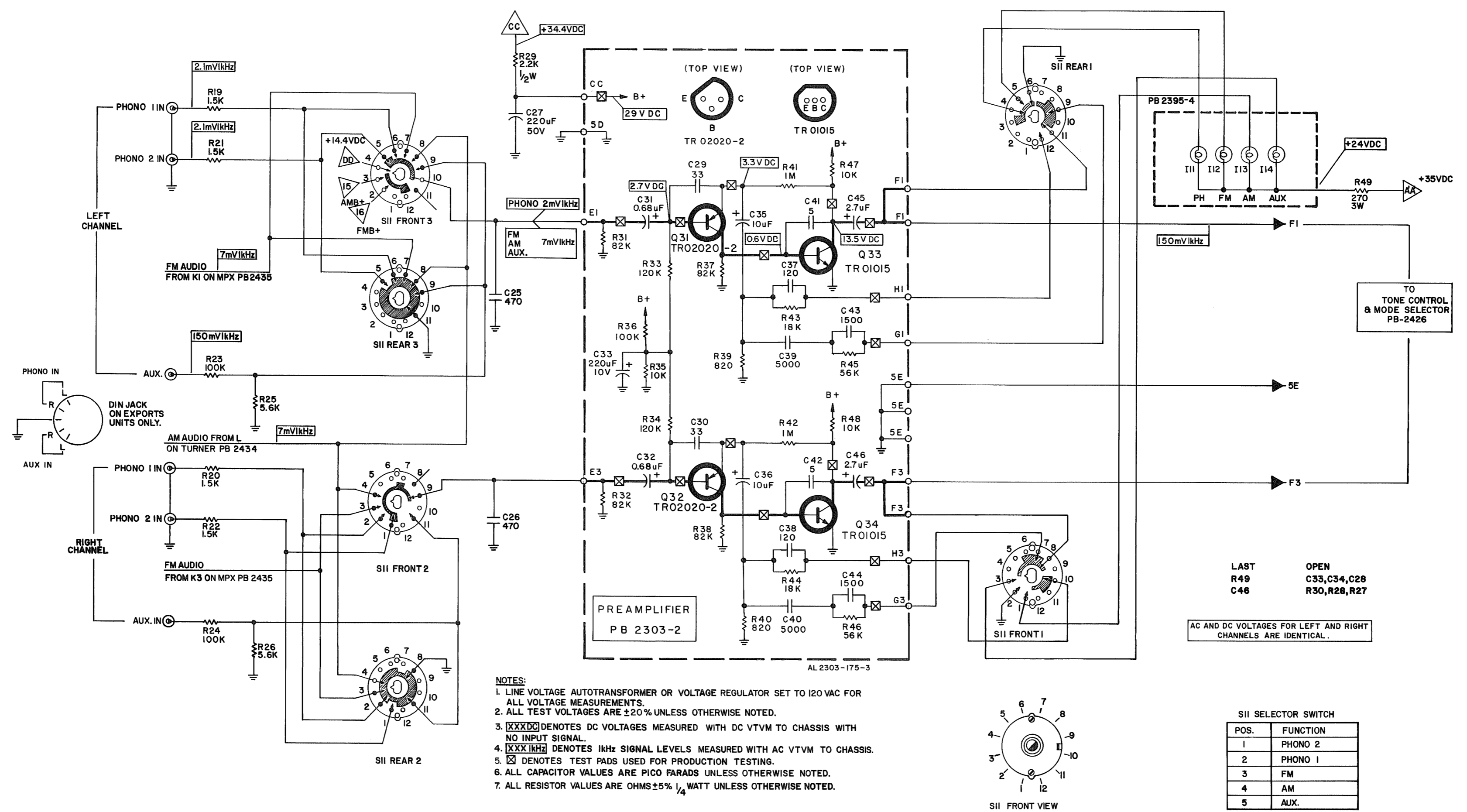

- NOTES:**
1. LINE VOLTAGE AUTOTRANSFORMER OR VOLTAGE REGULATOR SET TO 120 VAC FOR ALL VOLTAGE MEASUREMENTS.
  2. ALL TEST VOLTAGES ARE  $\pm 20\%$  UNLESS OTHERWISE NOTED.
  3. [XXXDC] DENOTES DC VOLTAGES MEASURED WITH DC VTVM TO CHASSIS WITH NO INPUT SIGNAL.
  4. [XXXkHz] DENOTES kHz SIGNAL LEVELS MEASURED WITH AC VTVM TO CHASSIS.
  5. [X] DENOTES TEST PADS USED FOR PRODUCTION TESTING.
  6. ALL CAPACITOR VALUES ARE PICO FARADS UNLESS OTHERWISE NOTED.
  7. ALL RESISTOR VALUES ARE OHMS  $\pm 5\%$   $\frac{1}{4}$  WATT UNLESS OTHERWISE NOTED.

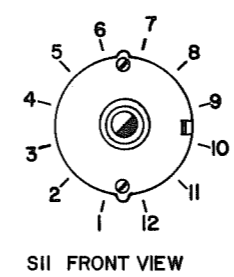

SII SELECTOR SWITCH

POS.	FUNCTION
1	PHONO 2
2	PHONO 1
3	FM
4	AM
5	AUX.

LAST OPEN  
R49 C33,C34,C28  
C46 R30,R28,R27

AC AND DC VOLTAGES FOR LEFT AND RIGHT CHANNELS ARE IDENTICAL.

# TONE CONTROL AND MODE SELECTOR SCHEMATIC

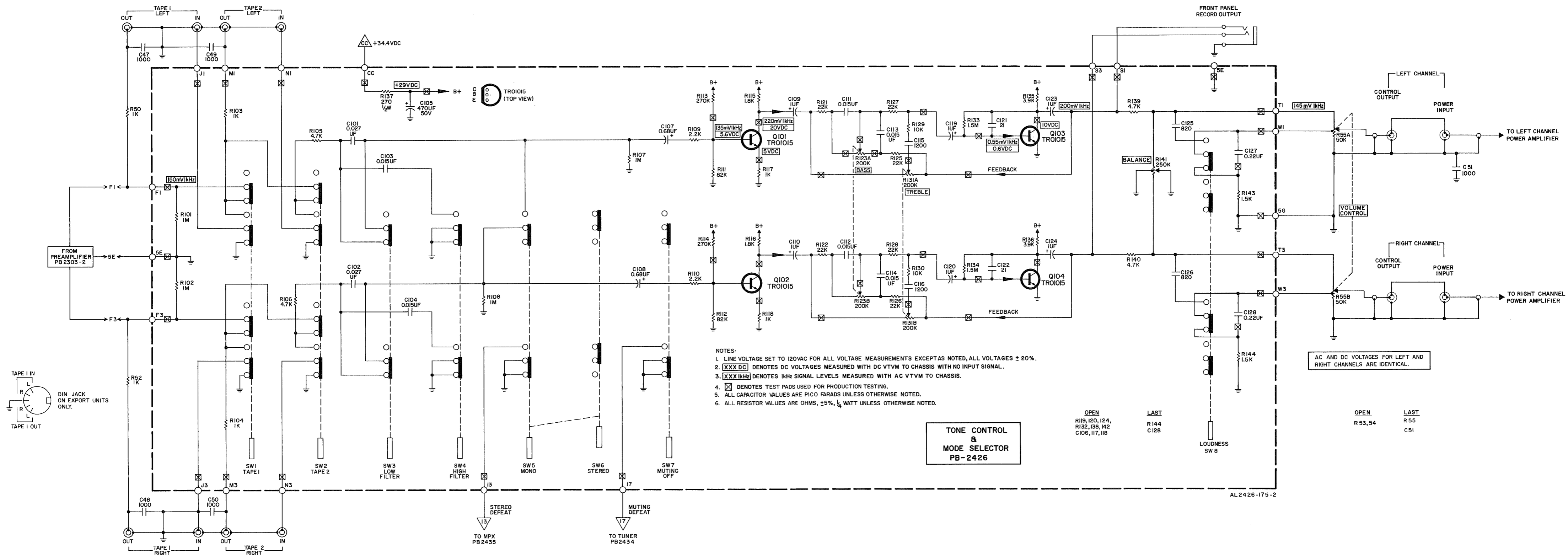

- NOTES:
1. LINE VOLTAGE SET TO 120VAC FOR ALL VOLTAGE MEASUREMENTS EXCEPT AS NOTED, ALL VOLTAGES  $\pm 20\%$ .
  2. [XXX DC] DENOTES DC VOLTAGES MEASURED WITH DC VTVM TO CHASSIS WITH NO INPUT SIGNAL.
  3. [XXX kHz] DENOTES kHz SIGNAL LEVELS MEASURED WITH AC VTVM TO CHASSIS.
  4. [X] DENOTES TEST PADS USED FOR PRODUCTION TESTING.
  5. ALL CAPACITOR VALUES ARE PICO FARADS UNLESS OTHERWISE NOTED.
  6. ALL RESISTOR VALUES ARE OHMS,  $\pm 5\%$ ,  $\frac{1}{4}$  WATT UNLESS OTHERWISE NOTED.

TONE CONTROL &  
MODE SELECTOR  
PB-2426

OPEN  
R119, I20, I24,  
R132, I38, I42  
C106, I17, I18

LAST  
R144  
C128

OPEN  
R53, 54

LAST  
R55  
C51

AC AND DC VOLTAGES FOR LEFT AND  
RIGHT CHANNELS ARE IDENTICAL.

AL 2426-175-2

# NOTES

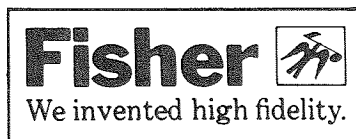
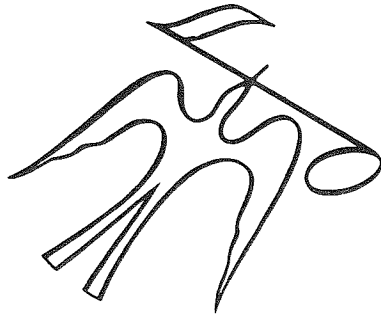

**FISHER RADIO • 11-40 45th ROAD • LONG ISLAND CITY • NEW YORK 11101**