

# SERVICE MANUAL

PRICE \$1.

450

SERIAL NUME  
BEGINNING 1

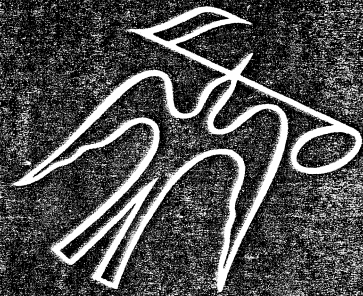

# The Fisher<sup>®</sup>

## 450-T<sup>™</sup>

= 505.

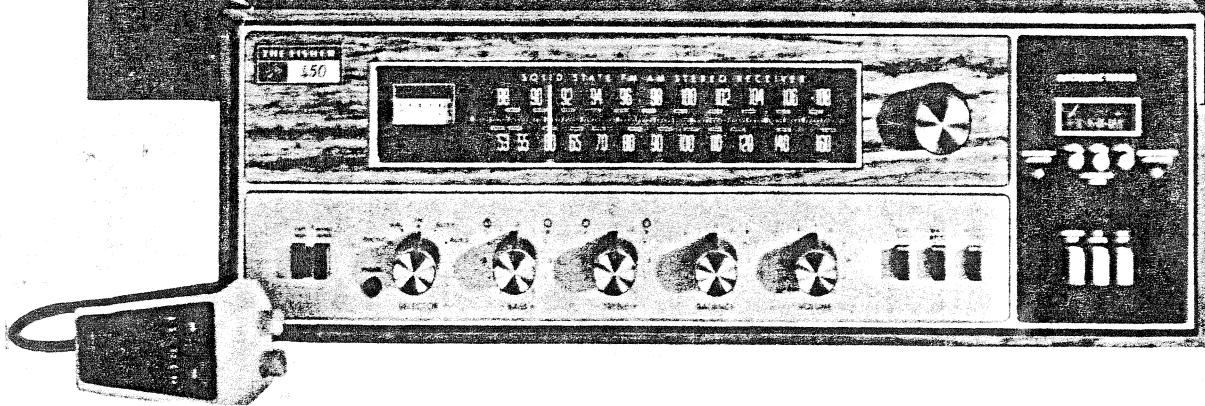

**WORLD LEADER IN HIGH QUALITY STEREO**

## TEST EQUIPMENT AND SERVICE TIPS

The following equipment is required to completely test and align modern high-fidelity amplifiers, tuners, and receivers.

Line Voltage Autotransformer or Voltage Regulator	10.7 MHz Sweep Generator
DC Vacuum Tube Volt ohmmeter	Multiplex Generator (preferably with RF output)
Accurately Calibrated AC Vacuum Tube Voltmeter	455 kHz Sweep Generator
Oscilloscope ((Flat to 100 kHz Minimum)	Ferrite Test Loop Stick
Low-Distortion Audio (Sine Wave) Generator	2 – Full Range Speakers for Listening Tests
Intermodulation Distortion Analyzer	Stereo Source – Turntable, Tape Recorder, etc.
Harmonic Distortion Analyzer	Soldering Iron with Small Tip, Fully Insulated from AC Line
2 – Load resistors, 8-Ohms, 100 Watt (Minimum Rating)	Suction Desoldering Tool
AM/FM Signal Generator	

**CAUTION:** This precision high-fidelity instrument should be serviced only by qualified personnel, trained in the repair of transistor equipment and printed circuitry.

Many of these items are included only as a reminder – they are normal procedures for experienced technicians. Shortcuts may be taken, but these often cause additional damage to transistors, circuit components, or printed circuit boards.

**SOLDERING:** A well-tinned, hot, clean soldering iron tip will make soldering easier, without causing damage to the printed circuit board or the components mounted on it. Regular use of a sponge cleaner will maintain a clean soldering surface. The heat available at the tip, (not the wattage of the iron) is important. Some 50-watt irons reach temperatures of 1,000° F, while others will hardly melt solder. Small-diameter tips should be used for single solder connections, pyramid and chisel tips for large areas.

Always disconnect the AC power cord from the line when soldering. Turning the power switch OFF is not sufficient. Power-line leakage paths, through the heating element of the iron, may destroy transistors.

**PARTS REMOVAL:** If a part is not being returned for in-warranty factory replacement, it may be cut in half (with diagonal cutting pliers) to make removal easier. Multiple terminal parts, such as IF transformers, or electrolytic capacitors, should be removed using special de-soldering tips made especially for this purpose. Removing solder from terminals, reduces the possibility of breaking the printed circuit board when the part is removed.

**ACCIDENTAL SHORTS:** A clean working area, free of metal particles, screws, etc., is an important preventive in avoiding servicing problems. Screws, removed from the chassis during servicing, should be stored in a box until needed. While a set is operating, it takes only an instant for a base-to-collector short to destroy a transistor (and others direct-coupled to it). In the time it takes for a dropped machine screw, washer, or screwdriver, to contact a pair of socket terminals (or terminal and chassis), a transistor can be ruined.

**SOLID-STATE DEVICES:** Integrated Circuits contain the equivalent of many circuit parts, including transistors, diodes, resistors, and capacitors. The preferred troubleshooting procedure requires isolating the trouble to one stage using AC signal tracing methods. Once the suspected stage is located, the DC voltages at the input and output leads are measured to give an accurate indication of the operating conditions of the IC. DO NOT use an ohmmeter to check continuity with the IC mounted on the printed circuit board. Forward biasing the internal junctions within the IC may burn out the transistors. Do not replace a defective IC until all external resistors, capacitors, and transformers are checked first, to prevent the replacement IC from failing immediately due to a defect in the connecting components. Solder and unsolder each lead separately using a pliers or other heat sink on the lead to prevent damage from excessive heat. Check that the leads are

connected to the correct locations on the printed circuit board before turning the set on.

Whenever possible, a transistor tester should be used to determine the condition of a transistor or diode. Ohmmeter checks do not provide conclusive data, and may even destroy the junction(s) within the device.

Never attempt to repair a transistor power amplifier module until the power supply filter-capacitors are fully discharged.

If an output or driver transistor becomes defective (opens or shorts), always check ALL direct-coupled transistors and diodes in that channel. In addition, check the bias pot., and other parts in the bias network, before installing replacement transistors. All output and driver transistors in one channel may be destroyed if the bias network is defective. After parts replacement, always check the bias adjustment for specified idling current.

In some applications, replacement of transistors must be made from the same beta group as the original type. The beta group is indicated by a colored marking on the transistor. Be sure to include this information when ordering replacement transistors.

When mounting a replacement power transistor, be sure the bottom of the flange, mica insulator, and the surface of the heat sink, are free of foreign matter. Dust and grit will prevent flat contact, reducing heat transfer to the heat sink. Metallic particles can puncture the insulator, cause a short, and destroy the transistor.

Silicone grease must be used between the transistor and the mica insulator, and between the mica and the heat sink, for best heat transfer. Use Dow-Corning DC-3, or an equivalent compound made for power transistor heat conduction.

Use care when making connections to speakers and output terminals. To reduce the possibility of shorts, lugs should be used on the exposed ends, or stranded wire should be tinned to prevent frayed wire ends. Current in the speakers and output circuitry is quite high – poor contacts, or small sized wire, can cause significant power losses in the system. For wire lengths greater than 30 feet, 16 AWG, or heavier, should be used.

**VOLTAGE MEASUREMENTS:** All voltages are measured with the line voltage adjusted to 120 volts. All measured voltages are  $\pm 10\%$ . DC voltages are measured to ground with a VTVM, with no signal input unless otherwise noted. AC signal voltages are measured under the conditions specified on the schematic.

**ALIGNMENT PROCEDURES:** DO NOT attempt realignment unless the required test equipment is available, and the alignment procedure is thoroughly understood.

BECAUSE ITS PRODUCTS ARE SUBJECT TO CONTINUOUS IMPROVEMENT, FISHER RADIO RESERVES THE RIGHT TO MODIFY ANY DESIGN OR SPECIFICATION WITHOUT NOTICE AND WITHOUT INCURRING ANY OBLIGATION.

## CONTENTS

	PAGE		PAGE
REQUIRED TEST EQUIPMENT	2	CONTROL AMPLIFIER	8
MECHANICAL DISASSEMBLY	3	PREAMPLIFIER	9
DIAL STRINGING	4	TUNER ALIGNMENT	10-11
HARMONIC DISTORTION TEST	4	AM-FM IF, MPX, METER, MUTING	12-13
CHASSIS LAYOUT	5	AM RF	14
POWER SUPPLY	6	FM RF	14
MAIN CHASSIS	7	AUTOSCAN	15
POWER AMPLIFIER	8	PUSHBUTTON-SWITCH BOARDS	16

## REMOVING DRESS PANEL

- (1) Remove the five screws securing top cover to chassis and heat sink. Remove cover.
- (2) Remove the two AUTOSCAN meter leads from pins R9 and Q9. Label each lead for reference.
- (3) Gently pull SELECTOR, BASS, TREBLE, BALANCE, VOLUME, and TUNING knobs from control shafts. Remove hex nuts from shafts and remove panel.
- (4) Reverse procedure for reassembly.

## REPLACING DIAL GLASS

- (1) Remove dress panel. Refer to REMOVING DRESS PANEL procedure.
- (2) Loosen the four retaining screws, and rotate retainers. Remove dial glass.
- (3) Reverse procedure for reassembly.

## REPLACING DIAL LAMPS

- (1) Remove dress panel. Refer to REMOVING DRESS PANEL procedure.
- (2) Snap out defective lamp from spring clip. Place new lamp (FR No. I21B406-1) into clip so that unpainted side of lamp faces edge of dial glass.
- (3) Replace dress panel.

## REPLACING STEREO BEACON AND METER LAMPS

**NOTE:** The lamp assembly on rear of tuning meter contains the meter lamp and STEREO BEACON lamp, and must be replaced as a complete unit.

- (1) Remove the five screws securing top cover to chassis and heat sink. Remove cover.
- (2) Gently pull the four wires from terminal pins on top rear of tuning meter. Label each wire for reference.
- (3) Gently unsnap lamp assembly from top rear of meter. Center replacement assembly (FR No. M21C604-2) between flanges and press firmly in place.
- (4) Reconnect the four wires to their associated terminal pins on replacement assembly. Replace cover.

## REPLACING AUTOSCAN LAMP

- (1) Remove the five screws securing top cover to chassis and heat sink. Remove cover.
- (2) Squeeze edges of molded lamp assembly and pull through bracket.
- (3) Disconnect leads and label for reference.
- (4) Snap in replacement lamp assembly (FR No. AS21410-4) and connect leads. Replace cover.

## REPLACING TUNING METER

- (1) Remove the five screws securing top cover to chassis and heat sink. Remove cover.
- (2) Gently unsnap lamp assembly from top rear of meter. Pull assembly away from meter but do not disconnect leads.
- (3) Gently pry meter off back of dial panel, and scrape residual adhesive from panel. Disconnect meter leads and label for reference.
- (4) Peel backing from one side of replacement adhesive mounting pad (FR No. E51A219), and affix it to replacement meter (FR No. M21C604-1). Peel backing from remaining side of pad, align meter face over panel cutout, and firmly press meter to back of panel.
- (5) Center lamp assembly between flanges on meter back, and press firmly in place. Connect meter leads.
- (6) Check meter calibration. Refer to FM ALIGNMENT procedure. Replace cover.

## REPLACING AUTOSCAN METER

- (1) Remove the five screws securing top cover to chassis and heat sink. Remove cover.
- (2) Remove meter leads from pins R9 and Q9. Label each lead for reference.
- (3) Gently pry meter off back of dress panel, and scrape residual adhesive from panel.
- (4) Peel backing from one side of replacement adhesive mounting pad (FR No. EM51293), and affix it to replacement meter (FR No. MC21610). Peel backing from remaining side of pad, align meter face over panel cutout, and firmly press meter to back of panel.
- (5) Connect meter leads. Replace cover.

## REMOVING P. C. BOARDS

To remove board from nylon mounts, squeeze loop of mounting clip (using pliers), and lift each corner of board. To remount board, align mounting holes over clips, and press firmly.

To remove any board containing front-panel controls and switches, use the following procedure:

- (1) Remove dress panel. Refer to REMOVING DRESS PANEL procedure.
- (2) Remove the five screws securing bottom cover to chassis. Remove cover.
- (3) a. Remove CONTROL AMPLIFIER board by removing hex nuts from BASS, TREBLE, BALANCE and VOLUME controls.  
b. Remove PUSHBUTTON-SWITCH boards by removing the two screws holding each switch to chassis. Three additional screws must be removed from MODE/MONITOR board.

## DIAL STRINGING

- (1) Remove screws securing top and bottom covers to chassis and heat sink. Remove covers. Remove pointer.
- (2) Rotate tuning capacitor fully CCW. Loosen screw in center of drum and remove old dial cord.
- (3) Tie end of new cord to end of dial spring. Fasten spring to bottom right ear inside drum. See illustration.
- (4) Run cord through rim slot into underside of groove 3.
- (5) Pull cord taut and wrap 2 turns CCW around tuning shaft. See detail.
- (6) Guide cord under and around pulley "A", and around pulleys "B" and "C". Keep cord taut.
- (7) Rotate drum fully CW, allowing cord to wind onto drum.
- (8) Guide cord under drum into groove 5, through rim slot, and under washer.
- (9) Pull cord taut, and tighten screw.
- (10) Rotate drum CCW and CW to distribute tensioning.
- (11) Repeat steps (9) and (10) until spring is tensioned.
- (12) Place cord over and under tabs on pointer (see detail), and place pointer on top of rail.
- (13) Turn tuning shaft fully CCW. Slide pointer to (0) while holding tuning shaft fully CCW. Cement pointer to cord to prevent slippage. Allow cement to thoroughly dry.
- (14) Check dial calibration. Refer to FM/AM ALIGNMENT.

## HARMONIC DISTORTION TEST

## CAUTION:

- (A) Measure the power of one channel at a time.
- (B) Limit measurements to 10 minutes.
- (C) Use a load with a minimum power rating of 100 watts.

Set BASS, TREBLE, and BALANCE to their center positions. Set SELECTOR to AUX 1. Depress MAIN SPKRS switch. Unplug AC power cord.

- (1) Connect a low-distortion sine-wave generator to the LEFT AUX 1 IN jack. Set generator frequency to 1,000 Hz, and output level to minimum.
- (2) Connect an 8-ohm load resistor between the LEFT SPEAKERS MAIN and COMMon terminals. In parallel with the load resistor, connect the input leads of an HD analyzer and the input leads of an accurately calibrated AC VTVM.
- (3) Connect AC power cord and rotate VOLUME to maximum.
- (4) Increase generator level for 55 watts output (21.0 V RMS across 8-ohm load). HD meter should read 0.5% or less.
- (5) Repeat preceding steps for right channel.

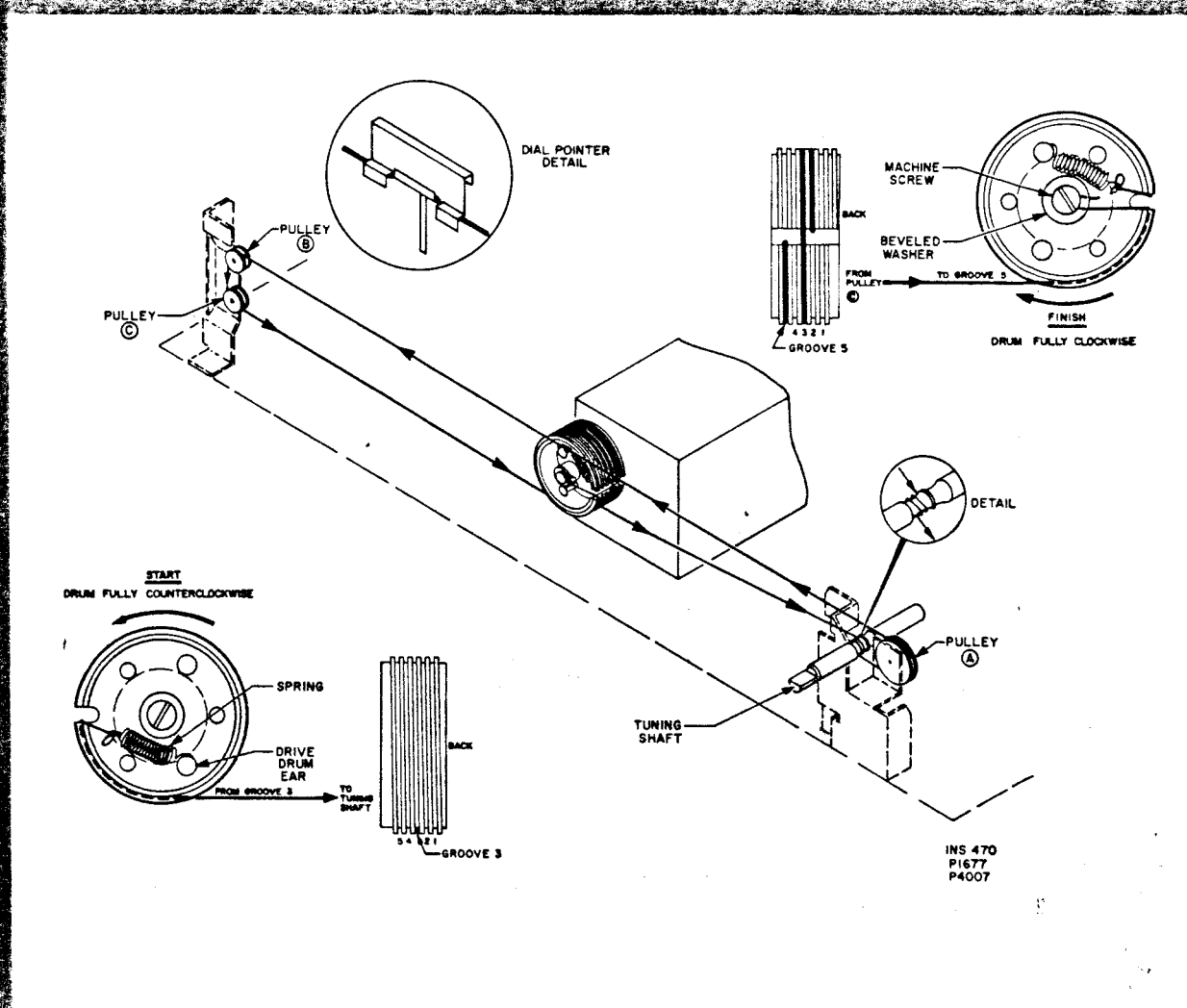

# CHASSIS LAYOUT

TOP VIEW

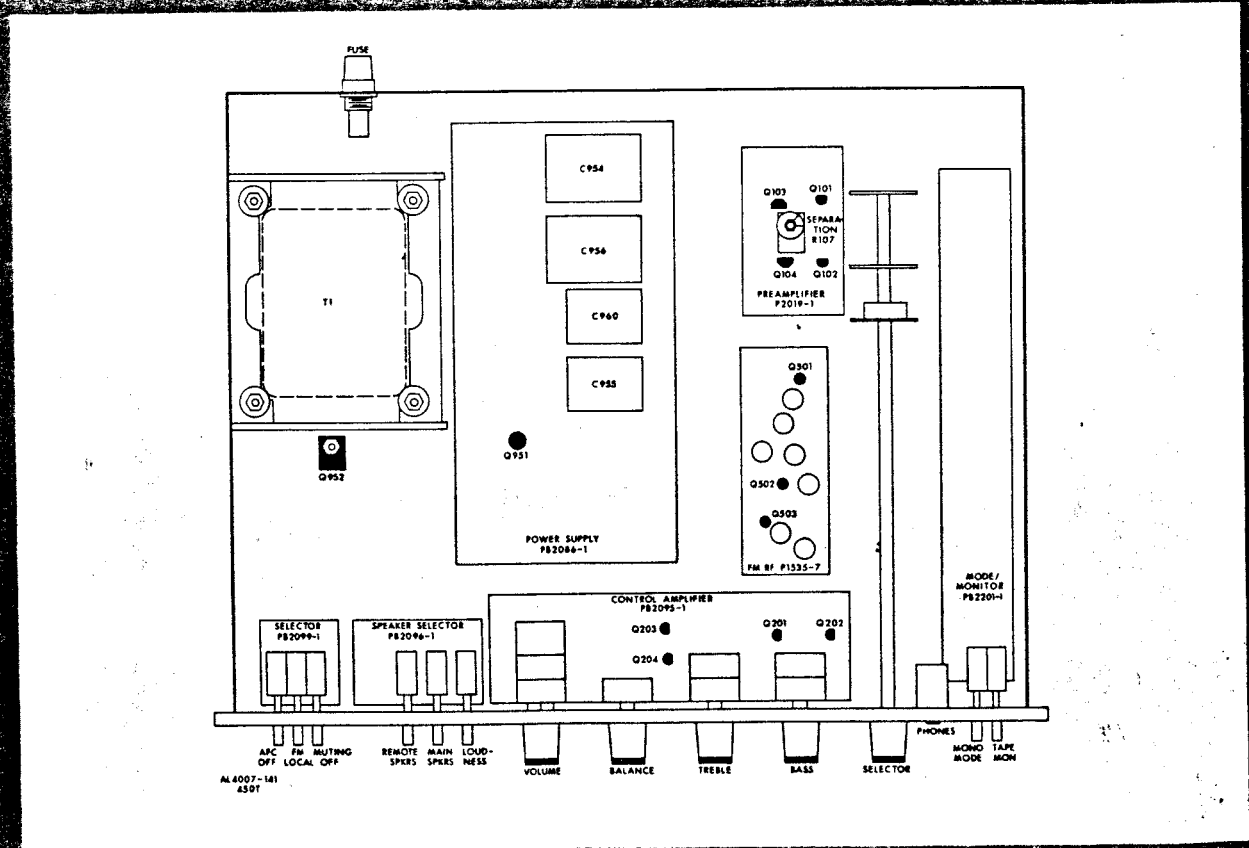
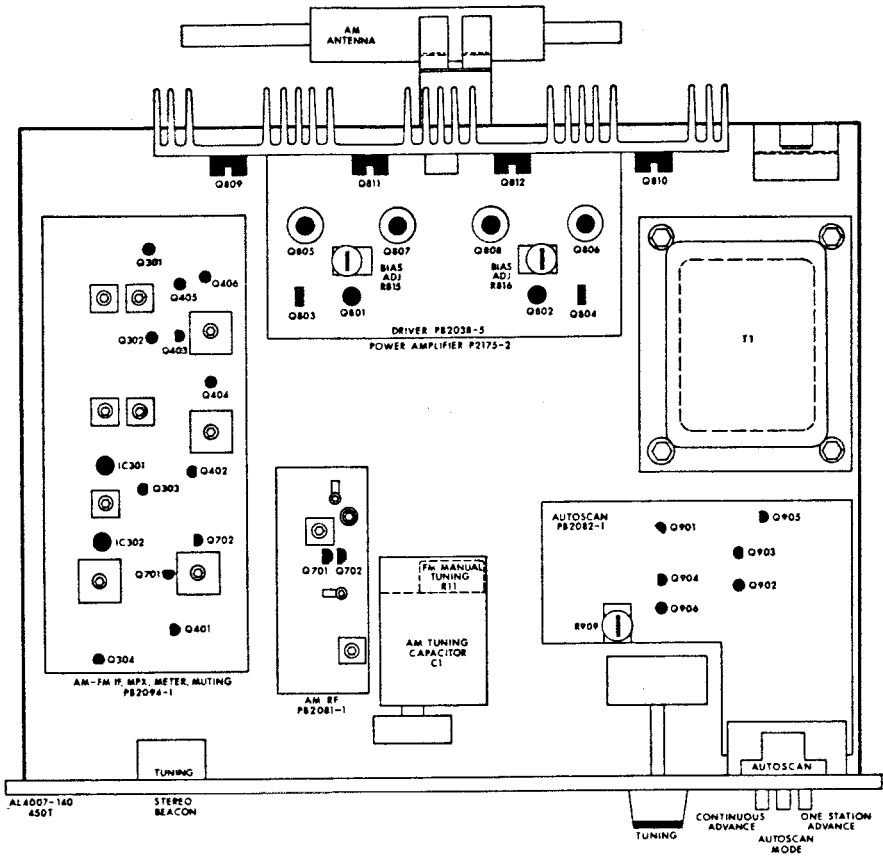

BOTTOM VIEW

POWER SUPPLY 2086 - 1

6

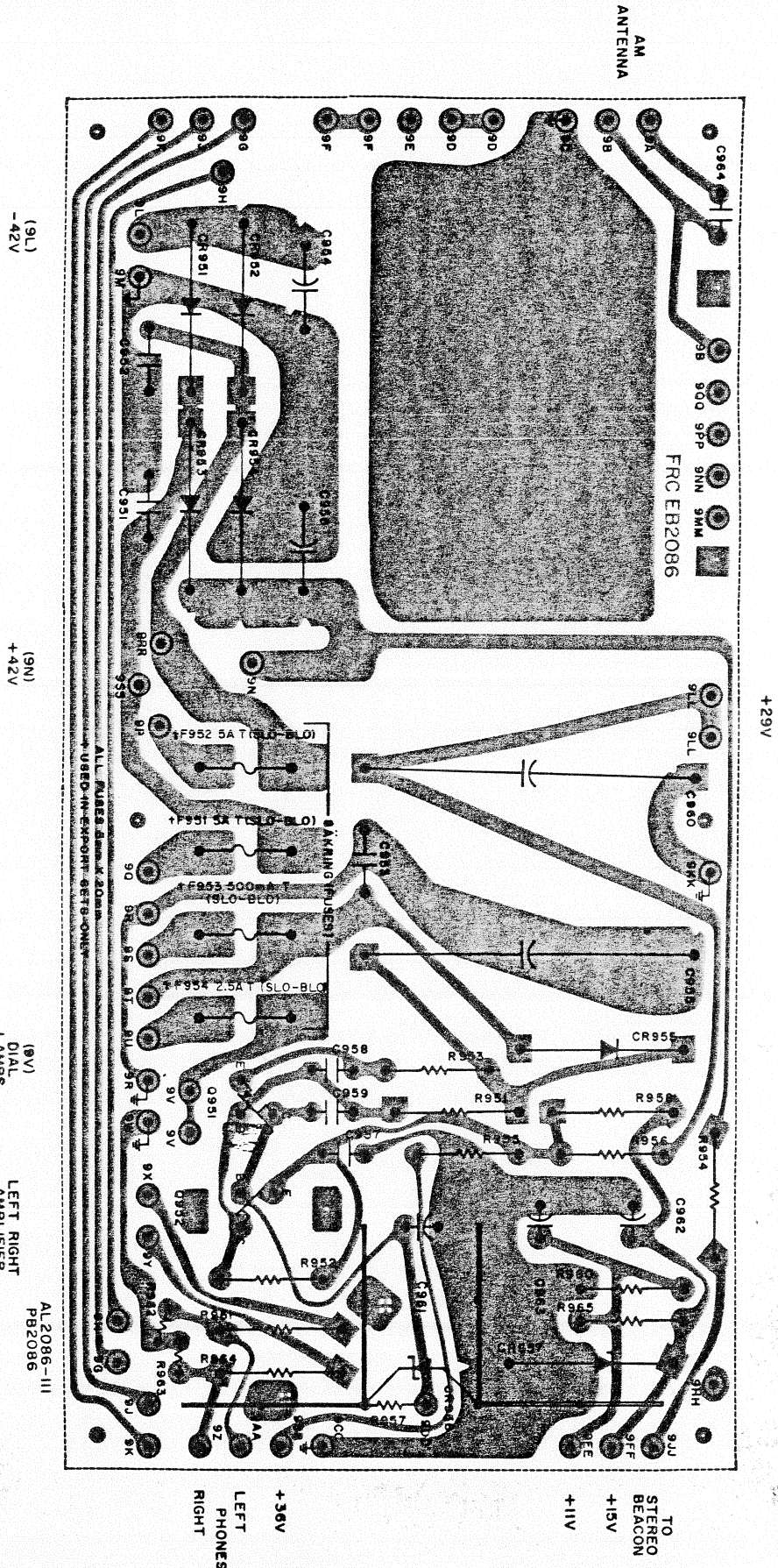

SCHEMATIC SHOWN ON MAIN CHASSIS DIAGRAM

# FM RF 1535-7

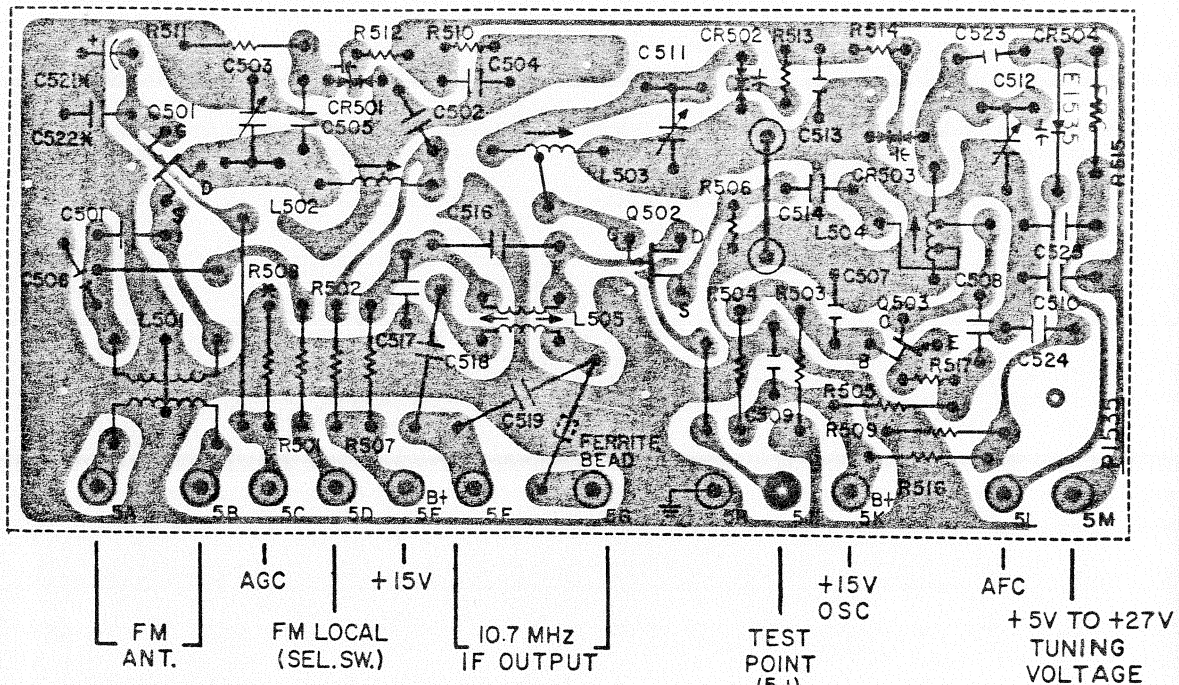
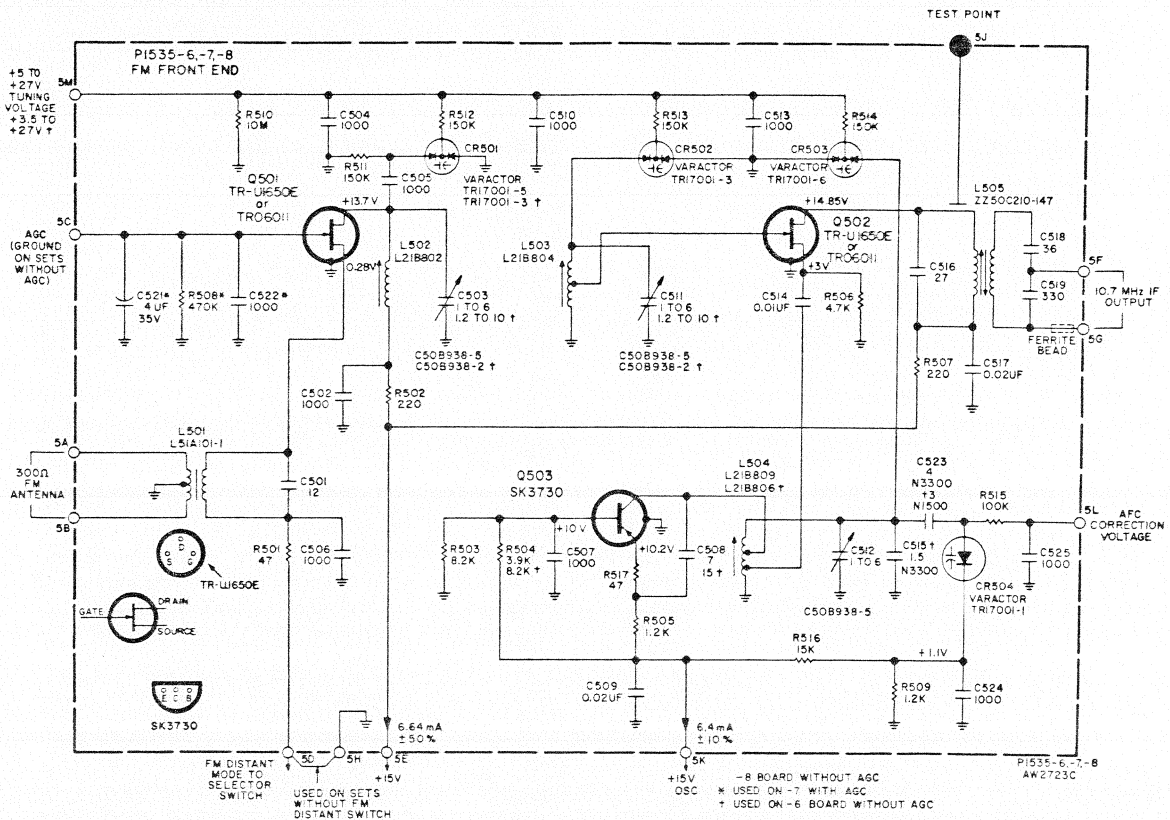

\* SEE SCHEMATIC

PI535  
1I1535B113D

# CONTROL AMPLIFIER 2095 - 1

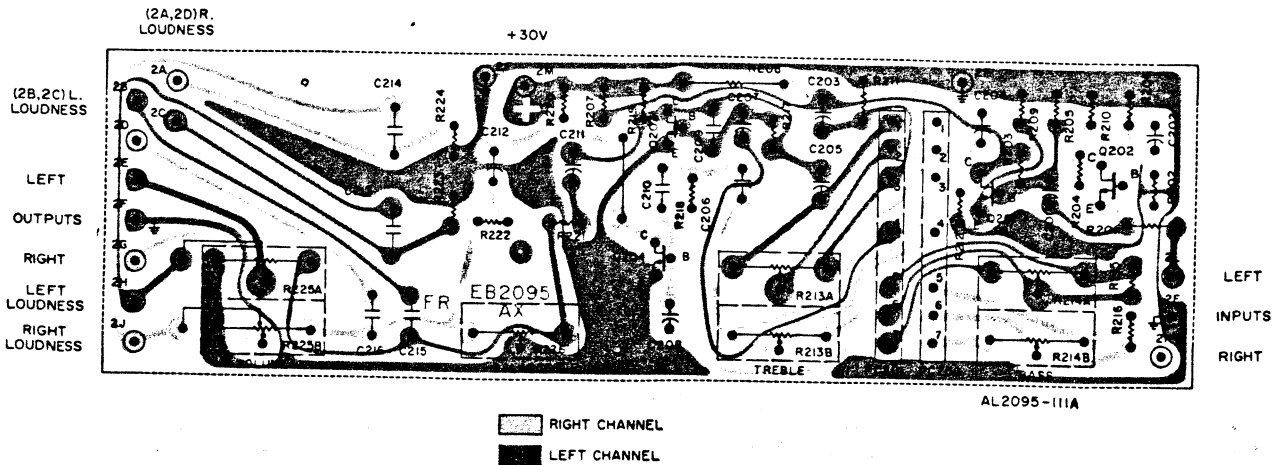
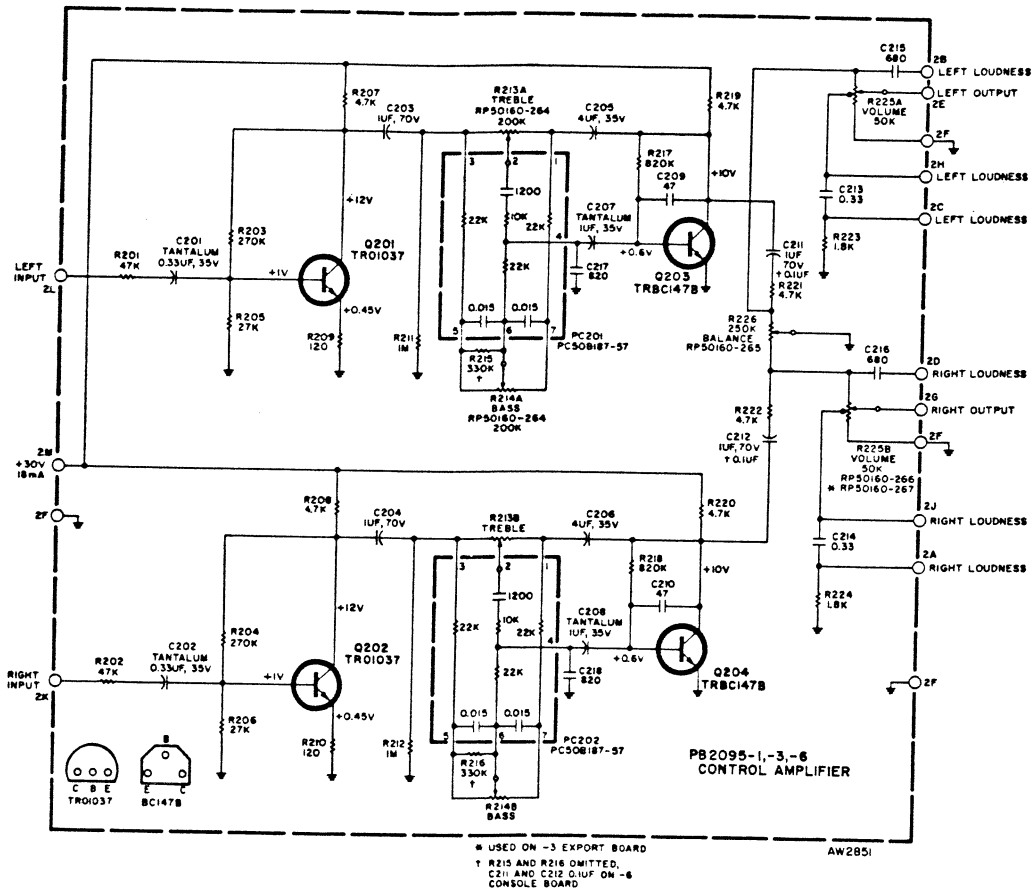



PREAMPLIFIER 2019 - 1

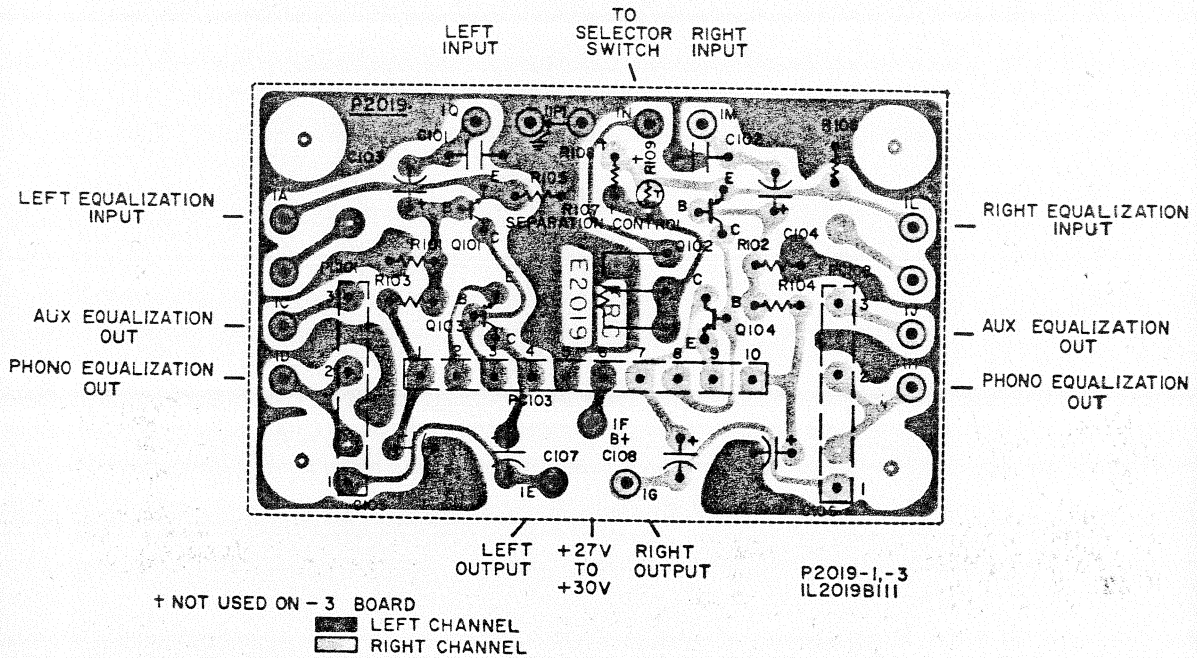
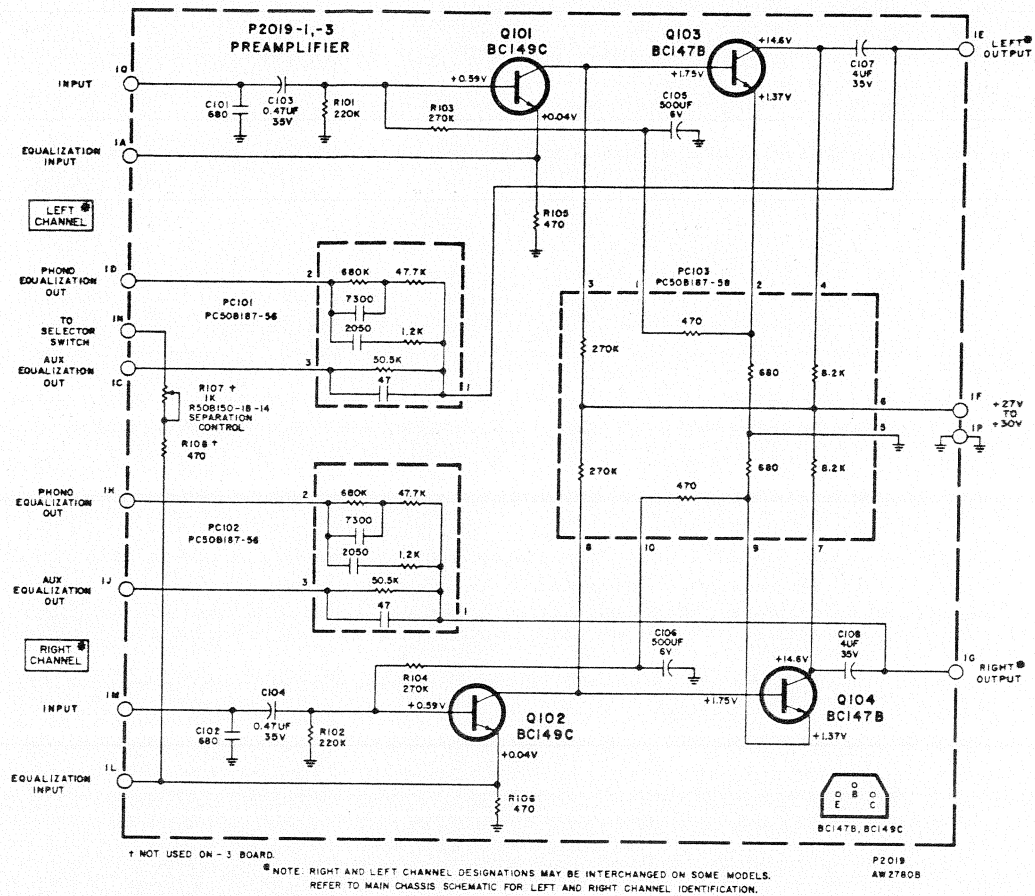

## TUNER ALIGNMENT

Turn TUNING knob fully CCW. If pointer is not centered on (0), reposition and cement pointer. Except as noted, maintain generator level as low as possible during alignment.

## FM ALIGNMENT

- (1) Set SELECTOR to FM. Turn VOLUME to minimum. Depress MUTING OFF and AFC OFF switches. Release AUTOSCAN MODE switch (manual tuning operation).
- (2) Disconnect jumper from pin 3N. Connect AC input of scope to pin 3N, scope ground to pin 3G.
- (3) Connect 10.7MHz sweep generator to pin 5J, generator ground to pin 5H.
- (4) Adjust top and bottom cores of Z305, Z304, Z302, and L505 for maximum gain and symmetry. See FM IF illustration.
- (5) Increase generator level to full output (approximately 100mV). If necessary, slightly readjust top core of Z305 to center 10.7MHz marker (see FM-IF LIMITED illustration).
- (6) Reconnect jumper to pin 3N. Connect a 100k resistor in series with AC input of scope and connect to pin 3M, scope ground to pin 3L.
- (7) Adjust bottom and top cores of Z306. See FM DETECTOR illustration.
- (8) Connect DC VTVM to pin 3M. Use lowest (most sensitive) range. Readjust top core of Z306 for 0 VDC. Disconnect test equipment.
- (9) Connect an accurately calibrated DC VTVM to pin A9 (on AUTOSCAN board.)
- (10) Center dial pointer on 88MHz fiducial mark (1.1 on logging scale). Using a small screwdriver, adjust R11A (on back of AM tuning capacitor) for exactly 4.3 VDC. Disconnect DC VTVM.
- (11) Connect an FM signal generator to FM ANTenna terminals through 120-ohm composition resistors, one in series with each lead from the generator. Connect a scope and an AC VTVM to the LEFT RCDR 1 OUT jack.
- (12) Set generator frequency and dial pointer accurately to 90MHz (1.87 on logging scale). Modulate generator with 400Hz,  $\pm 75$ kHz deviation. Adjust top and bottom core of L504, and top core of L503, and L502 for maximum AC, and maximum on front panel tuning meter. Maintain generator level for front panel tuning meter reading between 2 and 3.
- (13) Set generator frequency and dial pointer accurately to 104MHz (7.53 on logging scale). Adjust C512, C511, and C503 for maximum AC and maximum on front panel tuning meter.
- (14) Repeat steps (12) and (13) for accurate dial calibration and maximum audio.
- (15) Modulate generator with 400Hz,  $\pm 25$ kHz deviation.
- (16) Reduce generator output until noise interference is visible on sine wave. Adjust generator frequency to center noise interference on positive and negative half-cycles. See SYMMETRICAL TUNING illustration.
- (17) Turn-on muting circuit by releasing MUTING OFF switch. Scope trace should disappear. Slowly increase generator output until trace reappears. Generator output should be between 20uV and 50uV (10uV to 25uV at antenna terminals through 120-ohm resistors).
- (18) Increase generator output to 1mV. Adjust R328 FM METER ADJ. for front panel tuning meter reading of 4.5.
- (19) Increase generator level to 10mV. Connect MPX generator composite output to FM signal generator EXTERNAL MODULATION input. Modulate generator signal with 19kHz,  $\pm 7.5$ kHz deviation (10% pilot, no audio).
- (20) Connect DC VTVM to pin 4G. Tune receiver accurately to generator frequency. Adjust Z401, and Z402 for maximum DC (2.5 to 4 VDC).
- (21) Modulate generator with MPX composite signal,  $\pm 75$ kHz deviation (90% 1kHz audio, 10% 19kHz pilot). Modulate right channel only.
- (22) Connect an AC VTVM to LEFT RCDR 1 OUT jack. Connect another AC VTVM to RIGHT RCDR 1 OUT jack. Connect scope input to pin 4K.
- (23) Using an ohmmeter, temporarily set R107 SEPAR-

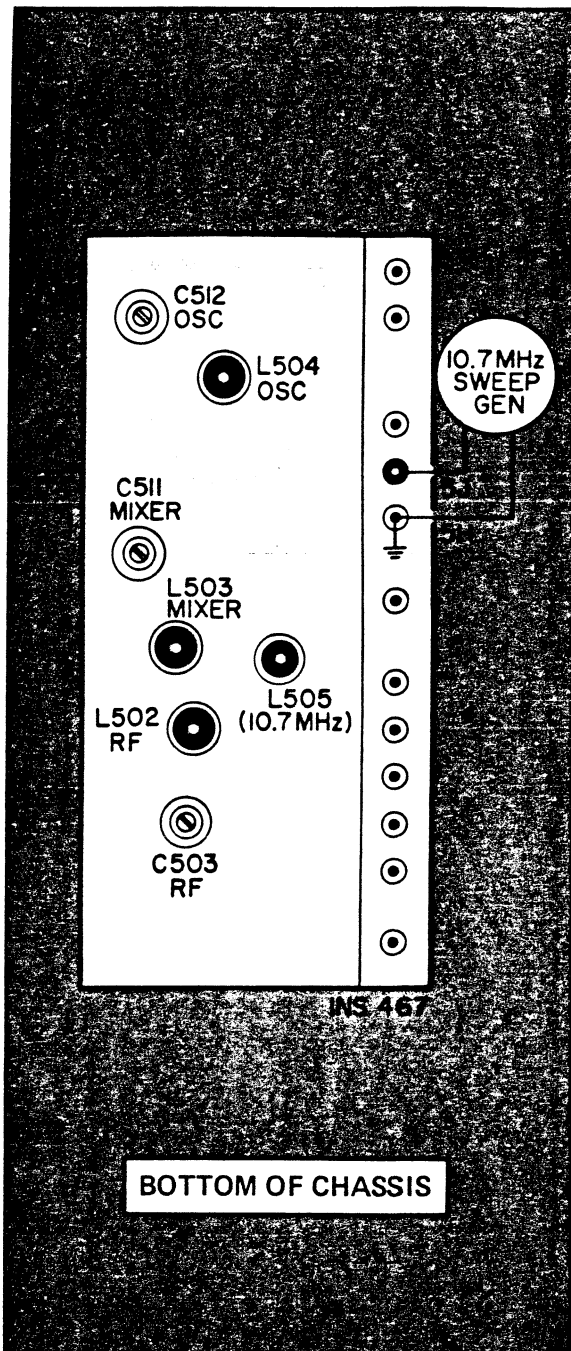

- ATION CONTROL (on preamplifier board) to maximum resistance. Adjust Z403 for maximum scope amplitude and as straight a base-line as possible (see MPX illustration). Left channel AC should be minimum.
- (24) Modulate left channel only. Adjust R107 SEPARATION CONTROL for minimum AC on right channel (at least 30dB below left channel).
  - (25) Modulate right channel only. Left channel should be at least 30dB below right channel.
- NOTE: If separation measurements are not within 3dB of each other, readjust Z402 slightly, and repeat (23) through (25).

## AM ALIGNMENT

- (1) Set SELECTOR to AM, VOLUME to minimum.
- (2) Connect 455kHz sweep generator to pin 7L, generator ground to pin 7K. Use a 0.1uF capacitor in series with generator lead.
- (3) Connect scope input to pin 3Q, scope ground to pin 3G.

TUNER ALIGNMENT

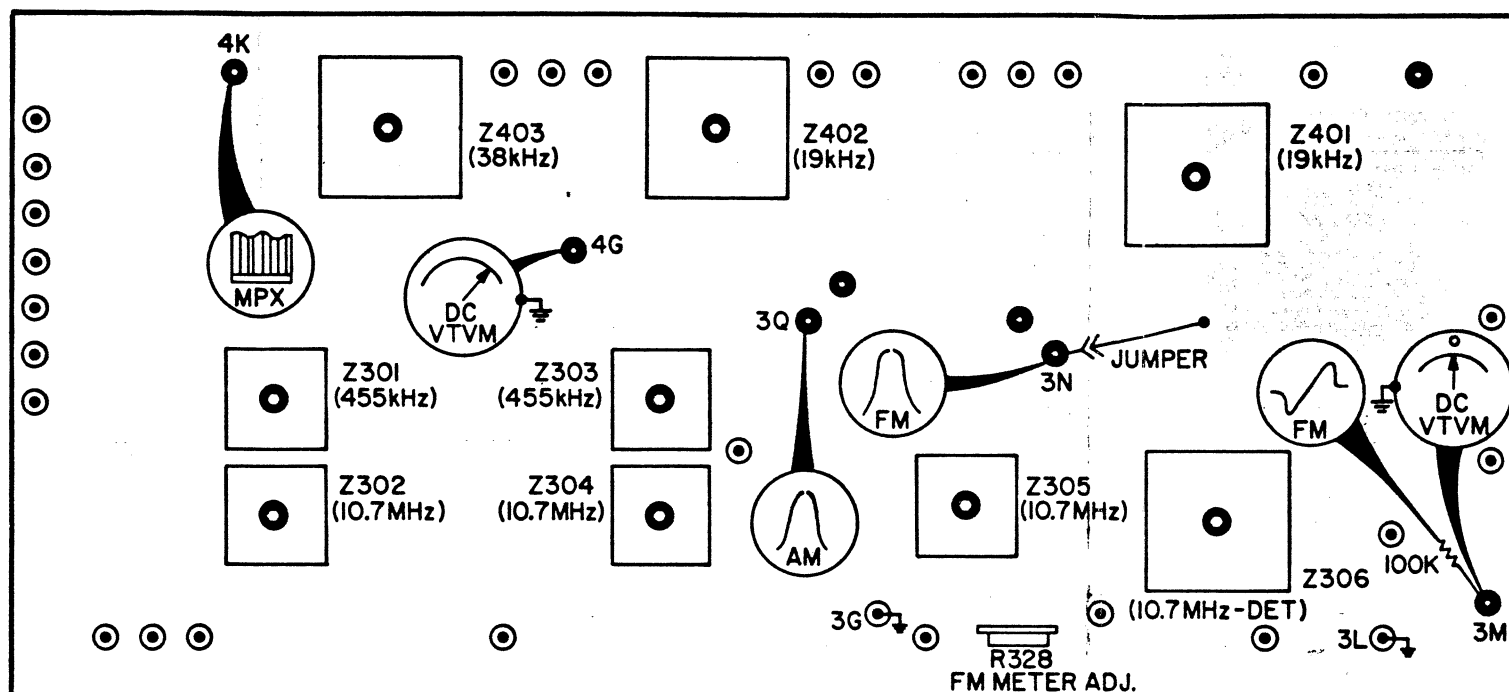

INS 496A

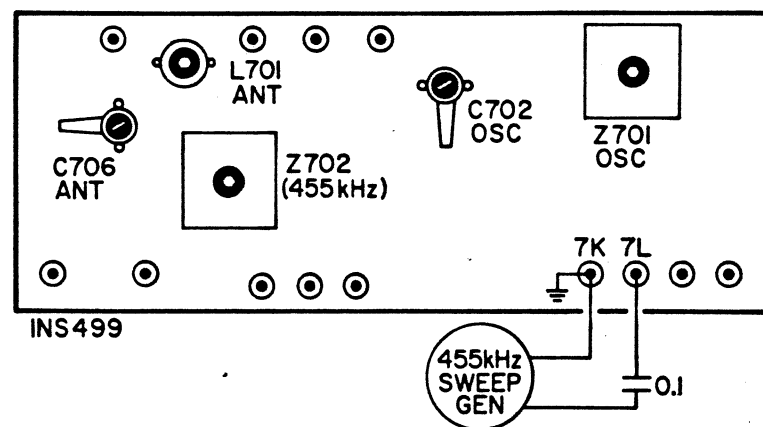

INS 499

TOP OF CHASSIS

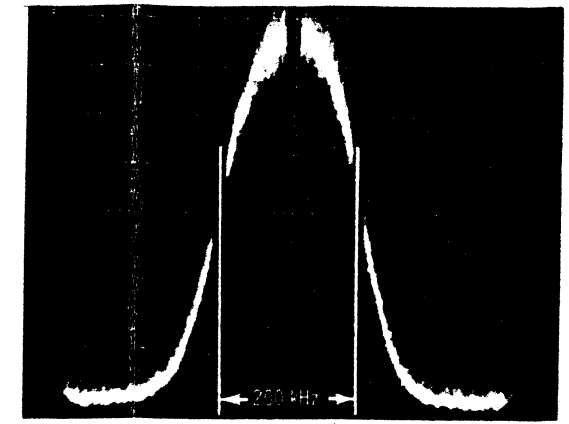

FM IF

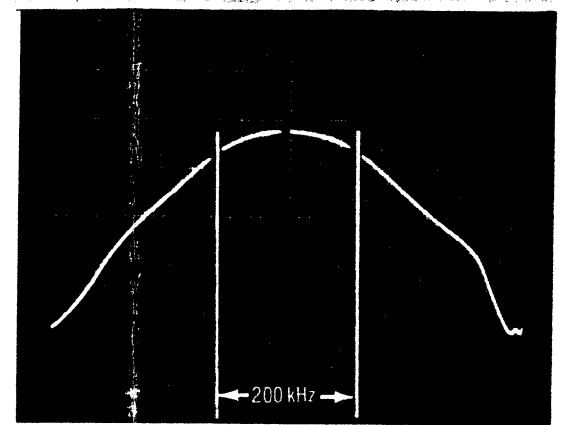

FM IF-LIMITED

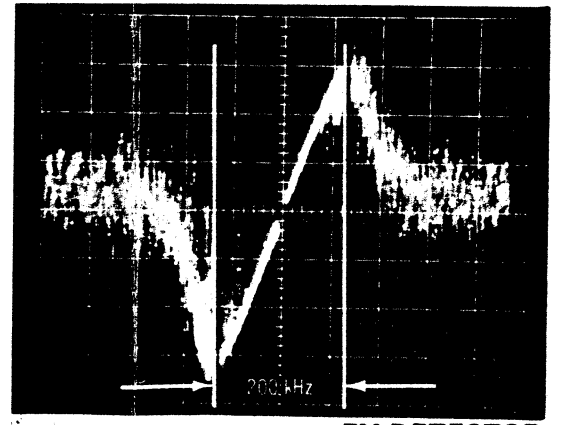

FM DETECTOR

- (4) Adjust top and bottom cores of Z303, Z301, and Z702 for maximum gain and symmetry. See AM IF illustration. Disconnect test equipment.
- (5) Open AM ANTenna GND link. Connect an AM signal generator to the AM ANT and GND terminals. Use a 220pF capacitor in series with generator lead. Connect a scope and an AC VTVM to LEFT RCDR 1 OUT jack.
- (6) Set generator frequency and dial pointer to 600kHz (2.1 on logging scale). Modulate generator with 400Hz, 30% modulation. Adjust Z701 for maximum audio.
- (7) Set generator frequency and dial pointer to 1400kHz (8.47 on logging scale). Adjust C702 for maximum audio.
- (8) Repeat steps (6) and (7) for accurate dial calibration and maximum gain.
- (9) Reset generator and pointer to 600kHz. Adjust L701 for maximum audio.
- (10) Reset generator and pointer to 1400kHz. Adjust C706 for maximum audio.
- (11) Repeat steps (9) and (10) for maximum gain.

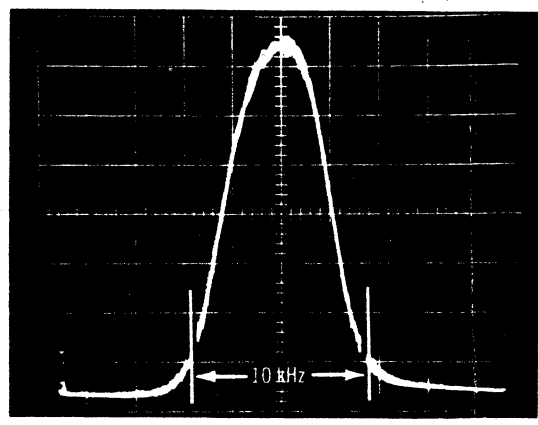

AM IF

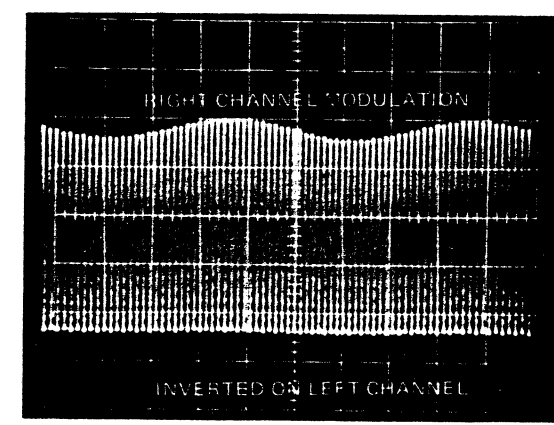

MPX

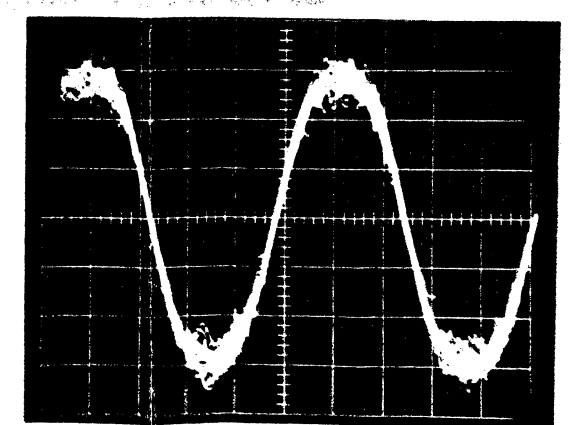

SYMMETRICAL TUNING

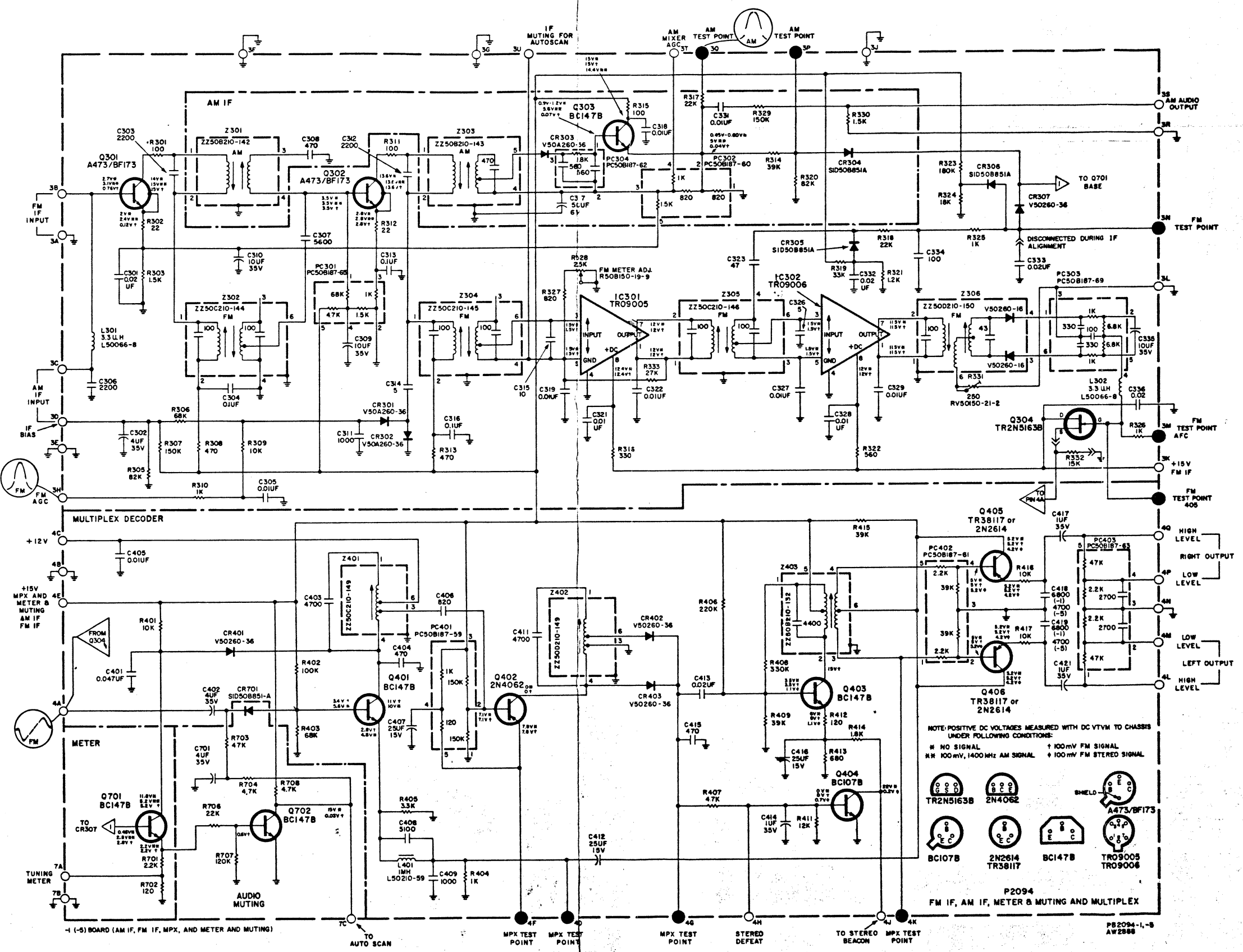

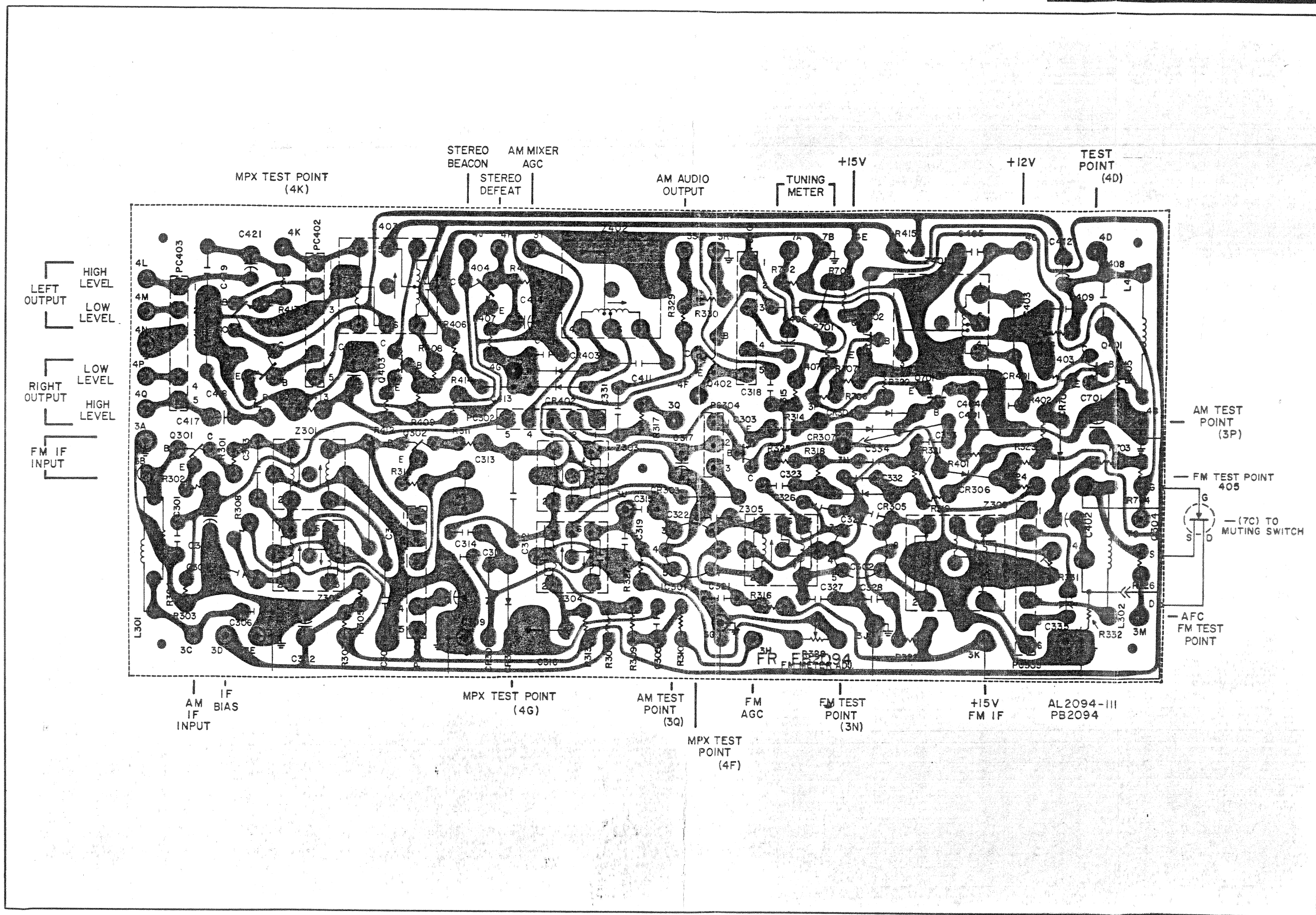

AM RF 2081 - 1

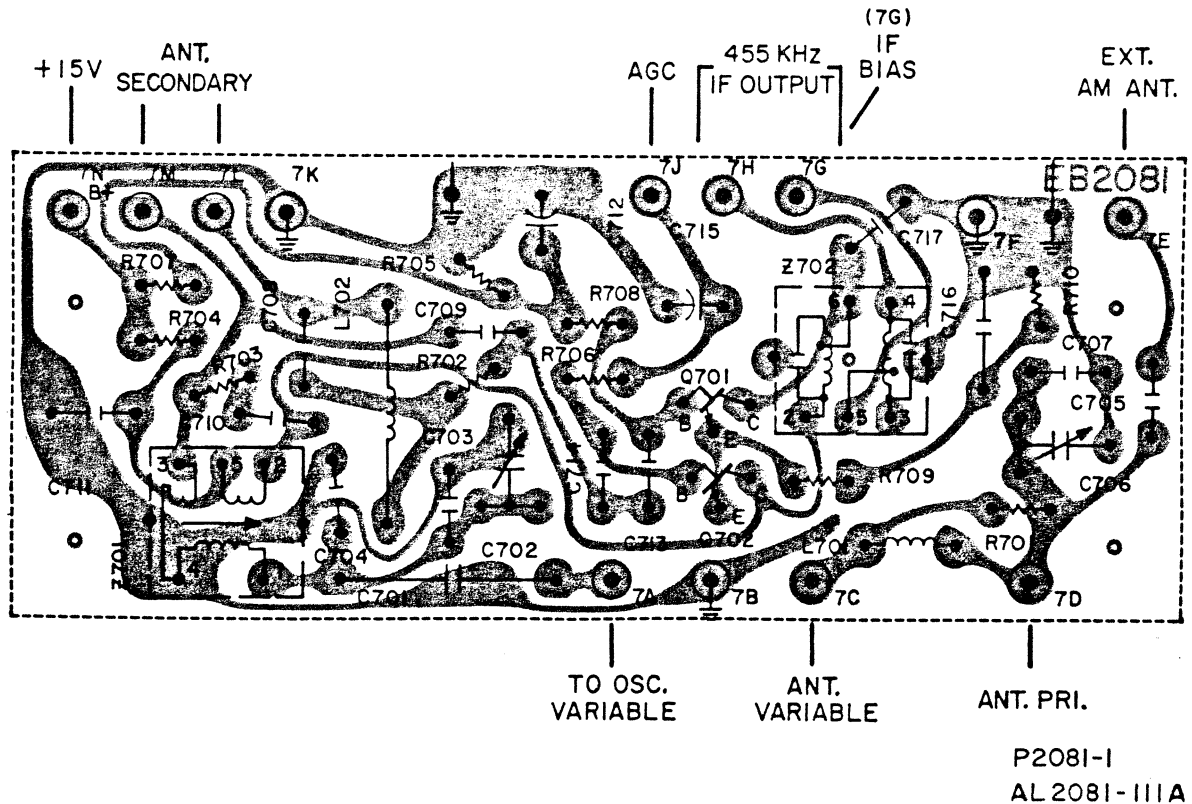
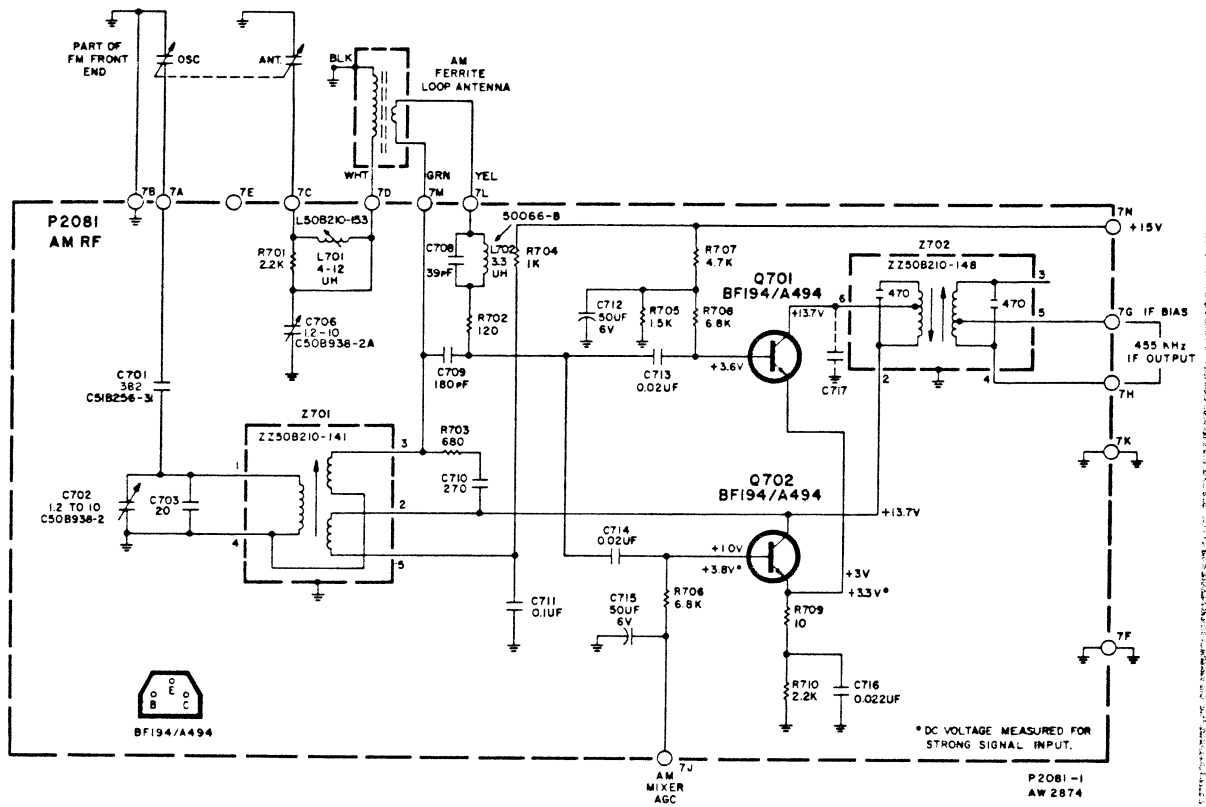

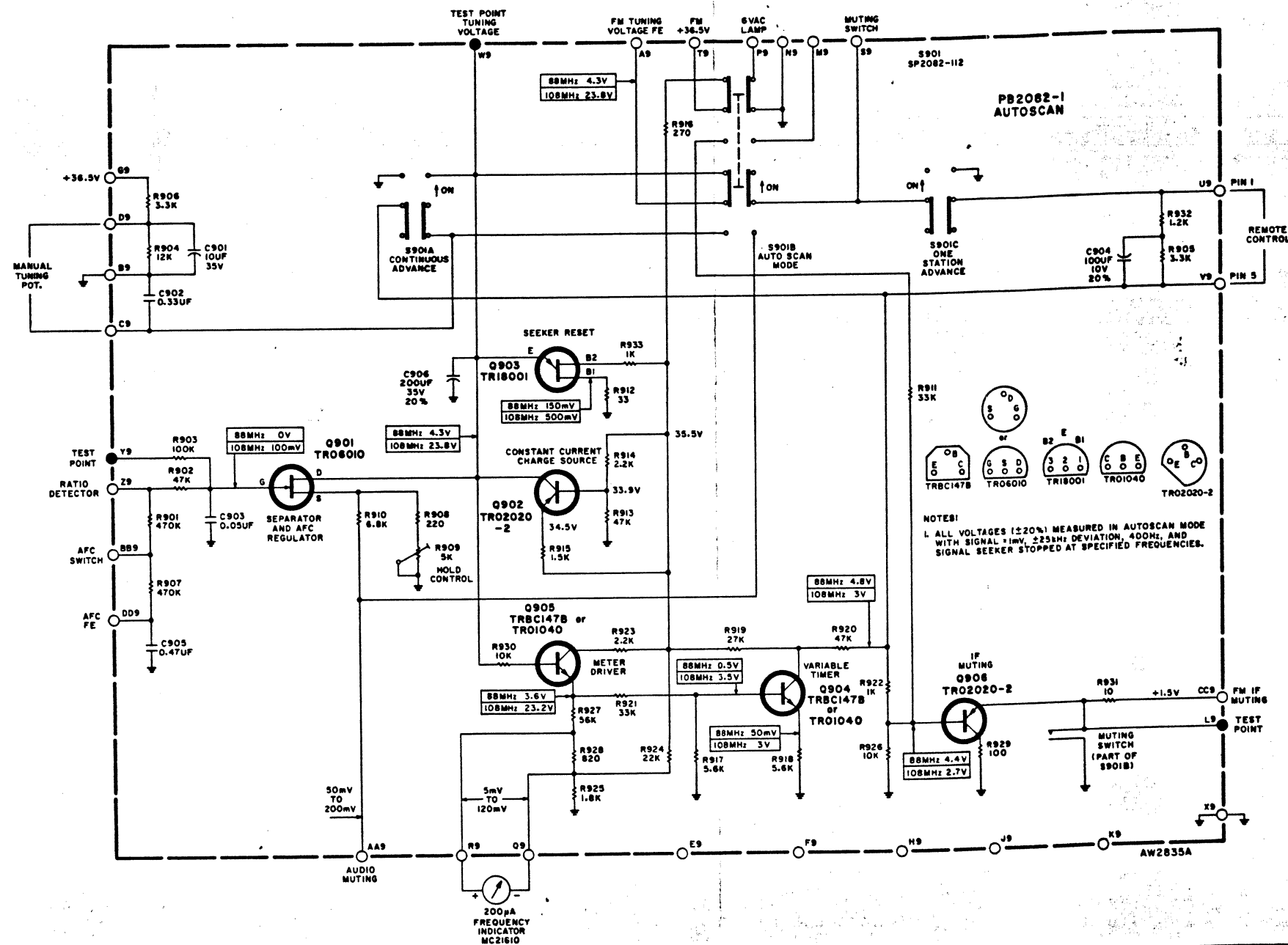

The emitter of IF muting transistor Q906 is DC-coupled to the IF amplifier. When the receiver is tuned on-station, Q906 is reverse-biased, and operation of the IF amplifier is unaffected. When either ADVANCE button is pressed, the grounding of C904 momentarily drops the base voltage and forward-biases Q906, shorting the IF amplifier. The drop in IF signal level releases the hold on the tuning voltage across C904 and the receiver begins to scan. As the voltage on C904 rises, Q906 resumes reverse-bias operation and the IF amplifier becomes operative. The release time (the time during which the IF is muted by Q906) must be sufficiently long to allow the receiver to tune off-station, but short enough to prevent station skipping.

To sweep the receiver 1MHz requires a change in tuning voltage of approximately 1/2 volt at 88MHz, and approximately 1 1/2 volts at 108MHz. Therefore, tuning time varies about 1:3 between 88MHz and 108MHz. The corresponding release time at 108MHz must be three

times longer than at 88MHz. Variable timer transistor Q904 progressively loads the base of Q906 to lower the voltage applied to C904, and lengthen the release time at 108MHz.

To eliminate switch noise, the IF is momentarily shorted by the muting switch whenever the AUTOSCAN MODE switch is actuated.

### ADJUSTMENT AND TEST

Alignment of FM IF and RF, MPX, and detector should be checked before attempting an AUTOSCAN test or adjustment.

(1) Connect an FM signal generator to FM ANTenna terminals through 120-ohm composition resistors, one in a series with each lead from the generator. Connect a DC VTVM to pin 9Y, and a scope to LEFT RCDR 1 OUT jack.

- (2) Set SELECTOR to FM. Turn VOLUME to minimum. Depress AFC OFF switch. Depress AUTOSCAN MODE switch (electronic tuning).
- (3) Set generator frequency to 88MHz. Modulate generator with 400Hz,  $\pm 25$ kHz deviation. Set generator output to 10mV.
- (4) Tune receiver to generator frequency (at 88MHz) by pressing either ADVANCE pushbutton.
- (5) Carefully adjust HOLD CONTROL R909 for 0 VDC. Use lowest (most sensitive) meter scale.
- (6) Reduce generator output to 100uV. Press and hold CONTINUOUS ADVANCE pushbutton until AUTOSCAN meter approaches top of scale. Receiver should automatically tune to generator frequency at 88MHz. After 5 seconds, DC VTVM should indicate 0 VDC.
- (7) Set generator frequency to 108MHz. Tune receiver to generator frequency (at 108MHz) by pressing either ADVANCE pushbutton. After 5 seconds, meter should indicate less than 200mV.

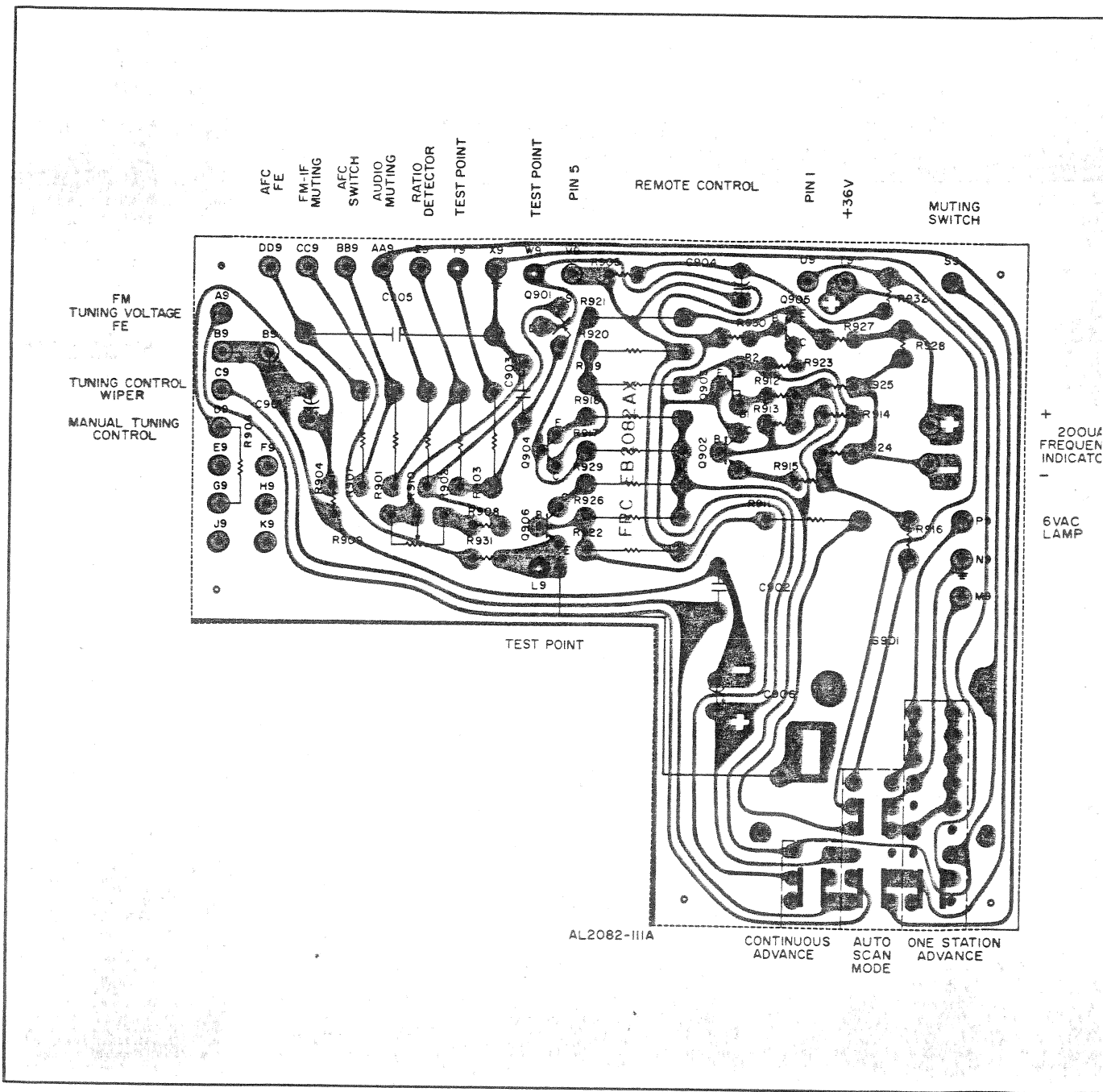

### CIRCUIT DESCRIPTION

The FM RF circuitry utilizes variable capacitance diodes, called varactors. When reverse-biased, these diodes exhibit a change in capacity as the reverse-bias voltage is changed (i.e. increasing voltage decreases capacity). The front-end, therefore, is tuned by an applied DC 'tuning' voltage instead of a mechanical tuning gang. The AUTOSCAN circuit generates and controls this required tuning voltage.

Transistor Q902 provides a constant-current source to charge storage capacitor C906. As the tuning voltage on C906 rises, the front-end tunes upscale toward 108MHz. When the tuning voltage climbs to approximately +25V (108.5MHz), the emitter peak-point voltage of unijunction transistor Q903 is reached, and C906 is instantly discharged (through Q903) to approximately 3 volts. The moment C906 is discharged, Q903 resumes its normal operating state (essentially open-circuit), and the

charging cycle repeats.

The separator and AFC regulator, field-effect transistor Q901, functions as a variable shunt across the constant current charge source. The gate is DC-coupled to the output of the ratio detector. When the output voltage of the detector sweeps to zero (exact center of station), Q901 loads the charging source to maintain a constant tuning voltage across C906. The hold control adjustment, R909, is used to set the load current equal to the charge current (constant tuning voltage) when the gate voltage is zero. The source of Q901 is DC-coupled to the audio muting circuit. When the receiver is tuned on-station, the muting output voltage is approximately zero. As the receiver tunes off-station, the muting voltage (applied to the source through R910) rises rapidly to +15V, allowing the tuning voltage to rise. When the receiver scans upscale to the next desired station, the muting and detector voltages swing to zero, and Q901 loads Q902 to establish and hold the correct tuning voltage.



PUSHBUTTON-SWITCH BOARDS

SPEAKER SELECTOR 2096 - 1

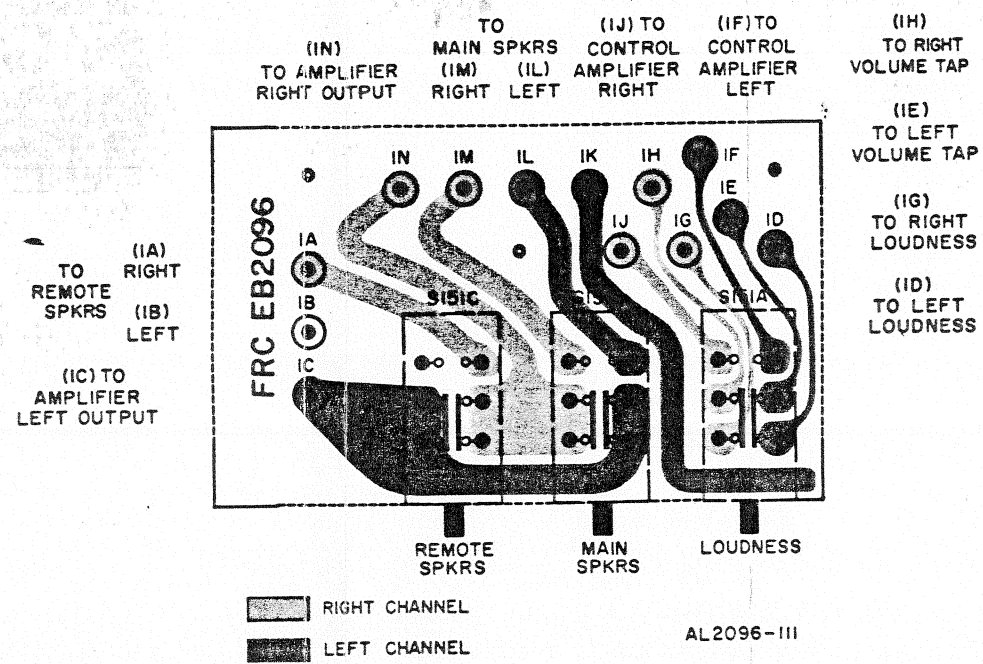

SELECTOR 2099 - 1

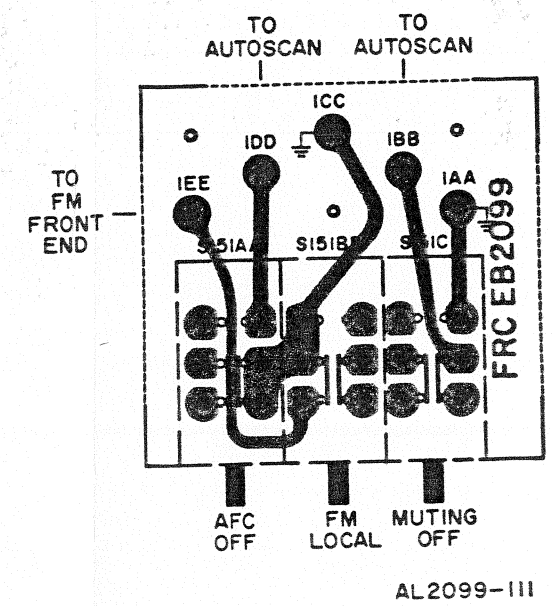

MODE/MONITOR 2201 - 1

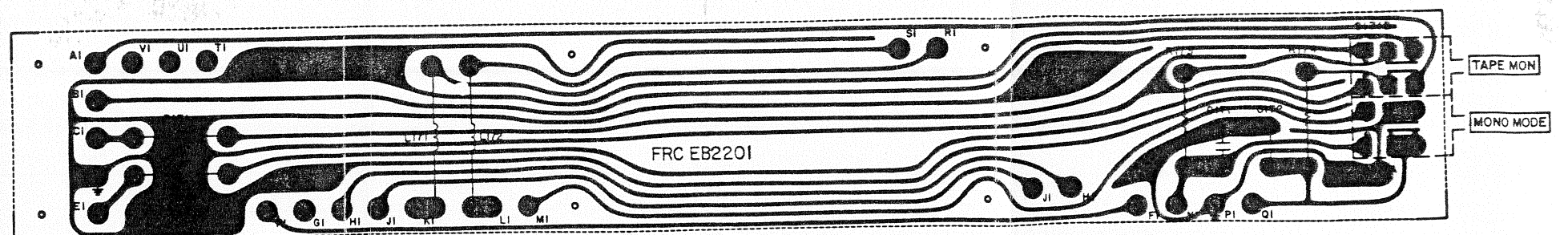
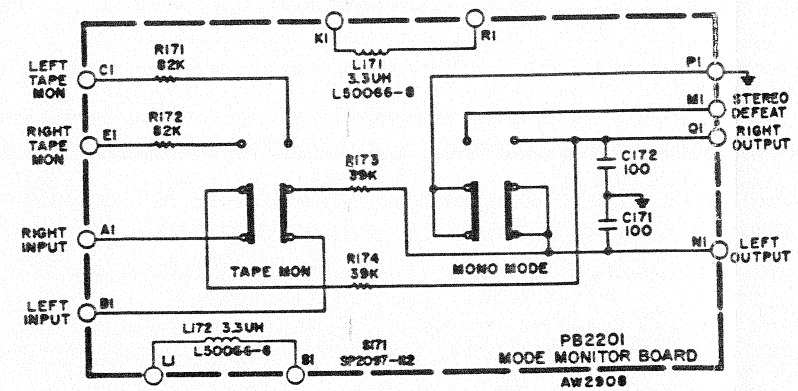

AL2201-IIIIB  
PB2201

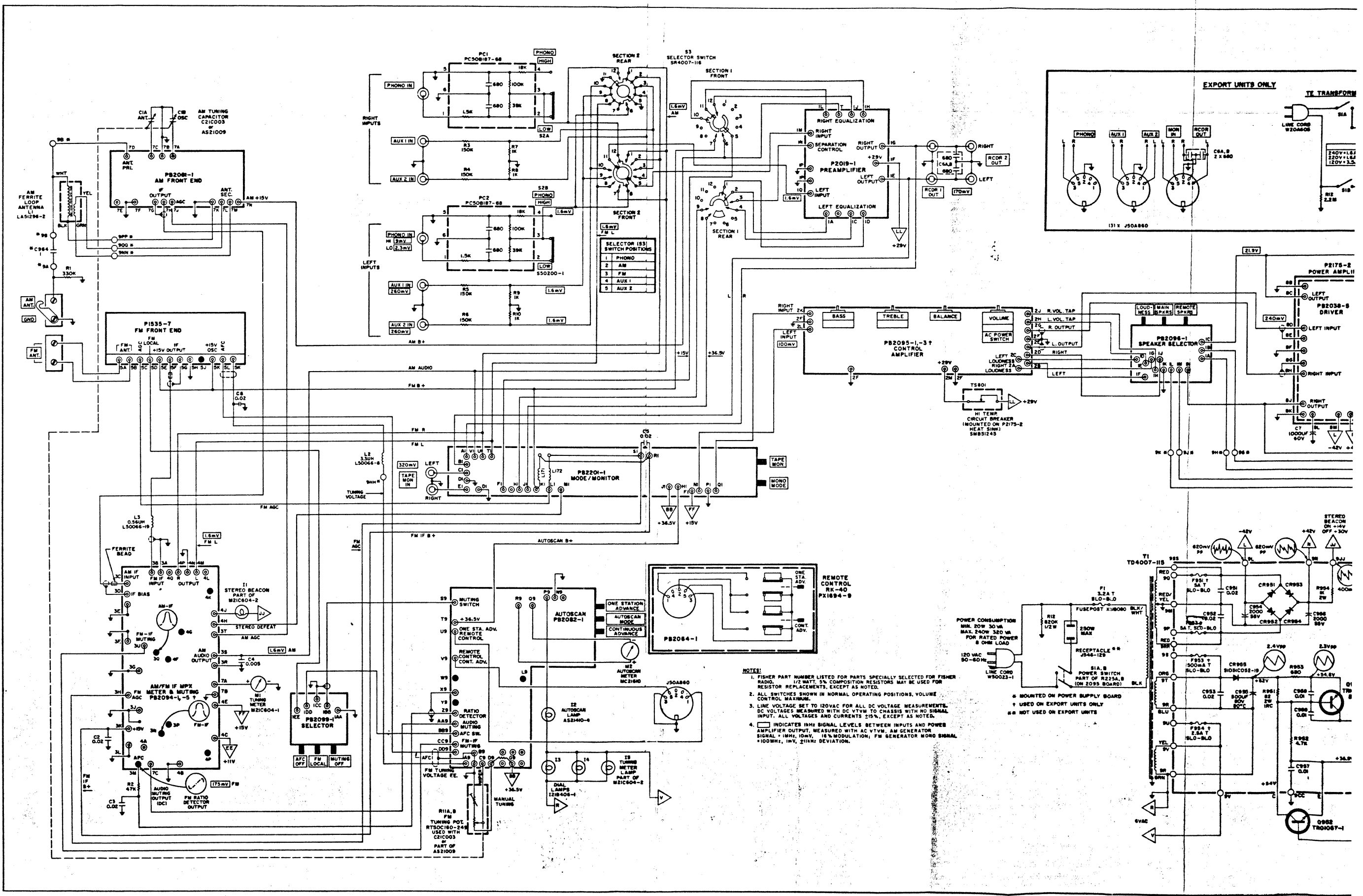

- NOTES:
1. FISHER PART NUMBER LISTED FOR PARTS SPECIALLY SELECTED FOR FISHER RADIO. 1/2 WATT, 5% COMPOSITION RESISTORS MAY BE USED FOR RESISTOR REPLACEMENTS, EXCEPT AS NOTED.
  2. ALL SWITCHES SHOWN IN NORMAL OPERATING POSITIONS, VOLUME CONTROL MAXIMUM.
  3. LINE VOLTAGE SET TO 120VAC FOR ALL DC VOLTAGE MEASUREMENTS. DC VOLTAGES MEASURED WITH DC VTVM TO CHASSIS WITH NO SIGNAL INPUT. ALL VOLTAGES AND CURRENTS 25%, EXCEPT AS NOTED.
  4. INDICATOR INH SIGNAL LEVELS BETWEEN INPUTS AND POWER AMPLIFIER OUTPUT. MEASURED WITH AC VTVM. AM GENERATOR SIGNAL +100%, 100V, 10% MODULATION; FM GENERATOR MONO SIGNAL +100MHz, 10V, 21kHz DEVIATION.

POWER CONSUMPTION  
 MIN. 20W 30VA  
 MAX. 240W 320VA  
 FOR RATED POWER  
 8 OHM LOAD

RECEPTACLE \*\*  
 J546-123

SIA, B  
 POWER SWITCH  
 PART OF R225A, B  
 (ON 2055 BOARD)

\* MOUNTED ON POWER SUPPLY BOARD  
 † USED ON EXPORT UNITS ONLY  
 \*\* NOT USED ON EXPORT UNITS

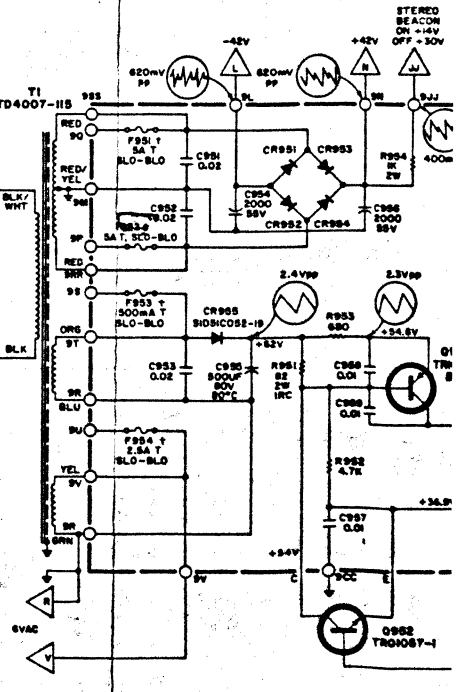
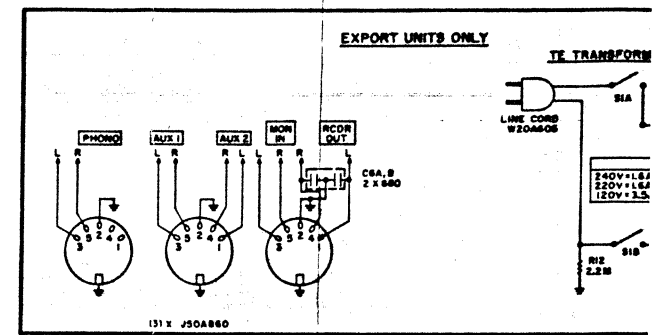

# MAIN CHASSIS

