

THIS MANUAL ALSO COVERS
THE 800-T RECEIVER

N1664-203 A

Service Manual

THE FISHER.

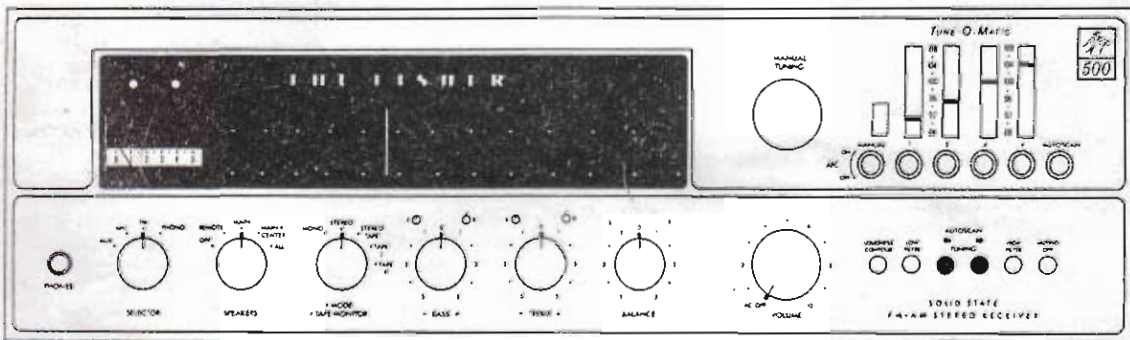

500-TX™

CHASSIS SERIAL NUMBERS
BEGINNING 10001

PRICE \$1.00

FISHER RADIO CORPORATION • 11-40 45th ROAD • LONG ISLAND CITY, N.Y. 11101

REQUIRED TEST EQUIPMENT

The following equipment is required to completely test and align modern high-fidelity amplifiers, tuners, and receivers.

Line Voltage Autotransformer or Voltage Regulator
DC Vacuum Tube Volt ohmmeter
Accurately Calibrated AC Vacuum Tube Voltmeter
Oscilloscope (Flat to 100 kHz Minimum)
Low-Distortion Audio (Sine Wave) Generator
Intermodulation Distortion Analyzer
Harmonic Distortion Analyzer
2 – Load resistors, 8-Ohms, 100 Watt (Minimum Rating)
AM/FM Signal Generator

10.7 MHz Sweep Generator
Multiplex Generator (preferably with RF output – FISHER 300)
455 kHz Sweep Generator
Ferrite Test Loop Stick
2 – Full Range Speakers for Listening Tests
Stereo Source – Turntable, Tape Recorder, etc.
Soldering Iron with Small Tip, Fully Insulated from AC Line
Suction Desoldering Tool

CAUTION: This precision high-fidelity instrument should be serviced only by qualified personnel, trained in the repair of transistor equipment and printed circuitry.

Many of these items are included only as a reminder – they are normal procedures for experienced technicians. Shortcuts may be taken, but these often cause additional damage to transistors, circuit components, or printed circuit boards.

SOLDERING: A well-tinned, hot, clean soldering iron tip will make soldering easier, without causing damage to the printed circuit board or the components mounted on it. Regular use of a sponge cleaner will maintain a clean soldering surface. The heat available at the tip, (not the wattage of the iron) is important. Some 50-watt irons reach temperatures of 1,000° F, while others will hardly melt solder. Small-diameter tips should be used for single solder connections, pyramid and chisel tips for large areas.

Always disconnect the AC power cord from the line when soldering. Turning the power switch OFF is not sufficient. Power-line leakage paths, through the heating element of the iron, may destroy transistors.

PARTS REMOVAL: If a part is not being returned for in-warranty factory replacement, it may be cut in half (with diagonal cutting pliers) to make removal easier. Multiple terminal parts, such as IF transformers, or electrolytic capacitors, should be removed using special de-soldering tips made especially for this purpose. Removing solder from terminals, reduces the possibility of breaking the printed circuit board when the part is removed.

ACCIDENTAL SHORTS: A clean working area, free of metal particles, screws, etc., is an important preventive in avoiding servicing problems. Screws, removed from the chassis during servicing, should be stored in a box until needed. While a set is operating, it takes only an instant for a base-to-collector short to destroy a transistor (and others direct-coupled to it). In the time it takes for a dropped machine screw, washer, or screwdriver, to contact a pair of socket terminals (or terminal and chassis), a transistor can be ruined.

SOLID-STATE DEVICES: Integrated Circuits contain the equivalent of many circuit parts, including transistors, diodes, resistors, and capacitors. The preferred troubleshooting procedure requires isolating the trouble to one stage using AC signal tracing methods. Once the suspected stage is located, the DC voltages at the input and output leads are measured to give an accurate indication of the operating conditions of the IC. DO NOT use an ohmmeter to check continuity with the IC mounted on the printed circuit board. Forward biasing the internal junctions within the IC may burn out the transistors. Do not replace a defective IC until all external resistors, capacitors, and transformers are checked first, to prevent the replacement IC from failing immediately due to a defect in the connecting components. Solder and unsolder each lead separately using a pliers or other heat sink on the lead to prevent damage from excessive heat. Check that the leads are

connected to the correct locations on the printed circuit board before turning the set on.

Whenever possible, a transistor tester should be used to determine the condition of a transistor or diode. Ohmmeter checks do not provide conclusive data, and may even destroy the junction(s) within the device.

Never attempt to repair a transistor power amplifier module until the power supply filter-capacitors are fully discharged.

If an output or driver transistor becomes defective (opens or shorts), always check ALL direct-coupled transistors and diodes in that channel. In addition, check the bias pot., and other parts in the bias network, before installing replacement transistors. All output and driver transistors in one channel may be destroyed if the bias network is defective. After parts replacement, always check the bias adjustment for specified idling current.

In some applications, replacement of transistors must be made from the same beta group as the original type. The beta group is indicated by a colored marking on the transistor. Be sure to include this information when ordering replacement transistors.

When mounting a replacement power transistor, be sure the bottom of the flange, mica insulator, and the surface of the heat sink, are free of foreign matter. Dust and grit will prevent flat contact, reducing heat transfer to the heat sink. Metallic particles can puncture the insulator, cause a short, and destroy the transistor.

Silicone grease must be used between the transistor and the mica insulator, and between the mica and the heat sink, for best heat transfer. Use Dow-Corning DC-3, or an equivalent compound made for power transistor heat conduction.

Use care when making connections to speakers and output terminals. To reduce the possibility of shorts, lugs should be used on the exposed ends, or stranded wire should be tinned to prevent frayed wire ends. Current in the speakers and output circuitry is quite high – poor contacts, or small sized wire, can cause significant power losses in the system. For wire lengths greater than 30 feet, 16 AWG, or heavier, should be used.

VOLTAGE MEASUREMENTS: All voltages are measured with the line voltage adjusted to 120 volts. All measured voltages are $\pm 1\%$. DC voltages are measured to ground with a VTVM, with no signal input unless otherwise noted. AC signal voltages are measured under the conditions specified on the schematic.

ALIGNMENT PROCEDURES: DO NOT attempt realignment unless the required test equipment is available, and the alignment procedure is thoroughly understood.

BECAUSE ITS PRODUCTS ARE SUBJECT TO CONTINUOUS IMPROVEMENT, FISHER RADIO CORPORATION RESERVES THE RIGHT TO MODIFY ANY DESIGN OR SPECIFICATION WITHOUT NOTICE AND WITHOUT INCURRING ANY OBLIGATION.

SERVICE PROCEDURES

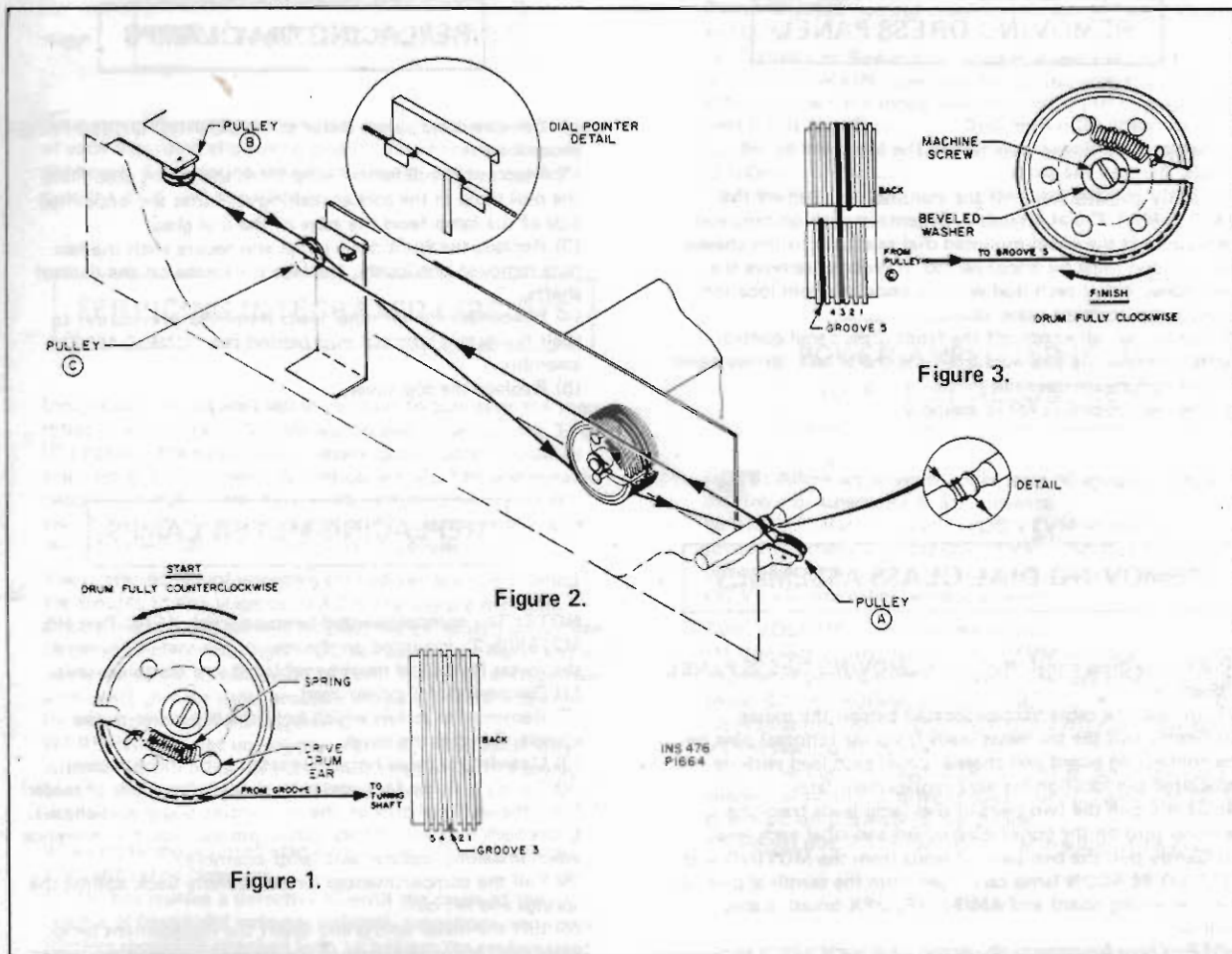

DIAL STRINGING

- (1) Remove dress panel. Refer to REMOVING DRESS PANEL procedure.
- (2) Remove dial pointer.
- (3) Remove dial glass assembly. Refer to REMOVING DIAL GLASS ASSEMBLY procedure.
- (4) Rotate the tuning capacitor drive-drum to its maximum CCW position. Loosen the machine screw in the center of the drive-drum and remove the old dial cord.
- (5) Tie end of new dial cord to one end of dial spring. Fasten spring to bottom right ear inside drive-drum. See Figure 1.
- (6) Run the dial cord through the slot in the rim of the drive-drum and set in the underside of groove 3.
- (7) Pull dial cord taut and wrap 2 turns CCW around tuning shaft. See Figure 2.
- (8) Guide the dial cord under and around pulley "A", across to the left side, around pulley "B", and over pulley "C". Keep dial cord taut during this procedure.
- (9) Rotate the drive-drum to its maximum CW position, allowing the cord to wind onto the drive-drum. Keep the dial cord taut during this procedure.
- (10) Guide the dial cord under the drive-drum and into groove 5. Bring the dial cord around groove 5 and into the slot in the drive-drum. See Figure 3.
- (11) With the machine screw loosened, place the cord under the beveled washer, pull the dial cord taut, and tighten the screw.

- (12) Turn the tuning shaft to rotate the drive-drum fully CCW and fully CW to distribute the tensioning along the dial cord.
- (13) Repeat steps (11) and (12) until dial spring is tensioned.
- (14) Remount the dial glass assembly using the three mounting screws removed previously.
- (15) Place the dial cord over and under the tabs on the rear of the dial pointer (see detail), and place the pointer on the top of the dial glass panel rail.
- (16) Turn the tuning shaft fully CCW. Slide the dial pointer to zero (0) calibration mark on the logging scale while holding tuning shaft fully CCW. Cement dial pointer to dial cord to prevent slippage. Allow cement to thoroughly dry.
- (17) Reinstall the dress panel and knobs. Reconnect all leads (removed previously) to their respective terminals.
- (18) Check dial calibration. Refer to FM FRONT END ALIGNMENT and AM RF ALIGNMENT.
- (19) Remount top cover removed previously.

CLEANING FRONT PANEL

WARNING: Use only plain lukewarm water for moistening a freshly laundered, soft lint-free cloth to clean the front control panel.

SERVICE PROCEDURES

REMOVING DRESS PANEL

- (1) Disconnect AC power cord.
- (2) Remove the screws which hold the top cover to the chassis. Remove the cover.
- (3) Gently pull the leads off the terminal pins behind the TUNE-O-MATIC dial assembly. Seventeen push-on terminal leads connect the panel-mounted dial assembly to the chassis circuitry and must be disconnected in order to remove the dress panel. Label each lead with its associated pin location to make replacement easier later.
- (4) Gently pull all knobs off the front dress panel control shafts. Remove the hex nuts from the shafts and remove panel by pulling forward over the shafts.
- (5) Reverse procedure for reassembly.

REPLACING DIAL LAMPS

- (1) Remove dress panel. Refer to REMOVING DRESS PANEL procedure.
- (2) Snap out the defective lamp from the spring clip. Place the new lamp in the socket making sure that the unpainted side of the lamp faces the edge of the dial glass.
- (3) Replace the front dress panel and secure with the hex nuts removed previously. Replace the knobs on the control shafts.
- (4) Reconnect the terminal leads (removed previously) to their respective terminal pins behind the TUNE-O-MATIC assembly.
- (5) Replace the top cover.

REMOVING DIAL GLASS ASSEMBLY

- (1) Remove dress panel. Refer to REMOVING DRESS PANEL procedure.
 - (2) Untwist the cable harness located behind the meter.
 - (3) Gently pull the six meter leads from the terminal pins on the connecting board and chassis. Label each lead with its associated pin location for easy replacement later.
 - (4) Gently pull the two pairs of dial lamp leads from the terminal pins on the connecting board and label each lead.
 - (5) Gently pull the two pairs of leads from the MUTING and STEREO BEACON lamp cartridges from the terminal pins on the connecting board and AM/FM IF, MPX board. Label each lead.
- NOTE:** These fourteen push-on terminal leads which connect the dial glass panel to the chassis must be disconnected in order to remove the dial glass panel.
- (6) Remove the left dial lamp to expose the screw holding the left side of the dial glass panel.
 - (7) Remove the three screws holding the dial glass panel. Remove the panel with the dial glass, right dial lamp, MUTING lamp, STEREO BEACON lamp, and meter attached by tilting out the bottom of the panel and sliding downward. Be careful to avoid deforming dial pointer.
 - (8) Reverse the procedure for reassembly.

REPLACING METER LAMPS

- NOTE:** The compartmented lamp assembly (FRC Part No. M21B605-2), mounted on the rear of the meter, contains the meter lamps and must be replaced as a complete unit.
- (1) Disconnect AC power cord.
 - (2) Remove the screws which hold the top cover to the chassis. Remove the cover.
 - (3) Untwist the cable harness located behind the meter.
 - (4) Gently pull the four meter lamp leads (top rear of meter) from the terminal pins on the connecting board and chassis. Label each lead with its associated pin location for reference when installing replacement lamp assembly.
 - (5) Pull the compartmented lamp assembly back against the springs and lift out.
 - (6) Lift the meter spring and insert the replacement lamp assembly. Allow the holes in the flange to engage the meter screws.
 - (7) Connect the four leads to the correct pins on the connecting board and chassis.
 - (8) Retwist the cable harness and replace top cover.

REPLACING MUTING OR STEREO BEACON LAMP

- (1) Remove dress panel. Refer to REMOVING DRESS PANEL procedure.
- (2) Remove the four screws holding the dial glass to the dial glass panel. Remove the dial glass.
- (3) Untwist the cable harness located behind the meter.
- (4) Gently pull the pair of leads of the MUTING or STEREO BEACON lamp cartridge from their respective terminal pins. Label each lead with its associated pin location for reference when installing replacement cartridge.
- (5) Remove the defective MUTING or STEREO BEACON lamp cartridge by pulling through dial glass panel.
- (6) Reverse the procedure for reassembly, using the replacement cartridge.

REPLACING METER

- (1) Remove dress panel. Refer to REMOVING DRESS PANEL procedure.
- (2) Remove dial glass assembly. Refer to REMOVING DIAL GLASS ASSEMBLY procedure.
- (3) Pull the compartmented lamp assembly back against the meter spring and lift off. Remove the spring from the panel.
- (4) Gently pry the meter off the dial glass panel, and scrape the residual adhesive from the panel.
- (5) Peel the backing from one side of the replacement adhesive mounting pad (FRC Part No. E51A165), and affix it to the replacement meter. Peel the backing from the remaining side of the adhesive pad, align the meter face over the dial panel cutout, and firmly press the meter to the back of the dial glass panel.
- (6) Remount the meter spring to panel. Lift the meter spring and insert the compartmented lamp assembly. Allow the holes in the flange to engage the meter screws.
- (7) Remount the dial glass assembly.
- (8) Reinstall the dress panel. Reconnect all leads (removed previously) to their respective terminal pins.
- (9) Check meter calibration. Refer to TUNING METER AND MUTING LEVEL ADJUSTMENTS procedure.
- (10) Remount top cover.

SERVICE PROCEDURES

REMOVING P.C. BOARDS

To remove a board from its nylon mounts, squeeze the loop of each mounting clip (using pliers), and lift each corner of the board. To remount the board, align the mounting holes over the clips, and press firmly.

SERVICING INTEGRATED CIRCUITS

Integrated Circuits are used in this unit to approach the theoretical maximum of AM suppression and noise limiting. These IC's contain the equivalent of many circuit parts, including transistors, diodes, resistors, and capacitors. These integrated circuits are high-reliability devices, requiring minimum servicing. In the unlikely event that an IC requires servicing, it should be serviced in the same way as a transistor.

The preferred troubleshooting procedure requires isolating the trouble to one stage using AC signal tracing methods. Once the suspected stage is located, the integrated circuit can be checked by measuring the DC voltages at the input and output leads of the IC using a DC VTVM. These DC voltage measurements give the most accurate indications of the operating conditions of the integrated circuit.

WARNING: Do not use an ohmmeter to check continuity with the IC mounted on the printed circuit board. Forward biasing the internal junctions within the IC may burn out the transistors.

When replacing an integrated circuit, the following precautions should be observed:

- (1) Do not replace a defective IC until the cause of the trouble is found. All external resistors, capacitors, and transformers should be checked first, to prevent the replacement integrated circuit from failing immediately due to a trouble in the connecting components.
- (2) Solder and unsolder each lead separately using a pliers or other heat sink on the lead to prevent damage from excessive heat.
- (3) Check that the leads of the replacement IC are connected to the correct locations on the printed circuit board before turning the set on.

FUSES

EXPORT CHASSIS ONLY:

Additional safety fuses are used in the transformer secondary circuits of this receiver, to provide increased protection. For fuse type and rating, refer to MAIN CHASSIS schematic.

For added safety, the power amplifier module in this receiver is individually fused. For fuse type and rating, refer to POWER AMPLIFIER MODULE schematic.

POWER AMPLIFIER CENTER VOLTAGE TEST

NOTE: Allow set to warm up at least 30 minutes before making measurements or adjustments.

Turn VOLUME control to minimum. Set SPEAKERS switch to MAIN.

- (1) Connect an 8-ohm load resistor across the LEFT SPEAKERS MAIN terminals. In parallel with the load resistor, connect the input leads of a DC VTVM. Meter should read 0 volt ($\pm 100\text{mV}$).
- (2) Remove the 8-ohm load resistor. Meter should read 0 volt ($\pm 100\text{mV}$).
- (3) Repeat the preceding steps for right channel.

POWER AMPLIFIER IDLING CURRENT ADJUSTMENT

NOTE: Allow set to warm up at least 30 minutes before making measurements or adjustments.

WARNING: Before using the DC VTVM in the following procedure, make sure the DC VTVM is isolated from the power line, and there is no ground connection between the DC VTVM and other test equipment.

Turn VOLUME control to minimum.

- (1) Connect ground lead of DC VTVM to pin 8C on left channel of predriver/driver board. Connect probe of DC VTVM to pin 8Z on predriver/driver board.
- (2) Adjust pot. R815 (OUTPUT BIAS ADJUST) for DC VTVM reading of 15 mV.
- (3) Connect ground lead of DC VTVM to pin 8J on right channel of predriver/driver board. Connect probe of DC VTVM to pin 8Q on predriver/driver board.
- (4) Adjust pot. R816 for DC VTVM reading of 15 mV.

POWER OUTPUT MEASUREMENT

The output amplifier of this unit is designed to deliver its full-rated power with program material (voice or music) into 8-ohm loads for an indefinite period of time. When a constant audio tone is used as a signal to measure the maximum continuous RMS power output, the following precautions must be taken:

- (1) Measure the power output of one channel at a time.
- (2) Limit the measurement period to 10 minutes with a load resistance of 8 ohms.
- (3) Use a load resistor with a power rating of at least 100 watts.

WARNING: If the power output of both channels is measured simultaneously, use a load of 8 ohms per channel and limit measurements to a period not longer than 5 minutes.

NOTE: This unit uses a high temperature cutout switch to protect the amplifier against damage resulting from overheating. The switch disables the amplifier by eliminating drive signal in the audio control amplifier. When the amplifier cools to normal operating temperature, the cutout switch automatically resets.

HARMONIC DISTORTION TEST

Set SELECTOR switch to AUX, SPEAKERS switch to MAIN, and MODE/TAPE MONITOR switch to STEREO. Set

SERVICE PROCEDURES

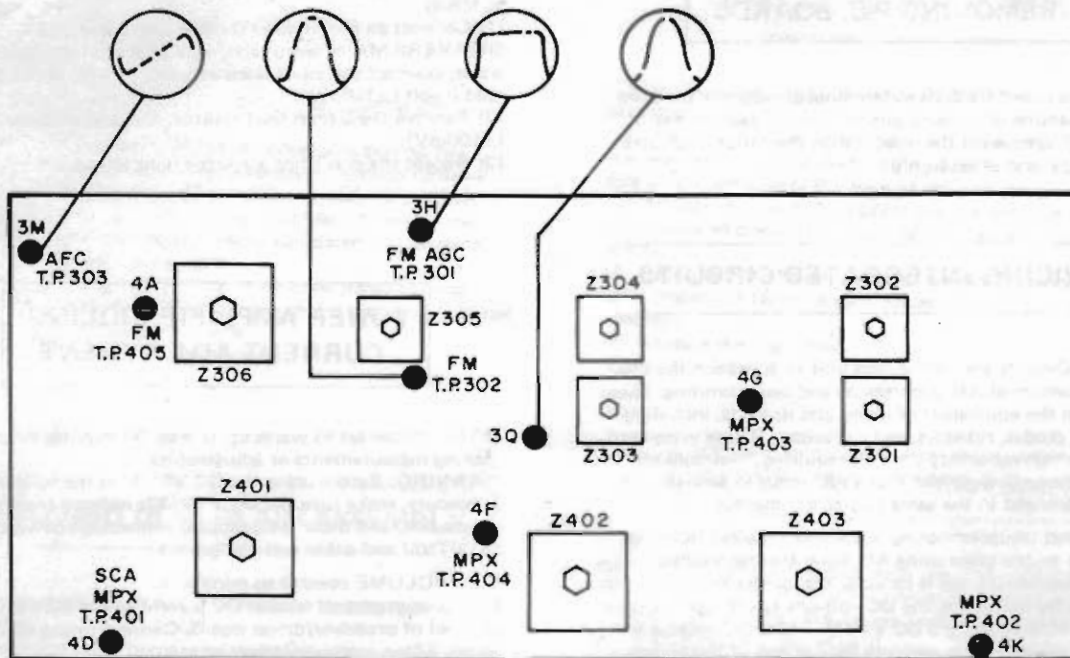

Figure 4. AM-FM IF, MPX, Meter, Muting Board Alignment Location.

BASS, TREBLE, and BALANCE controls to their center (flat) positions.

- (1) Connect an 8-ohm, 100-watt resistor across the LEFT SPEAKERS MAIN terminals. In parallel with the load resistor, connect the input leads of an accurately calibrated AC VTVM.
- (2) Connect a low-distortion audio sine-wave generator, set for 1,000 Hz, to the LEFT AUX IN jack.
- (3) Rotate VOLUME control to maximum.
- (4) Increase audio generator level for 60 watts output (21.9 V RMS across 8-ohm load). HD meter should read 0.5% or less.
- (5) Repeat preceding steps for right channel.

INTERMODULATION DISTORTION TEST

Set SELECTOR switch to AUX, SPEAKERS switch to MAIN, and MODE/TAPE MONITOR switch to STEREO. Set BASS, TREBLE, and BALANCE controls to their center (flat) positions.

- (1) Connect an 8-ohm, 100-watt resistor across the LEFT SPEAKERS MAIN terminals. In parallel with the load resistor, connect the input leads of an IM analyzer and the input leads of an accurately calibrated AC VTVM.
- (2) Connect IM-analyzer generator output to the LEFT AUX IN jack.
- (3) Rotate VOLUME control to maximum.
- (4) Increase IM-analyzer generator output for 60 watts output (17.9 V RMS across 8-ohm load). IM meter reading should be 0.8% or less.
- (5) Repeat preceding steps for right channel.

NOTE: If any of the preceding instructions differ from those in the IM-analyzer instruction manual, it is best to follow

those in the manual. If a load resistor of 100-watt (or higher) rating is built into the IM analyzer, a separate load resistor is not required.

FM IF AND DETECTOR ALIGNMENT

Depress MANUAL pushbutton, and turn AFC switch to OFF. Set MANUAL TUNING dial pointer to zero (0) calibration mark on the logging scale. Depress MUTING OFF pushbutton switch. Set SELECTOR switch to FM, and turn VOLUME control to minimum.

- (1) Disconnect capacitor C4 (0.02 μ F) and wire lead from Test Point 301 (pin 3H on AM/FM IF, MPX board). Connect scope vertical input to Test Point 301 (pin 3H). Connect scope ground lead to pin 3G.
- (2) Connect 10.7 MHz sweep generator to Test Point 751 (pin 7G on FM Front End board). Connect ground lead of generator to pin 7F. Set generator output level to approximately 10 mV output and adjust sweep to observe IF response curve.
- (3) Carefully adjust C775 and C780 (on FM Front End board) for maximum gain and symmetry (see Figure 5). Cover trimmer holes with tape after alignment.
- (4) Carefully adjust top core of IF transformer Z302 (on AM/FM IF, MPX board) for maximum gain and symmetry. Carefully adjust bottom core for symmetry and minimum amplitude.
- (5) Disconnect scope connections. Reconnect capacitor C4 and wire lead to Test Point 301 (pin 3H on AM/FM IF, MPX board) removed previously.
- (6) Connect scope vertical input to Test Point 302 (tip of resistor R332, 180k, on AM/FM IF, MPX board). Carefully adjust core of IF transformer Z305 for maximum gain and

SERVICE PROCEDURES

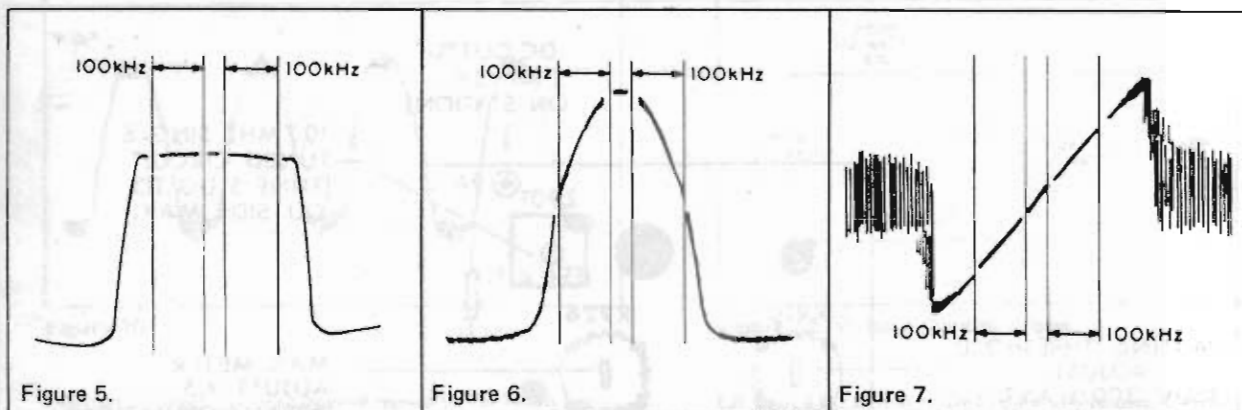

symmetry. Carefully adjust top and bottom core of Z304 for maximum gain and symmetry (see Figure 6). DO NOT READJUST Z302.

(7) Connect scope vertical input to Test Point 303 (pin 3M on AM/FM IF, MPX board). Adjust generator level and sweep to observe detector "S" curve. Adjust bottom core of Z306 first, then top core for maximum gain and symmetry (see Figure 7). Reduce generator sweep to zero (sweep off).

(8) Connect DC VTVM to Test Point 303 (pin 3M). Use most sensitive meter scale setting.

(9) Slightly readjust top core of Z306 for zero (0) reading (within ± 0.1 volt) on DC VTVM.

(9) Repeat alignment procedure at 90MHz and 106MHz until maximum gain is obtained and dial calibration is correct.

FM FRONT END ALIGNMENT

Depress MANUAL pushbutton, and turn AFC switch to OFF. Depress MUTING OFF pushbutton switch. Set SELECTOR switch to FM, and MODE/TAPE MONITOR switch to MONO. Turn VOLUME control to minimum.

(1) Set MANUAL TUNING dial pointer to zero (0) calibration mark on the logging scale. If the dial pointer is not centered on the (0) at the extreme end of knob rotation, reposition the pointer assembly on the dial cord and cement the pointer in place to prevent slippage. Allow cement to thoroughly dry.

NOTE: Repositioning dial pointer may require realignment of AM RF board for correct AM station calibration.

(2) Connect an accurately calibrated DC VTVM to Test Point 701 (pin 7M on Muting board).

(3) Set dial pointer to 2.3 on logging scale. Adjust R4 MANUAL TUNING pot. (fine adjustment) for 5.63V indication on DC VTVM. Disconnect DC VTVM from Test Point 701 (pin 7M).

(4) Connect an FM generator to the FM ANTenna terminals. Use a 120-ohm composition resistor in series with each lead from the generator (see Figure 8).

(5) Connect a scope and an AC VTVM to either the LEFT or RIGHT RCDR OUT jack.

(6) Modulate FM generator with 400Hz, ± 75 kHz deviation. Set generator frequency to 90MHz. During alignment, adjust generator output as low as possible.

(7) Align (oscillator coil) L754 first, then (RF transformers) L753, and L752, and (antenna coil) L751 for maximum indication on AC VTVM and oscilloscope.

(8) Set generator frequency and dial pointer to 106MHz. Align (oscillator trimmer) C769 first, then (RF trimmers) C768, and C763, and (antenna trimmer) C754 for maximum indication on AC VTVM and oscilloscope.

TUNING METER AND MUTING LEVEL ADJUSTMENTS

NOTE: These adjustments should be performed after FM IF and RF alignment.

Depress MANUAL pushbutton, and turn AFC switch to OFF. Depress MUTING OFF pushbutton switch. Set SELECTOR switch to FM, and MODE/TAPE MONITOR switch to MONO. Turn VOLUME control to minimum.

(1) Connect an FM generator to the FM ANTenna terminals. Use a 120-ohm composition resistor in series with each lead from the generator (see Figure 8).

(2) Set MANUAL TUNING dial pointer to zero (0) calibration mark on logging scale. Set FM generator frequency to receiver frequency.

(3) Connect a scope and an AC VTVM to either the LEFT or RIGHT RCDR OUT jack.

(4) Modulate FM generator with 400 Hz, ± 75 kHz deviation.

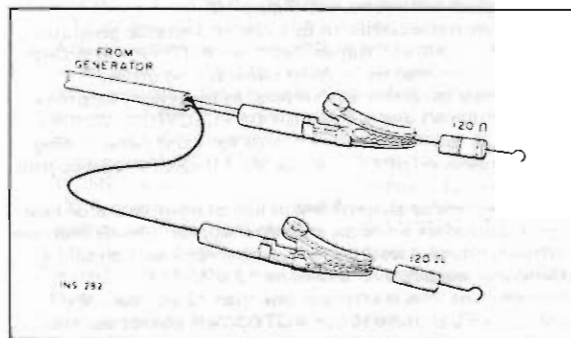

Figure 8. Connections To Provide 300-ohm Generator Output Impedance. Matching Resistors Reduce Generator Voltage By Half At Antenna Terminals.

SERVICE PROCEDURES

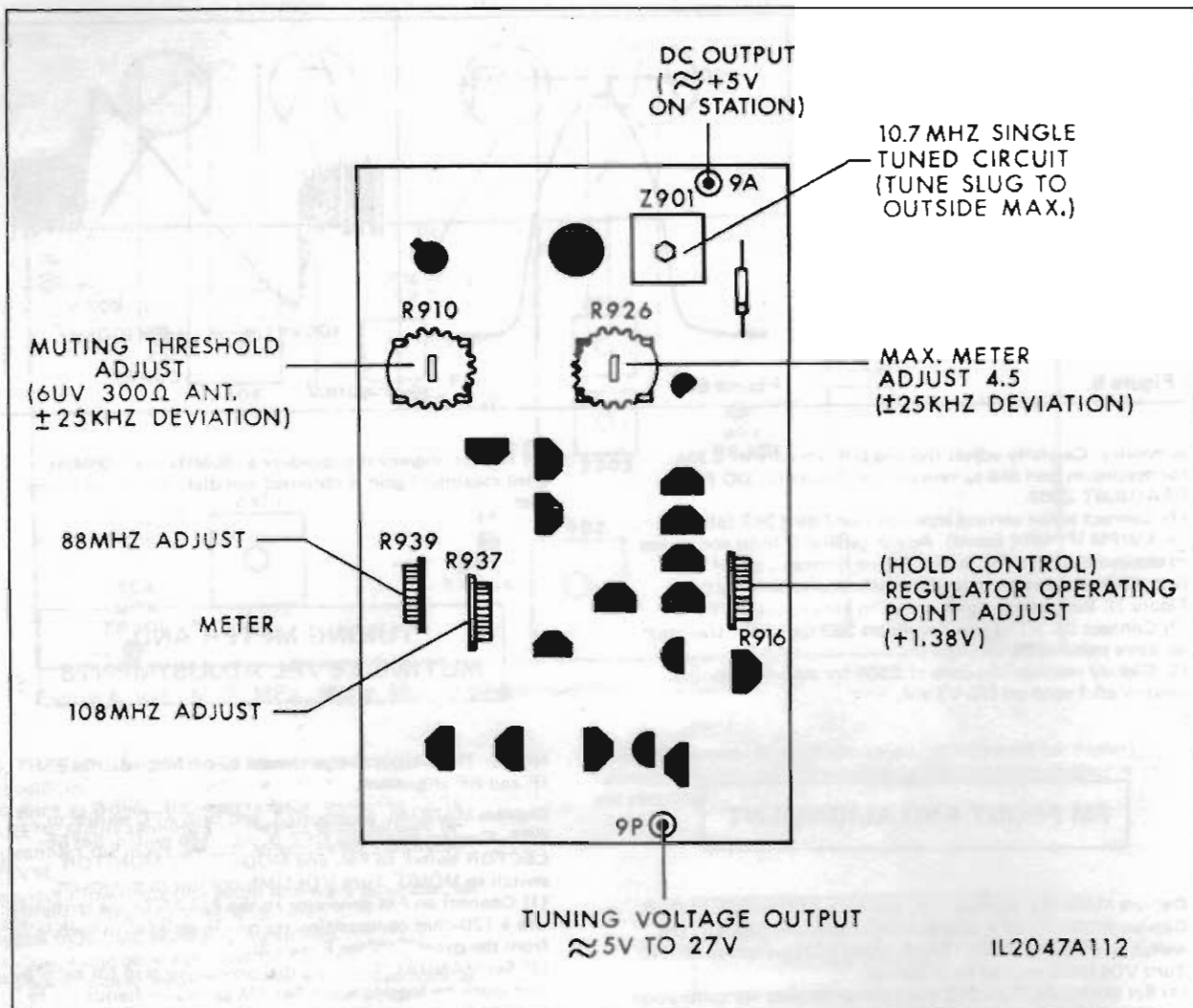

Figure 9. AUTOSCAN Board Alignment Location.

Set generator output to very low level (approximately 5 μ V) until noise interference is visible on sine wave. Adjust generator frequency to center noise interference on the positive and negative half cycles. See Figure 10.

(5) Set generator deviation to ± 25 kHz. Increase generator output to 1,000 μ V. Adjust Z901 (on AUTOSCAN board) for maximum reading on front panel tuning meter.

(6) Increase generator output level to maximum (approximately 100mV) and set METER DEFLECTION ADJUST pot. R926 (on AUTOSCAN board) for front panel tuning meter indication of 4.5. Release MUTING OFF pushbutton switch to out position.

(7) Set generator output level as low as possible (to or near zero). Sine wave on scope should disappear. Slowly increase generator output level until sine wave reappears on scope. Generator output level should be 12 μ V.

(8A) If output level setting is less than 12 μ V, turn MUTING LEVEL pot. R910 (on AUTOSCAN board) counter-clockwise until signal disappears on scope, then set generator level to 12 μ V and turn R910 slowly clockwise until signal reappears.

(8B) If output level setting is more than 12 μ V, set output

level to 12 μ V and turn R910 clockwise until signal reappears on scope.

(9) Repeat step (7) to check adjustment.

AUTOSCAN ADJUSTMENTS

Depress AUTOSCAN pushbutton. Set SELECTOR switch to FM, and turn VOLUME control to minimum. Depress MUTING OFF pushbutton.

(1) Connect DC VTVM to pin 9P (on AUTOSCAN board).
 (2) Press in and hold the right (upscale) AUTOSCAN TUNING pushbutton until pointer of frequency indicator moves to maximum position. DC VTVM should read +24V to +27V. Set 108 MHz ADJUST pot. R937 (on AUTOSCAN board) to center pointer on 108.

(3) Press in and hold the left (downscale) AUTOSCAN

SERVICE PROCEDURES

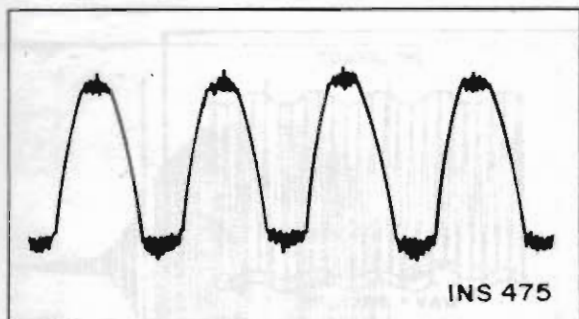

Figure 10.

TUNING pushbutton until pointer moves to minimum position. DC VTVM should read +3.5V to 5.5V. Set 88 MHz ADJUST pot. R939 (on AUTOSCAN board) to center pointer on zero (0) calibration mark (on 0-5 scale).

(4) Connect scope vertical input to either LEFT or RIGHT RCDR OUT jack. Disconnect DC VTVM from pin 9P and reconnect to pin 9V. Connect a second DC VTVM to pin 9A (on AUTOSCAN board).

(5) Connect an FM generator to the FM ANTenna terminals. Use a 120-ohm composition resistor in series with each lead from the generator (see Figure 8). Modulate generator with 400 Hz, ± 75 kHz deviation. Set generator frequency to 88 MHz, and output level to 1,000 μ V.

(6) Press in right (upscale) AUTOSCAN TUNING pushbutton momentarily (release immediately after pushing in). AUTOSCAN circuit should tune receiver to FM generator signal and sine wave should appear on scope.

(7) Carefully adjust HOLD CONTROL pot. R916 (on AUTOSCAN board) for maximum reading on second DC VTVM (+3.5V to 4.5V on pin 9A). Note that first DC VTVM should indicate 0 volt on pin 9V when second DC VTVM indicates maximum voltage on pin 9A. Signal trace on scope should be clean sine wave.

(8) Reduce FM signal generator output level to 15 μ V. Sine wave on scope should remain locked in.

(9) Press in left (downscale) AUTOSCAN TUNING pushbutton momentarily, to make signal disappear. Press in right (upscale) pushbutton momentarily. AUTOSCAN circuit should retune receiver to FM generator signal and sine wave should reappear on scope.

(10) Set FM signal generator frequency to 108 MHz, and output level to 1,000 μ V. Press in right (upscale) pushbutton until AUTOSCAN circuit tunes to generator frequency. Repeat steps (8) and (9).

AFC TEST

NOTE: FM IF, Detector, and Front End Alignment should be checked before starting this procedure.

Depress MANUAL pushbutton, and turn AFC switch to OFF. Depress MUTING OFF pushbutton switch. Set SELECTOR switch to FM, and MODE/TAPE MONITOR switch to MONO.

- (1) Set MANUAL TUNING dial pointer to strong local station, for tuning meter reading of approximately 4.5.
- (2) Detune slowly, downscale, until tuning meter indicates 2.5. Turn AFC switch to ON. Tuning meter should indicate between 4 and 5.

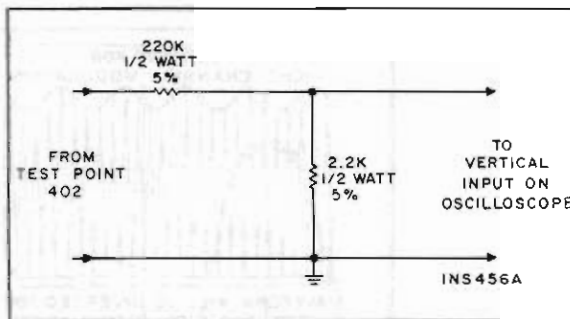

Figure 11. Voltage Divider Probe.

(3) Turn AFC switch to OFF. Carefully retune to station. Detune slowly, upscale, until tuning meter indicates 2.5. Turn AFC switch to ON. Tuning meter should indicate between 4 and 5.

MULTIPLEX ALIGNMENT

Two methods of aligning the multiplex decoder are given. The preferred procedure uses a multiplex generator with RF and 19 kHz outputs and with 1 kHz modulation, such as the FISHER 300 Multiplex Generator. This is the better method of alignment because the front end and IF stages are also checked through the use of this procedure. An alternate procedure for use with multiplex generators not having an RF output is also given.

PREFERRED ALIGNMENT PROCEDURE

NOTE: Check the alignment of the IF amplifier before aligning the multiplex decoder. Poor IF alignment can make proper MPX adjustment impossible.

Depress MANUAL pushbutton, and turn AFC switch to OFF. Depress MUTING OFF pushbutton switch. Set SELECTOR switch to FM, and MODE/TAPE MONITOR switch to STEREO. Turn VOLUME control to minimum.

- (1) Connect RF output of multiplex generator to the FM ANTenna terminals. Use a 120-ohm composition resistor in series with each lead from the RF output (see Figure 8). Set MPX generator for external modulation with 19 kHz pilot carrier, ± 7.5 kHz deviation (10% pilot, no audio). Tune receiver to RF frequency of MPX generator.
- (2) Connect DC VTVM to Test Point 403 (pin 4G on AM/FM IF, MPX board).
- (3) Adjust cores of Z401 and Z402 (on AM/FM IF, MPX board) for maximum reading on DC VTVM.
- (4) Connect output of audio generator, set for 1 kHz, to the external modulation input of MPX generator and to external sync input of an oscilloscope. Adjust audio generator level for composite signal ± 75 kHz deviation (10% pilot, 90% audio).
- (5) Connect AC VTVM to LEFT RCDR OUT jack. Connect scope through voltage divider probe (see Figure 11) to Test Point 402 (4K on AM/FM IF, MPX board).

SERVICE PROCEDURES

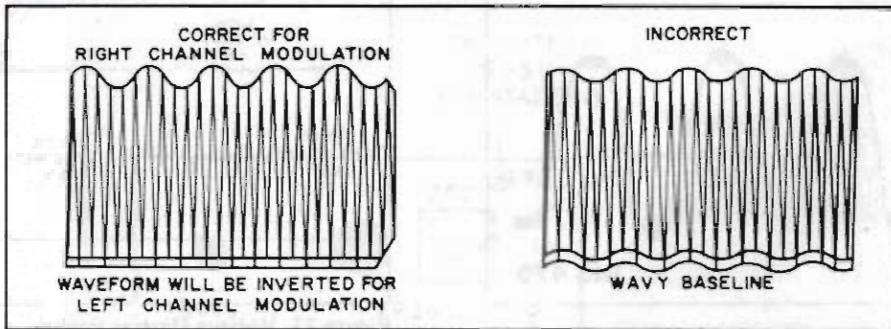

Figure 12. Waveform At Test Point 402

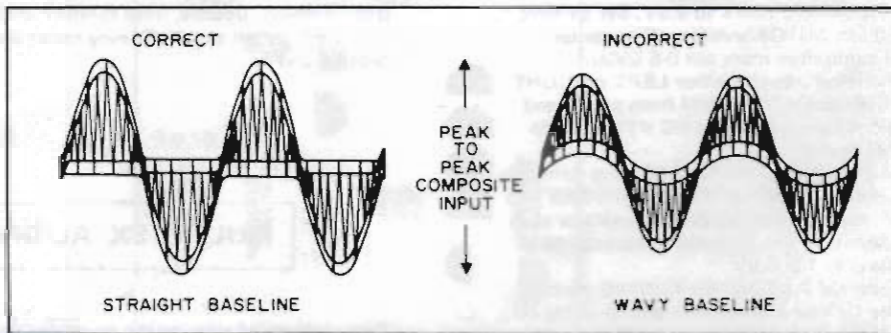

Figure 13. Composite Input To Multiplex Decoder

(6) Set R107 SEPARATION CONTROL (on preamplifier board) to mechanical center. Adjust core of Z403 (on AM/FM IF, MPX board) for maximum gain and as straight a base-line as possible on scope (see Figure 12). AC VTVM should read minimum.

(7) With MPX generator modulated on right channel only, connect AC VTVM to RIGHT RCDR OUT jack. Record reading on AC VTVM.

(8) Set MPX generator to modulate left channel only. Adjust R107 SEPARATION CONTROL (on preamplifier board) for minimum reading on AC VTVM; at least 35 dB below reading recorded in step (7). Record reading.

(9) Connect AC VTVM to LEFT RCDR OUT jack. Same reading ± 2 dB as recorded in step (7).

(10) Set MPX generator to modulate right channel only. Same reading ± 3 dB as recorded in step (8).

NOTE: If equal readings cannot be obtained in steps (8) and

(10) Readjust Z402 slightly (on AM/FM IF, MPX board) and repeat steps (7) through (10).

Adjust pilot level for approximately 120 mV peak-to-peak input at pin 4A.

(4) Adjust cores of Z401 and Z402 (on AM/FM IF, MPX board) for maximum reading on DC VTVM.

(5) Connect output of audio generator, set for 1 kHz, to the external modulation input of MPX generator and to the external sync input of an oscilloscope. Adjust audio generator level for 1.2 volts peak-to-peak composite MPX input (10% pilot, 90% audio). See Figure 13. Modulate right channel only. Proceed with steps (5) through (10) of PREFERRED ALIGNMENT PROCEDURE.

(6) Reconnect the jumper lead going to pin 4A (on AM/FM IF, MPX board) removed previously.

ALTERNATE ALIGNMENT PROCEDURE

Set SELECTOR switch to FM, and MODE/TAPE MONITOR switch to STEREO. Turn VOLUME control to minimum.

(1) Disconnect the jumper lead going to pin 4A (on AM/FM IF, MPX board) and connect the output of the multiplex generator through a 15k resistor to pin 4A.

(2) Connect DC VTVM to Test Point 403 (pin 4G on AM/FM IF, MPX board). Connect the vertical input of the scope to pin 4A.

(3) Set MPX generator for 19 kHz pilot carrier output only.

AM IF ALIGNMENT

Set SELECTOR switch to AM, and MODE/TAPE MONITOR switch to MONO. Turn VOLUME control to minimum.

(1) Connect 455 kHz sweep generator to Test Point 502 (pin 5N on AM RF board). Use a 0.1 μ F capacitor in series with the generator lead. Connect generator ground to pin 5C.

(2) Connect vertical input of scope to Test Point 503 (pin 5R on AM RF board). Connect scope ground to pin 5J.

(3) Temporarily disconnect IF output lead from pin 5K.

Adjust generator level and sweep to observe IF response curve. Set generator output as low as possible.

(4) Align top and bottom cores of Z503 (on AM RF board) for maximum gain and symmetry (see Figure 14). Reconnect

Figure 13

IF output
(5) Discor
Connect s
IF, MPX
(8) Align
IF, MPX
ure 15).

NOTE: A
starting t
Set SELE
switch to
(1) Set M
tion mark
coincide
position
the point
through
NOTE: F
ment of
(1) Open
minim. C
GND ter
(2) Core
or Right
(4) Set A
pointer t
generator
(5) Align
reading t
symmetr
(6) Set A
pointer t
RF board
imum wa
(7) Repe
symmetr
ible dur

SERVICE PROCEDURES

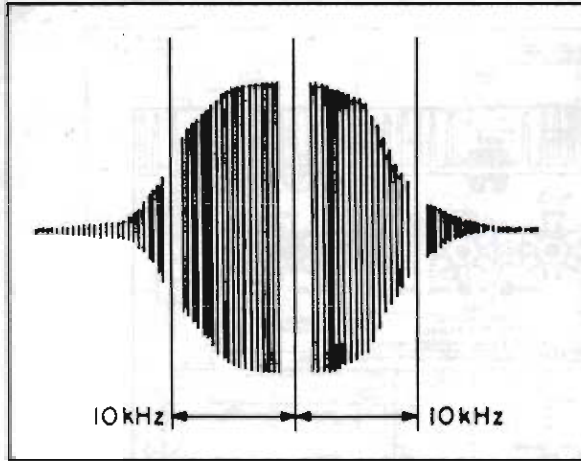

Figure 14.

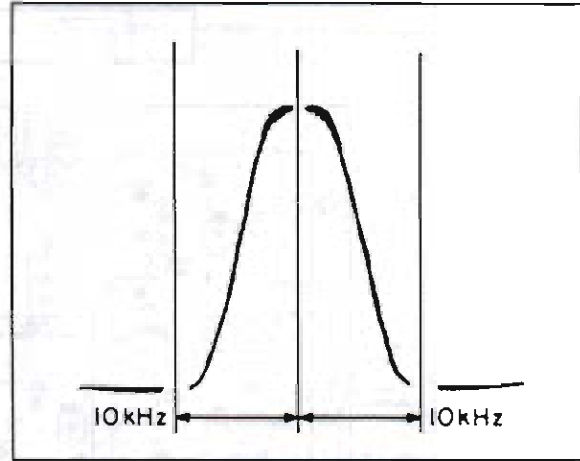

Figure 15.

- IF output lead to pin 5K (removed previously).
- (5) Disconnect scope input and ground from AM RF board. Connect scope input to Test Point 306 (pin 3Q on AM/FM IF, MPX board). Connect scope ground to pin 3R.
- (6) Align top and bottom cores of Z301 and Z303 (on AM/FM IF, MPX board) for maximum gain and symmetry (see Figure 15).

AM RF ALIGNMENT

NOTE: AM IF alignment should be performed before starting this procedure.

Set SELECTOR switch to AM, and MODE/TAPE MONITOR switch to MONO. Turn VOLUME control to minimum.

- (1) Set MANUAL TUNING dial pointer to zero (0) calibration mark on the logging scale. If the dial pointer does not coincide with the 0 at the extreme end of knob rotation, reposition the pointer assembly on the dial cord and cement the pointer in place to prevent slippage. Allow cement to thoroughly dry.

NOTE: Repositioning the dial pointer may require realignment of FM RF board for correct FM station calibration.

- (1) Open the AM ANTenna GND link at the antenna terminals. Connect an AM generator to the AM ANTenna and GND terminals.
- (3) Connect a scope and an AC VTVM to either the LEFT or RIGHT RCDR OUT jack.
- (4) Set AM generator frequency and MANUAL TUNING dial pointer to 600 kHz. Use 30% modulation with 400 Hz. Set generator output as low as possible.
- (5) Align oscillator coil Z502 (on AM RF board) for maximum reading on AC VTVM and maximum waveform amplitude and symmetry.
- (6) Set AM generator frequency and MANUAL TUNING dial pointer to 1400 kHz. Adjust oscillator trimmer C535 (on AM RF board) for maximum reading on AC VTVM and maximum waveform amplitude and symmetry.
- (7) Repeat alignment several times until maximum gain and symmetry are obtained. Keep generator output as low as possible during all adjustments.

- (8) Reset AM generator frequency and MANUAL TUNING dial pointer to 600 kHz. Align mixer coil Z501 and RF coil L501 for maximum reading on AC VTVM, and clean sine wave on scope.
- (9) Reset AM generator frequency and MANUAL TUNING dial pointer to 1400 kHz. Adjust mixer trimmer C534, and antenna trimmer C533 for maximum audio indication on AC VTVM and clean sine wave on scope.
- (10) Repeat steps (8) and (9) several times until maximum gain is obtained. Keep generator output as low as possible during all adjustments.
- (11) Set MANUAL TUNING dial pointer to approximately 600 kHz. Tune to local noise, or weak station for tuning meter reading of approximately 2.5. Place loop-end of Test Loop Stick (see Figure 16) near end of receiver antenna. Observe tuning meter. Place ferrite core-end of Test Loop Stick near end of receiver antenna. Observe tuning meter. If tuning meter reading decreases when loop-end, or rod-end of Test Loop Stick is brought near receiver antenna, antenna circuit is correctly aligned.
- NOTE:** Loop-end of Test Loop Stick decreases antenna inductance; rod-end of Test Loop Stick increases antenna inductance.
- (12) Repeat step (11) at 1400 kHz.
- (13) Close AM ANTenna GND link (opened previously).

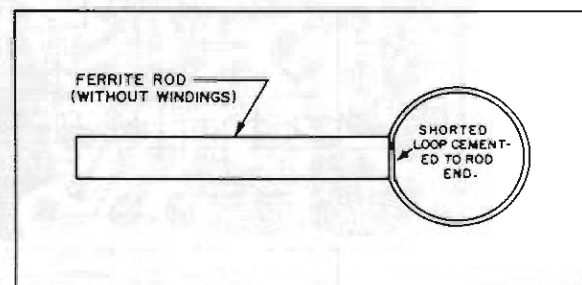
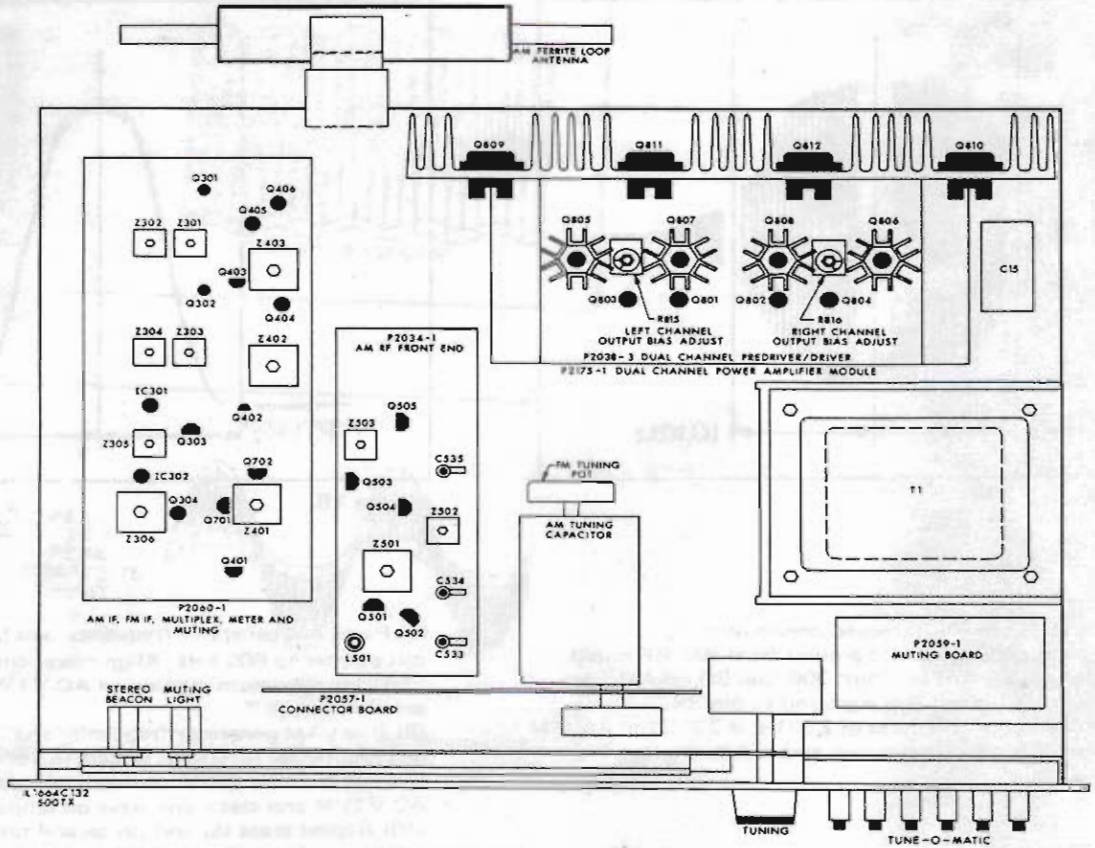

Figure 16. Test Loop Stick. Single (Shorted) Loop Of Wire Mounted On End Of Ferrite Rod. Loop Diameter, Wire Size, Or Ferrite Material Non-Critical.

CHASSIS LAYOUT

TOP



BOTTOM

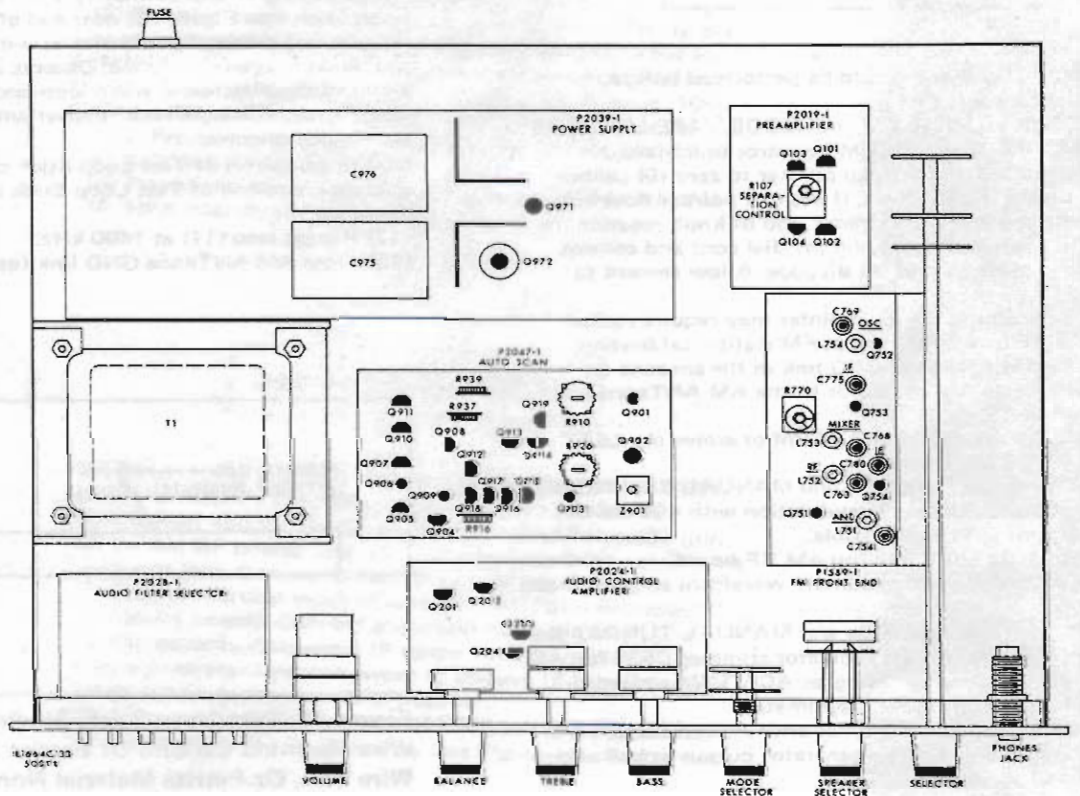

1589-1 FM RF

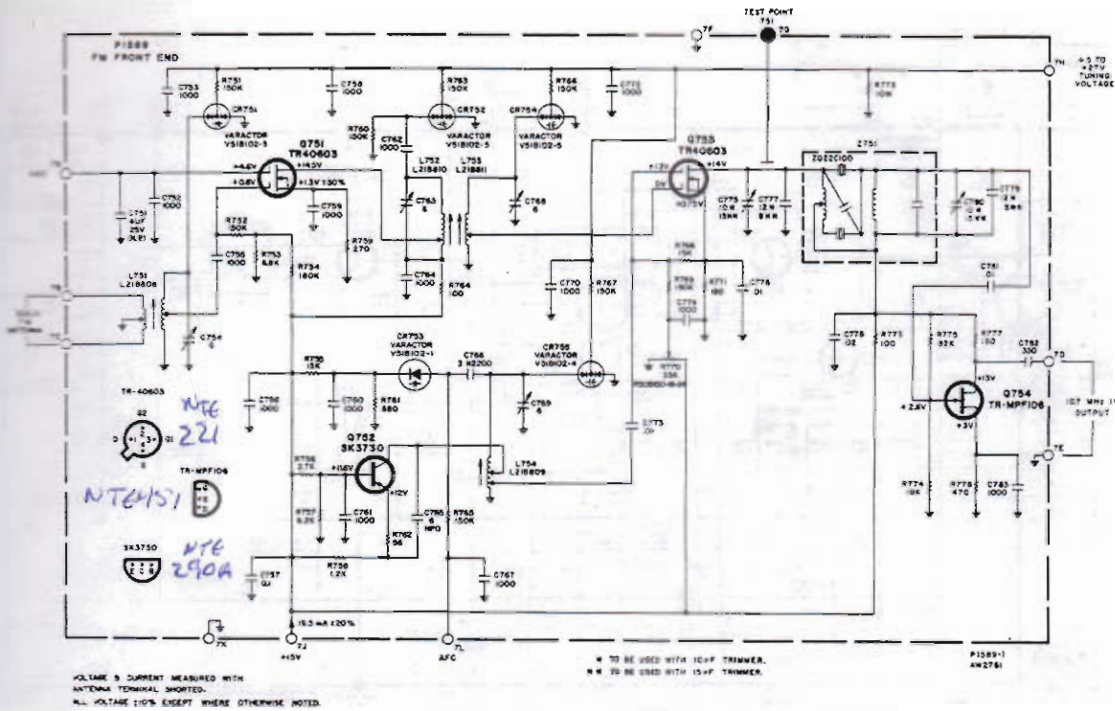

BOARD VIEWED FROM COMPONENT SIDE

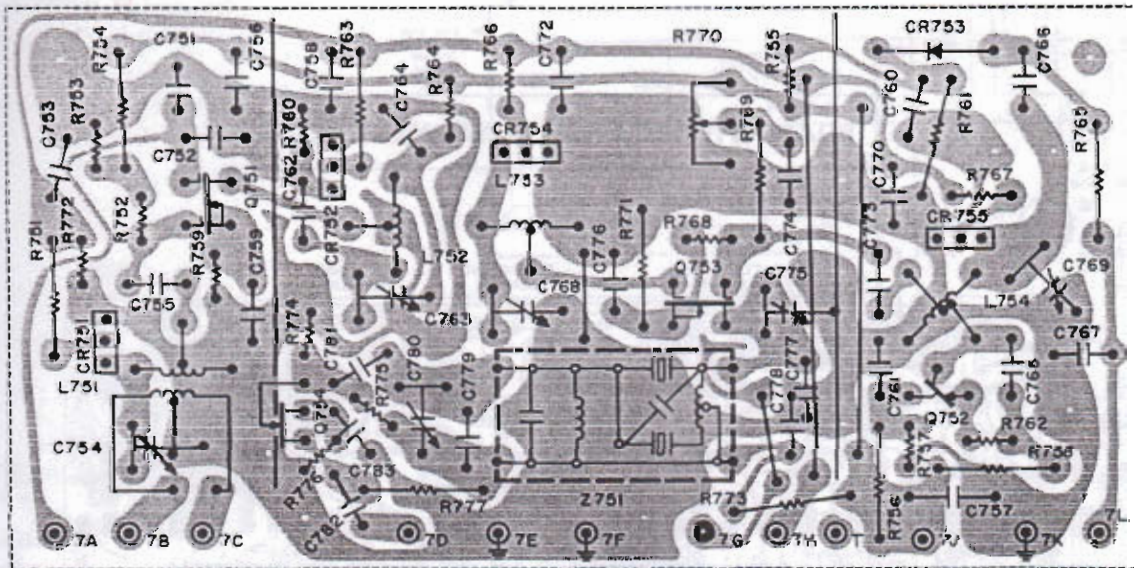

2034-1 AM RF

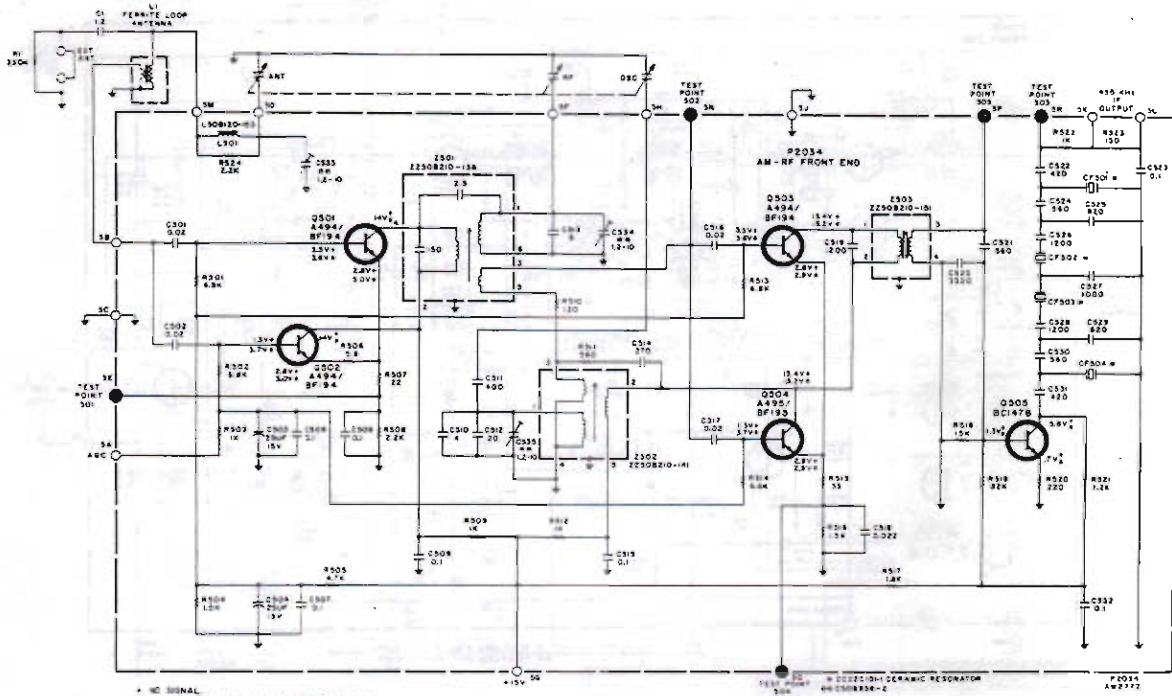

• NO SIGNAL
 • 000V SIGNAL, 1400 Hz, 80% MODULATION

A494/BF194 NTE107
 A495/BF195 NTE107
 BC147B NTE123A

BOARD VIEWED FROM COMPONENT SIDE

BOARD VIEWED FROM COMPONENT SIDE

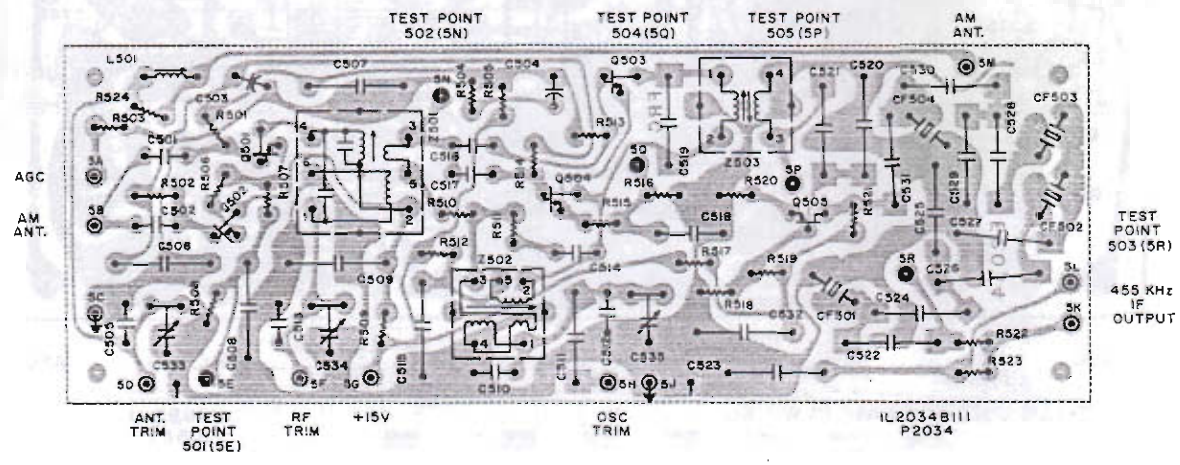

2057-1 CONNECTOR

BOARD VIEWED FROM COMPONENT

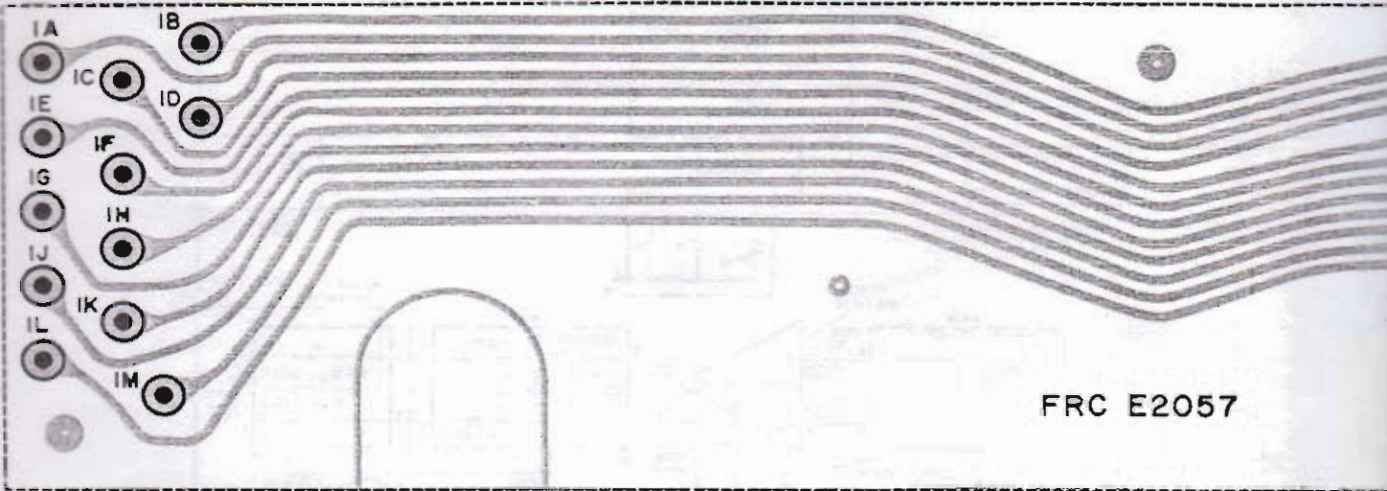

2061-1 TERMINAL BOARD

BOARD VIEWED FROM COMPONENT



OR

COMPONENT SIDE

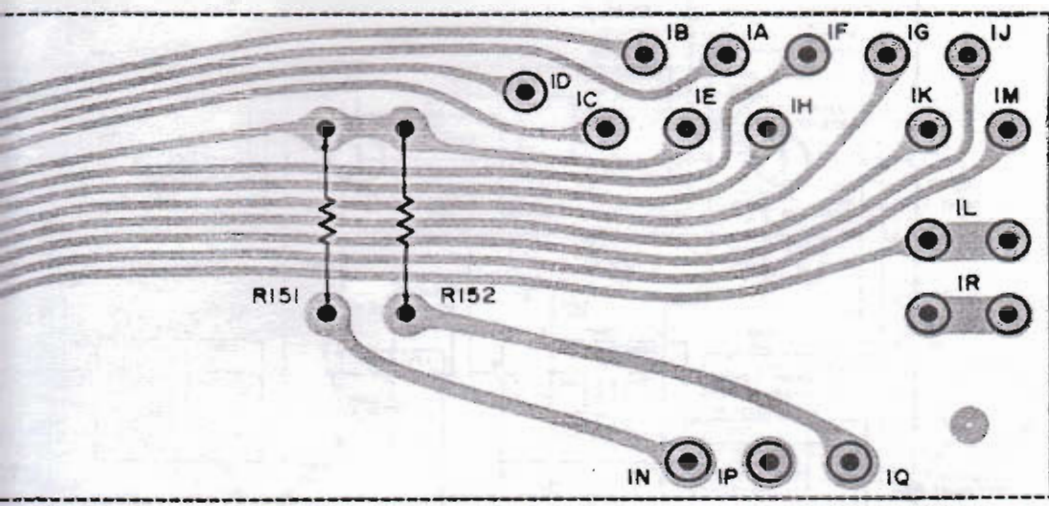

IL2057B111
P2057

BOARD

COMPONENT SIDE

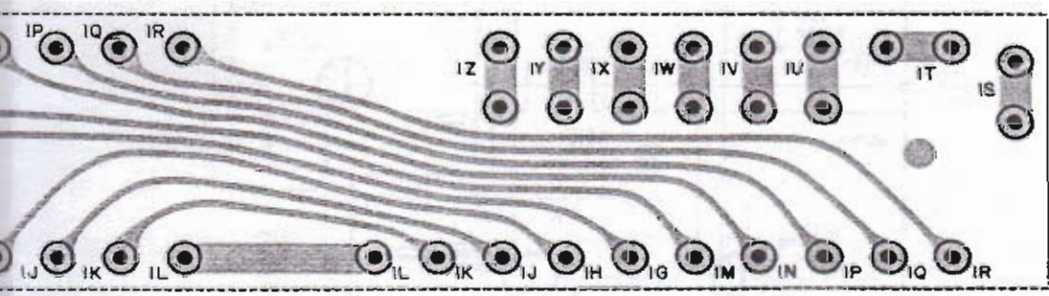

IL2061C111
P2061

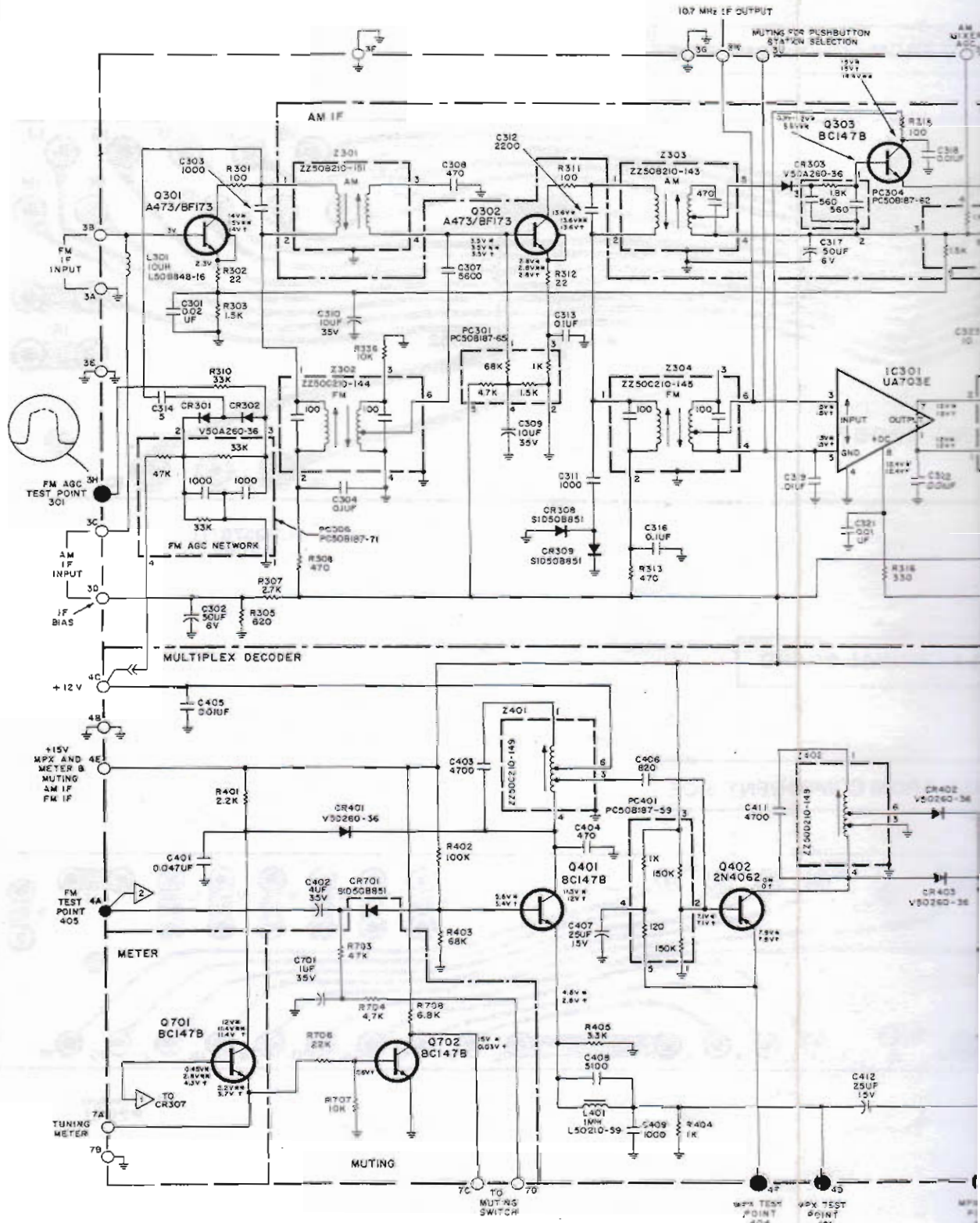

FM IF, MPX, METER, MUTING

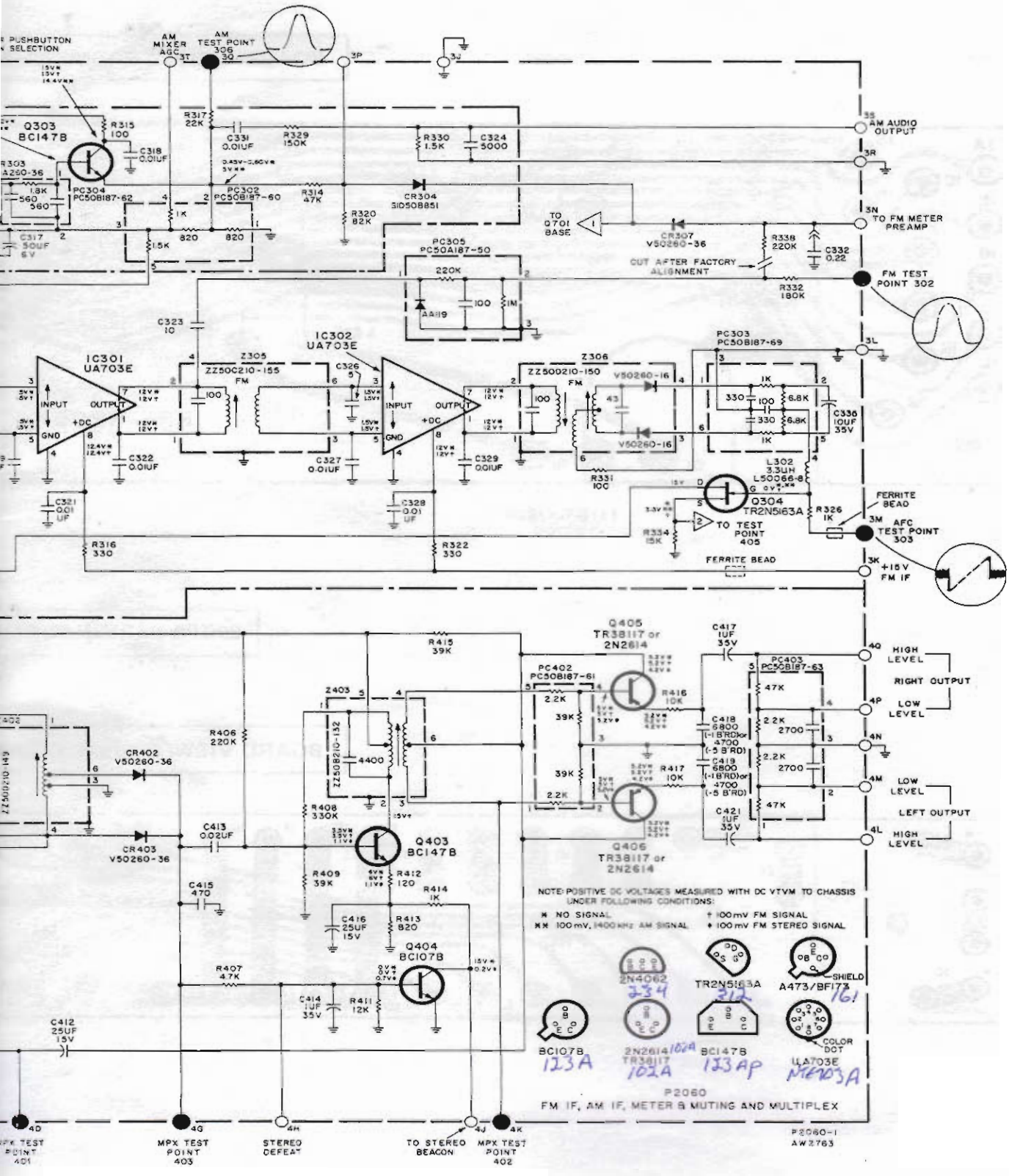

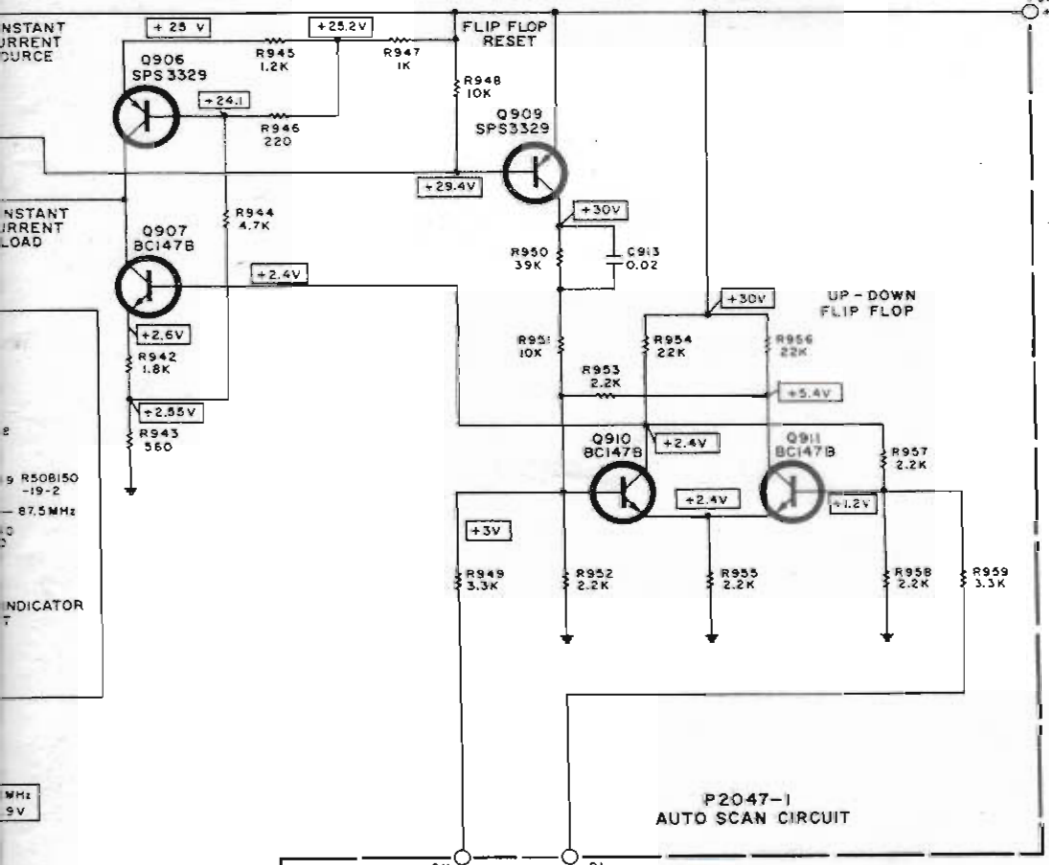
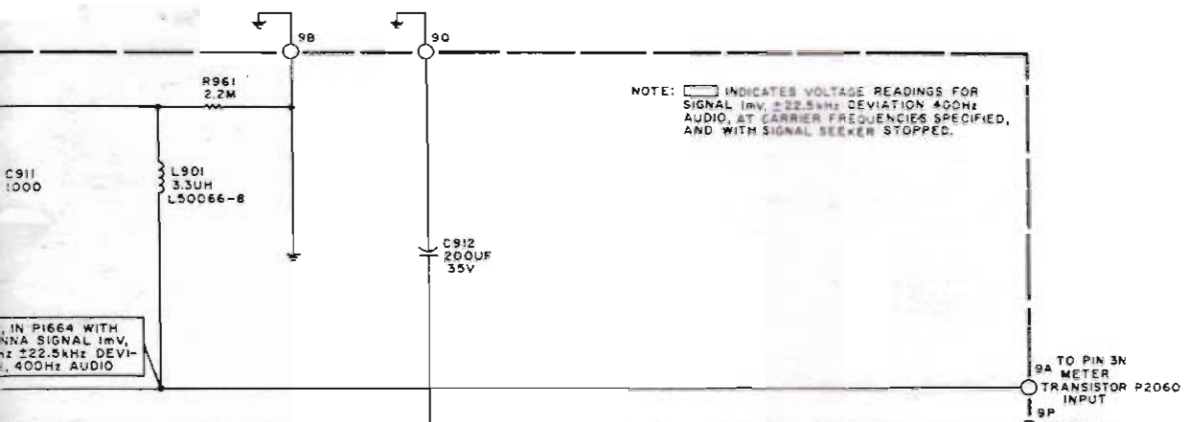

IN P1664 WITH
 ANNA SIGNAL 1mV,
 $\pm 22.5\text{kHz}$ DEVI-
 ATION, 400Hz AUDIO

INSTANT
 CURRENT
 SOURCE

INSTANT
 CURRENT
 LOAD

9 R50B150
 -19-2
 -87.5MHz

INDICATOR
 T

MHz
 9V

P2047-1
 AW 2762

PART OF P2028

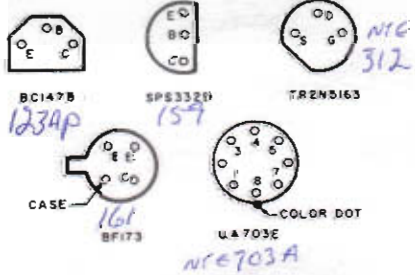

BOARD VIEWED FROM COMPONENT

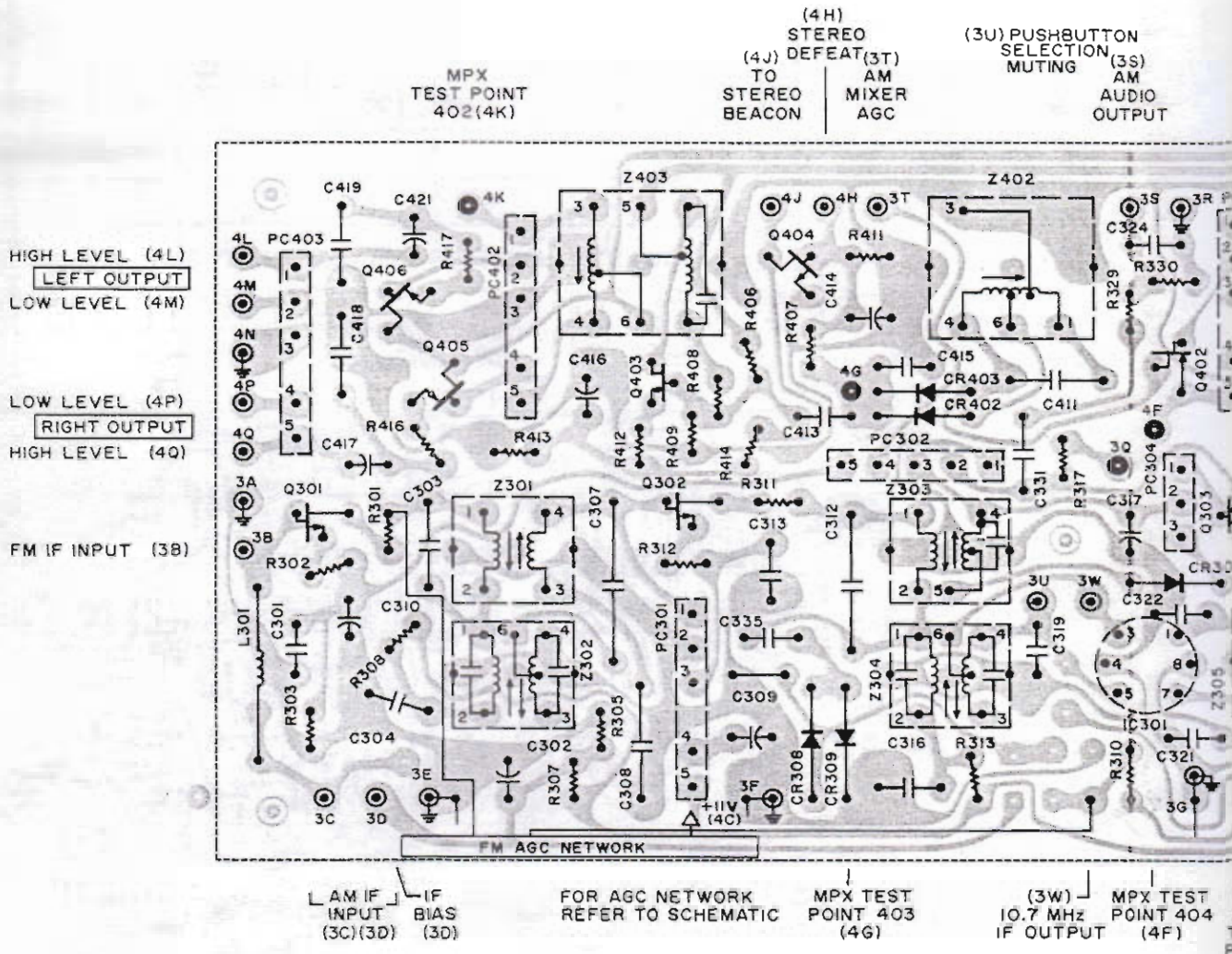

HIGH LEVEL (4L)
 LEFT OUTPUT
 LOW LEVEL (4M)
 LOW LEVEL (4P)
 RIGHT OUTPUT
 HIGH LEVEL (4Q)

FM IF INPUT (38)

MPX TEST POINT 402(4K)

(4H) STEREO
 (4J) DEFEAT TO STEREO BEACON
 (3T) AM MIXER AGC

(3U) PUSHBUTTON SELECTION MUTING
 (3S) AM AUDIO OUTPUT

AM IF INPUT (3C)(3D)
 IF BIAS (3D)

FOR AGC NETWORK REFER TO SCHEMATIC

MPX TEST POINT 403 (4G)

(3W) 10.7 MHz IF OUTPUT
 MPX TEST POINT 404 (4F)

FM AGC NETWORK

TER, MUTING

COMPONENT SIDE

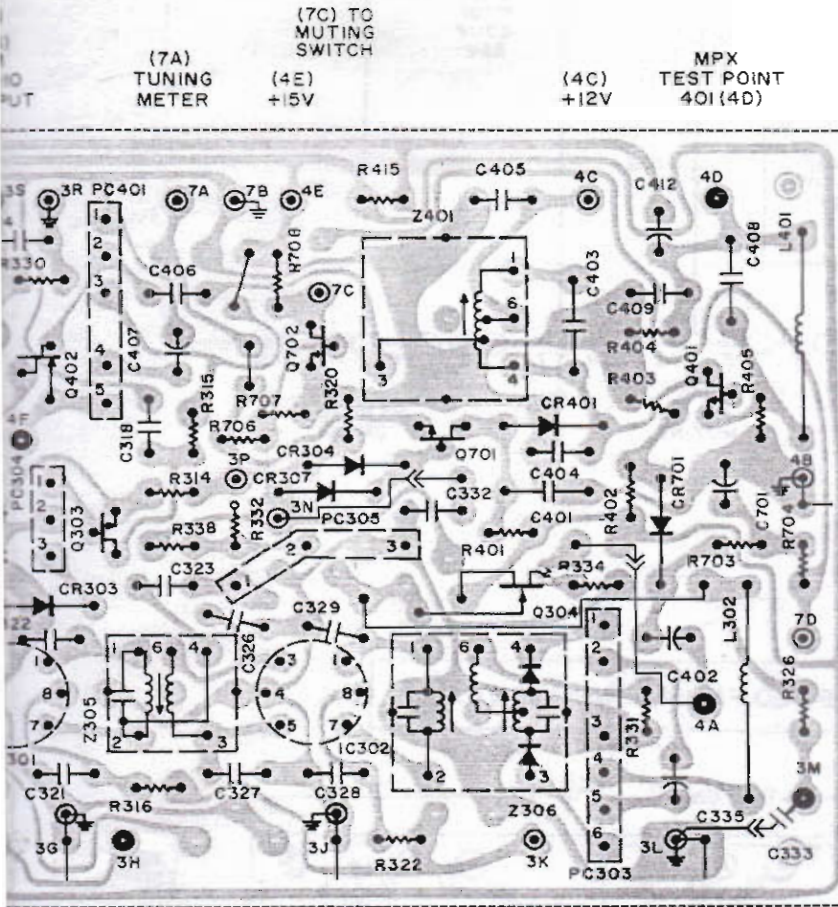

(7A)
TUNING
METER

(7C) TO
MUTING
SWITCH
(4E)
+15V

(4C)
+12V

MPX
TEST POINT
401(4D)

AM TEST POINT
306 (3Q)

FM TEST POINT
302(TIP OF R332)

(7D)
TO
MUTING
SWITCH
FM TEST POINT
405 (4A)

AFC
TEST POINT
303 (3M)

X TEST
POINT 404
(4F)
FM
AGC
TEST
POINT
301 (3H)

(3N) TO
FM METER
PREAMP

+15V
(3K)

IL2060C111
P2060

2059-1 MUTING

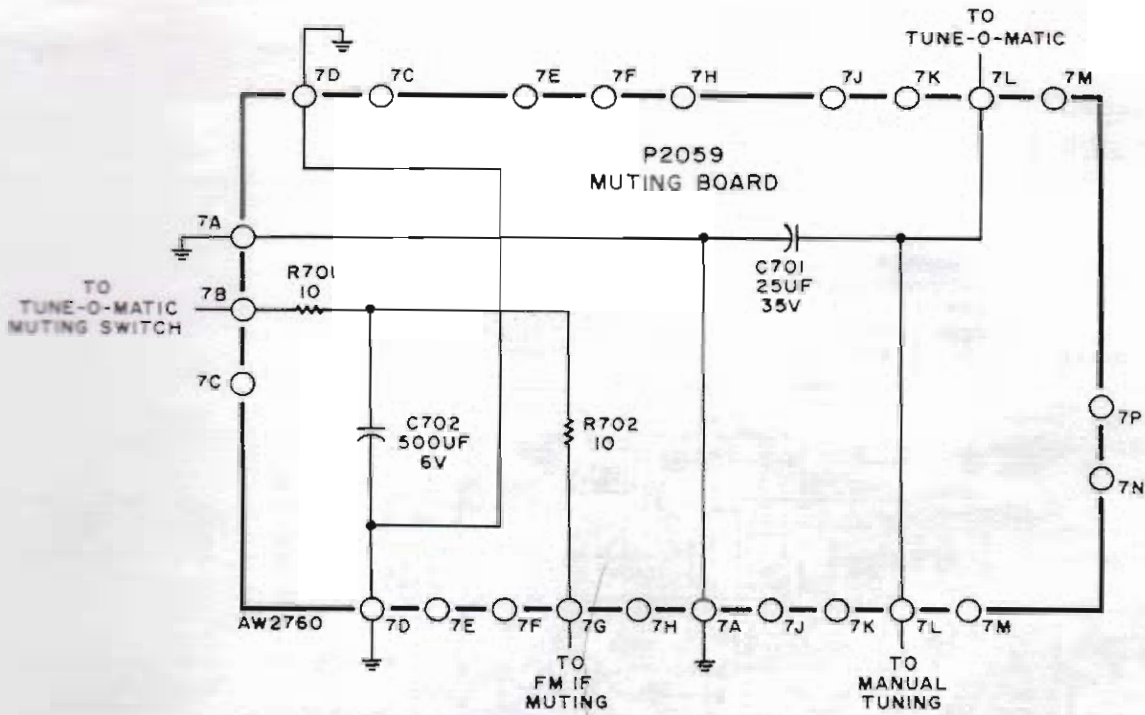

BOARD VIEWED FROM COMPONENT SIDE

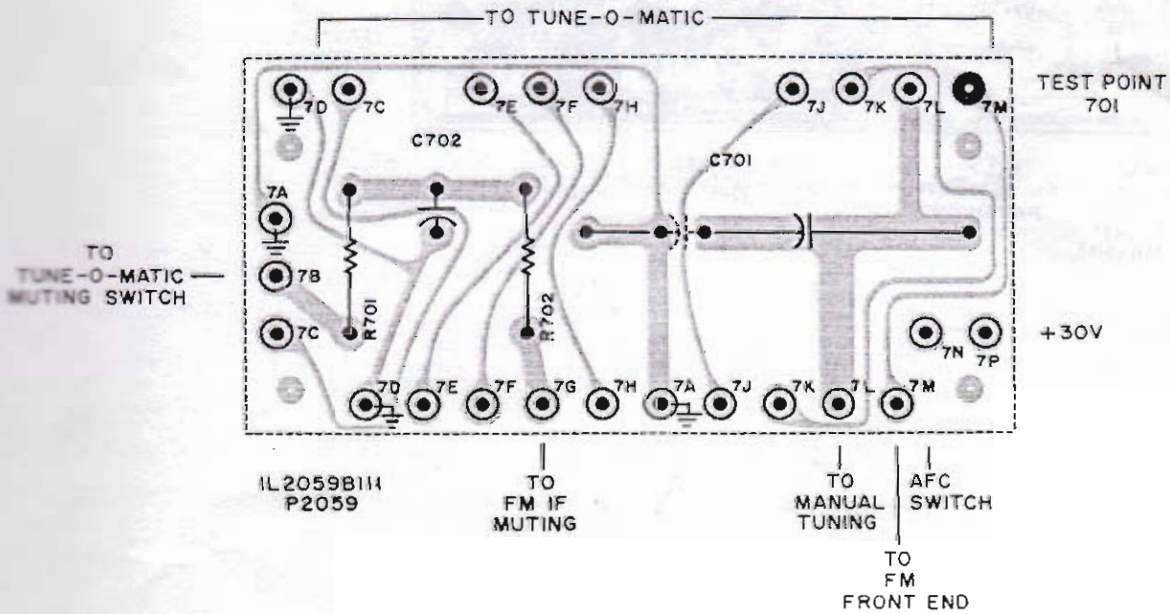

BOARD VIEWED FROM COMPONENT SIDE

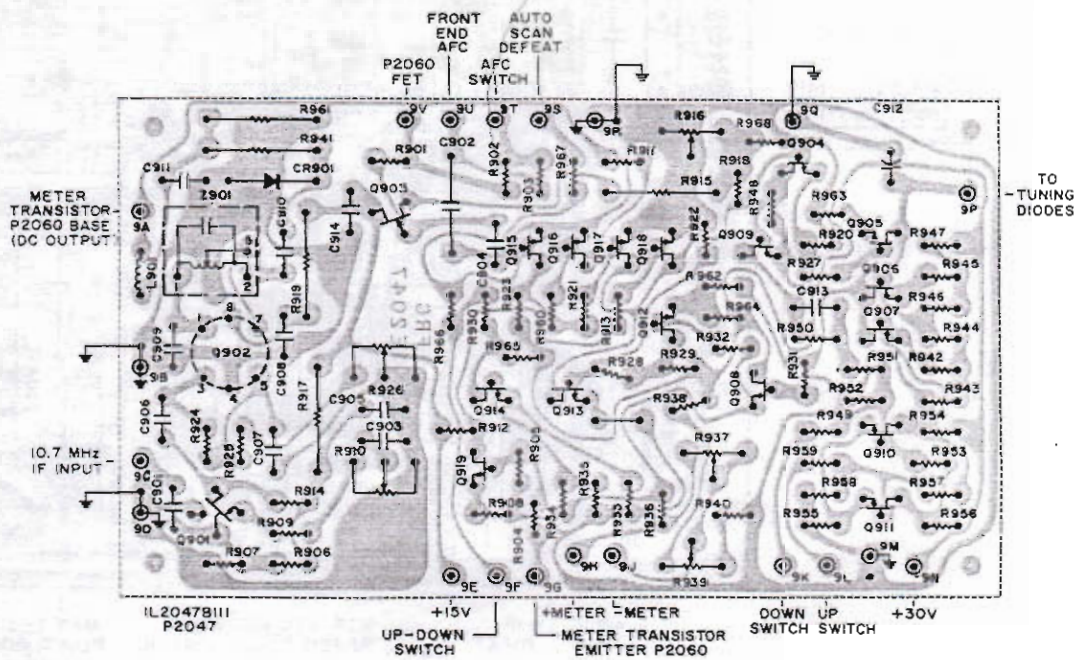

2019-4 PREAMPLIFIER

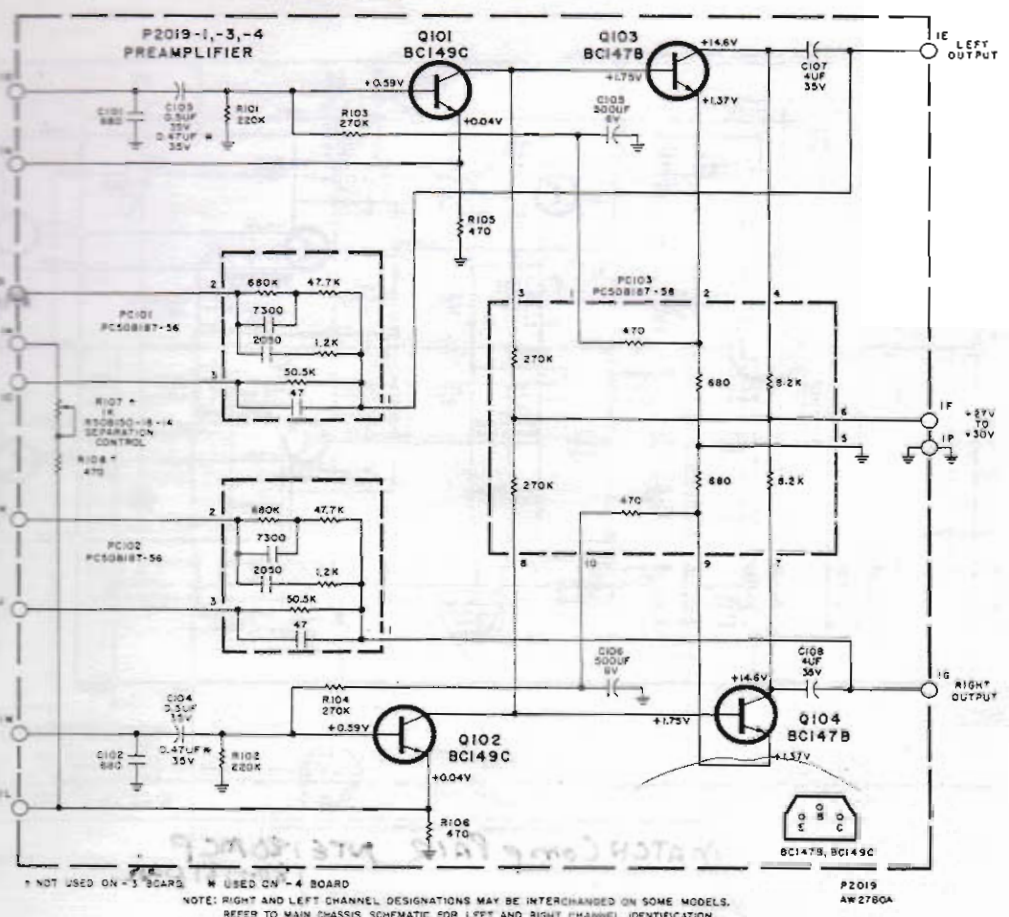

BOARD VIEWED FROM COMPONENT SIDE

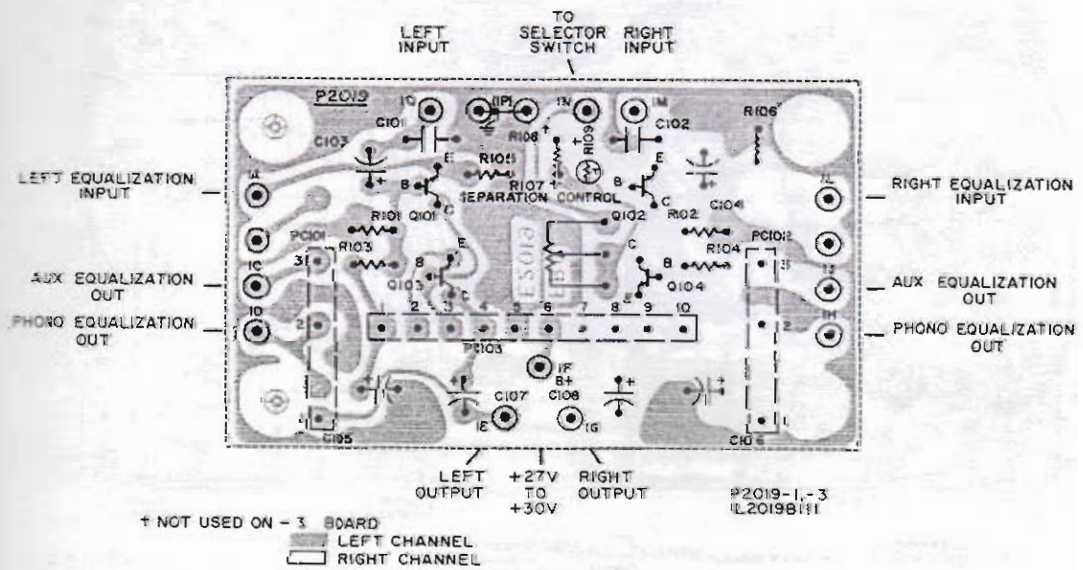

2024-1 AUDIO CONTROL AMPLIFIER

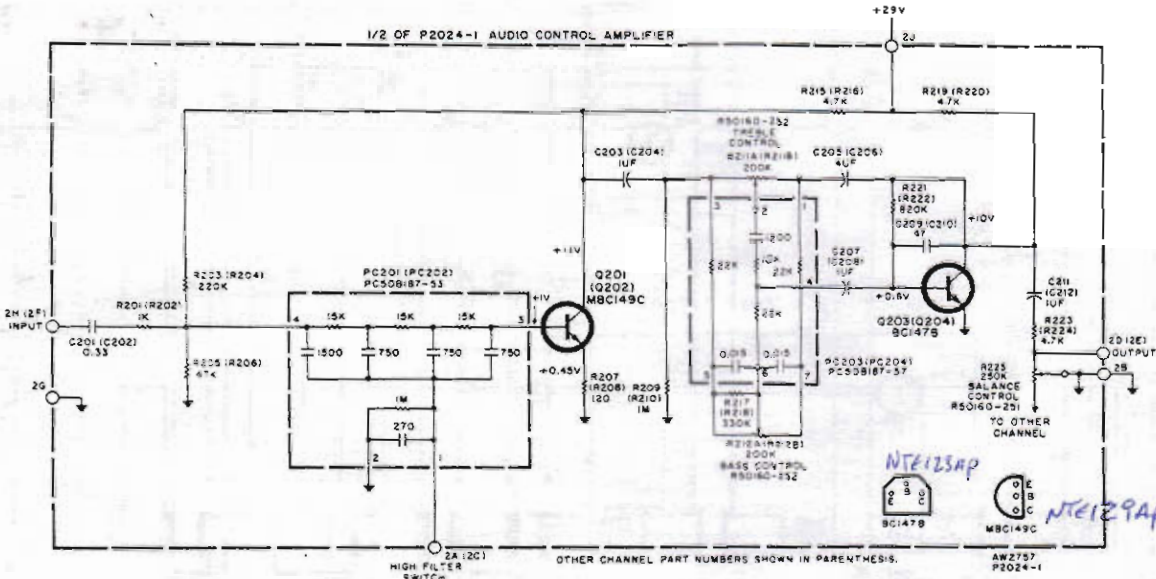

BOARD VIEWED FROM COMPONENT SIDE

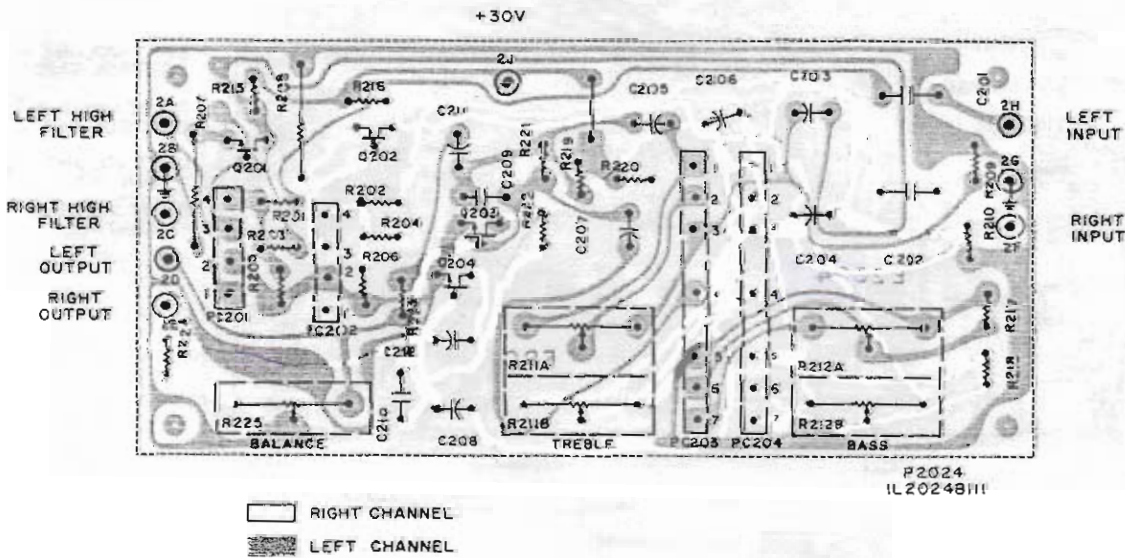

2028-1 AUDIO FILTER SELECTOR

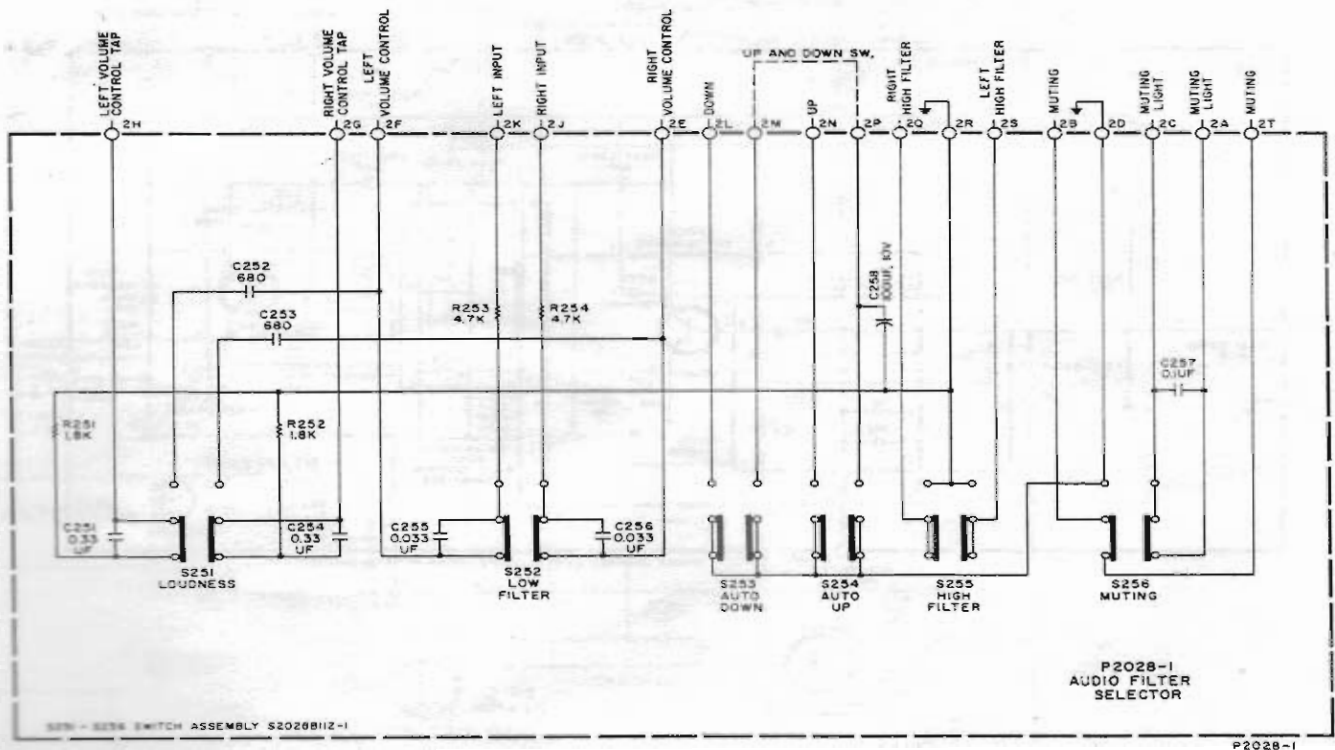

P2028-1
AW 2766

BOARD VIEWED FROM COMPONENT SIDE

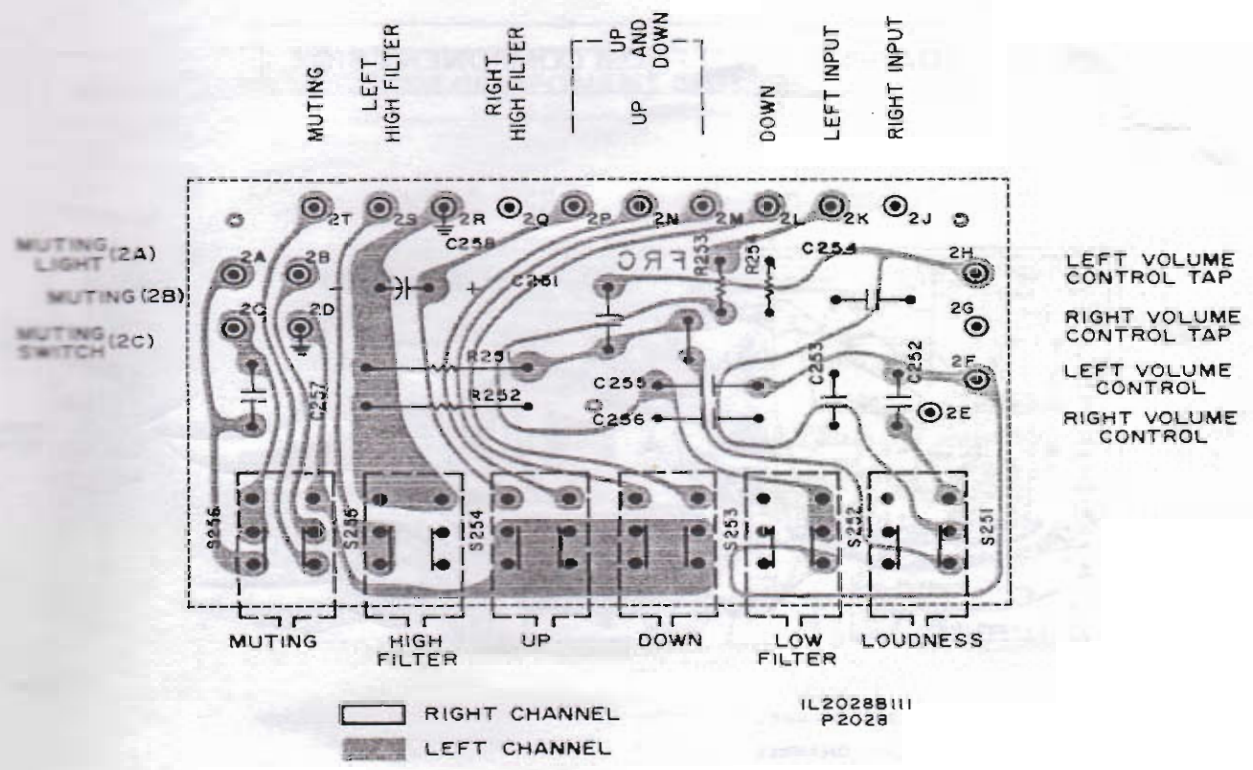

2175-1 POWER AMPLIFIER MODULE

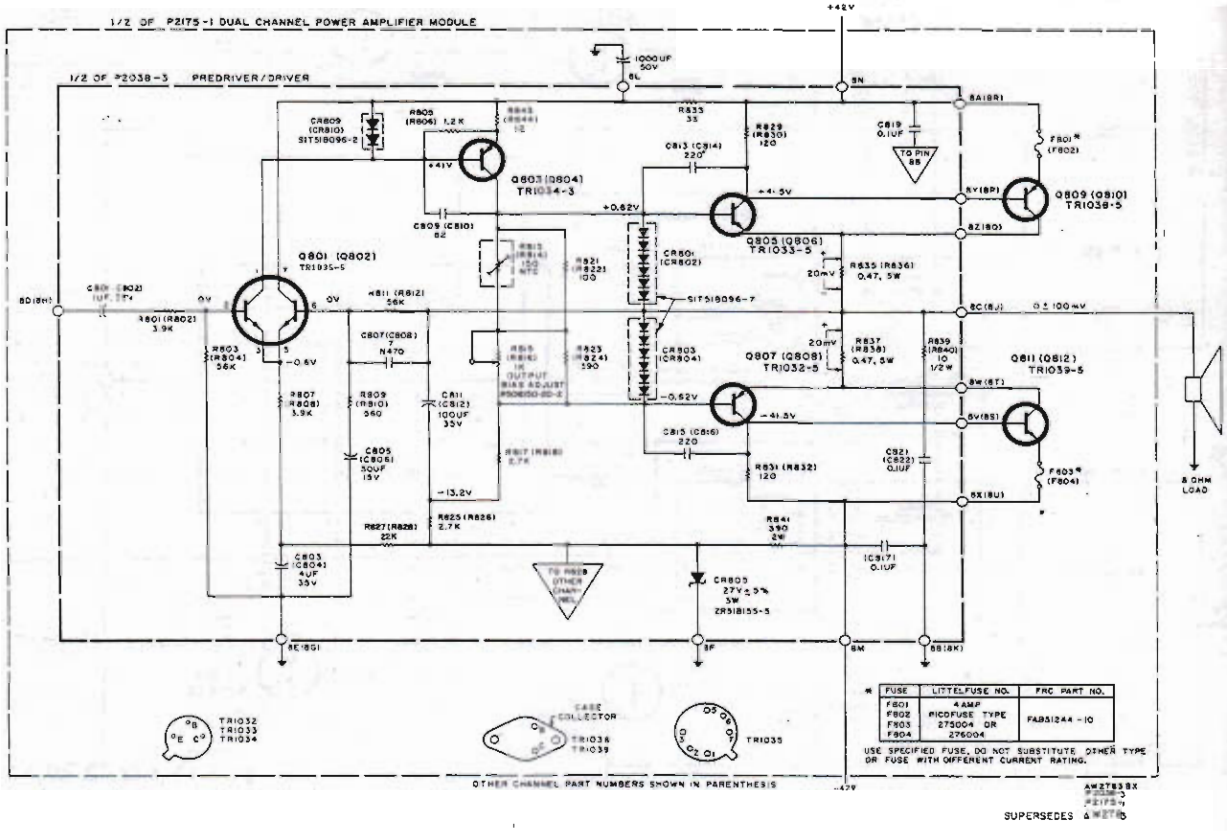

BOARD VIEWED FROM COMPONENT SIDE

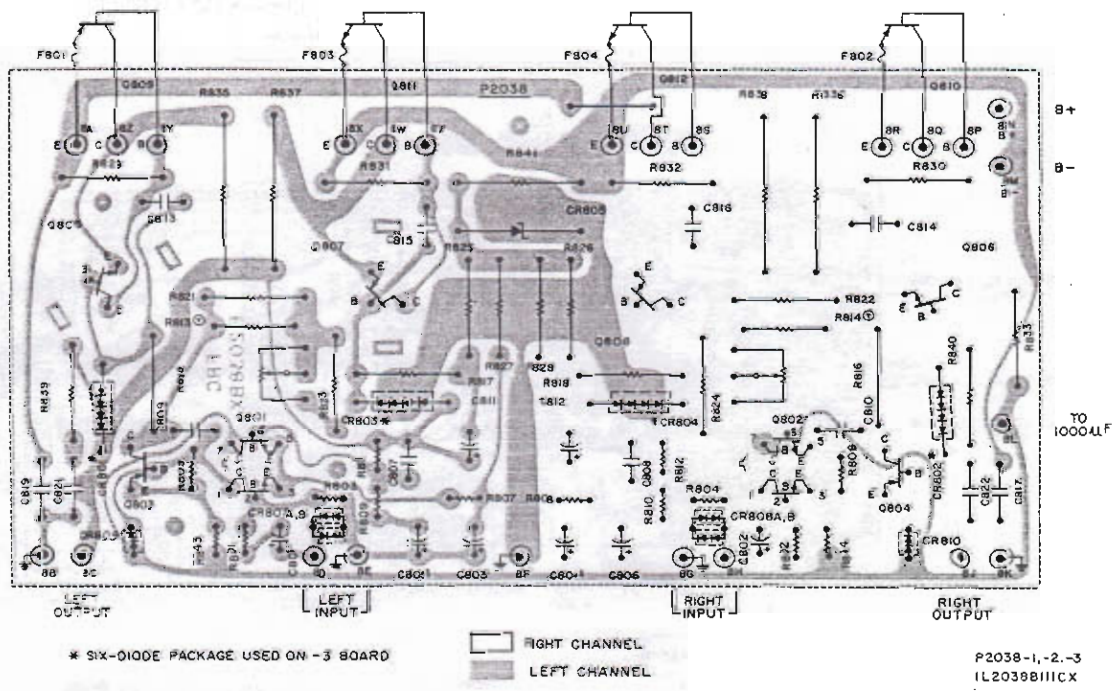

SCHEMATIC SHOWN ON MAIN CHASSIS DIAGRAM

BOARD VIEWED FROM COMPONENT

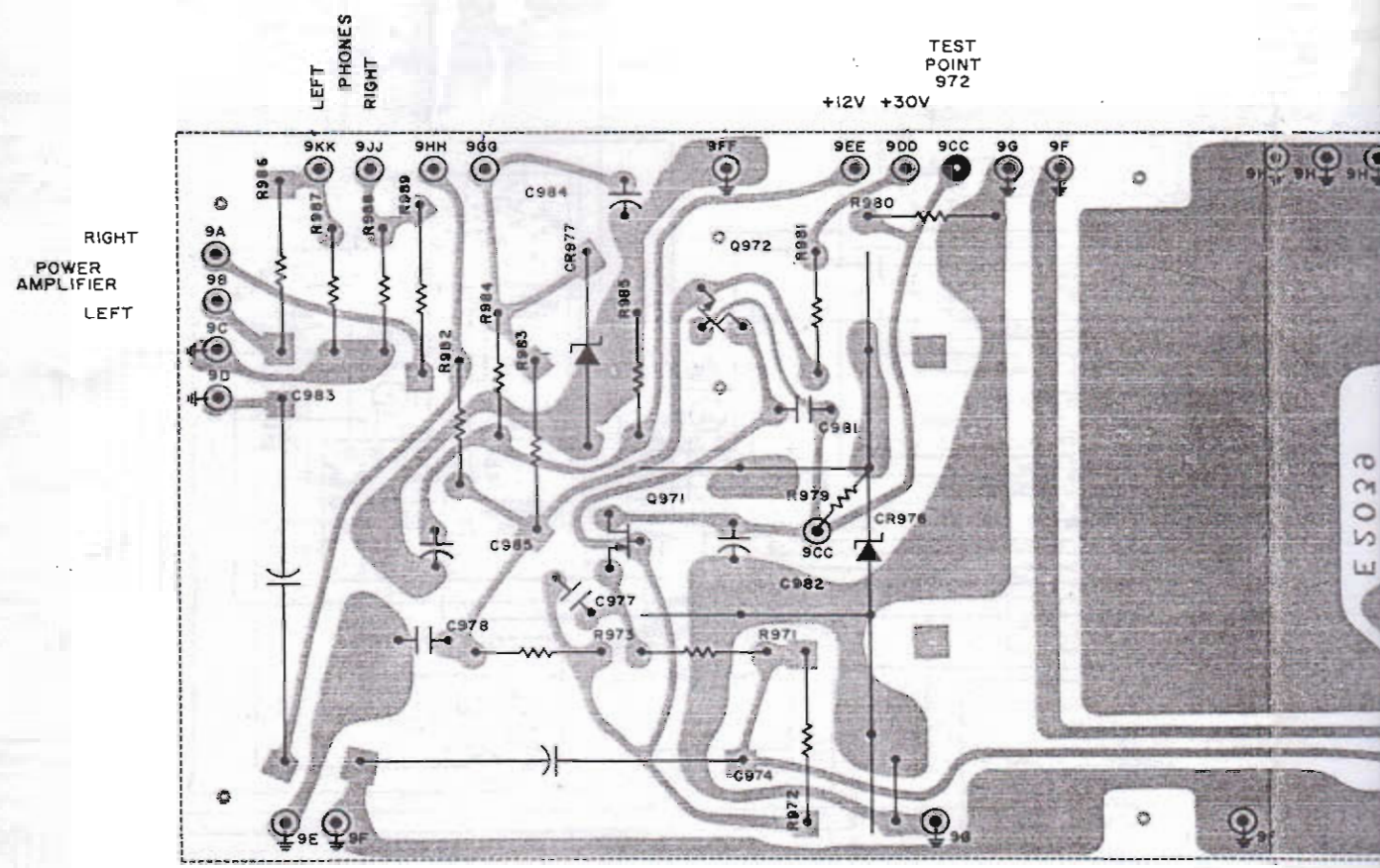

SUPPLY

CHASSIS DIAGRAM

COMPONENT SIDE

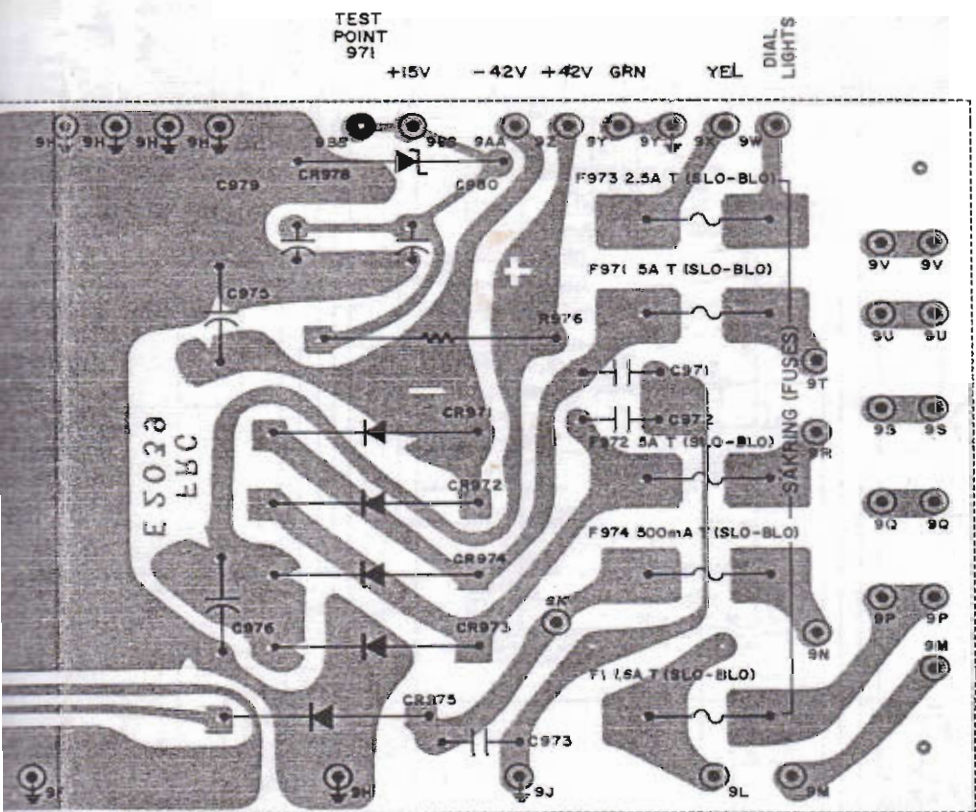

ON-OFF SWITCH

RED

RED

AC ON-OFF SWITCH

IL2039CIII-2 B
P2039

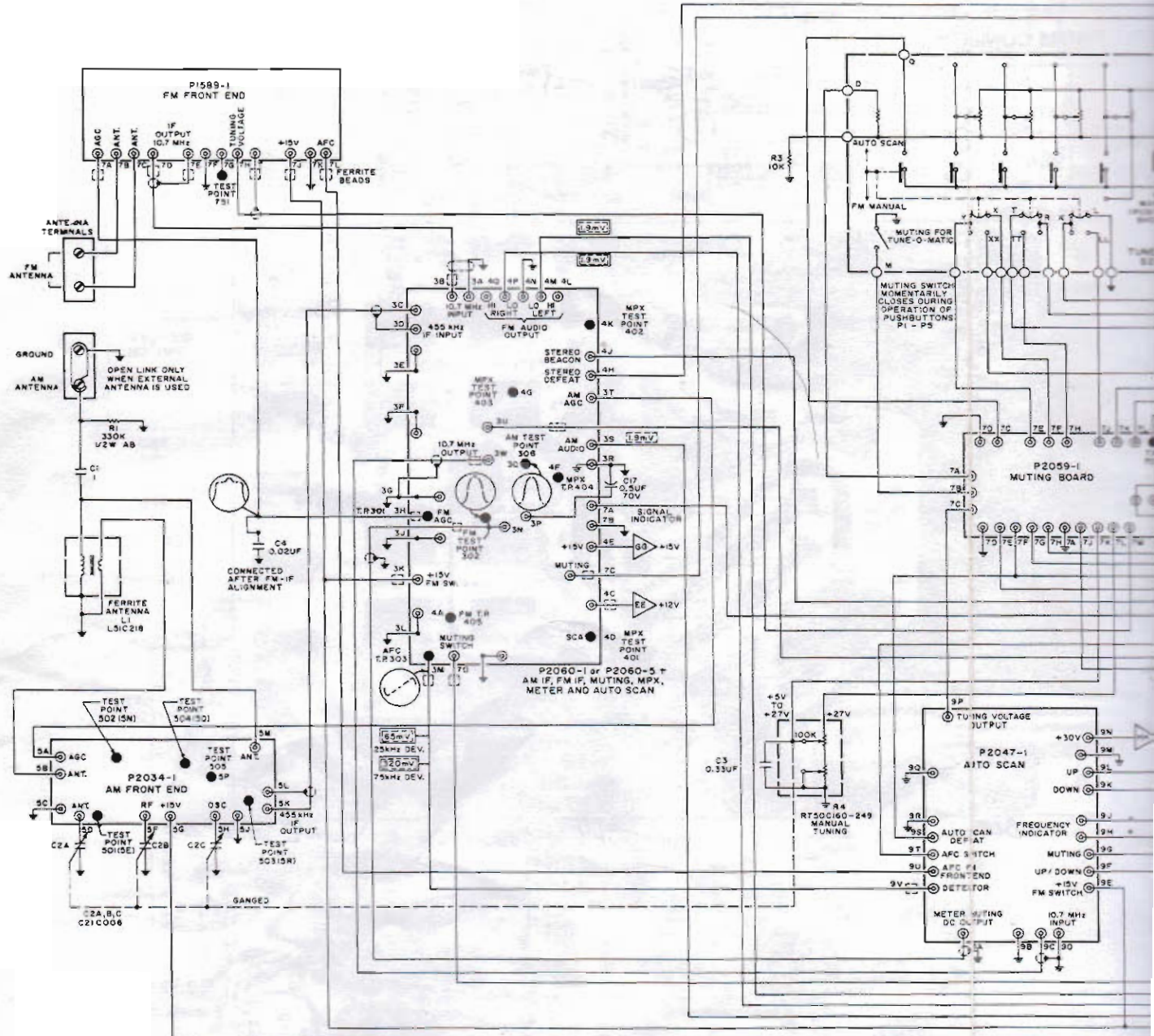

ASSIS - TUNER SECTION

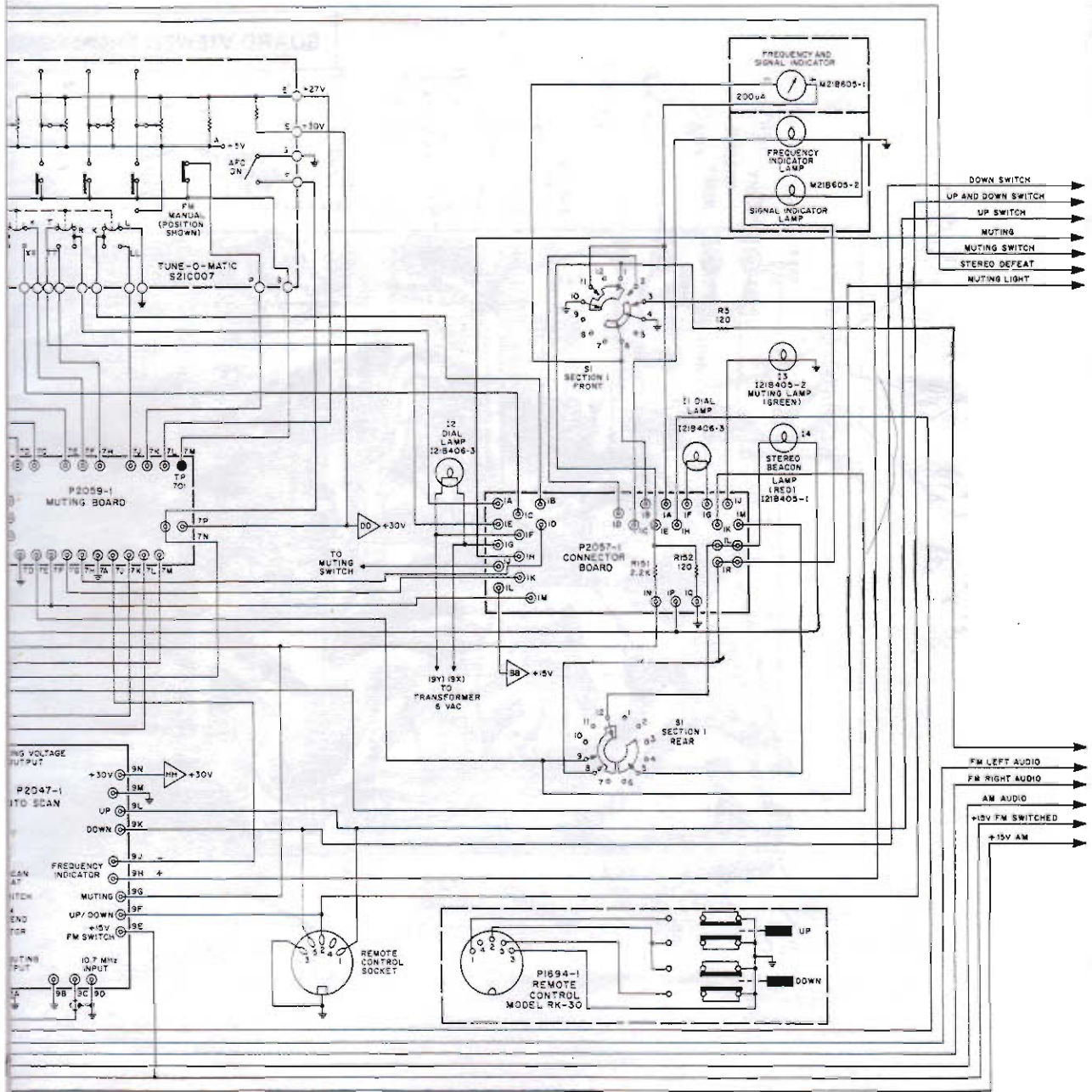

SSIS - AMPLIFIER SECTION

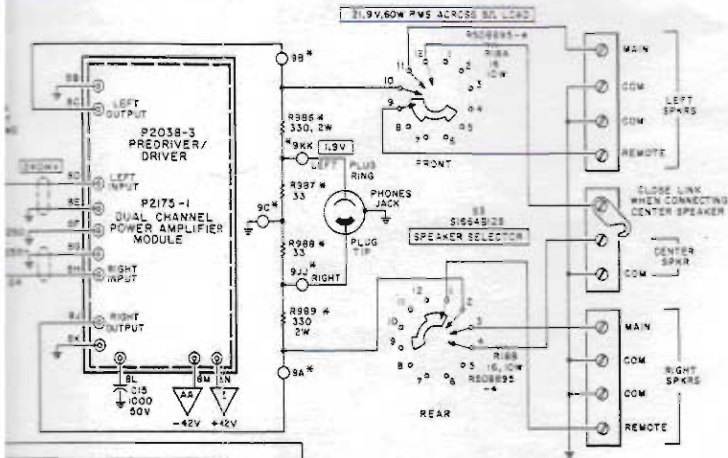

- NOTES:**
- FISHER PART NUMBER LISTED FOR PARTS SPECIALLY SELECTED FOR FISHER RADIO CORP. 1/2 WATT, 5% COMPOSITION RESISTORS MAY BE USED FOR RESISTOR REPLACEMENTS, EXCEPT AS NOTED.
 - † USED ONLY ON UNITS WIRED FOR EXPORT.
 - ALL ROTARY SWITCHES SHOWN IN MAXIMUM CCW POSITION No. 1, ALL OTHER CONTROLS AND SWITCHES SHOWN IN NORMAL OPERATING POSITIONS.
 - FOR ALL VOLTAGE MEASUREMENTS, LINE VOLTAGE 120VAC ALL DC VOLTAGES MEASURED WITH A DC VTVM TO CHASSIS WITH NO SIGNAL INPUT.
 - [Symbol] INDICATES 1kHz SIGNAL LEVELS FROM AUDIO INPUTS TO POWER AMPLIFIER OUTPUT [21.9V, 60W RMS ACROSS 8Ω LOAD] MEASURED WITH AC VTVM, VOLUME CONTROL, MAXIMUM, ALL OTHER CONTROLS AND SWITCHES NORMAL, MODE SELECTOR IN STEREO.
 - [Symbol] INDICATES 1kHz SIGNAL LEVELS MEASURED IN AM WITH GENERATOR SIGNAL 7.1MHz, 0mv, AND 18% MODULATION.
 - [Symbol] INDICATES 1kHz SIGNAL LEVELS MEASURED IN FM - MONO WITH GENERATOR SIGNAL 100MHz, 1mv, 25% DEVIATION.

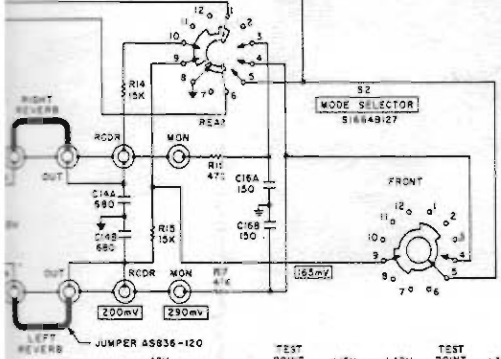

SWITCH POSITIONS			
POS NO	S1 SELECTOR SWITCH	S2 MODE SELECTOR	S3 SPEAKER SELECTOR
1	AUX	MONO	OFF
2	AM	STEREO	REMOTE
3	FM	STEREO TAPE	MAIN
4	PHONO	TAPE LEFT	MAIN-CENTER
5		TAPE RIGHT	ALL

3mm X 20mm FUSES		
FUSE	LITTELFUSE No.	P.R.C. PART No.
† F1	2130L6	F518247-17
F97	213005	F518247-23
† F93	21302.5	F518247-19
† F94	213.500	F518247-10

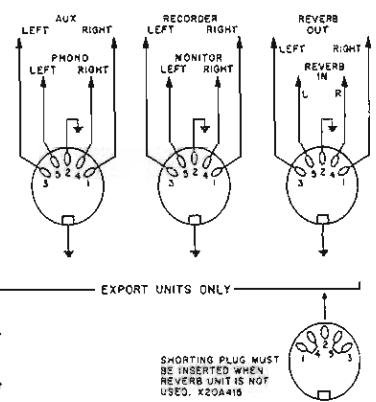
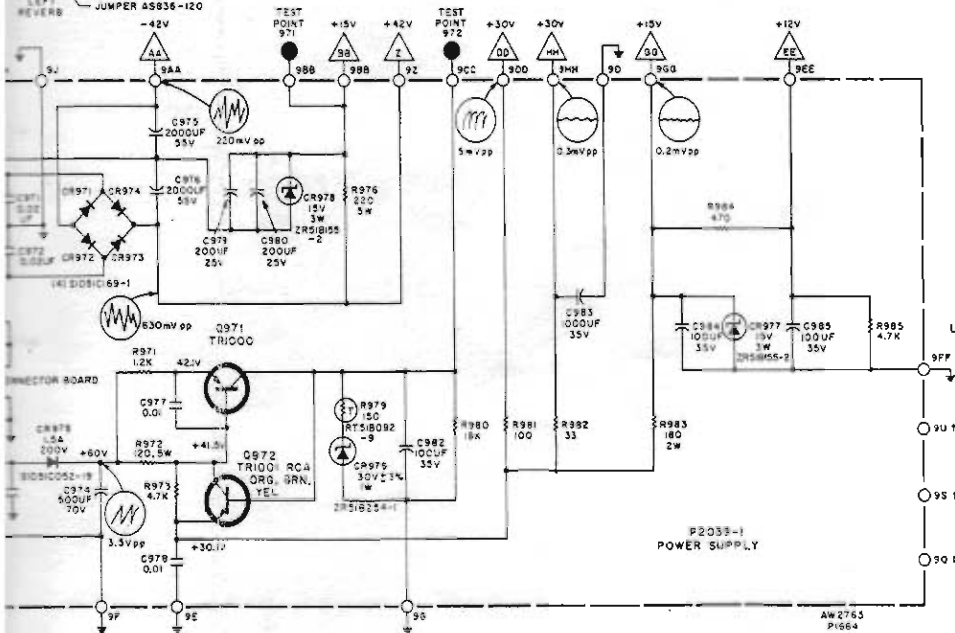

COMPONENT CONNECTIONS

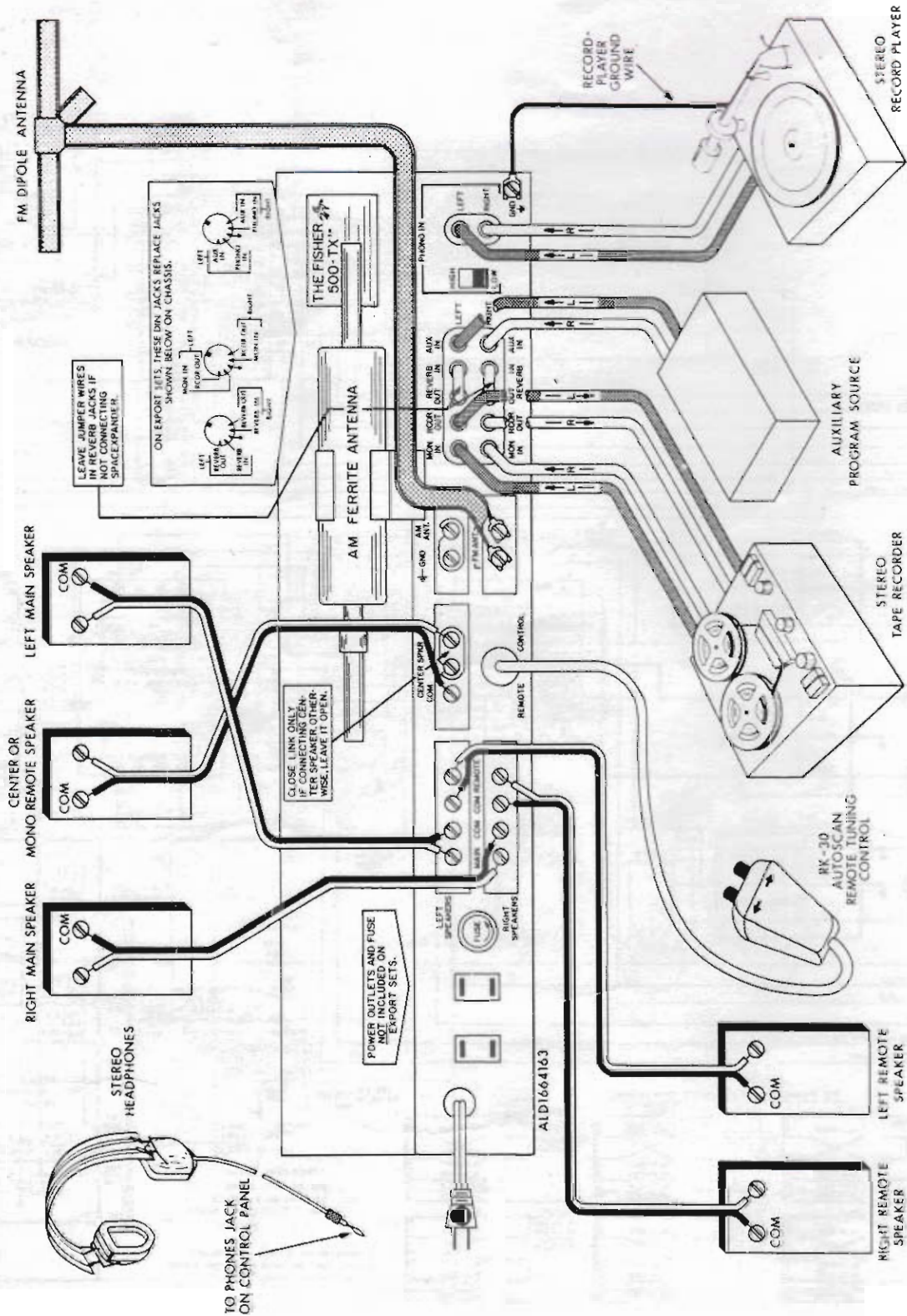

FISHER RADIO CORPORATION · NEW YORK

FISHER SERVICE BULLETIN

Fuse changes have been made in the 450-T and 500-TX receivers (and the 505-T and 800-T export versions).

- (1) Fuses (in series with the emitters of the output transistors) have been removed from the Power Amplifier circuits.
- (2) Fuses (in series with the amplifier B+ and B-) have been added to the Power Supplies for protection.

All 450-T, 500-TX, 505-T, and 800-T receivers which are returned for service should be modified as follows:

- (1) Solder an insulated jumper across each of the emitter fuses on the Power Amplifiers.

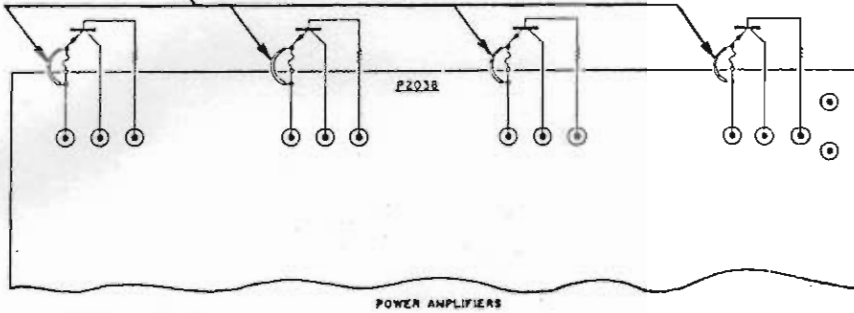

450-T(505-T)

- (2a) Solder two 5 AMP Slo-Blo pigtail fuses (each fuse FR Part No. FL51313-8) on the Power Supply board in the positions shown. Use an insulating sleeve (as shown) to avoid shorts. Then reconnect the two red AC B+ leads: move one lead from pin 9RR to pin 9P; move the other lead from pin 9SS to pin 9Q.

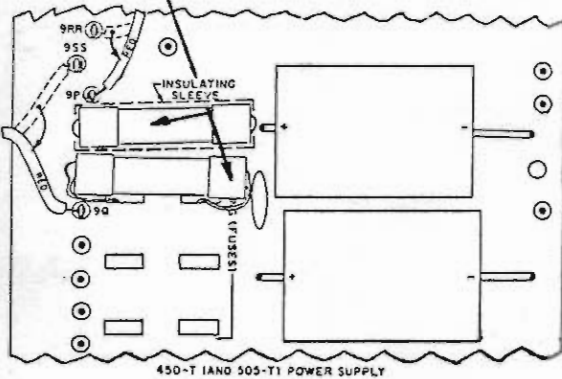

500-TX(800-T)

- (2b) Cut and remove the two fuse jumpers on the Power Supply board. Solder two 5 AMP Slo-Blo pigtail fuses (each fuse FR Part No. FL51313-8) in place of the jumpers as shown.

