



Stereophonic THE FISHER 600 SCHEMATIC and PARTS LIST



MODEL 600

CHASSIS SERIAL NUMBERS
40001-49999 INCLUSIVE

PRICE: \$1.00

FISHER RADIO CORPORATION • NEW YORK

NEW YORK

CHASSIS SERIAL NUMBERS
40001-49999 INCLUSIVE

THE FISHER 600

PARTS DESCRIPTION LIST

Symbol	Description	Part No.
CAPACITORS		
10% tolerance for all fixed capacitors, unless otherwise noted or marked GMV (guaranteed minimum value.)		
C1	Ceramic, 24uuf 5% N150, 1000V	C50070-8
C2	Ceramic, 100uuf N1500, 1000V	C50070-6
C3, 4	Ceramic, 8uuf ± .5uuf NPO, 500V	CC20CJ080D5
C5	Ceramic, Trimmer	C662-123
C6	AM Variable	Part of C9
C7	Ceramic, 100uuf N1500, 1000V	C50070-6
C8	FM Variable	C726-116
C9	AM Variable	C684-127
C10	Ceramic, Feedthru, .001uf GMV	C592-187
C11	Ceramic, 100uuf N1500, 1000V	C50070-6
C12	Mylar, .047uf, 250V	C50197-52
C13	Ceramic, .001uf, 1000V	C50072-3
C14	Ceramic, Feedthru, .001uf GMV	C592-187
C15	Ceramic, 8uuf ± .5uuf NPO, 500V	CC20CJ080D5
C16	Ceramic, Trimmer	C662-123
C17	Ceramic, .02uf +80—20%, 500V	C50089-4
C18	Molded, .01uf 20%, 600V	C2747
C19	Ceramic, 100uuf N1500, 1000V	C50070-6
C20	Ceramic, .02uf +80—20%, 500V	C50089-4
C21	Ceramic, 68uuf N750, 500V	CC20UJ680K5
C22	Ceramic, 100uuf N1500, 1000V	C50070-6
C23	Ceramic, 18uuf N470, 1000V	C50070-13
C24	Ceramic, .005uf 20%, 500V	C50089-1
C25	Ceramic, 5uuf ± .5uuf N220, 500V	CC20RH050D5
C26	Ceramic, Trimmer	C662-123
C27	Ceramic, .68uuf 20%, 500V	C50077-6N
C28	Ceramic, Feedthru, .001uf GMV	C592-187
C29	Ceramic, 24uuf 5% N150, 1000V	C50070-8
C30	Ceramic, 100uuf, N1500, 1000V	C50070-19
C31	Ceramic, 10uuf ± .5uuf NPO, 500V	CC20CH100D5
C32	Ceramic, .001uf, 1000V	C50072-3
C33	AM Variable	Part of C9
C34	Ceramic, 100uuf N1500, 1000V	C50070-6
C35	Ceramic, .005uf 20%, 500V	C50089-1
C36	Ceramic, 2.2uuf, 500V	C3039
C37	Electrolytic, four section: A: 40uf, 400V B: 40uf, 350V C: 20uf, 300V D: 20uf, 300V	C50180-2
C38	Ceramic, Feedthru, .001 GMV	C592-187
C39	Electrolytic, three section: A: 40uf, 300V B: 40uf, 250V C: 40uf, 250V	C670-125
C40	Ceramic, Feedthru, .001uf GMV	C592-187
C41	Ceramic, .02uf +80—20%, 500V	C50089-4
C42	Ceramic, 100uuf N1500, 1000V	C50070-6
C43	Ceramic, .02uf +80—20%, 500V	C50089-4
C44	Ceramic, .001uf, 1000V	C50072-3
C45	Ceramic, .005uf 20%, 500V	C50089-1
C46	Ceramic, .0027uf, 1000V	C50072-17
C47	Ceramic, .02uf +80—20%, 500V	C50089-4
C48	Ceramic, Feedthru, .001uf GMV	C592-187
C49	Ceramic, .005uf 20%, 500V	C50089-1
C50	Ceramic, 10uuf NPO, 1000V	C50070-11
C51	AM Variable	Part of C9
C52	Ceramic, .02uf +80—20%, 500V	C50089-4
C53	Ceramic, Feedthru, .001uf GMV	C592-187
C54	Ceramic, .02uf +80—20%, 500V	C50089-4
C55, 56	Ceramic, .005uf 20%, 500V	C50089-1
C57	Ceramic, .0027uf, 1000V	C50072-17
C58	Ceramic, .02uf +80—20%, 500V	C50089-4
C59	Ceramic, 10uuf NPO, 1000V	C50070-11
C60	Ceramic, .005uf 20%, 500V	C50089-1
C61	Ceramic, .0027uf, 1000V	C50072-17
C62, 63	Ceramic, .005uf 20%, 500V	C50089-1
C64, 65	Ceramic, 330uuf, 1000V	C50072-1
C66	Electrolytic, 8uf, 50V	C629-138
C67	Ceramic, .055uf 20%, 500V	C50089-1
C68	Ceramic, 330uuf, 1000V	C50072-1
C69	Ceramic, .01uf 20%, 500V	C50089-3
C70	Ceramic, .001uf, 1000V	C50072-3
C71	Mylar, .022uf, 250V	C50197-49
C72	Ceramic, 900uuf 5%, 500V	CC21GP91J5
C73	Ceramic, 220uuf, 1000V	C50072-20
C74	Mylar, .047uf, 250V	C50197-52
C75	Ceramic, .01uf 20%, 500V	C50089-3
C76, 77	Ceramic, .02uf +80—20%, 500V	C50089-4
C78	Ceramic, .01uf 20%, 500V	C50089-3
C79	Ceramic, 16uuf N75, 1000V	C50070-21
C80	Electrolytic, four section: A: 10uf, 200V B: 10uf, 200V C: 30uf, 300V D: 30uf, 300V	C50180-1
C81, 82	Ceramic, .01uf 20%, 500V	C50089-3
C83	Ceramic, 16uuf N75, 1000V	C50070-21
C84, 85	Ceramic, .01uf 20%, 500V	C50089-3
C86, 87	Electrolytic, 25uf, 6V	C639-114
C88	Ceramic, .001uf, 1000V	C50072-3
C89	Mylar, .01uf, 250V	C50197-48
C92	Ceramic, .001uf, 1000V	C50072-3
C93	Mylar, .01uf, 250V	C50197-48
C94	Ceramic, 220uuf, 1000V	C50072-20
C97	Ceramic, 220uuf, 1000V	C50072-20
C98	Ceramic, .0033uf, 1000V	C50072-11
C101	Ceramic, .0033uf, 1000V	C50072-11
C102, 103	Mylar, .022uf, 250V	C50197-49
C104, 105	Ceramic, 47uuf N750, 1000V	C50070-4
C108	Mylar, .01uf, 250V	C50197-48
C110	Mylar, .01uf, 250V	C50197-48
C114	Molded, .002uf, 200V	C68P202K2
C115	Ceramic, .001uf, 1000V	C50072-3
C116	Molded, .002uf, 200V	C68P202K2
C117	Ceramic, .001uf, 1000V	C50072-3
C118, 119	Electrolytic, 25uf, 6V	C639-114
C120, 121	Ceramic, 100uuf N1500, 1000V	C50070-6
C122	Mylar, .1uf, 400V	C50197-32
C123, 124	Ceramic, 68uuf N2200, 1000V	C50070-12
C125	Mylar, .1uf, 400V	C50197-32
C126	Ceramic, 47uuf N750, 1000V	C50070-4
C127	Ceramic, 15uuf N75, 1000V	C50070-18
C128	Electrolytic, 25uf, 6V	C639-114
C129	Ceramic, 470uuf, 1000V	C50072-13
C130, 131	Mylar, .022uf, 250V	C50197-49
C132	Ceramic, 47uuf N750, 1000V	C50070-4
C133	Ceramic, 15uuf N75, 1000V	C50070-18
C134	Electrolytic, 25uf, 6V	C639-114
C135	Ceramic, 470uuf, 1000V	C50072-13
C136, 137, 138, 139	Molded, .1uf, 20%, 400V	C50197-32
C140, 141, 142, 143	Ceramic, 390uuf, 1000V	C50072-6
C144	Electrolytic, 100uf, 100V	C663-143
C145	Ceramic, 5uuf ± .5uuf N150, 500V	CC20PJ050D5
C146	Ceramic, 47uuf N750, 1000V	C50070-6
C147	Ceramic, 82uuf N1500, 1000V	C50070-7
C148	Ceramic, 68uuf N2200, 1000V	C50070-12
C149, 150	Ceramic, .005uuf 20% 500V	C50089-1
RESISTORS AND POTENTIOMETERS		
In ohms, 10% tolerance, 1/2 watt, unless otherwise noted. K = kilohm, M = megohm.		
Symbol	Description	Part No.
R1	Composition, 270	RC20BF271K
R2	Composition, 1K	RC20BF102K
R3	Composition, 4.7	RC20BF4R7K
R4, 5	Composition, 330K	RC20BF334K
R6	Composition, 100K	RC20BF104K
R7, 8	Composition, 2.2M	RC20BF225K
R9	Composition, 100	RC20BF101K
R10	Composition, 22	RC20BF220K
R11	Composition, 2.2K	RC20BF222K
R12	Composition, 47K	RC20BF473K
R13, 14	Composition, 1K	RC20BF102K
R15	Composition, 470K	RC20BF474K
R16	Composition, 1K	RC20BF102K
R17	Composition, 4.7	RC20BF4R7K
R18	Composition, 820K	RC20BF824K
R19	Wirewound, 140, 10W	R720-177
R20	Potentiometer, Wirewound, 500	R516-128
R21	Wirewound, 50, 5W	R556-142
R22	Potentiometer, Wirewound, 500	R516-128
R23	Composition, 150	RC20BF151K
R24	Composition, 150	RC20BF151K
R25	Wirewound, 220, 5W	R551-137
R26	Wirewound, 2200, 7W	R563-148
R27	Composition, 47K	RC20BF473K
R28	Wirewound, 220, 5W	R551-137
R29	Composition, 68K	RC20BF683K
R30	Composition, 1M	RC20BF105K
R31	Composition, 33K, 1W	RC30BF333K
R32	Composition, 1K	RC20BF102K

VOLTAGE MEASUREMENTS

All readings taken with vacuum-tube voltmeter (11 meg. input resistance) with respect to chassis ground, subject to 10% normal variation unless otherwise noted. Line voltage 117 vac, level controls on rear apron at MAX., Tone controls at FLAT, Selector SW at AM-FM, Filters at OFF, AM on SHARP, Stereo-Mono SW in STEREO, Balance Control at FLAT, Volume control at MIN.

SYMBOL TUBE	TUBE SOCKET PIN NUMBER								
	1	2	3	4	5	6	7	8	9
V1 $\frac{ECC85}{6AQ8}$ FM RF	184	90	0	0	6.3AC	90	-0.55	0	0
V2 $\frac{ECC85}{6AQ8}$ FM MIX OSC	164	-1.8	0	6.3AC	0	160	-3.0	0	0
V3 6AU6 1st FM IF	0	0	6.3AC	0	180	175	0.7	-	-
V4 6AU6 2nd FM IF	0	0	6.3AC	0	180	90	0.9	-	-
V5 6AU6 Limiter 300 FM IF	-0.55	0	6.3AC	0	180	65	0	-	-
V6 $\frac{EMF84}{6FG16}$ FM Tuning Eye	-0.65	NC	0	6.3AC	0	180	110	NC	110
V7 6B16 AM RF	-0.1	0.8	6.3AC	0	175	80	0	-	-
V8 ECH81/6AQ8 AM MIX OSC	80.0	0	1.3	0	6.3	180	-5.0	110	-5.0
V9 EBF89 IF Detector	85.0	0	1.55	6.3	0	180	0	1.1	0
V10 $\frac{EMF84}{6FG6}$ AM Tuning Eye	1.15	NC	1.65	6.3AC	0	180	50	NC	50
V11 $\frac{GZ34}{5AR4}$ Rect	NC	FIL	NC	AC	NC	AC	NC	400	-
V12 $\frac{EZ80}{6V4}$ Rect	AC	NC	225	FIL	FIL	NC	AC	NC	NC
V13 $\frac{7025}{ECC83}$ Pre Amp 12AX7	140	0	1.2	FIL	FIL	165	0	1.2	FIL
V14 7199 Driver Phase Inv	180	95	55	FIL	FIL	1.9	0	100	90
V15 7189 Output Audio	NC	11	23.5	FIL	FIL	NC	380	NC	320
V16 7189 Audio Output	NC	11	23.5	FIL	FIL	NC	380	NC	320
V17 $\frac{7025}{ECC83}$ Pre Amp 12AX7	120	0	1.05	23.5	12.5	100	-0.55	0	NC
V18 $\frac{7025}{ECC83}$ Pre Amp 12AX7	115	0	1.05	12	0	105	-0.65	0	NC
V19 $\frac{7025}{ECC83}$ Pre Amp 12AX7	170	0	1.2	FIL	FIL	150	0	1.2	FIL
V20 7199 Driver Phase Inv.	180	95	55	FIL	FIL	1.9	0	100	95
V21 7189 Power Amp.	NC	11	23.5	FIL	FIL	NC	380	NC	320
V22 7189 Power Amp.	NC	11	23.5	FIL	FIL	NC	380	NC	320
TERMINAL SYMBOL									
ELECTROLYTIC CAPACITOR VOLTAGE	C37	380	320	283	283	NOTES			
	C80	270	270	227	226	AC=AC volts			
	C39	214	200	185	-	NC=No connection			

R33	Composition, 1K, 1W
R34	Composition, 3.3M
R35	Composition, 22K, 1W
R36	Composition, 150
R37	Composition, 1K
R38	Composition, 270
R39	Composition, 47K
R40	Composition, 270
R41	Composition, 1K
R42	Composition, 33K
R43	Composition, 180
R44, 45	Composition, 2.2M
R46	Composition, 82K
R47	Composition, 470K
R48	Composition, 1K
R49	Composition, 47K, 1W
R50	Composition, 47K
R51	Composition, 1K
R52	Composition, 270
R53	Composition, 10M
R54	Composition, 390K
R55	Composition, 330K
R56	Composition, 470K
R57	Composition, 1K
R58	Composition, 68K
R59	Composition, 100K
R60	Composition, 3.3M
R61	Potentiometer, 250K
R62	Composition, 15K
R63	Composition, 1.5K
R64, 65	Potentiometer, 250K
R66, 67	Composition, 220K
R68, 69	Composition, 10M
R70, 71	Composition, 10M
R72	Composition, 47K
R73	Composition, 15M
R74	Composition, 2.2M
R75	Composition, 3.3M
R76	Composition, 330K, 1W
R77	Composition, 2.7K, 1W
R78	Composition, 10
R79	Composition, 330K, 1W
R80	Composition, 2.7K, 1W
R81	Composition, 10
R82	Composition, 47K
R83	Composition, 15M
R84	Composition, 2.2M
R85	Composition, 3.3M
R86	Composition, 100K
R87	Composition, 1.2K
R88	Composition, 10K
R89	Composition, 100K
R90	Composition, 10K
R91, 92	Composition, 100K
R93	Composition, 1.2K
R94	Potentiometer, Dual Bass, 1M
R95	Composition, 220K
R96	Composition, 39K
R97	Composition, 18K
R102	Composition, 220K
R103	Composition, 39K
R104	Composition, 18K
R105	Potentiometer, Dual Treble, 1M
R108, 109	Composition, 470K
R110	Composition, 10M
R111	Composition, 4.7M
R113	Composition, 10M
R114	Composition, 4.7M
R117	Composition, 10M
R119	Composition, 10M
R120, 121	Composition, 2.2M
R122, 123	Composition, 220K
R124	Composition, 2.2K
R125, 126	Composition, 100K
R127	Composition, 2.2K
R128	Potentiometer, Dual Balance, 250K
R129, 130	Composition, 47K
R131	Composition, 4.7K
R132	Potentiometer, Dual Volume, 500K
R133	Composition, 4.7K
R134, 135	Composition, 820K
R136	Composition, 220K
R137	Composition, 1.5K
R138	Composition, 100
R139	Composition, 6.8K
R140	Composition, 220K

RC30BF102K	Composition, 1.5K
RC20BF335K	Composition, 100
RC30BF223K	Composition, 6.8K
RC20BF151K	Composition, 33K, 1W
RC20BF102K	Composition, 22K
RC20BF271K	Composition, 33K, 1W
RC20BF473K	Composition, 680K
RC20BF271K	Composition, 10K
RC20BF102K	Composition, 680K
RC20BF333K	Composition, 10K
RC20BF181K	Composition, 4.7K, 1W
RC20BF225K	Composition, 1K
RC20BF823K	Composition, 15K
RC20BF474K	Composition, 1K
RC20BF102K	Composition, 4.7K, 1W
RC30BF473K	Composition, 1K
RC20BF473K	Composition, 12K,
RC20BF102K	
RC20BF271K	
RC20BF106K	
RC20BF394K	
RC20BF334K	
RC20BF474K	
RC20BF102K	
RC20BF683K	
RC20BF104K	
RC20BF335K	
R50160-3	
RC20BF153K	
RC20BF152K	

Symbol	Description	Part No.
L1	Choke, 3.3 Micro Henries	L50066-8
L2	Coil, FM Antenna	L726-124
L3	Coil, AM Antenna	L721-139
L4	AM Ferrite Loop	L721-136
L5	Choke, 1 Micro Henry	L50066-2
L6, 7	Choke, .56 Micro Henries	L50066-19
L8	Choke, RF	L629-180
L9	Coil, FM RF	L726-126
L10	Coil, FM Oscillator	L726-125
L11, 13	Choke, 1 Micro Henry	L50066-2
L12	Choke, .56 Micro Henries	L50066-19
L14,	Choke, 1.2 Micro Henries	L50066-3
15, 16,		
17, 18	Choke, Filament Ferrite Bead	L592-189
L19	Coil, AM Oscillator	L50210-21
L20	Choke, 1.2 Micro Henries	L50066-3
L21	Coil, 10kc Filter	L644-120
T1	Transformer, Power	T720-115
T2, 3	Transformer, Output	T720-116
Z1	Transformer, FM IF	ZZ662-117
Z2	Transformer, FM IF	ZZ2987
Z3	Limiter Coil Assembly	L670-145
Z4	Transformer, FM Detector	ZZ592-170
Z5	Transformer, AM RF	L556-125
Z6	Transformer, AM IF	ZZ50210-1
Z7	Transformer, AM IF	ZZ2984

Symbol	Description	Part No.
F1	Fuse, 3.2 Ampere, Slo-Blo	F3319
PC1, 2	Printed Circuit, Phono Equalization	PC50187-3
	C90, 91 390uuf 10%	
	C95, 96 560uuf 10%	
	C99, 100 1500uuf 10%	
	R98 100 270K 10%	
	R99, 101 2M 20%	
	R106, 107 120K 10%	
PC3, 4	Printed Circuit, High Frequency Filter	PC50187-2
	C106, 107 220uuf 20%	
	C109, 111, 112, 113 100uuf 20%	
	R112, 115, 116, 118 100K 20%	
11, 2	Lamp, Dial Panel	I-50082-3
S1	Switch, Selector	S720-154
S2	Switch, Mono-Stereo	S720-151
S3	Switch, Slide	S50200-2
S4	Switch, Power	Part of R132
55, 6, 7,		
8, 9	Switch, Slide	S50200-2

Symbol	Description	Part No.
—	Dress Panel, Screened	A5720-114
—	FM Dial Pointer	A720-158
—	AM Dial Pointer	A720-159
—	Knob, Tuning	E50133-1
—	Knob, Selector and Mono-Stereo	E50133-2
—	Knob, Bass and Treble, Rear	E50153-1
—	Knob, Bass and Treble, Front	E50152
—	Knob, Volume and Balance	E50154-1
—	9-Pin Tube Shield	E3287
—	7-Pin Tube Shield	E3330
—	Speaker Terminal Strip	E50170-10
—	Plastic Leg	H657-145
—	Dial Glass	N720-113
—	Fuse Holder	X1036



FISHER RADIO CORPORATION • NEW YORK

SCHEMATIC DIAGRAM • AMPLIFIER SECTION

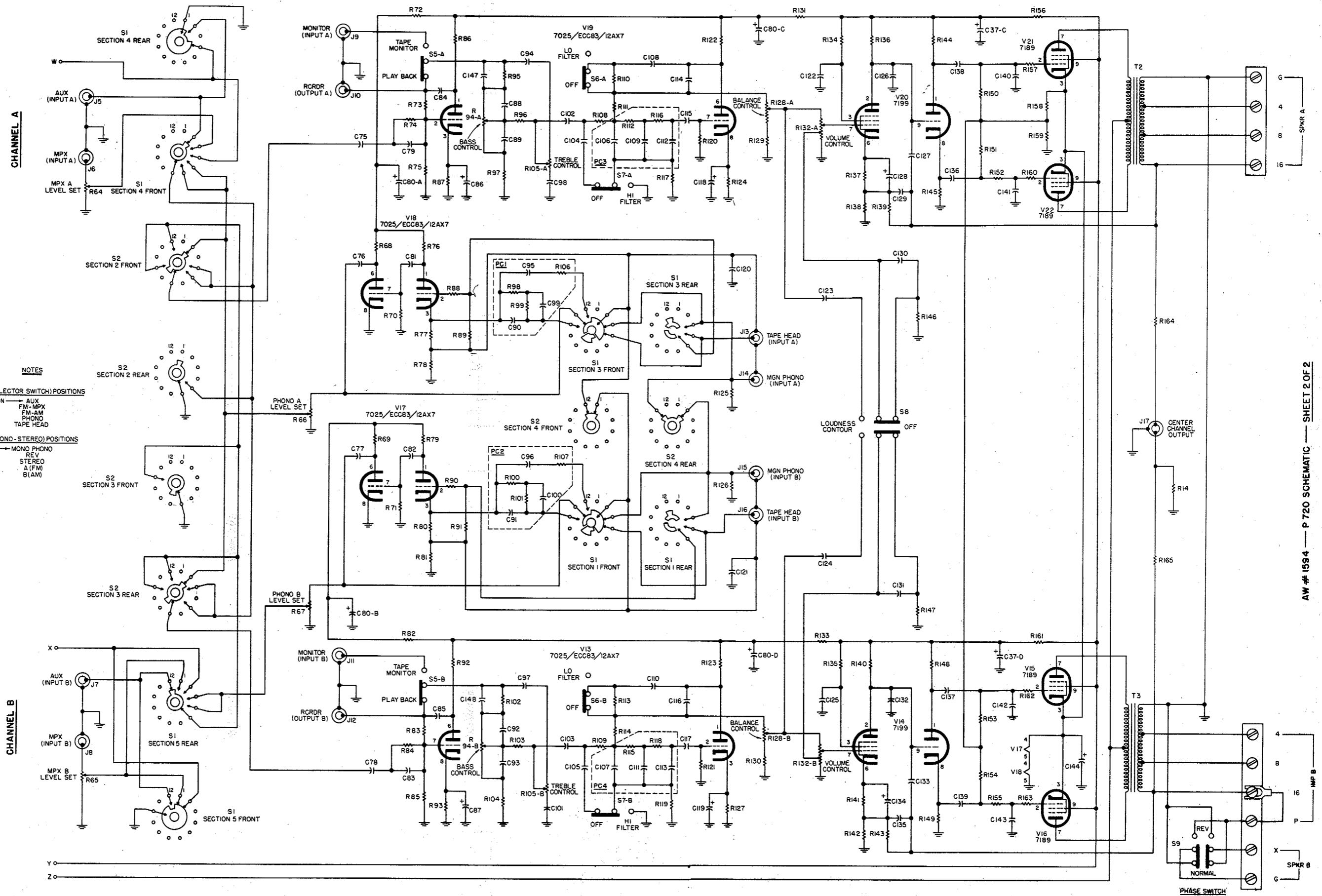

SCHEMATIC DIAGRAM • TUNER SECTION

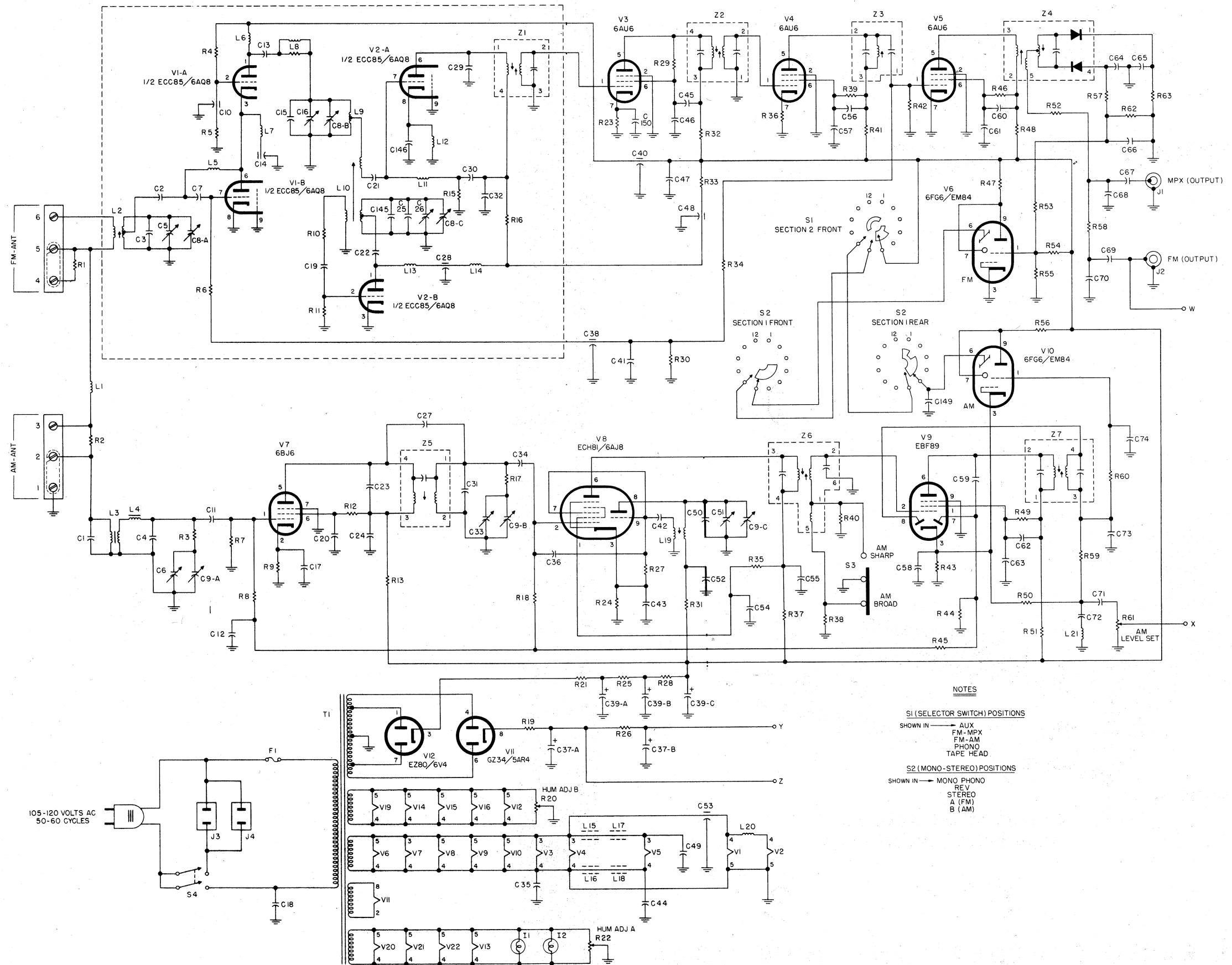

NOTES

- S1 (SELECTOR SWITCH) POSITIONS**
 SHOWN IN → AUX
 FM-MPX
 FM-AM
 PHONO
 TAPE HEAD
- S2 (MONO-STEREO) POSITIONS**
 SHOWN IN → MONO PHONO
 REV
 STEREO
 A (FM)
 B (AM)