

SERVICE MANUAL

The Fisher®

634

**4/2-Channel
Stereo Receiver**

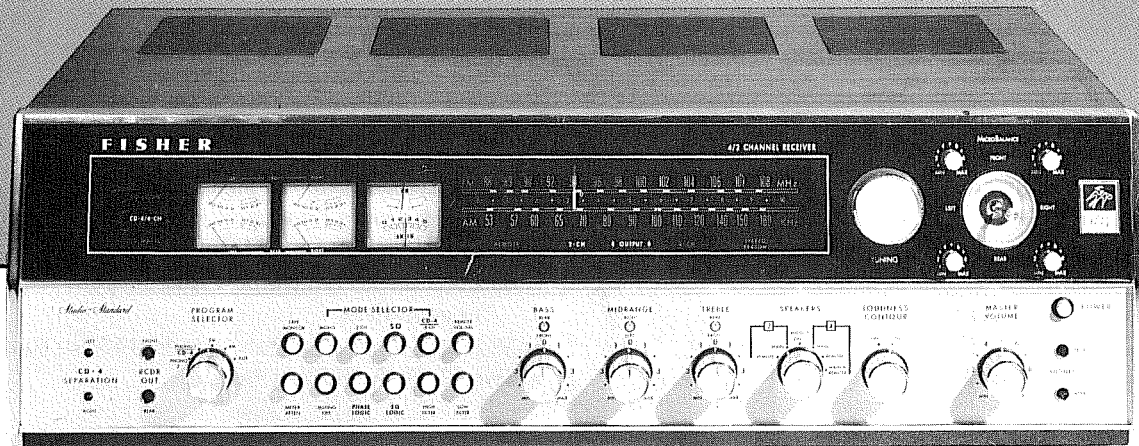

WORLD LEADER IN HIGH QUALITY STEREO

TABLE OF CONTENTS

Required Test Equipment	2
Chassis Parts List	3
Harmonic Distortion Test	3
Tuner Alignment Procedures	3,5
Tuner Schematic	4
Tuner Board Layout	5
Tuner Alignment Waveforms	6
Tuner Parts List	6,7
Tuner IC Signal Flow	8,9
Tuner IC Description	8,9
CD-4 Alignment Procedures	10
CD-4 Demodulator Board Layout	11
CD-4 Demodulator Parts List	11, 12
CD-4 Demodulator Schematic	13
Preamplifier Schematic	14
Preamplifier Parts List	14
SQ Decoder/Gain Control & Remote Control Unit Schematic	15
SQ Decoder/Gain Control & Remote Control Unit Parts List	16
Audio Control Amplifier Schematic	16
Audio Control Amplifier Parts List	16, 17
Filter Selector Board Schematic	17
Filter Selector Board Parts List	17
Audio Level Meter Board Schematic	18
Audio Level Meter Board Parts List	18
Pre-Driver/Driver and Power Module Schematic	19
Pre-Driver/Driver and Power Module Parts List	19
Speaker Selector Switch Schematic	20
Speaker Selector Switch Parts List	20
Fuse Board Schematic	21
Fuse Board Parts List	21
Speaker Protection Board Schematic	22
Speaker Protection Board Parts List	22
Dial Lamp Board Schematic	23
Dial Lamp Board Parts List	23
Power Supply Schematic	24
Power Supply Parts List	25

REQUIRED TEST EQUIPMENT

The following test equipment is required to completely test and align the Tuner section and the CD-4 Demodulator section of the Receiver:

- | | |
|--|--|
| <ul style="list-style-type: none"> ● Line Voltage Autotransformer or Voltage Regulator ● AC DC Multimeter ● Accurately Calibrated AC Voltmeter ● Oscilloscope (Flat to 100 kHz Min.) ● Low-Distortion Audio Oscillator ● Harmonic Distortion Analyzer ● CD-4 Generator (Fisher 3109 or equivalent) ● Frequency Counter | <ul style="list-style-type: none"> ● Four (4) Load Resistors, 8-ohms, 250 Watts (Minimum Rated) ● Low-Distortion AM-FM Signal Generator ● 10.7 MHz Sweep Generator, Fisher Model 3024 or equivalent ● 455 kHz Sweep Generator, Fisher Model 3025 or equivalent ● Multiplex Generator, Fisher Model 1536 or equivalent ● Two (2) RCA Shorting Plugs |
|--|--|

CAUTION: This precision high-fidelity instrument should be serviced only by qualified personnel, trained in the repair of transistorized equipment and printed circuitry.

CHASSIS PARTS LIST

Ref. Des.	Description	Part Number	Ref. Des.	Description	Part Number
—	FRONT PANEL		—	Jacks, Earphone (4)	JK20627-5
—	Jacks, (PHONES, RCDR OUT)	JK20627-5	—	Circuit Breakers, 105°C (2)	SM51486
—	Knob, TUNING	EK20060-2	—	Clamp, Antenna	EA51464
—	Knobs, (4) MICROBALANCE	EK20061-2	—	Ferrite Antenna	LA51417-3
—	Knobs, (4) PROGRAM SELECTOR, LOUDNESS CONTOUR, SPEAKERS, MASTER VOLUME	EK20066	—	Antenna Support Bracket	AB51495
—	Knobs, Top, BASS, MIDRANGE, TREBLE	EK20059-2	—	Shorting Plug Assembly	AS25020
—	Knobs, Bottom, BASS, MIDRANGE, TREBLE	EK20053	—	Terminal Board (Speakers)	ET51340-1
—	Knobs, Pushbutton	EK20046-4	—	Terminal Board (Antenna)	ET51478
—	Balance Control, 200K	RP50160-315	—	PRINTED CIRCUIT BOARDS	
—	Level Control (Microbalance), 50K	RP50160-321	—	PCB, Power Module	PM2157-1
—	Dress Panel Assembly	AS4121-140	—	PCB Fuse Board	PB2312-1
—	Window	AD23103	—	PCB, SQ Decoder and Gain Control	PB2373-1
—	Spring, Window Retainer	AN51427	—	PCB, Regulated Power Supply	PB2380-1
—	End Strip, right (Dress Panel)	AD23101-4	—	PCB, FM-AM Tuner	PB2385-5
—	End Strip, left (Dress Panel)	AD23101-2	—	PCB, Filter Selector	PB2387-1
—	Tuning Shaft Assembly	AS20734	—	PCB, Audio Level Meter	PB2388-1
—	Pointer Assembly (Plastic)	AS20512	—	PCB Audio Control	PB2392-1
—	Dial (Screened)	AS4121-108	—	PCB, Pre-Driver, Driver	PB2394-1
M1,2134	Meter, Dual Audio Level	MC2165-1	—	PCB, Pre-amplifier	PB2400-1
M,5,6	Meter, Dual (Center of Channel, Signal Strength)	MC21626-1	—	PCB Dial Lamp	PB2408-1
R123,124	Resistor, Variable, 10K (CD-4 SEPARATION)	RP50160-317	—	PCB, Speaker Protection	PB2409-1
R278,279	Resistor, 680, 5%, 1/4W	RF25DC681J	—	PCB, CD-4 Demodulator	PB2412-1
280,281	(P/O MICROBALANCE)		—	MISCELLANEOUS	
—	REAR CHASSIS		—	Drive Wheel	AM51468
—	Connector (MASTER VOLUME/BALANCE REMOTE CONTROL)	J50860	—	Selector Switch (Speakers)	SR4121-150
—	Rear Jack, Accessory Panel	JK25013	S11	Selector Switch (Program)	SR4121-151
			—	Cabinet	AS4121-136
			—	Leg, Plastic	E51172

*Export Models Only.

Note: Chassis mounted components may also be listed on the parts list of the circuit with which they function electrically.

HARMONIC DISTORTION TEST

CAUTION: Limit the following tests to no more than ten minutes each. Use 8-ohm resistors with a minimum power rating of 100 watts when connecting a load across the speaker terminals.

Control Settings: Unplug the AC power cord and set the applicable front panel controls as follows:

BASS, TREBLE, MIDRANGE, and master balance control to center positions, MICRO-BALANCE controls to MAX.

POWER pushbutton out (not depressed).

PROGRAM SELECTOR switch to AUX.

ONE CHANNEL DRIVEN:

- 1) Connect a low distortion Audio Oscillator to AUX IN FRONT LEFT jack. Set generator frequency to 1 kHz and output to minimum.
- 2) Connect an 8-ohm load resistor between FRONT SPEAKERS LEFT and COM terminals. Connect a Harmonic Distortion Analyzer and an AC VTVM in parallel across the 8-ohm load.
- 3) Connect the AC power cord and depress the POWER pushbutton. Increase MASTER VOLUME control to MAX.
- 4) Increase Audio Oscillator output to 30 watts Sine Wave Power (15.5 volts RMS across the 8-ohm load). The meter on the Harmonic Distortion Analyzer should read less than 1.0%.

REMOTE VOL/BAL pushbutton out (not depressed).

SPEAKERS switch to 4 MAIN.

MODE SELECTOR "CD-4/4-CH" pushbutton depressed.

LOUDNESS CONTOUR switch to OFF.

MASTER VOLUME control to MIN.

5) Repeat steps 1 through 4 for FRONT SPEAKERS RIGHT, REAR SPEAKERS LEFT, and REAR SPEAKERS RIGHT channels.

ALL CHANNELS DRIVEN:

- 1) Connect an 8-ohm load resistor across each of the SPEAKER output terminals.
- 2) Depress the MODE SELECTOR "MONO" pushbutton.
- 3) Check for distortion of 1.0% or less at 30 watts Sine Wave Power (15.5 volts RMS) on each channel with all channels driven simultaneously.
- 4) Disconnect all test equipment.

TUNER ALIGNMENT PROCEDURES

FM ALIGNMENT – BASS, TREBLE, MIDRANGE, and all balance controls to center positions, SPEAKERS switch to PHONES ONLY position, MODE SELECTOR "2-CH" pushbutton depressed, PROGRAM SELECTOR switch to FM position, MASTER VOLUME control to MIN position and POWER pushbutton depressed (power on).

Maintain generator output as low as possible for suitable indication.

ITEM	GENERATOR	DIAL SETTING	INDICATOR	PROCEDURE
Note: The FM IF circuit utilizes a non-tunable ceramic filter which establishes the IF bandpass. To ensure symmetrical tuning and selectivity, the IF must be aligned precisely to the center of the filter bandpass, rather than to 10.7 MHz as in conventional LC circuits.				
1. FM IF ALIGNMENT	Connect 10.7 MHz Sweep Generator to pin 63, ground to pin 5Y. Markers are not required. Set generator output to -10 dB (300 mV).	Position of non-interference. Connect jumper from pin 26 to pin 5R on Tuner board.	Scope vertical input to pin 57, ground to pin 5U. Set vertical sensitivity to 0.5 V/cm.	Adjust Z502 top and bottom slugs for maximum gain and best symmetry. See figure for FM IF ALIGNMENT.
2. PRELIMINARY FM DETECTOR ALIGNMENT	Same as above. Adjust for S-curve display. Generator output to -20 dB.	Position of non-interference.	Scope vertical input to pin 58, ground to pin 5K.	Adjust Z503 top slug for maximum gain and best linearity. Adjust Z503 bottom slug for minimum gain and best linearity. See figure for FM DETECTOR ALIGNMENT. Remove jumper from between pins 26 and 5R on Tuner board.
Note: Connect 120-ohm composition resistors in series with each lead from the FM generator to match the 50-ohm output to the 300 ohm receiver input impedance. Generator output voltage is reduced to one-half at antenna terminals. Signal voltages specified in this table are generator output levels, not antenna voltages.				
3. FRONT END FM ALIGNMENT		Tuning knob fully counterclockwise.		Center dial pointer on "0" and cement.
4.	Connect FM generator to FM ANT terminals through 120-ohm resistors. Set to 90 MHz. Adjust output for approximately 2 on signal strength meter (M4).	Center of 90 MHz calibration mark on dial.	Front panel signal strength meter (M6).	Adjust L504, L502, and Z501 for maximum deflection on signal strength meter (M6). Reduce generator output to keep meter indication at approximately 2.
5.	Set to 106 MHz.	Center of 106 MHz calibration mark on dial.	Front panel signal strength meter (M6).	Adjust C503, C509, and C518 for maximum deflection on signal strength meter (M6). Reduce generator output to keep meter indication at approximately 2. Repeat steps 4 and 5 for optimum alignment.
6. FINAL FM DETECTOR ALIGNMENT (MINIMUM THD)	Set generator to receiver frequency. Modulate with 400 Hz ± 75 kHz deviation. Connect generator to FM ANT terminals.	Tune receiver to position of non-interference.	Scope vertical input to OUT TO RECORDER FRONT LEFT jack on rear panel.	Reduce generator output for noise to be visible on sine wave. Readjust generator frequency to center noise on positive and negative half cycles. See figure for SYMMETRICAL TUNING response. Note: Do not change generator or receiver tuning. Proceed with step 7.

TUNER SCHEMATIC

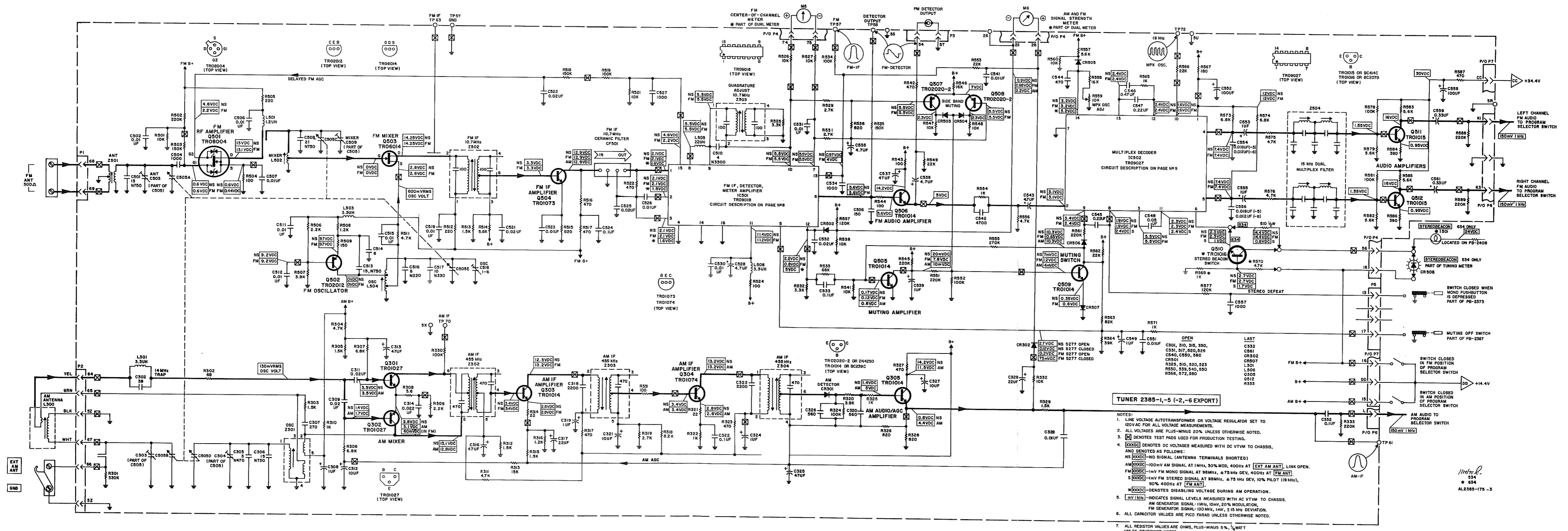

TUNER 2385-1, -5 (-2, -6 EXPORT)

- 1. LINE VOLTAGE AUTOTRANSFORMER OR VOLTAGE REGULATOR SET TO 120VAC FOR ALL VOLTAGE MEASUREMENTS.
- 2. ALL VOLTAGES ARE PLUS-MINUS 20% UNLESS OTHERWISE NOTED.
- 3. \square DENOTES TEST PADS USED FOR PRODUCTION TESTING.
- 4. \square DENOTES DC VOLTAGES MEASURED WITH DC VTVM TO CHASSIS, AND DENOTES AS FOLLOWS:
 - NS \square NO SIGNAL (ANTENNA TERMINALS SHORTED)
 - AM \square 100-mV AM SIGNAL AT 1MHz, 30% MOD, 400Hz AT [EXT AM ANT], LINK OPEN.
 - FM \square 1-mV FM MONO SIGNAL AT 98MHz, ± 75 Hz DEV, 10% PILOT (19 kHz), 90% 400Hz AT [FM ANT].
 - S \square 1-mV FM STEREO SIGNAL AT 98MHz, ± 75 Hz DEV, 10% PILOT (19 kHz), 90% 400Hz AT [FM ANT].
 - DENOTES DISABLING VOLTAGE DURING AM OPERATION.
- 5. [mV] [MHz] - INDICATES SIGNAL LEVELS MEASURED WITH AC VTVM TO CHASSIS. AM GENERATOR SIGNAL: 1MHz, 10mV, 20% MODULATION, FM GENERATOR SIGNAL: 100MHz, 1mV, ± 15 kHz DEVIATION.
- 6. ALL CAPACITOR VALUES ARE PICO FARAD UNLESS OTHERWISE NOTED.
- 7. ALL RESISTOR VALUES ARE OHMS, PLUS-MINUS 5%, 1/4WATT UNLESS OTHERWISE NOTED.

INT'L
534
534
AL2385-175 -3

TUNER ALIGNMENT PROCEDURES (CONT'D.)

ITEM	GENERATOR	DIAL SETTING	INDICATOR	PROCEDURE
7.	Same as step 6. Increase generator output to 2 mV.	Same as step 6.	AC VTVM and Harmonic Distortion analyzer to OUT TO RECORDER-FRONT LEFT jack on rear panel.	Adjust Z503 top slug for center indication on Center of Channel Meter (M5). Adjust bottom slug for minimum THD. (Typically 0.2%).
8A. MPX OSC ADJUSTMENT	Same as step 7.	Tune receiver to FM signal generator frequency.	Connect frequency counter to pin 72.	Adjust R559 for indication of 19 kHz (± 100 Hz).
8B. ALTERNATE MPX OSC ADJUSTMENT	Same as step 7.	Same as step 8A.	Scope vertical input to pin 72. Scope horizontal input to MPX generator 19 kHz pilot output.	Adjust R559 for a stable Lissajou display as shown in the figure for MPX OSC ALIGNMENT.

AM ALIGNMENT – BASS, TREBLE, MIDRANGE, and all balance controls to center positions, SPEAKERS switch to PHONES ONLY position, MODE SELECTOR "2-CH" pushbutton depressed, PROGRAM SELECTOR switch to AM position, MASTER VOLUME control to MIN position, and POWER pushbutton depressed (power on).

Maintain generator output as low as possible for suitable indication.

ITEM	GENERATOR	DIAL SETTING	INDICATOR	PROCEDURE
1. AM IF ALIGNMENT	455 kHz sweep generator to pin 70, ground to pin 5X.	Position of non-interference near 1400 kHz.	Scope vertical input to pin 61 ground to pin 5X. Set vertical sensitivity to 0.2 V/cm.	Connect a jumper between pin 67 and pin 5Z. Adjust Z302, Z303, and Z304 top and bottom slugs for maximum gain and best symmetry. Keep signal low enough for noise to appear on response as shown in the figure for AM IF ALIGNMENT. Disconnect jumper.
2. FRONT END AM ALIGNMENT	Open GND link. AM generator to EXT AM ANT and GND terminals on rear panel of receiver. Set to 600 kHz. Modulate with 400 Hz, 30% modulation.	Center of 600 kHz calibration mark on dial.	Front panel signal strength meter (M6).	Adjust Z301 and L300 (antenna) for maximum signal meter indication. Reduce generator output to keep meter reading below 3.
3.	Set to 1400 kHz.	Center of 1400 kHz calibration mark on dial.	Front panel signal strength meter (M6).	Adjust C303 and C304 for maximum deflection. Keep meter reading below 3. Repeat steps 2 and 3 until optimum alignment is reached.

TUNER BOARD LAYOUT

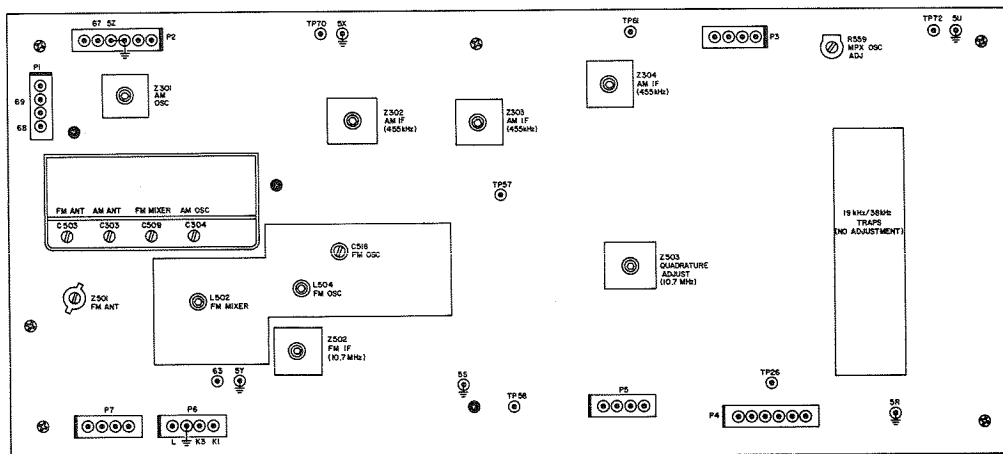

NOTE: CHASSIS GROUNDS ARE COMPLETED THROUGH MOUNTING SCREWS (⊙). TIGHTEN BEFORE ATTEMPTING ALIGNMENT.

AL 2385 - 177

TUNER ALIGNMENT WAVEFORMS

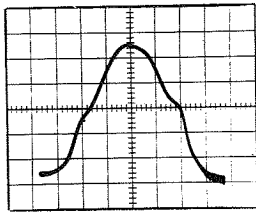

FM IF ALIGNMENT

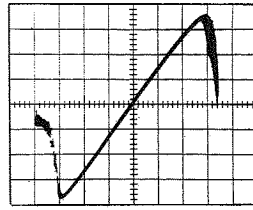

FM DETECTOR ALIGNMENT

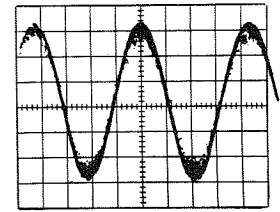

SYMMETRICAL TUNING

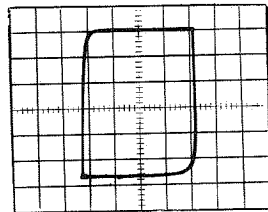

MPX OSC ADJUSTMENT

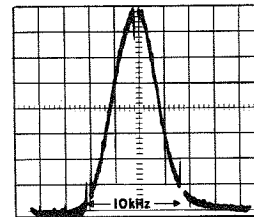

AM IF ALIGNMENT

TUNER PARTS LIST

Ref. Des.	Description	Part Number	Ref. Des.	Description	Part Number
C302	Ceramic, 39pF, N330, 50V	CK22344-2	C509	P/O C505	
C303, 304	P/O C505		C510	Tubular, 4pF, ± 0.25 pF, N3300	CT22336-11
C305	Ceramic, 3pF, ± 0.25 pF, N470	CK22346-4	C514	Ceramic, 8pF, 5%, NPO, 50V	CK22344-5
C306, 501, 513	Ceramic, 15pF, 5%, N750, 50V	CK22344-2	C516	Ceramic, 8 N220, 5%	CT22336-13
C307	Ceramic, 270pF, 10%, 50V	CK22350-5	C517	Ceramic, 10 N330, 5%	CT22336-14
C308, 319, 324, 539, 549, 553, 555	Electrolytic, 1uF, 50V	CE22342-2	C518	Trimmer, 1-6pF	C50B938-5
C309, 311, 521, 522, 525, 532	Ceramic, 0.02uF, +80 -20%, 50V	CK22354-2	C528, 535, 538, 543	Electrolytic, 4.7uF, 50V	CE22342-3
C312, 321, 327	Electrolytic, 10uF, 50V	CE22342-4	C536	Ceramic, 150pF, 10%, 50V	CK22350-2
C313, 316, 325, 537	Electrolytic, 47uF, 16V	CE22342-8	C542	Ceramic, 4700pF, 10%, 50V	CK22347-22
C314	Mylar, 0.022uF, 10%, 50V	CY22356-9	C544	Silvered Mica, 470pF, 5%, 50V	CA22313-1
C317, 329	Electrolytic, 22uF, 35V	CE22342-6	C545	Mylar, 0.22uF, 10%, 250V	C50575-2
C318, 323	Polystyrene, 2200pF, 5%, 33V	C51256-30	C546	Sintered Aluminum, 0.47uF, 20%	CS22340-4
C320, 326	Ceramic, 560pF, 10%, 50V	CK22350-9	C547	Mylar, 0.22uF, 10%, 50V	CY22356-12
C322, 524, 533	Ceramic, 0.1uF, +80 -20%, 50V	CK22354-3	C548	Polyester, 0.05uF, 10%, 100V	CY22335-5
C328, 502, 506, 507, 511, 512, 515, 519, 523, 526, 530, 531, 541, 551	Ceramic, 0.01uF, +80 -20%, 50V	CK22354-1	C552	Electrolytic, 100uF, 16V	CE22342-12
C332	Mylar, 0.1uF, 10%, 50V	CY22356-11	C554, 556	Polyester, 10%, 0.018uF, 100V	CY22335-10
C503	P/O C505		C558	Electrolytic, 100uF, 35V	CE22342-10
C504, 527, 534, 557	Ceramic, 1000pF, 10%, 50V	CK22350-12	C559, 561	Tantalum, 0.33uF, 35V	CL22305-9
C505A, B, C, D, E	Tuning Gang Assembly	CV21015	CF501	Filter, ceramic, 10.7 MHz	ZK22110
C508	Ceramic, 21pF, 10%, N750, 50V	CK22345-15	CR301, 502	Diode, Germanium (AA119)	TR12001-4
			CR302, 503, 504, 505, 506, 507	Diode, Silicon	TR13006-2
			IC501	I.C., FM IF	TR09018
			IC502	I.C., MPX Decoder	TR09027
			L301, 503, 506	Choke, 3.3uH	LC21814-2
			L501	Choke, 1.2uH	LC21822-2
			L502	Coil, FM Mixer	LC21833-2
			L504	Coil, FM Oscillator	LC21833-1
			L505	Choke, 22uH	LC50848-18

TUNER PARTS LIST (CONT'D.)

Ref. Des.	Description	Part Number	Ref. Des.	Description	Part Number
Q301, 302	Transistor, NPN (A494/BF194)	TR01027	R326, 820		RF25DC821J
Q303,	Transistor, NPN (BC239C)	TR01014	328, 515,		
305, 505,			536		
506, 509			R331, 100		RF25DC101J
Q304	Transistor, NPN (BF199)	TR01074	504, 524,		
Q501	Transistor, Dual-Gate MOSFET	TR08004	543, 544		
Q502	Transistor, PNP (SP871)	TR02012	R332, 10K		RF25DC103J
Q503	Transistor, N-Channel FET	TR06014	501, 521,		
Q504	Transistor, NPN (BF198)	TR01073	526, 527,		
Q507,	Transistor, PNP (2N4250)	TR02020-2	538, 541,		
508			547, 548,		
Q510	Transistor, NPN (BC207B)	TR01016	560		
Q511,	Transistor, NPN (BC414C)	TR01015	R333, 220K		RF25DC224J
512			502, 545,		
R301	330K	RF25DC334J	551, 561,		
R302	68	RF25DC680J	588, 589		
R303,	1.5K	RF25DC152J	R503, 150K		RF25DC154J
305, 312,			518, 535		
315, 329,			R505, 220		RF25DC221J
513			512		
R304,	4.7K	RF25DC472J	R509 150		RF25DC151J
311, 511,			R514, 5.6K		RF25DC562J
556, 570,			528, 579,		
575, 576			582, 583,		
R306,	6.8K	RF25DC682J	585		
307, 573,			R525, 3.3K		RF25DC332J
574			532		
R308	5.6	RF25DC5R6J	R533 68K		RF25DC683J
R309,	2.2K	RF25DC222J	R537, 120K		RF25DC124J
506			577		
R310,	1K	RF25DC102J	R546, 16K		RF25DC163J
322, 554,			558		
565, 571			R549, 22K		RF25DC223J
R313	15K	RF25DC153J	553, 562,		
R314,	22	RF25DC220J	566		
321			R555 270K		RF25DC274J
R316,	1.2K	RF25DC122J	R559 Variable 10K, 20%		RV50150-23-7
508			R563 82K		RF25DC823J
R317,	470	RF25DC471J	R564 39K		RF25DC393J
323, 327,			R567 180		RF25DC181J
516, 517,			R584, 390		RF25DC391J
522, 542,			586		
587			R590 270		RF25DC271J
R318	8.2K	RF25DC822J	Z301 Coil, AM Oscillator		ZZ50210-181
R319,	2.7K	RF25DC272J	Z302 Transformer, IF Input		ZZ50210-161
529, 531			Z303 Transformer, IF Interstage		ZZ50210-156
R320,	3.9K	RF25DC392J	Z304 Transformer, IF Output		ZZ50210-159
507			Z501 Coil, FM Antenna		LC21832
R324,	100K	RF25DC104J	Z502 Transformer, 10.7 MHz IF		ZZ50210-146
330, 519,			Z503 Transformer, FM IF		ZZ50210-180
534, 552			Z504 15KHz Dual Multiplex Filter		ZZ50210-190

All resistors are deposited film, 5%, 1/4W unless otherwise noted. K = Kiloohm

TUNER IC SIGNAL FLOW

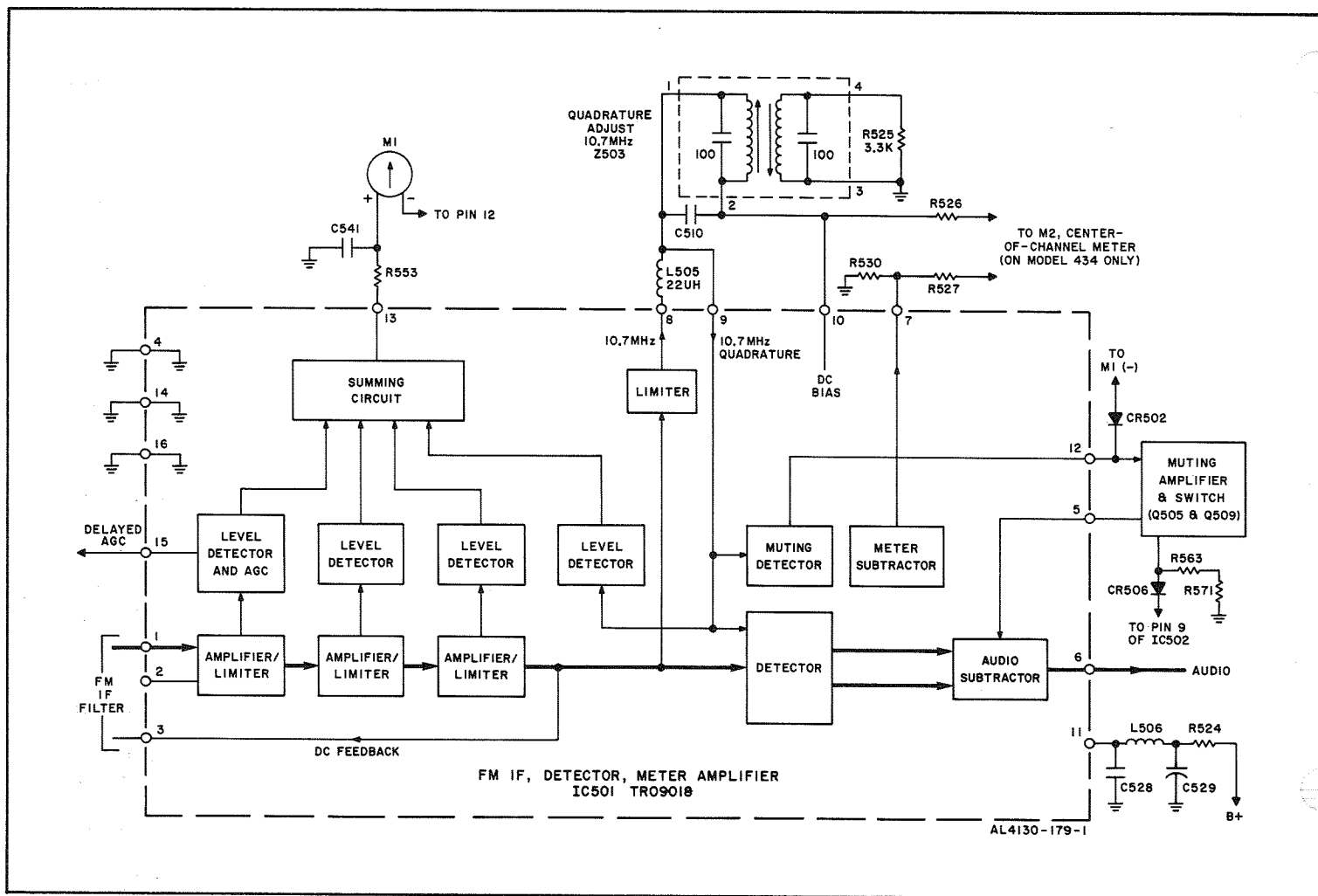

TUNER IC DESCRIPTION

IF DETECTOR IC

The input from the IF filter is processed through three stages of amplification and limiting. The output of the third limiter is applied to a fourth limiter, and a balanced detector. The push-pull output from the detector is combined differentially in the subtractor stage to produce an audio output at pin 6.

The output from the fourth limiter is applied through L505 to tuned circuit Z503. At the exact center of the IF passband (nominally 10.7 MHz), Z503 is preset to provide a 10.7 MHz quadrature (90 degrees out-of-phase) signal to the detector. The phase of the signal from the tuned circuit changes proportionally with changes in the frequency of the IF signal. With no audio modulation, the inputs of the detector are in quadrature and the outputs of the detector are balanced. No differential signals appear at the outputs of the subtractor stages. When the frequency of the IF signal deviates from 10.7 MHz (as a result of audio modulation or station detuning), the de-

tor outputs are unbalanced and a differential DC signal appears at pin 6.

The muting detector (pin 12) monitors the envelope signal-to-noise ratio across the tuned circuit and feeds the detected noise to the muting amplifier and switch. Excessive noise in the signal generates a control voltage which is amplified and applied to pin 9 of IC502 to force the receiver into monophonic operation.

Level detectors monitor the IF signal levels at the three amplifier/limiter stages and at the tuned circuit. Each limiter, beginning with the last, saturates progressively as the input level increases. Rectified signals from the level detectors are summed and applied (pin 13) as a linear-log voltage to the signal strength meter.

An AGC voltage (pin 15) for the RF amplifier is obtained from the first level detector. This AGC voltage is delayed until the IF signal in the first amplifier approaches limiting.

TUNER IC SIGNAL FLOW

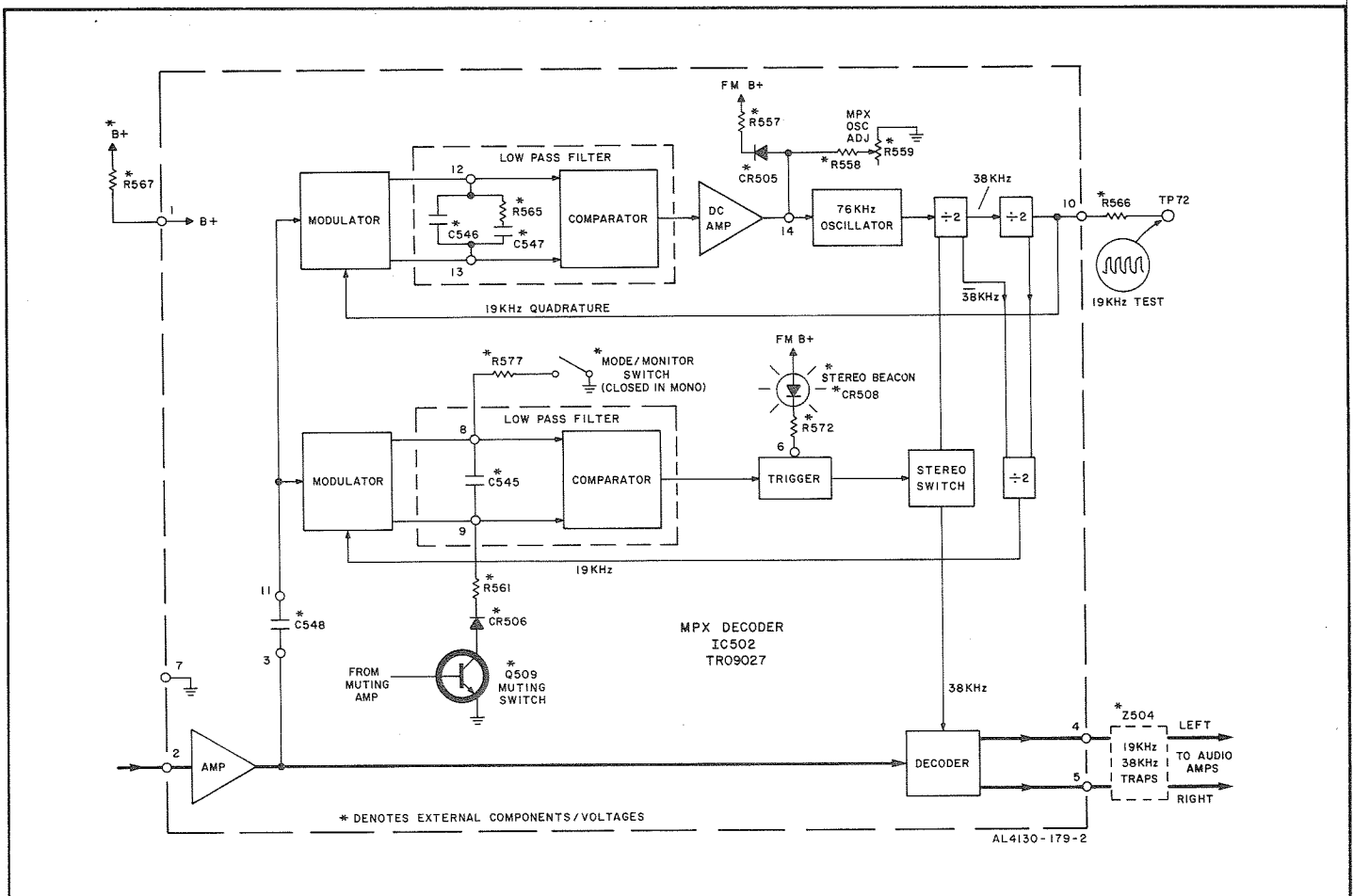

TUNER IC DESCRIPTION

MPX DECODER IC

When the receiver is tuned to a stereo broadcast the composite audio fed to pin 2 consists of sum-and-difference signal information (L + R and L - R), and a 19 kHz pilot tone. The L + R information is in the form of normal audio. The L - R information is Amplitude Modulated on a suppressed 38 kHz sub-carrier. (At the transmitter, the subcarrier is derived from the pilot tone through a frequency-doubler.) In order to extract the L - R information, it is necessary to regenerate the 38 kHz subcarrier and apply it, together with the composite signal, to the decoder. Left and Right channel information is then decoded by addition and subtraction of the L + R and L - R information.

The top line of the block diagram shows the 38 kHz subcarrier regeneration loop. The 76 kHz oscillator output is processed through two frequency divider stages to furnish 38 kHz and 19 kHz outputs. The 19 kHz output is a quadrature (90° out-of-phase) signal which is applied to the modulator. When the composite input signal contains a 19 kHz pilot tone (stereo broadcast) the 19 kHz quadrature signal is phase-compared to the pilot signal and the resulting DC voltage fed through the DC amplifier to the oscillator, where it corrects the frequency. As a

result, the oscillator is continuously phase-locked to the pilot signal. The setting of R559 determines the frequency of the free-running oscillator. With the oscillator phase-locked to the pilot, the 38 kHz output from the first divider is in the correct phase for decoding a stereo signal. The regenerated 38 kHz signal is fed to the decoder via a stereo switch. The stereo switch closes when a sufficiently large 19 kHz pilot tone is detected in the second modulator-comparator circuit. A third frequency divider stage, which processes signals derived from the first two dividers, returns a 19 kHz in phase signal to the second modulator-comparator for pilot detection. The DC voltage derived from the second modulator-comparator circuit is applied to the trigger which activates the STEREO-BEACON indicator and the stereo switch.

The circuit is forced into the monophonic mode by grounding pin 8, or by applying a positive DC voltage to pin 9. With very low-level, noisy FM signals, a positive voltage from pin 12 of IC501 is amplified without change of polarity and applied to pin 9 of IC502 forcing the circuit into mono operation. During AM operation pin 14 is effectively grounded thus disabling the 76 kHz oscillator and eliminating interference.

CD-4 ALIGNMENT PROCEDURES

APPLICABLE CONTROL SETTINGS – Set the applicable controls on the front panel of the 634 receiver as follows:

PROGRAM SELECTOR switch to PHONO-1/CD-4, **MODE SELECTOR** CD-4/4-CH pushbutton depressed, and **MASTER VOLUME** control to MIN.

ITEM	TEST CONNECTIONS	INDICATOR	PROCEDURE
1. ANRS ALIGNMENT	Connect audio oscillator to TP 5 on PB2412 circuit board. Set oscillator output to 25 mV and frequency to 10 kHz.	AC VTVM to OUT TO RECORDER - FRONT LEFT jack on receiver's rear panel.	Defeat the muting circuit by grounding TP 1 on PB2412 circuit board. Set LEFT and RIGHT CD-4 SEPARATION controls (R123 and R124) at front panel of receiver to minimum (fully counterclockwise). Adjust R183 for 17.5 mV reading on the meter.
2.	Connect audio oscillator to TP 4 on PB2412 circuit board. Set oscillator output to 25 mV and frequency to 10 kHz.	AC VTVM to OUT TO RECORDER - FRONT RIGHT jack on receiver's rear panel.	Adjust R184 for a reading of 17.5 mV on the meter.
3. VCO ALIGNMENT	Connect oscilloscope and frequency counter to TP 3 on PB2412 circuit board.	Scope display will be a triangular waveform 400 mV peak-to-peak.	Retain the ground connection made in step 1 to defeat the muting circuit. Using two RCA shorting plugs, short out PH 1/CD-4 LEFT and RIGHT jacks. Adjust R159 for a 30 kHz \pm 200 Hz indication on the frequency counter
4.	Connect oscilloscope and Frequency counter to TP 2 on PB2412 circuit board.	Scope display will be a triangular waveform 400 mV peak-to-peak.	Adjust R164 for a 30 kHz \pm 200 Hz indication on the frequency counter.
Note: Remove ground connection from TP 1 (muting circuit) and remove shorting plugs from PH 1/CD-4 IN jacks.			
5. SEPARATION ALIGNMENT	Connect CD-4 Generator to PH 1/CD-4 IN LEFT and RIGHT jacks on rear panel of receiver. Set generator output as follows: Sub-Channel carrier level . . . 1.5 mV Channel Selector FRONT Deviation 2.2 kHz Base Channel 2.5 mV Input Frequency 1 kHz Delay 40 usec.	Connect AC VTVM to OUT TO RECORDER - REAR LEFT jack on rear panel of receiver. CD-MATIC indicator lamp on front panel of receiver should be illuminated.	Adjust LEFT CD-4 SEPARATION control (R123) at receiver front panel for minimum reading on the meter.
6.	Same as step 5.	Connect AC VTVM to OUT TO RECORDER - REAR RIGHT jack on rear panel of receiver.	Adjust RIGHT CD-4 SEPARATION control (R124) at receiver front panel for minimum reading on the meter.
7. LEFT CHANNEL SEPARATION	Connect AC VTVM to OUT TO RECORDER - FRONT LEFT jack on rear panel of receiver.	AC VTVM	Meter reading should be 500 mV \pm 150 mV. Record this reading as zero dB.
8.	Connect AC VTVM to OUT TO RECORDER - REAR LEFT jack on rear panel of receiver.	AC VTVM	Meter reading should be at least 20 dB below zero dB reading recorded in step 7.
9. RIGHT CHANNEL SEPARATION	Connect AC VTVM to OUT TO RECORDER - FRONT RIGHT jack on rear panel of receiver.	AC VTVM	Meter reading should be 500 mV \pm 150 mV. Record this reading as zero dB.
10.	Connect AC VTVM to OUT TO RECORDER - REAR RIGHT jack on rear panel of receiver.	AC VTVM	Meter reading should be at least 20 dB below zero dB reading recorded in step 9.

CD-4 DEMODULATOR BOARD LAYOUT

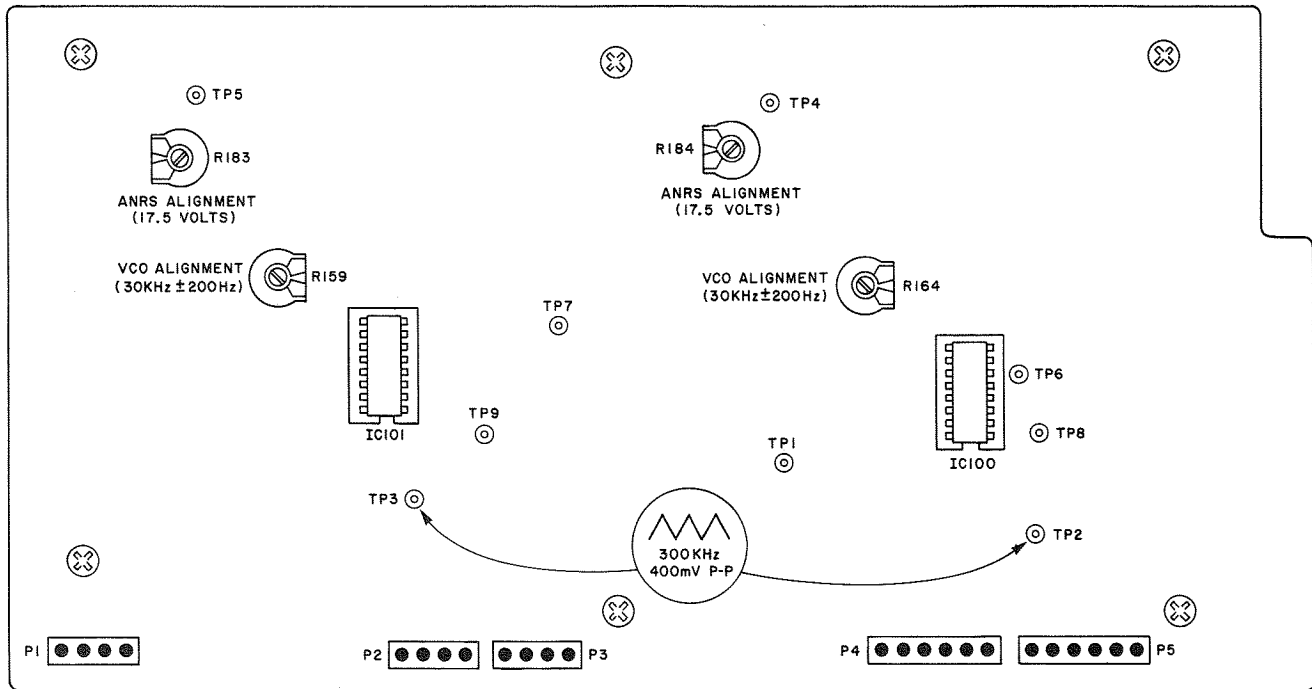

AL4134-177-1

CD-4 DEMODULATOR PARTS LIST

Ref. Des.	Description	Part Number	Ref. Des.	Description	Part Number
C100, 101, 174, 175	Tantalum, 0.68uF, 35V	CL22305-2	C144, 145	Mylar, 0.012, 10%, 100V	CY22335-10
C102, 103	Tantalum, 10uF, 25V	CL22305-17	C146, 147, 203, 204, 215, 216	Sintered Aluminum, 0.47uF, 25V	CS22340-4
C104, 105	Mylar, 5000pF, 5%	CY22356-28	C150, 151, 166, 167, 170, 171, 213, 218	Mylar, 0.022, 10%, 100V	CY22335-12
C106, 107	Ceramic, 5pF, 5% NPO, 50V min.	CK22344-1	C152, 153	Mylar, 0.0068, 10%, 100V	CY22335-9
C108, 109	Tantalum, 2.7uF, 35V	CL22305-4	C154, 155	Mylar, 0.1, 10%, 100V	CY22335-18
C110, 114, 208	Electrolytic, 100uF, 16V	CE22342-12	C156, 157, 209, 211, 212, 214	Sintered Aluminum, 1uF, 25V	CS22340-6
C111	Electrolytic, 200uF, 16V	CE22342-15	C160, 161	Electrolytic, 4.7uF, 50V	CE22342-3
C112, 113, 120, 121, 129, 130, 131, 132, 158, 159, 180, 181, 182, 183, 207, 210	Ceramic, 1000pF, 10%, 50V	CK22350-12	C162, 163, 178, 179	Mylar, 0.0082, 10%, 100V	CY22335-25
C115, 116, 137, 138, 168, 169	Mylar, 0.0012, 10%, 100V	CY22335-23	C164, 165	Mylar, 0.047, 10%, 100V	CY22335-22
C117, 124	Mylar, 0.0015, 10%, 100V	CY22335-24	C172, 173, 192	Electrolytic, 10uF, 25V	CE22342-28
C118, 119	Mylar, 0.0033, 10%, 100V	CY22335-7	C176, 177	Mylar, 0.15, 10%, 100V	CY22335-19
C122, 123, 125, 126, 142, 143, 148, 149	Sintered Aluminum, 4.7uF, 25V	CS22340-6	C184, 185, 186, 187	Mylar, 0.0039, 10%, 100V	CY22335-4
C128	Electrolytic, 100uF, 35V	CE22342-10	C193, 194	Sintered Aluminum, 2.2uF, 25V	CS22340-10
C133, 134, 139, 140, 188, 189, 190, 191	Mylar, .01, 10%, 100V	CY22335-1	C195, 196	Mylar, .015, 10%, 100V	CY22335-2
C135, 136	Ceramic, 330pF, 10%, 50V	CK22350-6	C197, 198	Mylar, 0.033, 10%, 100V	CY22335-14
			C199, 200, 201, 202	Ceramic, 560pF, 10%, 50V	CK22350-9
			C205, 206	Mylar, 0.039, 10%, 100V	CY22335-15
			CR100	Silicon Diodes	TR13006-2
			through		
			CR106,		
			CR108		

CD-4 DEMODULATOR PARTS LIST (CONT'D.)

Ref. Des.	Description	Part Number	Ref. Des.	Description	Part Number
L100 through L105	Inductor, audio, 22mH	LC21834-2	R130, 161, 166, 206, 218, 243, 252	2.2K	RF25DC222J
L106, 107	Inductor, audio, 160mH	LC21834-1	R135, 142,	3.9K	RF25DC392J
IC100, 101	CD-4 IC Demodulator	TR09035	147, 160, 201, 204, 225, 230, 239, 246		
Q102, 103, 114, 115	Transistor, PNP (2N4250)	TR02020-2			
Q104, 105	Transistor, NPN	TR01015			
Q106 - through 113, 116 through 124	Transistor, (BC239C)	TR01014	R136, 138	47K	RF25DC473J
Q126	Transistor, NPN	TR01053-5	223, 234		
R100, 101, 167, 174	1K	RF25DC102J	R139, 148,	1.2K	RF25DC122J
R102, 103	1M	RF25DC105J	199, 200, 241, 250		
R104, 105	120K	RF25DC124J	R143, 144,	2.7K	RF25DC272J
R106, 107, 215, 222	82K	RF25DC823J	227, 232		
R108, 109	820	RF25DC821J	R145, 150,	5.6K	RF25DC562J
R110, 249, 251, 257, 258	100K	RF25DC104J	173, 176, 191, 192, 197, 198		
R111, 114, 115, 121, 122, 137, 141, 146, 152, 171, 172, 255	10K	RF25DC103J	R149, 156,	220K	RF25DC224J
R112, 113	820K	RF25DC824J	157, 162		
R116, 117, 131, 132, 133, 140, 177, 181, 182, 189, 190, 193, 194, 195, 196, 260	56K	RF25DC563J	R151, 153, 154, 158, 209, 212, 213, 216, 221, 228, 207, 210, 211, 214, 219, 220, 226, 245, 247, 254, 256	3.3K	RF25DC332J
R118, 119	1.8K	RF25DC182J	R159, 164	Resistor, variable, 100K	RV50150-23-8
R120, 126	82, 1/2W	RF50DC820J	R165, 170	1.5M	RF25DC155J
R123, 124	Variable, 10K	RP50160-317	R168, 169	330	RF25DC331J
R127, 128, 229, 231, 236, 238	100	RF25DC101J	187, 188		
R129, 134, 185, 186	22K	RF25DC223J	R175, 178, 179, 180	39K	RF25DC393J
			R183, 184	Resistor, variable, 10K	RV50150-23-7
			R202, 203	390	RF25DC391J
			R205, 208	12K	RF25DC123J
			R217, 224	18K	RF25DC183J
			R233, 235, 240, 242	1.5K	RF25DC152J
			R237, 244	8.2K	RF25DC822J
			R248	470	RF25DC471J

All resistors are deposited film, 5%, 1/4W unless otherwise noted. K = Kilohm; M = Megohm.

CD-4 DEMODULATOR SCHEMATIC

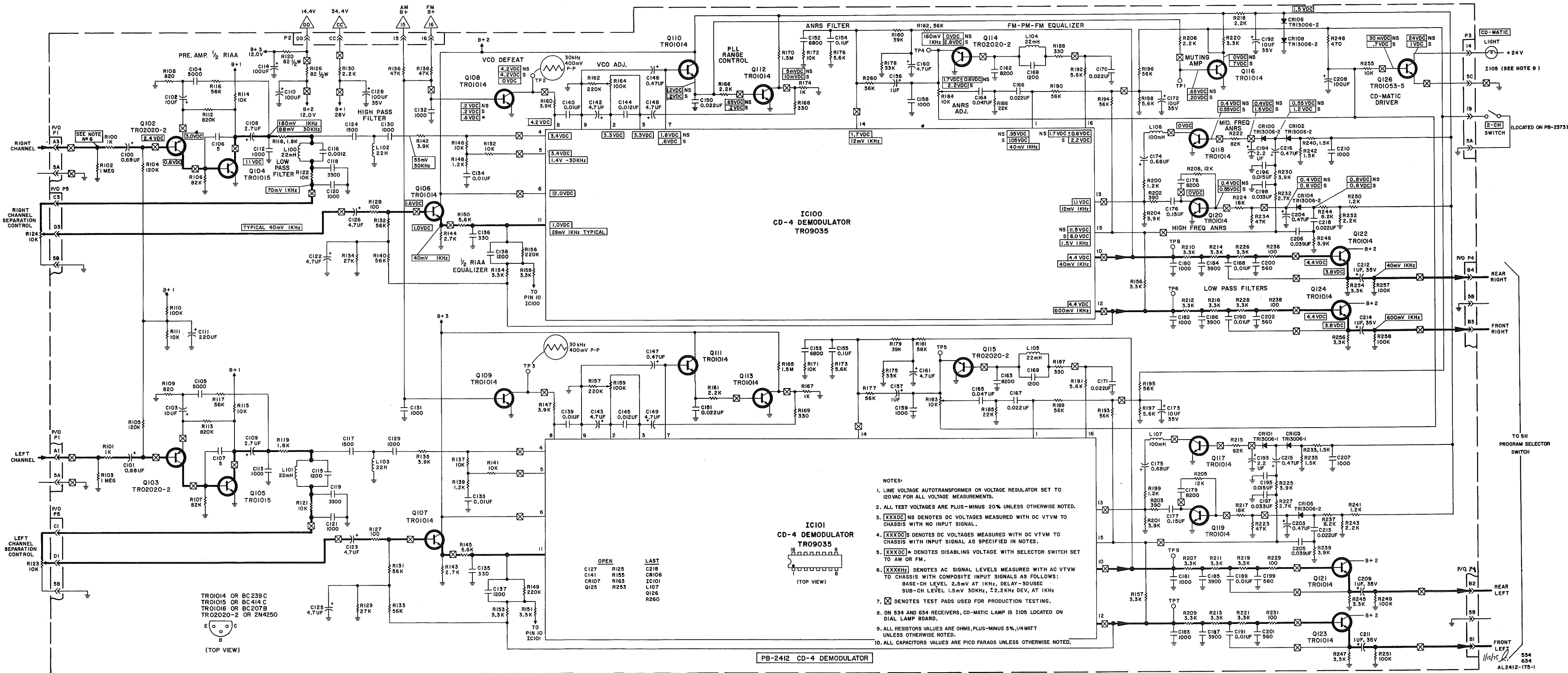

- NOTES:**
1. LINE VOLTAGE AUTOTRANSFORMER OR VOLTAGE REGULATOR SET TO 120VAC FOR ALL VOLTAGE MEASUREMENTS.
 2. ALL TEST VOLTAGES ARE PLUS-MINUS 20% UNLESS OTHERWISE NOTED.
 3. [XXXX] NS DENOTES DC VOLTAGES MEASURED WITH DC VTVM TO CHASSIS WITH NO INPUT SIGNAL.
 4. [XXXX] S DENOTES DC VOLTAGES MEASURED WITH DC VTVM TO CHASSIS WITH INPUT SIGNAL AS SPECIFIED IN NOTES.
 5. [XXXX] * DENOTES DISABLING VOLTAGE WITH SELECTOR SWITCH SET TO AM OR FM.
 6. [XXXX] KHz DENOTES AC SIGNAL LEVELS MEASURED WITH AC VTVM TO CHASSIS WITH COMPOSITE INPUT SIGNALS AS FOLLOWS:
 BASE-CH LEVEL 2.5mV AT 1KHz, DELAY-30USEC
 SUB-CH LEVEL 1.5mV 30KHz, ±2.2KHz DEV, AT 1KHz
 7. [X] DENOTES TEST PADS USED FOR PRODUCTION TESTING.
 8. ON S34 AND 634 RECEIVERS, CD-MATIC LAMP IS I106 LOCATED ON DIAL LAMP BOARD.
 9. ALL RESISTORS VALUES ARE OHMS, PLUS-MINUS 5%, 1/4WATT UNLESS OTHERWISE NOTED.
 10. ALL CAPACITORS VALUES ARE PICO FARADS UNLESS OTHERWISE NOTED.

OPEN	LAST
C127	R125
C141	R155
CR107	R163
Q125	R253
	C218
	CR108
	IC101
	L107
	Q126
	R260

PREAMPLIFIER SCHEMATIC

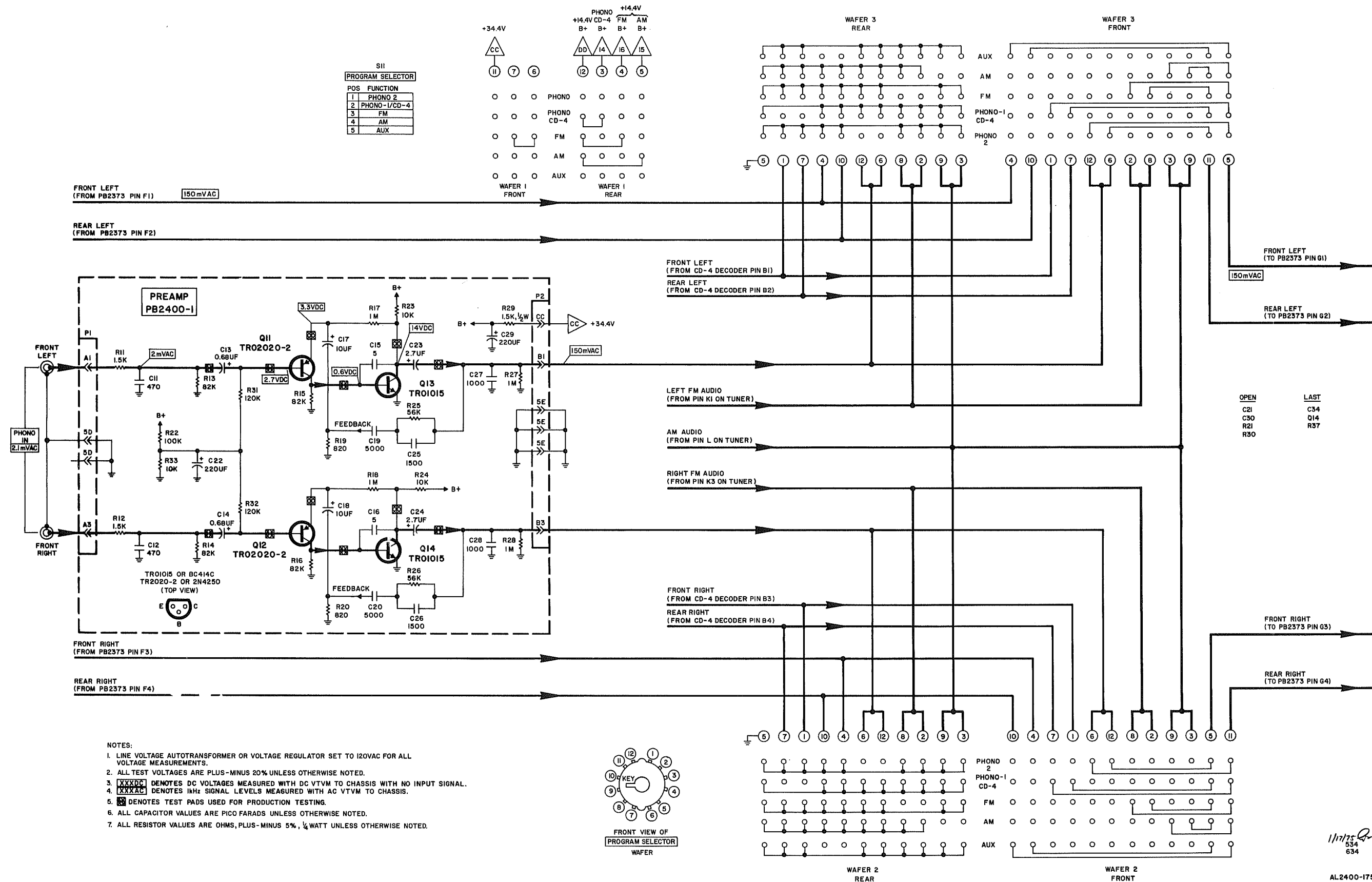

PREAMPLIFIER PARTS LIST

Ref. Des.	Description	Part Number
C11, 12	Ceramic, 470pF, 10%, 50V	CK-22350-8
C13, 14	Tantalum 0.68, 35V	CL22305-2
C15, 16	Ceramic, 5pF, 5%, 50V, NPO	CK22344-1
C17, 18	Tantalum, 10uF, 10V	CL22305-12
C19, 20	Mylar, 5000pF, 5%, 50V	CY22356-28
C22	Electrolytic, 220uF, 16V	CE22342-15
C23, 24	Tantalum, 2.7uF, 35V	CL22305-4
C25, 26	Ceramic, 1500pF, 10%, 50V	CK22351-8
C27, 28	Ceramic, 1000pF, 10%, 50V	CK22350-12
Q11, 12	Transistor, 2N4250	TR02020-2
Q13, 14	Transistor, BC414C	TR01015
R11, 12	1.5K	RF25DC152J
R13, 14	82K	RF25DC823J
15, 16		
R17, 18	1M	RF25DC105J
27, 28		
R19, 20	820	RF25DC821J
R22	100K	RF25DC104J
R23, 24	10K	RF25DC103J
33		
R25, 26	56K	RF25DC563J
R29	1.5K, 5%, 1/2W	RF50DC152J
R31, 32	120K	RF25DC124J

All resistors are deposited film, 5%, 1/4W unless otherwise noted. K = Kilohm, M = Megohm.

11/75
534
634
AL2400-175-1

SQ DECODER/GAIN CONTROL & REMOTE CONTROL UNIT SCHEMATIC

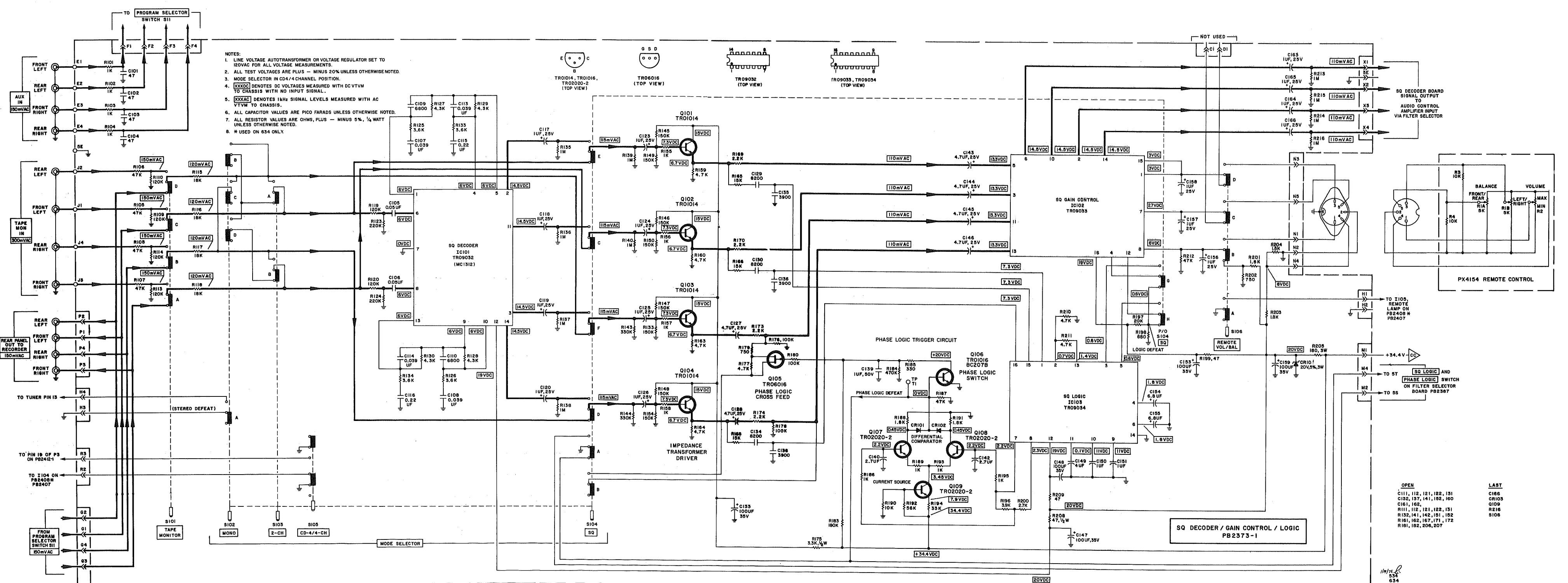

- NOTES:
1. LINE VOLTAGE AUTOTransFORMER OR VOLTAGE REGULATOR SET TO 120VAC FOR ALL VOLTAGE MEASUREMENTS.
 2. ALL TEST VOLTAGES ARE PLUS - MINUS 20% UNLESS OTHERWISE NOTED.
 3. MODE SELECTOR IN CD4/4 CHANNEL POSITION.
 4. [XXXX] DENOTES DC VOLTAGES MEASURED WITH DC VTVM TO CHASSIS WITH NO INPUT SIGNAL.
 5. [XXXX] DENOTES 1kHz SIGNAL LEVELS MEASURED WITH AC VTVM TO CHASSIS.
 6. ALL CAPACITOR VALUES ARE PICO FARADS UNLESS OTHERWISE NOTED.
 7. ALL RESISTOR VALUES ARE OHMS, PLUS - MINUS 5%, 1/4 WATT UNLESS OTHERWISE NOTED.
 8. M USED ON 634 ONLY.

- OPEN
- C111, 112, 121, 122, 131
 - C132, 137, 141, 152, 160
 - C161, 162,
 - R111, 112, 121, 122, 131
 - R132, 141, 142, 151, 152
 - R161, 162, 167, 171, 172
 - R181, 182, 206, 207
- LAST
- C188
 - C193
 - Q109
 - R216
 - S108

AL 2373-175-1

SQ DECODER/GAIN CONTROL & REMOTE CONTROL UNIT PARTS LISTS

AUDIO CONTROL AMPLIFIER SCHEMATIC

AUDIO CONTROL AMPLIFIER PARTS LIST

Ref. Des.	Description	Part Number	Ref. Des.	Description	Part Number
C101, 102, 103, 104	Ceramic, 47pF, 10%	CK22345-9	R127, 128, 129, 130	4.3K	RF25DC432J
C105, 106	Mylar, .05, 5%, 50V	CY22356-24	R135, 136, 137, 138, 139, 140, 213, 214, 215, 216	1M	RF25DC105J
C107, 108, 113, 114	Mylar, 0.039 uF, 5%, 50V	CY22356-16	R143, 144	330K	RF25DC334J
C109, 110	Mylar, 6800pF, 5%, 50V	CY22356-2	R145, 146, 147, 148, 149, 150, 153, 154	150K	RF25DC154J
C115, 116	Mylar, 0.22uF, 5%, 50V	CY22356-17	R159, 160, 163, 164, 177, 210, 211	4.7K	RF25DC472J
C117, 118, 119, 120, 123, 124, 125, 126, 150, 151, 156, 157, 158, 163, 164, 165, 166	Sintered Aluminum, 20%, 1uF, 25V	CS22340-5	R165, 166, 168	15K	RF25DC153J
C127, 128, 143, 144, 145, 146	Sintered Aluminum, 20%, 4.7uF, 25V	CS22340-6	R169, 170, 173, 174	2.2K	RF25DC222J
C129, 130, 134	Mylar, 8200 pF, 5%, 50V	CY22356-26	R175	3.3K, 5%, 1/2W	RF50DC332J
C133, 147, 148, 153, 159	Electrolytic, 100uF, 35V	CE22342-10	R176, 178, 180	100K	RF25DC104J
C135, 136, 138	Mylar, 3900 pF, 5%, 50V	CY22356-23	R179, 202	750	RF25DC751J
C139	Mylar, 1uF, 5%, 50V	CY22356-26	R183	180K	RF25DC184J
C140, 142	Tantalum, 2.7uF, 20%, 35V	CL22305-4	R184	470K	RF25DC474J
C149	Tantalum, 4uF, 35V	CL22305-14	R185	330	RF25DC331J
C154, 155	Tantalum, 6.8uF, 35V	CL22305-20	R188, 191, 201, 203	1.8K	RF25DC182J
CR101, 102	Silicon Diode	TR13006-2	R190	10K	RF25DC103J
CR103	Zener Regulator, 20V, 5%, 3W (Solitron only)	TR14001-4	R192	56K	RF25DC563J
IC101	Integrated circuit, Decoder, (MC1312)	TR09032	R194	33K	RF25DC333J
IC102	Integrated circuit, Gain Control, (MC1314)	TR09033	R196	3.9K	RF25DC392J
IC103	Integrated circuit, Logic (MC1315)	TR09034	R197	20K	RF25DC203J
Q101, 102, 103, 104,	Transistor, NPN, (BC239C)	TR01014	R198	680	RF25DC681J
Q105	Transistor, P Channel, FET	TR06016	R199, 208, 209	47	RF25DC470J
Q106	Transistor, NPN (BC207B)	TR01016	R204	1.5K	RF25DC152J
Q107, 108, 109	Transistor, PNP, (2N4250)	TR0202-2	R205	W.W, 180, 5%, 3W	RP3W181J
R101, 102, 103, 104, 155, 156, 157, 158, 186, 189, 193, 195	1K	RF25DC102J	S101-106	Switch, pushbutton, 6 position (TAPE MONITOR, MONO, 2-CH, SQ, CD-4/4-CH, REMOTE VOL/BAL)	SP50200-82
R105, 106, 107, 108, 187, 212	47K	RF25DC473J			
R109, 110, 113, 114, 119, 120	120K	RF25DC124J			
R115, 116, 117, 118	18K	RF25DC183J			
R123, 124	220K	RF25DC224J			
R125, 126, 133, 134	3.6K	RF25DC362J			
R1 A, B, C, D	5K, 4 element	RP50160-316			
R2	Slide control, 5K, 1 element	RP50160-322			
R3, 4	Deposited film, 10K, 1/4W, 5%	RF25DC103J			
	Knob, slide control	EK20043-1			
	Knob, lever	EK20050-1			
	Connector assembly	AS20519			
	5 Pole connector	PL20622			
	5 Conductor cable	WS25015			
	Case, bottom	EA415-105			
	Case, top	EA4154-105			

All resistors are deposited film, 5%, 1/4W unless otherwise noted. K = Kiloohm; M = Megohm.

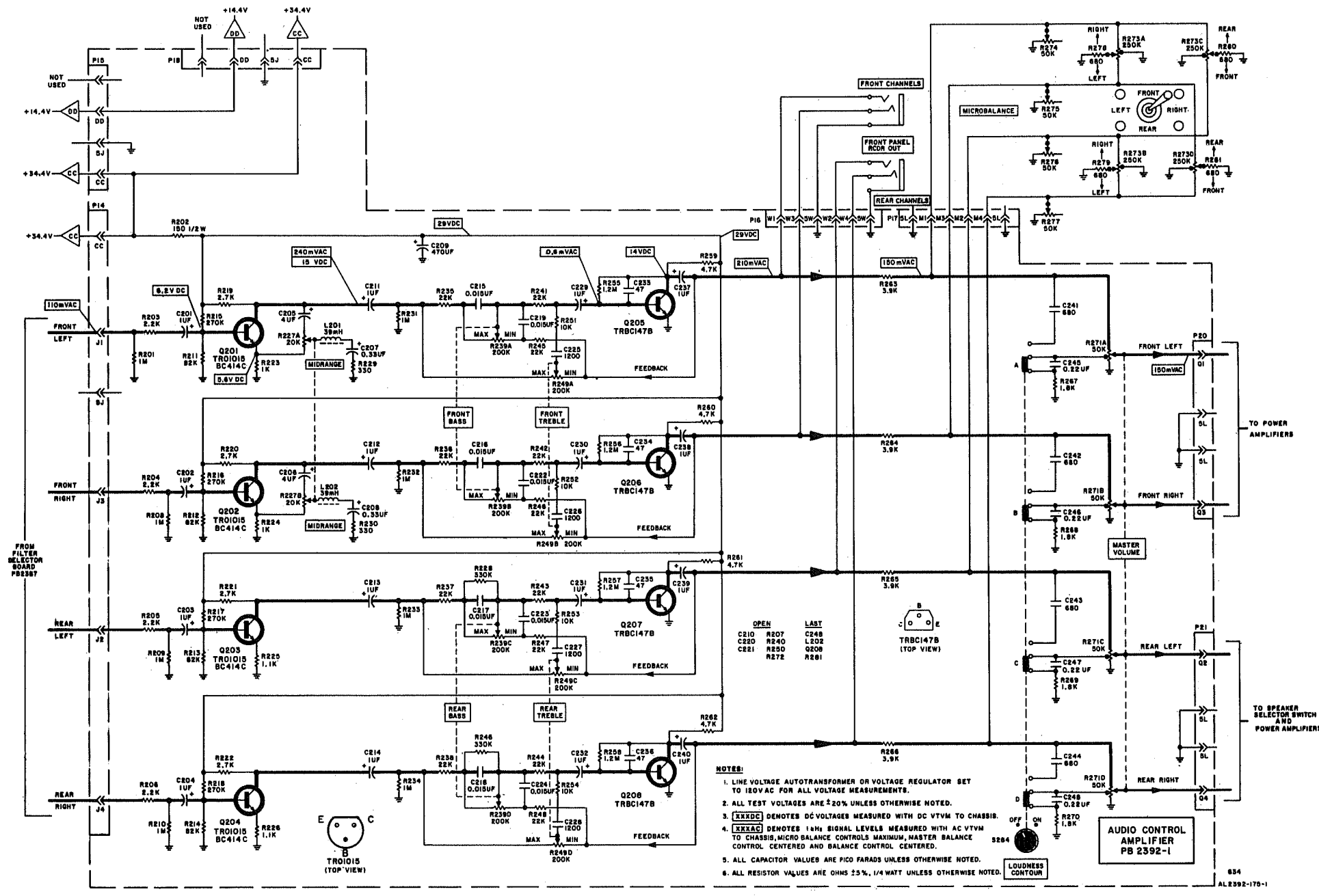

NOTES:
 1. LINE VOLTAGE AUTOTRANSFORMER OR VOLTAGE REGULATOR SET TO 150V AC FOR ALL VOLTAGE MEASUREMENTS.
 2. ALL TEST VOLTAGES ARE ±20% UNLESS OTHERWISE NOTED.
 3. [XXXX] DENOTES DC VOLTAGE MEASURED WITH DC VTVM TO CHASSIS.
 4. [XXXX] DENOTES 1 kHz SIGNAL LEVELS MEASURED WITH AC VTVM TO CHASSIS. MICRO BALANCE CONTROLS MAXIMUM, MASTER BALANCE CONTROL, CENTERED AND BALANCE CENTERED.
 5. ALL CAPACITOR VALUES ARE PICO FARADS UNLESS OTHERWISE NOTED.
 6. ALL RESISTOR VALUES ARE OHMS 25%, 1/4 WATT UNLESS OTHERWISE NOTED.

Ref. Des.	Description	Part Number
C201, 202, 203, 204, 211, 212, 213, 214,	Tantalum, 1uF, 35V	CL22305-3
C205, 206	Tantalum, 4uF, 35V	CL22305-14
C207, 208	Sintered Aluminum, 0.33uF, 25V	CS22340-3
C209	Electrolytic, 470uF, 35V	CE22343-34
C215, 216, 217, 218, 219, 222, 223, 224	Mylar, 0.15uF, 5%, 50V	CY22356-5
C225, 226, 227, 228	Ceramic, 1200 pF, 10%, 50V	CK22358-17
C229, 230, 231, 232, 237, 238, 239, 240	Sintered Aluminum, 1uF, 25V	CS22340-5
C233, 234, 235, 236	Ceramic, 47pF N330, 10%, 50V	CK22345-9
C241, 242, 243, 244	Ceramic, 680 pF, 10%, 50V	CK22347-10
C245, 246, 247, 248	Mylar, 0.22uF, 5%, 50V	CY22356-17
L201, 202	Choke, 39 mH	L50334-11
Q201, 202, 203, 204	Transistor, BC414C	TR01015
Q205, 206, 207, 208	Transistor, BC147B	TRBC147B
R201, 208, 209, 210, 231, 232, 233, 234	IM	RF25DC105J
R202	150, 1/2W	RF50DC151J
R203, 204, 205, 206	2.2K	RF25DC222J
R211, 212, 213, 214	82K	RF25DC823J
R215, 216, 217, 218	270K	RF25DC274J
R219, 220, 221, 222	2.7K	RF25DC272J
R223, 224	1K	RF25DC102J
R225, 226	1.1K, 1/4W, 5%	RF25DC112J
R227A, B	MIDRANGE Control, 20K	RF50160-323
R228, 246	330K	RF25DC334J
R229, 230	330	RF25DC331J
R235, 236, 237, 238, 241, 242, 243, 244, 245, 246, 247, 248	22K	RF25DC223J

**AUDIO CONTROL AMPLIFIER
PARTS LIST (CONT'D.)**

Ref. Des.	Description	Part Number
R239 A, B, C, D 249 A, B, C, D	Tone Controls, 200K 4 element (BASS, TREBLE)	RF50160-313
R251, 252, 253, 254	10K	RF25DC103J
R255, 256, 257, 258	1.2M	RF25DC125J
R259, 260, 261, 262	4.7K	RF25DC472J
R263, 264, 265, 266	3.9K	RF25DC392J
R267, 268, 269, 270	1.8K	RF25DC182J
R271, A, B, C, D S284	Volume Control, 50K, 4 element (MASTER VOLUME) LOUDNESS CONTOUR Switch, Rotary, 2 position (ON-OFF)	RF50160-311 SR2391-120

All resistors are deposited film, 5%, 1/4W unless otherwise noted.
K = Kilohm, M = Megohm.

FILTER SELECTOR BOARD PARTS LIST

Ref. Des.	Description	Part Number
C130, 131, 132, 133	Mylar, 0.039uF, ±5%, 50V	CY22356-16
C134, 135, 136, 137	Mylar, 0.027uF, ±5%, 50V	CY22356-22
S277	Switch, pushbutton, 6 position (METER ATTEN, MUTING OFF, PHASE LOGIC, SQ LOGIC, HIGH FILTER, LOW FILTER)	SP-50200-80

FILTER SELECTOR BOARD SCHEMATIC

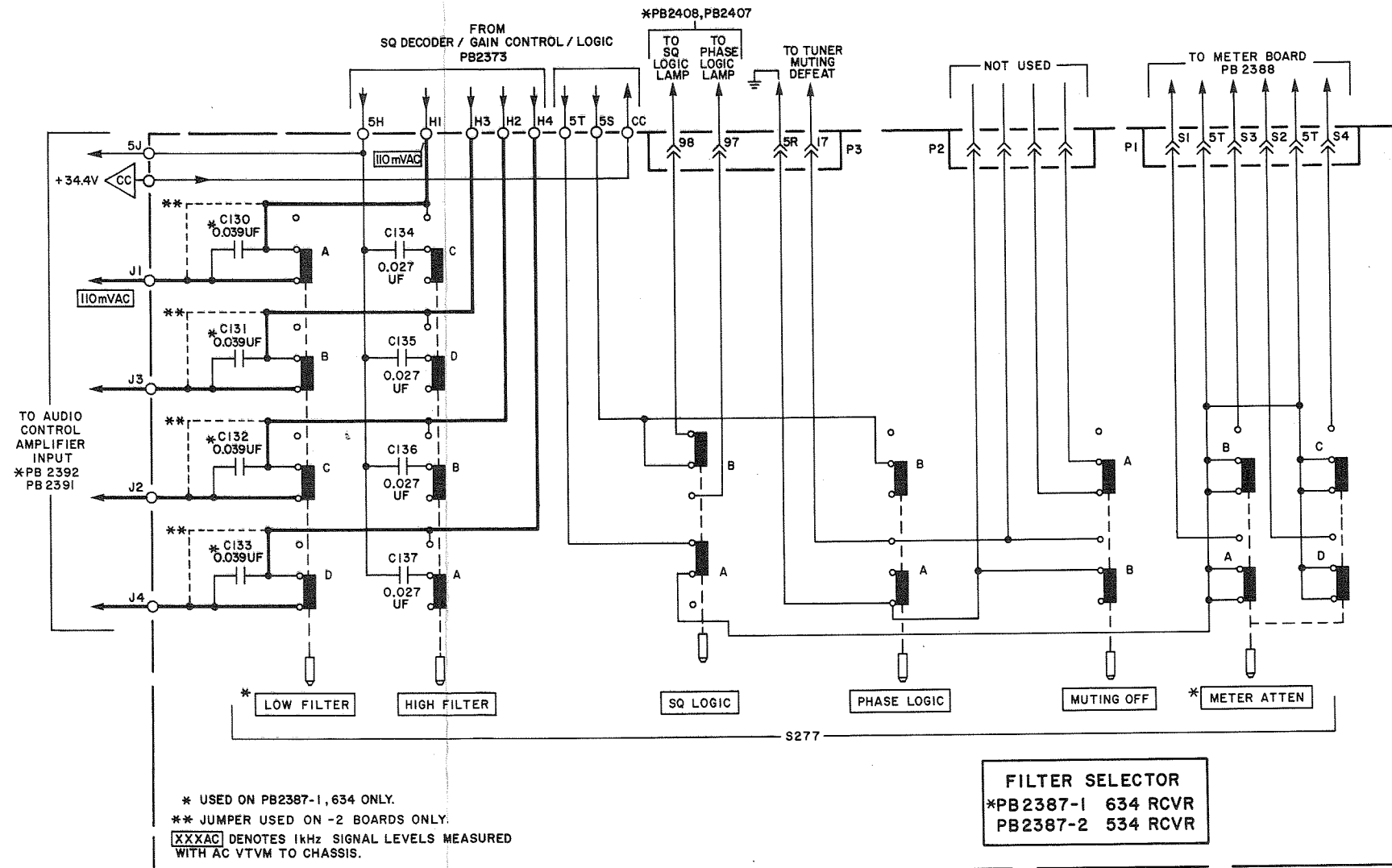

AL2387-175-1
11/15/75

VU METER BOARD SCHEMATIC

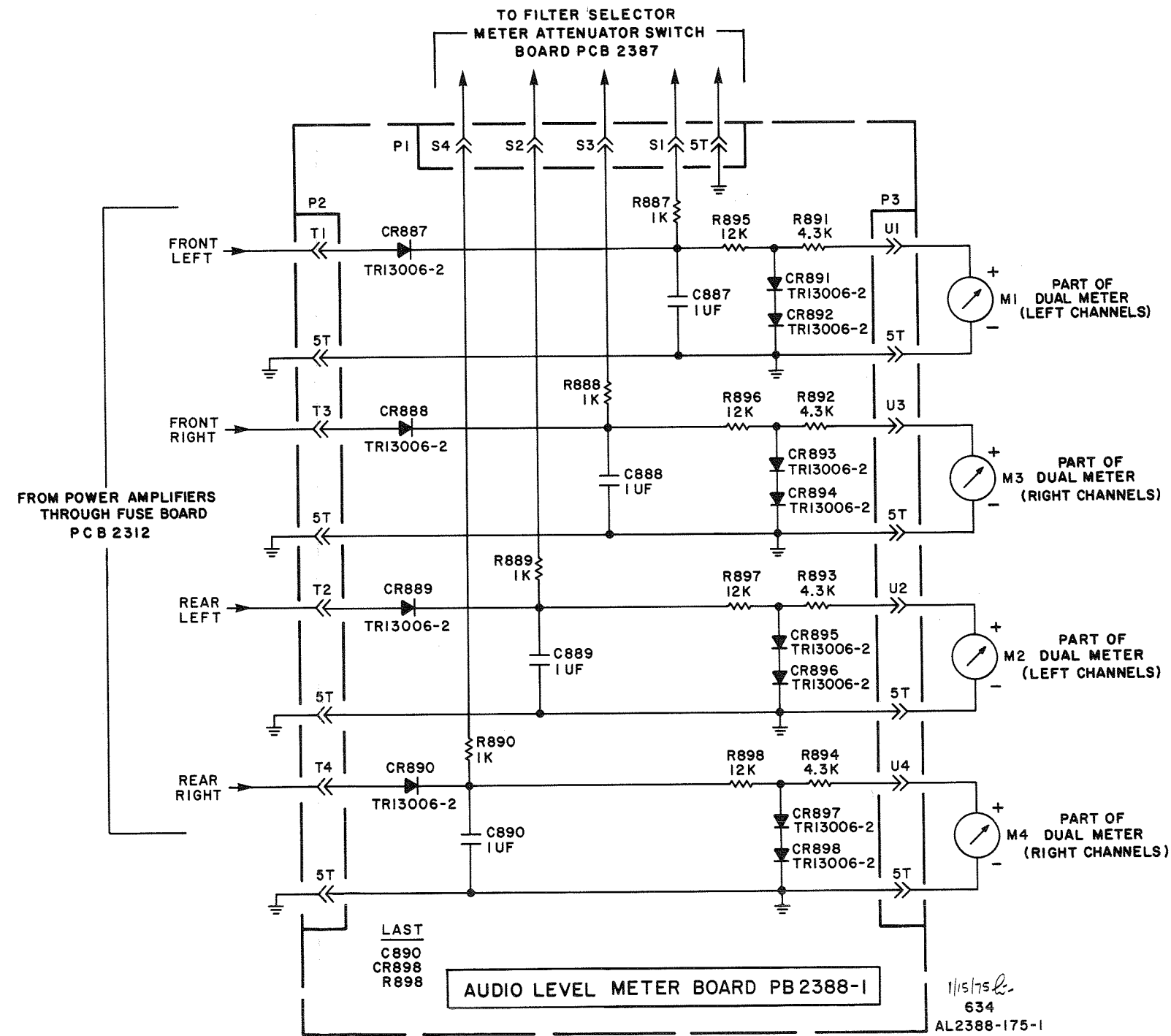

AUDIO LEVEL METER BOARD PARTS LIST

Ref. Des.	Description	Part Number
C887, 888, 889, 890	Mylar, 1uF, 5%, 50V	CY22356-27
CR887 through 898	Silicon Diodes	TR13006-2
R887, 888, 889, 890	1K	RF25DC102J
R891, 892, 893, 894	4.3K	RF25DC432J
R895, 896, 897, 898	12K	RF25DC123J

All resistors are deposited film, 5%, 1/4W unless otherwise noted. K = Kilohm.

PRE-DRIVER/DRIVER AND POWER MODULE SCHEMATIC

Note: The 634 receiver contains two (2) Pre-Driver/Driver Circuit Boards; one board for two channels. For the sake of simplicity, and to avoid duplication, only one parts list and one Schematic is presented.

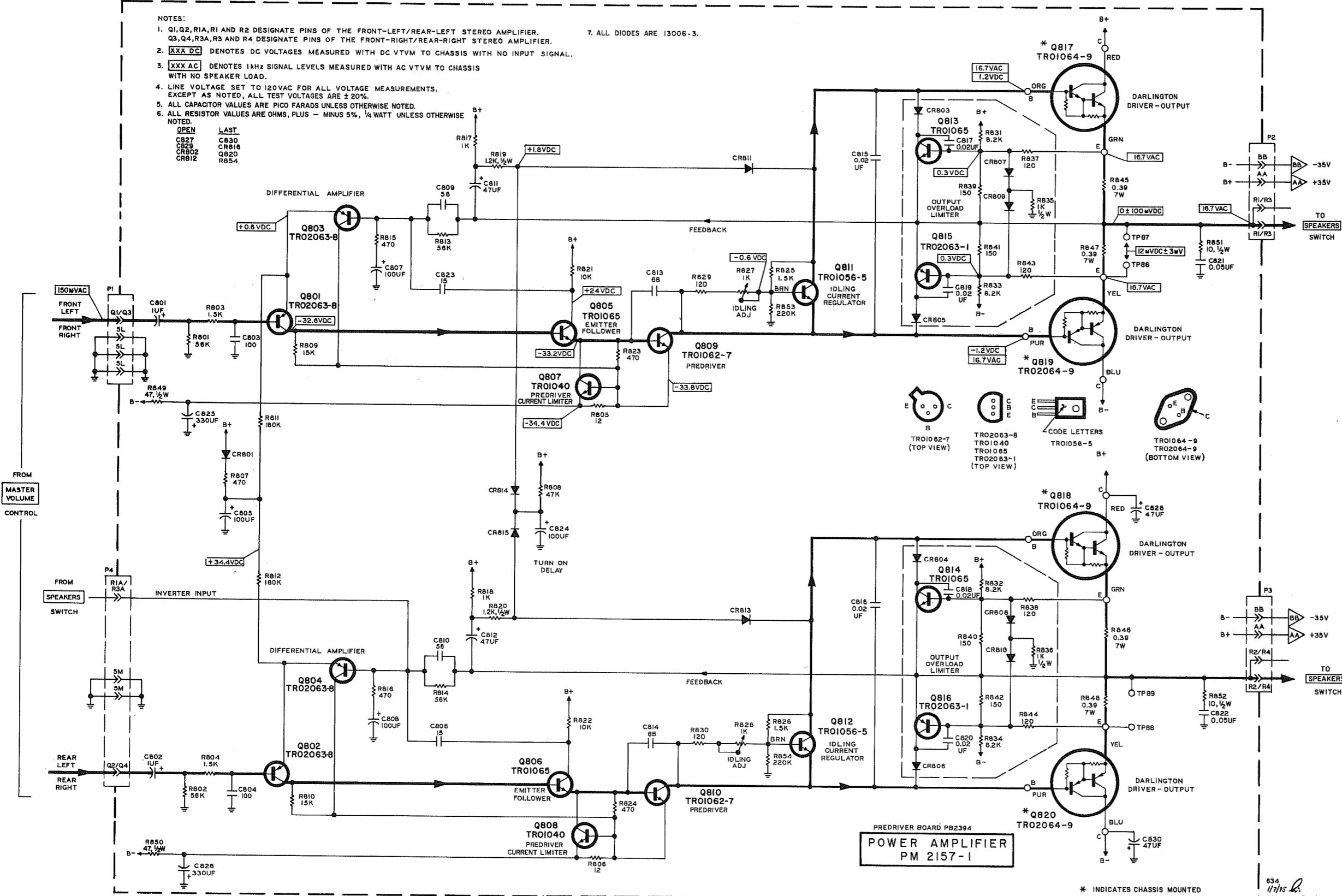

- NOTES:
- Q1, Q2, R1A, R1 and R2 DESIGNATE PINS OF THE FRONT-LEFT/REAR-LEFT STEREO AMPLIFIER. Q3, Q4, R3A, R3 and R4 DESIGNATE PINS OF THE FRONT-RIGHT/REAR-RIGHT STEREO AMPLIFIER.
 - XXX DC DENOTES DC VOLTAGES MEASURED WITH DC VTVM TO CHASSIS WITH NO INPUT SIGNAL.
 - XXX AC DENOTES 1KHz SIGNAL LEVELS MEASURED WITH AC VTVM TO CHASSIS WITH NO SPEAKER LOAD.
 - LINE VOLTAGE SET TO 120VAC FOR ALL VOLTAGE MEASUREMENTS. EXCEPT AS NOTED, ALL TEST VOLTAGES ARE ± 20%.
 - ALL CAPACITOR VALUES ARE PICO FARADS UNLESS OTHERWISE NOTED.
 - ALL RESISTOR VALUES ARE OHMS, PLUS - MINUS 5%, 1/4 WATT UNLESS OTHERWISE NOTED.
 - ALL DIODES ARE 13006-3.

PRE-DRIVER/DRIVER AND POWER MODULE PARTS LISTS

Ref. Des.	Description	Part Number
C801, 802	Tantalum, 1uF, 35V	CL22305-3
C803, 804	Ceramic, 100pF, 10%, 50V	CK22351-1
C805, 824	Electrolytic, 100uF, 50V	CE22342-9
C806, 823	Ceramic, 15pF, NPO, 5%, 50V	CK22344-9
C807, 808	Electrolytic, 100uF, 16V	CE22342-12
C809, 810	Ceramic, 56pF, N150, 10%, 50V	CK22360-16
C811, 812	Electrolytic, 47uF, 35V	CE22342-7
C813, 814	Ceramic, 68pF, N750, 5%, 50V	CK22344-26
C815, 816, 817, 818, 819, 820	Ceramic, 0.02uF, 50V	CK22354-2
C821, 822	Ceramic, 0.05uF, + 80 -20%, 100V	CK22362-14
C825, 826	Electrolytic, 330uF, 50V	CE22342-27
CR801, 803, 804, 805, 806, 807, 808, 809, 810, 813, 814, 815, 816, 817, 818, 819, 820, 821, 822, 823, 824, 825, 826, 827, 828, 829, 830, 831, 832, 833, 834, 835, 836, 837, 838, 839, 840, 841, 842, 843, 844, 845, 846, 847, 848, 849, 850, 851, 852, 853, 854	Silicon Diode	TR13006-3
R801, 802, 813, 814	56K	RF25DC563J
R803, 804, 825, 826	1.5K	RF25DC151J
R805, 806, 807, 815, 816, 823, 824	12, 470	RF25DC120J RF25DC471J
R808, 811, 812	47K, 180K	RF25DC473J RF25DC184J
R817, 818, 835, 836	1K, 1/2W, 5%	RF50DC102J
R819, 820	1.2K, 1/2W, 5%	RF20BF122J
R821, 822	10K	RF25DC103J
R827, 828	Variable, 1K, ± 30%	R50150-20-2
R831, 832, 833, 834	8.2K	RF25DC822J
R837, 838, 843, 844	120	RF25DC121J
R839, 840, 841, 842	150	RF25DC151J
R845, 846, 847, 848	Wirewound, 0.39, 5%, 7W	RF7WR39J
R849, 850	47, 1/2W, 5%	RF50DC470J
R851, 852	Composition, 10, 1/2W, 10%	RC20BF100K
R853, 854	220K	RF25DC224J
Q801, 802, 803, 804	Transistor, PNP	TRO2063-8
Q805, 806, 813, 814	Transistor, NPN	TRO1065
Q807, 808	Transistor, NPN	TRO1040
Q809, 810	Transistor, NPN	TRO1062-7
Q811, 812	Transistor	TRO1056-5
Q817, 818	Transistor, Darlington Driver, Output	TRO1064-9
Q819, 820	Transistor, Darlington Driver, Output	TRO2064-9
—	Temperature Circuit Breakers, 105°C	SM51486

All resistors are deposited film, 5%, 1/4Watt unless otherwise noted. K = Kiloohm.

SPEAKERS SELECTOR SWITCH SCHEMATIC

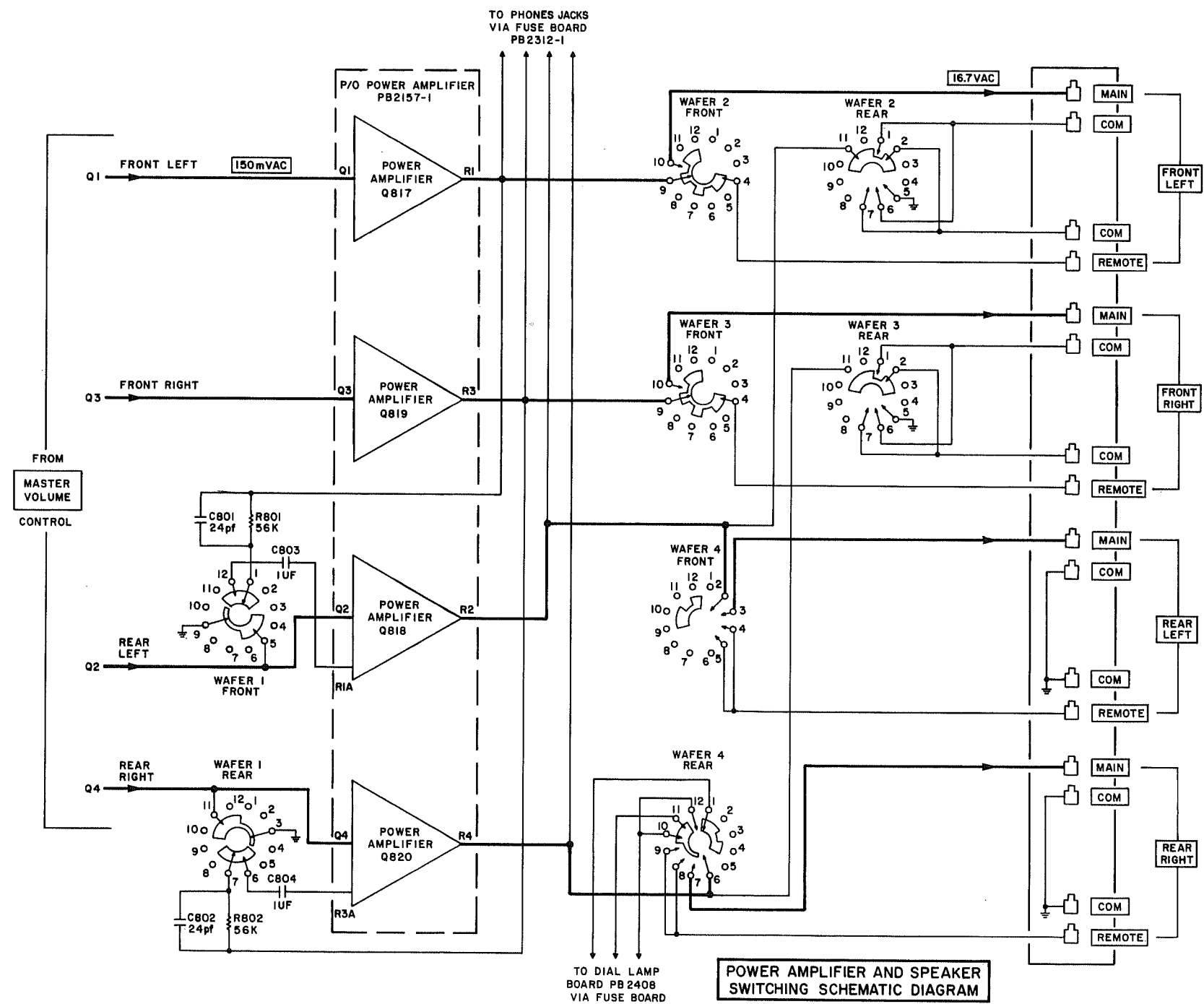

S801 SPEAKERS SELECTOR SWITCH

POS	FUNCTION	CHANNEL
1	REMOTE	2 CHANNEL
2	MAIN	
3	PHONES ONLY	4 CHANNEL
4	MAIN	
5	REMOTE	
6	MAIN + REMOTE	

SPEAKERS SELECTOR SWITCH PARTS LIST

Ref. Des.	Description	Part Number
S801	Selector switch, SPEAKERS	SR4121 150
C801,802	Ceramic, 24pf. 50V, N150	CK22356-19
C803,804	Mylar, 1.0uf, 5% 50V	CY22356-27
R801,802	Deposited carbon, 56K, 5%, 1/4W	RF25DC563J

- NOTES:
1. LINE VOLTAGE AUTOTRANSFORMER OR VOLTAGE REGULATOR SET TO 120VAC FOR ALL VOLTAGE MEASUREMENTS.
 2. ALL TEST VOLTAGES ARE PLUS - MINUS 20% UNLESS OTHERWISE NOTED.
 3. XXXXAC DENOTES 1kHz SIGNAL LEVELS MEASURED WITH AC VTVM TO CHASSIS.

11/20/75 LC
634
AL4121-175-1

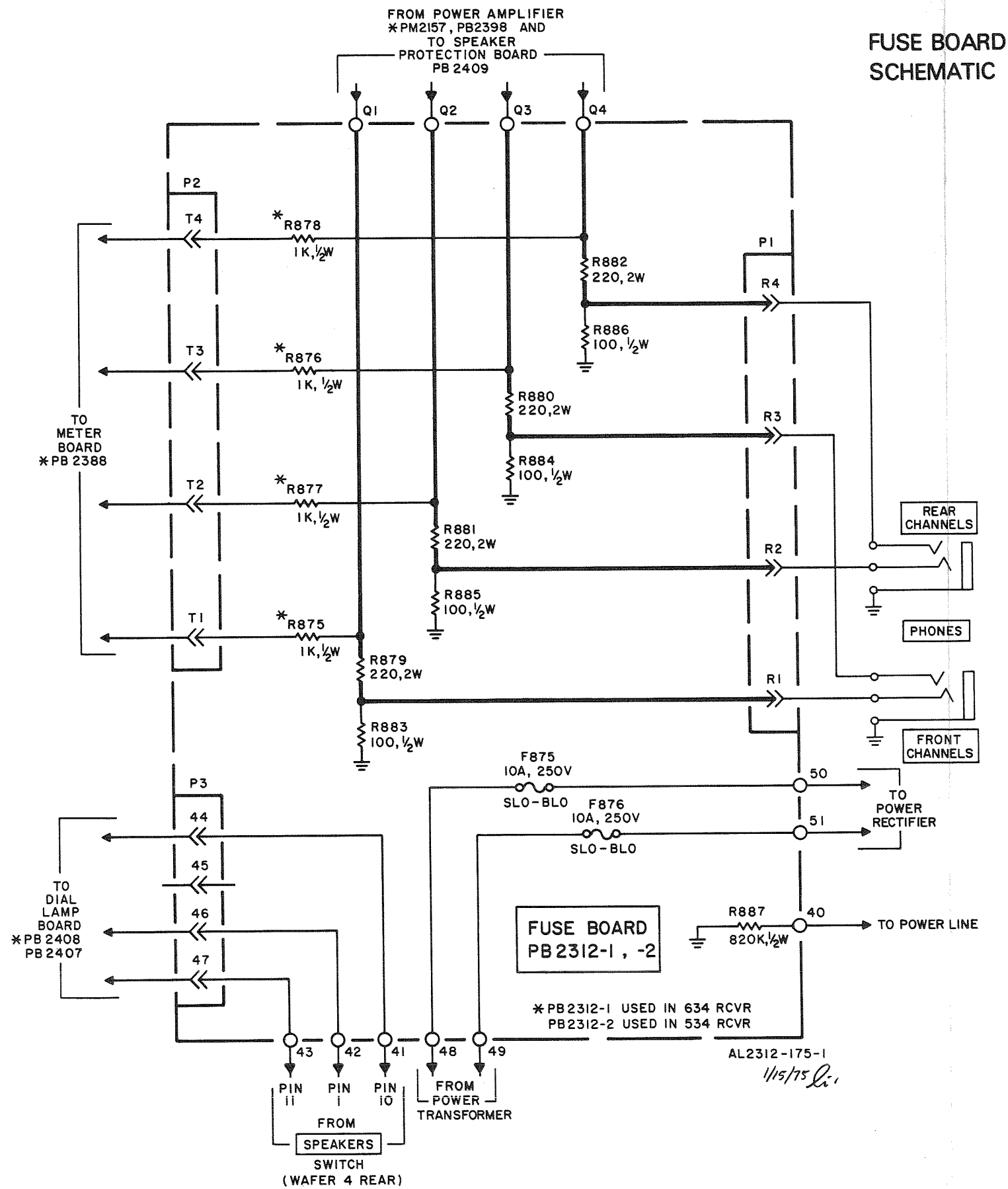

SPEAKER PROTECTION BOARD SCHEMATIC

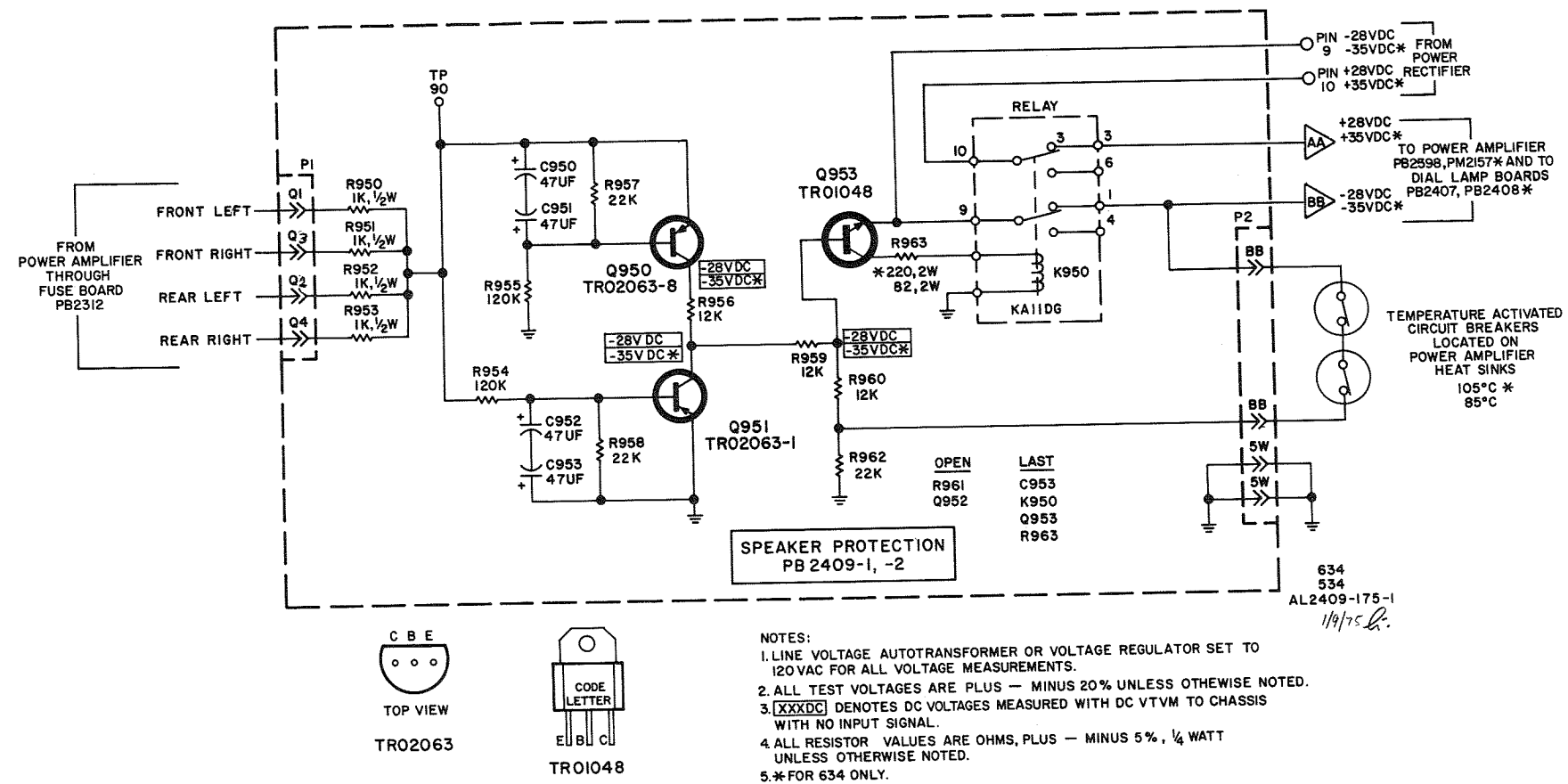

SPEAKER PROTECTION BOARD PARTS LIST

Ref. Des.	Description	Part Number
C950, 951	Electrolytic, 47uF, 16V	CE22342-8
952, 953		
K950	Relay, KA11DG, 25 VDC	SK51490
Q950	Transistor	TR02063-8
Q951	Transistor	TR02063-1
Q953	Transistor	TR01048
R950, 951, 952, 953	1K, 5%, 1/2W	RF50DC102J
R954, 955	120K	RF25DC124J
R956, 959, 960	12K	RF25DC123J
R957, 958, 962	22K	RF25DC223J
R963	W.W., 82, 5%, 2W	RP2W221J

All resistors are deposited film, 5%, 1/4W unless otherwise noted. K = Kilohm,

DIAL LAMP BOARD SCHEMATIC

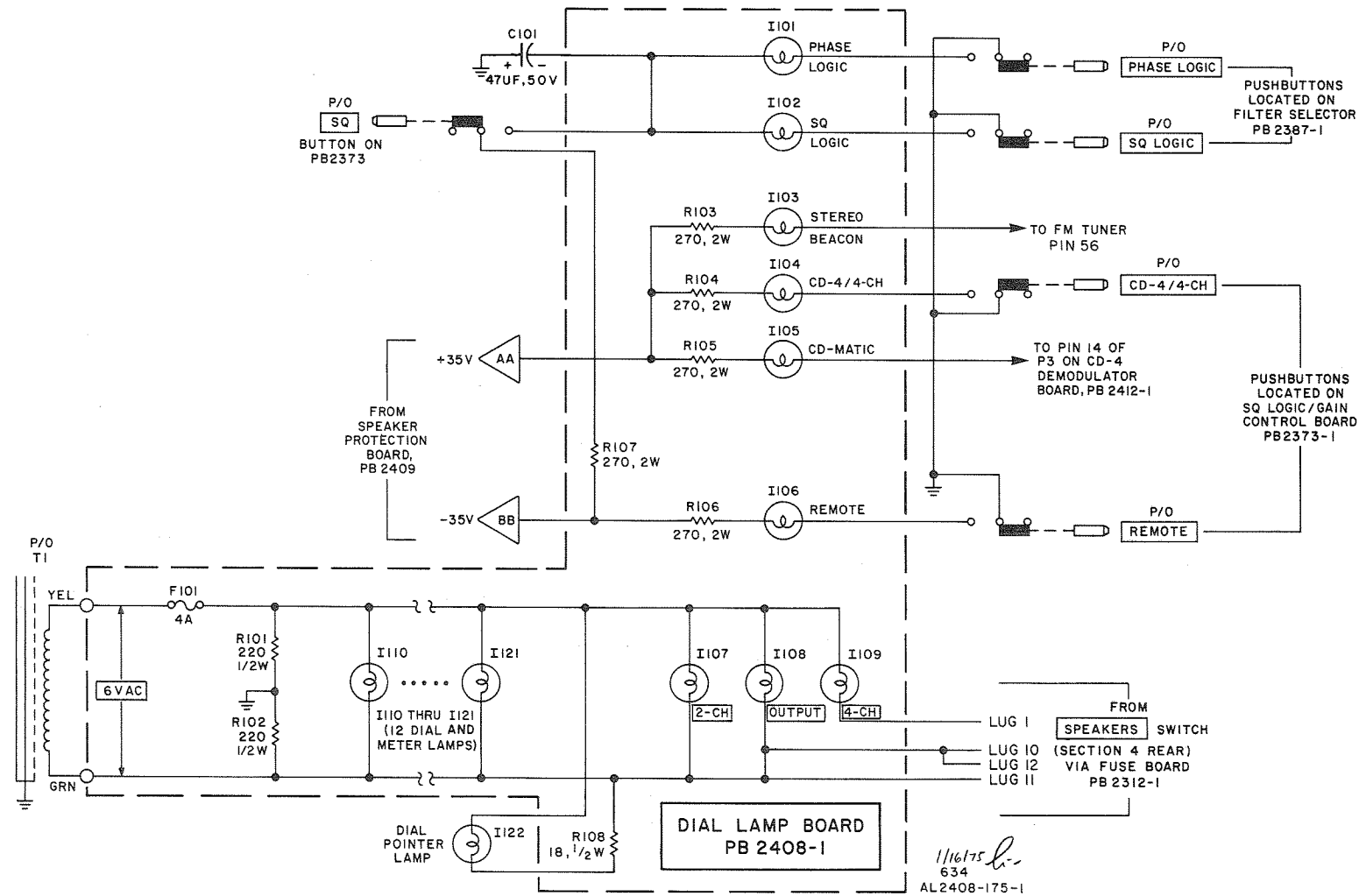

DIAL LAMP BOARD PARTS LIST

Ref. Des.	Description	Part Number
C101	Electrolytic, 47uF, 50V	CE22343-19
F101	Fuse, 4A, 125V Slo-Blo (Pigtail)	FL51313-15
I101	Lamp, 28V, (2187D) G.E.	LM21421-7
I106	through	
I107	Lamp, 6V, (2112D) G.E.	LM21421-6
I121	through	
R101, 102,	Composition, 220, 10%, 1/2W	RC20BF221K
R103, 104,	Wirewound, 270, 5%, 2W	RW200W271J
105, 106		
107		
R108	Composition, 18, 10%, 1/2W	RC20BF180K

POWER SUPPLY SCHEMATIC

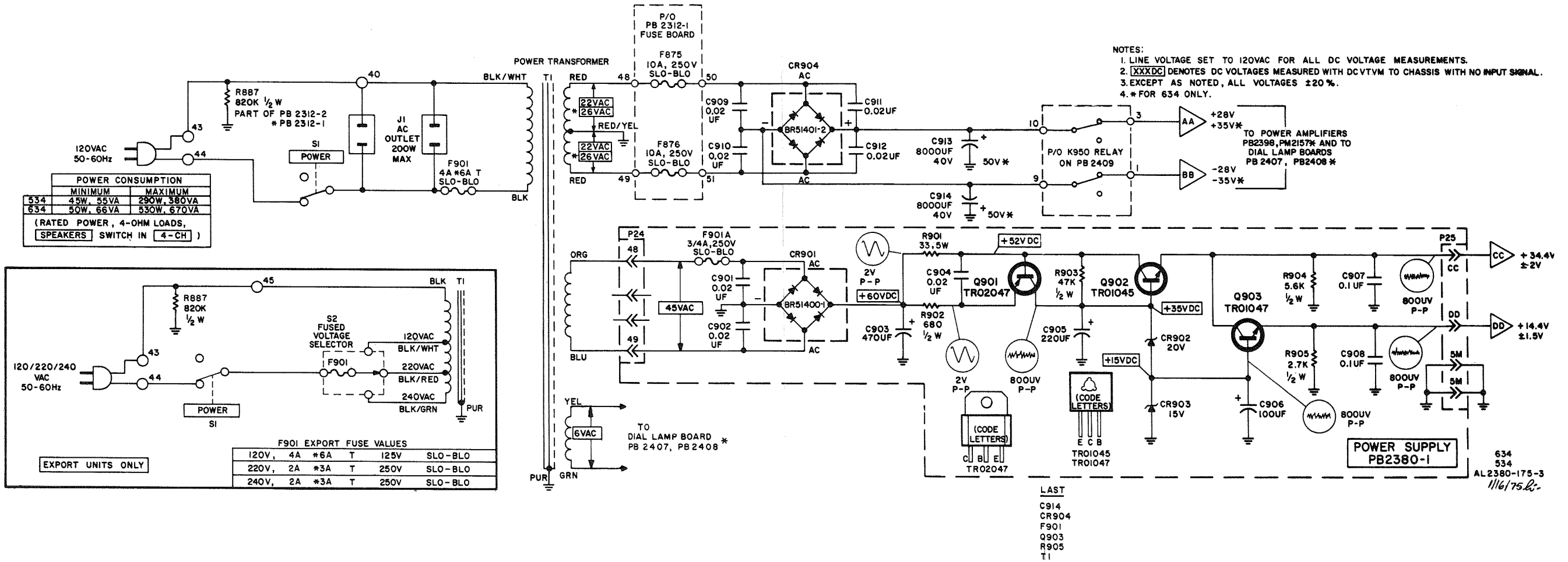

POWER SUPPLY PARTS LIST

Ref. Des.	Description	Part Number
C901, 902, 904	Ceramic, 0.02uF, 20%, 500V	CK22359-3
C903	Electrolytic, 470uF, 100V	CE22343-44
C905	Electrolytic, 220uF, 50V	CE22343-28
C906	Electrolytic, 100uF, 25V	CE22343-26
C907, 908	Mylar, 0.1uF, 10%, 100V	CY22373-1
CR901	Bridge Rectifier, 1.5A, 200V	BR51400-1
CR902	Zener, 20V, 5%, 1W	TR14002-4
CR903	Zener, 15V, 5%, 1W	TR14002-2
F901 A	Fuse, 3/4A, 250V, Slo-Blo	FL51313-7
Q901	Transistor, PNP	TR02047
Q902	Transistor, NPN	TR01045
Q903	Transistor, NPN	TR01047
R901	Wirewound, 33, 5%, 5W	RW5W330J
R902	680	RF50DC681J
R903	47K	RF50DC473J
R904	5.6K	RF50DC562J
R905	2.7K	RF50DC272J
CHASSIS MOUNTED COMPONENTS		
C909, 910, 911, 912	Ceramic, 0.02uF, 20%, 500V	CK22359-3
C913, 914	Electrolytic 8000uF, 50V	CE22374-3
CR904 A,	Bridge Rectifier, 25A, 200V	BR51401-2
F901	Fuse, 6A, 125V, Slo-Blo	FL51313-25
*F901	Fuse, 3A, 250V, Slo-Blo	FL51313-34
J1	AC Outlet	JK25009
S1	Switch, Pushbutton (POWER)	SP50200-65
S2	Multiple Voltage Selector	EA51449
T1	Transformer, Power	TD4121-115
*T1	Transformer, Power	TE4121-215
—	Fuse Holder	EA51408
—	Line Cord	W50023-1
—	*Line Cord	WR20678

All resistors are deposited film, 5%, 1/2W unless otherwise noted. K = Kiloohm.

*Export models only.

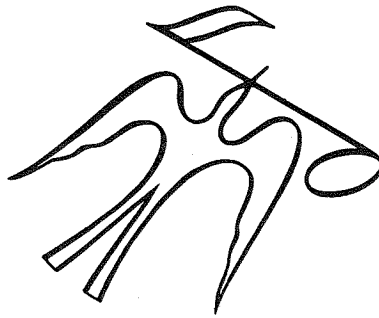

FISHER RADIO • 11-40 45th ROAD • LONG ISLAND CITY • NEW YORK 11101