

*Stereophonic*

**THE FISHER  
AMBASSADOR V  
SERVICE  
MANUAL**

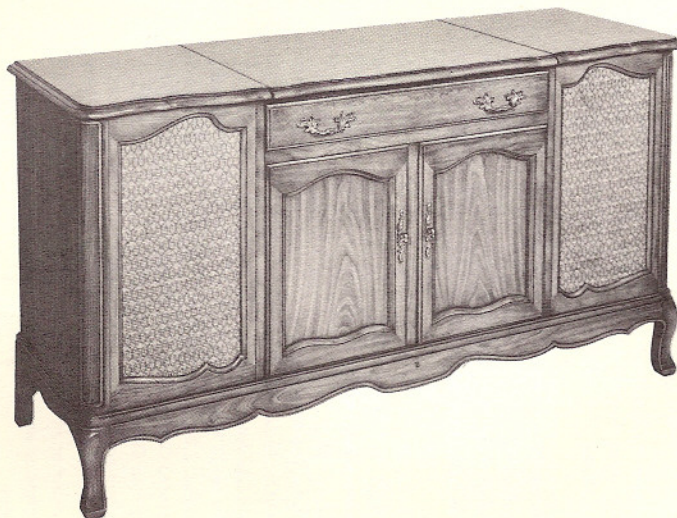

MODEL A-68

PRICE: \$1.00

FISHER RADIO CORPORATION • NEW YORK



**THE FISHER A-68**



# PARTS DESCRIPTION LIST

## TUNER — PREAMPLIFIER

Symbol	Description	Part No.
C7	Capacitor, FM-AM Variable	C953-115
C16	Capacitor, Ceramic, 5pF, $\pm$ .5pF, NPO, 500V	CC20CJ050D5
C20, 25	Capacitor, Ceramic Trimmer	C662-123
C30	Capacitor, Ceramic, 5pF, $\pm$ .5pF, N150, 500V	CC20PJ050D5
C31	Capacitor, Ceramic, 10pF, $\pm$ .5pF, NPO, 500V	CC20CJ100D5
C74	Capacitor, Electrolytic, 3 Section: A — 20uf, 300V B — 40uf, 350V C — 10uf, 250V	C50180-46
C77	Capacitor, Electrolytic, 8uf, 50V	C629-138
C79	Capacitor, Electrolytic, .5uf, 350V	C50283-7
C80	Capacitor, Electrolytic, 2uf, 70V	C721-142
CR1, 4, 5, 6, 7	Diode, Type 1112	V-1112
I1	Bulb, #47	I50009-1
I2, 3	Lamp, Dial	I50082-7
L1	AM Loop Antenna	L50210-36
L2	FM Antenna Coil	L818-113
L3	Choke, RF	L629-180
L4	Choke, 1.5 Microhenry	L50066-4
L5	Transformer, AM I.F.	L50210-35
L6	FM RF Coil	L953-119
L7	Choke, .68 Microhenry	L50066-1
L8, 9	FM Oscillator Coil Assembly	A5953-116
L10	AM Oscillator Coil	L50210-28
L11	Choke, .2 Microhenry	L50066-21
L12	Choke, 3.3 Microhenry	L50066-8
PC1, 2	Printed Circuit, Phono Equalization	PC50187-12
PC3, 4	Printed Circuit, Tone Control	PC50187-9
R54, 55	Potentiometer, Dual, 500K, Bass	R50160-119
R57, 58	Potentiometer, Dual, 500K, Treble	R50160-119
R62	Potentiometer, 500K, Balance	R50160-121
R71, 72	Potentiometer, Dual, 500K, Volume	R50160-122
RL1	Relay	K50363
S1	Switch, Selector	S961-120
S2, 3	Switch, Slide	S50200-5
—	Switch, Speaker Selector	S963-118
Z1	FM I.F. Transformer	ZZ662-117
Z2	AM I.F. Transformer	ZZ50210-1
Z3	FM I.F. Transformer	ZZ2987
Z4	AM I.F. Transformer	ZZ2984
Z5	FM Limiter Coil	ZZ50210-6
Z6	FM Ratio Detector Transformer	ZZ50210-9
—	Tube Shield, 7 Pin	E3330

—	Tube Shield, 9 Pin	E3287
—	Dial Glass	N961-109
—	Dress Panel	A5986-117
—	Escutcheon for Dress Panel	A537-118
—	Dipole Assembly	A550227-2
—	45 RPM Spindle	A50412-3
—	Knob	E50324
—	Knob, Dual Top	E50323
—	Knob, Dual Bottom	E50321
—	Knob, Speaker Selector	E50325-1
—	Cartridge	G50286-1
—	Jewel, Green	I50162-4
—	Automatic Turntable	RC832-109

## SPEAKER SYSTEM

Symbol	Description	Part No.
LS1	Woofers, 12"	W-112
LS2	Midrange, 8"	M-113
LS 3	Tweeter, 3 1/2"	T-109
L1	Coil	L-202
L2	Coil	L-205
C1	Capacitor, 6uf	C-302
C2	Capacitor, 2uf	C-301
R1	Resistor, 10 ohm	R-404
R2	Resistor, 15 ohm	R-405

## POWER AMPLIFIER

### CAPACITORS

Symbol	Description	Part No.
10% tolerance for all fixed capacitors, unless otherwise noted or marked GMV (guaranteed min. value). All capacitors not marked uf are pF (uuf).		
C1, 2	Ceramic, 1, 20%, P100, 1000V	C50070-1
C3, 4	Electrolytic, 50uf, 3V	C50283-1
C5	Mylar, .047uf, 400V	C50197-30
C6	Mylar, .047uf, 250V	C50197-52
C7	Ceramic, 100, 1000V	C50070-6
C8	Mylar, .047uf, 400V	C50197-30
C9	Mylar, .047uf, 250V	C50197-52
C10	Ceramic, 100, 1000V	C50070-6
C11, 12	Ceramic, 18, N470, 1000V	C50070-13
C13	Electrolytic, 3 Section: A — 40uf, 450V B — 40uf, 450V C — 100uf, 300V	C50180-44
C14	Electrolytic 3 Section: A — 60uf, 250V B — 60uf, 250V C — 100uf, 100V	C50180-17

C15	Electrolytic, 100uf, 300V	C50180-43
C16	Molded, .01uf, 20%, 600V	C2747
C17, 18	Ceramic, 330, 1000V	C50072-1
C19	Molded, .01uf, 20%, 600V	C2747

## RESISTORS & POTENTIOMETERS

In Ohms, 5% tolerance, 1/2 Watt, unless otherwise noted. K=Kilohms, M=Megohms.

Symbol	Description	Part No.
R1, 2	Dep. Carbon, 3.3M	R33DC335J
R3, 4	Dep. Carbon, 47K	R33DC473J
R5	Dep. Carbon, 470K	R33DC474J
R6	Dep. Carbon, 1K	R33DC102J
R7	Dep. Carbon, 220	R33DC221J
R8	Dep. Carbon, 470K	R33DC474J
R9	Dep. Carbon, 1K	R33DC102J
R10	Dep. Carbon, 220K	R33DC221J
R11, 12	Dep. Carbon, 180K	R33DC184J
R13	Potentiometer, 50K, AC Balance	R50103-3
R14	Dep. Carbon, 33K	R33DC333J
R15	Dep. Carbon, 68K	R33DC683J
R16	Potentiometer, 50K, AC Balance	R50103-3
R17	Dep. Carbon, 68K	R33DC683J
R18	Composition, 5.6K, 10%, 1/2 W	RC20BF562K
R19, 20	Dep. Carbon, 10K	R33DC103J
R21	Composition, 4.7K, 10%, 1W	RC30BF472K
R22, 23, 24, 25	Dep. Carbon, 330K	R33DC334J
R26	Potentiometer, 5K, Bias Adj.	R50103-4
R27	Glass, 3.3K, 10%, 3W	RPG3W332K
R28	Glass, 470, 10%, 3W	RPG3W471K
R29, 30, 31, 32	Dep. Carbon, 1K	R33DC102J
R33	Composition, 6.8K, 10%, 1/2 W	RC20BF682K
R34	Glass, 1.5K, 10%, 7W	RPG7W152K
R35	Glass, 470, 10%, 3W	RPG3W471K
R36	Glass, 600, 10%, 5W	RPG5W601K
R37, 38	Composition, 220, 10%, 1/2 W	RC20BF221K
R39	Composition, 820K, 10%, 1/2 W	RC20BF824K
R40	Dep. Carbon, 33K	R33DC333J

## MISCELLANEOUS

Symbol	Description	Part No.
CR1, 2	Silicon Diode	SR50411-1
F1	Fuse, 3.2 Amp., Slo-Blo	F3319
I1	Bulb, Pilot Light #47	I50009-1
S1	Switch, Speaker Selector	S936-118
T1, 2	Transformer, Output	T964-116-1
T3	Transformer, Power	T964-115

# PARTS DESCRIPTION LIST • MULTIPLEX SECTION

## CAPACITORS

10% tolerance for all fixed capacitors, unless otherwise noted or marked GMV (guaranteed minimum value). All capacitors not marked uf are pF (uuf).

Symbol	Description	Part No.
C200	Ceramic, .01uf, +80 — 20%, 500V	C50089-7
C201	Ceramic, 680, 1000V	C50072-2
C203	Ceramic, 220, 1000V	C50183-3
C204	Polystyrene, 470, 5%, 500V	C50394-1
C205	Ceramic, 82, 1000V	C50070-1
C206	Ceramic, 1000, GMV, 500V	C50089-2
C207	Ceramic, 5000, +80 — 20%, 500V	C50089-6
C208, 209	Mica, 4700, 5%, 500V	C50332-5
C210	Electrolytic, 1uf, 350V	C50283-3
C211	Ceramic, 1000, GMV, 500V	C50089-2
C212	Ceramic, .05uf, +80 — 20%, 100V	C50073-2
C214	Mylar, 4700, 400V	C50197-25
C215	Mica, 3900, 5%, 500V	C50332-6
C216, 217	Ceramic, 1000, GMV, 500V	C50089-2
C218	Ceramic, .02uf, 20%, 500V	C50089-5
C219	Ceramic, 330, 1000V	C50183-5
C220	Ceramic, .02uf, 20%, 500V	C50089-5
C221, 222	Mylar, .047uf, 250V	C50197-52
C223, 224	Ceramic, 1000, 1000V	C50072-3
C225, 226	Ceramic, 2200, 1000V	C50072-5

## RESISTORS

In ohms, 5% tolerance, 1/8 W unless otherwise noted. K=Kilohms, M=Megohms.

Symbol	Description	Part No.
R200	Composition, 22M, 10%, 1/2 W	RC20BF226K

R201	Composition, 4.7K, 1/2 W	RC20BF472J
R202	Composition, 15K, 1/2 W	RC20BF153J
R203	Composition, 10M, 10%, 1/2 W	RC20BF106K
R204	Dep. Carbon, 1M	R12DC105J
R205	Dep. Carbon, 220K, 1/3 W	R33DC224J
R206	Dep. Carbon, 1.8M	R12DC185J
R207	Dep. Carbon, 1M	R12DC105J
R208	Dep. Carbon, 22K	R12DC223J
R209, 210,		
211, 212	Dep. Carbon, 33K	R12DC333J
R213, 214	Dep. Carbon, 100K	R12DC104J
R215	Potentiometer, 50K, MPX Separation	R50150-4
R216	Composition, 22M, 10%, 1/2 W	RC20BF226K
R217, 218	Dep. Carbon, 18K, 1/3 W	R33DC183J
R219, 220	Dep. Carbon, 15K, 1/3 W	R33DC153J
R221	Composition, 22M, 10%, 1/2 W	RC20BF226K
R222, 223	Dep. Carbon, 27K	R12DC273J
R224, 225	Dep. Carbon, 22K	R12DC223J
R226, 227,		
228, 229,		
230, 231	Dep. Carbon, 1M	R12DC105J

## MISCELLANEOUS

Symbol	Description	Part No.
CR100, 102,		
103	Diodes, Type 1112	V-1112
L100	Coil, low pass	L50210-30
L101	Coil, 5.25MH	L50334-1
L102, 103	Coil, 20MH	L50334-2
Z100	Transformer, 19Kc	ZZ50210-34
Z101	Coil, 38Kc	ZZ50210-33

# SCHEMATIC DIAGRAM • SPEAKER SYSTEMS

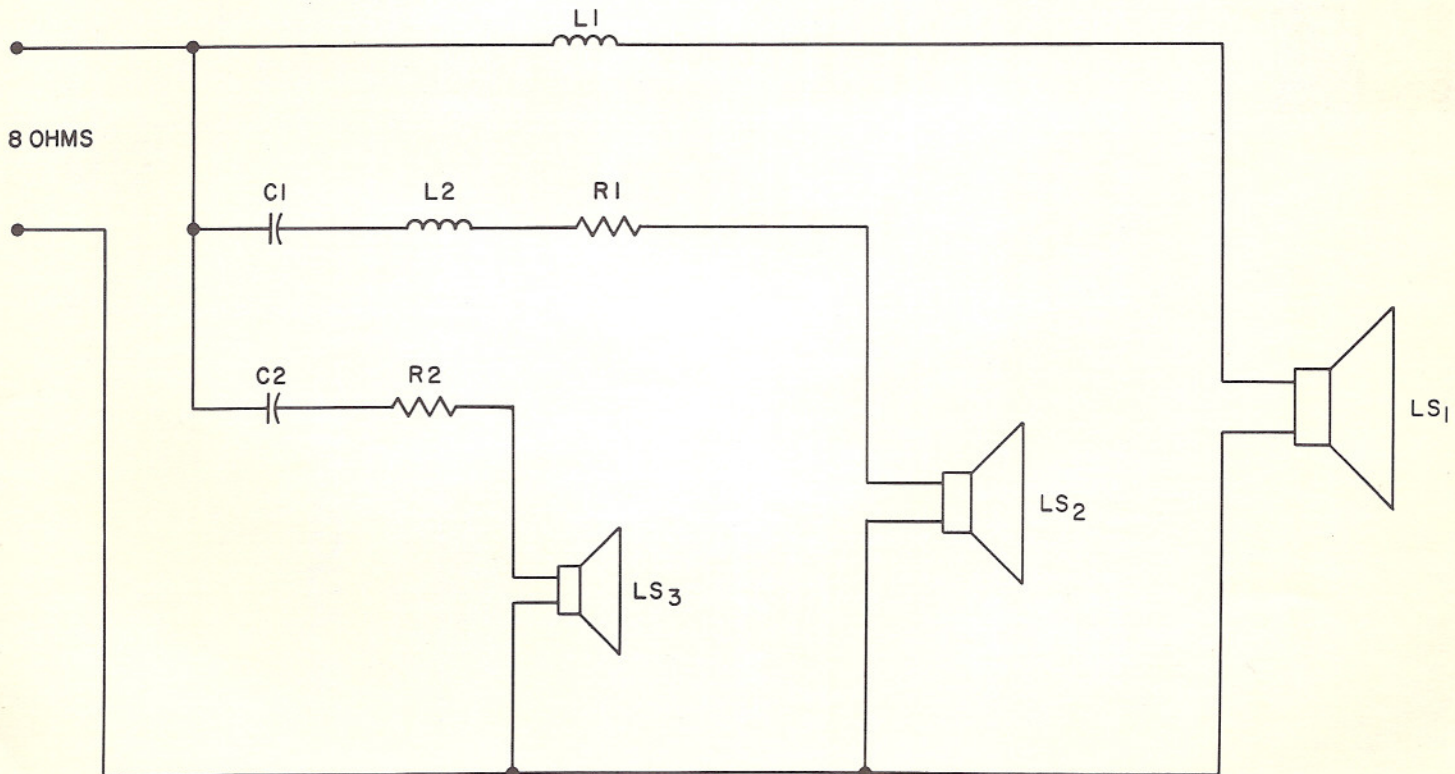

# ALIGNMENT INSTRUCTIONS

Read These Instructions With Extreme Care Before Attempting Alignment.

**CHASSIS:** Turn the station selector completely counterclockwise, without forcing. Dial pointer should be at zero index mark on logging scale. If not, reset the dial pointer. Disconnect the external antennas and the antenna link. Set Ferrite Loop to normal position, parallel to rear panel. When using an oscilloscope for alignment, set the output level controls for no overload, as shown by the proper waveform shape. Connect loads to main output and turn volume control to minimum.

**SIGNAL GENERATORS:** The signal generator equipment must be able to supply the following: FM RF modulated 30% ( $\pm 22.5$  KC deviation) at 400 cps; AM RF modulated 30% at 400 cps;

AM IF with 30KC sweep for AM bandwidth adjustment.

**INDICATOR:** DC VTVM, AC VTVM, and scope for alignment.

**ALIGNMENT:** Allow the chassis and test instruments to warm up for at least fifteen minutes. Adjust the line voltage for 117 volts AC, 50-60 cycles. Use fully insulated tools: a small screwdriver for all trimming capacitors; a K-Tran tool for Z1, Z2, Z3, Z4; a hex tool for L1, L2, L5, L6, L10, Z6 and Z5. For AM alignment, short AVC lead to ground.

**NOTE: For calibrating both the AM and FM, use as low an output voltage as possible from your signal generator.**

## AM ALIGNMENT

STEPS	CHASSIS			SIGNAL GENERATOR			INDICATOR		ALIGNMENT	
	AM BANDWIDTH	SELECTOR	STATION SELECTOR	COUPLING	FREQ.	MOD.	TYPE	CONNECTION	ADJUST	INDICATION
1	SHARP	AM	Point of no signal and no interference	AM Gen. connected to ungrounded tube shield over V3	455 KC	30% AM at 400 cps	AC VTVM	to Ch. B Rec. Output	Z2, Z4, top and bottom	Maximum voltage
2	BROAD	AM	Point of no signal and no interference	AM Gen. connected to ungrounded tube shield over V3	455 KC	30 KC sweep	Scope	to Ch. B Rec. Output	Z4 Bottom	Adjust slightly for symmetrical curve
3	SHARP	AM	600 KC	AM Gen. connected thru 220-uuf to the AM antenna terminal. Disconnect link between terminals.	600 KC	30% AM at 400 cps	AC VTVM	to Ch. B Rec. Output	L10, L5, L1	Maximum voltage
4	SHARP	AM	1400 KC	AM Gen. connected thru 220-uuf to the AM antenna terminal. Disconnect link between terminals.	1400 KC	30% AM at 400 cps	AC VTVM	to Ch. B Rec. Output	C7H, C7E C7D	Maximum voltage
5	Repeat steps 3 and 4 for proper dial calibration and maximum output.									
6		FM	Point of no signal and no interference	FM Gen. connected to ungrounded tube shield of V1	10.7 MC	None	DC VTVM	to test point 3	Z1, Z3, Z5 and Z6, top	Maximum negative voltage
7		FM	Point of no signal and no interference	FM Gen. connected to ungrounded tube shield of V1	10.7 MC	None	Connect hot lead of DC VTVM to MPX output, ground to junction of resistors (47K) connected in series from TSP3 to GND.		Z6, top	Zero reading on zero center scale
8		FM	90 MC	FM Gen. connected thru two 120-ohm carbon resistors in series with lead to antenna terminals DISTANCE.	90 MC	30% FM (22.5 KC Dev.) at 400 cps	DC VTVM	to TSP3 and scope to Ch. A. Rec. output	L9, L6 and L2	Check for sine waveform and adjust for maximum negative voltage
9		FM	106 MC	FM Gen. connected thru two 120-ohm carbon resistors in series with lead to antenna terminals DISTANCE.	106 MC	30% FM (22.5 KC Dev.) at 400 cps	DC VTVM	to TSP3 and scope to Ch. A. Rec. output	C25, C20	Check for sine waveform and adjust for maximum negative voltage
10	Repeat steps 8 and 9 for proper dial calibration and maximum output.									

## FM ALIGNMENT

**NOTE: For final calibration, use lowest possible generator voltage.**

CHASSIS SERIAL NUMBERS  
FROM 10001 TO 19999 INCLUSIVE

**SCHEMATIC DIAGRAM**

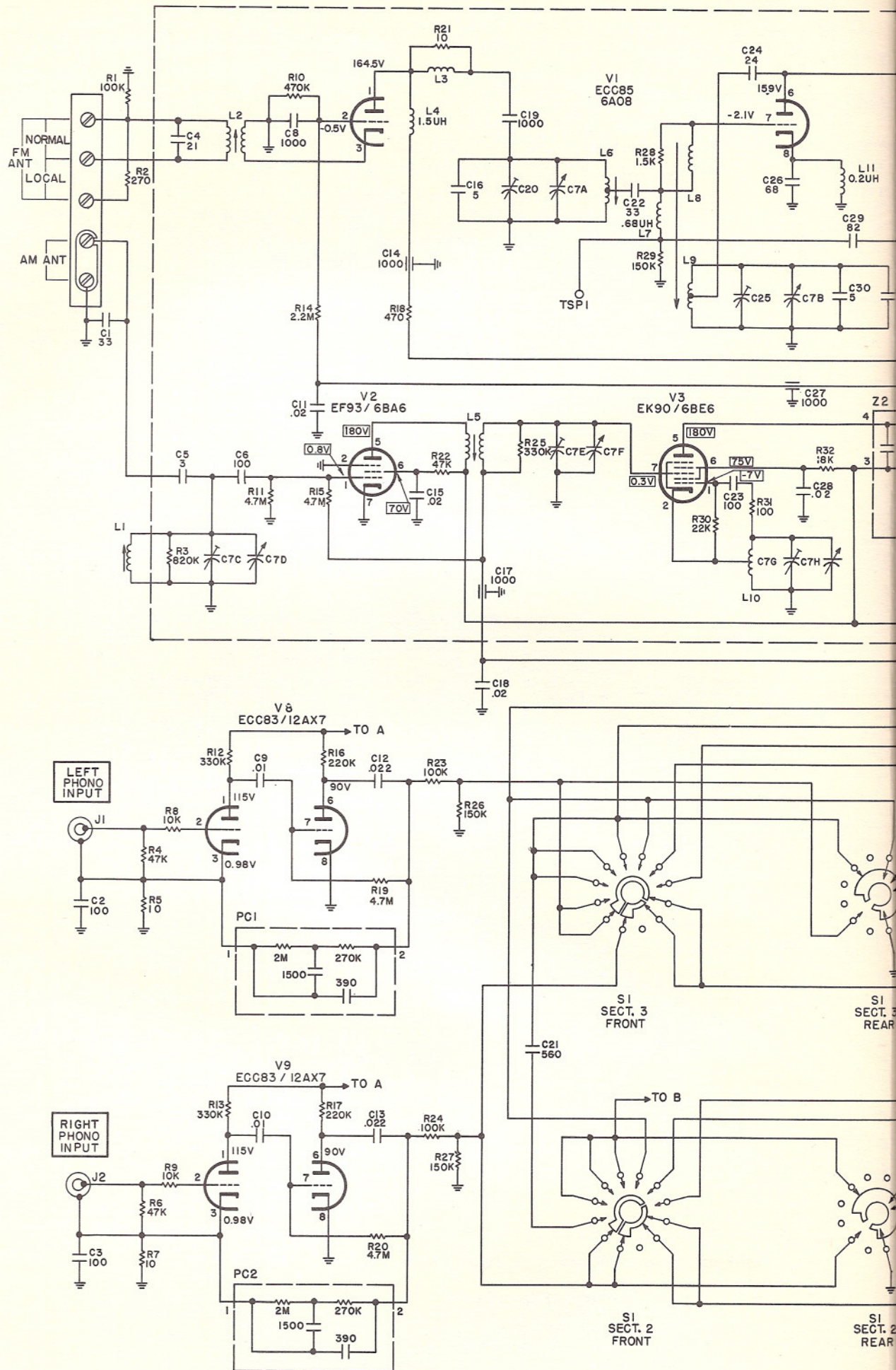

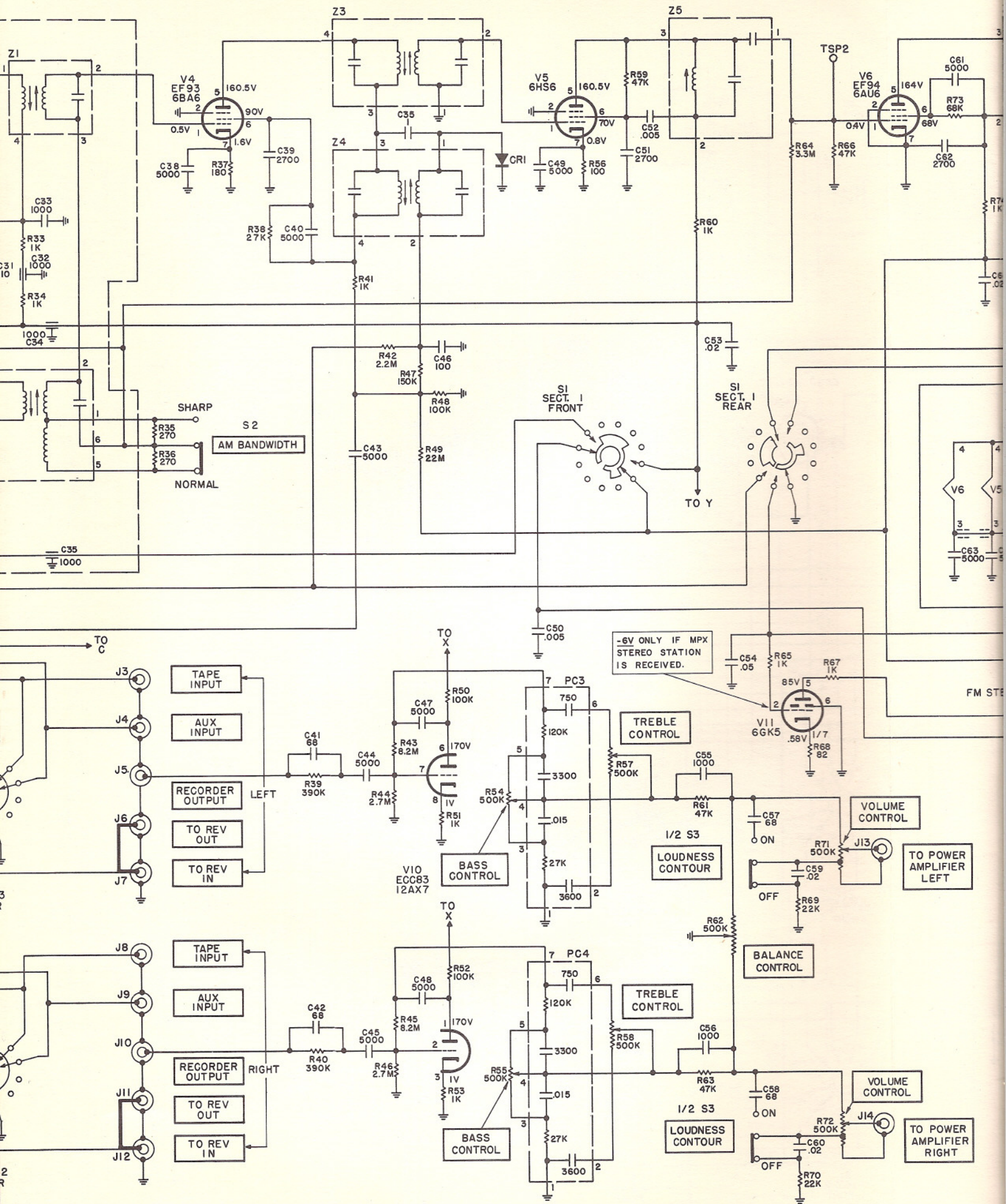

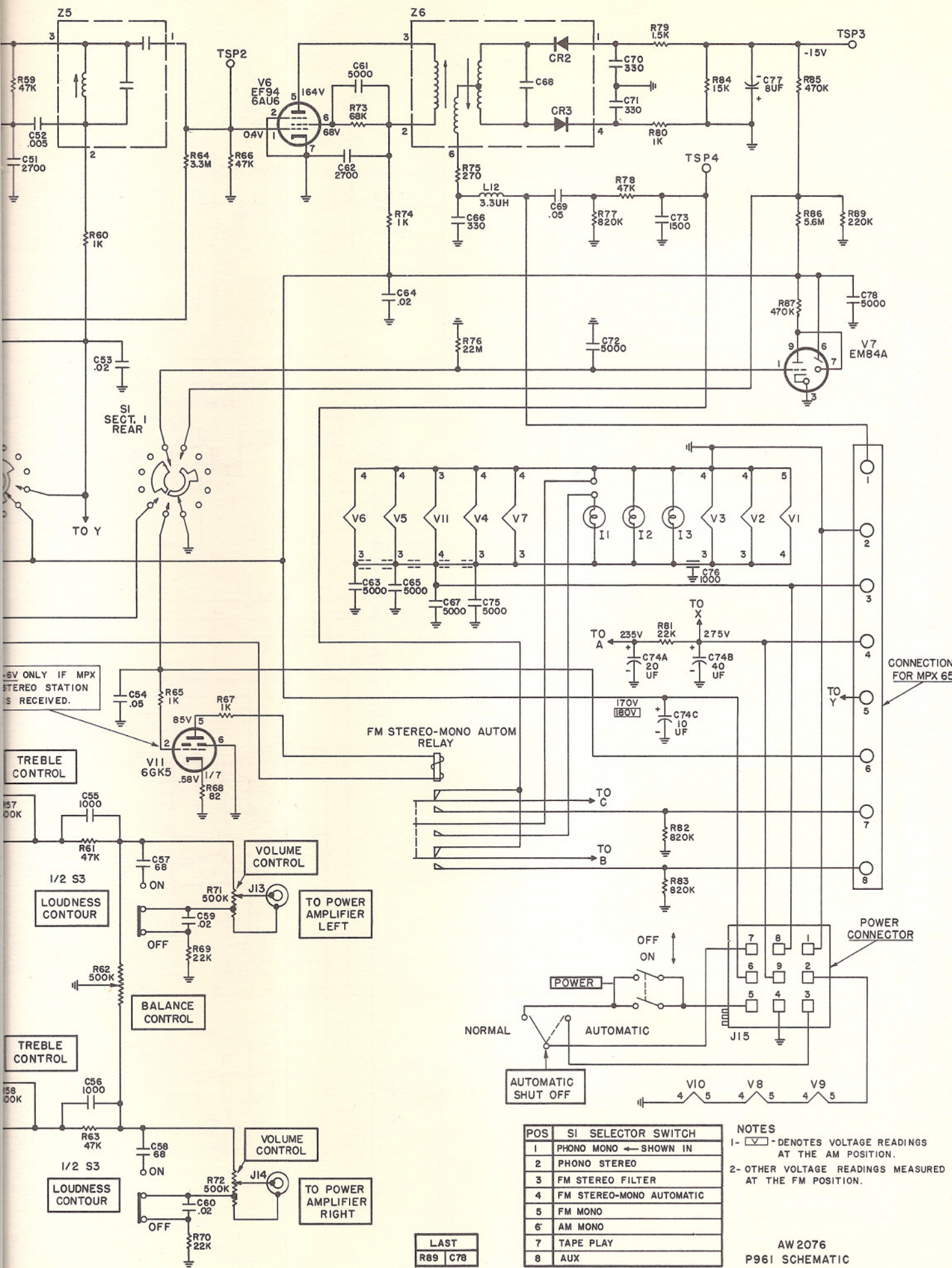

16V ONLY IF MPX STEREO STATION IS RECEIVED.

TREBLE CONTROL

LOUDNESS CONTOUR

TREBLE CONTROL

LOUDNESS CONTOUR

VOLUME CONTROL

TO POWER AMPLIFIER LEFT

BALANCE CONTROL

VOLUME CONTROL

TO POWER AMPLIFIER RIGHT

FM STEREO-MONO AUTOM RELAY

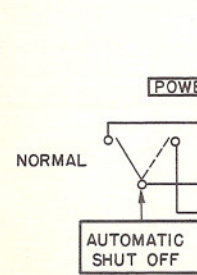

POS	SI SELECTOR SWITCH
1	PHONO MONO ← SHOWN IN
2	PHONO STEREO
3	FM STEREO FILTER
4	FM STEREO-MONO AUTOMATIC
5	FM MONO
6	AM MONO
7	TAPE PLAY
8	AUX

NOTES  
 1 - [ ] - DENOTES VOLTAGE READINGS AT THE AM POSITION.  
 2 - OTHER VOLTAGE READINGS MEASURED AT THE FM POSITION.

LAST  
 R89 C78

AW 2076  
 P961 SCHEMATIC

CONNECTION FOR MPX 65

POWER CONNECTOR

**SCHEMATIC DIAGRAM**  
 CHASSIS SERIAL NUMBERS  
 FROM 20001 TO 29999 INCLUSIVE

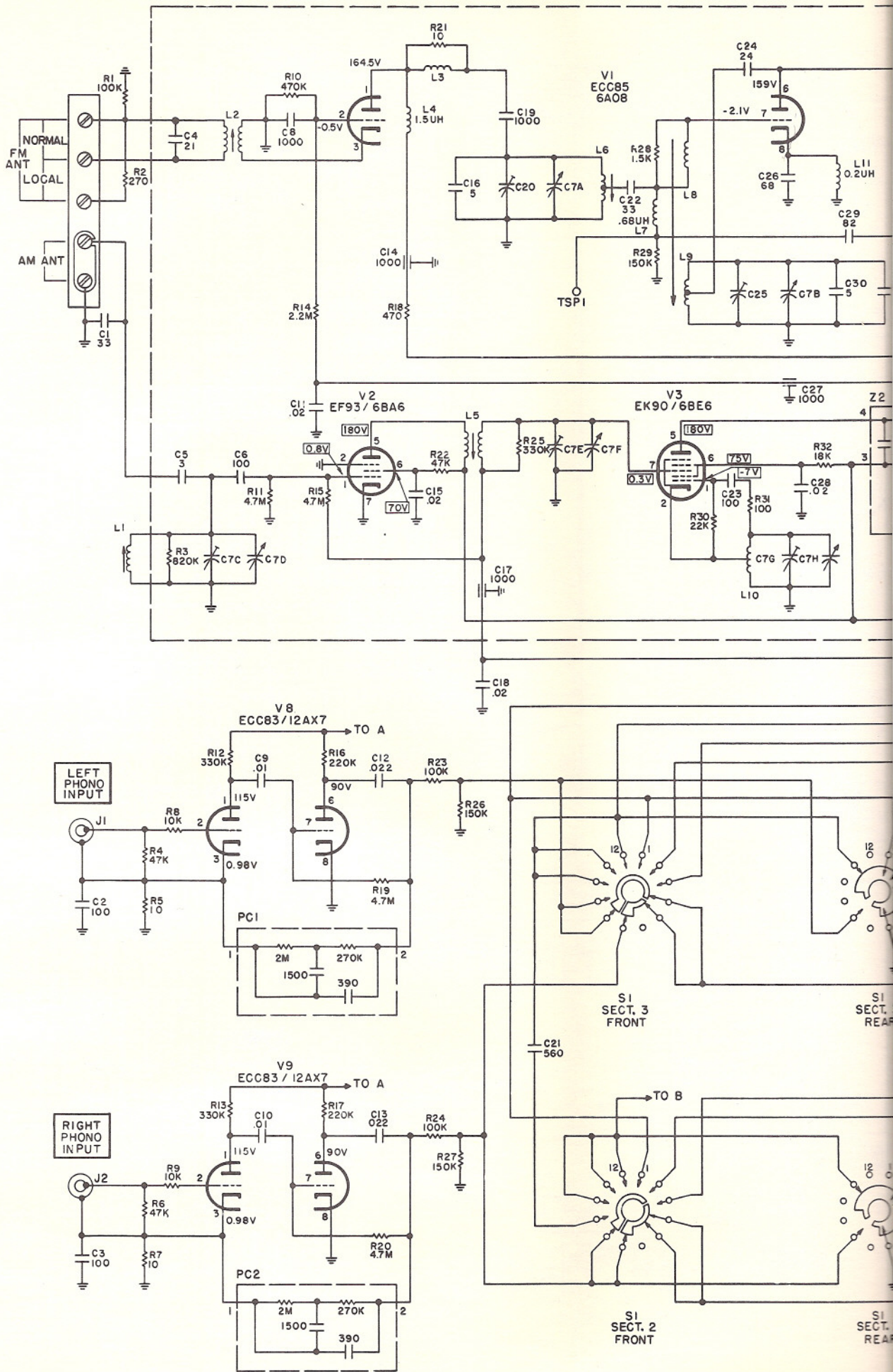



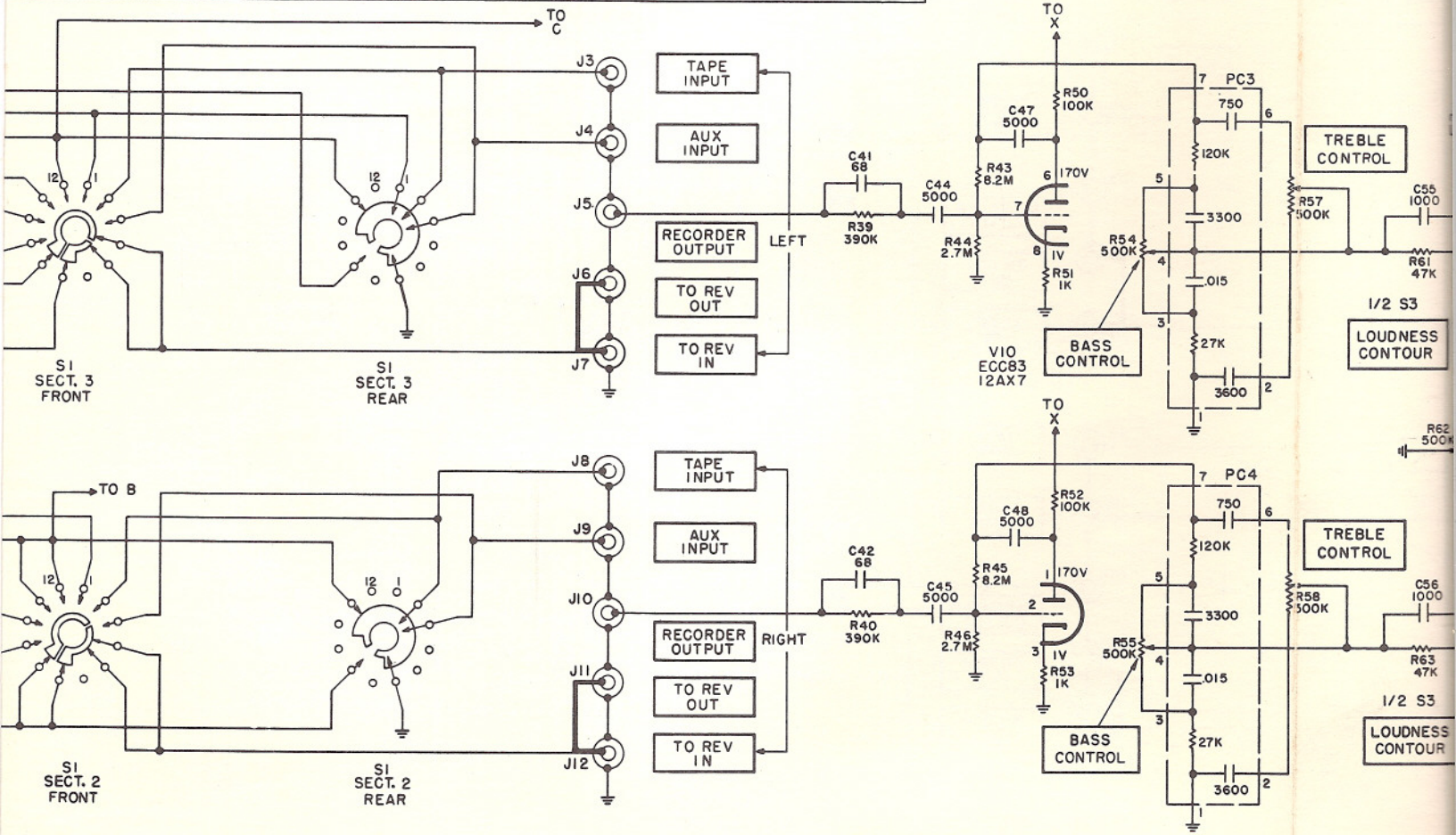
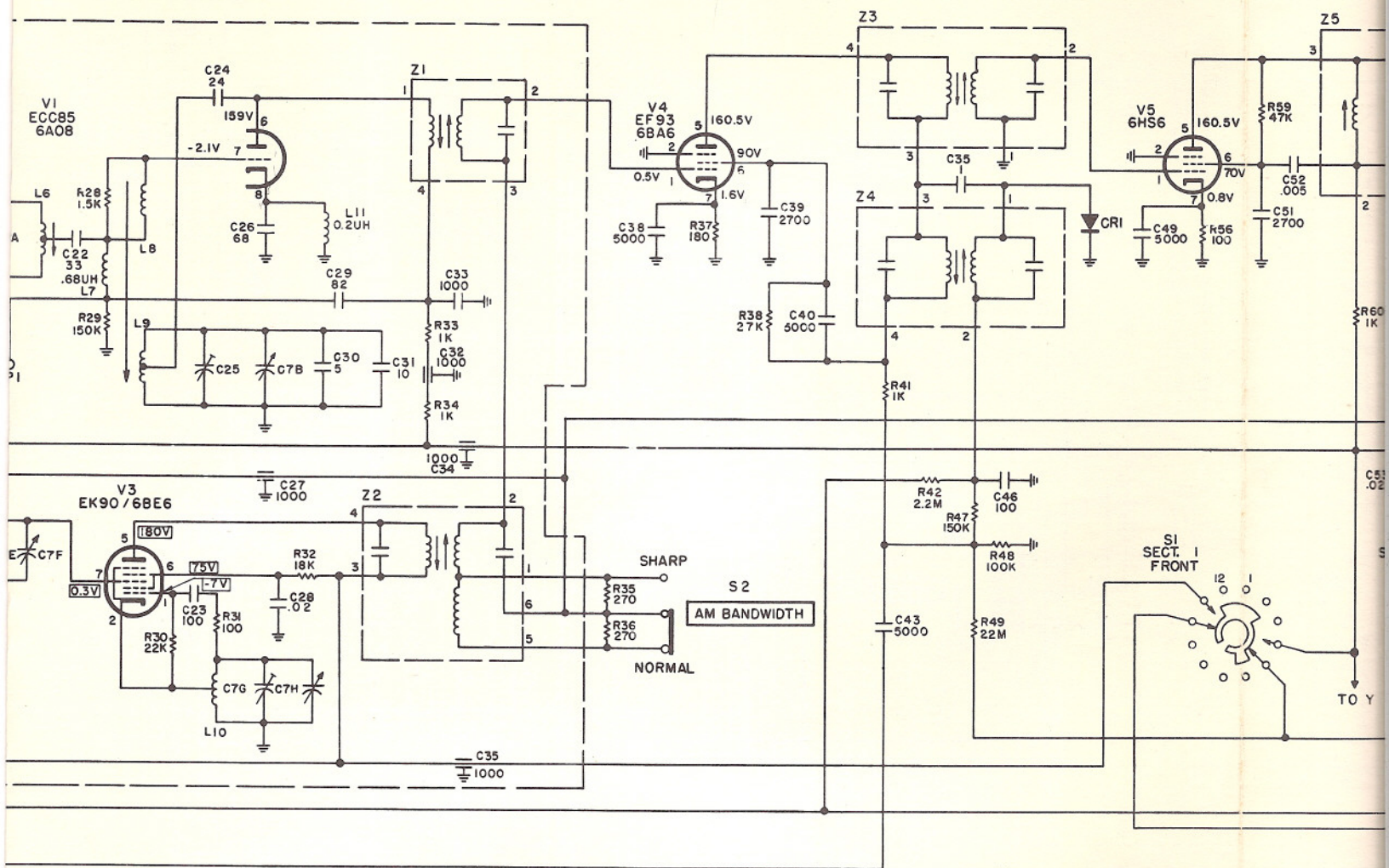

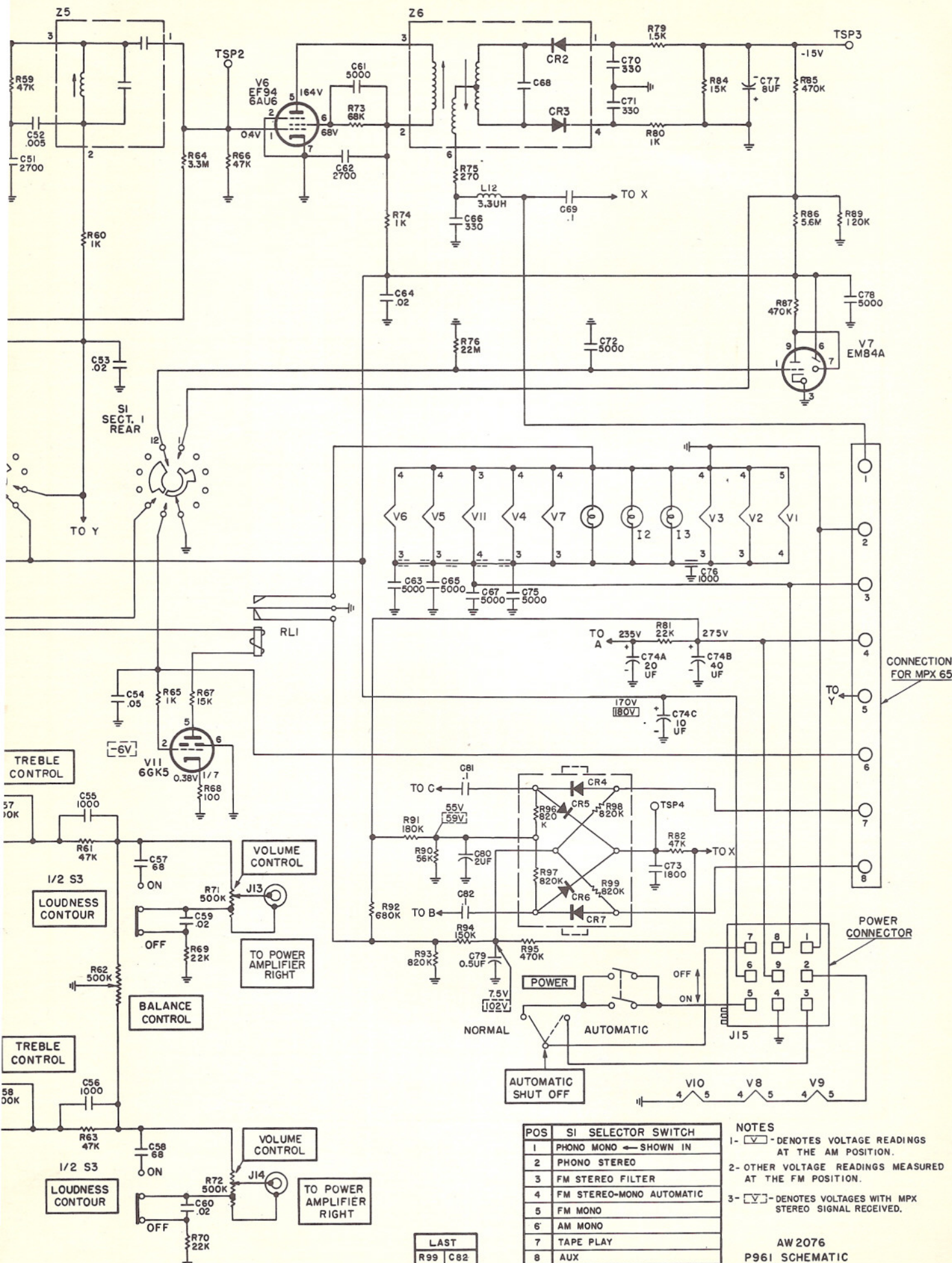

POS	SI SELECTOR SWITCH
1	PHONO MONO ← SHOWN IN
2	PHONO STEREO
3	FM STEREO FILTER
4	FM STEREO-MONO AUTOMATIC
5	FM MONO
6	AM MONO
7	TAPE PLAY
8	AUX

- NOTES
- 1- [ ] - DENOTES VOLTAGE READINGS AT THE AM POSITION.
  - 2- OTHER VOLTAGE READINGS MEASURED AT THE FM POSITION.
  - 3- [ ] - DENOTES VOLTAGES WITH MPX STEREO SIGNAL RECEIVED.

LAST  
R99 C82

AW 2076  
P961 SCHEMATIC



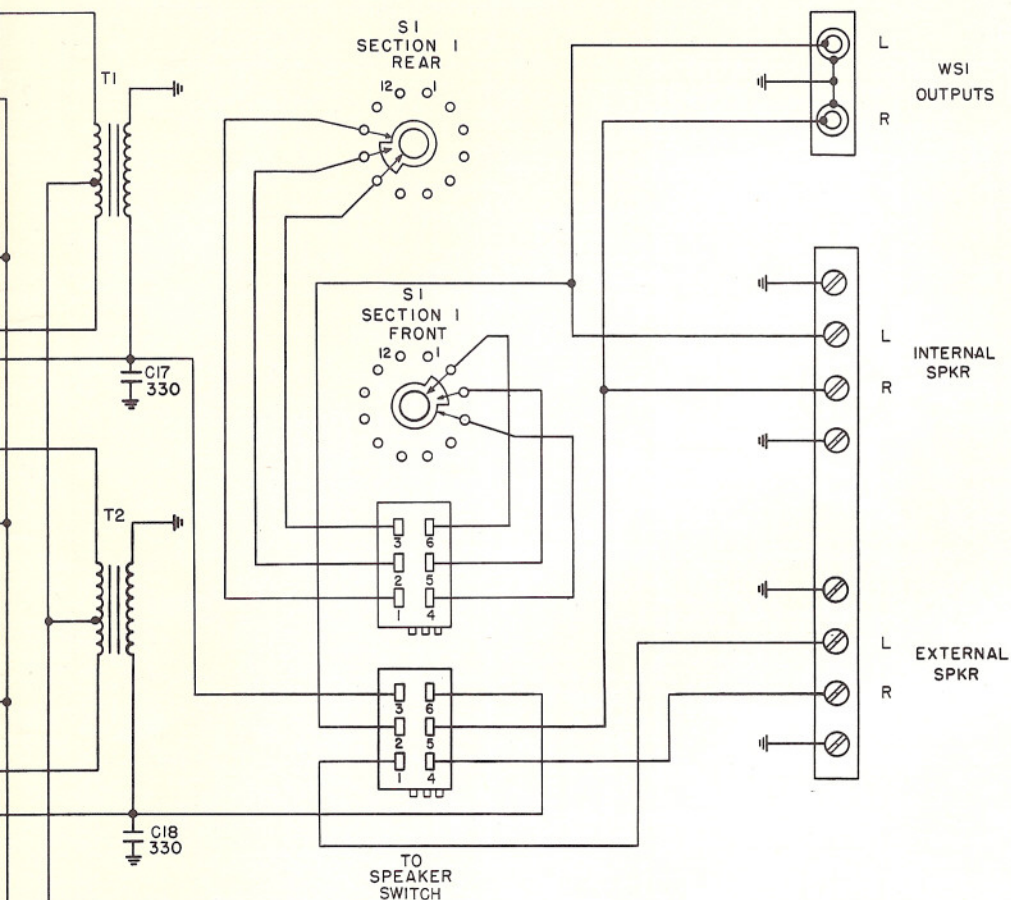

POS	S1
1	MAIN ← SHOWN IN
2	MAIN & REMOTE
3	REMOTE

LAST
R40   C19

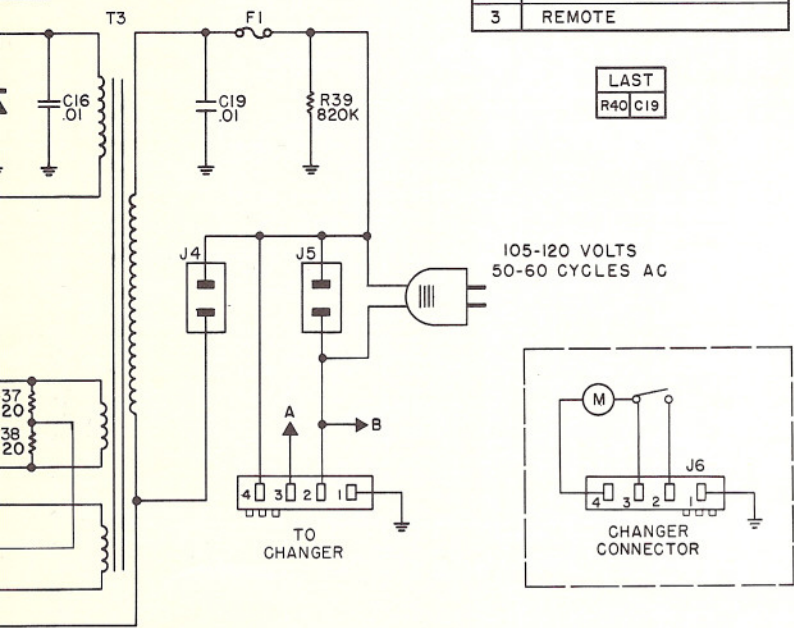

# SCHEMATIC DIAGRAM • MULTIPLEX SECTION

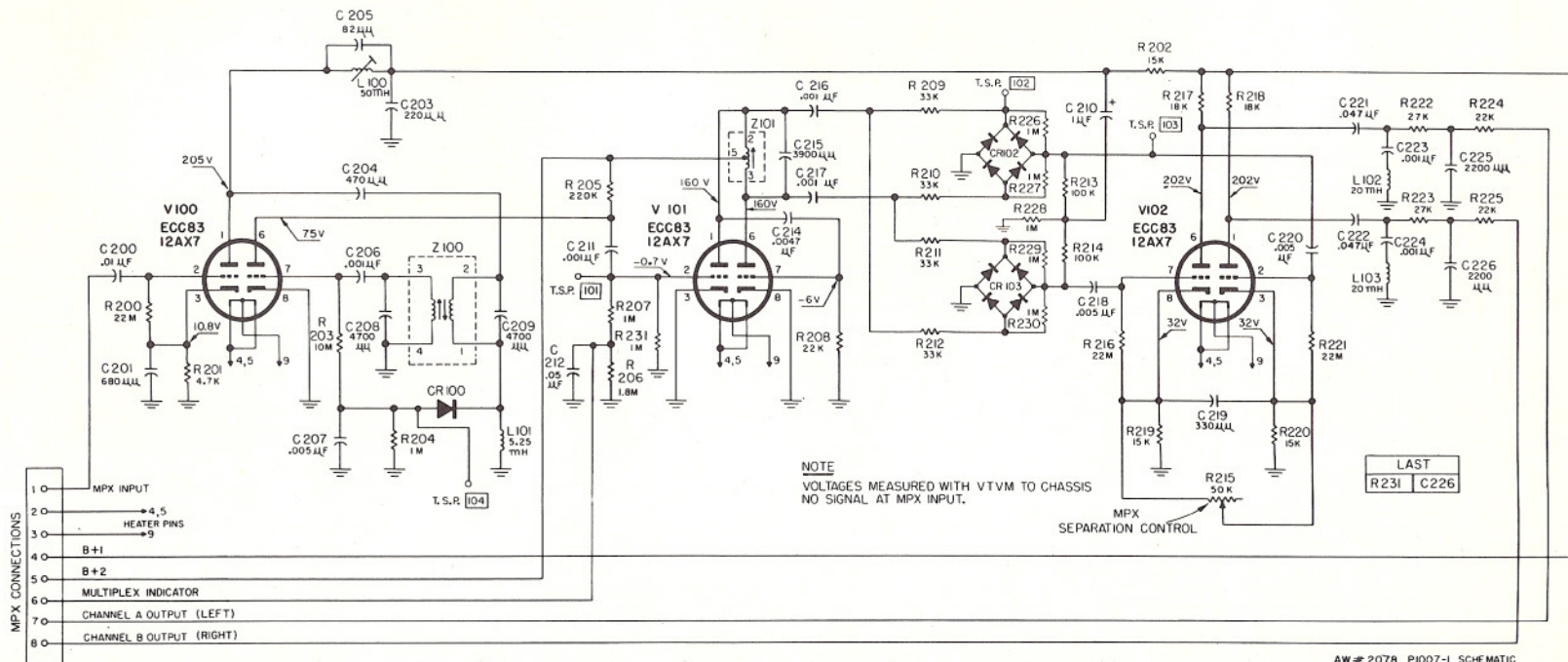

# TUBE LAYOUT • TUNER AND PREAMPLIFIER

ANTENNA TERMINALS



AM FM

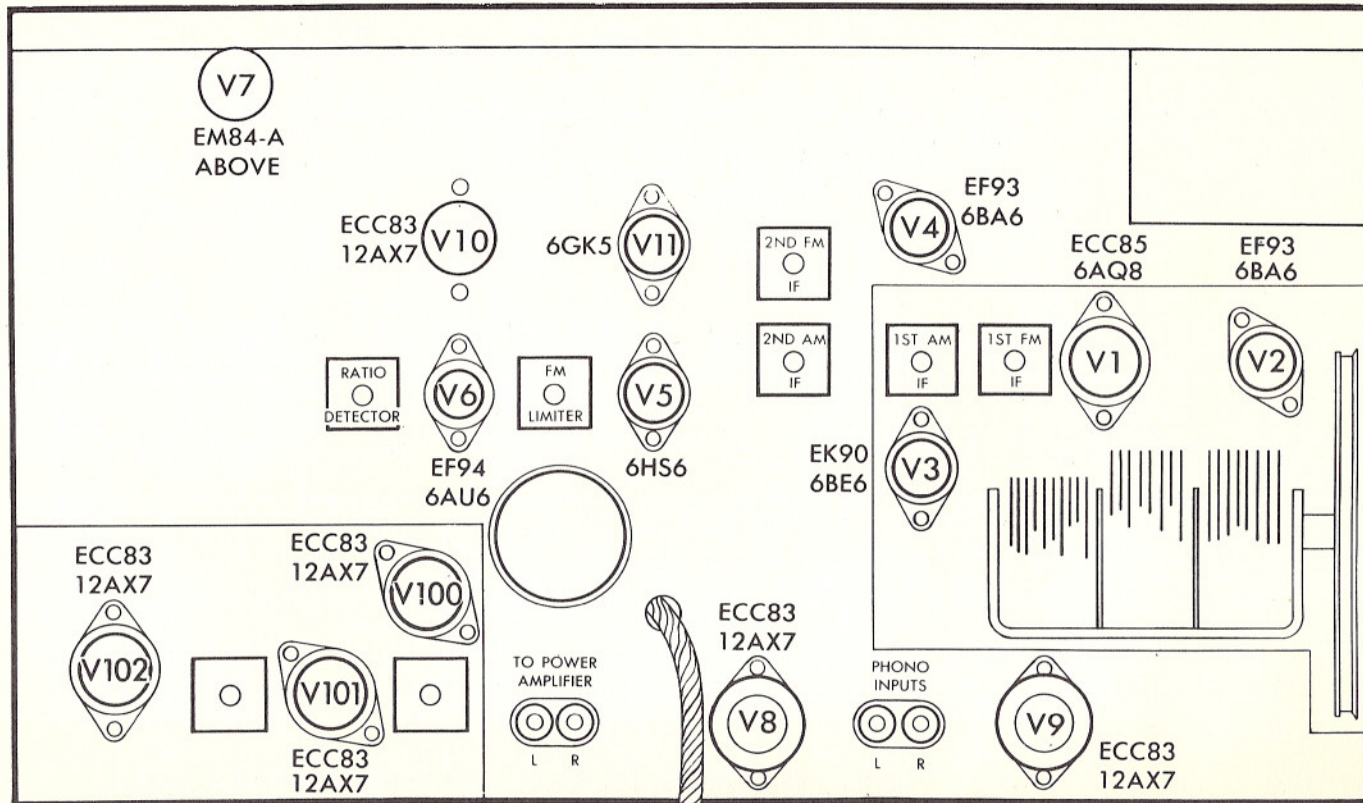
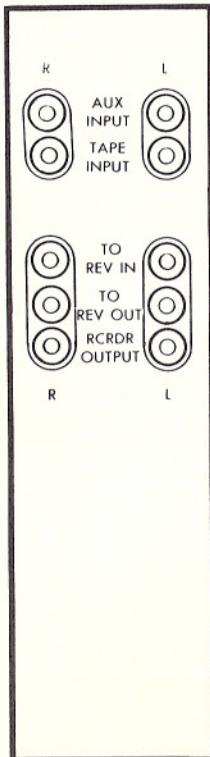

INS129

# ALIGNMENT INSTRUCTIONS • MULTIPLEX SECTION

STEPS	GENERATOR			INDICATOR	ALIGNMENT		
	CONNECTION	AUDIO FREQUENCY	RF MODULATION	TYPE & CONNECTION	ADJUST	INDICATION	NOTES
1	Audio oscillator connected to lug 1	80 KC—1 volt	None	AC VTVM to junction of C210 and R228	L100 (Use hex alignment tool)	Minimum voltage	
2	Multiplex generator audio output to lug 1 (See Note 1)	19 KC ( $\pm 5$ cps) pilot tone, 100 mv	None	DC VTVM to T.S.P. 101	Z100 top and bottom (Use hex alignment tool)	Maximum voltage	1
3	Same as Step 2	19 KC pilot tone, 50 mv	None	Scope horiz. input to 19 KC output of gen.; vert. input to junction of C216 and R209. External sweep	Z101 (Use K-tran alignment tool)	Stable 2:1 Lissajous pattern. Disregard phase of pattern	1
4	Same as Step 2	19 KC	None	Same as Step 3	Vary generator 19 KC output from 50 to 200 mv	Lissajous pattern should remain stationary over the entire 150 mv range	1, 2
5	Same as Step 2	1000 cps on left (A) channel only, 1 volt rms (2.8 P-P)	None	AC VTVM and scope vert. input to channel A output lug. Internal sweep. DC VTVM to T.S.P. 101	Z100 top (Use hex tool)	Maximum indication on AC VTVM. Clean 1000 cps waveform on scope	1, 3
6	Same as Step 2	1000 cps on right (B) channel only, 1 volt rms (2.8 P-P)	None	Same as Step 5	MPX separation R215	Minimum reading on AC VTVM should be at least 33 db below reading obtained in Step 5	1
7	Same as Step 2	Same as Step 6	None	Move scope input and AC VTVM to channel B output lug	-----	Note and record voltage reading on AC VTVM	1
8	Same as Step 2	1000 cps on left (A) channel only, 1 volt rms (2.8 P-P)	None	Same as Step 7	-----	AC VTVM reading should be at least 33 db below reading observed in Step 7	1
9	Same as Step 2	8000 cps on right (B) channel only, 1 volt rms (2.8 P-P)	None	Same as Step 7	-----	AC VTVM reading should be the same as observed in Step 7	1
10	Same as Step 2	8000 cps on left (A) channel only, 1 volt rms (2.8 P-P)	None	Same as Step 7	-----	AC VTVM reading should be at least 18 db below reading observed in Step 9	1
11	Repeat Steps 9 and 10 with scope and AC VTVM connected to channel A output lug, but start with 8000 cps applied to left channel for first reading, then switch to right channel for second reading.						
12	Multiplex generator RF output to 300-ohm antenna terminals	1000 cps on left (A) channel only	100% (75 KC Dev.) No pre-emphasis	Move scope input and AC VTVM to channel A output lug	-----	Note and record voltage reading on AC VTVM	4
13	Same as Step 12	1000 cps on right (B) channel only	Same as Step 12	Same as Step 12	R215	Minimum reading on AC VTVM should be at least 33 db below reading observed in Step 12	4
14	Same as Step 12	8000 cps on left (A) channel only	Same as Step 12	Same as Step 12	-----	AC VTVM reading should be 10 db below reading observed in Step 12	4
15	Same as Step 12	8000 cps on right (B) channel only	Same as Step 12	Same as Step 12	-----	AC VTVM reading should be 28 db below reading observed in Step 12	4

**NOTE:** The above procedure is based on the use of the FISHER Model 300 Multiplex Generator.

1 — In steps 2 through 11, the audio output of the Multiplex Generator should be connected to lug 1 of the multiplex sub-chassis through a 12,000 ohm, ½-watt, carbon resistor, and a 180 uuf capacitor should be connected between lug 1 and ground. The wiring from the MPX TEST jack on the main chassis to lug 1 must be disconnected during Steps 2 through 11.

2 — The vertical amplitude of the Lissajous pattern will increase slightly

as the generator output is increased. This is a normal occurrence.

3 — If DC VTVM reading falls below -9 volts when maximum reading is obtained on the AC VTVM, readjust bottom of Z100, then repeat Step 5. Repeat this procedure until maximum AC VTVM reading is obtained with DC VTVM reading greater than -9 volts.

4 — Tune the FISHER to the RF output frequency of the Multiplex Generator.



FISHER RADIO CORPORATION • NEW YORK

N986-103

© 1962 FISHER RADIO CORPORATION

PRINTED IN U.S.A.

552-GL120-102

# TUBE LAYOUT • AMPLIFIER

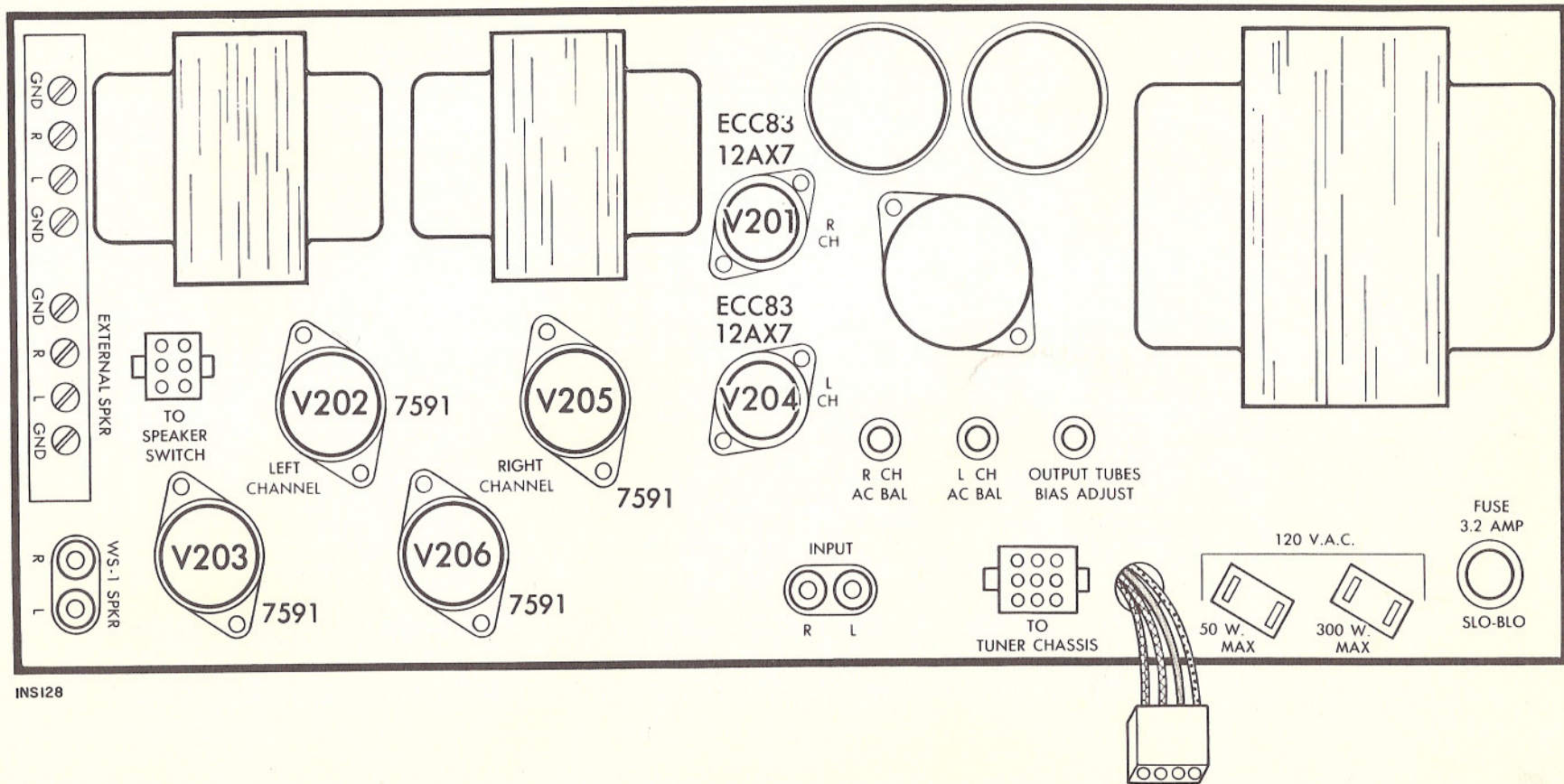

INS128