

Service Manual

Original

THE FISHER.

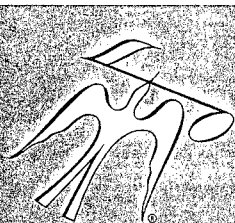
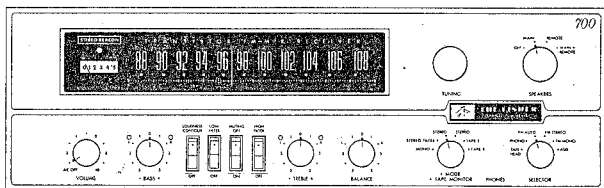

700-T

CHASSIS SERIAL NUMBERS
BEGINNING 10001

PRICE \$1.00

FISHER RADIO CORPORATION · LONG ISLAND CITY 1 · NEW YORK

Original

CAUTION: This is a FISHER precision high-fidelity instrument. It should be serviced only by qualified personnel — trained in the repair of transistor equipment and printed circuitry.

TEST EQUIPMENT REQUIRED

The following are needed to completely test and align modern high-fidelity instruments such as amplifiers, tuners and receivers.

Vacuum-Tube Voltohmmeter
(100-mV DC scale)
Audio Vacuum-Tube Voltmeter
(10-mV AC scale)
Oscilloscope (Flat to 100 kHz Minimum)
Audio (Sine-Wave) Generator
Intermodulation Distortion Analyzer
Harmonic Distortion Analyzer
AM/FM Signal Generator
Multiplex Generator (preferably with RF
output — FISHER Model 300 or equal)

10.7-MHz Sweep Generator
455-kHz Sweep Generator
Line Voltage Autotransformer
or Voltage Regulator
2 — Load Resistors, 4 or 8 Ohm, 50 Watt
2 — Full Range Speakers for Listening Tests
Stereo Source — Turntable or Tape Recorder
for Listening Tests
Soldering Iron with Small Tip
Fully Insulated from Power Line
Suction Desoldering Tool

PRECAUTIONS

Many of these items are included just as a reminder—they are normal procedures for experienced technicians. Shortcuts can be taken but often they cause additional damage — to transistors, circuit components or the printed-circuit board.

Soldering—A well-tinned, hot, clean soldering iron tip will make it easier to solder without damage to the printed-circuit board or the many circuit components mounted on it. It is not the wattage of the iron that counts — it is the heat available at the tip. Some 50-watt irons reach temperatures of 1,000° F — others will hardly melt solder. Small-diameter tips should be used for single solder connections — larger pyramid and chisel tips are needed for larger areas.

- When removing defective resistors, capacitors, etc., the leads should be cut as close to the body of the circuit component as possible. (If the part is not being returned for in-warranty factory replacement it may be cut in half — with diagonal-cutting pliers — to make removal easier.)
- Special de-soldering tips are made for unsoldering multiple-terminal units like IF transformers and electrolytic capacitors. By unsoldering all terminals at the same time the part can be removed with little chance of breaking the printed-circuit board.
- Always disconnect the chassis from the power line when soldering. Turning the power switch OFF is not enough. Power-line leakage paths, through the heating element, can destroy transistors.

Transistors—Never attempt to do any work on the transistor amplifiers without first disconnecting the AC linecord and waiting until the power supply filter-capacitors have discharged.

- Guard against shorts — it takes only an instant for a base-to-collector short to destroy that transistor and possibly others direct-coupled to it. (In the time it takes for a dropped machine screw, washer or even the screwdriver, to glance off a pair of socket terminals (or between a terminal and the chassis) a transistor can be ruined.)
- DO NOT bias the base of any transistor to, or near, the same voltage applied to its collector.
- DO NOT use an ohmmeter for testing transistors. The voltage applied through the test probes may be higher than the base-emitter breakdown voltage of the transistor.

Output Stage and Driver — Replacements for output and

driver transistors, if necessary, must be made from the same beta group as the original type. The beta group is indicated by a colored dot on the mounting flange of the transistor. Be sure to include this information, when ordering replacement transistors.

- If one output transistor burns out (open or shorts), always remove ALL output transistors in that channel and check the bias' adjustment, the control and other parts in the network with an ohmmeter before inserting a new transistor. All output transistors in one channel will be destroyed if the base-biasing circuit is open on the emitter end.
- When mounting a replacement power transistor be sure the bottom of the flange, the mica insulator and the surface of the heat sink are free of foreign matter. Dust and grit can prevent perfect contact reducing heat transfer to the heat sink. Metallic particles can puncture the insulator and cause shorts — ruining the transistor.
- Silicone grease must be used between the transistor and the mica insulator and between the mica and the heat sink for best heat conduction. (Use Dow-Corning DC-3 or C20194 or equivalent compounds made for power transistor heat conduction.)
- Use care when making connections to speakers and output terminals. Any frayed wire ends can cause shorts that may burn out the output transistors — they are direct-coupled to the speakers. To reduce the possibility of shorts at the speakers, lugs should be used on the exposed ends or at least the ends of the stranded wires should be tinned to prevent frayed wire ends. The current in the speakers and output circuitry is quite high. Poor contacts or small size wire can cause power losses in the speaker system. Use 14 or 16 AWG for long runs of speaker wiring.

Voltage Measurements—Voltage measurements are made with the line voltage adjusted to 117 volts and all readings are $\pm 10\%$. All voltages are DC, measured with a VTVM to ground, with no signal input unless otherwise noted. $\frac{1}{f}$ indicates 1-kHz audio voltages, measured with an audio AC VTVM to ground at various points from the phono input to the power amplifier output.

Alignment Procedures — Replacement of transistors and components in the front end, IF amplifier and multiplex decoder will normally not require realignment of these circuits. Realignment of these circuits, unless absolutely necessary, is not recommended. Do not attempt a realignment unless the required test equipment is available and the alignment procedure is thoroughly understood.

BECAUSE ITS PRODUCTS ARE SUBJECT TO CONTINUOUS IMPROVEMENT, FISHER RADIO CORPORATION RESERVES THE RIGHT TO MODIFY ANY DESIGN OR SPECIFICATION WITHOUT NOTICE AND WITHOUT INCURRING ANY OBLIGATION.

1381-1 10.7 MHz IF AMPLIFIER

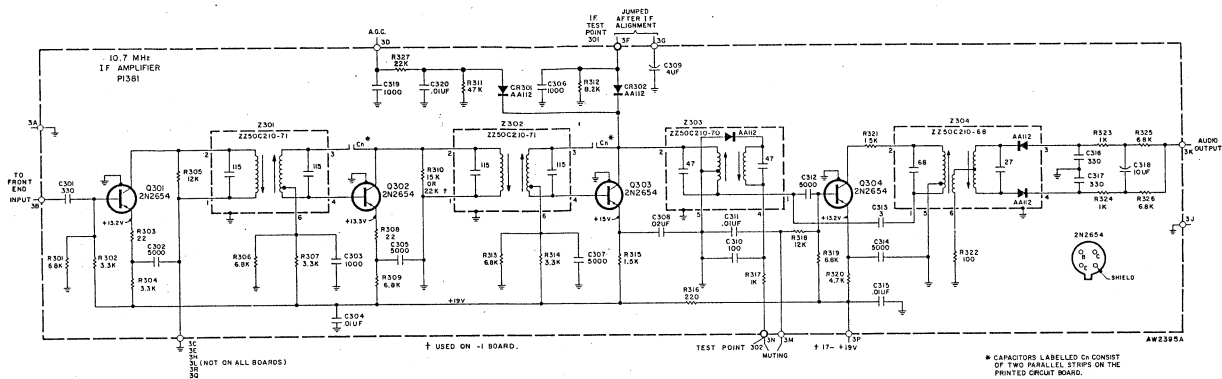

PARTS DESCRIPTION LIST

CAPACITORS		Part No.
C301	Ceramic, 330pF, 10%, 1000V	C50B569-1
C302	Ceramic, 5000pF, 20%, 500V	C50B567-2
C303	Ceramic, 1000pF, 10%, 1000V	C50B569-2
C304	Ceramic, 0.1uF, +80-20%, 500V	C50B570-1
C305	Ceramic, 5000pF, 20%, 300V	C50B567-2
C306	Ceramic, 1000pF, 20%, 1000V	C50B569-4
C307	Ceramic, 5000pF, 20%, 500V	C50B567-2
C308	Ceramic, 0.2uF, +80-20%, 100V	C50B570-2
C309	Electrolytic, 4uF, 35V	C50483-1
C310	Ceramic, 100pF, 10%, N1500, 1000V	C50B568-3
C311	Ceramic, 0.1uF, +80-20%, 500V	C50B570-1
C312	Ceramic, 5000pF, 20%, 500V	C50B567-2
C313	Ceramic, 3pF, 10%, NP0, 1000V	C50970-28
C314	Ceramic, 5000pF, 20%, 500V	C50B567-2
C315	Ceramic, 0.1uF, +80-20%, 500V	C50B570-1
C316, 317	Ceramic, 330pF, 10%, 1000V	C50B569-1
C318	Electrolytic, 10uF, 35V	C50483-2
C319	Ceramic, 1000pF, 20%, 1000V	C50B569-4
C320	Ceramic, 0.1uF, +80-20%, 500V*	C50B570-1

RESISTORS		Part No.
R301	6.8K	R120C682J
R307	3.3K	R120C332J
R308	22	R120C220J
R309	6.8K	R120C682J
R310	15K	R120C153J
R311	47K	R120C473J
R312	8.2K	R120C822J
R313	6.8K	R120C682J
R314	3.3K	R120C332J
R315	1.5K	R120C153J
R316	220	R120C221J
R317	1K	R120C102J
R318	12K	R120C123J
R319	6.8K	R120C682J
R320	4.7K	R120C472J
R321	1.5K	R120C153J
R322	100	R120C101J
R323, 324	1K	R120C102J
R325, 326	6.8K	R120C682J
R327	2K	R120C223J

MISCELLANEOUS		Part No.
CR301, 302	Diode, AA112	V50266-16
Z303	Transformer, I. F.	Z250C210-71
Z304	Coil, Limiter	Z250C210-70
Q301, 302	Transistor 2N2654	TR2N2654
Q303, 304	Transistor 2N2654	AS0616

MISCELLANEOUS		Part No.
CR301, 302	Diode, AA112	V50266-16
Z303	Transformer, I. F.	Z250C210-71
Z304	Coil, Limiter	Z250C210-70
Q301, 302	Transistor 2N2654	TR2N2654
Q303, 304	Transistor 2N2654	AS0616

* Used on -1 board.

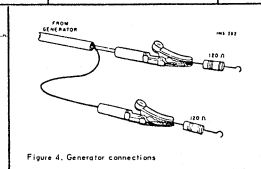
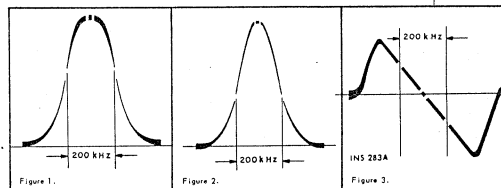
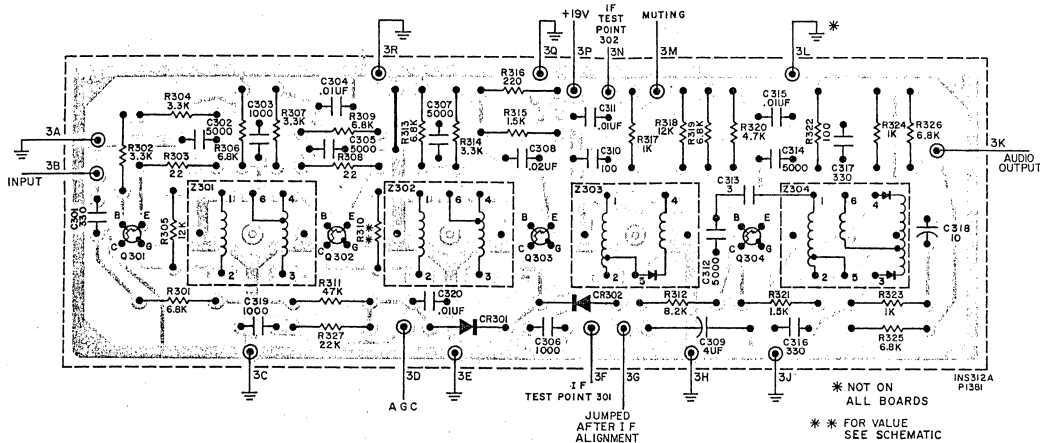

Figure 4. Generator connections

87-10101-101

1381-1 10.7 MHz IF AMPLIFIER

BOARD VIEWED FROM COMPONENT SIDE



IF ALIGNMENT

- Connect 10.7-MHz (Mc) sweep generator to TP751 on front end. Disconnect jumper between terminals 3F and 3G on IF board. Connect scope vertical input through 220K resistor to TP301.
- NOTE: Connect ground lead of generator to ground near TP751 and ground of scope closest to scope input.
- Adjust generator output voltage and frequency to observe IF response curve. Use as low a generator output as possible. Measure voltage of TP301 with DC VTVM during alignment and readjust generator output to keep meter reading from -1.4 to -2.0 VDC maximum.
- Define top core of Z303 outdoors.
- Align bottom core of Z301, top and bottom cores of Z302, Z301 and Z751 for maximum gain and symmetry—see Figure 1. Repeat alignment.
- Reconnect jumper between terminals 3F and 3G. Disconnect wire from TP302 (terminal 3N) and connect scope vertical input through 220K resistor to TP302.

- Align top core of Z303 for maximum gain and symmetry—see Figure 2.
- Disconnect scope and reconnect wire to TP302. Connect DC VTVM to TP302.
- Set generator output to 10.7 MHz (Mc) with no sweep. Vary generator voltage from minimum to maximum; reading on DC VTVM should increase with increase in signal.
- Connect DC VTVM across resistor R4. Vary generator voltage from minimum to maximum; reading on DC VTVM should decrease with increase in signal.
- Set generator voltage to 200mV. Adjust Meter Adjust Pot. R14 for tuning meter reading of 4.
- Connect scope vertical input through 220K resistor to terminal 3K.
- Set generator for sweep and adjust generator output voltage to observe ratio detector response. Use as low a generator output as possible.
- Adjust top and bottom cores of Z304 for maximum gain; readjust top core for best linearity—see Figure 3.

FM TUNING METER CALIBRATION

- Connect on FM generator to the NORM antenna terminals. Use a 120-ohm composition resistor in series with each lead from the generator.
- Set FM generator frequency and TUNING dial pointer to 90 MHz (Mc). Set generator output to 20 mV, 122.5 kHz (kc) deviation with 400 Hz (cps).
- Adjust top core of Z303 for maximum reading on tuning meter.
- Increase generator output to 200 mV. Adjust Meter Adjust Pot. R14 for meter reading of 4.5.

FM MUTING ADJUSTMENT

- Set MUTING switch to OFF.
- Connect on FM generator to the NORM antenna terminals. Use a 120-ohm composition resistor in series with each lead from the generator.
 - Connect AC VTVM to LEFT or RIGHT CHANNEL RCDR HIGH jack.
 - Set FM generator frequency and TUNING dial pointer to 90 MHz (Mc). Set generator output to 20 mV, 122.5 kHz (kc) deviation with 400 Hz (cps).
 - Adjust TUNING knob for maximum reading on tuning meter. Note reading on AC VTVM.
 - Set MUTING switch to ON. Adjust Muting Adjust Pot. R16 for reading on AC VTVM 1 to 5 dB lower than that previously noted.
 - Reduce generator voltage to zero-no signal (400 Hz modulation) or noise should be indicated on AC VTVM at RCDR HIGH jack.

* NOT ON ALL BOARDS
** FOR VALUE SEE SCHEMATIC

1531 MULTIPLEX DECODER

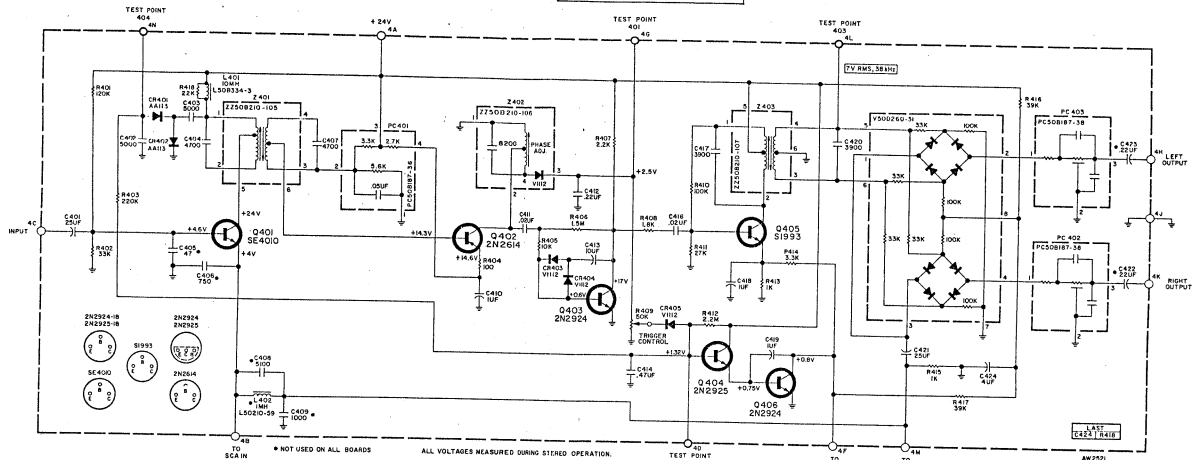

PARTS DESCRIPTION LIST

CAPACITORS			RESISTORS			MISCELLANEOUS		
Symbol	Description	Part No.	Symbol	Description	Part No.	Symbol	Description	Part No.
C401	Electrolytic, 25uF, 15V	C508637-6	R401	120K	RC20BF124K	CR401, 402	Diode, AA113	V50050-22
C402, 403	Ceramic, 5000pF, 20%, 50V	C508567-2	R402	33K	RC20BF333K	CR403-405	Diode, 1112	V1112
C404	Polystyrene, 4700pF, 5%, 33V	C508636-22	R403	220K	RC20BF224K	L401	Coil, MPX Filter Choke, 10mH	L50834-3
C405	Ceramic, 47pF, 10%, N330, 1000V	C508568-20	R404	100	RC20BF101K	L402	Choke, SCA Filter	L50010-59
C406	Ceramic, 750pF, 10%, 1000V	C508567-64	R405	10K	RC20BF101K	PC401	Printed Circuit	PC508187-36
C407	Polystyrene, 4700pF, 5%, 33V	C508636-23	R406	1.5M	RC20BF150K	PC402, 403	Printed Circuit	PC508187-38
C408	Polystyrene, 5100pF, 5%, 33V	C508636-27	R407	2.2K	RC20BF220K	Q401	Transistor, 401 D	TR4010-2
C409	Ceramic, 1000pF, 10%, 1000V	C508569-3	R408	1.8K	RC20BF155K	Q402	Transistor, 2N2614	TR2N2614
C410	Electrolytic, 1uF, 70V	C508637-2	R409	50K, 30%, Trigger Control	RC20BF182K	Q403	Transistor, 2N2924	TR2N2924-18
C411	Ceramic, .02uF, +80-20%, 100V	C508570-2	R410	100K	RC20BF182K	Q404	Transistor, 2N2925	TR2N2925-18
C412	Mylar, 22uF, 10%, 100V	C508638-16	R411	22K	RC20BF102K	Q405	Transistor, 51903	TR51903
C413	Electrolytic, 10uF, 25V	C508637-4	R412	2.2M	RC20BF225K	Z401	Transformer, 194Hz	Z508210-105
C414	Mylar, .47uF, 10%, 100V	C508638-17	R413	1K	RC20BF102K	Z402	Coil, 104Hz	Z508210-106
C415	-Deleted-	---	R414	3.3K	RC20BF102K	Z403	Transformer, 38kHz	Z508210-107
C416	Ceramic, .02uF, +80-20%, 100V	C508570-2	R415	1K	RC20BF102K	---	Dual Chopper	V500260-01
C417	Silver Mica, 3900pF, 5%, 100V	C508571-1	R416, 417	Dep. Carbon, 39K, 5%, 1/8W	R120C93J			
C418	Electrolytic, 1uF, 70V	C508637-2						
C419	Tant. Electrolytic, 1uF, 20%, 25V	C508440-1						
C420	Silver Mica, 3900pF, 5%, 100V	C508571-1						
C421	Electrolytic, 25uF, 15V	C508637-6						
C422, 423	Tant. Electrolytic, 22uF, 20%, 25V	C508440-6						
C424	Electrolytic, 4uF, 35V	C508483-1						

1531 (10/11/64)

MULTIPLEX ALIGNMENT

Two methods of aligning the multiplex decoder are given. The preferred procedure uses a multiplex generator with RF and 19 kHz outputs and with 1 kHz modulation, such as the Fisher Model 300 Multiplex Generator. This is the better method of alignment since the front and IF stages are also checked through the use of this procedure. An alternate procedure for use with multiplex generators not having an RF output is also given.

PREFERRED ALIGNMENT PROCEDURE

- Set MUTING switch to OFF and SELECTOR switch to FM AUTO.
- Connect MPX generator to the LOC antenna terminals. Use two 120-ohm composition resistors in series with the generator leads.
- Follow procedures given in Table 1 below.
- NOTE: Check the alignment of the IF amplifier before aligning the MPX decoder. Poor IF alignment can make proper multiplex adjustment impossible.

ALTERNATE ALIGNMENT PROCEDURE

- Set MUTING switch to OFF and SELECTOR switch to FM AUTO.
- Disconnect wire going to connection 4C on the multiplex board. Connect MPX generator to connection 4C.
- Follow procedures given in Table 2 below.
- After alignment is complete, disconnect MPX generator and reconnect lead coming from connection 3K on the IF board to connection 4C on the multiplex board.

1531 MULTIPLEX DECODER

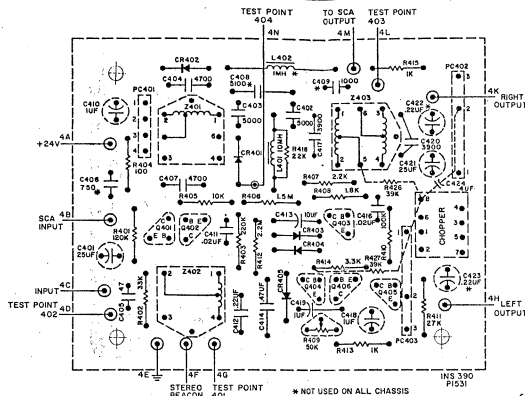

BOARD VIEWED FROM COMPONENT SIDE

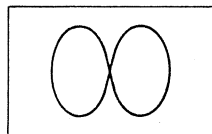

FIGURE 1. Lissajous pattern for MPX alignment.

TABLE 1

MULTIPLEX ALIGNMENT USING RF MULTIPLEX SIGNAL

STEP	GENERATOR MODULATION	RF DEV.	INDICATOR TYPE AND CONNECTION	ALIGNMENT	
				ADJUST	INDICATION
1	19kHz (kc) pilot only.	±7.5kHz (kc)	DC VTVM to TP401	Z401 top & bottom, Z402	Maximum DC VTVM reading.
2	Short connection 4F to ground.	-	-	-	Stereo Beacon should light.
3	Connect portion of 19kHz (kc) generator output to scope horizontal input.	no mod.	Scope vertical input through 1 megohm resistor to TP403; scope set for external sweep.	Z403 top	Stable Lissajous pattern 2:1 (Figure 1) as slow moving as possible.
4	Same as Step 3.	no mod.	Same as Step 3	Z403 bottom	Maximum scope amplitude; adjust Z403 top as necessary for slowest moving Lissajous.
5	Disconnect connection 4F from ground.	-	-	-	-
6	Composite MPX signal 1kHz (kc) on left channel only.	±75kHz (kc)	Audio (AC) VTVM and scope input to left channel output on preamp board.	Z402	Maximum audio AC VTVM reading; clean 1kHz (kc) sine wave on scope.
7	Composite MPX signal 1kHz (kc) on right channel only.	±75kHz (kc)	Same as Step 6.	Separation Control*	Minimum audio AC VTVM reading—at least 30 db below reading in Step 6.
8	Same as Step 7.	±75kHz (kc)	Audio (AC) VTVM and scope input to right channel output on preamp board.	-	Same audio AC VTVM reading as obtained in Step 6 (±2 db); clean 1kHz (kc) sine wave on scope.
9	Same as Step 6.	±75kHz (kc)	Same as Step 6.	-	Minimum audio AC VTVM reading—at least 30 db below reading in Step 8.
10	19kHz (kc) pilot only.	±3.5kHz (kc)	DC VTVM to connection 4F.	Trigger Control	Stereo Beacon lights up with 0.8 V reading on DC VTVM.

*NOTE: Separation Control is located on preamplifier board.

TABLE 2

MULTIPLEX ALIGNMENT USING COMPOSITE MULTIPLEX SIGNAL

STEP	GENERATOR MODULATION	LEVEL (RMS)	INDICATOR TYPE AND CONNECTION	ALIGNMENT	
				ADJUST	INDICATION
1	19kHz (kc) pilot only.	Vary 0 to 50mV	DC VTVM to TP401	Z401 top & bottom, Z402	Maximum DC VTVM reading.
2	Short connection 4F to ground.	-	-	-	Stereo Beacon should light.
3	Connect portion of 19kHz (kc) generator output to scope horizontal input.	Vary 0 to 50mV	Scope vertical input through 1 megohm resistor to TP403; scope set for external sweep.	Z403 top	Stable Lissajous pattern 2:1 (Figure 1) as slow moving as possible.
4	Same as Step 3.	Vary 0 to 50mV	Same as Step 3.	Z403 bottom	Maximum scope amplitude; adjust Z403 top as necessary for slowest moving Lissajous.
5	Disconnect connection 4F from ground.	-	-	-	-
6	Composite MPX signal 1kHz (kc) on left channel only.	100mV (560mV P-P)	Audio (AC) VTVM and scope input to left channel output on preamp board.	Z402	Maximum audio AC VTVM reading; clean 1kHz (kc) sine wave on scope.
7	Composite MPX signal 1kHz (kc) on right channel only.	100mV (560mV P-P)	Same as Step 6.	Separation Control*	Minimum audio AC VTVM reading—at least 30 db below reading in Step 6.
8	Same as Step 7.	100mV (560mV P-P)	Audio (AC) VTVM and scope input to right channel output on preamp board.	-	Same audio AC VTVM reading as obtained in Step 6 (±2 db); clean 1kHz (kc) sine wave on scope.
9	Same as Step 6.	100mV (560mV P-P)	Same as Step 6.	-	Minimum audio AC VTVM reading—at least 30 db below reading in Step 8.
10	19kHz (kc) pilot only.	Vary 0 to 50mV	DC VTVM to connection 4F.	Trigger Control	Stereo Beacon lights up with 0.8 V reading on DC VTVM.

*NOTE: Separation Control is located on preamplifier board.

PARTS DESCRIPTION LIST

CAPACITORS		
Symbol	Description	Part No.
C201, 202	203, 204	
	Electrolytic, 1 μ F, 70V	C50B637-2
C207, 208	205, 206	
	Ceramic, 680pF, 10%, 1000V	C50B549-2
C209, 210	209	
	Mylar, .33 μ F, 10%, 250V	C50B638-10
C211, 212	213, 214	
	*Tant. Electrolytic, 1 μ F, 20%, 25V	C50C640-1
C215, 216	**Mylar, .047 μ F, 10%, 250V	C50B638-5

RESISTORS		
Symbol	Description	Part No.
R201, 202	10K	R12DC103J
R203	Potentiometer, 250K, Balance	R50160-182BXA
R204, 205	18K	R12DC183J
R206, 207	56K	R12DC563J
R208, 209	220K	R12DC224J
R210, 211	Composition, 4.7K, 10%, 1/2W	RC20BF472K
R212, 213	150	R12DC151J
R214, 215	Potentiometer, 100K, Treble, Bass	R50160-183-1
R216, 217	Composition, 1M, 10%, 1/2W	RC20BF105K
R218, 219	680 Ω	R12DC684J
R220, 221	Composition, 4.7K, 10%, 1/2W	RC20BF472K
R222, 223	Composition, 1.8K, 10%, 1/2W	RC20BF182K

MISCELLANEOUS		
Symbol	Description	Part No.
Q201, 202	203, 204	
	Transistor, 2N2924	TR2N2924-18
---	Printed Circuit, High Filter	PC50B187-32
---	Printed Circuit, Tone Control	PC50B187-25

* Used on some boards.

** Used on -2 board.

BOARD VIEWED FROM COMPONENT SIDE

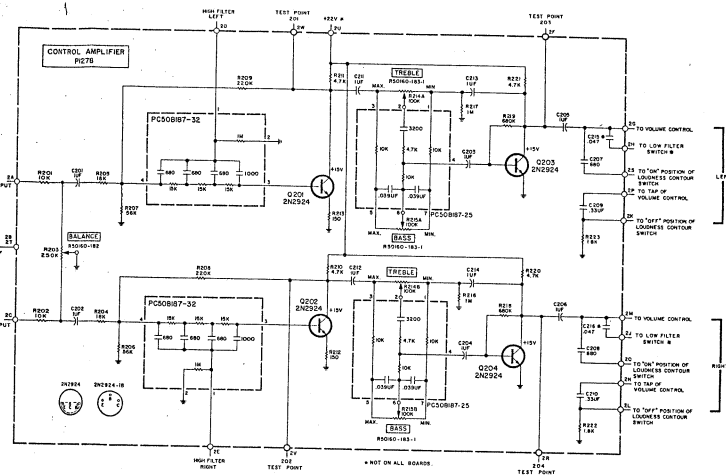
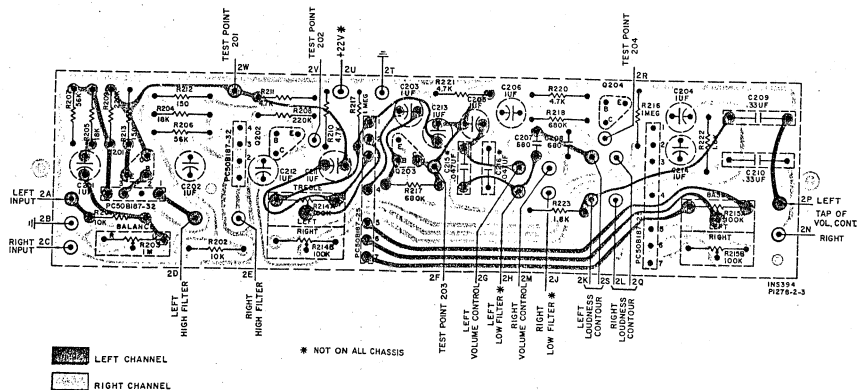

1389 PREAMPLIFIER

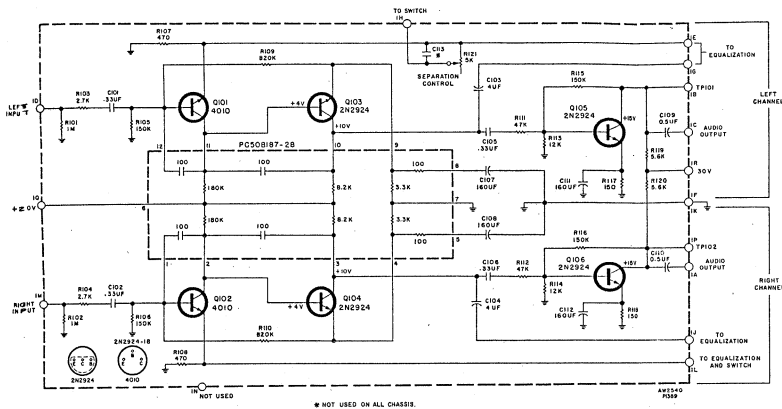

BOARD VIEWED FROM COMPONENT SIDE

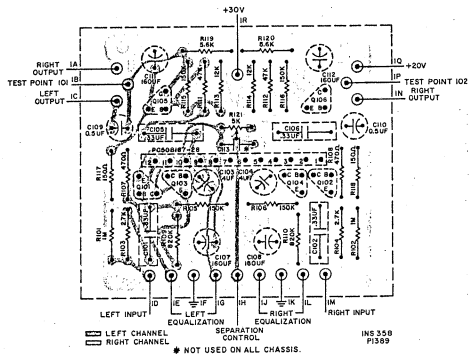

PARTS DESCRIPTION LIST

CAPACITORS

Symbol	Description	Part No.
C101, 102	Mylar, 0.33uF, 10%, 35V	C508638-10
C103, 104	Electrolytic, 4uF, 35V	C508637-1
C105, 106	Mylar, 0.33uF, 10%, 250V	C508638-10
C107, 108	Electrolytic, 100uF, 6V	C508637-3
C109, 110	Electrolytic, 0.5uF, 70V	C508637-5
C111, 112	Electrolytic, 100uF, 6V	C508637-3

RESISTORS

Deposited carbon in films, 5% tolerance, 1/8-watt, unless otherwise noted. K-Kilohms, M-Megohms.

Symbol	Description	Part No.
R101, 102	1M	R120C105J
R103, 104	2.7K	R120C292J
R105, 106	150K	R120C154J
R107, 108	470	R120C471J
R109, 110	820K	R120C824J
R111, 112	47K	R120C473J
R113, 114	12K	R120C123J
R115, 116	150K	R120C154J
R117, 118	150	R120C151J
R119, 120	5.6K	R120C562J
R121	Pat., SK, 305, Separation Control	R50150-62

MISCELLANEOUS

Symbol	Description	Part No.
Q101, 102	Transistor, 5E4010	TR4010-2
Q103, 104, 105, 106	Transistor, 2N2924	TR2N2924-18

1489-3 DRIVER

PARTS DESCRIPTION LIST

CAPACITORS		
Symbol	Description	Part No.
CS51, #52	Electrolytic, 25 μ F, 15V	CS5062J-6
CS52	Electrolytic, 200 μ F, 35V	CS0483-7

RESISTORS		
Symbol	Description	Part No.
Deposited carbon in ohms, 5% tolerance, 1/2 watt, unless otherwise noted, K=Kilohms, M=Megohms.		
R851	15K	R500C153J
R852	8.2K	R500C822J
R853	Composition, 3.9K	RC20BF392J
R854	56K	R500C563J
R855	220	R500C221J
R856	Composition, 82	RC20BF820J
R857	Par., 300, 20%, Center Voltage Adjust	RC20BF820J
R858	Par., 300, 20%, Output Bias Adjust	R500B499-1
R859	2.2K	R500C222J
R860	3.3K	R500C332J
R861	Composition, 82	RC20BF820J
R862	56K	R500C563J
R863	Composition, 120	RC20BF121J
R864	Composition, 82	RC20BF820J

MISCELLANEOUS		
Symbol	Description	Part No.
CR651	Diode, Silicon	S1D50894
CR852, 853	Diode, Zener, 4.8V, 5%, 1W	Z500921-2
CR854, 855	Diode, Silicon	S1D50894
Q851, #52	Transistor, TR1005	TR1005
Q852	Transistor, TR1004	TR1004

POWER AMPLIFIER CENTER VOLTAGE ADJUSTMENT

- Connect two 10K, $\pm 1\%$ resistors in series across capacitor C19 (200 μ F). Connect the common lead of a DC VTVM to the junction of the two resistors.
- Connect DC VTVM to the junction of resistors R37 and R39. Adjust Center Voltage Adjust Pot. R857 on left channel driver board for meter reading of 0 \pm 0.5 VDC.
- Connect DC VTVM to the junction of resistors R38 and R40. Adjust Center Voltage Adjust Pot. R857 on right channel driver board for meter reading of 0 \pm 0.5 VDC.
- Disconnect 10K resistors.

POWER AMPLIFIER IDLING CURRENT ADJUSTMENT

- NOTE: This adjustment is to be performed only after completing Center Voltage Adjustment.
- Connect DC VTVM across resistor R37. Adjust Output Bias Adjust Pot. R858 on left channel driver board for meter reading of 40 \pm 10mV DC.
 - Connect DC VTVM across resistor R38. Adjust Output Bias Adjust Pot. R858 on right channel driver board for meter reading of 40 \pm 10mV DC.

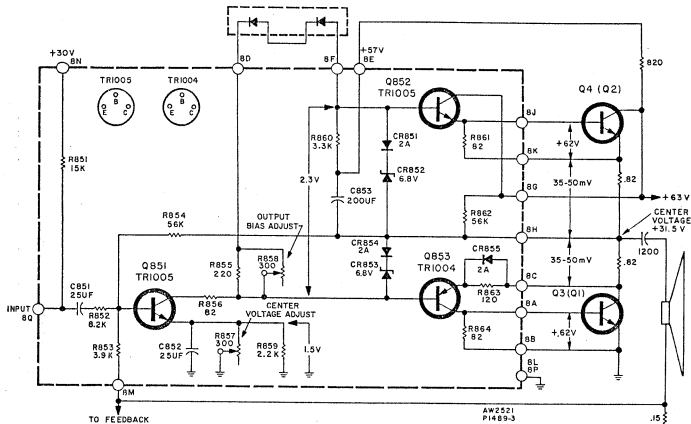

BOARD VIEWED FROM COMPONENT SIDE

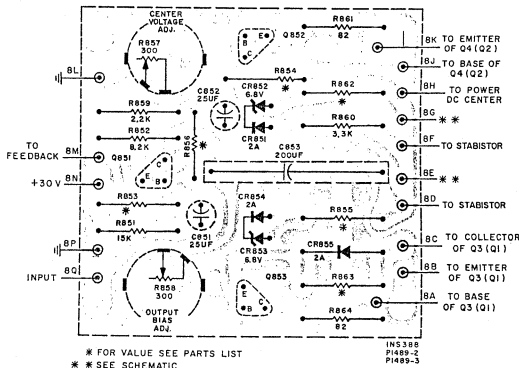

1478-3 PREDRIVER

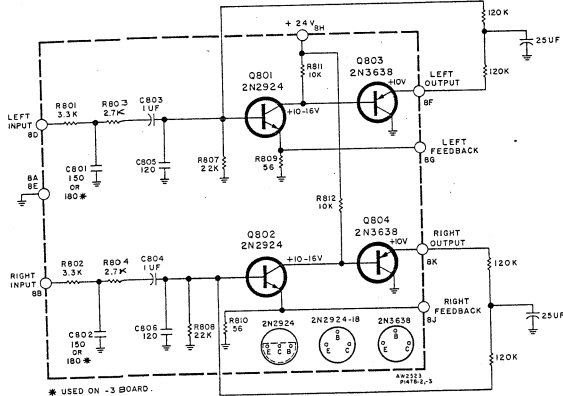

BOARD VIEWED FROM COMPONENT SIDE

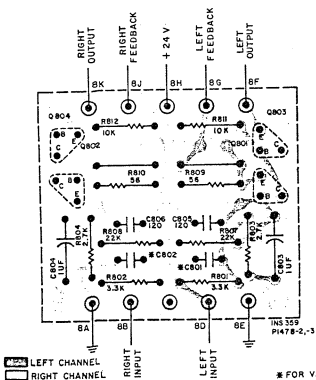

PARTS DESCRIPTION LIST

CAPACITORS

Symbol	Description	Part No.
CB01, 802	Ceramic, 150pF, 10%, 1000V	C50B569-9
CB03, 804	Ceramic, 180pF, 10%, 1000V	C50B569-14
CB05, 806	Tant. Electrolytic, 1uF, 20%, 25V	C50B640-1
CB05, 806	Ceramic, 120pF, 10%, 1000V	C50B569-16

RESISTORS

Deposited carbon in ohms, 5% tolerance, 1/8-watt, unless otherwise noted. K=Kiloohms, M=Megohms.

Symbol	Description	Part No.
RB01, 802	3.3K	R12DC332J
RB03, 804	2.7K	R12DC272J
RB05, 806	220K	R12DC224J
RB07, 808	22K	R12DC223J
RB09, 810	56	R12DC360J
RB11, 812	10K	R12DC103J

MISCELLANEOUS

Symbol	Description	Part No.
Q801, 802	Transistor, 2N2924	TR2N2924
Q803, 804	Transistor, 2N3638A	TR2N3638A-3

* Used on -1, -2 boards.
 ** Used on -3 board.
 † Used on -1 board.

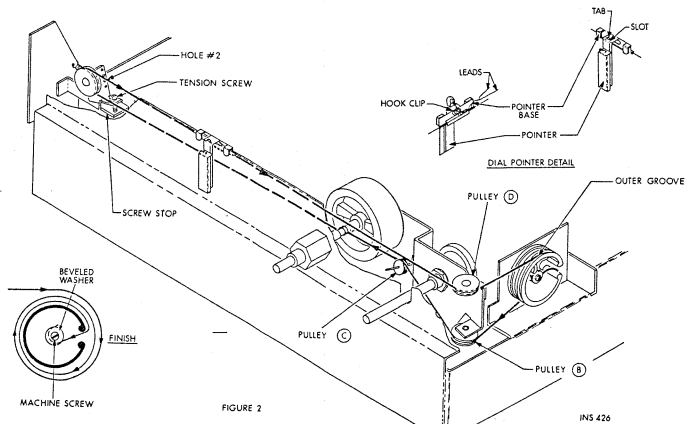
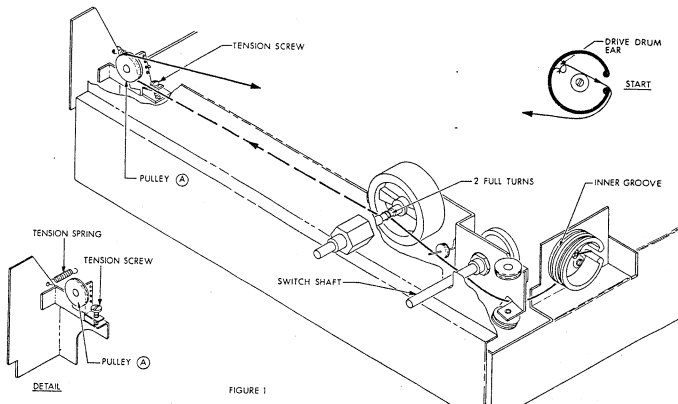

MAIN CHASSIS PARTS DESCRIPTION LIST

CAPACITORS			
Symbol	Description	Part No.	
C1, 2, 3	Ceramic, .02uF, ±80-20%, 100V	C50095-1	R50
C4	Electrolytic, 10uF, 35V	C50483-2	R51
C5, 6	Mylar, .22uF, 10%, 250V	C508575-2	R52
C7	Ceramic, 2700pF, 10%, 1000V	C50072-17	R53
C8	Ceramic, .02uF, ±80-20%, 100V	C50072-10	R54
C9, 10	Ceramic, 120pF, 10%, 1000V	C50072-40	R55
C11, 12	Electrolytic, 1200uF, 80V	C50180-90	R56
C13, 14	Mylar, .33uF, 10%, 250V	C508575-1	R57
C15	Ceramic, .02uF, ±80-20%, 100V	C50095-1	R58
C16	Molded, .01uF, 20%, 600V	C2747	R59
C17	Electrolytic, 200uF, 35V	C50483-7	R60
C18	Ceramic, 330pF, 10%, 1000V	C50072-1	R61
C19	Electrolytic, 2500uF, 80V	C50180-91	R62
C20	Electrolytic, 1000uF, 50V	C50180-80	R63
C21, 22	Electrolytic, 500uF, 35V	C50483-17	R64
C23	-Deleted-	---	R65
C24	Mylar, .015uF, 10%, 100V	C508574-2	R66
C25, 26,			R67
27, 28	Ceramic, 47pF, 5%, N750, 1000V	C50070-29	R68
C29	Ceramic, 330pF, 10%, 1000V	C50074-1	R69
C30	Electrolytic, 200uF, 15V	C50483-13	R70
C31	Electrolytic, 500uF, 35V	C50483-17	R71
C32	Ceramic, 680pF, 10%, 1000V	C50072-2	R72
C33, 34	Ceramic, 1000pF, 10%, 1000V	C50072-3	R73
C35	Electrolytic, 4uF, 35V	C50483-1	R74
C36	Electrolytic, 100uF, 25V	C50483-12	R75
C37, 38	Electrolytic, 75uF, 35V	C50483-12	R76

RESISTORS			
Deposited carbon on Ohms, 5% tolerance, 1/2 watt, unless otherwise noted. K=Kilohms, M=Megohms.			
Symbol	Description	Part No.	
R1	Composition, 270, 10%	RC20BF271K	PC1, 2
R2	82, 1/8W	R12DC82J	Q1, 2
R3	100, 1/8W	R12DC100J	3, 4
R4	1K, 1/8W	R12DC102J	Q5
R5	15K, 1/8W	R12DC153J	Q6, 7
R6	1K, 1/8W	R12DC102J	S1
R7, 8	27K, 1/8W	R12DC27J	
R9, 10	2.7K	R50DC27J	S2
R11	Composition, 220K, 10%	RC20BF224K	S3, 4, 5,
R12	-Deleted-	---	6
R13	Composition, 6.8K, 10%	RC20BF682K	S7
R14	Pat., 1K, 30%, Meter Adjust	RC20BF183K	S8
R15	Composition, 18K, 10%	R50150-53	T1
R16	Pat., 10K, 30%, Muting Adjust	RC20BF272K	
R17	Composition, 2.7K, 10%	RC30BF332K	---
R18	Composition, 3.3K, 10%, 1W	RC30BF332K	---
R19, 20,			---
21, 22	56K, 1/8W	R12DC56J	---
R23	100K, 1/8W	R12DC104J	---
R24A, B	Pat., Dual, 50K, Volume Control	R50160-151	---
R25, 26	470	R30DC47J	---
R27, 28	2.7K	R50DC27J	---
R29, 30	820	R50DC82J	---
R31, 32	33	R50DC33J	---
R33, 34	Wirewound, 330, 2W	RW200W331J	---
R35, 36	Power, 8, 10W	R50B895-1	---
R37, 38,			---
39, 40	Wirewound, 0.82, 5W	RL500WR82J	---
R41, 42	Wirewound, 39, 3W	RL300W390J	---
R43, 44	Wirewound, 0.15, 10%, 3W	RL300WR15K	---
R45	Composition, 820K, 10%	RC20BF824K	---
R46	Composition, 2.7K, 10%, 1W	RC30BF272K	---
R47	Wirewound, 270, 2W	RW200W271J	---
R48, 49	Wirewound, 150, 3W	RL300W151J	---

MISCELLANEOUS			
Symbol	Description	Part No.	
C, D	Rectifier, Silicon, 2A120	CR1A, B,	
CR2	Diode, Zener Regulator, 12V	C0483-13	SR50517
CR3	Diode, Zener Regulator, 24V	C0483-17	ZR50B793-1
CR4, 5	Stabistor Module, Dual Silicon	CR2	ZR50921-1
CR6	Diode, Silicon	CR3	SIT 50B863-3
CR7, 8	Diode, Germanium, IN2326	CR4, 5	SID50B851
F1	Fuse, Line, 3.2A Sta-Blo, 250V	CR6	GE750825-1
F2, 3	Fuse, Line, 1.5A Sta-Blo, 250V	CR7, 8	F3319
F4	Fuse, Speakers, 4A, 250V	F1	F3319-12
I1, 2	Lamp, Dial	F2, 3	F3319-4
I3	Lamp, Meter	I1, 2	150441-1
I4	Lamp, Stereo Beacon	I3	150005-8
I5	Lamp, Dial Pointer	I4	part of A550B814-1
M1	Meter, Tuning, 200uA	I5	part of A550B1-2
PC1, 2	Printed Circuit, Equalization	M1	M990-124
Q1, 2,	Transistor, TR1009	PC1, 2	PC50B187-29
Q3, 4	Transistor, 40245	Q1, 2,	
Q5	Transistor, 2N2924	Q3, 4	TR1009
Q6, 7	Transistor, 2N2924	Q5	TR40245-1
S1	Switch, Rotary, Selector	Q6, 7	TR2942924
S2	Switch, Rotary, Mode/Tape Monitor	S1	\$1276C116 or \$1276C146
S3, 4, 5,	Switch, Rocker, Loudness Control	S2	\$1276C147
6	Muting, Low Filter, High Filter	S3, 4, 5,	550C200-15-1
S7	Switch, Power	6	R50C200-15-1
S8	Switch, Rotary, Speakers	S7	part of S1276C117
S9	Switch, Slide, Center Channel	S8	S50200-2
T1	Transformer, Power	S9	T1276C115
---	Transformer, Power	T1	T276C153
---	Front End, FM	---	F50D965
---	Printed Circuit Board, Tone Control	---	P1276-2
---	Printed Circuit Board, IF Amplifier	---	P1381-1
---	Printed Circuit Board, Preamplifier	---	P1389
---	Printed Circuit Board, Predriver	---	P1478-3
---	Printed Circuit Board, Power Driver	---	P1487-9
---	Printed Circuit, MPX Decoder	---	P1531
---	Dress Panel Assembly	---	A51279C141
---	Dipole Assembly	---	A550237-1
---	Knob, Volume, Balance, Selector	---	E50B562-1
---	Knob, Dual, Top, Bass, Treble	---	E50B563
---	Knob, Dual, Bottom, Bass, Treble	---	E50B564
---	Knob, Speakers	---	E50B565-1
---	Knob, Tuning	---	E50B565-2
---	Tuning Capacitor Drive Drum	---	E50C588
---	Jack, Phones	---	J50B545
---	Dial Glass	---	N1276C108
---	*Used on export model.		

If replacement parts are out of stock, locally, they may be obtained directly from the Parts Department of FISHER Radio Corporation. They will be shipped "best way", either prepaid or C.O.D. unless otherwise specified.

For instrument-operation information and technical assistance write Richard Hamilton, Customer Service Department, FISHER Radio Corporation, Long Island City, New York 11101.