

Serial No. 20815^B



Stereophonic

THE FISHER 800-C

SERVICE MANUAL

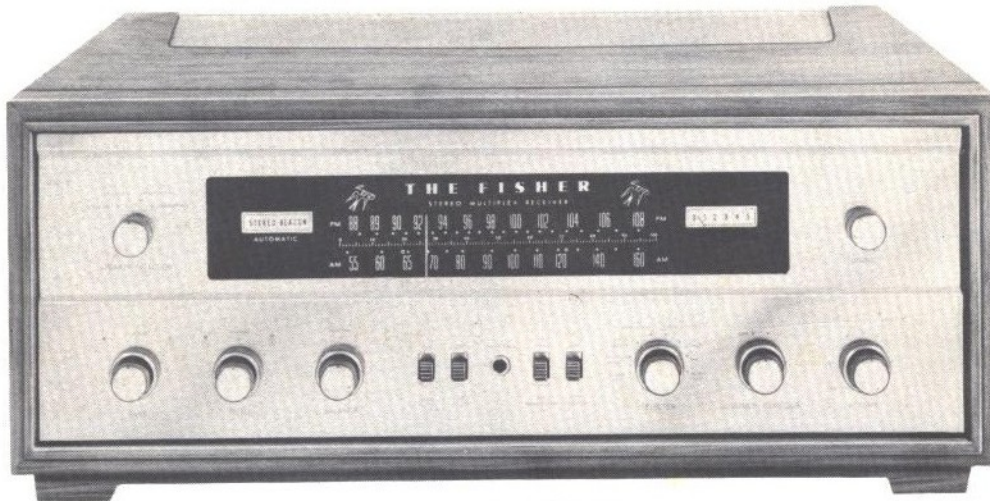

MODEL 800-C

CHASSIS SERIAL NUMBERS
FROM 20001 TO 29999 INCLUSIVE

PRICE: \$1.00

FISHER RADIO CORPORATION • NEW YORK

CHASSIS SERIAL NUMBERS
FROM 20001 TO 29999 INCLUSIVE

THE FISHER 800-C



PARTS DESCRIPTION LIST

CAPACITORS

10% tolerance for all fixed capacitors, unless otherwise noted or marked GMV (guaranteed minimum value). All capacitors not marked uf are Pf (puf).

Symbol	Description	Part No.
C1	Ceramic, 47, 5%, N750, 1000V	C50070-29
C2	Ceramic, 3, NPO, 1000V	C50070-28
C3	Ceramic, 1000, GMV, 500V	C50089-2
C4, 5, 6	Ceramic, Feedthru, 1000, GMV	C592-187
C7	Ceramic, 10, 5%, NPO, 1000V	C50070-39
C8	Ceramic, .02uf, +80 — 20%, 100V	C50073-1
C9	Ceramic, 1000, GMV, 500V	C50089-2
C10	Ceramic, 7, ±.5, NPO, 500V	CC20CJ070D5
C11	Ceramic Trimmer	C662-123
C12	Variable, FM-AM	C965-115
C13	Ceramic, .02uf, +80 — 20%, 500V	C50089-4
C14, 15	Ceramic, 18, N470, 1000V	C50070-13
C16	Mylar, .047uf, 400V	C50197-30
C17	Mylar, .047uf, 250V	C50197-52
C18	Mylar, .047uf, 400V	C50197-30
C19	Mylar, .047uf, 250V	C50197-52
C20	Ceramic, .68, 500V	C50077-6N
C21, 22	Ceramic, 220, 1000V	C50072-20
C23	Ceramic Trimmer	C662-123
C24	Ceramic, 8, ±.5, NPO, 500V	CC20CJ080D5
C25, 26	Ceramic, 7, NPO, 1000V	C50070-20
C27	Ceramic, 68, N750, 500V	CC20UJ680K5
C28	Ceramic, .02uf, +80 — 20%, 500V	C50089-4
C29	Ceramic, 100, 5%, N1500, 1000V	C50070-19
C30, 31	Ceramic, 100, N1500, 1000V	C50070-6
C32	Ceramic Trimmer	C662-123
C33	Ceramic, 24, 5%, N150, 1000V	C50070-8
C34	Ceramic, 8, ±.5, N330, 500V	CC20SJ080D5
C35	Ceramic, 1000, 1000V	C50072-3
C36	Ceramic, 68, N2200, 1000V	C50070-12
C37	Ceramic, 6, 5%, NPO, 1000V	C50070-43
C38	Ceramic, .02uf, +80 — 20%, 100V	C50073-1
C39	Ceramic, 68, N2200, 1000V	C50070-12
C40, 41	Ceramic, .02uf, 20%, 500V	C50089-5
C42, 43	Ceramic, Feedthru, 1000, GMV	C592-187
C44	Mylar, .047uf, 400V	C50197-30
C45	Ceramic, 820, 1000V	C50072-7
C46	Mylar, .047, 400V	C50435-25
C47	Ceramic, 820, 1000V	C50072-7
C48	Ceramic, .02, +80 — 20%, 100V	C50073-1
C49	Mylar, .047uf, 250V	C50197-52
C50	Ceramic, 100, N1500, 1000V	C50070-6
C51	Ceramic, 2700, 1000V	C50072-17
C52, 53	Ceramic, 5000, +80 — 20%, 500V	C50089-6
C54, 55	Ceramic, 100, 5%, N1500, 1000V	C50070-19
C56	Ceramic, 1, 20%, P100, 1000V	C50070-1
C57	Ceramic, .02uf, 20%, 500V	C50089-5
C58	Ceramic, 150, 1000V	C50072-18
C59	Ceramic, 5000, +80 — 20%, 500V	C50089-6
C60	Mylar, .1uf, 125V	C50435-7
C61	Ceramic, 2700, 1000V	C50072-17
C62	Ceramic, .02uf, GMV, 1000V	C50071-6
C63	Ceramic, 5000, +80 — 20%, 500V	C50089-6
C64	Mylar, .1uf, 125V	C50435-7
C65	Electrolytic, 2uf, 70V	C721-142
C66	Polystyrene, 1800, 5%, 125V	CP50394-11
C67	Electrolytic, .5uf, 350V	C50283-7
C68	Ceramic, .02uf, 20%, 500V	C50089-5
C69	Ceramic, 2200, 1000V	C50072-5
C70	Ceramic, .02uf, 20%, 500V	C50089-5
C71	Ceramic, 2200, 1000V	C50072-5
C72	Ceramic, 24, 5%, N150, 1000V	C50070-8
C73	Mylar, .1uf, 125V	C50435-7
C74	Ceramic, .02uf, +80 — 20%, 100V	C50073-1
C75, 76	Ceramic, 1000, 1000V	C50072-3
C77, 78	Ceramic, 120, N1500, 1000V	C50070-9
C79, 80	Ceramic, 24, 5%, N150, 1000V	C50070-8
C81	Ceramic, 2700, 1000V	C50072-17
C82, 83, 84, 85, 86	Ceramic, 5000, +80 — 20%, 500V	C50089-6
C87	Electrolytic, 4 Section: A — 20uf, 300V	C50180-49

B — 40uf, 400V
C — 40uf, 450V
D — 40uf, 500V

C88, 89, 90	Ceramic, 5000, +80 — 20%, 500V	C50089-6
C91	Electrolytic, 4 Section: A — 50uf, 250V B — 50uf, 250V C — 50uf, 250V D — 200uf, 250V	C50180-48
C92	Mylar, .1uf, 250V	C50197-54
C93, 94	Ceramic, 5000, +80 — 20%, 500V	C50089-6
C95	Electrolytic, 2 Section: A — 1000 uf, 35V B — 1000 uf, 35V	C50180-38
C96	Ceramic, 560, 1000V	C50072-14
C97	Ceramic, 2700, 1000V	C50072-17
C98	Electrolytic, 200uf, 250V	C50180-20
C99	Mylar, .022uf, 250V	C50197-49
C100	Ceramic, 5000, +80 — 20%, 500V	C50089-6
C101	Mylar, .022uf, 250V	C50197-49
C102	Ceramic, .02uf, GMV, 1000V	C50071-6
C103	Ceramic, Feedthru, 1000, GMV	C592-187
C104	Molded, .01uf, 20%, 600V	C2747
C105, 106	Ceramic, .01uf, 20%, 500V	C50089-3
C107, 108, 109	Ceramic, 330, 1000V	C50072-1
C110	Molded, .01uf, 20%, 600V	C2747
C111	Electrolytic, 8uf, 50V	C629-138
C112, 113	Ceramic, 100, GMV, N1500, 1000V	C50070-5
C114, 115	Ceramic, 330, 1000V	C50072-1
C116, 117	Electrolytic, 50uf, 10V	C50283-6

RESISTORS & POTENTIOMETERS

In ohms, 5% tolerance, 1/8 Watt, unless otherwise noted. K=Kilohms, M=Megohms.

Symbol	Description	Part No.
R1	Wirewound, 25, 10%, 5W	R688-117
R2	Composition, 270, 10%, 1/2 W	RC20BF271K
R3	Composition, 100K, 10%, 1/2 W	RC20BF104K
R4	Composition, 330, 10%, 1W	RC20BF331K
R5	Dep. Carbon, 2.2K, 1/2 W	R33DC222J
R6	Wirewound, 25, 10%, 5W	R688-117
R7	Dep. Carbon, 4.7K, 1/2 W	R33DC472J
R8	Composition, 330, 10%, 1W	RC30BF331K
R9	Dep. Carbon, 47	R12DC470J
R10	Dep. Carbon, 2.2K, 1/2 W	R33DC222J
R11	Composition, 3.3, 10%, 1/2 W	RC20BF3R3K
R12	Dep. Carbon, 100K	R12DC104J
R13	Dep. Carbon, 1M, 1/2 W	R33DC105J
R14	Composition, 100, 10%, 1/2 W	RC20BF101K
R15	Dep. Carbon, 1.8M, 1/2 W	R33DC185J
R16	Composition, 47K, 10%, 1/2 W	RC20BF473K
R17, 18, 19, 20	Dep. Carbon, 1K, 1/2 W	R33DC102J
R21, 22, 23, 24, 25	Dep. Carbon, 330K	R12DC334J
R26	Dep. Carbon, 180K, 1/2 W	R33DC184J
R27	Dep. Carbon, 3.9K, 1/2 W	R33DC392J
R28	Dep. Carbon, 180K, 1/2 W	R33DC184J
R29	Dep. Carbon, 3.9K, 1/2 W	R33DC392J
R30, 31	Dep. Carbon, 68K, 1/2 W	R33DC683J
R32	Dep. Carbon, 22K	R12DC223J
R33, 34	Dep. Carbon, 33K, 1/2 W	R33DC333J
R35	Dep. Carbon, 2.2K, 1/2 W	R33DC222J
R36	Dep. Carbon, 180, 1/2 W	R33DC184J
R37	Dep. Carbon, 2.2K, 1/2 W	R33DC222J
R38	Dep. Carbon, 180, 1/2 W	R33DC184J
R39, 40	Potentiometer, 25K, Phase Inverter Adj.	R50103-2
R41	Composition, 18K, 10%, 1W	RC30BF183K
R42, 43	Dep. Carbon, 470K, 1/2 W	R33DC474J
R44	Dep. Carbon, 470K	R12DC474J
R45, 46	Dep. Carbon, 47K	R12DC473J
R47	Potentiometer, 500K, Dual Volume	R50160-104
R48	Dep. Carbon, 27	R12DC270J
R49	Dep. Carbon, 2.7K	R12DC272J
R50, 51	Dep. Carbon, 270	R12DC271J

PARTS DESCRIPTION LIST

R52	Composition, 1K, 10%, 1/2 W	RC20BF102K	R145	Dep. Carbon, 10K	R12DC103J
R53	Composition, 2.7, 10%, 1/2 W	RC20BF272K	R146	Glass, 2.7K, 1/2 W	R20G272J
R54, 55	Dep. Carbon, 22K	R12DC223J	R147	Composition, 820K, 10%, 1/2 W	RC20BF824K
R56	Composition, 1K, 10%, 1/2 W	RC20BF102K	R148	Dep. Carbon, 100K	R12DC104J
R57	Potentiometer, 300K, Dual Balance	R50160-130	R149	Dep. Carbon, 10	R12DC100J
R58	Dep. Carbon, 56K	R12DC563J	R150	Dep. Carbon, 100K	R12DC104J
R59, 60	Dep. Carbon, 2.7M, 1/3 W	R33DC275J	R151	Dep. Carbon, 10	R12DC100J
R61, 62	Dep. Carbon, 120K, 1/3 W	R33DC124J	R152	Composition, 1.5K, 1/2 W	RC20BF152J
R63, 64	Dep. Carbon, 1K, 1/2 W	R33DC102J	R153	Composition, 1K, 1/2 W	RC20BF102J
R65	Composition, 180, 10%, 1/2 W	RC20BF181K	R154	Dep. Carbon, 15K, 1/3 W	R33DC153J
R66	Dep. Carbon, 3.3M, 1/3 W	R33DC335J	R155	Dep. Carbon, 150K	R12DC154J
R67	Dep. Carbon, 39K	R12DC393J	R156	Dep. Carbon, 68K	R12DC683J
R68	Dep. Carbon, 1K	R12DC102J	R157	Dep. Carbon, 150K	R12DC154J
R69	Composition, 27K, 10%, 1/2 W	RC20BF273K	R158	Dep. Carbon, 68K	R12DC683J
R70	Composition, 1K, 10%, 1/2 W	RC20BF102K	R159, 160	Dep. Carbon, 220K	R12DC224J
R71	Dep. Carbon, 39K	R12DC393J			
R72	Composition, 10K, 10%, 1/2 W	RC20BF103K			
R73	Composition, 100, 10%, 1/2 W	RC20BF101K			
R74, 75	Dep. Carbon, 220K	R12DC224J			
R76	Dep. Carbon, 82K	R12DC823J			
R77, 78	Dep. Carbon, 680K	R12DC684J			
R79, 80	Potentiometer, 500K, Dual Bass, Treble				
R81	Dep. Carbon, 680K	R50160-101-2			
R82	Dep. Carbon, 150K	R12DC684J			
R83	Dep. Carbon, 820K	R12DC154J			
R84	Composition, 150, 10%, 1/2 W	R12DC824J			
R85	Dep. Carbon, 470K	RC20BF151K			
R86	Dep. Carbon, 270K	R12DC474J			
R87	Composition, 47K, 10%, 1/2 W	R12DC274J			
R88	Dep. Carbon, 47K	RC20BF473K			
R89	Dep. Carbon, 820K	R12DC473J			
R90	Composition, 1K, 10%, 1/2 W	R12DC824J			
R91	Dep. Carbon, 820K	RC20BF102K			
R92	Dep. Carbon, 56K	R12DC824J			
R93, 94	Dep. Carbon, 820K	R12DC563J			
R95	Dep. Carbon, 68K	R12DC824J			
R96	Dep. Carbon, 120K, 1/3 W	R12DC683J			
R97	Dep. Carbon, 1K, 1/3 W	R33DC124J			
R98	Dep. Carbon, 120K, 1/3 W	R33DC102J			
R99	Dep. Carbon, 1K, 1/3 W	R33DC124J			
R100	Dep. Carbon, 2.2M, 1/3 W	R33DC102J			
R101	Composition, 220, 10%, 1/2 W	R33DC225J			
R102	Dep. Carbon, 2.7M, 1/3 W	RC20BF221K			
R103	Dep. Carbon, 1.5M, 1/3 W	R33DC275J			
R104	Dep. Carbon, 2.7M, 1/3 W	R33DC155J			
R105	Dep. Carbon, 1.5M, 1/3 W	R33DC155J			
R106	Composition, 220, 10%, 1/2 W	RC20BF221K			
R107, 108	Dep. Carbon, 470K	R12DC474J			
R109, 110	Dep. Carbon, 330K	R12DC334J			
R111	Dep. Carbon, 22K	R12DC223J			
R112	Composition, 100, 10%, 1/2 W	RC20BF101K			
R113	Composition, 82K, 10%, 1/2 W	RC20BF823K			
R114	Composition, 1K, 10%, 1/2 W	RC20BF102K			
R115	Composition, 82K, 10%, 1/2 W	RC20BF823K			
R116	Dep. Carbon, 47K	R12DC473J			
R117	Composition, 22K, 10%, 1/2 W	RC20BF223K			
R118	Dep. Carbon, 180	R12DC180J			
R119	Dep. Carbon, 5.6K, 1/3 W	R33DC562J			
R120	Composition, 2.7K, 10%, 1W	RC30BF272K			
R121	Glass, 470, 10%, 3W	RPG3W471K			
R122	Dep. Carbon, 10K, 1/3 W	R33DC103J			
R123	Composition, 1.2K, 10%, 1W	RC30BF122K			
R125, 126	Dep. Carbon, 82K	R12DC823J			
R127	Wirewound, 15, 10%, 5W	R719-106			
R128	Glass, 1.2K, 10%, 7W	RPG7W122K			
R129	Glass, 470, 10%, 3W	RPG3W471K			
R130	Dep. Carbon, 330K	R12DC334J			
R131	Composition, 68K, 10%, 1/3 W	RC20BF683K			
R132	Dep. Carbon, 330K	R12DC334J			
R135, 136	Dep. Carbon, 4.7M, 1/3 W	R33DC475J			
R137	Composition, 1K, 10%, 1/2 W	RC20BF102K			
R138	Composition, 270, 1/2 W	RC20BF271J			
R139, 140	Dep. Carbon, 220K, 1/3 W	R33DC224J			
R141, 142	Glass, 330K, 1W	R30G334J			
R143	Dep. Carbon, 10K	R12DC103J			
R144	Glass, 2.7K, 1/2 W	R20G272J			

COILS, CHOKES & TRANSFORMERS

Symbol	Description	Part No.
L1	FM Antenna Coil	L965-119
L2	AM Ferrite Loop	L990-132
L3	Choke, Ferrite Bead	L592-189
L4	Choke, 1.5 Microhenry	L50066-4
L5	AM-RF Transformer	L50210-35
L6	FM-RF Coil	L965-116
L7	FM Mixer Coil	L965-117
L8	Choke, 1 Microhenry	L50066-2
L9	AM Oscillator Coil	L50210-28
L10	Choke, 1 Microhenry	L50066-2
L11	FM Oscillator Coil Assembly	AS985-120
L12, 13,		
14	Choke, 1 Microhenry	L50066-2
L16 thru 27	Choke, Filament, Ferrite Bead	L592-189
L28	Choke, 3.3 Microhenries	L50066-8
T1	Transformer, Power	T991-115
T2	Transformer, Output	T991-116-1
T3	Transformer, Output	T991-116-2
Z1	Transformer, AM, IF	ZZ50210-41
Z2	Transformer, FM, IF	ZZ50210-42
Z3	Transformer, FM, IF	ZZ50210-39
Z4	Transformer, AM, IF	ZZ2984
Z5	Transformer, FM, IF	ZZ50210-2
Z6	FM Limiter Coil	ZZ50210-6
Z7	FM Ratio Detector	ZZ50210-9

MISCELLANEOUS

Symbol	Description	Part No.
CR1, 2, 3,		
4, 5	Diode, Type 1112	V1112
CR6, 7	Diode, Silicon	SR50411-1
F1	Fuse, 3.2 Amp Slo-Blo	F3319
I1	Lamp, #47 OF	I50009-4
I2, 3	Lamp, Dial	I50082-8
I4	Lamp, #47 OF, Stereo Beacon	I50009-4
J1	Headphone Jack	J846-120-1
M1	Meter, Tuning	M990-124
PC1	Printed Circuit	PC50434
PC2, 3	Printed Circuit, High Filter	PC50187-2
PC4, 5	Printed Circuit, Tone Control	PC50187-9
PC6, 7	Printed Circuit, Equalization	PC50187-3
RL1	Relay	K50314
S1	Switch, Selector	S990-131BX
S2	Switch, Slide, AM Bandwidth	S50200-5
S3	Switch, Speaker Selector	S990-130
S4	Switch, Loudness Contour	S990-129
S5, 6, 7	Switch, Slide	S50200-5
S8	Switch, Power	part of R47
SR1	Selenium Rectifier, Bridge	SR50253-1
—	FM Dipole Assembly	AS50227-1
—	Dress Panel	AS990-108
—	Knob, Dummy Dual	E50324
—	Knob, Dual, Rear	E50221
—	Knob, Dual, Front	E50323
—	Knob, Tuning	E50325-2
—	Knob, Speaker Selector	E50325-2
—	Dial Glass	N990-107
—	Fuse Holder	X563-551

ALIGNMENT INSTRUCTIONS

Read These Instructions With Extreme Care Before Attempting Alignment.

CHASSIS: Turn the station selector completely counterclockwise, without forcing. Dial pointer should be at zero index mark on logging scale. If not, reset the dial pointer. Disconnect the external antennas and the antenna link. Set Ferrite Loop to normal position, parallel to rear panel. When using an oscilloscope for alignment, set the output level controls for no overload, as shown by the proper waveform shape. Connect leads to main output and turn volume control to minimum.

SIGNAL GENERATORS: The signal generator equipment must be able to supply the following: FM RF modulated 30% (± 22.5 KC deviation) at 400 cps; AM RF modulated 30% at 400 cps;

AM IF with 30KC sweep for AM bandwidth adjustment.

INDICATOR: DC VTVM, AC VTVM, and scope for alignment.

ALIGNMENT: Allow the chassis and test instruments to warm up for at least fifteen minutes. Adjust the line voltage for 117 volts AC, 50-60 cycles. Use fully insulated tools: a small screw-driver for all trimming capacitors; a K-Tran tool for Z1, Z2, Z3, Z4, Z5; a hex tool for L1, L5, L6, L7, L9, L11, Z6 and Z7. For AM alignment, short AVC lead to ground.

NOTE: For calibrating both the AM and FM, use as low an output voltage as possible from your signal generator.

STEPS	CHASSIS			SIGNAL GENERATOR				INDICATOR		ALIGNMENT	
	AM BANDWIDTH	SELECTOR	STATION SELECTOR	COUPLING	FREQ.	MOD.	TYPE	CONNECTION	ADJUST	INDICATION	
1	SHARP	AM	Point of no signal and no interference	AM Gen. connected thru .01-uf cap. in series with hot lead to V8, Pin 7	455 KC	30% AM at 400 cps	AC VTVM to Left Rec. Output	Z1, Z4 top and bottom	Maximum voltage		
2	BROAD	AM	Point of no signal and no interference	AM Gen. connected thru .01-uf cap. in series with hot lead to V8, Pin 7	455 KC	30 KC sweep	Scope to Left Rec. Output	Z4 bottom	Adjust slightly for symmetrical curve		
3	SHARP	AM	600 KC	AM Gen. connected thru 220-uf to the AM antenna terminal. Disconnect link between terminals.	600 KC	30% AM at 400 cps	AC VTVM to Left Rec. Output	L9, L5, L2	Maximum voltage		
4	SHARP	AM	1400 KC	AM Gen. connected thru 220-uf to the AM antenna terminal. Disconnect link between terminals.	1400 KC	30% AM at 400 cps	AC VTVM to Left Rec. Output	C12J, C12G, C12E	Maximum voltage		
5	Repeat steps 3 and 4 for proper dial calibration and maximum output.										
6		FM	Point of no signal and no interference	FM Gen. connected to ungrounded tube shield of V2	10.7 MC	None	DC VTVM to test point 3	Z2, Z3, Z5, Z6 Z7, top and bottom	Maximum negative voltage		
7		FM	Point of no signal and no interference	FM Gen. connected to ungrounded tube shield of V2	10.7 MC	None	Connect hot lead of DC VTVM to TSP4, ground to junction of resistors (R7N) connected in series from TSP3 to GND.	Z7, top	Zero reading on zero center scale		
8		FM	90 MC	FM Gen. connected thru two 120-ohm carbon resistors in series with lead to antenna terminals Normal.	90 MC	30% FM (22.5 KC Dev.) at 400 cps	DC VTVM to TSP3 and scope to Left Rec. output	L11, L7, L6, L1	Check for sine waveform and adjust for maximum negative voltage		
9		FM	106 MC	FM Gen. connected thru two 120-ohm carbon resistors in series with lead to antenna terminals Normal.	106 MC	30% FM (22.5 KC Dev.) at 400 cps	DC VTVM to TSP3 and scope to Left Rec. output	C32, C23, C11	Check for sine waveform and adjust for maximum negative voltage		
10	Repeat steps 8 and 9 for proper dial calibration and maximum output.										

AM ALIGNMENT

FM ALIGNMENT

SCHEMATIC DIAGRAM

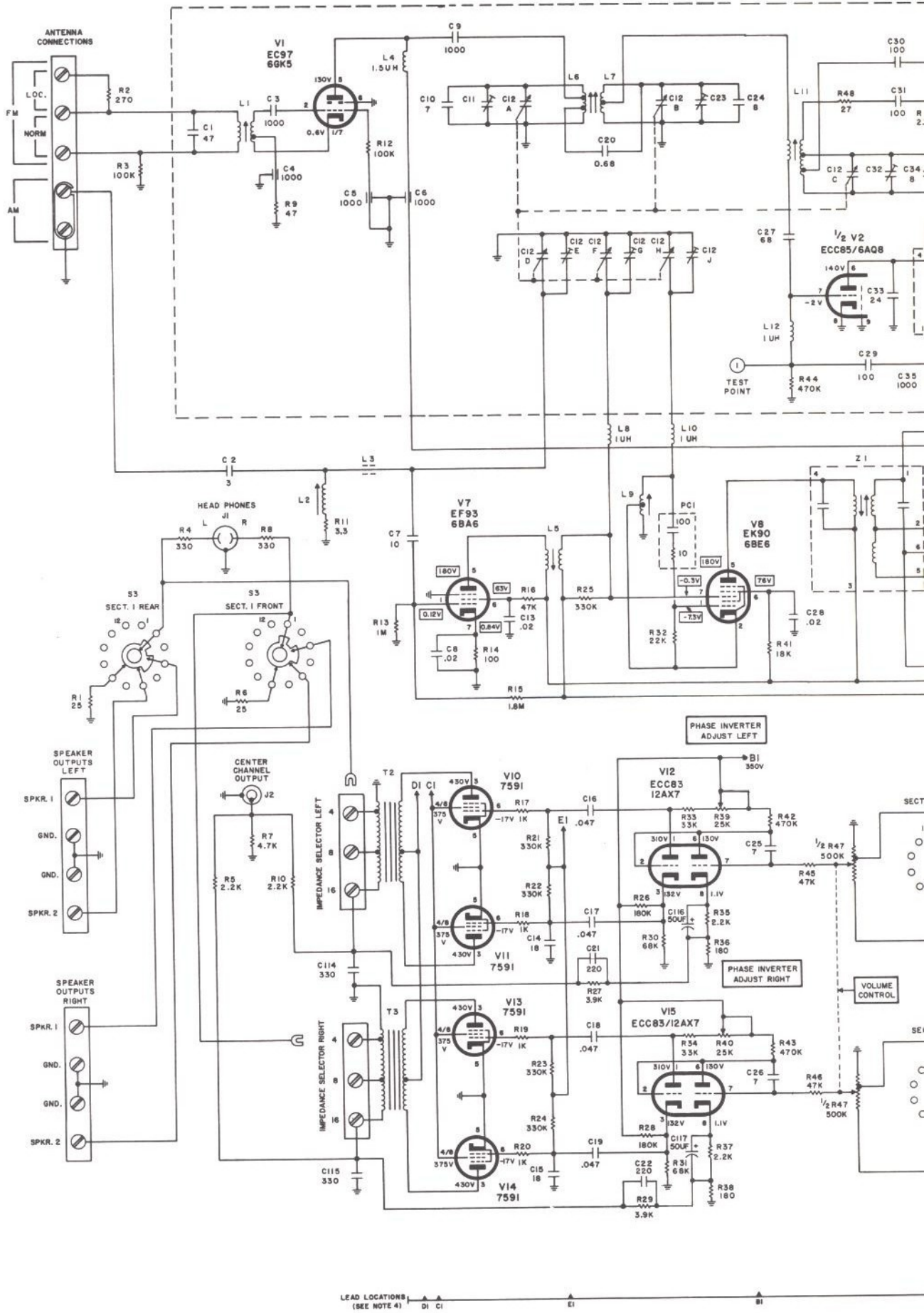

LEAD LOCATIONS (SEE NOTE 4) DI CI EI BI

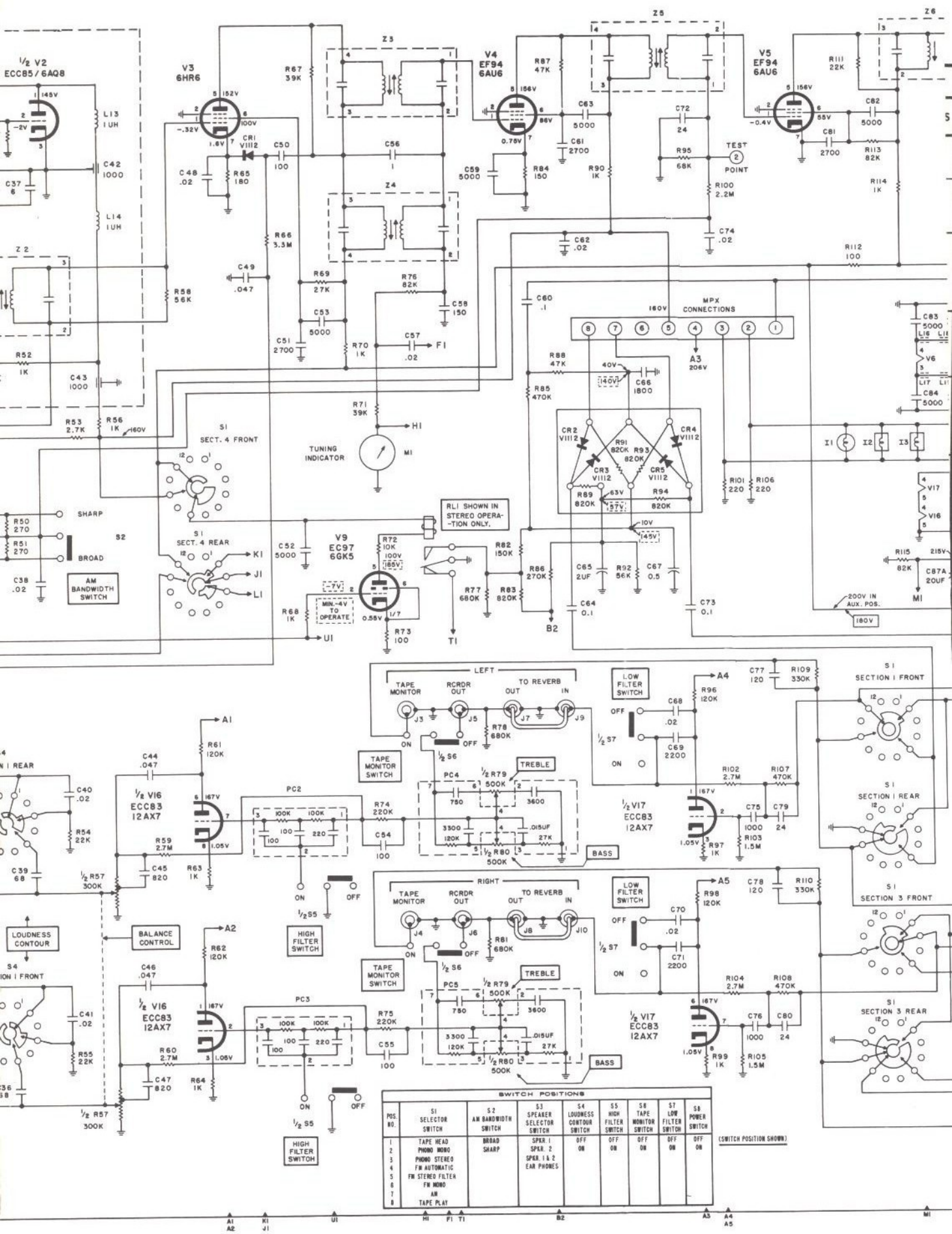

SWITCH POSITIONS

POS. NO.	S1 SELECTOR SWITCH	S2 AM BANDWIDTH SWITCH	S3 SPEAKER SELECTOR SWITCH	S4 LOUDNESS CONTOUR SWITCH	S5 HIGH FILTER SWITCH	S6 TAPE MONITOR SWITCH	S7 LOW FILTER SWITCH	S8 POWER SWITCH
1	TAPE HEAD	BROAD	SPEER. 1	OFF	OFF	OFF	OFF	OFF
2	FM/NO. HRO.	SHARP	SPEER. 2	ON	ON	ON	ON	ON
3	FM/NO. STEREO							
4	FM AUTOMATIC							
5	FM STEREO FILTER							
6	FM HRO.							
7	AM							
8	TAPE PLAY							

(SWITCH POSITION SHOWN)

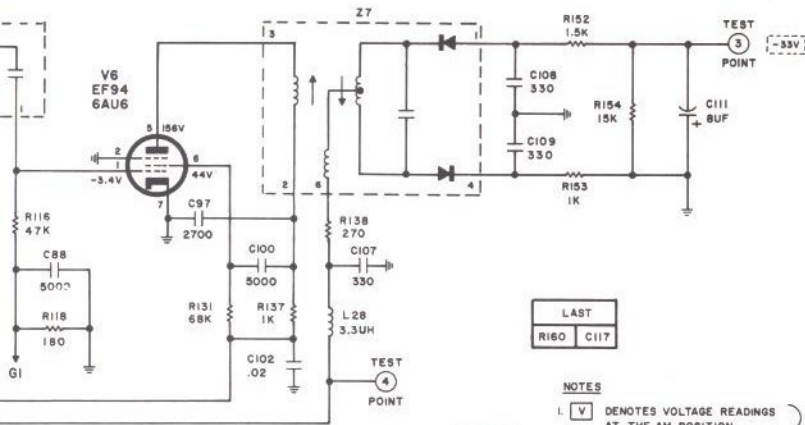

LAST
R160 C117

NOTES

1. \square V DENOTES VOLTAGE READINGS AT THE AM POSITION. NO SIGNAL AT THE ANTENNA TERMINALS
2. V DENOTES VOLTAGE READINGS AT THE FM POSITION.
3. \square V DENOTES VOLTAGE READINGS AT THE MPX STEREO POSITION WITH STEREO SIGNAL RECEIVED.
4. ALL LEADS WITH THE SAME LETTER DESIGNATION ARE CONNECTED TOGETHER.
EXAMPLE:
LEADS A1 THRU A5 WOULD BE CONNECTED TO LEAD A6.

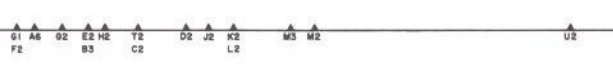
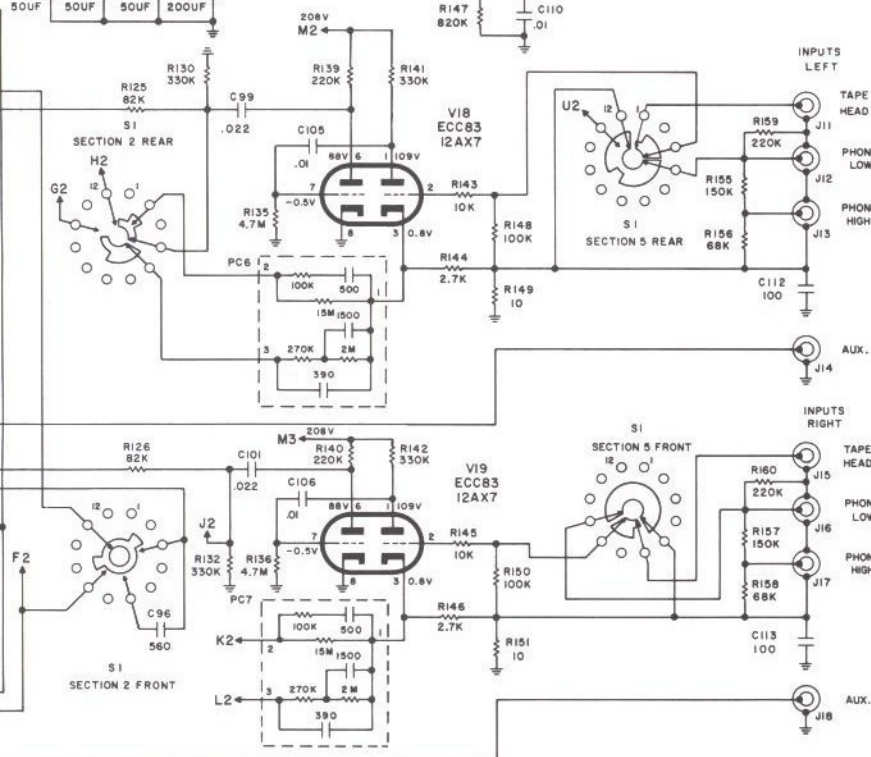
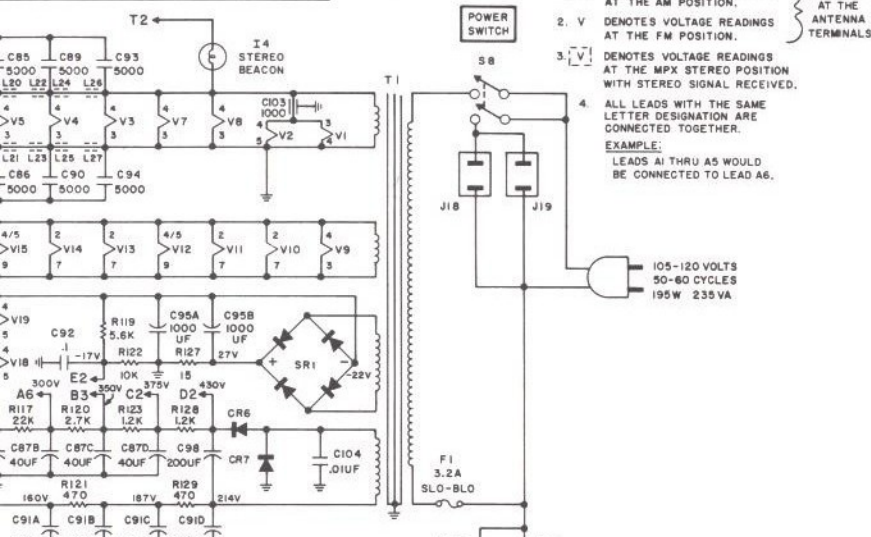

AW 2101B P990 SCHEMATIC

PARTS DESCRIPTION

CAPACITORS

10% tolerance for all fixed capacitors, unless otherwise noted or marked GMV (guaranteed minimum value). All capacitors not marked uf are pF (uuf).

Symbol	Description	Part No.
C200	Ceramic, .01uf, +80 — 20%, 500V	C50089-7
C201	Ceramic, 680, 1000V	C50072-2
C203	Ceramic, 220, 1000V	C50183-3
C204	Polystyrene, 470, 5%, 500V	C50394-1
C205	Ceramic, 82, 1000V	C50070-1
C206	Ceramic, 1000, GMV, 500V	C50089-2
C207	Ceramic, 5000, +80 — 20%, 500V	C50089-6
C208, 209	Mica, 4700, 5%, 500V	C50332-5
C210	Electrolytic, 1uf, 350V	C50283-3
C211	Ceramic, 1000, GMV, 500V	C50089-2

C212	Ceramic, .05uf, +80 — 20%, 100V	C500:
C214	Mylar, 4700, 400V	C50197:
C215	Mica, 3900, 5%, 500V	C503:
C216, 217	Ceramic, 1000, GMV, 500V	C500:
C218	Ceramic, .02uf, 20%, 500V	C500:
C219	Ceramic, 330, 1000V	C501:
C220	Ceramic, .02uf, 20%, 500V	C500:
C221, 222	Mylar, .047uf, 250V	C5019:
C223, 224	Ceramic, 1000, 1000V	C500:
C225, 226	Ceramic, 2200, 1000V	C500:

RESISTORS

In ohms, 5% tolerance, 1/8 W unless otherwise noted. K=Kilohms, M=Megohms.

Symbol	Description	Part
R200	Composition, 22M, 10%, 1/2 W	RC20BF2

SCHEMATIC DIAGRAM

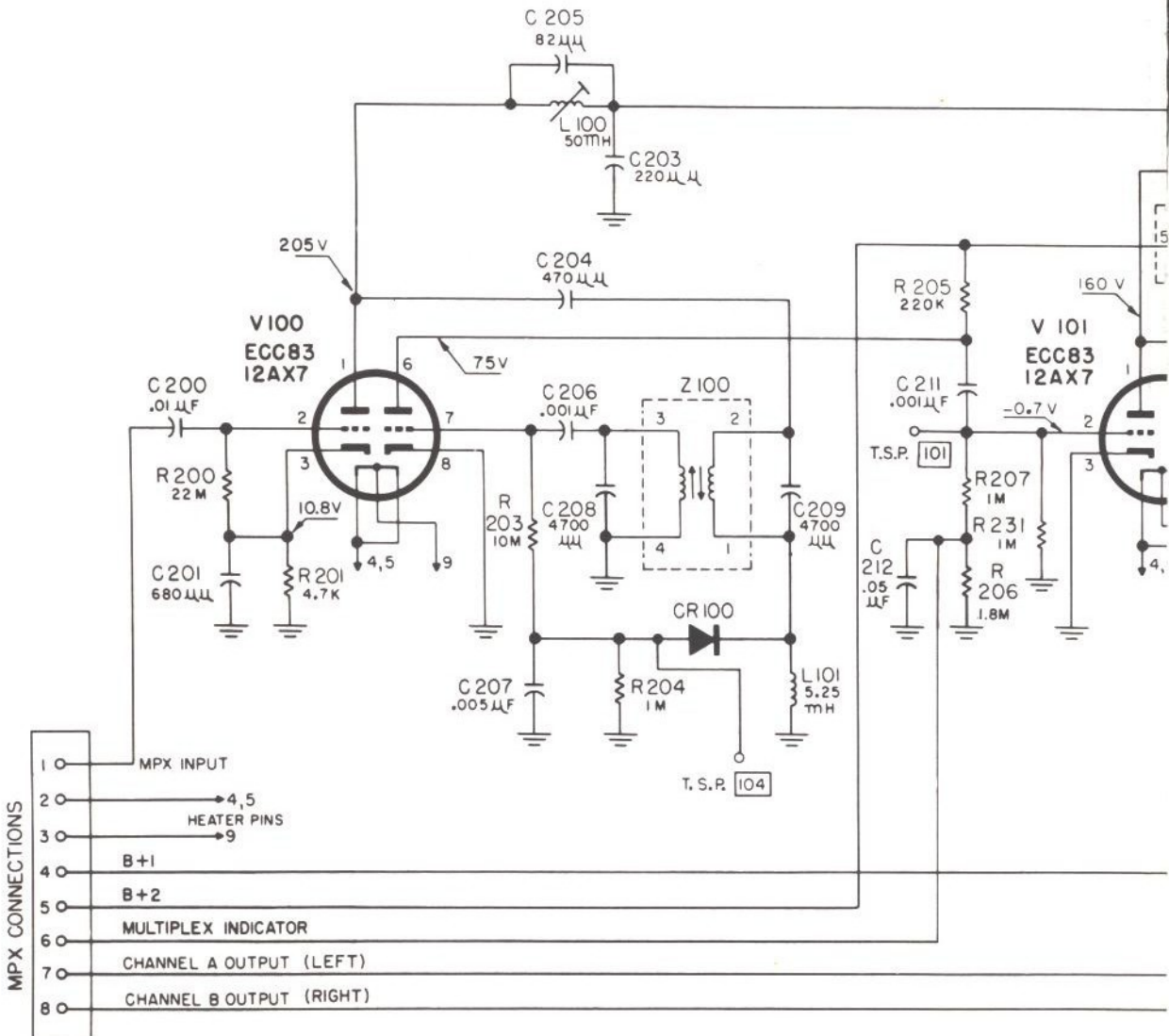

ON LIST • MULTIPLEX SECTION

3-2	R201	Composition, 4.7K, 1/2 W
-25	R202	Composition, 15K, 1/2 W
2-6	R203	Composition, 10M, 10%, 1/2 W
9-2	R204	Dep. Carbon, 1M
9-5	R205	Dep. Carbon, 220K, 1/3 W
3-5	R206	Dep. Carbon, 1.8M
9-5	R207	Dep. Carbon, 1M
-52	R208	Dep. Carbon, 22K
2-3	R209, 210,	
2-5	211, 212	Dep. Carbon, 33K
	R213, 214	Dep. Carbon, 100K
	R215	Potentiometer, 50K, MPX Separation
	R216	Composition, 22M, 10%, 1/2 W
	R217, 218	Dep. Carbon, 18K, 1/3 W
No.	R219, 220	Dep. Carbon, 15K, 1/3 W
26K	R221	Composition, 22M, 10%, 1/2 W

RC20BF472J
RC20BF153J
RC20BF106K
R12DC105J
R33DC224J
R12DC185J
R12DC105J
R12DC223J
R12DC333J
R12DC104J
R50150-4
RC20BF226K
R33DC183J
R33DC153J
RC20BF226K

R222, 223	Dep. Carbon, 27K
R224, 225	Dep. Carbon, 22K
R226, 227,	
228, 229,	
230, 231	Dep. Carbon, 1M

R12DC273J
R12DC223J
R12DC105J

MISCELLANEOUS

Symbol	Description	Part No.
CR100, 102,		
103	Diodes, Type 1112	V-1112
L100	Coil, low pass	L50210-30
L101	Coil, 5.25MH	L50334-1
L102, 103	Coil, 20MH	L50334-2
Z100	Transformer, 19Kc	ZZ50210-34
Z101	Coil, 38Kc	ZZ50210-33

GRAM • MULTIPLEX SECTION

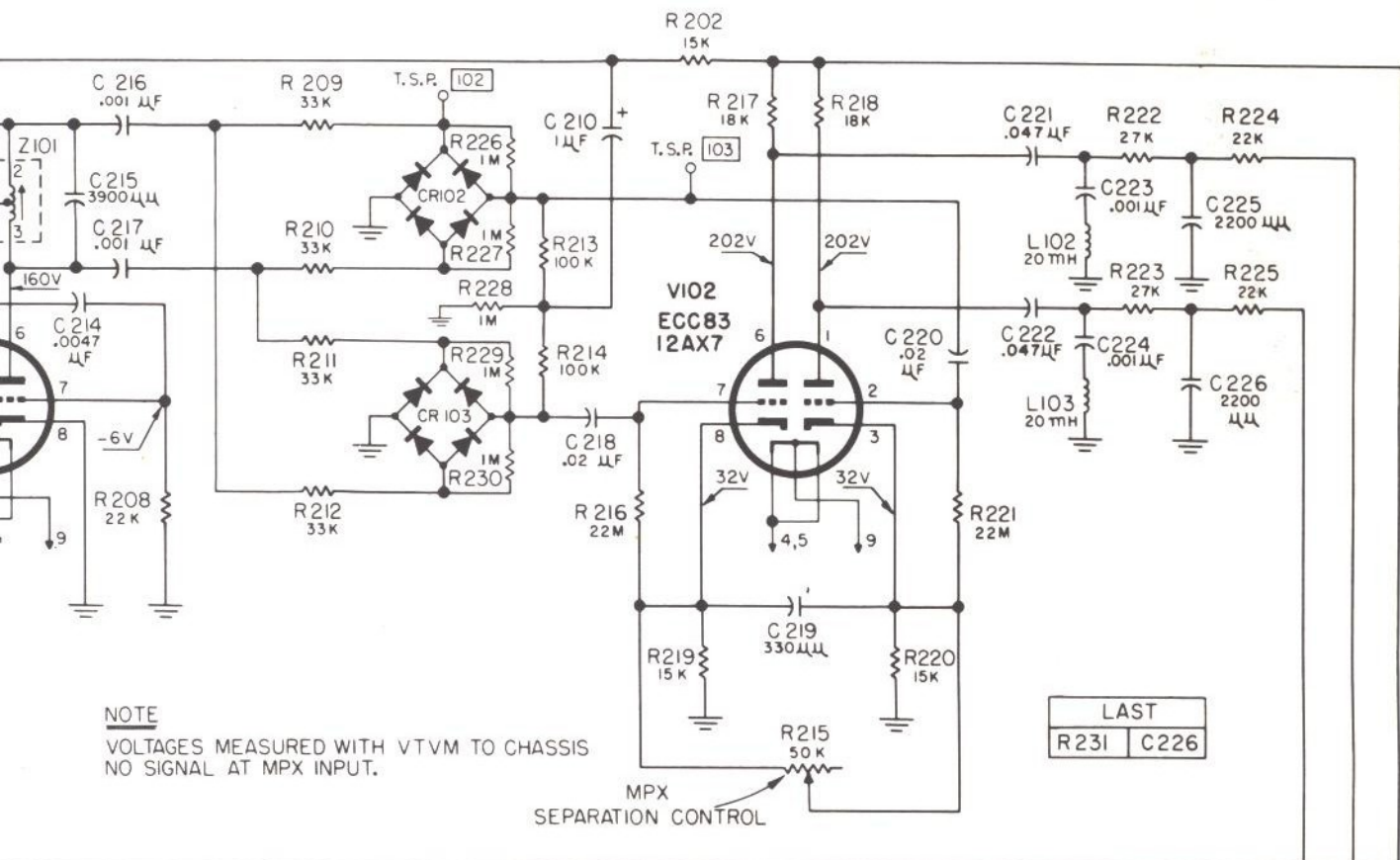

ALIGNMENT INSTRUCTIONS • MULTIPLEX SECTION

STEPS	GENERATOR			INDICATOR	ALIGNMENT		
	CONNECTION	AUDIO FREQUENCY	RF MODULATION	TYPE & CONNECTION	ADJUST	INDICATION	NOTES
1	Audio oscillator connected to lug 1	80 KC—1 volt	None	AC VTVM to junction of C210 and R228	L100 (Use hex alignment tool)	Minimum voltage	
2	Multiplex generator audio output to lug 1 (See Note 1)	19 KC (± 5 cps) pilot tone, 100 mv	None	DC VTVM to T.S.P. 101	Z100 top and bottom (Use hex alignment tool)	Maximum voltage	1
3	Same as Step 2	19 KC pilot tone, 50 mv	None	Scope horiz. input to 19 KC output of gen.; vert. input to junction of C216 and R209. External sweep	Z101 (Use K-tran alignment tool)	Stable 2:1 Lissajous pattern. Disregard phase of pattern	1
4	Same as Step 2	19 KC	None	Same as Step 3	Vary generator 19 KC output from 50 to 200 mv	Lissajous pattern should remain stationary over the entire 150 mv range	1, 2
5	Same as Step 2	1000 cps on left (A) channel only, 1 volt rms (2.8 P-P)	None	AC VTVM and scope vert. input to channel A output lug. Internal sweep. DC VTVM to T.S.P. 101	Z100 top (Use hex tool)	Maximum indication on AC VTVM. Clean 1000 cps waveform on scope	1, 3
6	Same as Step 2	1000 cps on right (B) channel only, 1 volt rms (2.8 P-P)	None	Same as Step 5	MPX separation R215	Minimum reading on AC VTVM should be at least 33 db below reading obtained in Step 5	1
7	Same as Step 2	Same as Step 6	None	Move scope input and AC VTVM to channel B output lug	-----	Note and record voltage reading on AC VTVM	1
8	Same as Step 2	1000 cps on left (A) channel only, 1 volt rms (2.8 P-P)	None	Same as Step 7	-----	AC VTVM reading should be at least 33 db below reading observed in Step 7	1
9	Same as Step 2	8000 cps on right (B) channel only, 1 volt rms (2.8 P-P)	None	Same as Step 7	-----	AC VTVM reading should be the same as observed in Step 7	1
10	Same as Step 2	8000 cps on left (A) channel only, 1 volt rms (2.8 P-P)	None	Same as Step 7	-----	AC VTVM reading should be at least 18 db below reading observed in Step 9	1
11	Repeat Steps 9 and 10 with scope and AC VTVM connected to channel A output lug, but start with 8000 cps applied to left channel for first reading, then switch to right channel for second reading.						
12	Multiplex generator RF output to 300-ohm antenna terminals	1000 cps on left (A) channel only	100% (75 KC Dev.) No pre-emphasis	Move scope input and AC VTVM to channel A output lug	-----	Note and record voltage reading on AC VTVM	4
13	Same as Step 12	1000 cps on right (B) channel only	Same as Step 12	Same as Step 12	R215	Minimum reading on AC VTVM should be at least 33 db below reading observed in Step 12	4
14	Same as Step 12	8000 cps on left (A) channel only	Same as Step 12	Same as Step 12	-----	AC VTVM reading should be 10 db below reading observed in Step 12	4
15	Same as Step 12	8000 cps on right (B) channel only	Same as Step 12	Same as Step 12	-----	AC VTVM reading should be 28 db below reading observed in Step 12	4

NOTE: The above procedure is based on the use of the FISHER Model 300 Multiplex Generator.

1 — In steps 2 through 11, the audio output of the Multiplex Generator should be connected to lug 1 of the multiplex sub-chassis through a 12,000 ohm, 1/2-watt, carbon resistor, and a 180 uuf capacitor should be connected between lug 1 and ground. The wiring from the MPX TEST jack on the main chassis to lug 1 must be disconnected during Steps 2 through 11.

2 — The vertical amplitude of the Lissajous pattern will increase slightly

as the generator output is increased. This is a normal occurrence.

3 — If DC VTVM reading falls below —9 volts when maximum reading is obtained on the AC VTVM, readjust bottom of Z100, then repeat Step 5. Repeat this procedure until maximum AC VTVM reading is obtained with DC VTVM reading greater than —9 volts.

4 — Tune the FISHER to the RF output frequency of the Multiplex Generator.

TUBE LAYOUT

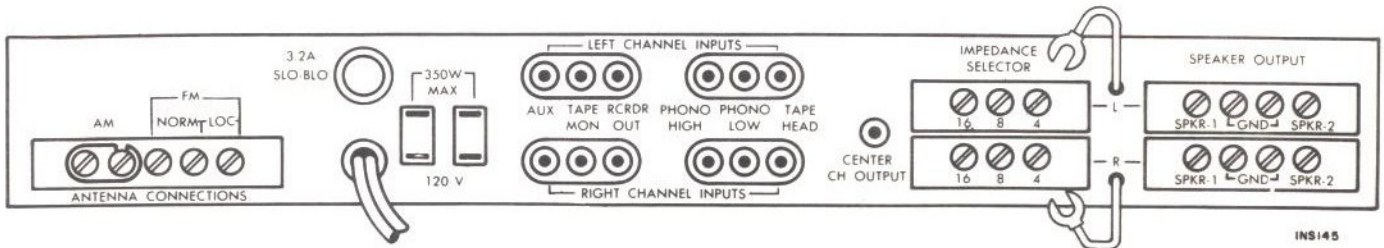
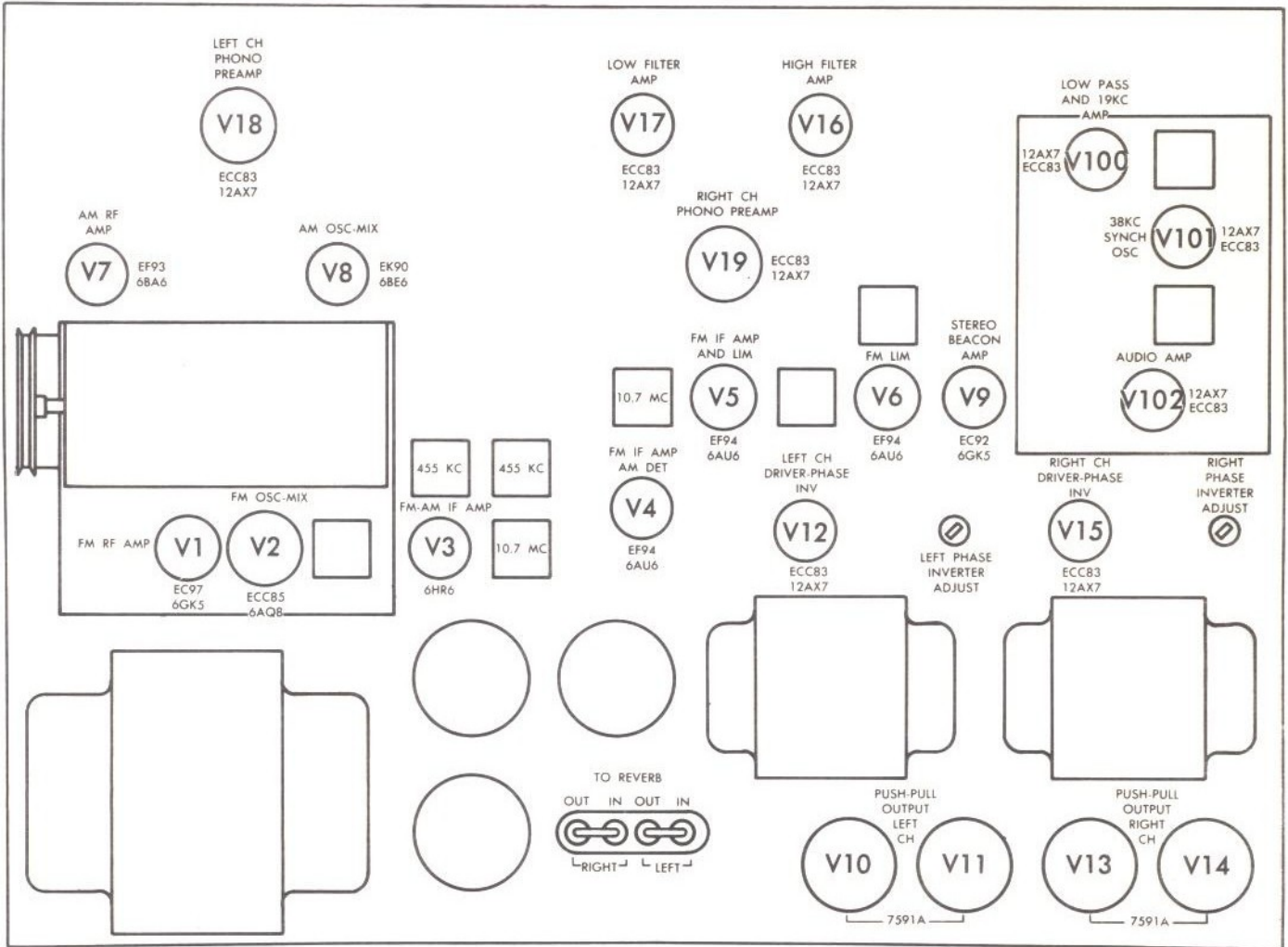

SERVICE NOTES



FISHER RADIO CORPORATION • NEW YORK

N 990-103

© 1963 FISHER RADIO CORPORATION

PRINTED IN U. S. A.

622-W12C-23