

SERVICE MANUAL

PRICE \$2.00

801

SERIAL NUMBERS
BEGINNING 10001

The Fisher® 801



Four-Channel Stereophonic AM-FM Receiver

WORLD LEADER IN HIGH QUALITY STEREO

	PAGE		PAGE
MECHANICAL DISASSEMBLY	3	MULTIPLEX	12
DIAL STRINGING	3	TUNER ALIGNMENT	14
HARMONIC DISTORTION TEST	3	PREAMP, AUDIO INPUT	16
CHASSIS LAYOUT	4	2+2 CHANNEL DECODER	18
SIGNAL FLOW	5	CONTROL AMP	18
POWER SUPPLY	6	AUDIO FILTER	20
AUTOSCAN	8	VOLUME	21
REMOTE CONTROL	9	POWER AMP, PRE-DRIVER	22
TUNER	10	PARTS LIST	24

CAUTION:

This precision high-fidelity instrument should be serviced only by qualified personnel, trained in the repair of transistor equipment and printed circuitry.

Many of these items are included only as a reminder — they are normal procedures for experienced technicians. Shortcuts may be taken, but these often cause additional damage to transistors, circuit components, or printed circuit boards.

SOLDERING: A well-tinned, hot, clean soldering iron tip will make soldering easier, without causing damage to the printed circuit board or the components mounted on it. Regular use of a sponge cleaner will maintain a clean soldering surface. The heat available at the tip, (not the wattage of the iron) is important. Some 50-watt irons reach temperatures of 1,000° F, while others will hardly melt solder. Small-diameter tips should be used for single solder connections, pyramid and chisel tips for large areas.

Always disconnect the AC power cord from the line when soldering. Turning the power switch OFF is not sufficient. Power-line leakage paths, through the heating elements of the iron, may destroy transistors.

PARTS REMOVAL: If a part is not being returned for in-warranty factory replacement, it may be cut in half (with diagonal cutting pliers) to make removal easier. Multiple terminal parts, such as IF transformers, or electrolytic capacitors, should be removed using special de-soldering tips made especially for this purpose. Removing solder from terminals, reduces the possibility of breaking the printed circuit board when the part is removed.

ACCIDENTAL SHORTS: A clean working area, free of metal particles, screws, etc., is an important preventive in avoiding servicing problems. Screws, removed from the chassis during servicing, should be stored in a box until needed. While a set is operating, it takes only an instant for a base-to-collector short to destroy a transistor (and others direct-coupled to it). In the time it takes for a dropped screw, washer, or screw-driver, to contact a pair of terminals (or terminal and chassis), a transistor can be ruined.

SOLID-STATE DEVICES: Integrated Circuits contain the equivalent of many circuit parts, including transistors, diodes, resistors, and capacitors. The preferred troubleshooting procedure requires isolating the trouble to one stage using AC signal tracing methods. Once the suspected stage is located the DC voltages at the input and output leads are measured to give an accurate indication of the operating conditions of the IC. DO NOT use an ohmmeter, to check continuity with the IC mounted on the printed circuit board. Forward biasing the internal junctions within the IC may burn out the transistors. Do not replace a defective IC until all external resistors, capacitors, and transformers are checked first, to prevent the replacement IC from failing immediately due to a defect in the connecting components. Solder and unsolder each lead separately using a pliers or other heat sink on the lead to

prevent damage from excessive heat. Check that the leads are connected to the correct locations on the printed circuit board before turning the set on.

Whenever possible, a transistor tester should be used to determine the condition of a transistor or diode. Ohmmeter checks do not provide conclusive data, and many even destroy the junction(s) within the device.

Never attempt to repair a transistor power amplifier module until the power supply filter-capacitors are fully discharged.

If an output or driver transistor becomes defective (opens or shorts), always check ALL direct-coupled transistors and diodes in that channel. In addition, check the bias pot., and other parts in the bias network, before installing replacement transistors. All output and driver transistors in one channel may be destroyed if the bias network is defective. After parts replacement, check bias for specified idling current.

In some applications, replacement of transistors must be made from the same beta group as the original type. The beta group is indicated by a colored marking on the transistor. Include this information when ordering replacements.

When mounting a replacement power transistor, be sure the bottom of the flange, mica insulator, and the surface of the heat sink, are free of foreign matter. Dust and grit will prevent flat contact, reducing heat transfer to the heat sink. Metallic particles can puncture the insulator, cause a short, and destroy the transistor.

Silicone grease must be used between the transistor and the mica insulator and between the mica and the heat sink for best heat transfer. Use Dow-Corning DC-3, or an equivalent compound made for power transistor heat conduction.

Use care when making connections to speakers and output terminals. To reduce the possibility of shorts, lugs should be used on the exposed ends, or stranded wire should be tinned to prevent frayed wire ends. Current in the speakers and output circuitry is quite high — poor contacts, or small wire, can cause significant power losses. For wire lengths greater than 30 feet, 16 AWG, or heavier, should be used.

VOLTAGE MEASUREMENTS: All voltages are measured with the line voltage adjusted to 120 volts. All measured voltages are $\pm 20\%$. DC voltages are measured to chassis with a VTVM, with no signal input unless otherwise noted. AC signal voltages are measured under the conditions specified on the schematic.

ALIGNMENT PROCEDURES: DO NOT attempt realignment unless the required test equipment is available, and the alignment procedure is thoroughly understood.

TEST EQUIPMENT and MECHANICAL DISASSEMBLY

The following equipment is required to completely test and align the 801 AM-FM Receiver.

- Line Voltage Autotransformer or Voltage Regulator
- DC Vacuum Tube Voltohmmeter
- Accurately Calibrated AC Vacuum Tube Voltmeter
- Oscilloscope (Flat to 100 KHz Minimum)
- Low-Distortion Audio (Sine Wave) Generator
- Harmonic Distortion Analyzer
- 2 — Load resistors, 4-Ohms, 100 Watt (Minimum Rating)

- AM/FM Signal Generator
- 10.7 MHz Sweep Generator (Fisher 3024*)
- Multiplex Generator with RF output (Fisher 1536*)
- 455 KHz Sweep Generator (Fisher 3025*)
- Stereo Source — Turntable, Tape Recorder, etc.
- Soldering Iron with Small Tip, Fully Insulated from AC Line
- Suction Desoldering Tool

* with Power Supply (Fisher 1561)

REMOVING DRESS PANEL

- (1) Remove the screws securing the cabinet to chassis and remove cabinet.
- (2) Gently pull TAPE MONITOR, SELECTOR, MODE, BASS, TREBLE, BALANCE, SPEAKERS, TUNING, and VOLUME knobs from their control shafts. Remove hex nuts from shafts.
- (3) Unscrew hexagonal spacers (2) at top left and top right of dial bracket. Remove dress panel.
- (4) Reverse procedure for re-assembly.

REPLACING DIAL GLASS

- (1) Remove dress panel.
- (2) Remove left and right dial glass retainers and remove dial glass.
- (3) Install a new dial glass by reversing procedure.

REPLACING DIAL LAMPS

- (1) Remove the screws securing the cabinet to chassis and remove cabinet.
- (2) Remove lamp assembly leads from pins 50 and 51. Note the position of wires taped against the metal bracket.
- (3) Snap out defective lamp assembly from the rear of bracket. Insert a new lamp assembly and connect leads to pins 50 and 51. Tape wires against metal bracket as noted in step (2).
- (4) Replace dress panel.

REPLACING DIAL POINTER LAMP

- (1) Remove the screws securing the cabinet to chassis and remove cabinet.
- (2) Remove lamp assembly leads from pins 51 and 53.
- (3) Bend metal flap back and remove wire support from the metal bracket behind dial glass.
- (4) Remove dial cord from tab on dial pointer. Carefully disengage pointer assembly and pull free of dial bracket.
- (5) Remove the wire that retains sleeving in lamp housing. Snap out lamp assembly from housing and remove.
- (6) Re-assemble new lamp assembly in reverse order.
- (7) Check pointer adjustment. Refer to DIAL STRINGING.

REPLACING STEREO BEACON, 2-CH, 4-CH, AND MONO LAMPS

NOTE: The indicator assembly above the meter contains all four lamps and must be replaced as a unit.

- (1) Remove the screws securing the cabinet to chassis and remove cabinet.
- (2) Disconnect three lampholder assembly leads from pins 56, 16, and DD on tuner board and three leads from pins 39, 40, and 41 on control amplifier board. Label each wire for reference.
- (3) Remove the two nuts securing indicator assembly to dial bracket and remove assembly.
- (4) Insert new indicator assembly and connect leads to the tuner and control amplifier boards as labeled. Replace cover.

REPLACING METER LAMPS

NOTE: The lampholder assembly at the rear of the meter contains both the autoscan and meter lamps, and must be replaced as a unit.

- (1) Remove the screws securing the cabinet to chassis and remove cabinet.
- (2) Remove lampholder assembly leads from pins 16, DD, 30, and 5V on tuner board. Label wires for reference.
- (3) Gently lift retaining spring that holds lampholder assembly at rear of meter and remove assembly.
- (4) Insert new lampholder assembly under the retaining spring and re-connect wires.

REPLACING METER

- (1) Remove the screws securing the cabinet to chassis and remove cabinet.
- (2) Remove lampholder assembly from rear of meter.
- (3) Remove meter leads from pins 26 and 28 on tuner board. Label wires for reference.
- (4) Gently pry meter from the back of dial panel and scrape residual adhesive from panel. Transfer meter leads to new meter.
- (5) Peel backing from one side of replacement adhesive mounting pad and affix it to replacement meter. Peel backing from other side of pad, align meter face over panel cutout, and press meter firmly to back of panel.
- (6) Re-connect meter leads to tuner board.
- (7) Replace lampholder assembly.
- (8) Check meter calibration. Refer to TUNER ALIGNMENT. Replace cover.

REMOVING PC BOARDS

To remove most boards, disconnect leads and remove screws securing board to its mounts. Label all wires for reference. Some boards have guide pins or front panel controls and require additional removal procedures as follows:

VOLUME CONTROL BOARD

NOTE: The volume control board on the front panel contains both left and right volume controls and must be replaced as a unit.

- (1) Remove dress panel.
- (2) Remove the screw securing connector board to autoscan board. Disconnect connector board.
- (3) Remove the four screws securing volume control board to dial bracket. Remove board.
- (4) Replace in reverse order.

TUNER BOARD

- (1) Disconnect wiring and label for reference.
- (2) Remove connecting board.
- (3) Remove dial cord.
- (4) Remove eleven screws securing board to its mounts and lift board straight up.
- (5) Reverse procedure to replace.
- (6) Restring dial cord. Refer to DIAL STRINGING procedure.

AUTOSCAN BOARD

- (1) Remove dress panel.
- (2) Remove volume control board.
- (3) Remove screws securing connector boards and remove connectors.
- (4) Remove two screws securing AUTOSCAN TUNING pushbuttons.
- (5) Remove screws securing autoscan board to its mounts and remove board.
- (6) Replace in reverse order.

AUDIO FILTER BOARD

- (1) Remove dress panel.
- (2) Remove the screws securing bottom cover to chassis. Remove cover.
- (3) Remove insulator cover from audio filter.
- (4) Remove the screws securing remote pick-up board to audio filter.
- (5) Remove the screws securing HIGH FILTER, LOUDNESS, and MUTING pushbutton bracket.
- (6) Remove the screws securing audio filter board to mounts and remove board.
- (7) Replace in reverse order.

CONTROL AMPLIFIER BOARD

- (1) Remove audio filter board.
- (2) Remove hex nuts that secure extender shafts of TAPE MONITOR, SELECTOR, and SPEAKERS switches to chassis front panel. Remove couplings that secure extender shafts to switch shafts. Pull extender shafts out toward the rear.
- (3) Disconnect the lamp leads from pins 39, 40, and 41 and the decoder leads from the decoder terminals. Label all leads for reference.
- (4) Carefully remove (pull up) red slide-restrainer on 12-pin printed circuit board connector interconnecting audio input board. Slide connector to the side that disconnects pins on the control amplifier board.
- (5) Remove hex nuts securing BALANCE and MODE switch shafts to chassis front panel.
- (6) Remove screws securing the control amplifier board to its mounts. Lift up rear of board to clear switch shafts and remove board.
- (7) Replace in reverse order.

AUDIO INPUT BOARD

- (1) Remove dress panel. Remove the screws that secure bottom cover to chassis. Remove cover.
- (2) Remove hex nuts that secure the extender shafts of TAPE MONITOR and SELECTOR switches to chassis front panel. Remove coupling holding extender shafts at other end.
- (3) Carefully remove (pull up) red slide-restrainers on 6-pin and 12-pin printed circuit board connectors. Slide connectors to the side that disconnects pins to the audio input board.
- (4) Remove three screws holding input/output jack connector board on the rear panel.
- (5) Remove eight screws securing the audio input board to its mounts. Remove board with input/output jacks from chassis.
- (6) Replace in reverse order.

POWER SUPPLY BOARD

- (1) Remove dress panel. Remove screws securing bottom cover to chassis and remove cover.
- (2) Remove hex nut securing extender shaft of SPEAKERS switch to chassis front panel. Remove coupling holding extender shaft at other end.
- (3) Disconnect leads from pins on power supply board and leads from board to SPEAKERS terminals on rear panel. Label all wires for reference.
- (4) Carefully remove (pull up) red slide-restrainer on 6-pin printed circuit board connector. Slide connector to the side that disconnects pins on power supply board.
- (5) Remove four screws securing rear panel to chassis. Bend back rear panel.
- (6) Remove screws securing 2+2 channel decoder bracket and move decoder clear of power supply.
- (7) Remove eleven screws securing power supply board to chassis mounts and remove board.
- (8) Replace in reverse order.

DIAL STRINGING

- (1) Remove the screws securing top cover to chassis. Remove cover.
- (2) Rotate tuning capacitor fully CCW. Loosen screw in center of drum and remove old dial cord.
- (3) Tie end of new cord to end of dial spring. Fasten spring to bottom right ear inside drum. See illustration.
- (4) Run cord through rim slot into underside of groove 2. Guide cord around pulley "A", under pulley "B", and wrap two turns CCW around tuning shaft. See detail.
- (5) Guide cord under and around pulley "C", and around pulley "D". Keep cord taut.
- (6) Rotate drum fully CW, allowing cord to wind onto drum.
- (7) Guide cord over drum into groove 5, through rim slot, and under washer. See illustration.
- (8) Pull cord taut, and tighten screw.
- (9) Rotate drum CCW and CW to distribute tensioning.
- (10) Repeat (8) and (9) until spring is tensioned.
- (11) Place cord over tab on pointer. Rotate tuning shaft CCW. Slide pointer to 0 while holding tuning shaft fully CCW.
- (12) Check dial calibration. Refer to TUNER ALIGNMENT.

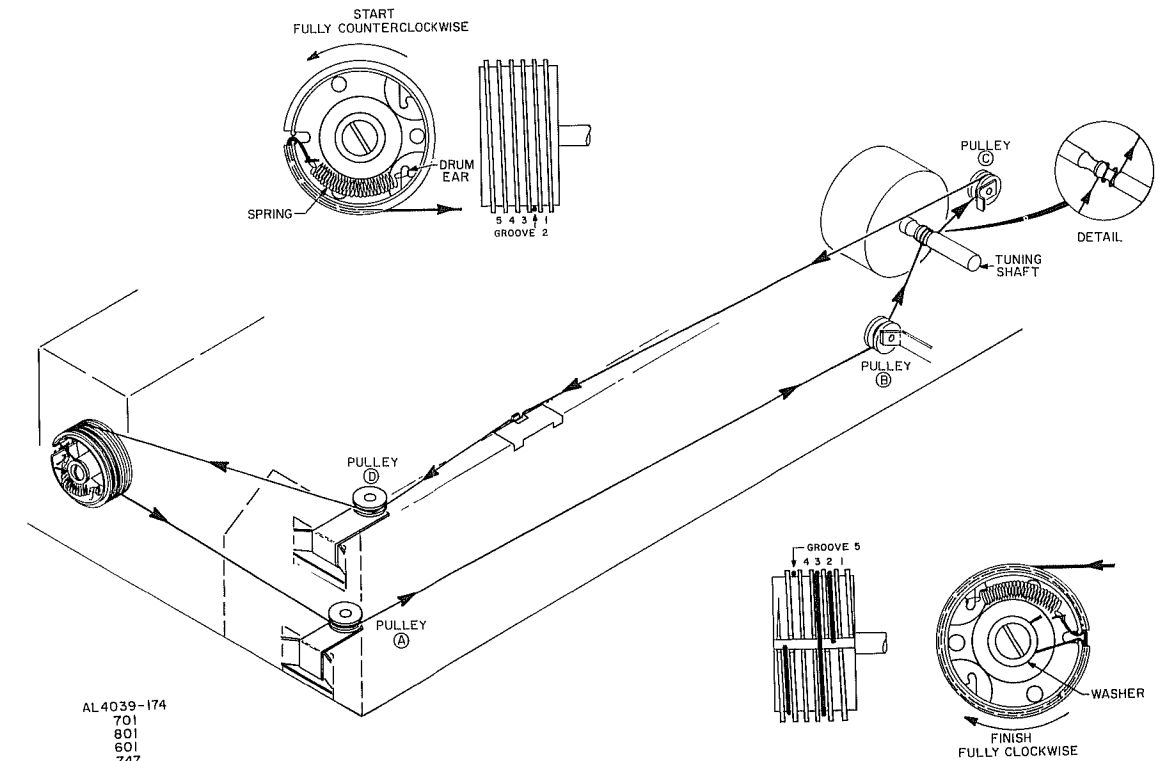

HARMONIC DISTORTION TEST 3

CAUTION:

- (A) Test one channel at a time.
- (B) Limit tests to 10 minutes.
- (C) Use a load with a minimum power rating of 100 watts.

- Unplug AC power cord. Release all pushbuttons. Slide FRONT and REAR VOLUME controls to 0. Set BASS, TREBLE, and BALANCE to their center positions. Set TAPE MONITOR to OFF, SELECTOR to AUX 1, MODE to 4-CH STEREO, and SPEAKERS to MAIN.
- (1) Connect a low-distortion sine-wave generator to the AUX 1 IN-FRONT L jack. Set generator frequency to 1kHz, and output level to minimum.
 - (2) Connect a 4-ohm load resistor between MAIN SPEAKERS-FRONT L and COMMON terminals. Connect a harmonic distortion analyzer and an AC VTVM across the load.
 - (3) Connect AC power cord and slide FRONT VOLUME to maximum.
 - (4) Increase generator output for 50 watts RMS (14.1V across 4-ohm load). HD meter should indicate 1% or less.
 - (5) Repeat preceding steps for FRONT R, REAR L, and REAR R channels.

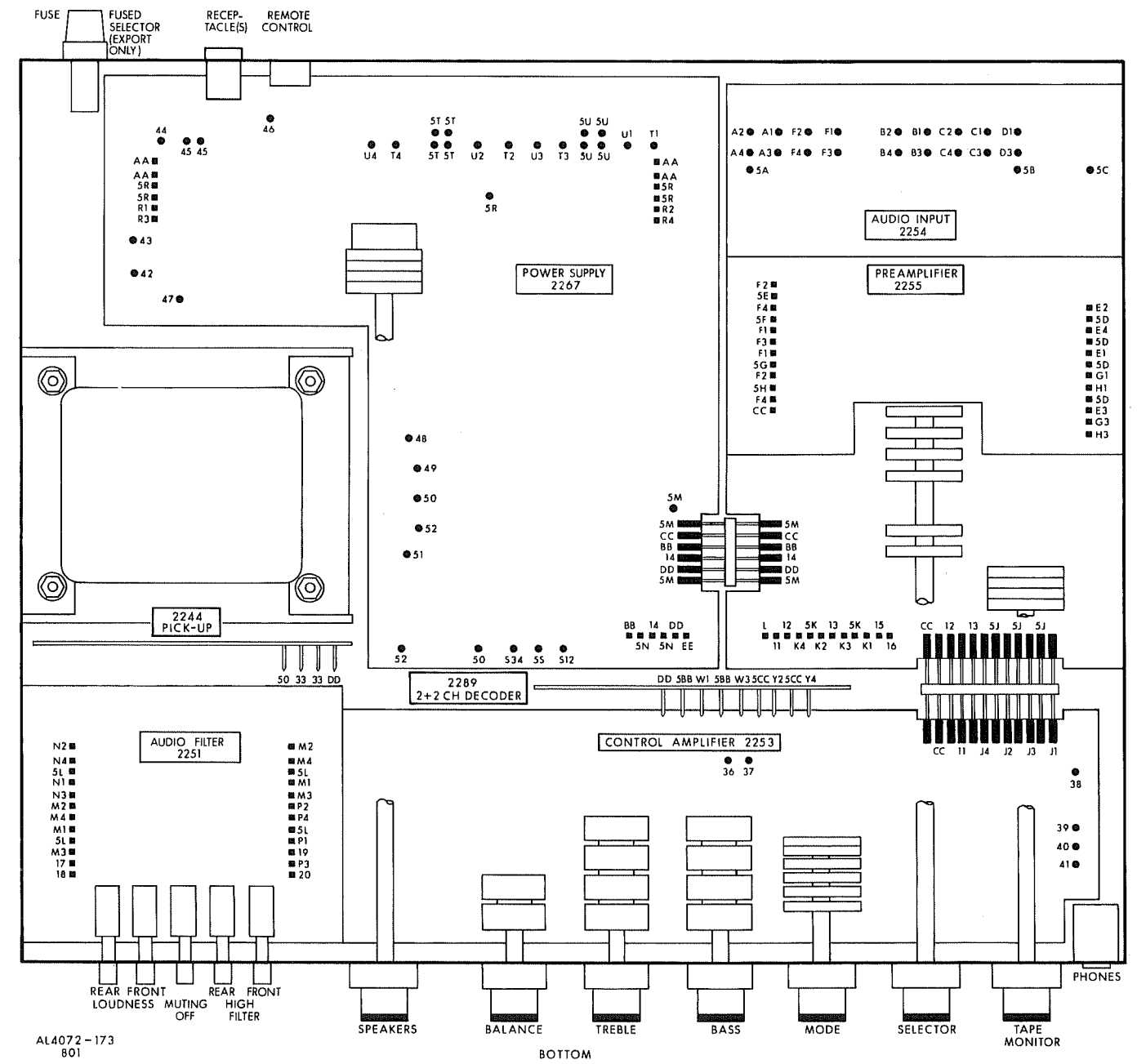
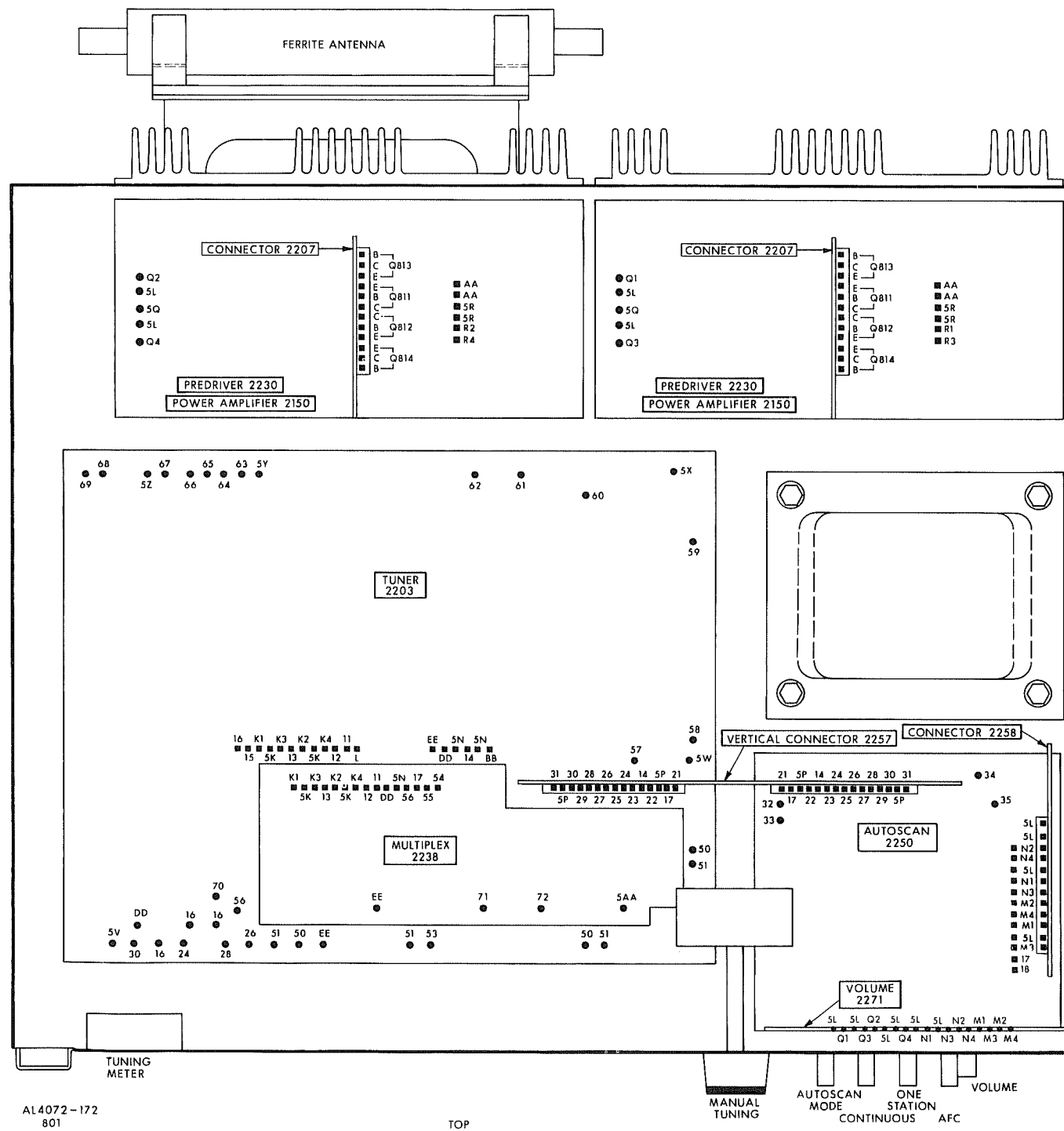

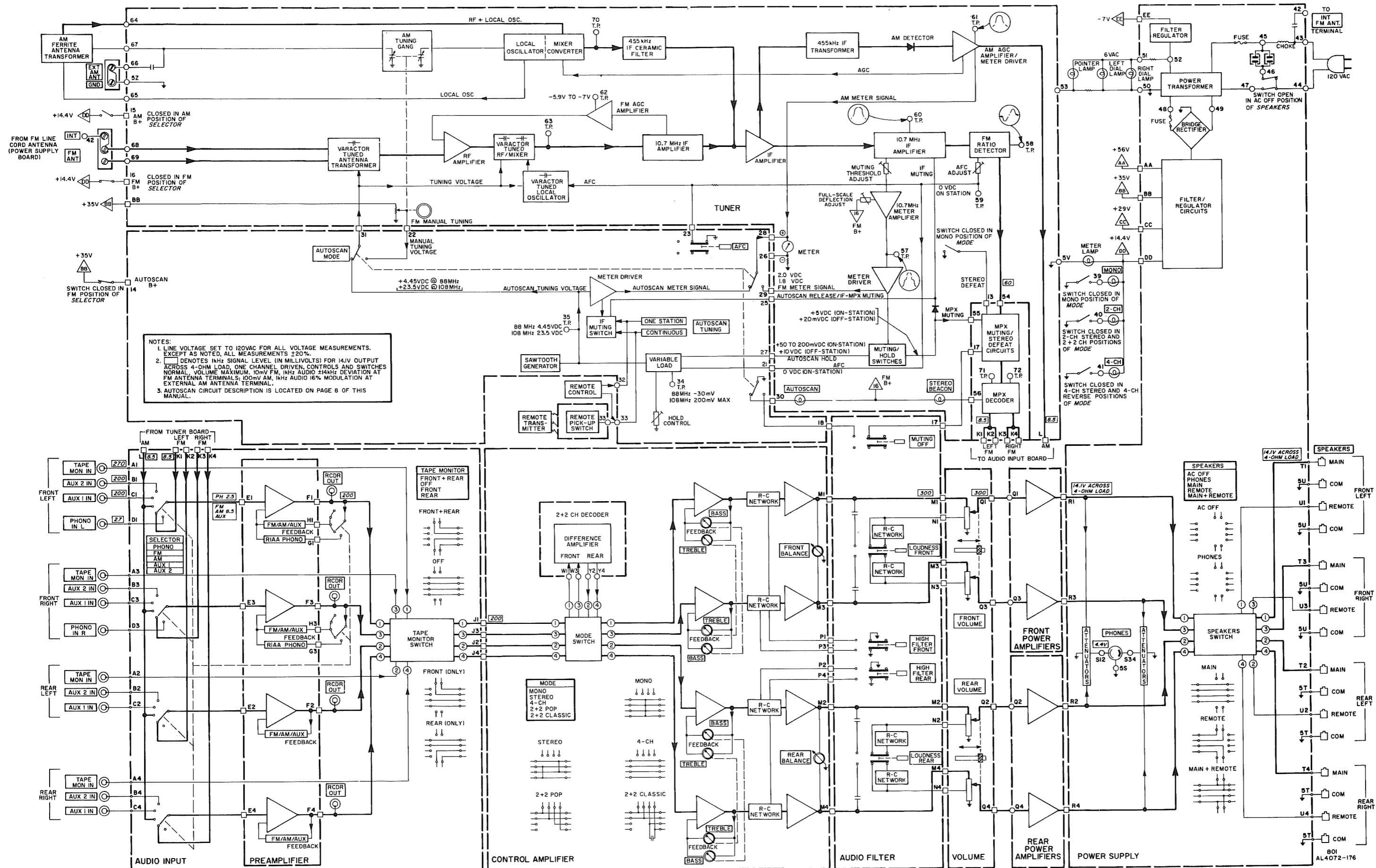

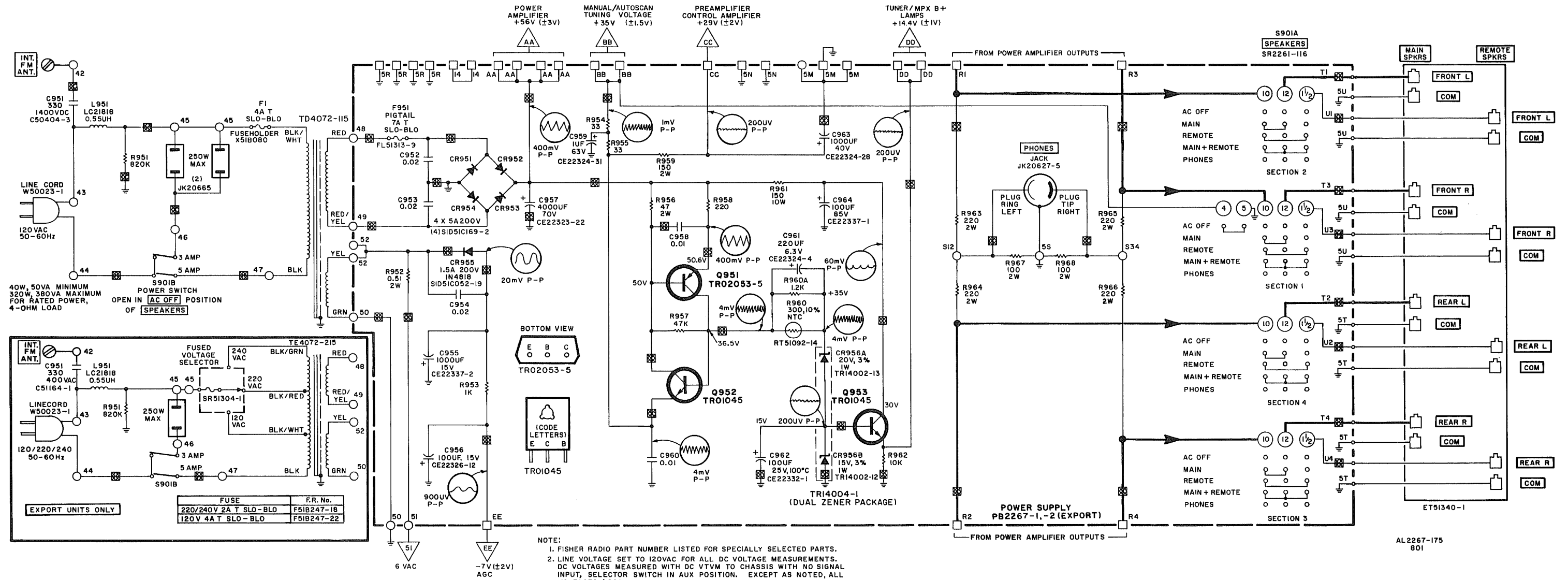

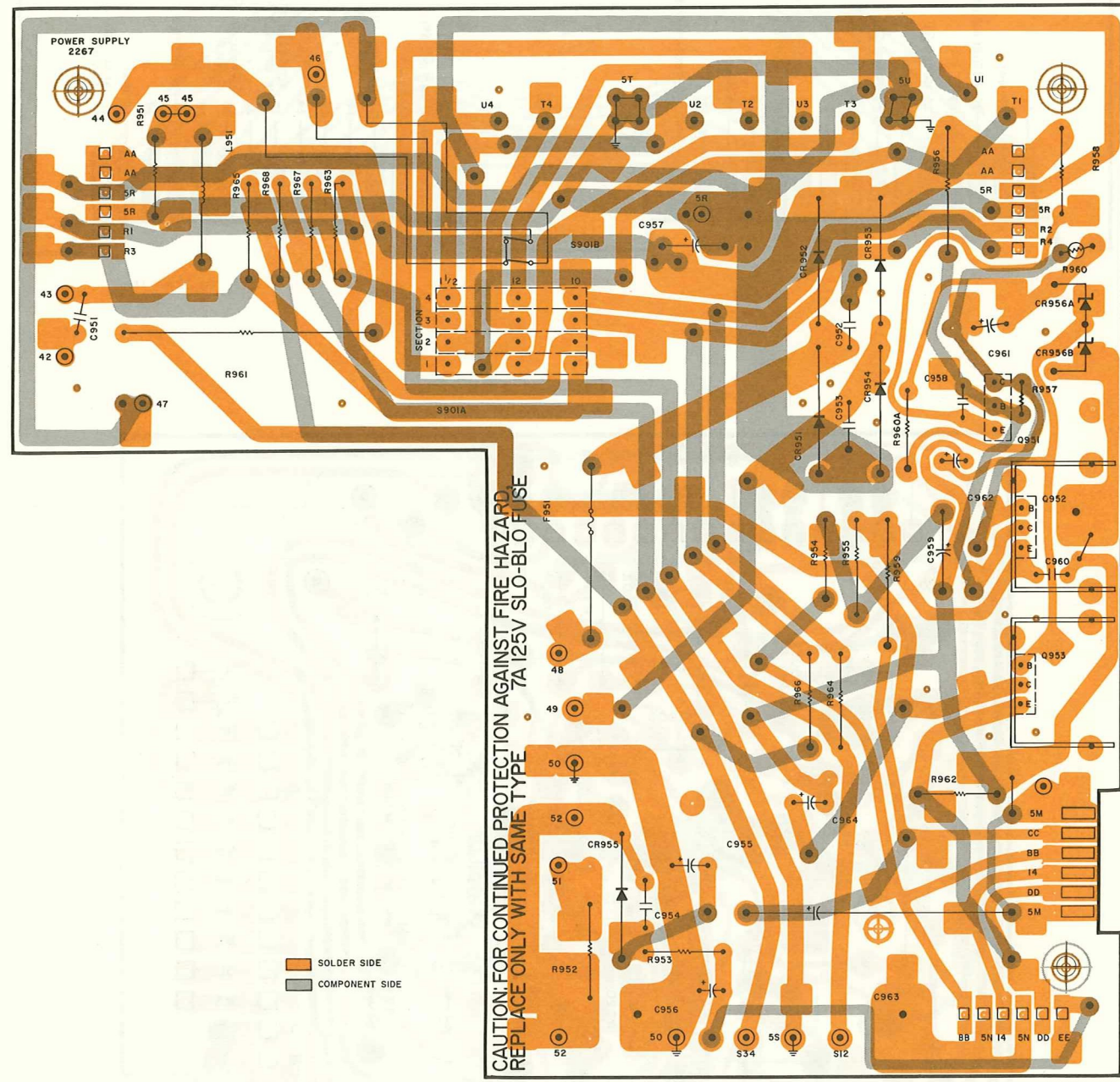

CIRCUIT DESCRIPTION

The 801 utilizes variable-capacitance diodes, called varactors, to tune the FM RF circuitry. When reverse-biased, these diodes exhibit a change in capacity as the reverse-bias voltage is changed (i.e. increasing voltage decreases capacity). The front-end, therefore, is tuned by an applied DC 'tuning' voltage instead of a mechanical tuning gang. The AUTOSCAN circuit generates and controls the tuning voltage.

Transistor Q903 provides a constant-current charging source for storage capacitor C902. As the tuning voltage on C902 rises, the front-end tunes upscale toward 108MHz. When the tuning voltage rises to approximately +24V (108.5MHz), the emitter peak-point voltage of unijunction transistor Q902 is reached and C902 is discharged (through Q902) to approximately 3 volts, resetting the circuit. Q902 resumes its normal operating state (essentially open-circuit) and the charging cycle repeats. The precise reset voltage (and the resulting frequency) is adjusted by HIGH LIMIT control R908.

Field-effect transistor Q901 functions as a variable load across the constant current charge source. The gate of Q901 is DC-coupled to the output of the ratio detector. When the output voltage of the detector sweeps to zero (exact center of station), Q901 loads the charging source to maintain a constant tuning voltage on C902. The hold control, R906, is adjusted to set the load current equal to the charge current (constant tuning voltage) when the gate voltage is zero. The source of Q901 is connected through R903 to the autoscan hold circuit. When the receiver is tuned on-station, the hold voltage is approximately zero. When the receiver is tuned off-station, the hold circuit is released, and the hold voltage steps rapidly to +10 volts. This biases Q901 to minimum load conditions, and allows the tuning voltage to rise. At the next desired station, the hold and detector voltages swing to zero, and Q901 loads Q903 to establish and hold the tuning voltage.

The emitter of Q906 is DC-coupled to the input of the autoscan hold circuit. On-station, Q906 is reverse-biased. Pressing the CONTINUOUS pushbutton grounds the base and forward-biases Q906. The resulting low voltage on the emitter releases the hold circuit and allows the receiver to scan. In addition, Q906 mutes the IF and multiplex circuits. Pressing the ONE STATION pushbutton grounds the base of Q906 through R924 and R925. The time during which the hold circuit is released is sufficiently long to allow the receiver to tune off-station, and is short enough to prevent station skipping. This time is determined by the charging rate of C903. As the voltage across C903 rises, Q906 resumes reverse-bias conditions, causing the hold circuit to become operative.

To sweep 1MHz requires a change in tuning voltage of approximately 1/2 volt at 88MHz, and approximately 1 1/2 volts at 108MHz. Therefore, tuning time varies about 1:3 between 88MHz and 108MHz. The corresponding release time at 108MHz must be three times longer than at 88 MHz. Variable timer transistor Q905 progressively lowers the voltage applied to C903, and lengthens the release time at 108 MHz.

To eliminate switch noise, the IF and multiplex circuits are momentarily disabled by the mute switch whenever the AUTOSCAN MODE switch is actuated.

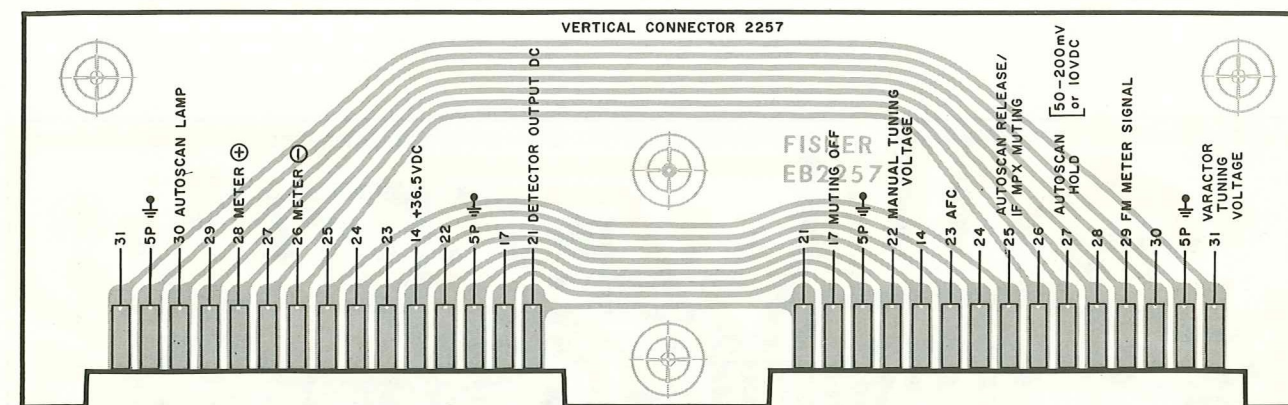

AL2257-III

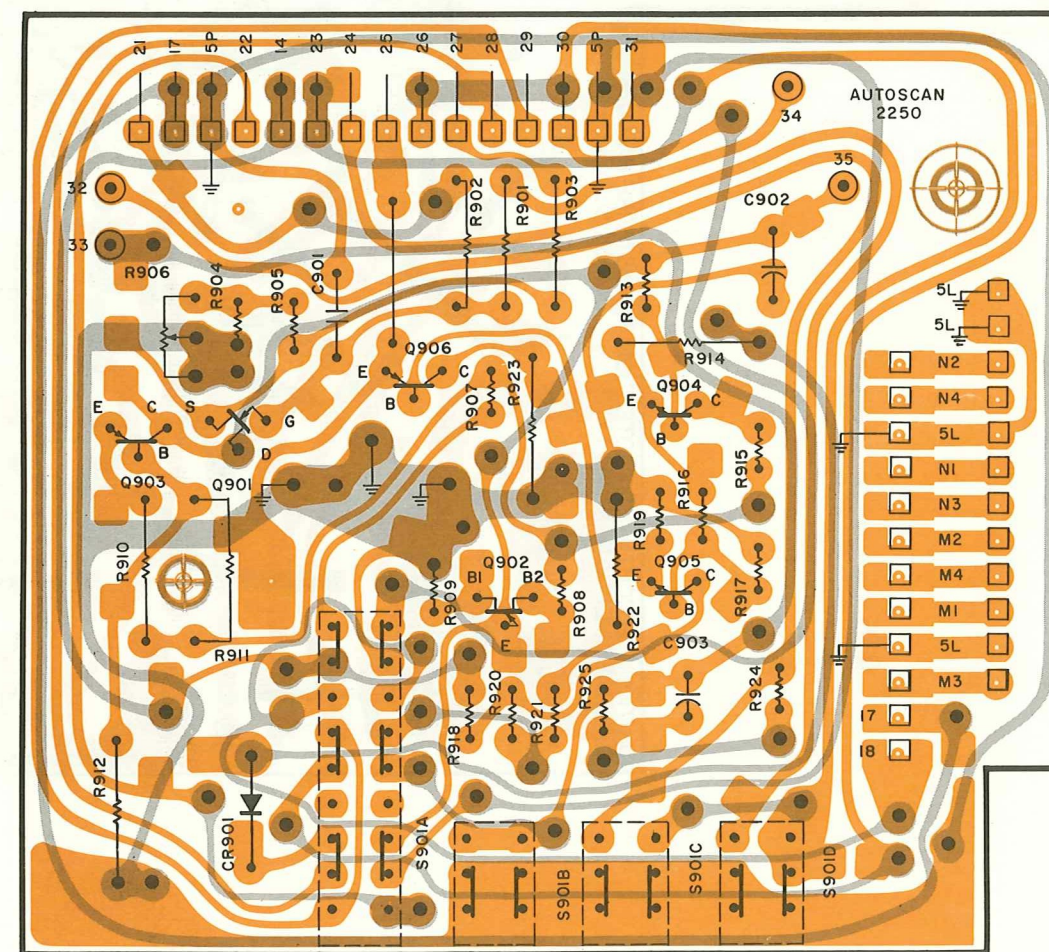

AL2250-III

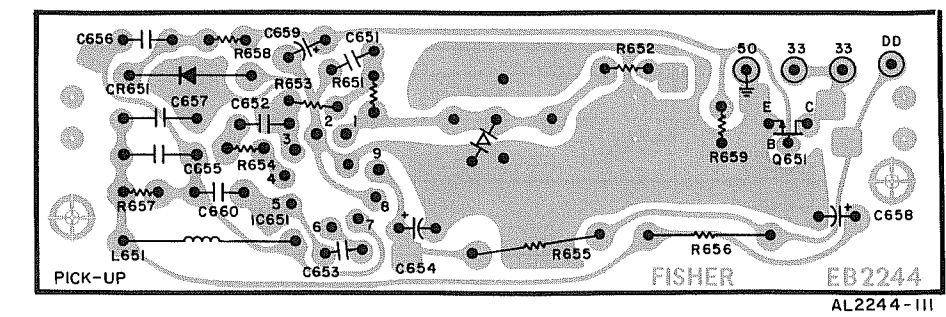
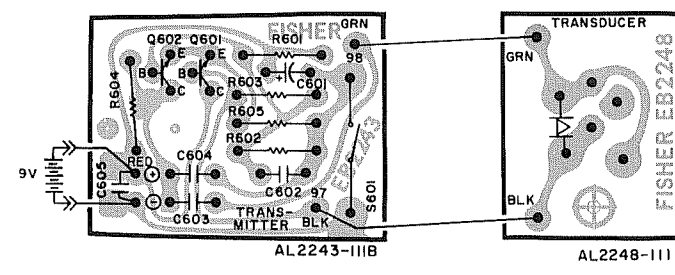
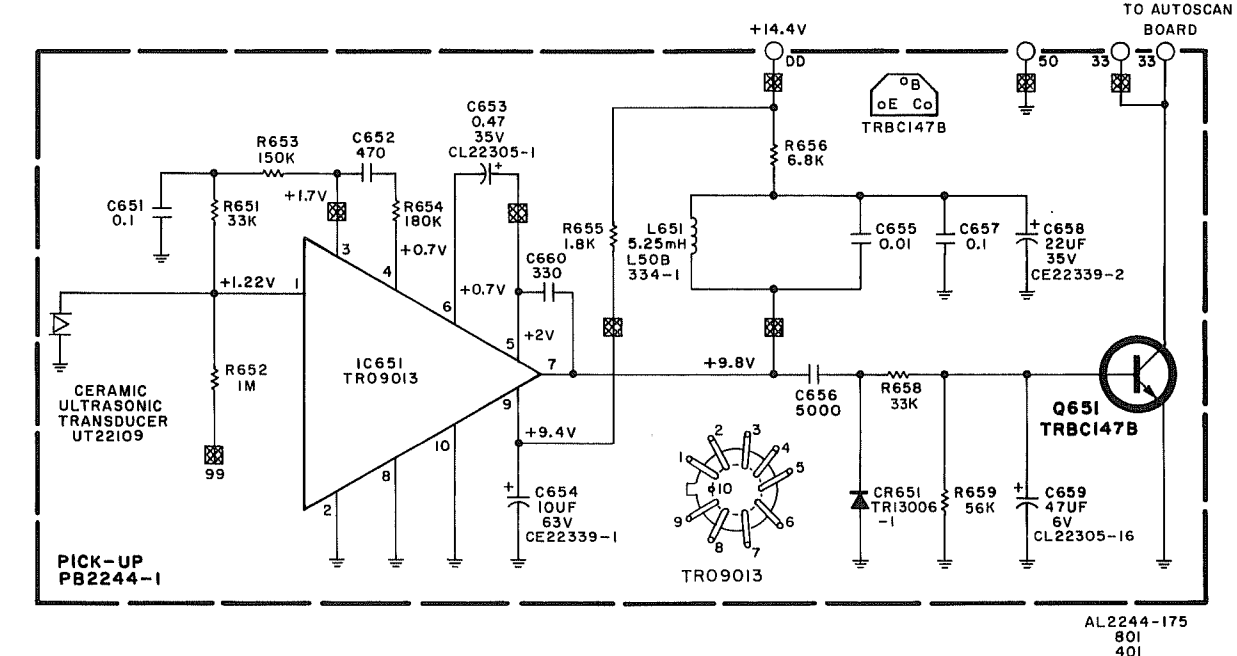
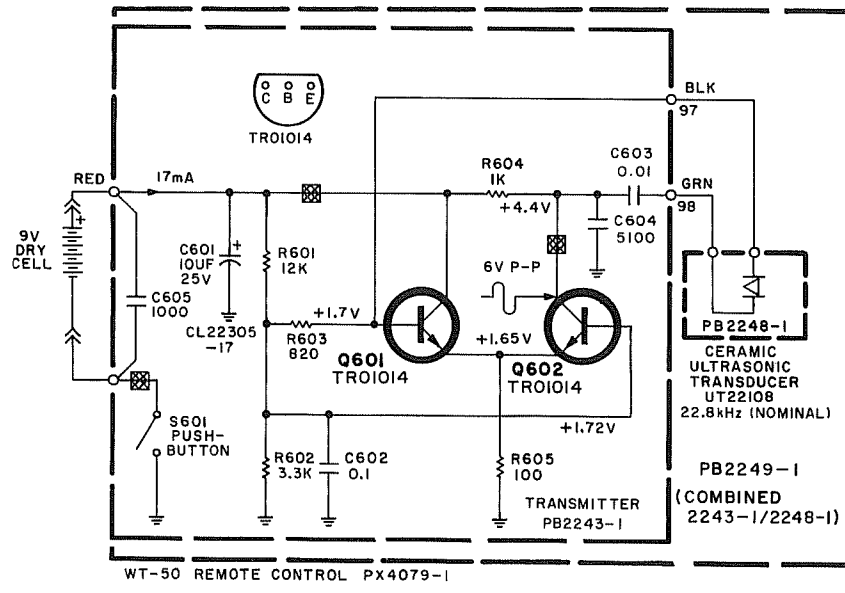
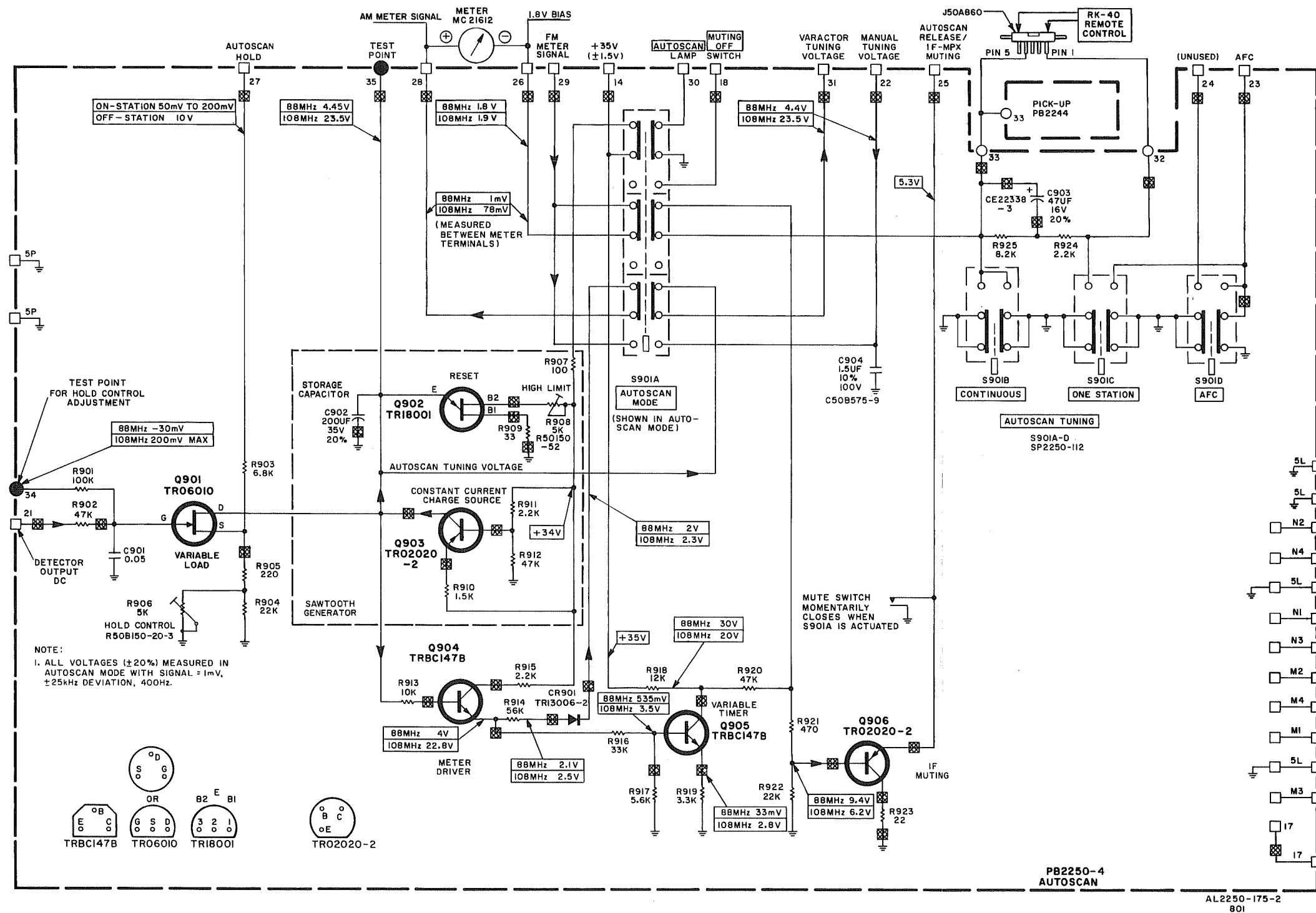

A similar ceramic ultrasonic transducer in the pick-up circuit responds to the transmitted signal by generating a voltage at 22.8 kHz. This signal is amplified by IC651 and then detected and filtered to produce a positive voltage at the base of Q651. This voltage turns on and saturates Q651. The Q651 emitter is connected to ground and its collector to the autoscan control circuit through pin 33. When Q651 is saturated, a ground is applied to the control circuit. The ground provides the same function as pressing the receiver CONTINUOUS pushbutton during local autoscan tuning.

Transistors Q601 and Q602 in the remote control transmitter function as an oscillator which produces pulses at 22.8 kHz when pushbutton S601 is depressed. The Q602 collector is capacitively coupled to pulse the ceramic transducer, and positive feedback is coupled from the transducer back to the base of Q601 to control and maintain oscillations at the natural resonant frequency of the transducer. The ceramic transducer radiates a 22.8 kHz signal towards the receiver.

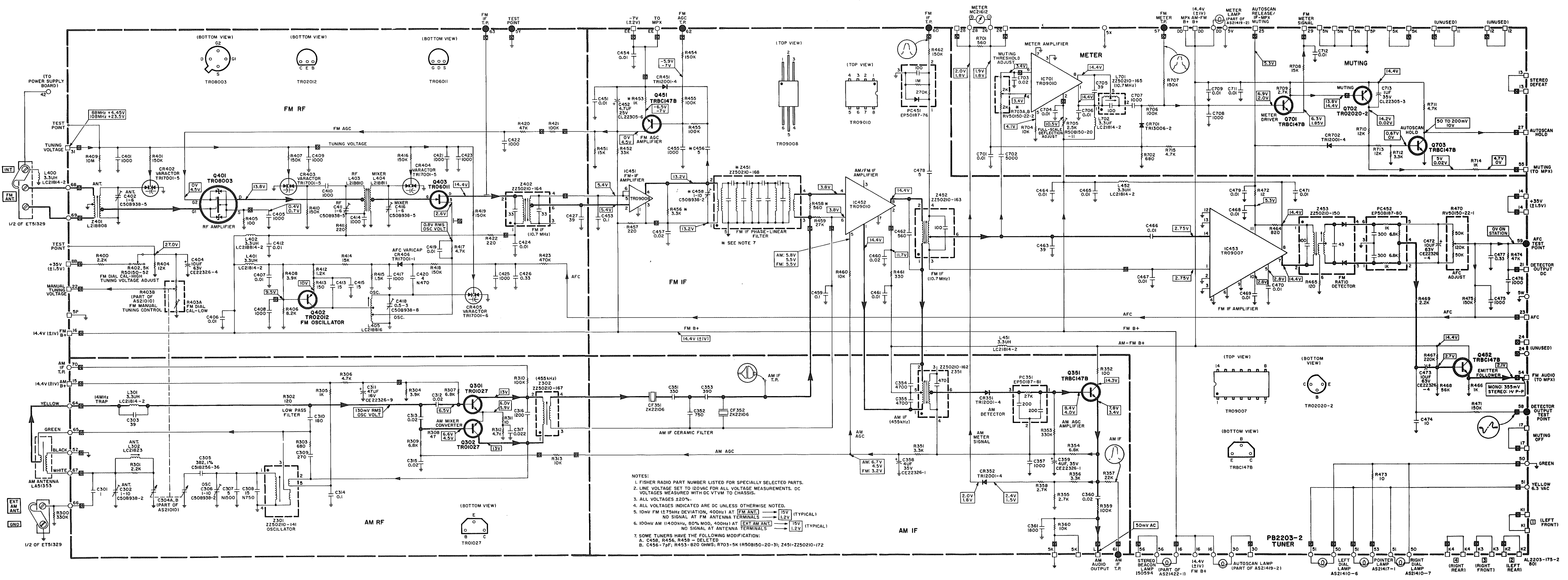

- NOTES:
1. FISHER RADIO PART NUMBER LISTED FOR SPECIALLY SELECTED PARTS.
 2. LINE VOLTAGE SET TO 120VAC FOR ALL VOLTAGE MEASUREMENTS. DC VOLTAGES MEASURED WITH DC VTVM TO CHASSIS.
 3. ALL VOLTAGES $\pm 20\%$.
 4. ALL VOLTAGES INDICATED ARE DC UNLESS OTHERWISE NOTED.
 5. 10mV FM (4.75kHz DEVIATION, 400Hz) AT [FM ANT.] (TYPICAL)
NO SIGNAL AT FM ANTENNA TERMINALS \rightarrow [1.5V] (TYPICAL)
 6. 100mV AM (1400Hz, 80% MOD, 400Hz) AT [EXT AM ANT.] (TYPICAL)
NO SIGNAL AT ANTENNA TERMINALS \rightarrow [1.2V] (TYPICAL)
 7. SOME TUNERS HAVE THE FOLLOWING MODIFICATION:
A. C458, R456, R459 - DELETED
B. C456-7pF; R453-820 OHMS; R703-5K (R50B150-20-3); Z451-Z250210-172

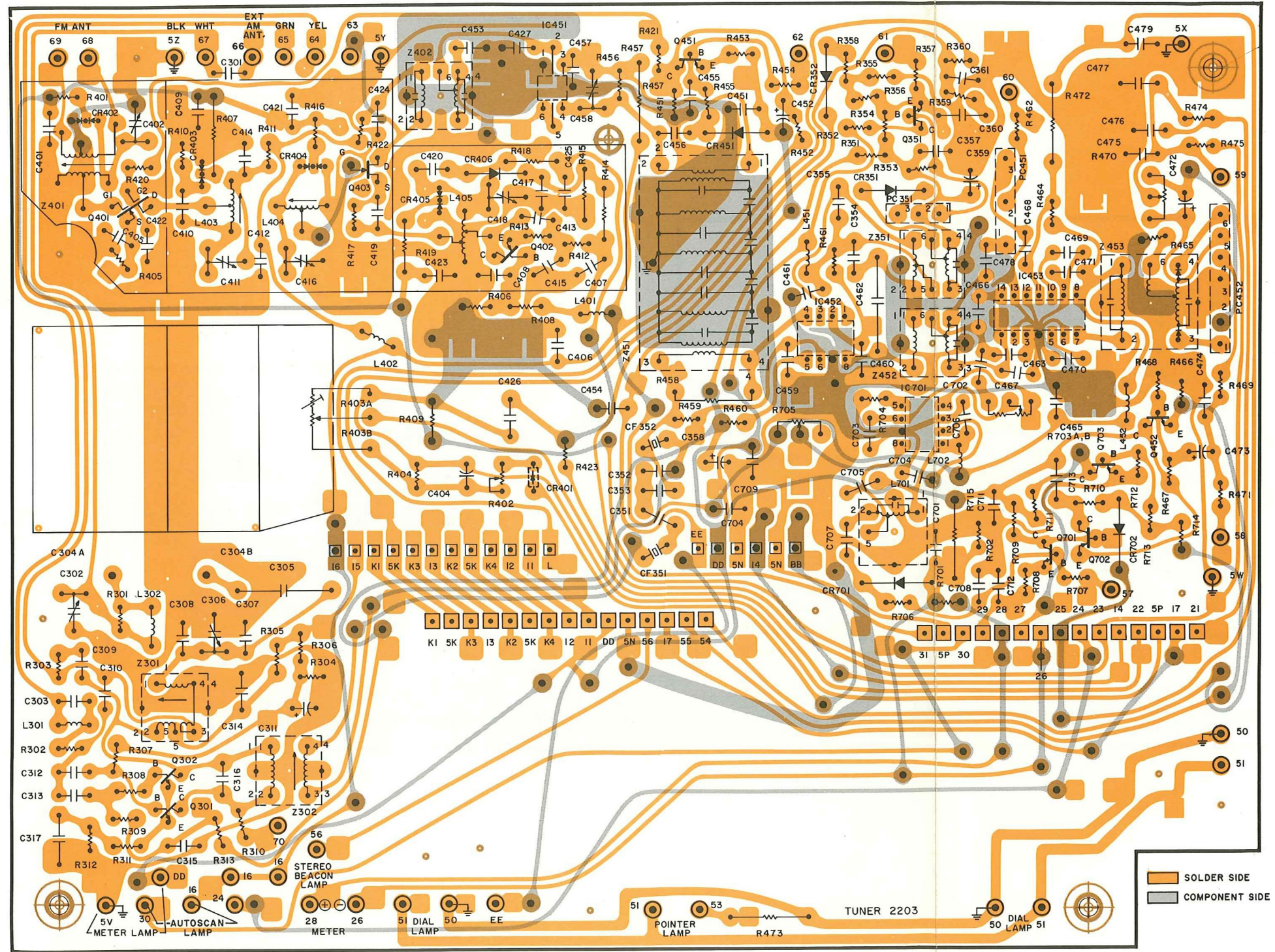

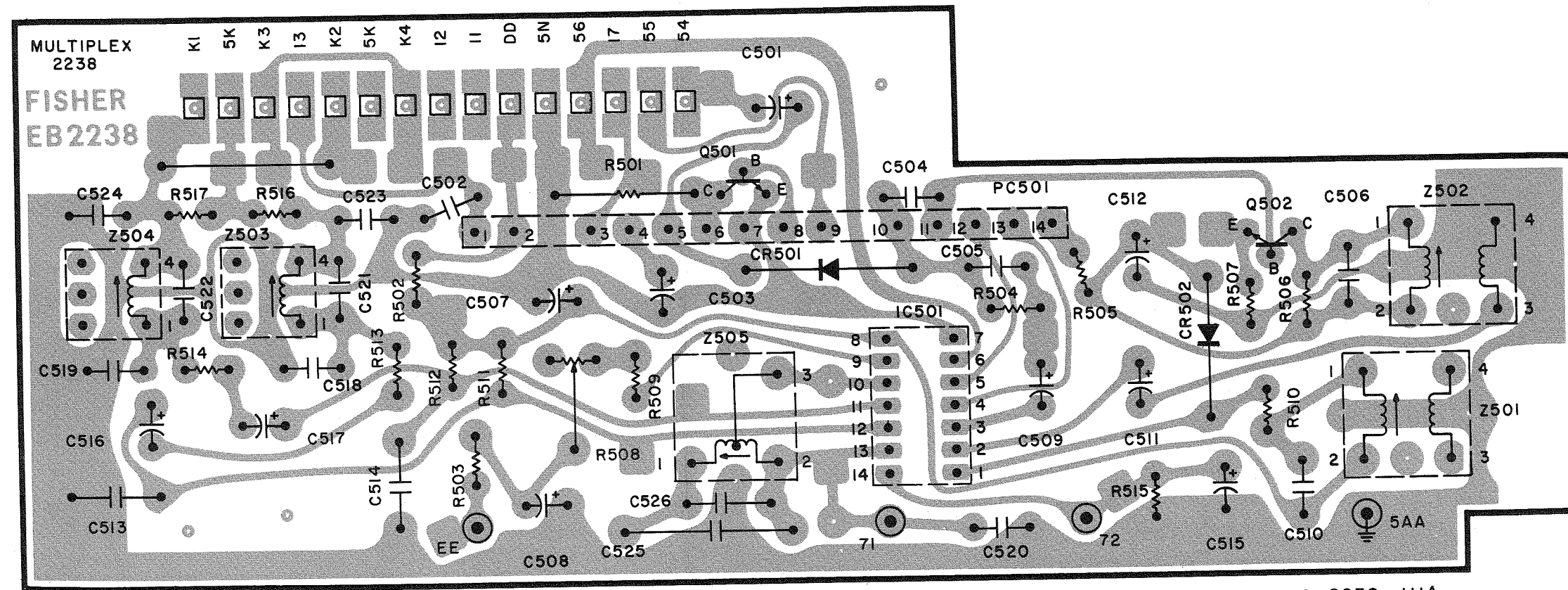

AL2238-111A

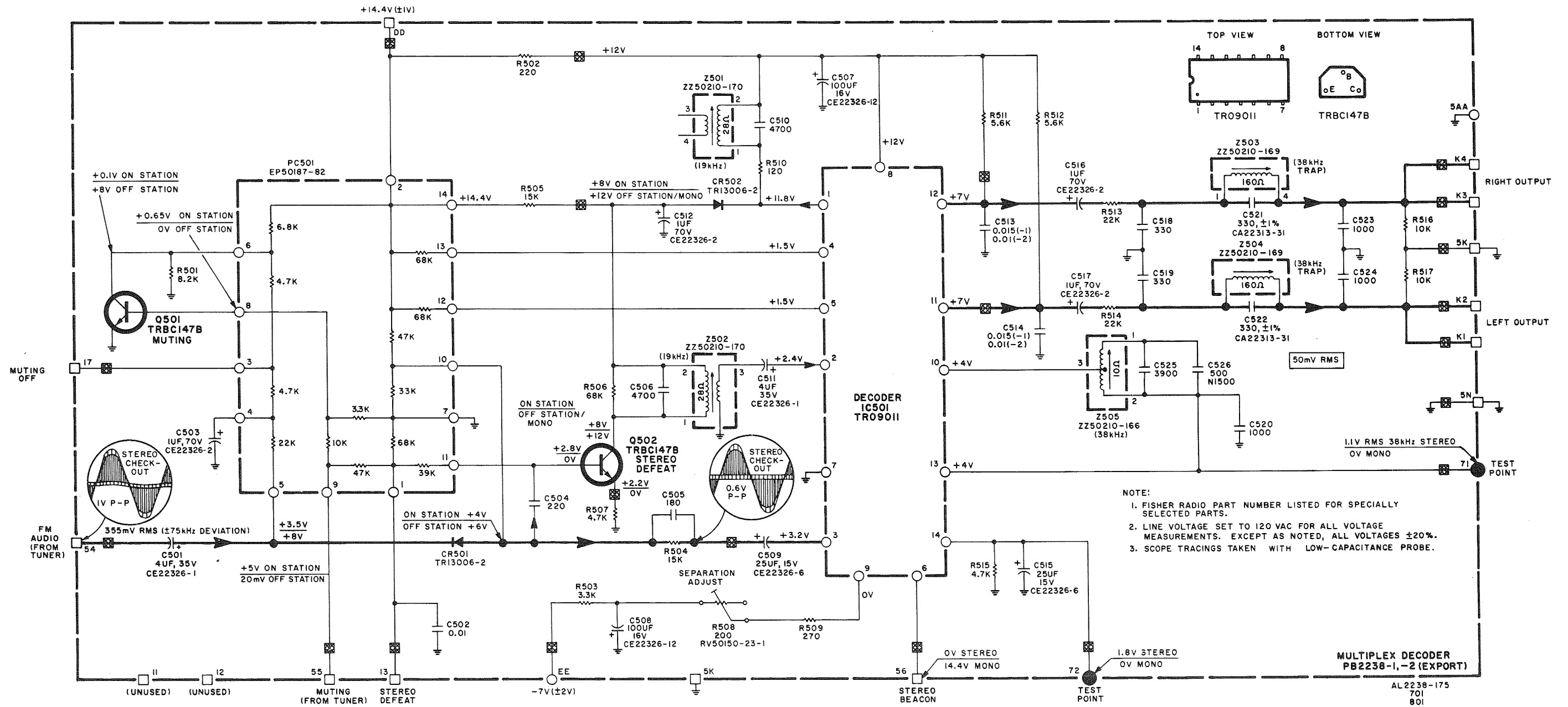

FM ALIGNMENT - SELECTOR to FM, MODE to MONO, MUTING OFF depressed, all others released (manual tuning), FRONT and REAR VOLUME to 0.

Maintain generator output as low as possible for suitable indication.

STEP	GENERATOR	DIAL SETTING	INDICATOR	ADJUSTMENT
1.	10.7 MHz sweep to pin 63, gnd to 5Y	Position of non-interference near 88 MHz	Scope vert dc input to pin 60, gnd to 5X	Z402, Z452 (top and bottom), and C458 (if used) for max gain and symmetry. See FM IF response.
2.	Increase to full output (approx 1 V)	"	"	Readjust Z452 if necessary. See FM IF-LIMITED response.
3.	Reduce to minimum output for suitable indication	"	"	Readjust Z402 for max gain and symmetry.
4. DETECTOR	"	"	DC VTVM and scope vert input to pin 58, gnd to 5W	Z453 top, bottom for max gain and symmetry. See FM DETECTOR response.
5.	Turn off sweep	"	DC VTVM to lowest (most sensitive) range	Readjust Z453 top for 0 VDC.
6. AFC	"	"	DC VTVM to pin 59, gnd to 5X. Use lowest (most sensitive) range.	R470 AFC ADJUST for 0 VDC.
7. METER IF	10.7 MHz, no sweep, output as low as possible	"	DC VTVM to pin 57, gnd to 5X.	Z701 for max gain. Note: If no signal verify that R703 is not fully CCW.
8. DIAL CALIBRATION		MANUAL TUNING fully CCW		Center pointer on 0 and cement
9.		Center of 108 MHz calibration mark	DC VTVM to pin 31 (top of R409)	R402 FM DIAL CAL-HIGH for 23.5 VDC
10.		Center of 88 MHz calibration mark		R403A FM DIAL CAL-LOW for exactly 4.43 VDC. Repeat steps 9 and 10 until correct voltages are obtained.
NOTE: 120-ohm composition resistors in series with each lead from RF generator match 50-ohm output to 300-ohm input impedances. Generator output voltage is reduced to one-half at antenna terminals. Signal voltages are generator output levels, not antenna voltages.				
11. FRONT END	FM generator to FM ANTenna terminals through 120-ohm composition resistors. Set to 90 MHz. Modulate with 400 Hz, ±22.5 (or 25) kHz deviation. Adjust output for indication of approx 2 on panel meter.	Center of 90 MHz calibration mark on dial.	AC VTVM to RCDR OUT FRONT L jack.	L405, L404, L403, and Z401 for max on VTVM. Reduce generator output to keep panel meter at approx 2.
12.	Set to 106 MHz.	Center of 106 MHz calibration mark on dial.	"	C418, C416, C411, and C402 for max on VTVM. Reduce generator output to keep panel meter at approx 3. Repeat steps 11 and 12 for max signal and accurate dial calibration.
13. METER FULL-SCALE	Position of non-interference near 98 MHz, no sweep, 100 mV output.	Tune to generator	Front panel meter	R705 FULL SCALE METER DEFLECTION ADJUST for 4.5 indication.
14. MUTING	"	"	Scope vert input to RCDR OUT FRONT L jack	Reduce generator output for noise visible on sine wave. Readjust generator frequency to center noise on positive and negative half cycles. See SYMMETRICAL TUNING response. Release MUTING OFF pushbutton.
15.	20 uV output.	"	"	Adjust R703 MUTING THRESHOLD ADJUST CCW until audio disappears on scope trace, then back off R703 slowly CW until audio reappears.
16.	Reduce output to 15 uV	"	"	Audio should disappear. Depress MUTING OFF, audio should reappear.
17. AFC PULL-IN	98 MHz, no sweep, adjust output for panel meter indication of 4.5.	Tune to generator	Front panel meter	Detune receiver above 98 MHz for panel meter reading of approx 2.5. Depress AFC. Receiver should 'pull-in' for reading of 4 min. Release AFC and repeat test, tuning receiver below 98 MHz.

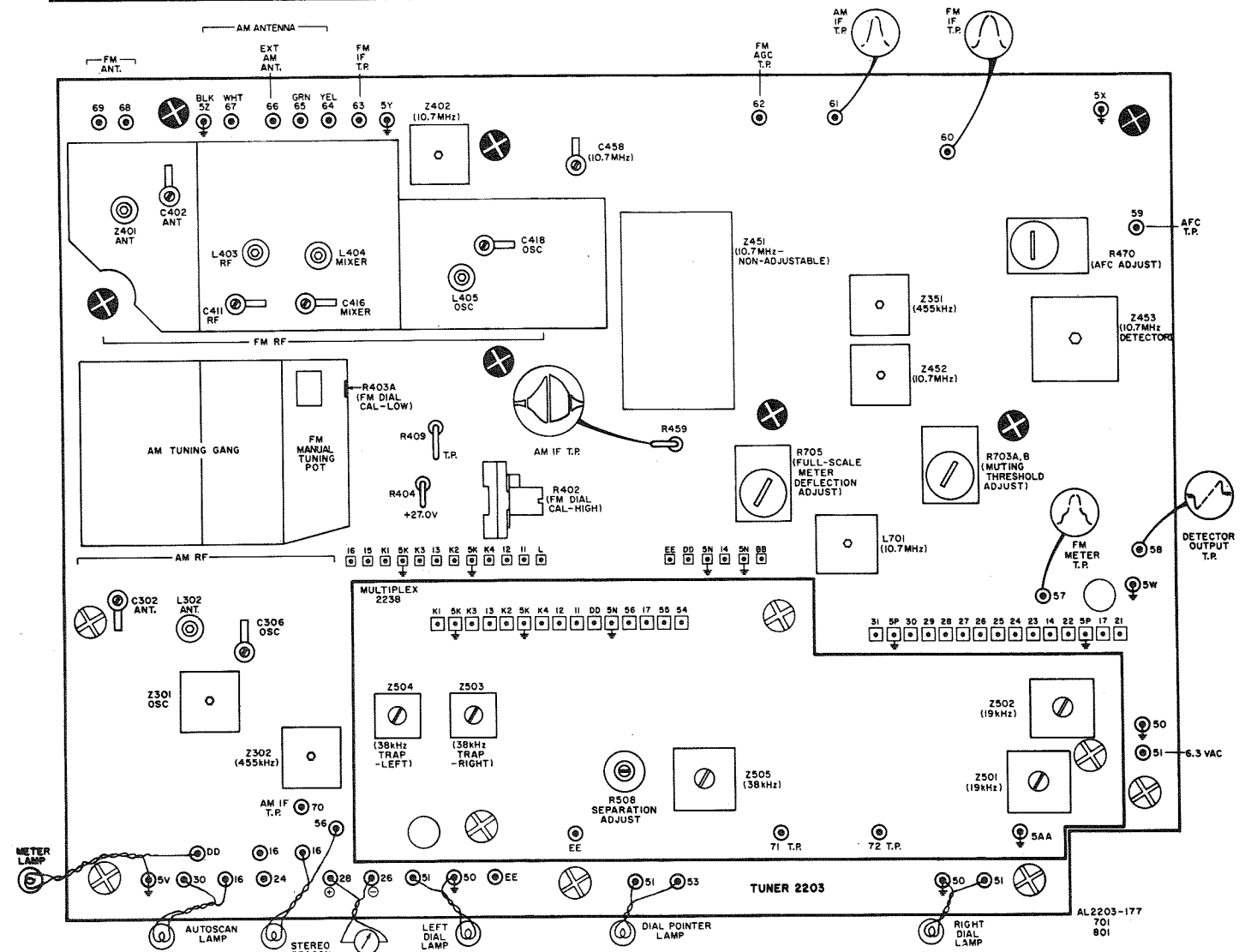

NOTE: CHASSIS GROUNDS ARE COMPLETED THROUGH MOUNTING SCREWS (S). TIGHTEN BEFORE ATTEMPTING ALIGNMENT OR TEST.

FM IF

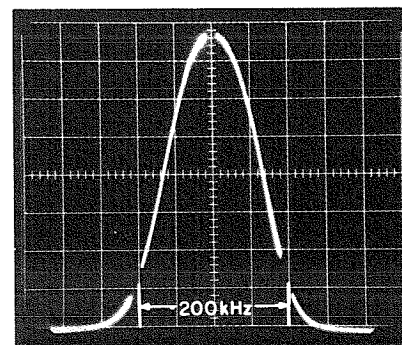

FM IF-LIMITED

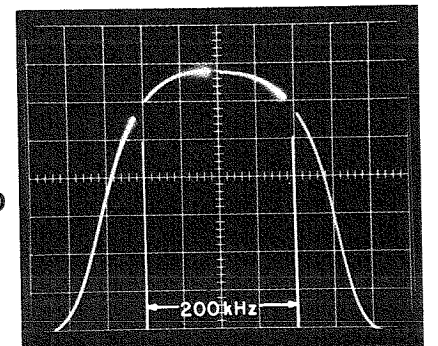

FM DETECTOR

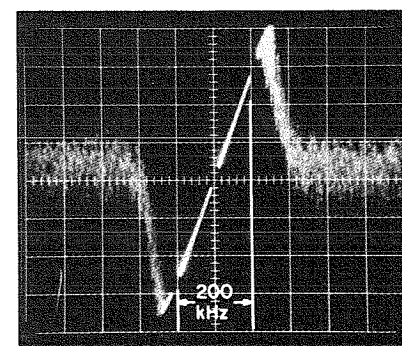

SYMMETRICAL TUNING

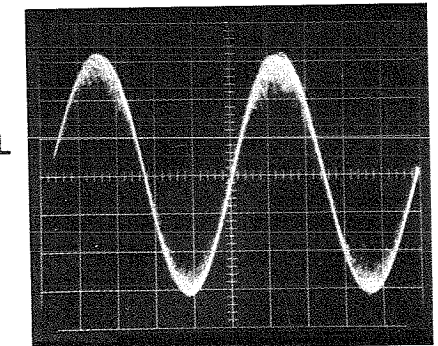

STEP	GENERATOR	DIAL SETTING	INDICATOR	ADJUSTMENT	
NOTE: Set MODE to STEREO, depress AFC.					
18.	19kHz PILOT	FM generator with composite multiplex signal at EXTERNAL MODULATION input. Modulate with 19 kHz pilot (10%), 400 Hz audio (90%) left channel only. Set for ± 25 kHz deviation and 2 mV output.	"	DC VTVM to pin 72, gnd to 5AA	Z501 and Z502 for max on VTVM (0.7 VDC min). Set generator for ± 42.5 kHz deviation. VTVM should indicate 1.7 VDC, min., STEREO-BEACON lamp should light.
19.	SEPARATION	"	"	AC VTVM to RCDR OUT FRONT L jack, another to RCDR OUT FRONT R jack	Set R508 SEPARATION ADJUST to mid-range. Adjust Z505 and R508 for min on right channel (at least 36 dB below left channel). Modulate right channel only. If necessary readjust Z505 and R508 for left channel indication 36 dB below right channel.
20.	STEREO-BEACON	Reduce output to 15 μ V	"	STEREOBEACON lamp	STEREOBEACON should be off. Increase generator output to 35 μ V, lamp should go on. (No adjustment)
21.	38 kHz TRAP	Modulate with 19 kHz pilot, ± 7.5 kHz deviation (no audio). Set to 2mV output.	"	HD analyzer to RCDR OUT FRONT R jack.	Tune out 19 kHz fundamental to measure distortion. Adjust Z503 for min distortion reading.
22.	"	"	"	HD analyzer to RCDR OUT FRONT L jack.	Adjust Z504 per step 21.

AUTOSCAN ADJUSTMENT — SELECTOR to FM, MODE to STEREO, AUTOSCAN MODE depressed, all others released, FRONT and REAR VOLUME to 0.

STEP	GENERATOR	DIAL SETTING	INDICATOR	ADJUSTMENT	
NOTE: Check FM ALIGNMENT (IF, RF, Detector, MPX) before adjusting autoscan.					
1.	AUTO-SCAN	FM generator to FM ANTenna terminals, through series 120-ohm composition resistors. Set to 88 MHz. Modulate with 400 Hz, ± 25 kHz deviation. Adjust output for 10 mV.	Tune to generator by pressing CONTINUOUS or ONE STATION push-button.	DC VTVM to pin 34, gnd to 5P. Use lowest (most sensitive) range.	R906 HOLD CONTROL for -30 mV.
2.	108.5 MHz	"	Front panel AUTOSCAN meter.	R908 HIGH LIMIT for scan reset.	
3.	108 MHz	"	"	Repeat step 2 if necessary.	
4.	88 MHz. Reduce output to 3 μ V.	"	DC VTVM to pin 34, gnd to 5P.	-30 mV after 5 seconds.	
5.	108 MHz	"	"	200 mV max after 5 seconds.	
6.	REMOTE CONTROL	Connect RK-40 Remote Control. Connect antenna to FM ANTenna terminals.	Tune to stations using ADVANCE pushbuttons.	Front panel AUTOSCAN meter.	
7.	WIRELESS REMOTE CONTROL		Direct transmitter at receiver. Tune to stations using push-button.	"	

AM ALIGNMENT — SELECTOR to AM, MODE to MONO, FRONT and REAR VOLUME to 0.

Maintain generator output as low as possible for suitable indication.

STEP	GENERATOR	DIAL SETTING	INDICATOR	ADJUSTMENT	
1.	IF	455 kHz sweep generator to pin 70, gnd to 5V. Use 0.1 μ F capacitor in series with generator lead.	Position of non-interference.	Scope to junction of R459 and C353, gnd to 5V. Use low capacitance probe.	Detune Z351 primary (bottom) CW. Adjust Z302 for max gain.
2.	"	"	"	Scope to pin 61, gnd to 5V.	Z351 top and bottom for max gain and symmetry. Max response may be ± 2.5 kHz from center frequency. See AM IF response.
3.	FRONT END	AM generator to EXT AM ANT and GND term. Open EXT AM ANT GND link. Use 220 pF capacitor in series with generator lead. Set to 600 kHz. Modulate with 400 Hz, 30% modulation.	Center of 600 kHz calibration mark dial.	AC VTVM to RCDR OUT FRONT L jack.	Z301 and Z302 for max gain.
4.	1400 kHz		Center of 1400 kHz calibration mark on dial.	"	C306 and C302 for max gain. Repeat steps 3 and 4.

AM IF

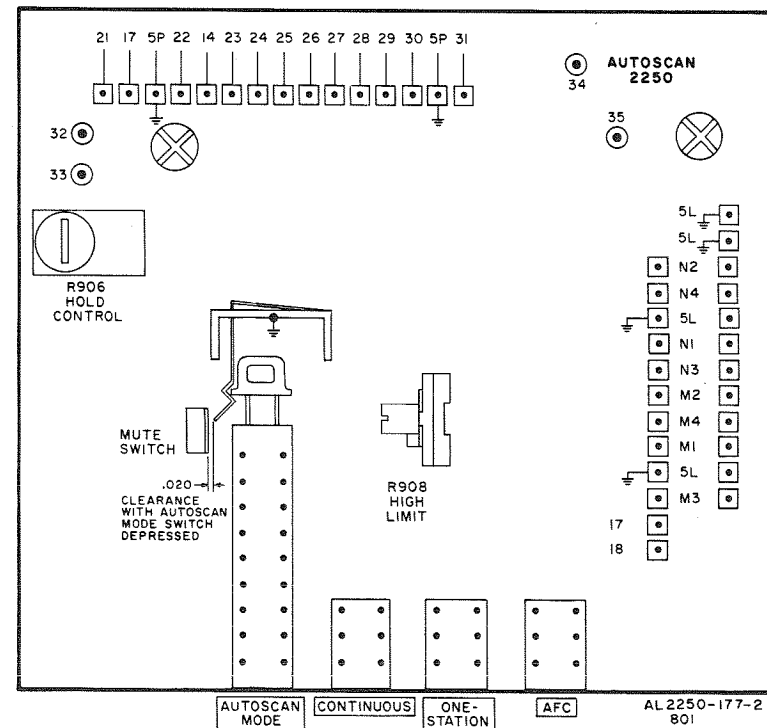
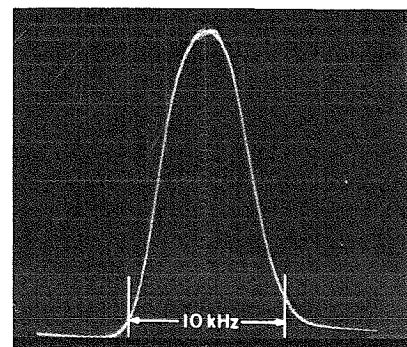

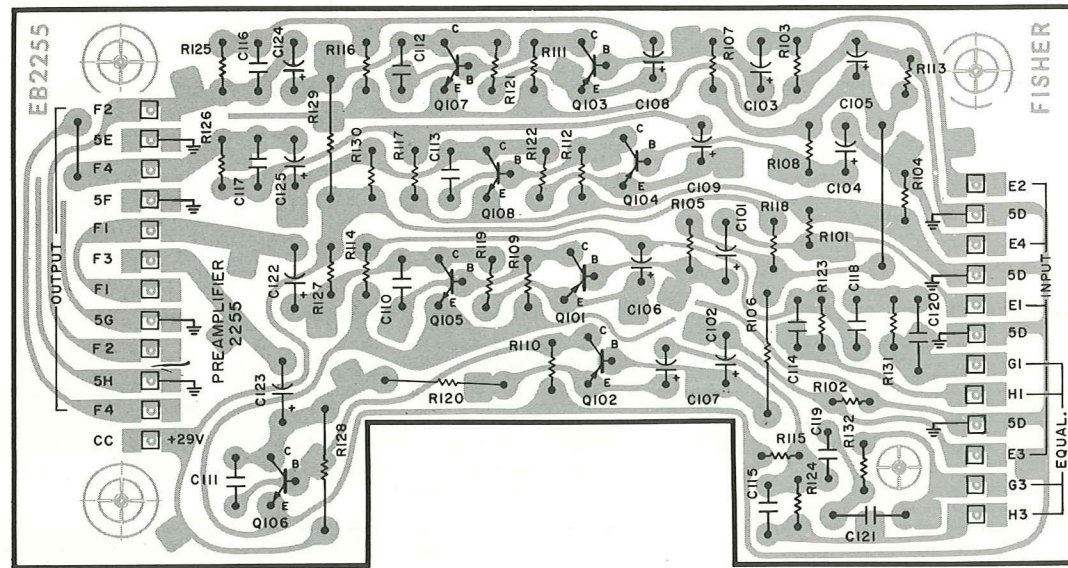

AL2255-111A

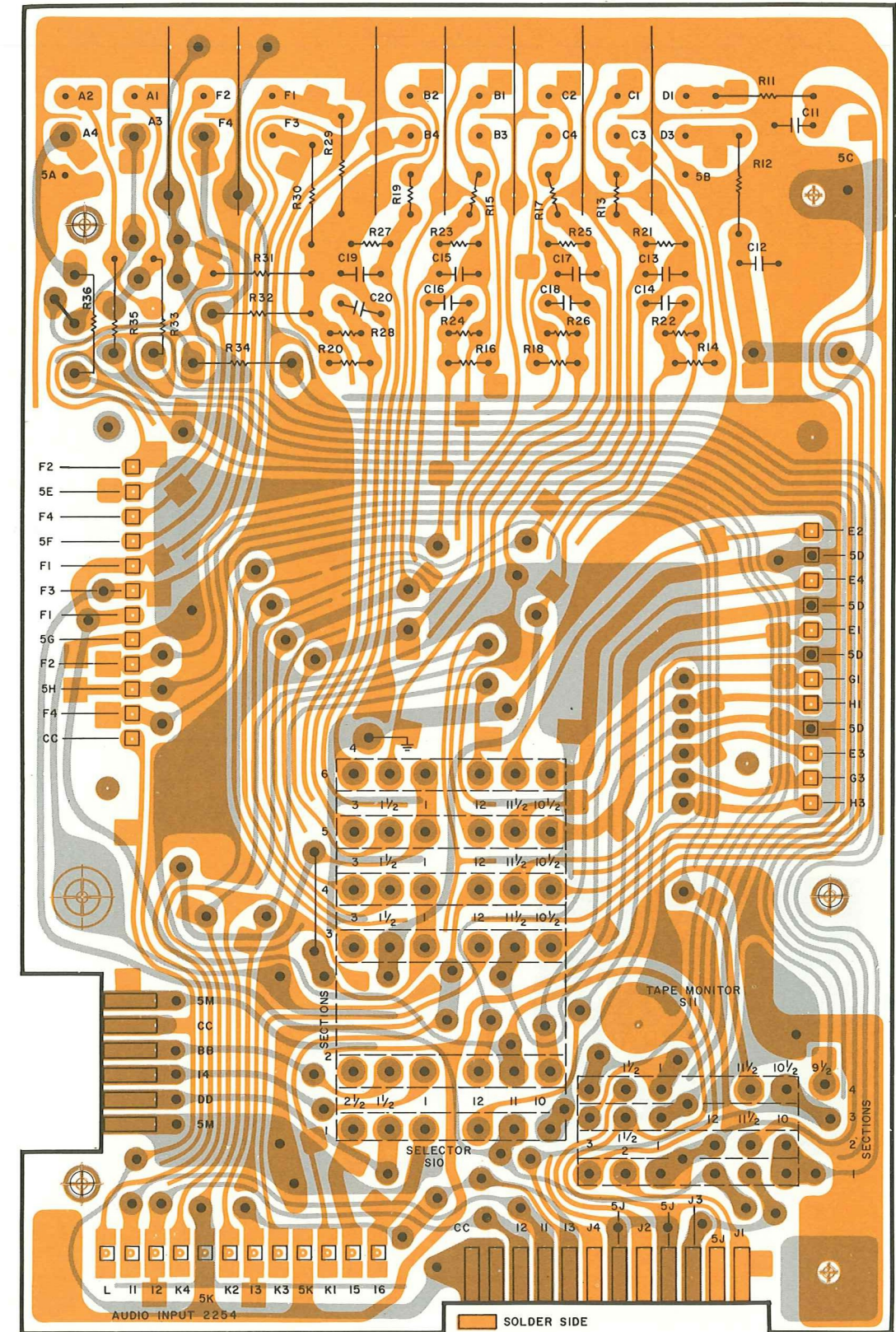

SOLDER SIDE
 COMPONENT SIDE

AL2254-114A

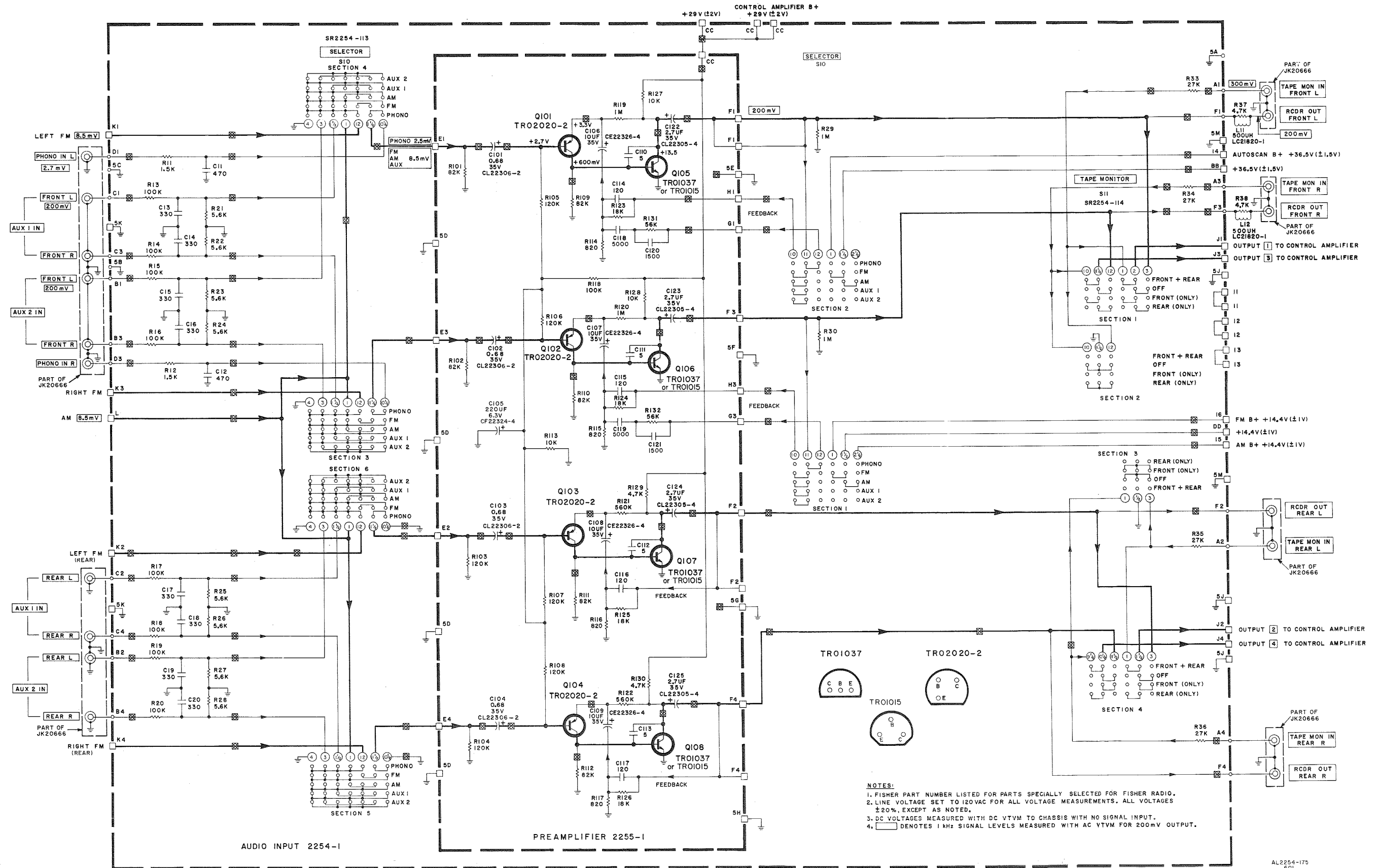

NOTES:
 1. FISHER PART NUMBER LISTED FOR PARTS SPECIALLY SELECTED FOR FISHER RADIO.
 2. LINE VOLTAGE SET TO 120VAC FOR ALL VOLTAGE MEASUREMENTS. ALL VOLTAGES $\pm 20\%$, EXCEPT AS NOTED.
 3. DC VOLTAGES MEASURED WITH DC VTVM TO CHASSIS WITH NO SIGNAL INPUT.
 4. \square DENOTES 1 kHz SIGNAL LEVELS MEASURED WITH AC VTVM FOR 200mV OUTPUT.

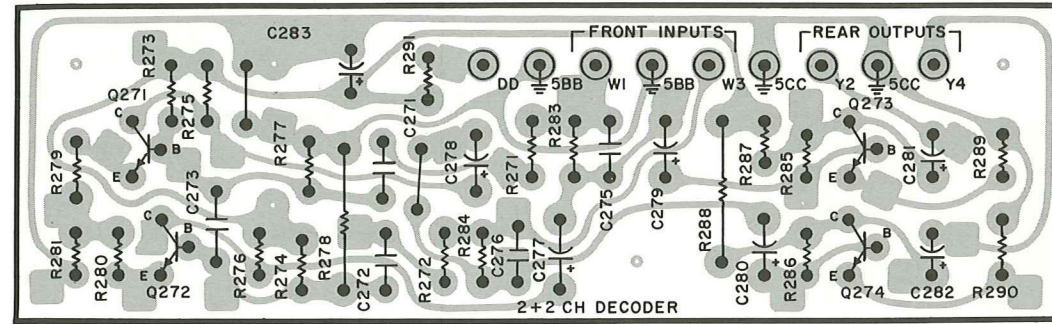

AL2289-III

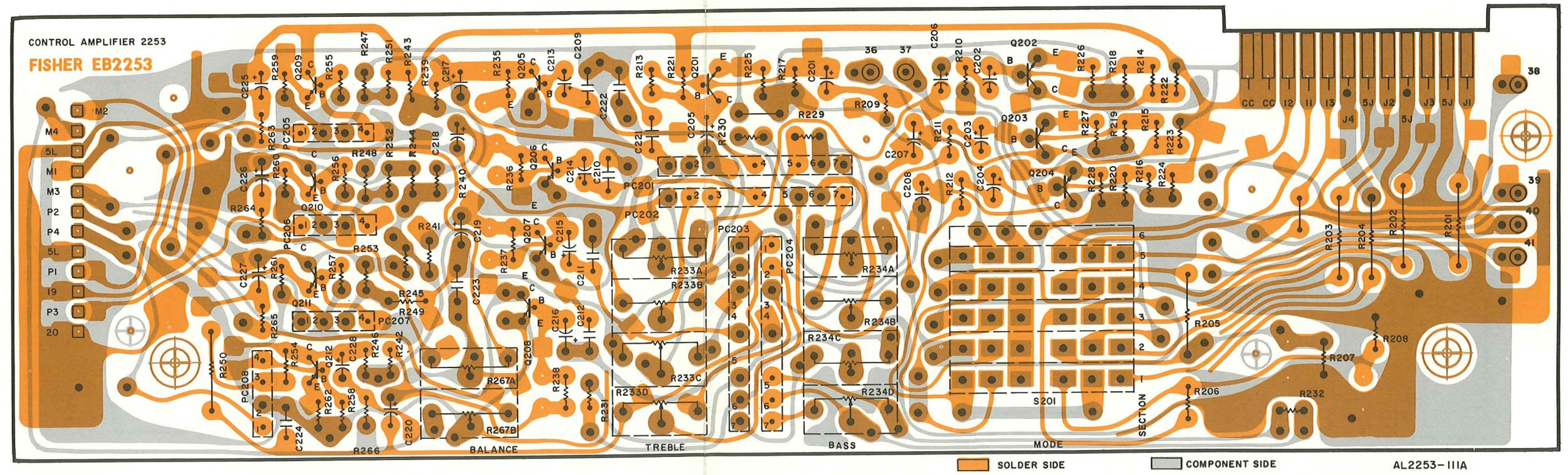
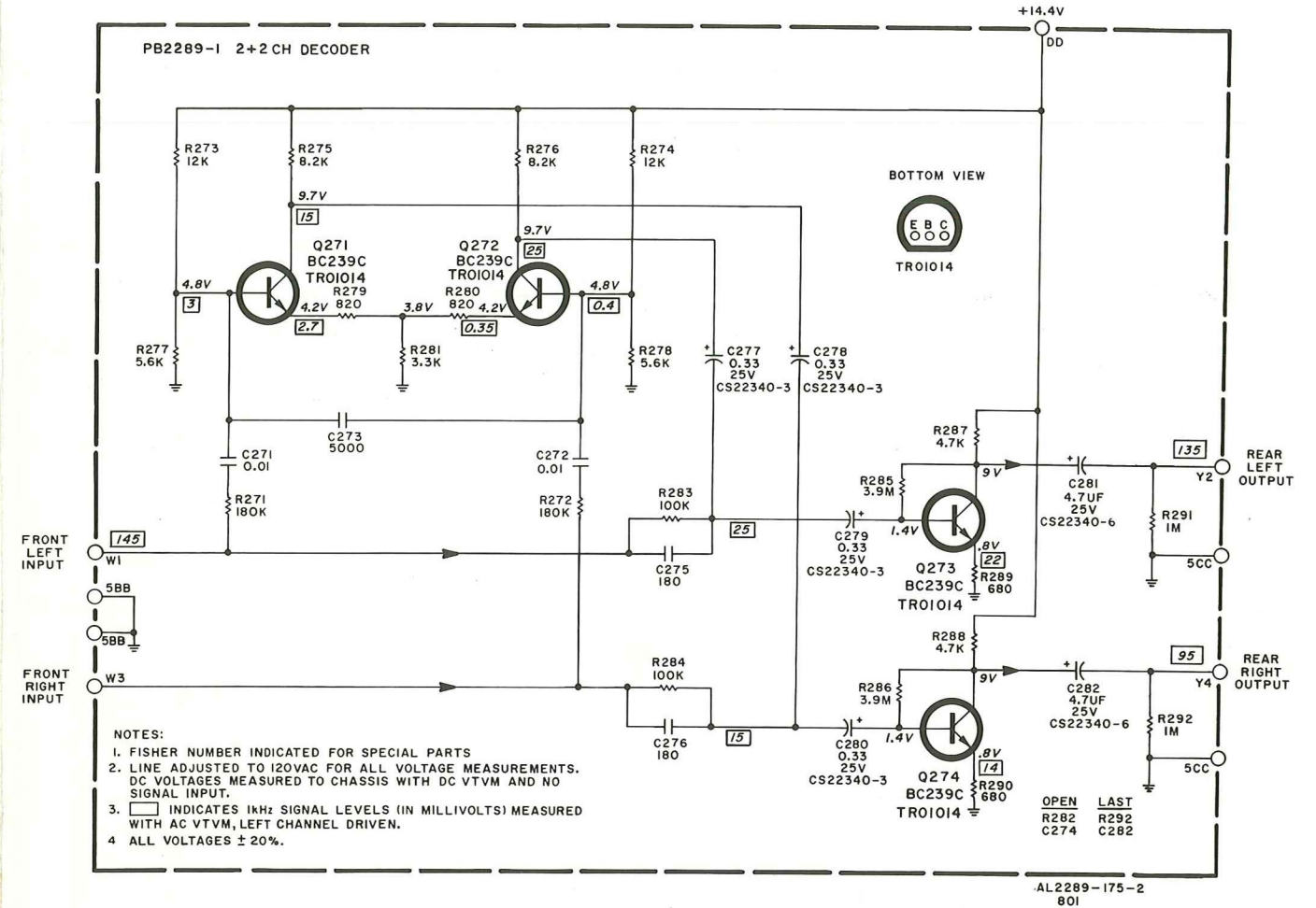

AL2253-111A

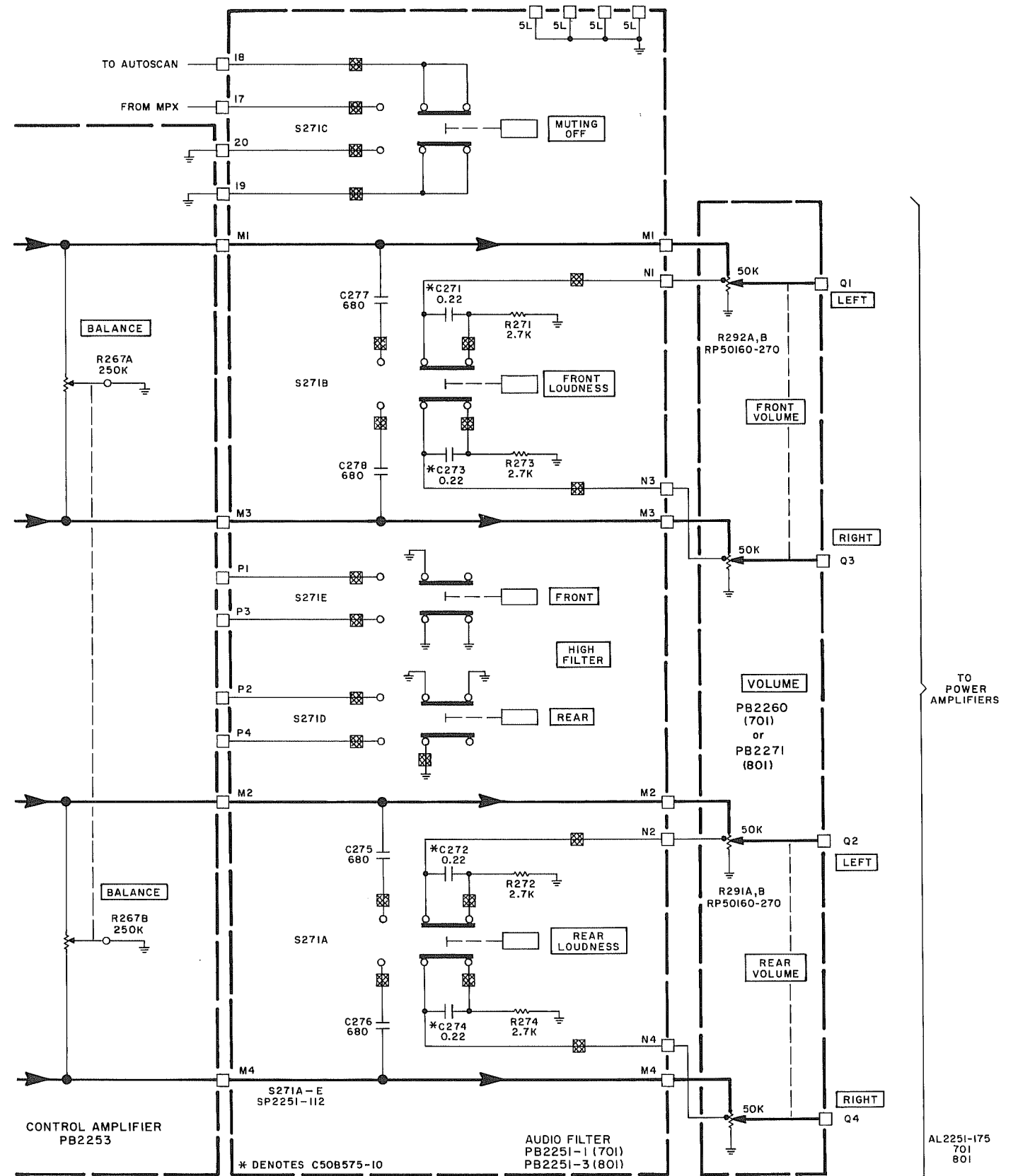
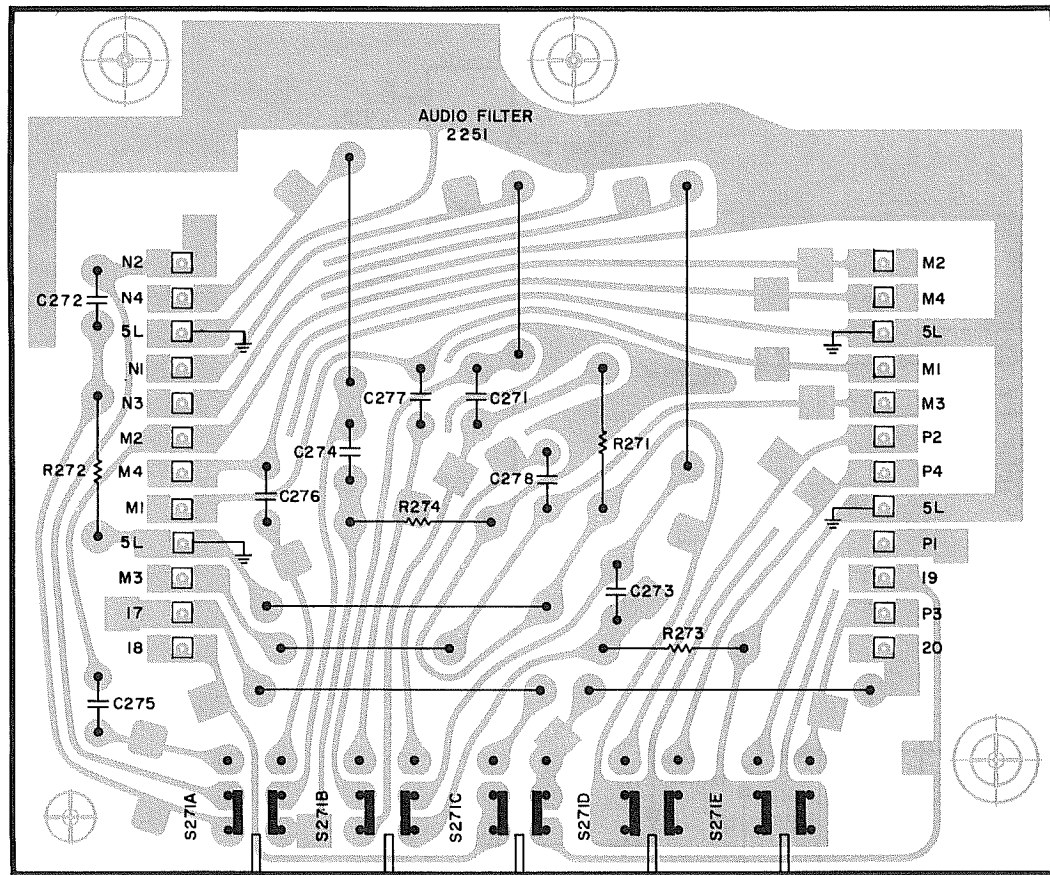

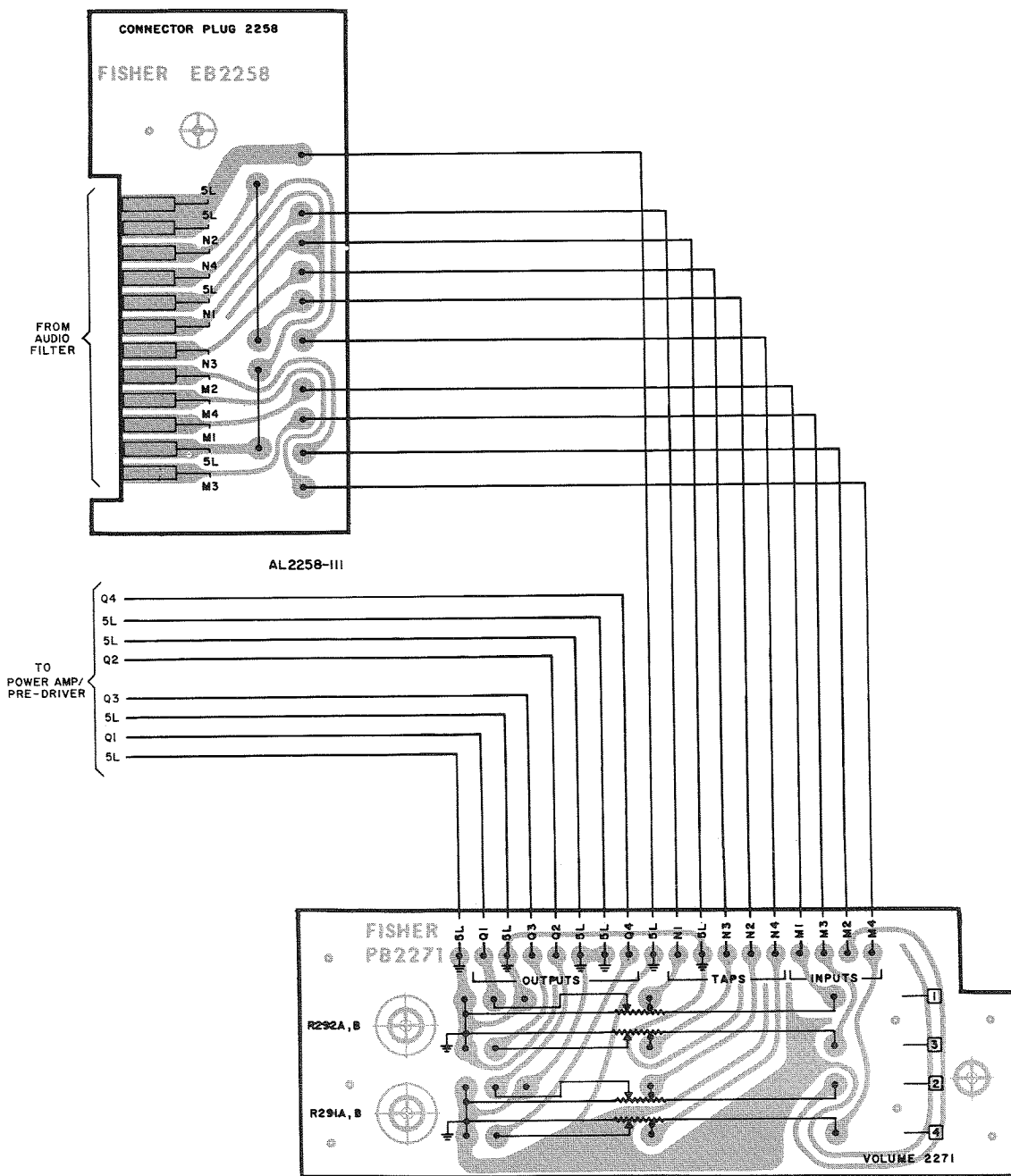

AL2271-III

CENTER VOLTAGE TEST

Slide FRONT and REAR VOLUME controls to 0. Warm-up unit about 10 minutes. Set line voltage to 120 VAC.

Connect common lead of DC VTVM to chassis ground. Connect probe to each emitter terminal of Q811 and Q812 on rear and front amplifiers. Meter should indicate +28V (±3V) at each emitter. See illustration.

IDLING CURRENT ADJUSTMENT

Slide FRONT and REAR VOLUME controls to 0. Warm-up unit about 10 minutes. Set line voltage to 120 VAC.

REAR AMPLIFIERS

(1) Connect common lead of DC VTVM to emitter terminal of Q813 and probe to emitter terminal of Q811. See illustration. Set IDLING ADJUST R821 for indication of 35 to 45 mV.

(2) Connect DC VTVM between emitters of Q812 and Q814 and adjust R822 for indication of 35 to 45 mV.

FRONT AMPLIFIERS

Repeat steps (1) and (2).

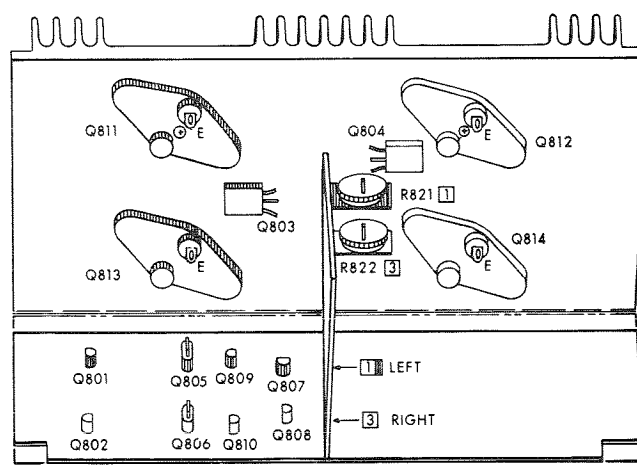
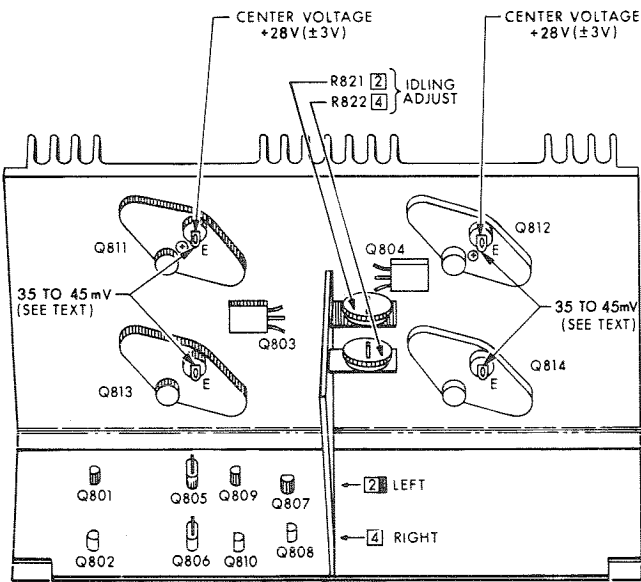
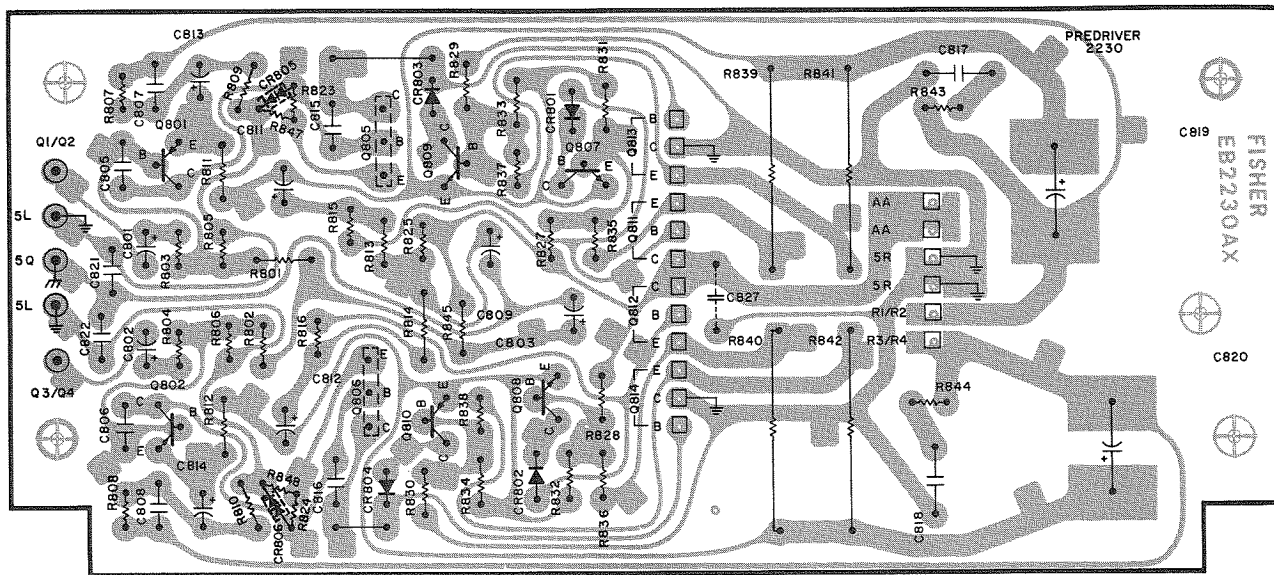
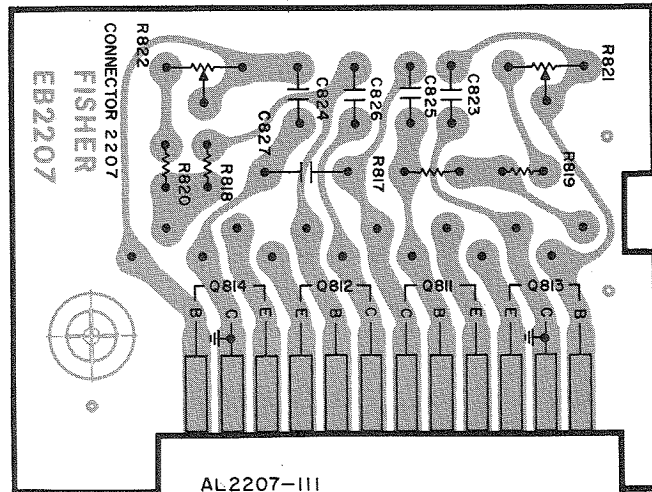

REAR AMPLIFIERS

FRONT AMPLIFIERS (SAME AS REAR)

AL2150-177-2 801

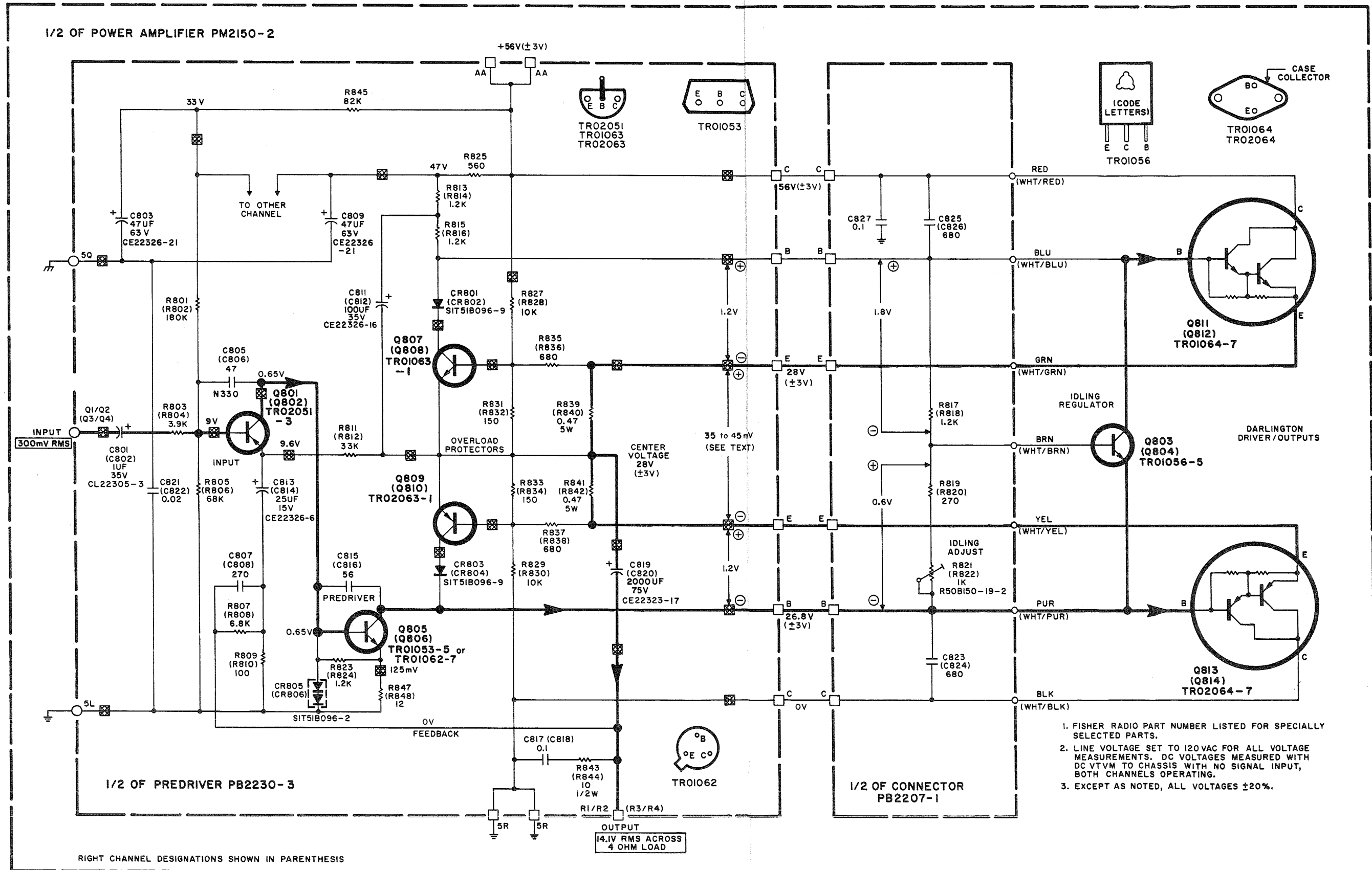

PARTS LIST

PLEASE READ CAREFULLY: This parts list is solely for the use of authorized Fisher service personnel, factory service stations, and franchised Fisher dealers. Prices do not include shipping charges. Please include the serial number of the Fisher equipment for which the part(s) are intended. Send your order to

PARTS DEPARTMENT, FISHER RADIO, 11-40 45th Road, Long Island City, N.Y. 11101.

MAIN CHASSIS

Symbol	Description	Part No.	Sug. Ret.
---	Antenna, Ferrite (AM)	LA51353	5.15
---	Antenna, FM Dipole	LA51319-1	1.45
---	Bracket, Antenna	AB4039-120	.80
---	Cabinet	KK4040-125-1	35.50
---	Channel Rubber	A670-137	.40
---	Coupling, Extender Shaft	H50A799	.35
---	Cover, Bottom	AA4072-114	8.95
---	Dial Glass, Screened	AS4039-107	.60
---	Dial Pointer Assy	AS20503-1	2.25
---	Dress Panel Assy	AS4072-120	28.00
---	Drum, Dial Cord	E51D156	.70
---	Foot, Plastic	E51A172	.30
---	Fuse: *2A, 250V, Sio-Blo	F51B247-18	.60
---	*4A, 250V, Sio-Blo	F51B247-22	.60
---	4A, 125V, Sio-Blo (UL Approved)	FL51313-12	.60
---	Jack, Headphone	JK20627-5	1.20
---	Knob: Volume	EK20029	.50
---	Pushbutton	EK20030	.50
---	Tuning Selector, Speakers, Mode, Tape Monitor	EK20035	.50
---	Dual Outer: Bass, Treble, Balance	EK20036	.50
---	Dual Inner: Bass, Treble, Balance	EK20037	.50
---	Lamp Assy, Pointer	EK20038	.70
---	Lamp Assy, Dial Glass (right)	AS21417-1	1.00
---	Lamp Assy, Dial Glass (left)	AS21410-7	.85
---	Lamp Assy, Dial Glass (left)	AS21410-6	.85
---	Lampholder Assy, Indicators	AS21414-1	3.45
---	Meter Clip	HH4039-129	.55
---	Meter, Indicating	MC21612	7.00
---	Nameplate '801'	NP22637	1.10
---	PCB AM-FM Tuner	PB2203-2	136.85
---	PCB MPX Decoder	PB2238-1	36.70
---	*PCB MPX Decoder	PB2238-2	37.50
---	PCB Autoscanner	PB2250-4	38.15
---	PCB Audio Input	PB2254-1	59.30
---	PCB Preamplifier	PB2255-1	30.10
---	PCB Control Amplifier	PB2253-2	66.40
---	PCB Audio Filter	PB2251-3	16.75
---	PCB 2+2 Channel Decoder	PB2289-1	13.95
---	PCB Connector-Volume (Combined PB2258-PB2271)	PB2209-1	18.40
---	Power Amplifier Module	PM2150-2	134.00
---	PCB Pre-driver, Driver	PB2230-3	51.45
---	PCB Connector	PB2207-1	3.70
---	PCB Vertical Connector	PB2257-1	6.50
---	PCB Remote Pickup	PB2244-1	18.95
---	Remote Control Transmitter	PX4079-1	14.95
---	PCB Transmitter (Combined EB2243/EB2248)	PB2249-1	9.50
---	PCB Power Supply	PB2267-1	59.75
---	*PCB Power Supply	PB2267-2	62.50
---	Receptacle, AC Outlet	JK20665	.60
---	Retainer, Dial Glass	AB4039-130	.65
---	*Switch, Voltage Selector	SR51304-1	1.65
---	Terminal Board, Speakers	ET51340-1	4.75
---	Terminal Strip, Antenna	ET51329	.29
---	Tuning Shaft Assy.	AS20722-3	2.85
L400	Choke, RF, 3.3 uH	LC21814-2	.55
R330	Resistor, Composition, 330K, 10%, 1/2W	RC20BF334K	.30
T1	Transformer, Power	TD4072-115	32.30
T1	*Transformer, Power	TE4072-215	38.65

*Used in Export Units Only

PB2203-2 AM-FM TUNER

Symbol	Description	Part No.	Sug. Ret.
C301	Ceramic, 1pF ±.25pF, 500V, P100	C50B652-20	.35
C302,306	Trimmer, 1 - 10pF	C50B938-2	.75
C303,427, 463,705	Ceramic, 39pF, 5%, 500V, N330	C50B652-51	.35
C304A,B	Ceramic, 4pF ±.25pF, 500V, NPO	C50B652-29	.35
C305	Polystyrene, 382pF, 1%, 33V	C51B256-36	.90
C307	Ceramic, 5pF, 5%, 500V N1500	C50B652-47	.35
C308	Ceramic, 15pF, 5%, 500V, N750	C50B652-46	.35
C309	Ceramic, 270pF, 10%, 500V	C50B651-18	.30
C310	Ceramic, 180pF, 10%, 500V	C50B651-14	.30
C311	Electrolytic, 47uF, 16V	CE22326-9	.70
C312,313, 315,457, 460,703	Ceramic, 0.02uF, +80-20%, 100V	C50B570-2	.45
C314	Polyester, 0.1uF, 10%, 160V	C50B646-4	.45
C316	Polystyrene, 1200pF, 5%, 33V	C51B256-32	.50
C317	Polyester, 0.022uF, 10%, 160V	C50B647-9	.45
C351	Silvered Mica, 330pF, 5%, 50V	CA22313-6	.40
C352	Polystyrene, 750pF, 5%, 33V	C51B256-12	.50
C353	Silvered Mica, 390pF, 5%, 50V	CA22313-18	.40
C354,355	Polystyrene, 4700pF, 5%, 33V	C51B256-23	.50
C357,401, 405,408, 409,410, 417,421, 422,423, 425,455, 475,476, 707,708	Ceramic, 1000pF, 10%, 500V	C50B651-3	.35
C358,359	Electrolytic, 4uF, 35V	CE22326-1	.50
C360	Ceramic, 0.02uF, 20%, 500V	C50B567-3	.35
C361	Ceramic, 1800pF, 10%, 500V	C50B651-22	.35
C402,406, 411	Trimmer, 1-6pF	C50B938-5	.75
C404,472, 473	Electrolytic, 10uF, 35V	CE22326-4	.65
C406,407, 412,419, 424,451, 454,461, 464,465, 466,467, 468,469, 470,471, 479,701, 704,706, 709,711, 712	Ceramic, 0.01uF, +80-20%, 100V	C50B570-1	.40
C413	Ceramic, 12pF, 5%, 500V, NPO	C50B652-34	.35
C415	Ceramic, 8pF, 5%, 500V, NPO	C50B652-24	.35
C418	Trimmer, 0.5 - 3pF	C50B938-8	1.20
C420	Ceramic, Tubular, 4pF ±.25pF, 500V, N470	CT22336-5	.50
C426,477	Polyester, 0.33uF, 10%, 160V	C50B646-7	.65
C452	Tantalum, 4.7uF, 25V	CL22305-6	.90
C453,459	Ceramic, 0.1uF, +80-20%, 12V	CK22315-2	.45

PARTS LIST

PB2203-2 AM-FM TUNER

Symbol	Description	Part No.	Sug. Ret.
C456,478	Ceramic, 5 pF, 5%, 500V, NPO	C50B652-21	.35
*C456	Ceramic, 7pF, 10%, 500V, N470	C50B652-35	.35
C462	Polystyrene, 560pF, 5%, 33V	C51B256-10	.50
C474	Ceramic, 10pF, 10%, 500V, NPO	C50B652-28	.30
C702	Ceramic, 5000pF, 20%, 500V	C50B567-2	.30
C713	Tantalum, 1uF, 35V	CL22305-3	.80
CF351, 352	Ceramic Filter	ZK22106	2.00
CR351, 352,451, 702	Diode, Germanium, AA119	TR12001-4	.60
CR405	Diode, Varicap BB104 (White)	TR17001-6	1.45
CR406	Diode, Varicap BB104 (Green)	TR17001-1	.85
CR701	Diode, Silicon	TR13006-2	.35
IC451	IC Single Stage IF Amplifier	TR09008	2.30
IC452, 701	IC Two-Stage IF Ampl/AGC	TR09010	4.25
IC453	IC Four-Stage IF Amplifier	TR09007	4.35
L301,401, 402,451 452,702	RF Choke, 3.3uH	LC21814-2	.55
L302	Coil, Adjustable	LC21823	1.10
L403	RF Coil	L21B810	.75
L404	Mixer Coil	L21B811	.75
L405	Oscillator Coil	LC21816	.90
L701	IF Transformer, 10.7MHz	ZZ50210-165	1.15
PC351	Printed Circuit	EP50187-81	1.25
PC451	Printed Circuit	EP50187-76	2.40
PC452	Printed Circuit	EP50187-80	2.10
Q301,302	Transistor A494/BF194	TR01027	1.00
Q351,451, 452,701, 703	Transistor BC147B	TRBC147B	.55
Q401	Transistor, Dual Gate, MOSFET	TR08003	1.75
Q402	Transistor, PNP, Silicon	TR02012	1.00
Q403	Transistor, N-Channel FET	TR06011	1.55
Q702	Transistor, PNP, Silicon	TR02020-2	.55
R403A,B	Part of AM Variable, C304A,B		
R404,710, 713	12K	R33DC271J	.30
R405	100	R33DC101J	.30
R406	8.2K	R33DC822J	.30
R407,418, 419	Composition, 150K, 1/4W, 10%	RC07BF154K	.30
R409	10M	R33DC106J	.30
R411,422, 465	220	R33DC221J	.30
R412	Composition, 1.2K, 1/4W, 5%	RC07BF122J	.30
R413	Composition, 150, 1/4W, 5%	RC07BF151J	.30
R414	Composition, 15K, 1/4W, 5%	RC07BF153J	.30
R415	Composition, 1.5K, 1/4W, 5%	RC07BF152J	.30
R420,474	47K	R33DC473J	.30
R423	470K	R33DC474J	.30
R451,708	15K	R33DC153J	.30
R452	33K	R33DC333J	.30
R459	27K	R33DC273J	.30
R461	330	R33DC331J	.30
R467	220K	R33DC224J	.30
R468	56K	R33DC563J	.30
R470	Variable Resistor	RV50150-22-1	1.25
R472	12	R33DC120J	.30
R473	Composition, 10, 1/2W, 10%	RC20BF100K	.30
R701	560	R33DC561J	.30
R703A,B	Variable Resistor	RV50150-22-2	1.20
*R703	Variable, 5K, ±30%	R50B150-20-3	1.10
R705	Variable, 2.5K, ±30%	R50B150-20-11	.70
R301,400, 469	2.2K	R33DC222J	.30
R302,465	120	R33DC121J	.30
R303,702	680	R33DC681J	.30
R304,408	3.9K	R33DC392J	.30
R305,453, 466,714	1K	R33DC102J	.30

PB2203-2 AM-FM TUNER

Symbol	Description	Part No.	Sug. Ret.
*R453	820	R33DC821J	.30
R306,312, 417,711, 715	4.7K	R33DC472J	.30
R307,309	6.8K	R33DC682J	.30
R308	47	R33DC470J	.30
R310,359, 421,455, 706	100K	R33DC104J	.30
R311	10	R33DC100J	.30
R313,360, 460,704	10K	R33DC103J	.30
R351,356, 456,712	3.3K	R33DC332J	.30
R352	100	R33DC101J	.30
R353	330K	R33DC334J	.30
R355,358, 709	2.7K	R33DC272J	.30
R357	22K	R33DC223J	.30
R401,410, 416,454, 462,471, 475,707	150K	R33DC154J	.30
R402	Trimmer Pot., 5K ±30%	R50150-52	.80
Z301	AM Oscillator Coil	ZZ50210-141	1.60
Z302	Transformer, 455kHz, IF Output	ZZ50210-167	1.50
Z351	Transformer, 455kHz, AM IF Out	ZZ50210-162	2.00
Z401	FM Antenna Coil	L21B808	1.45
Z402	IF Transformer, 10.7MHz	ZZ50210-164	1.50
Z451	Torroidal Filter	ZZ50210-168	17.10
*Z451	Torroidal Filter	ZZ50210-172	4.95
Z452	IF Transformer, 10.7MHz	ZZ50210-163	1.65
Z453	Ratio Detector, 10.7MHz	ZZ50210-150	3.70

*Used in some tuners

PB2250-4 AUTOSCAN

Symbol	Description	Part No.	Sug. Ret.
C901	Ceramic, 0.05uF, +80-20%, 100V	C50B572-1	.40
C902	Electrolytic, 200uF, 20%, 35V	CE22338-1	1.00
C903	Electrolytic, 47uF, 20%, 16V	CE22338-3	.75
C904	Mylar, 1.5uF, 10%, 100V	C50B575-9	1.60
CR901	Diode, Silicon	TR13006-2	.35
Q901	Transistor, N-Channel FET	TR06010	2.35
Q902	Transistor, Unijunction (SU61)	TR18001	2.30
Q903,906	Transistor, PNP (2N4250)	TR02020-2	.55
Q904,905	Transistor, BC147B	TRBC147B or TR01040	1.05
R901	100K	R33DC104J	.30
R902,912, 920	47K	R33DC473J	.30
R903	6.8K	R33DC682J	.30
R904,922	22K	R33DC223J	.30
R905	220	R33DC221J	.30
R906	Variable Resistor, 5K ±30%	R50B150-20-3	1.10
R907	100	R33DC101J	.30
R908	Trimmer Pot., 5K ±30%	R50150-52	1.65
R909	33	R33DC330J	.30
R910	1.5K	R33DC152J	.30
R911,915, 924	2.2K	R33DC222J	.30
R913	10K	R33DC103J	.30
R914	56K	R33DC563J	.30
R916	33K	R33DC333J	.30
R917	5.6K	R33DC562J	.30
R918	12K	R33DC123J	.30
R919	3.3K	R33DC332J	.30
R921	470	R33DC471J	.30
R923	22	R33DC220J	.30
R925	8.2K	R33DC822J	.30
S901A,B, C,D	4-Pushbutton Switch	SP2250-112	5.65

BECAUSE ITS PRODUCTS ARE SUBJECT TO CONTINUOUS IMPROVEMENT, FISHER RADIO RESERVES THE RIGHT TO MODIFY ANY DESIGN OR SPECIFICATION WITHOUT NOTICE AND WITHOUT INCURRING ANY OBLIGATION.

PRICES SUBJECT TO CHANGE WITHOUT NOTICE

NOTE: Unless otherwise specified, all resistors are Deposited Carbon Film in ohms, 5%, 1/3 Watt. K = Kilohms, M = Megohms

PB2238-1, -2 MPX DECODER

Symbol	Description	Part No.	Sug. Ret.
C501,511	Electrolytic, 4uF, 35V	CE22326-1	.65
C502	Ceramic, 0.01uF, +80-20%, 100V	C50B570-1	.40
C503,512, 516,517	Electrolytic, 1uF, 70V	CE22326-2	.65
C504	Silvered Mica, 200pF, 5%, 50V	CA22313-15	.40
C505	Ceramic, 180pF, 10%, 500V	C50B651-14	.30
C506,510	Polystyrene, 4700pF, 5%, 33V	C51B256-23	.50
C507,508	Electrolytic, 100uF, 16V	CE22326-12	.70
C509,515	Electrolytic, 25uF, 15V	CE22326-6	.65
C513,514	Polyester, 0.015uF, 5%, 160V	C50B647-17	.50
*C513,514	Polyester, 0.01uF, 5%, 160V	C50B647-18	.50
C518,519	Ceramic, 330pF, 10%, 500V	C50B651-1	.30
C520,523, 524	Ceramic, 1000pF, 10%, 500V	C50B651-3	.35
C521,522	Silvered Mica, 330pF, 1%, 50V	CA22313-31	.50
C525	Polystyrene, 3900pF, 5%, 33V	C51B256-22	.50
C526	Ceramic, 500pF, 5%, 500V, N1500	C50B652-50	.45
CR501, 502	Diode, Silicon	TR13006-2	.35
IC501	IC MPX Decoder	TR09011	7.70
PC501	Printed Circuit	EP50187-82	2.70
Q501,502	Transistor BC147B	TRBC147B	1.05
R501	8.2K	R33DC822J	.30
R502	220	R33DC221J	.30
R503	3.3K	R33DC332J	.30
R504,505	15K	R33DC153J	.30
R506	68K	R33DC683J	.30
R507,515	4.7K	R33DC472J	.30
R508	Trimmer, 200, ±20%	RV50150-23-1	.65
R509	270	R33DC271J	.30
R510	120	R33DC121J	.30
R511,512	5.6K	R33DC562J	.30
R513,514	22K	R33DC223J	.30
R516,517	10K	R33DC103J	.30
Z501,502	Coil, 19kHz	ZZ50210-170	1.10
Z503,504	Coil, 38kHz Trap	ZZ50210-169	.90
Z505	Coil, 38kHz	ZZ50210-166	1.10

*Used in PB2238-2 only

PB2254-1 AUDIO INPUT

Symbol	Description	Part No.	Sug. Ret.
C11,12	Ceramic, 470pF, 10%, 500V	C50B651-13	.30
C13,14,15, 16,17,18, 19,20	Ceramic, 330pF, 10%, 500V	C50B651-1	.35
L11,12	RF Choke, 500uH	LC21820-1	.60
R11,12	1.5K	R33DC152J	.30
R13,14,15, 16,17,18, 19,20	100K	R33DC104J	.30
R21,22,23, 24,25,26, 27,28	5.6K	R33DC562J	.30
R29,30	1M	R33DC105J	.30
R33,34,35, 36	27K	R33DC273J	.30
R37,38	4.7K, 1/8W	R12DC472J	.30
S10	Selector Switch	SR2254-113	13.00
S11	Tape Monitor Switch	SR2254-114	8.15

PB2255-1 PREAMPLIFIER

Symbol	Description	Part No.	Sug. Ret.
C101,102, 103,104	Tantalum, 0.68uF, 35V	CL22306-2	.75
C105	Electrolytic, 220uF, 6.3V	CF22324-4	.70
C106,107, 108,109	Electrolytic, 10uF, 35V	CE22326-4	.65
C110,111, 112,113	Ceramic, 5pF, 5%, 500V, NPO	C50B652-21	.35
C114,115, 116,117	Ceramic, 120pF, 10%, 500V	C50B651-16	.35
C118,119	Ceramic, 5000pF, 20%, 500V	C50B567-2	.30
C120,121	Ceramic, 1500pF, 10%, 1000V	C50B576-4	.45
C122,123, 124,125	Tantalum, 2.7uF, 35V	CL22305-4	.90
Q101,102, 103,104	Transistor, PNP	TR02020-2	.55
Q105,106, 107,108	Transistor, NPN	TR01037	1.00
R101,102, 109,110, 111,112	82K	R33DC823J	.30
R103,104, 105,106, 107,108	120K	R33DC124J	.30
R113,127, 128	10K	R33DC103J	.30
R114,115, 116,117	820	R33DC821J	.30
R118	100K	R33DC104J	.30
R119,120	1M	R33DC105J	.30
R121,122	560K	R33DC564J	.30
R123,124, 125,126	18K	R33DC183J	.30
R129,130	4.7K	R33DC472J	.30
R131,132	56K	R33DC563J	.30

PB2289-1 2+2 DECODER

Symbol	Description	Part No.	Sug. Ret.
C271,272	Mylar, 0.01uF, 5%, 100V	C50B574-1	.45
C273	Ceramic, 5000pF, 20%, 500V	C50B567-2	.30
C275,276	Ceramic, 180pF, 10%, 500V	C50B651-14	.50
C277,278, 279,280	Sintered Alum., 0.33uF, 20%, 25V	CS22340-3	.50
C281,282	Sintered Alum., 4.7uF, 20%, 25V	CS22340-6	.70
Q271,272, 273,274	Transistor BC239C	TR01014	.50
R271,272	Composition, 180K, 5%, 1/4W	RC07BF184J	.30
R273,274	Dep. Carb., 12K, 5%, 1/8W	R12DC123J	.30
R275,276	Composition, 8.2K, 5%, 1/4W	RC07BF822J	.30
R277,278	Dep. Carb., 5.6K, 5%, 1/8W	R12DC562J	.30
R279,280	Composition, 820, 5%, 1/4W	RC07BF821J	.30
R281	Composition, 3.3K, 5%, 1/4W	RC07BF332J	.30
R283,284	Composition, 100K, 5%, 1/4W	RC07BF104J	.30
R285,286	Composition, 3.9M, 5%, 1/4W	RC07BF395J	.30
R287,288	Composition, 4.7K, 5%, 1/4W	RC07BF472J	.30
R289,290	Composition, 680, 5%, 1/4W	RC07BF681J	.30

NOTE: Unless otherwise specified, all resistors are Deposited Carbon Film in ohms, 5%, 1/3 Watt.
K = Kilohms, M = Megohms

PB2253-2 CONTROL AMPLIFIER

Symbol	Description	Part No.	Sug. Ret.
C200	Ceramic, 3900pF, 10%, 500V	C51B189-17	.40
C201,202,203,204	Tantalum, 0.33uF, 35V	CL22305-9	.80
C205,206,207,208,213,214,215,216,225,226,227,228	Tantalum, 1uF, 35V	CL22305-3	.80
C209,210,211,212	Ceramic, 820pF, 10%, 500V	C50B651-6	.35
C217,218,219,220	Tantalum, 4uF, 35V	CL22305-14	.90
C221,222,223,224	Ceramic, 47pF, 10%, 500V, N330	C50B652-19	.30
PC201,202,203,204	Etched Circuit, Tone Control	PC50B187-57	1.60
PC205,206,207,208	Etched Circuit, High Filter	PC50B187-53	1.10
Q201,202,203,204	Transistor, NPN	TR01037 or TR01015	1.00
Q205,206,207,208,209,210,211,212	Transistor, NPN	TRBC147B	1.05
R201,202,203,204	22K	R33DC223J	.30
R209,210,211,212	47K	R33DC473J	.30
R213,214,215,216	220K	R33DC224J	.30
R217,218,219,220,255,256,257,258	27K	R33DC273J	.30
R221,222,223,224,239,240,241,242,243,244,245,246,263,264,265,266	4.7K	R33DC472J	.30
R225,226,227,228,259,260,261,262	180	R33DC181J	.30
R229,230,231,232	330K	R33DC334J	.30
R233A,B,C,D,234A,B,C,D	Bass and Treble Controls, 200K	RP50160-273	4.30
R235,236,237,238	820K	R33DC824J	.30
R247,248,249,250	100K	R33DC104J	.30
R251,252,253,254	270K	R33DC274J	.30
R267A,B	Balance Control, 250K	RP50160-271	2.80
S201	Mode Switch	SR2253-114	11.00

PB2251-3 AUDIO FILTER

Symbol	Description	Part No.	Sug. Ret.
C271,272,273,274	Mylar, 0.22uF, 10%, 250V	C50B575-10	.60
C275,276,277,278	Ceramic, 680pF, 10%, 500V	C50B651-2	.30
R271,272,273,274	2.7K	R33DC272J	.30
S271A,B,C,D,E	5-Pushbutton Switch	SP2251-112	6.15

PB2209-1 CONNECTOR-VOLUME
(Combined EB2258-EB2271)

Symbol	Description	Part No.	Sug. Ret.
R291A,B,292A,B	Dual Slide Volume Control, 50K	RP50160-270	5.85

PM2150-2 POWER AMPLIFIER MODULE
PB2230-3 PREDRIVER
PB2207-1 CONNECTOR

Symbol	Description	Part No.	Sug. Ret.
C801,802	Tantalum, 1uF, 20%, 35V	CL22305-3	.80
C803,809	Electrolytic, 47uF, 63V	CE22326-21	.75
C805,806	Ceramic, 47pF, 10%, 500V, N330	C50B652-19	.30
C807,808	Ceramic, 270pF, 10%, 100V	C50B651-18	.35
C811,812	Electrolytic, 100uF, 35V	CE22326-16	.75
C813,814	Electrolytic, 25uF, 15V	CE22317-6	.70
C815,816	Ceramic, 52pF, 10%, 500V, N1500	C50B652-53	.35
C817,818,827	Ceramic, 0.1uF, 35%, 100V	C51163-1	.80
C819,820	Electrolytic, 2000uF, 75V	CE22323-17	4.00
C821,822	Ceramic, 0.02uF, +80-20%, 100V	C50B570-2	.45
C823,824,825,826	Ceramic, 680pF, 10%, 500V	C50B651-2	.30
CR801,802,803,804	Stabistor, Silicon	SIT51B096-9	.40
CR805,806	Stabistor, Silicon	SIT51B096-2	.75
Q801,802	Transistor (SPS2297)	TR02051-3	1.00
Q803,804	Transistor (SJ5589)	TR01056-5	2.20
Q805,806	Transistor (SPS2292) or (SS1821)	TR01053-5 or TR01062-7	2.05 2.55
Q807,808	Transistor (SPS944MK)	TR01063-1	.85
Q809,810	Transistor (SPS944MK)	TR02063-1	.95
Q811,812	Transistor (SJ2550MK)	TR01064-7	8.05
Q813,814	Transistor (SJ2551MK)	TR02064-7	10.05
R801,802	180K	R33DC184J	.30
R803,804	3.9K	R33DC392J	.30
R805,806	68K	R33DC683J	.30
R807,808	6.8K	R33DC682J	.30
R809,810	Composition, 100, 5%, 1/4W	RC07BF101J	.40
R811,812	33K	R33DC333J	.30
R813,814,815,816,817,818	1.2K	R33DC122J	.30
R819,820	270	R33DC271J	.30
R821,822	Variable, 1K	R50B150-19-2	.90
R823,824	Composition, 1.2K, 5%, 1/4W	RC07BF122J	.40
R825	560	R33DC561J	.30
R827,828,829,930	10K	R33DC103J	.30
R831,832,833,834	150	R33DC151J	.30
R835,836,837,838	680	R33DC681J	.30
R839,840,841,842	Wirewound, 0.47, 5%, 5W	RW5WR47J	.55
R843,844	Composition, 10, 10%, 1/2W	RC20BF100K	.40
R845	82K	R33DC823J	.30
R847,848	Composition, 12, 5%, 1/4W	RC07BF120J	.40

NOTE: Unless otherwise specified, all resistors are Deposited Carbon Film in ohms, 5%, 1/3 Watt.
K = Kilohms, M = Megohms

PB2267-1, -2 POWER SUPPLY

Symbol	Description	Part No.	Sug. Ret.
C951	Ceramic, 330pF, +80-20%, 1400V	C50404-3	.45
*C951	Ceramic, 330pF, 20%, 400VAC	C51164-1	.90
C952,953 954	Ceramic, 0.02uF, 20%, 500V	C50B567-3	.35
C955	Electrolytic, 1000uF, +50-20%, 15V	CE22337-2	1.70
C956	Electrolytic, 100uF, 15V	CE22326-12	.70
C957	Electrolytic, 4000uF, 70V	CE22323-22	5.75
C958	Ceramic, 0.01uF, 20%, 500V	C50089-3	.35
C959	Electrolytic, 1.0uF, 63V	CE22324-31	.65
C960	Ceramic, 0.01uF, +80-20%, 100V	C50B570-1	.40
C961	Electrolytic, 220uF, 6.3V	CE22324-4	.70
C962	Electrolytic, 100uF, 25V, 100°C	CE22332-1	1.30
C963	Electrolytic, 1000uF, 40V	CE22324-28	2.05
C964	Electrolytic, 100uF, +100-10%, 85V	CE22337-1	1.45
CR951, 952,953, 954	Diode, Silicon, 5A, 200V	SID51C169-2	.95
CR955	Diode, Silicon, 1.5A, 200V	SID51C052-19	.50
CR956A, B	Dual Zener Module	TR14004-1	1.75
CR956A	Zener Regulator, 20V, 3%, 1W	TR14002-13	1.00
CR956B	Zener Regulator, 15V, 3%, 1W	TR14002-12	1.00
F951	Fuse, Slo-Blo, 7A, 125V, Pigtail	FL51313-9	.80
L951	RF Choke, 0.55uH	LC21818	.60
Q951	Transistor	TR02053-5	1.60
Q952,953	Transistor	TR01045	4.00
R951	Composition, 820K, 10%, 1/2W	RC20BF824K	.30
R952	Wirewound, 0.51, 5%, 2W	RW200WR51J	.60
R953	1K	R33DC102J	.30
R954,955	33	R33DC330J	.30
R956	Wirewound, 47, 5%, 2W	RW200W470J	.45
R957	47K	R33DC473J	.30
R958	220	R33DC221J	.30
R959	Wirewound, 150, 5%, 2W	RW200W151J	.55
R960	Thermistor, 300, 10%, NTC	RT51092-14	.75
R960A	1.2K	R33DC122J	.30
R961	Wirewound, 150, 5%, 10W	RW10W151J	.50
R962	10K	R33DC103J	.30
R963, 964, 965, 966	Wirewound, 220, 5%, 2W	RW200W221J	.45
R967,968	Wirewound, 100, 5%, 2W	RW200W101J	.45
S901A,B	Speakers Switch	SR2252-116	8.25

*Used in PB2267-2 only

WT-50 REMOTE CONTROL TRANSMITTER PX4079 PB2249-1

Symbol	Description	Part No.	Sug. Ret.
C601	Tantalum, 10uF, 25V	CL22305-17	.90
C602	Ceramic, 0.1uF, +80-20%, 12V	CK22315-2	.45
C603	Mylar, 0.01uF, 10%, 100V	CY22335-1	.90
C604	Polystyrene, 5100uF, 5%, 33V	C51B256-27	.90
C605	Ceramic, 1000pF, 10%, 50V	CK 22350-12	.30
Q601,602	Transistor	TR01014	.50
R601	Dep. Carb., 12K, 5%, 1/4W	RF25DC123J	.30
R602	Dep. Carb., 3.3K, 5%, 1/4W	RF25DC332J	.30
R603	Dep. Carb., 820, 5%, 1/4W	RF25DC821J	.30
R604	Dep. Carb., 1K, 5%, 1/4W	RF25DC102J	.30
R605	Dep. Carb., 100, 5%, 1/4W	RF25DC101J	.30
S601	Pushbutton Switch	EA4079-108	.30
---	Battery (9V)	EC51368	1.95
---	Ceramic Ultrasonic Transducer	UT22108	7.45

PB2244-1 REMOTE PICKUP

Symbol	Description	Part No.	Sug. Ret.
C651	Ceramic, 0.1uF, +80-20%, 12V	CK22315-1	.45
C652	Ceramic, 470pF, 10%, 500V	C50B651-13	.35
C653	Tantalum, 0.47uF, 35V	CL22305-1	.80
C654	Electrolytic, 10uF, 63V	CE22339-1	.65
C655	Mylar, 0.01uF, 5%, 160V	C50B647-18	.50
C656	Ceramic, 5000pF, 20%, 500V	C50B567-2BX	.30
C657	Ceramic, 0.1uF, +80-20%, 16V	C51163-1	.80
C658	Electrolytic, 22uF, 35V	CE22339-2	.65
C659	Tantalum, 47uF, 6V	CL22305-16	.90
C660	Ceramic, 330pF, ±10%, 500V	C50B651-1	.30
CR651	Silicon Diode	TR13006-2	.35
IC651	Linear Integrated Circuit	TR09013	6.75
L651	Coil, 5.25mH	L50B334-1	.90
Q651	Transistor BC147B	TRBC147B	1.05
R651,658	Dep. Carb., 33K, 5%, 1/4W	RF25DC333J	.30
R652	Dep. Carb., 1M, 5%, 1/4W	RF25DC105J	.30
R653	Dep. Carb., 150K, 5%, 1/4W	RF25DC154J	.30
R654	Dep. Carb., 180K, 5%, 1/4W	RF25DC184J	.30
R655	Dep. Carb., 1.8K, 5%, 1/4W	RF25DC182J	.30
R656	Dep. Carb., 6.8K, 5%, 1/4W	RF25DC682J	.30
R659	Dep. Carb., 56K, 5%, 1/4W	RF25DC563J	.30
---	Ceramic Ultrasonic Transducer	UT22109	7.45

NOTE: Unless otherwise specified, all resistors are Deposited Carbon Film in ohms, 5%, 1/3 Watt.
K = Kilohms, M = Megohms

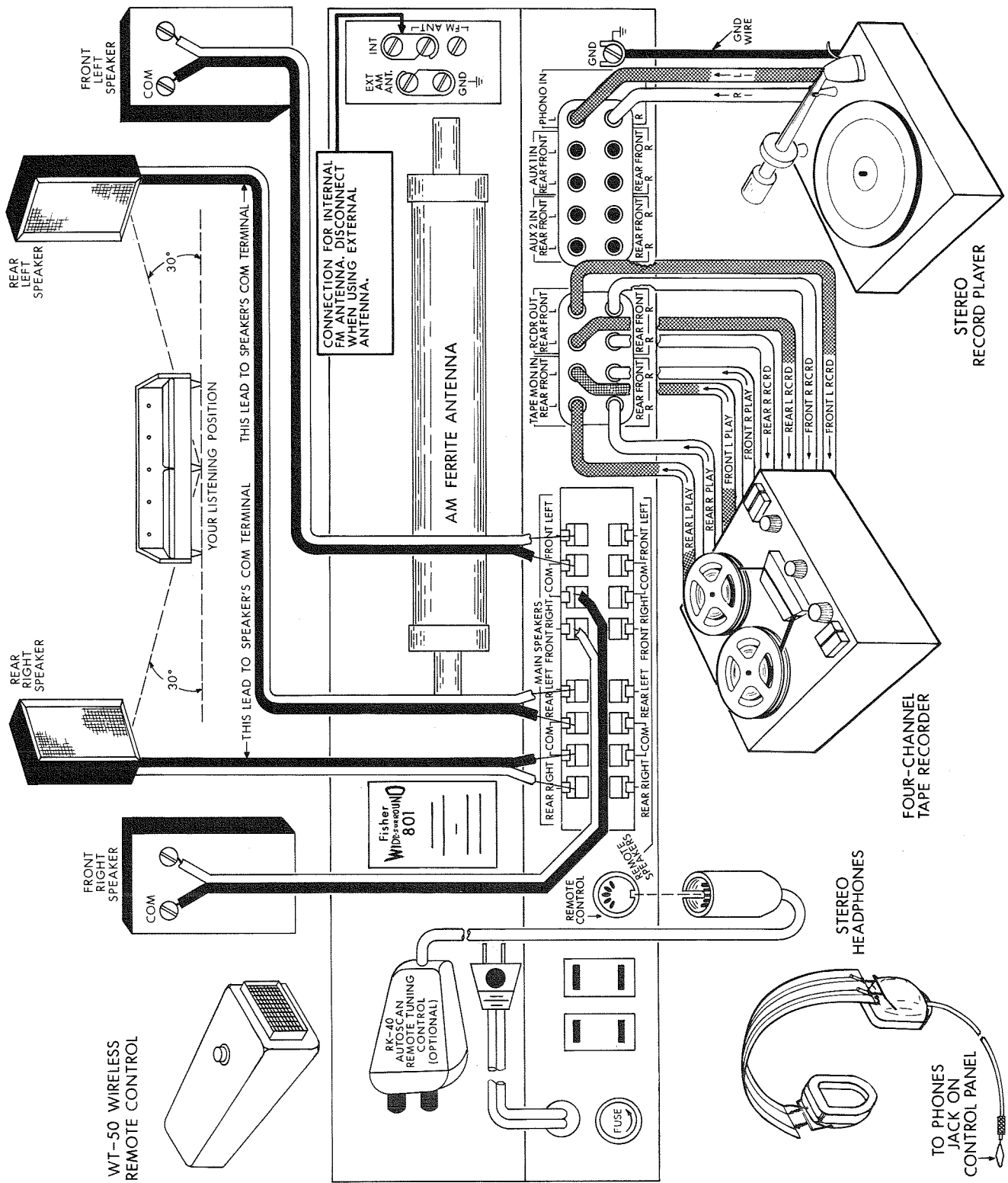

AL4072-171

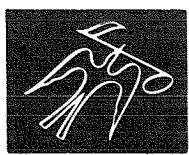

BECAUSE ITS PRODUCTS ARE SUBJECT TO CONTINUOUS IMPROVEMENT, FISHER RADIO RESERVES THE RIGHT TO MODIFY ANY DESIGN OR SPECIFICATION WITHOUT NOTICE AND WITHOUT INCURRING ANY OBLIGATION.

FISHER RADIO • LONG ISLAND CITY • NEW YORK 11101