

SERVICE MANUAL

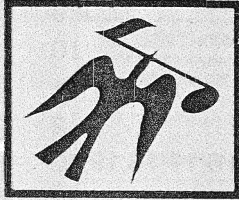

FISHER

AD-823

**Digital Compact
Disc Player
(EUROPE)**



137 309 40

CONTENTS

Specifications	3
Functional Block Diagram	4
Safety Certification	5
Laser Beam Radiation Spot	5
Disassembly Instructions	6,7
Cabinet & Chassis Exploded View	8,9
Cabinet & Chassis Parts List	10
Mechanism Exploded View	11
Mechanism Parts List	12
Adjustment Procedures	13,14,15,16,17,18,19,20
P.C.Board Alignment Points	21
Installation Method for Each Leaf Switch	22
Input Port Assignments	23
Output Port Assignments	23
System Block Diagram & Pin Location	24
Printed Circuit Board (Bottom View)	25,26,27,28,29,30
P.C.Board Parts List	31,32,33,34,35
Safety Interlock	36
Point to Point Wiring Diagram	37,38
Schematic Diagram	39,40,41,42,43
IC Signal Flow & Equivalent Circuit	44,45,46,47
Semiconductor Lead Identification	48

SPECIFICATIONS

DIGITAL COMPACT DISC PLAYER	AD-823
System	Compact disc digital audio system
AUDIO CHARACTERISTICS	
Frequency Response	5 Hz – 20 kHz, ± 0.5 dB
Harmonic Distortion	Less than 0.03 % (1 kHz)
S/N Ratio	More than 90 dB
Wow and Flutter	Unmeasurable
Channel Separation	More than 80 dB (1 kHz)
Output Voltage max.	2 Vrms
FUNCTIONS	
Instant Selection	Sequential, with F-FWD and F-BACK buttons
Instant Index	Sequential, with INDEX ► and INDEX ◀ buttons
Repeat	All selections or one selection
Reset	Press STOP button twice
Pause	Each selection
Disc Loading	Motor driven horizontal loading
DIGITAL SIGNAL PROCESSING	
Optical Pickup	3-beam laser
Error Correction	CIRC
Sampling Frequency	44.1 kHz
D/A Conversion	16-bit linear
Filter	Digital filter + (2-pole CR filter)
GENERAL	
Power Requirements (50 Hz)	AC 110/220 V 20 Watts
Dimensions (WxHxD)	440 x 86 x 290mm
Weight (approx.)	3.9 kg

Because its products are subject to continuous improvement, Fisher Corporation reserves the right to modify product designs and specifications without notice and without incurring any obligation.

SAFETY CERTIFICATION

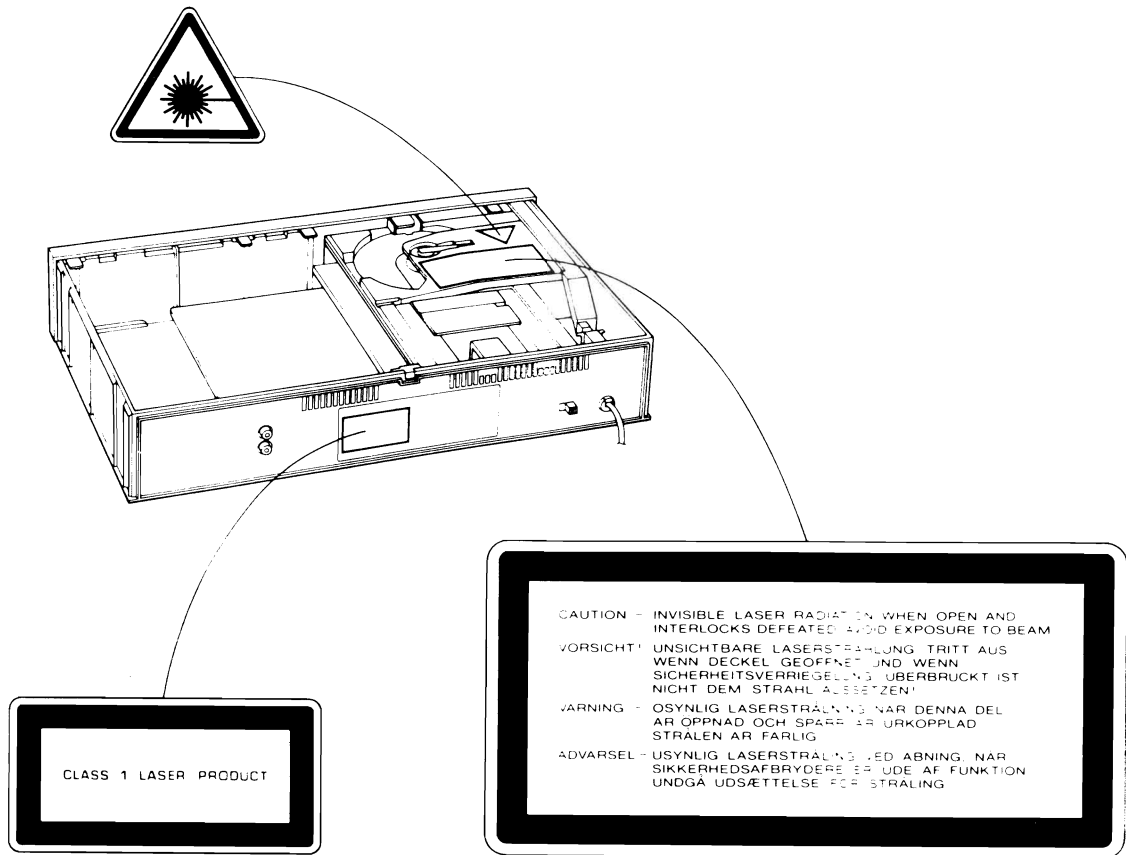

ACHTUNG – WENN ANDERE ALS DIE HIER BESCHRIEBENEN BEDIENUNGS- ODER JUSTIEREINRICHTUNGEN BENÜTZT ODER ANDERE ARBEITEN AUSGEFÜHRT WERDEN, KANN DIES ZU GEFÄHRLICHER STRAHLUNGSEINWIRKUNG FÜHREN.

ATTENTION – L'EMPLOI D'ORGANES DE COMMANDE OU DE RÉGLAGE, OU L'EXÉCUTION DE PROCÉDURES, AUTRES QUE CEUX SPÉCIFIÉS DANS LE MODE D'EMPLOI, PEUT PROVOQUER UNE EXPOSITION DANGÉREUSE AU RAYONNEMENT.

CAUTION – USE OF CONTROLS OR ADJUSTMENTS OR PERFORMANCE OF PROCEDURES OTHER THAN THOSE SPECIFIED HEREIN MAY RESULT IN HAZARDOUS RADIATION EXPOSURE.

VARNING – BRUK AV KONTROLLER, JUSTERINGAR ELLER MANÖVRERING AV APPARATEN ANNAT ÄN HÄRI ANGIVNA KAN INNEBÄRA STRÅLNINGSRISK.

OPGELET – HET GEBRUIK VAN REGELAARS OF HET MAKEN VAN AFSTELLINGEN E.D. DIE NIET IN DEZE GEBRUIKSAANWIJZING ZIJN BESCHREVEN KAN LEIDEN TOT SCHADELIJKE STRALINGEN.

CAUTELA – L'USO DI COMANDI, AGGIUSTAMENTI O PROCEDIMENTI DIVERSO DA QUELLO GIÙ SPECIFICATO PUÒ DAR LUOGO AD ESPOSIZIONE A RADIAZIONI PERICOLOSE.

LASER BEAM RADIATION SPOT

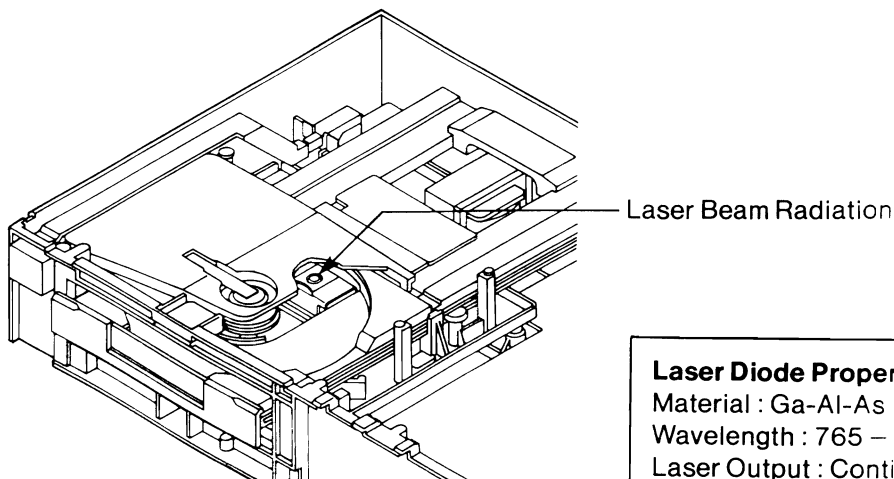

Laser Diode Properties

Material : Ga-Al-As

Wavelength : 765 – 820 nm (25°C)

Laser Output : Continuous Wave max. 0.5 mW

DISASSEMBLY INSTRUCTIONS

REMOVING COVER

1. Lift and disassemble the cover by removing the five mounting screws on the cover. (No. 1 ~ 5)

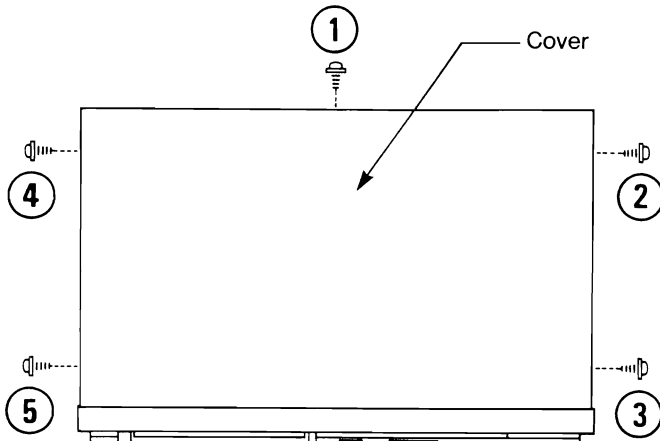

3. Slide out the closed table load with your hand to open it again. It can be pulled out smoothly as it gets out of gear at this time.
4. Sliding out the table load, pull it out by moving the hook in the direction of the arrow.

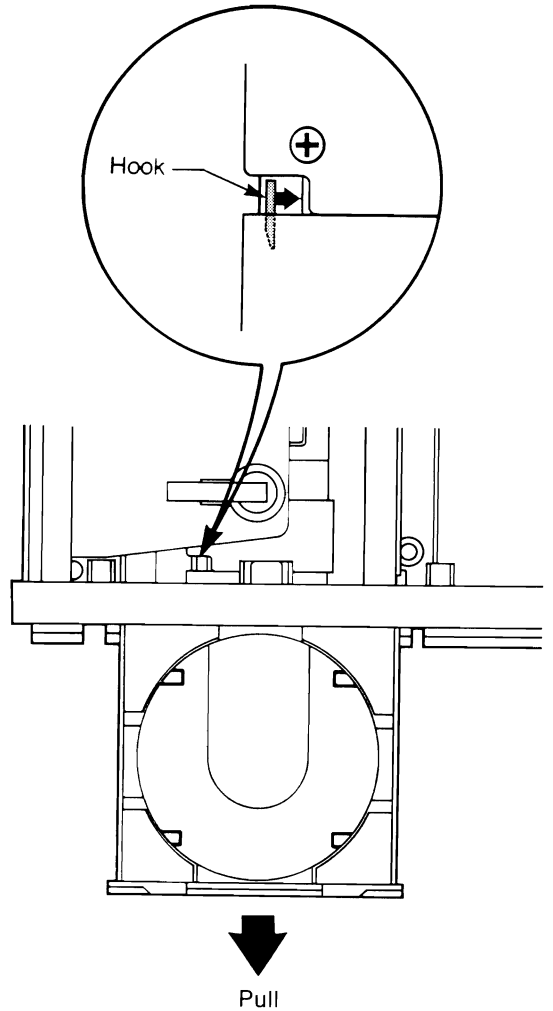

REMOVING TABLE LOAD

1. After removing the cover, switch on the power and open the table load by pressing the OPEN/CLOSE button.
2. With the table load being opened, switch off the power and push the table load with your hand to close it.

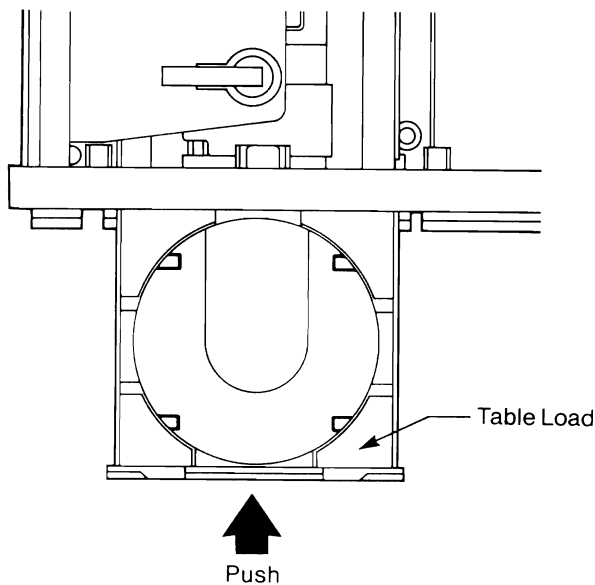

REMOVING FRONT PANEL

1. After removing the table load, disassemble the front panel by removing eight mounting screws on the front panel. (No. 6 ~ 13)

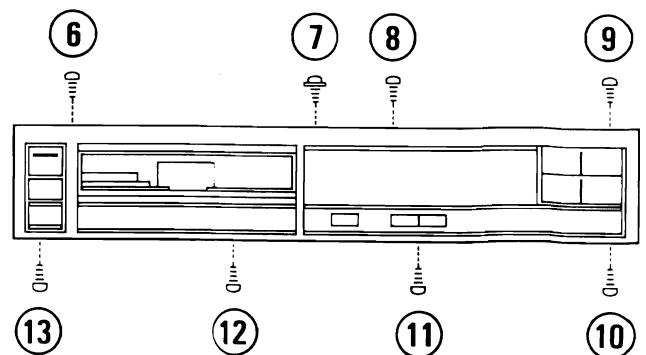

DISASSEMBLY INSTRUCTIONS (Continued)

REMOVING MECHANICAL ASSEMBLY

1. After removing the front panel, disassemble the shaft of the power switch.
2. Disassemble the mechanical assembly by removing the four mounting screws fixing it. (No. 14 ~ 17)

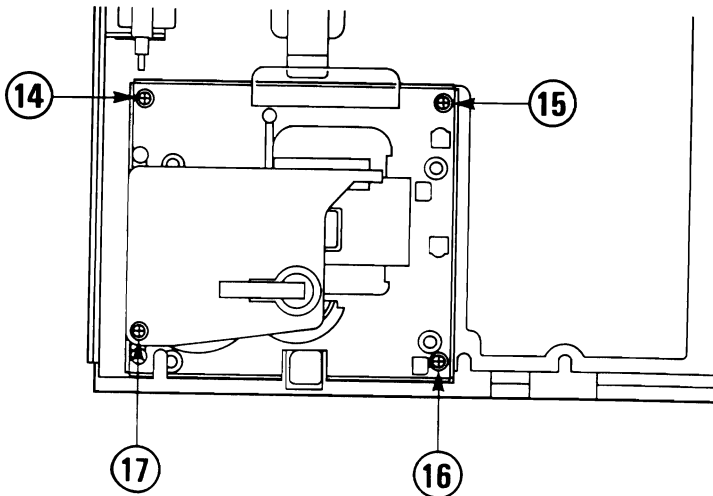

REMOVING SERVO P.C.BOARD

1. After removing the mechanical assembly, disassemble the Servo P.C.Board by removing the two mounting screws. (No. 24, 25) If necessary, unsolder the leads.

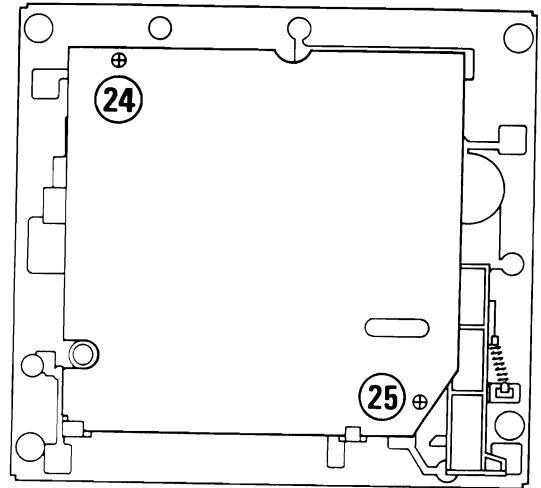

REMOVING CONTROL P.C.BOARD

1. After removing the front panel, disassemble the control board by removing eight mounting screws fixing it.

REMOVING MAIN P.C.BOARD

1. After removing the mechanical assembly, disassemble the Main P.C.Board by removing the six mounting screws fixing it. (No. 18 ~ 23)
- c) The mechanical assembly and the front panel have been removed.

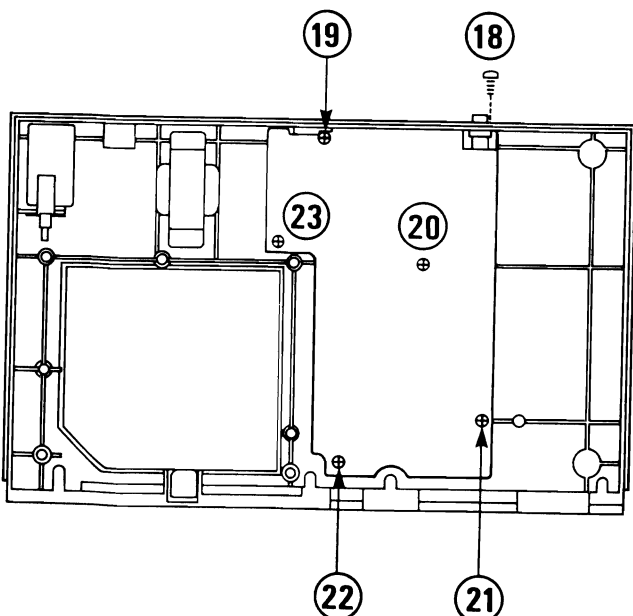

CABINET & CHASSIS EXPLODED VIEW (1)

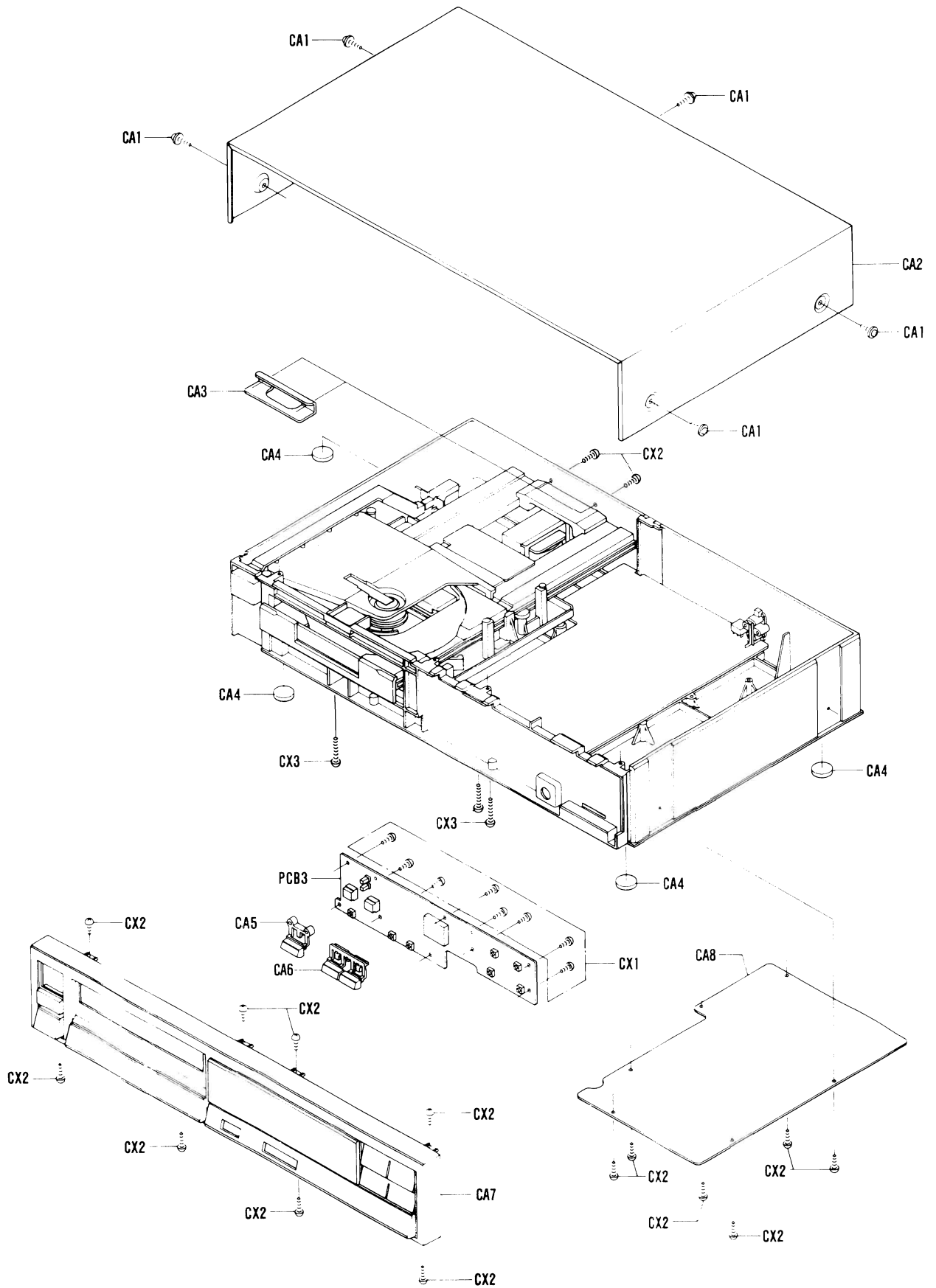

CABINET & CHASSIS EXPLODED VIEW (2)

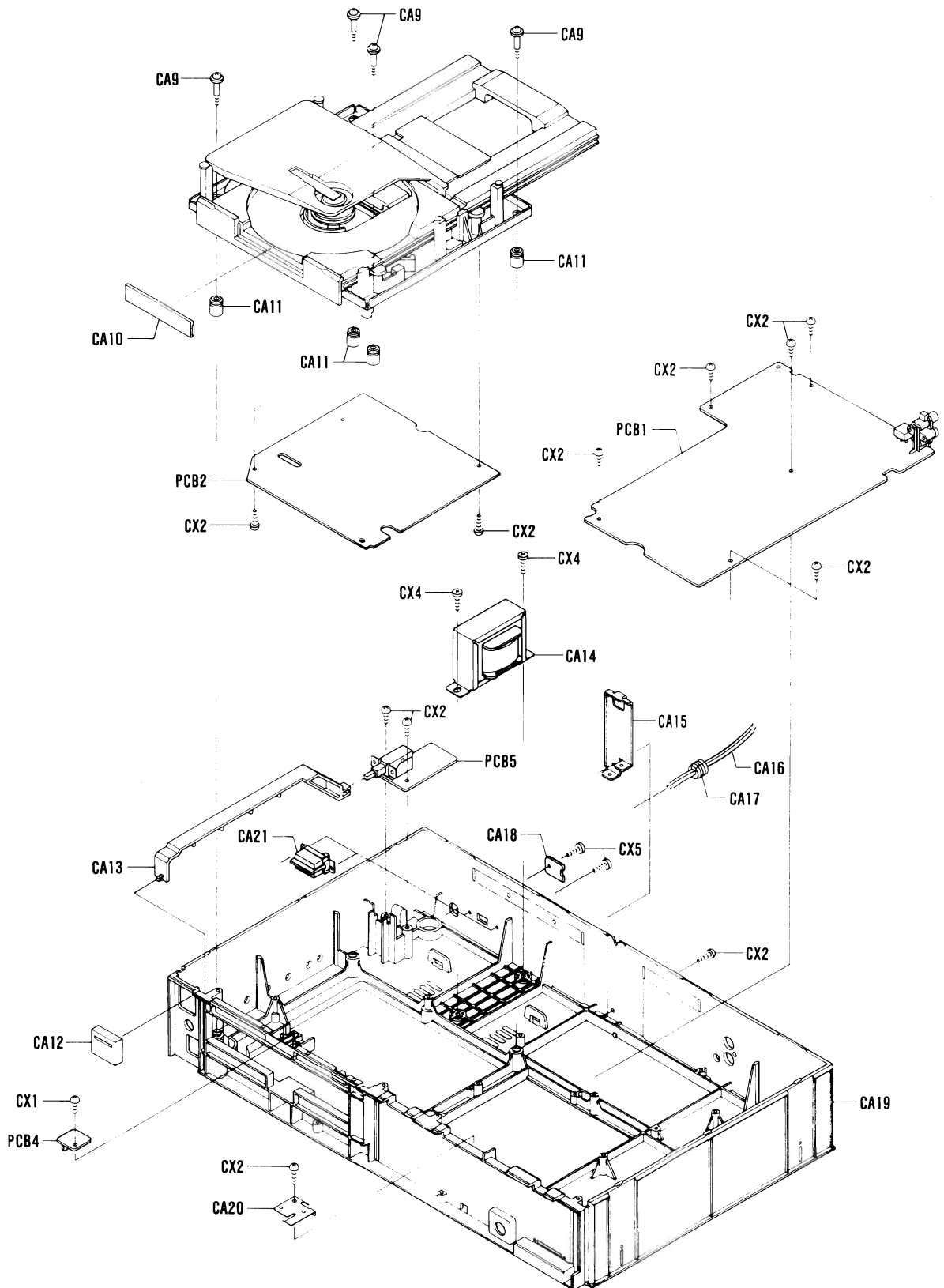

CABINET & CHASSIS PARTS LIST

Ref. No.	Part No.	Description	Q'ty	Ref. No.	Part No.	Description	Q'ty
PACKAGE							
	3-9415-10300	Bag Polyethylene	1	CX1	143-3-1903-00611	Screw, Brazier Hd. Tapping-B, +M3.0x6	9
	131-6-1169-16402	Box Corrugate Exp	1	CX2	143-3-1903-00818	Screw, Brazier Hd. Tapping-B, +M3.0x8	28
	131-6-2119-02090	Bag Polyethylene Exp	1	CX3	143-3-1903-02011	Screw, Brazier Hd. Tapping-B, +M3.0x20	3
	131-6-3009-35590	Pad Left	1	CX4	103-3-1704-01011	Screw, Bind Hd. Tapping-2, +M4.0x10	2
	131-6-3009-35600	Pad Right	1	CX5	101-3-1303-00818	Screw, Pan Hd., +M3.0x8	2
	131-6-3069-16350	Patching Sheet	1	PCB1	141-0-1939-08262	Main P.C.B. Assy	1
	141-6-4559-03300	Serial No. Sheet	2	PCB2	141-0-1939-08270	Servo P.C.B. Assy	1
				PCB3	141-0-1939-08280	Control P.C.B. Assy	1
				PCB4	141-0-1939-08320	Disk Indicator P.C.B. Assy	1
				PCB5	141-0-1939-08291	Power Switch P.C.B. Assy	1
ACCESSORIES							
	4-2369-74130	Plug Cord	1	NOTES:			
	131-6-2719-10401	Bag Fan	1	1. Parts order must contain Model Number, Part Number and Description.			
	131-6-4519-15700	Guarantee Cert	1	2. Ordering quantity of screws and resistors must be multiple of 10 pcs.			
	141-6-4159-00622	Notes	1				
	141-6-4559-03300	Serial No. Sheet	1				
	142-6-4119-32540	Explanatory Booklet	1				
CABINET							
	4-2359-78414	Connector 1P Assy	1	<p style="text-align: center;">PRODUCT SAFETY NOTICE</p> <p>Each precaution in this manual should be followed during servicing. Components identified with the IEC symbol Δ in the parts list and the schematic diagram designate components in which safety can be of special significance. When replacing a component identified with Δ, use only the replacement parts designated, or parts with the same ratings of resistance, wattage or voltage that are designated in the parts list in this manual. Leakage-current or resistance measurements must be made to determine that exposed parts are acceptably insulated from the supply circuit before returning the product to the customer.</p>			
	141-2-2899-25700	Adhesive Sheet	1				
	131-2-1310-40502	Name Plate (Rating)	1				
	131-2-7103-50700	Label (Caution)	1				
	131-6-4159-39600	Notes (Laser)	1				
	131-6-4159-40200	Notes (Laser)	1				
	131-6-4159-40300	Notes (Laser)	1				
	131-6-4559-10900	Manufacturing No.	1				
CA1	141-2-4219-33101	Screw, Bind Hd. Tapping, +M3.0x8	5				
CA2	131-2-1410-32800	Cover	1				
CA3	131-2-3108-13000	Metal Stopper	1				
CA4	131-2-1801-16200	Leg	4				
CA5	131-2-1601-91100	Knob Touch S	1				
CA6	131-2-1601-91200	Knob Touch D	1				
CA7	131-0-1015-10901	Escutcheon Dial Assy	1				
CA8	131-2-1105-31300	Plate Bottom	1				
CA9	134-2-4106-27000	Shaft	4				
CA10	131-2-6308-23401	Filter	1				
CA11	131-2-5205-32700	Cushion Rubber	4				
CA12	131-2-1601-90900	Knob Power	1				
CA13	131-2-4219-19200	Shaft	1				
CA14	Δ 4-2512-31020	Power Trans	1				
CA15	131-2-3101-99800	Metal Mount Cover	1				
CA16	Δ 4-2432-00500	Power Cord	1				
CA17	141-2-3899-10400	Heyco Bushing	1				
CA18	131-2-7104-00500	Plate Pad Switch	1				
CA19	131-2-3301-31302	Chassis Main	1				
CA20	141-2-4729-10100	Lug Ground	1				
CA21	4-2312-01020	Switch Slide (Voltage Select) [SW104]	1				

MECHANISM EXPLODED VIEW

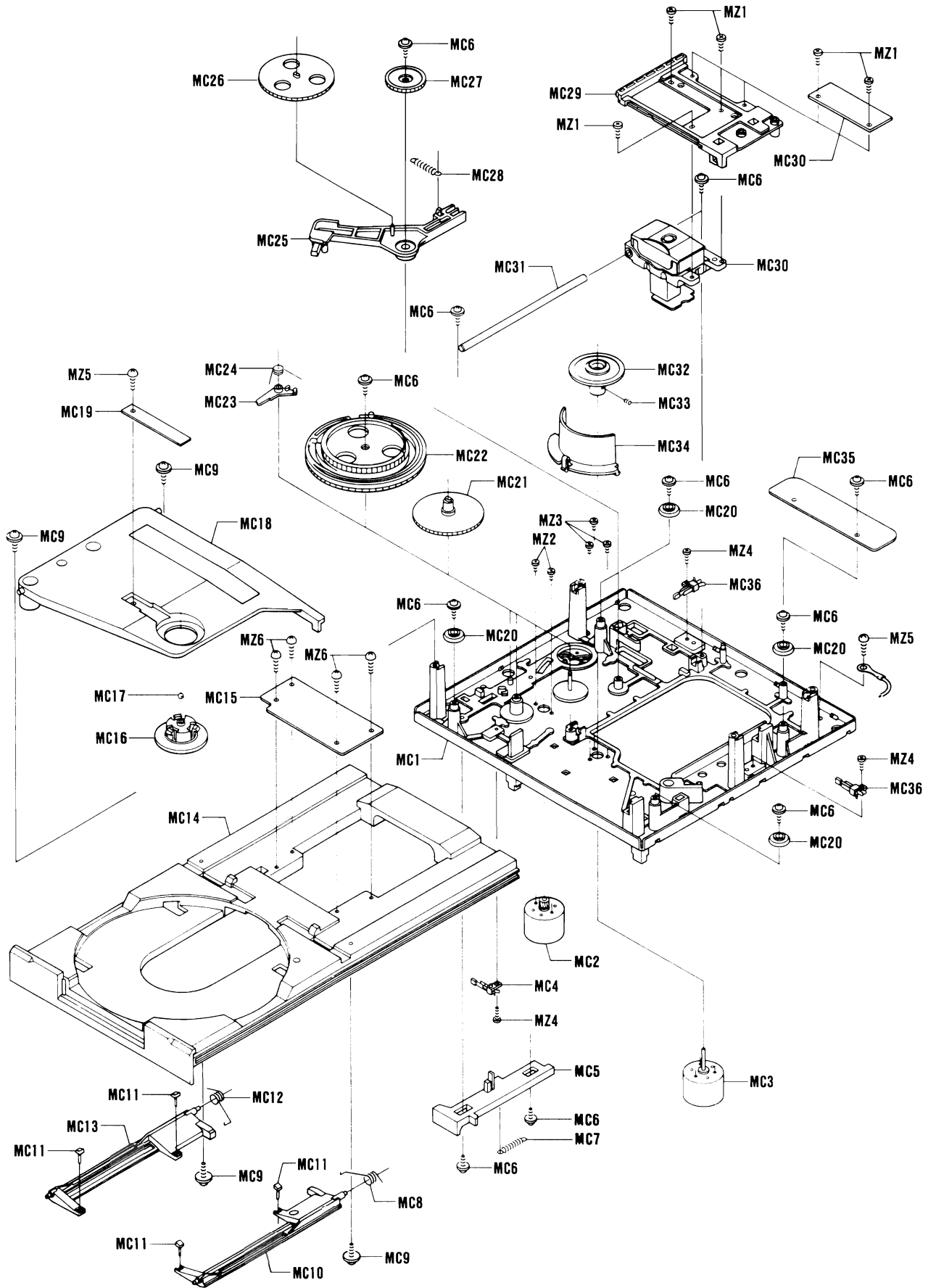

MECHANISM PARTS LIST

Ref. No.	Part No.	Description	Q'ty
MECHANISM			
MC1	141-0-3119-24600	Chassis Assy	1
MC2	141-0-5519-11500	Gear Motor Assy [M101]	1
MC3	4-5279-71420	Motor (Spindle) [M102]	1
MC4	4-2319-74170	Leaf Switch (Eject) [SW101]	1
MC5	141-2-7319-64500	Slide Eject	1
MC6	141-2-4219-05400	Screw Washer	11
MC7	141-2-8549-27700	Spring Slide Eject	1
MC8	141-2-8529-23700	Spring Lever Right	1
MC9	131-2-4201-28201	Screw	4
MC10	141-2-7419-94500	Lever Hold Disk Right	1
MC11	141-2-4459-36000	Pad Disk	4
MC12	141-2-8529-23800	Spring Lever Left	1
MC13	141-2-7419-94600	Lever Hold Disk Left	1
MC14	141-2-1149-40100	Table Load	1
MC15	141-2-3519-73900	Plate Reinf.	1
MC16	141-2-3519-72400	Holder Disk	1
MC17	141-2-8259-04800	Ball	1
MC18	141-2-6229-01400	Flap Disk Cramp	1
MC19	141-2-8539-53700	Spring Plate	1
MC20	141-2-8259-12600	Roller Table Load	4
MC21	141-2-5519-59900	Gear Load	1
MC22	141-2-5519-60000	Gear Cam	1
MC23	141-2-7419-94300	Lever Stop	1
MC24	141-2-8529-23900	Spring Lever Stop	1
MC25	141-0-7419-42400	Lever Rock Assy	1
MC26	141-2-5519-59800	Gear Pick-up	1
MC27	141-2-5519-59700	Gear Pinion	1
MC28	141-2-8549-27800	Spring Lever Rock	1
MC29	141-0-7319-29400	Slide Base Pick-up Assy	1
MC30	134-0-4009-04000	Pick-up Assy	1
MC31	141-2-7519-72100	Shaft Pick-up	1
MC32	141-2-5229-00600	Turntable	1
MC33	141-2-4219-36700	Set Screw, V-cone, M2.0x4	1
MC34	141-2-2419-31300	Shelter Turntable	1
MC35	141-2-8219-36000	Stopper Lead	1
MC36	4-2319-75281	Leaf Switch (Pick-up Limit) [SW102]	1
MC36	4-2319-75281	Leaf Switch (Loading Limit) [SW103]	1
MZ1	101-3-1702-60411	Screw, Bind Hd., +M2.6x4	5
MZ2	128-3-1317-02013	PI Screw-3, Pan Hd., +M1.7x2.0	2
MZ3	128-3-1317-02518	PI Screw-3, Pan Hd., +M1.7x2.5	3
MZ4	143-3-1702-00611	Screw, Bind Hd. Tapping-B, +M2.0x6	3
MZ5	143-3-1903-00618	Screw, Brazier Hd. Tapping-B, +M3.0x6	2
MZ6	143-3-1903-00818	Screw, Brazier Hd. Tapping-B, +M3.0x8	4

NOTES:

1. Parts order must contain Model Number, Part Number and Description.
2. Ordering quantity of screws and resistors must be multiple of 10 pcs.

ADJUSTMENT PROCEDURES

BEFORE STARTING ADJUSTMENTS

- Make adjustments in the order of the item numbers. When a certain item has been adjusted, make all the adjustments following that item.
- When making the adjustment, refer to the disassembly procedure. Remove the mechanism, place an insulator board in the chassis, and it is convenient to place the mechanism on top of this. (Leave the wires connected.)

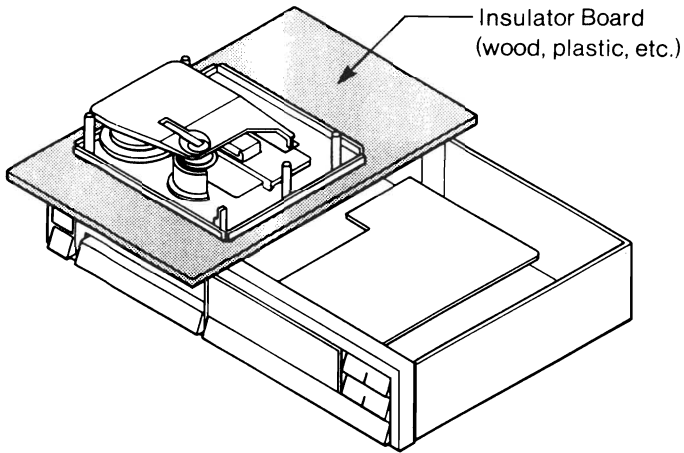

- Concerning the test points and adjustment volume shown in the adjustment items, refer to the P.C.Board Alignment Points.

REQUIRED EQUIPMENTS

- DC voltmeter
- Dual trace oscilloscope
- Frequency counter
- Low-frequency oscillator
- Laser power meter
- Plastic screwdriver
- Diffraction grating adjustment jig
- Test disc (Sony: YEDS7, Sony: YEDS4)

1. CONFIRMING LASER OUTPUT

1. Short between **F2** and **H1**, the test points of the Main P.C.Board.
2. Make the laser output section visible by removing the flap disc clamp.
3. Switch on the power and press the PLAY/PAUSE button once to get the laser output continuously. Applying the laser sensor of the laser power meter to the emitter, make sure that the output is in the range of 0.25mW and 0.5mW.
4. Reinstall the flap disc clamp and repair the short between **F2** and **H1**.

2. PLL FREE RUN

1. Introduce 10k Ω of a resistance between **HF** and **GND**, test points of the Main P.C.Board.
2. Connect the frequency counter to between **CK** and **GND** of the test points of the Main P.C.Board by using a probe.
3. Adjust the generation coil L101 with a plastic screwdriver for getting a indication in the range of 4.320MHz and 4.330MHz on the frequency counter.
4. Remove the resistance between **HF** and **GND**.

3. TENTATIVE SETTING OF VOLUME

1. Set the semi-fixed resistance tentatively as follows:

VR601 (FOCUS OFFSET)	Center Position
VR602 (FOCUS GAIN)	Center Position
VR603 (E-F BALANCE)	Center Position
VR604 (TRACKING OFFSET)	Center Position
VR605 (TRACKING GAIN)	Turn to the end counter-clockwise.
VR606 (KICK GAIN)	Center Position

4. FOCUS OFFSET ADJUSTMENT

1. Turn on the power and keep it in the state of "STOP".
2. Connect a DC voltmeter to the focus error test terminal and adjust the VR601 to make DC voltage in the range of 0V \pm 10mV.

5. TRACKING OFFSET ADJUSTMENT

1. Turn on the power and keep it in the state of "STOP".
2. Connect a DC voltmeter to the tracking error test terminal and adjust the VR604 to make DC voltage in the range of 0V \pm 10mV.

ADJUSTMENT PROCEDURES (Continued)

6. GRATING ADJUSTMENT

1. This player adopts the 3-beam method for its optical pickup. The grating adjustment is made by adjusting the relative location of the E-beam and the F-beam to the main beam on a bit line as shown in the following figure.

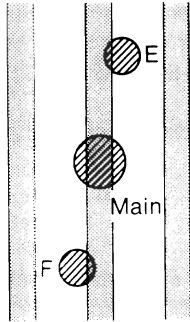

For adjustment, arrange them in a line at first, then, adjust them for the specified location.

5. When the disc starts to rotate, an waveform can be observed on the oscilloscope. With observing the waveform, turn the gear little by little with your hand in the direction of the arrow to send the pickup outward.

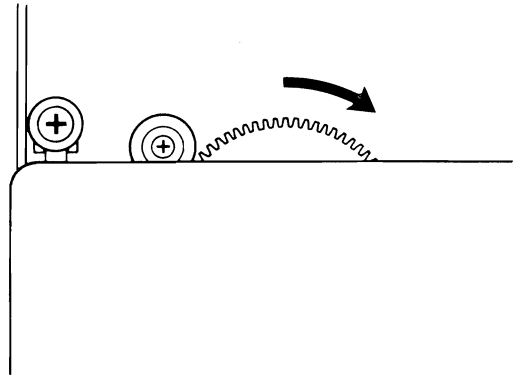

6. When the pickup comes close to the external track, the waveform on the oscilloscope disappears once, and then appears again. This is the place showing the track for a multi-burst signal.

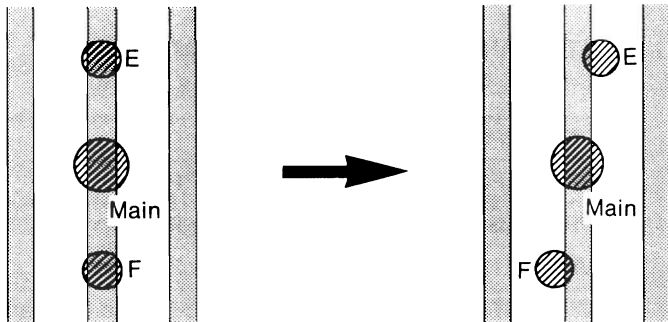

The procedures of this adjustment are as follows. Adjust with care as they are fine tuning.

1. Make sure that the VR605 is turned counterclockwise to the end.
2. Loading the test disc YEDS7 on the turntable, short between the test points, **H1** and **F2**, of the main board.
3. Connect the each channel of the dualtrace oscilloscope to the each pin of No. 10 and No. 12 on the IC601 of E/F output.
4. Switching on the power, make sure that the disc stops after several minutes of rotation. Then, keep the PLAY/PAUSE button pressed until the disc restarts to rotate.

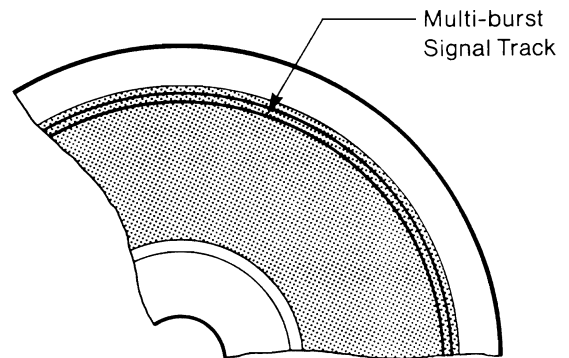

7. When the pickup comes in the track for a multi-burst signal, turn the VR605 to the center point and command the tracking servomechanism. At this time, if the burst signals of the E-beam and the F-beam are synchronous, the two beams are on the same bit line. And if they are not synchronous each other, they are not on the same bit line.

ADJUSTMENT PROCEDURES (Continued)

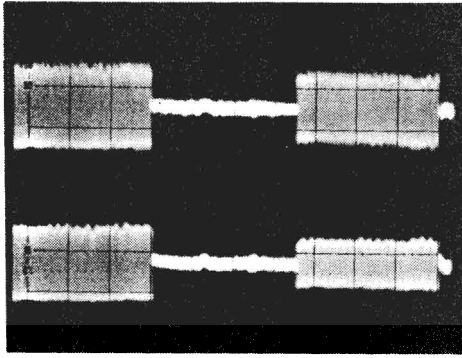

The two beams are on the same bit line.
(50mV/DIV : 5mSec/DIV)



In the above item 7, if the three beams were not in one bit line, put the jig into the adjusting hole and turn it to the left or to the right. When the waveforms form almost one line without a phase difference as shown in the figure, you can know the beams are in a line.

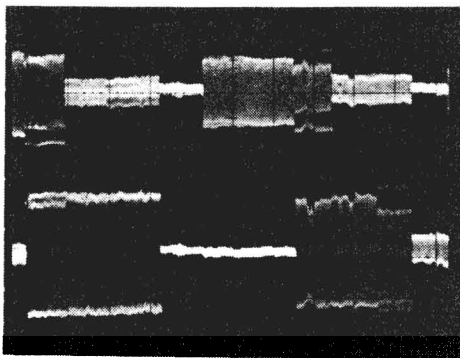

The two beams are not on the same bit line.
(50mV/DIV : 5mSec/DIV)

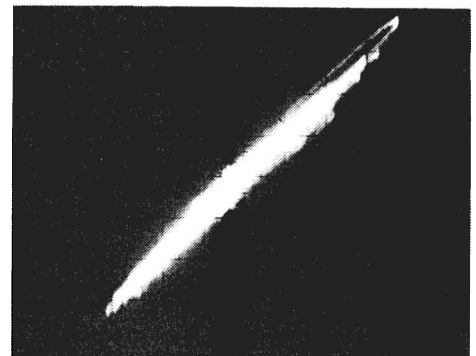

8. In this state, connect the following band-pass filters between; each of No. 10/No. 12 pins and the oscilloscope for observing the Lissajous's waveforms.

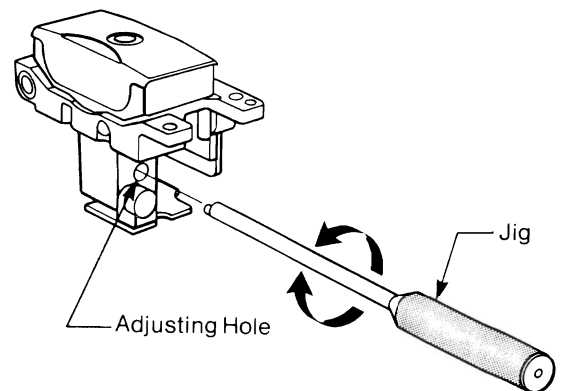
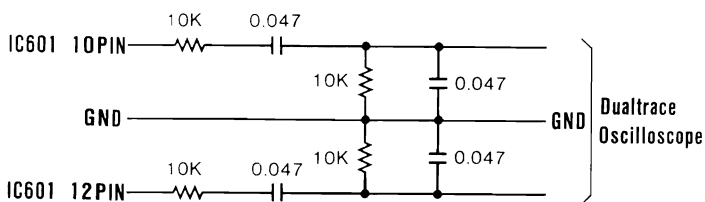

9. In the case that the three beams are on the same bit line with showing the waveforms are almost in a line by a phase difference of 180°, it means the grating has been adjusted. If required, adjust it by putting an adjusting jig into the hole for adjusting grating.

In this state, turn the jig clockwise to make the phase difference 180° with keeping the waveform in a line.

ADJUSTMENT PROCEDURES (Continued)

10. After completing the adjustment in the item 9, make sure that the E-beam and the F-beam are on the same bit line by the waveforms showing in the item 7.
11. Repair the short between **H1** and **F2**.

7. TENTATIVE ADJUSTMENT OF E-F BALANCE

1. Turn the VR605 counterclockwise to the end.
2. Loading the test disc YEDS4 on the turntable, short between the test points **H1** and **F2** on the main board.
3. Connecting the following low-pass filters to the tracking error test terminal, connect them to a DC voltmeter and an oscilloscope.

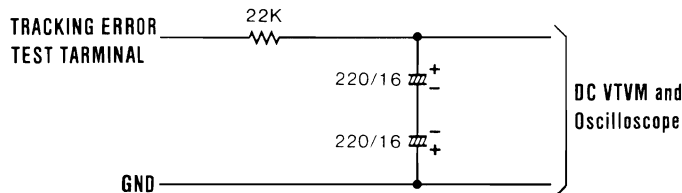

4. Switching on the power, make sure that the disc stops after several minutes of rotation. Then, keep the PLAY/PAUSE button pressed until the disc restarts to rotate.
5. After the disc starts to rotate, adjust the VR603 for reading the least value on the DC voltmeter.
6. Repair the short between **H1** and **F2**.

8. ADJUSTING INCLINATION OF PICKUP

1. Load the test disc YEDS4 on the turntable with the VR605 at the center point.
2. Connect an oscilloscope between the test points, **HF** and **GND** on the Main P.C.Board.
3. Turning on the power, play the fourth tune of the YEDS4. Turn the adjusting screw to get a **HF** waveform with the largest amplitude and a sharp waveform on the oscilloscope.

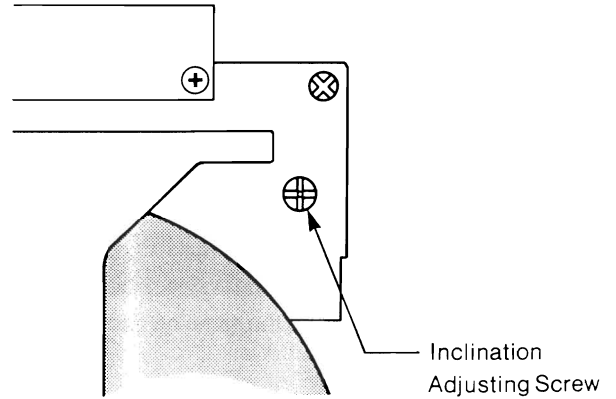

9. CONFIRMING JITTER

This procedure can be omitted in the case that no jitter counter is equipped.

1. As same in the adjustment of the pickup inclination, play the fourth tune of the YEDS4.
2. Connecting the jitter counter to the test point **EFMX** of the Main P.C.Board, make sure that the value of 3T is less than 25mS.
3. In the case of 25mSec or more, adjust again the inclination of the pickup.

10. ADJUSTMENT OF E-F BALANCE

1. After making the same adjustment as in the tentative E-F balance adjustment, adjust the VR603 for getting $0V \pm 15mV$ on the DC voltmeter.

11. ADJUSTING STARTING POSITION

1. Load the test disc YEDS4 on the turntable with the VR605 at the center point.
2. Turning on the power, start the disc. After the initial lead has passed following to a rotation of the disc, short across the test points, **TIME** and **GND** of the Main P.C. Board.
3. At this time, if the value on the TRACK/INDEX counter is not in the range of 1.2 ~ 1.5, repeat the procedures from the initial lead. after turning the starting position adjusting screw.
4. After the indication comes in the range of 1.2 ~ 1.5, make a fine adjustment of the starting point adjusting screw visually further to make the gap of the leaf switch at the inner circumference detector side as follows:

ADJUSTMENT PROCEDURES (Continued)

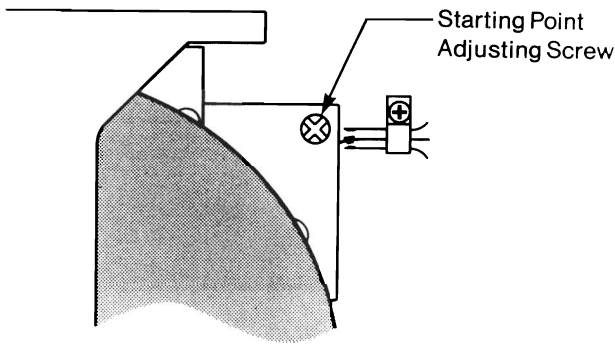

Indication – (Gap of Leaf Switch)
 1.2 – (0mm) 1.3 – (0.1mm) 1.4 – (0.2mm) 1.5 – (0.3mm)

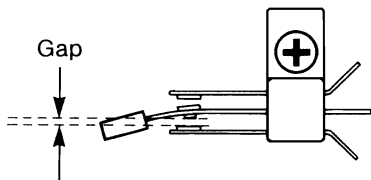

12. ADJUSTING HEIGHT OF TURNTABLE

When the motor is replaced, this adjustment is required.

1. Install the turn table as the height from the chassis to the lower end of the turntable is 21.5mm.

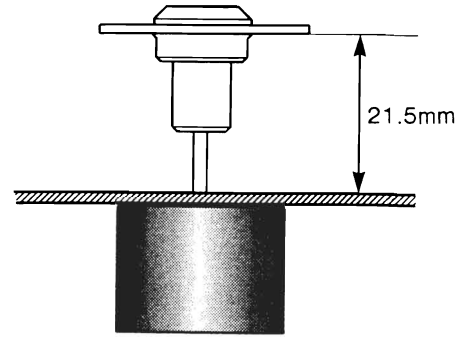

2. Load the test disc YEDS4 on the turntable with the VR605 at the center point.
3. Connecting the following low-pass filter to the focus coil test terminal, connect them to a DC voltmeter and an oscilloscope.

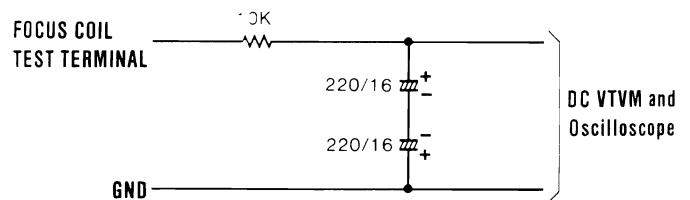

4. Turning on the power, play the first tune of the disc.
5. After checking the voltmeter for reading, adjust the height of the turntable for a reading of $0V \pm 0.25V$. (When the figure of the volt meter shows "+", move up the turntable and when it shows "-", move it down. In this circuit, it moves by 0.85mm per 1V.)

13. ADJUSTING FOCUS / TRACKING GAIN

The following circuits for measuring is required for adjusting the focus gain and the tracking gain accurately. If this circuit is not available, adjust them by using the plain adjusting method.

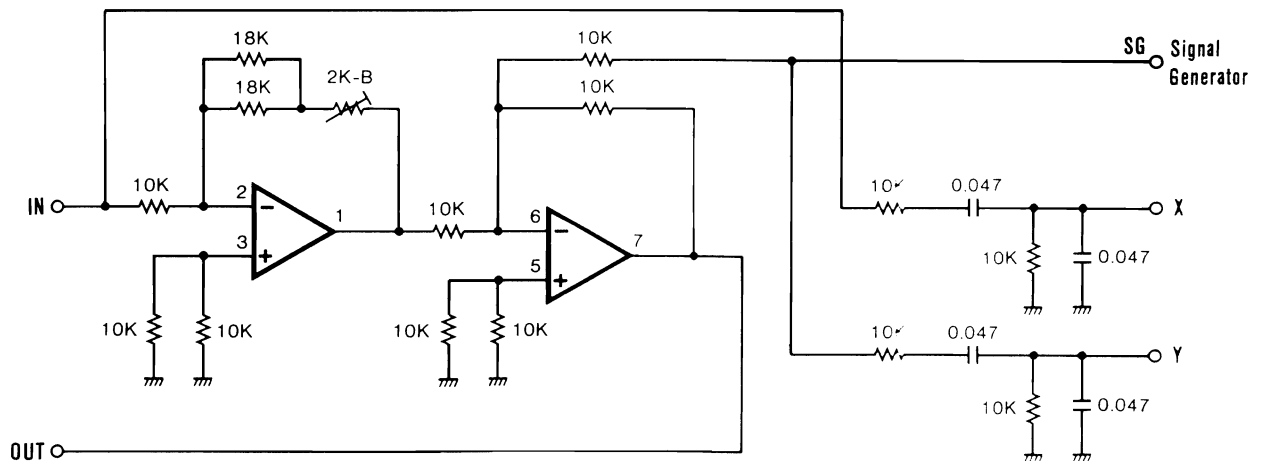

- IC LA64580 or equivalent
- In advance, adjust the semi-fixed volume (2K-B) for the minimum output at the OUT, by shorting across IN and SG, and by applying 1kHz, 1Vp-p from SG.

ADJUSTMENT PROCEDURES (Continued)

Plain Adjusting Method

- Adjustment of Focus Gain
Set the VR602 at clockwise 15° from the center point as show below.

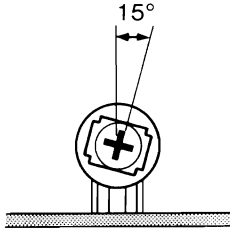

- Adjustment of Tracking Gain
Set the VR605 at counterclockwise 15° from the center point as shown below.

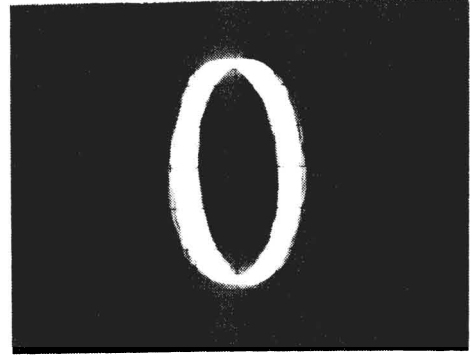
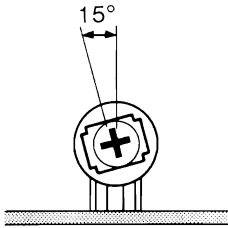

Accurate Adjusting Method

- Adjustment of Focus Gain
1. With the VR602 at the center point, load the test disc YEDS4 on the turntable.
 2. Connect the circuit for measurement shown in the item 13 to the set as follows:

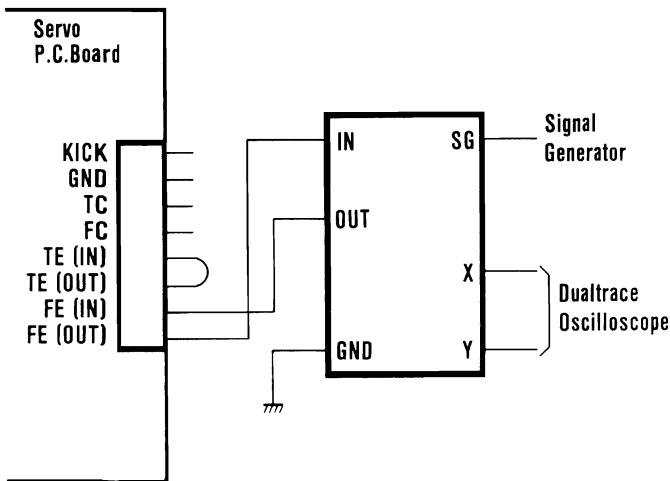

3. Turning on the power, play the first tune and apply a signal of 950Hz/0.5Vp-p from the frequency generator to the circuit for measurement.
4. Observing the Lissajous's waveforms on the oscilloscope, adjust the VR602 for getting a phase difference of 90° between the outputs on the circuit, X and Y, as follows:

Adjustment of Tracking Gain

1. Load the test disc YEDS4 on the turntable with the VR605 at the center point.
2. Connect the circuit for measurement to the set as follows:

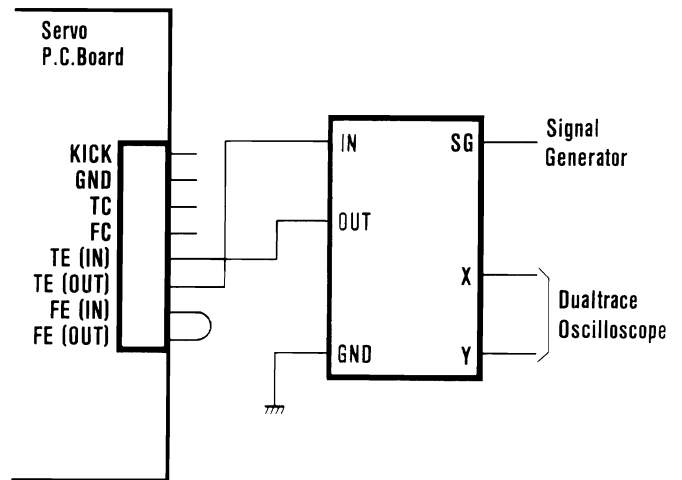

3. Turning on the power, play the first tune and apply a signal of 1300Hz/0.5vp-p from the frequency generator to the circuit for measurement.
4. Observing the Lissajous's waveforms on the oscilloscope, adjust the VR605 for getting a phase difference of 90° between the outputs on the circuit, X and Y, as follows:

ADJUSTMENT PROCEDURES (Continued)

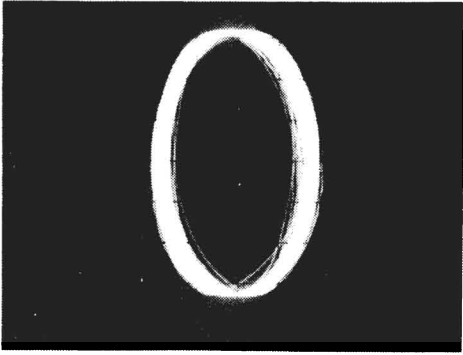

HF
1V/DIV
(50μSec/DIV)

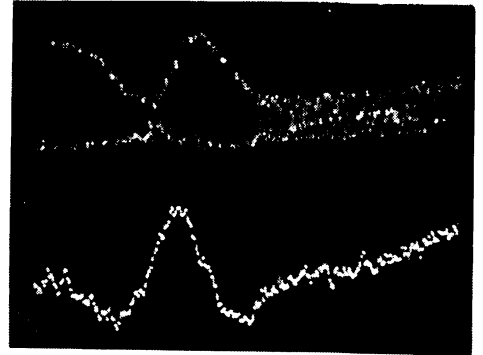

TE
0.5V/DIV
(50μSec/DIV)

14. ADJUSTMENT OF KICK GAIN

1. Load the test disc YEDS4 on the turn table.
2. Set the oscilloscope at the NORMAL TRIG. and connect the IC102 (YM3531) No. 21 Pin (TRHD) of the Main P.C.Board to the external trigger terminal. Then, connect the channels, 1 and 2, to the test points, **HF** and **TE**, respectively.
3. Switch on the power. In the state of playing the first tune, make it pause and observe the waveforms of **HF** and **TE** triggered by **TRHD**.
4. Adjust the VR606 for making a track jump between 1 and 1.5 track.

Waveform showing Excessive Kick Gain

(make it in a reasonable state by turning the VR606 clockwise.)

15. ADJUSTING DAC

1. Load the test disc YEDS7 on the turntable.
2. Connect the outlet of the set to the AUX terminal of the premain amplifier. Also connect the speaker output of the amplifier to the oscilloscope.
3. Turn on the power. In playing the twenty-first tune apply a reasonable output to the oscilloscope with the volume knob of the premain amplifier.
4. Adjust the VR101 for getting sine waveforms on the oscilloscope.

HF
1V/DIV
(50μSec/DIV)

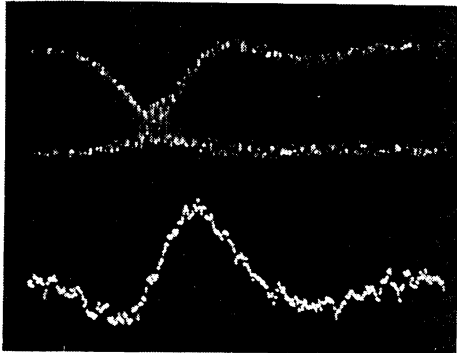

Corrected Waveform

TE
0.5V/DIV
(50μSec/DIV)

HF
1V/DIV
(50μSec/DIV)

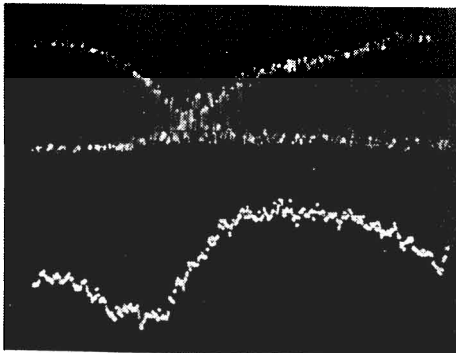

TE
0.5V/DIV
(50μSec/DIV)

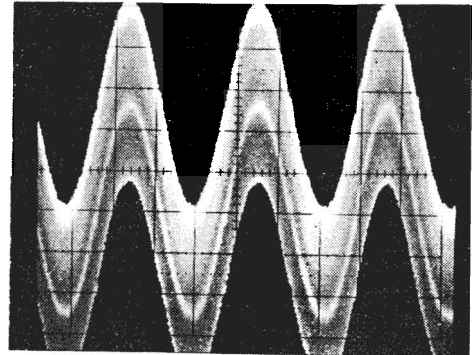

Proper Waveform

Waveform showing Short Kick Gain

(Make it in a reasonable state by turning the VR606 counterclockwise.)

ADJUSTMENT PROCEDURES (Continued)

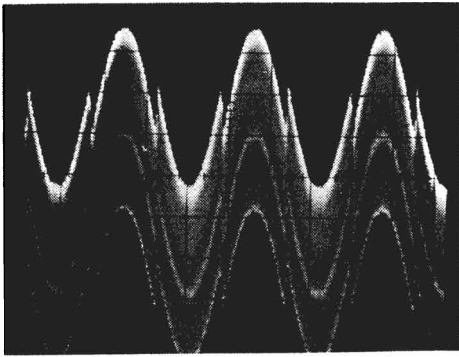

Interrupted Waveform

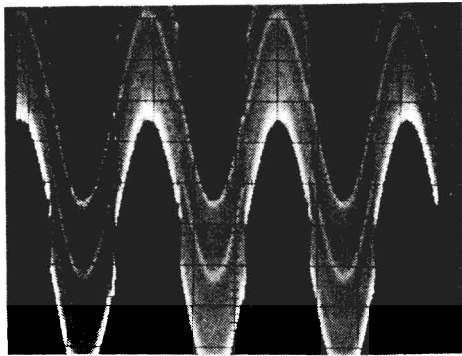

Interrupted Waveform

P.C.BOARD ALIGNMENT POINTS

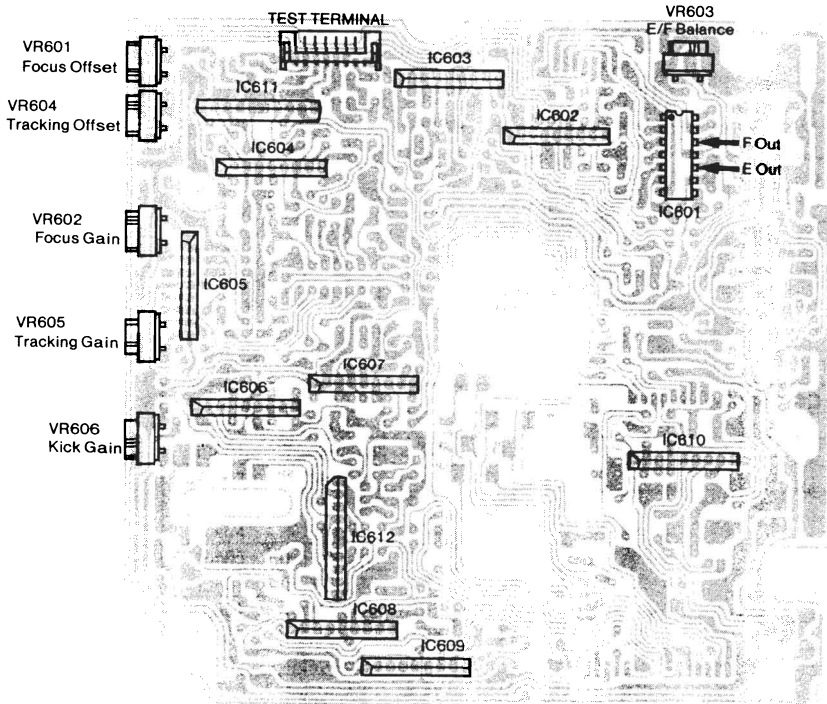
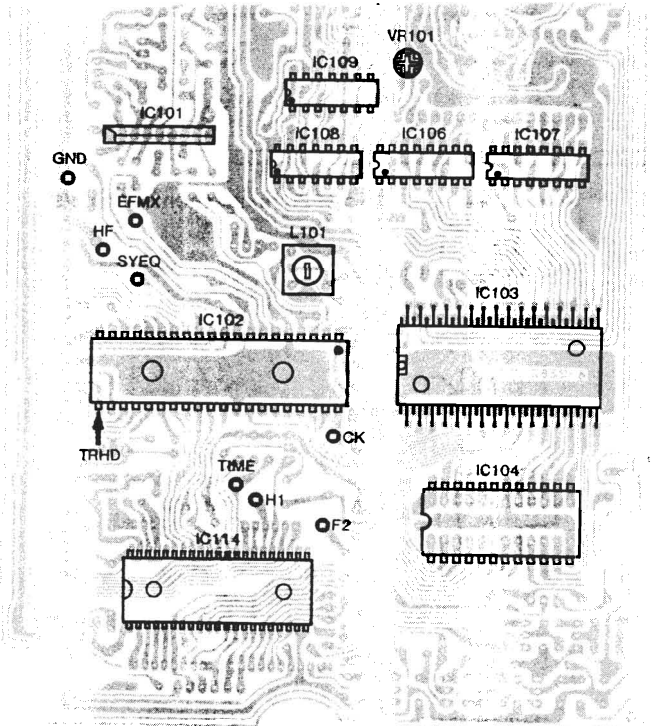
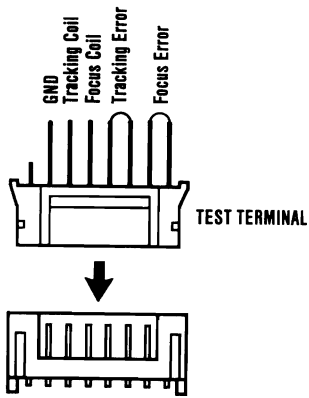

INSTALLATION METHOD FOR EACH LEAF SWITCH

• Table Load Switch

With the table load in the open condition, fix the switch as in the diagram so that the tip of the leaf switch is positioned in the center of the lever rock notch.

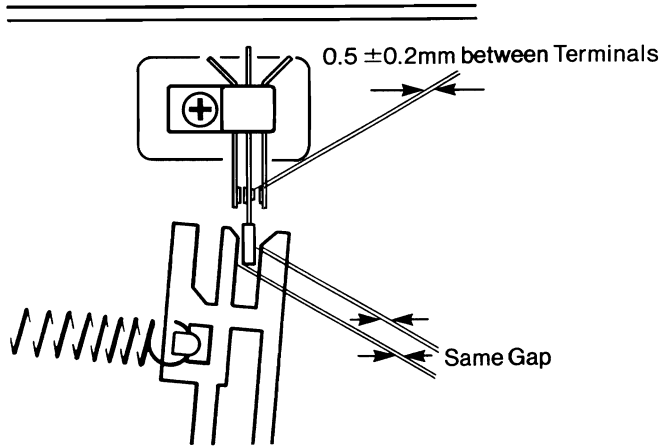

Set the space between the left and right terminals of the leaf switch to $0.5 \pm 0.2\text{mm}$.

• Pickup Switch

As in the diagram, install level with the chassis.

Set a space of $0.5 \pm 0.2\text{mm}$ between the upper and lower switch terminals.

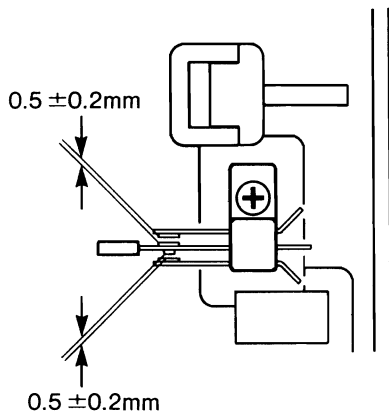

• Eject Switch

Install so that the tip of the leaf switch and the slide eject are contacting, as shown in the diagram.

Set a space of 0.2 to 0.5mm between the terminals of the switch.

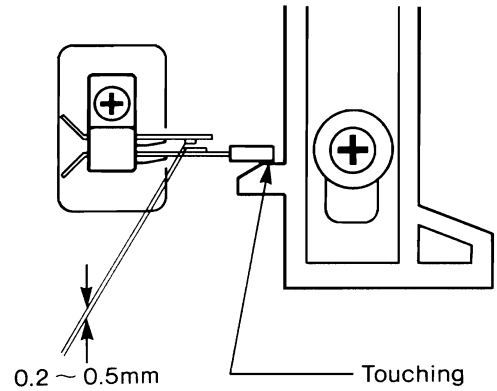

INPUT PORT ASSIGNMENTS (MICRO PROCESSOR UNIT IC114)

OUTPUT PORT ASSIGNMENTS (MICRO PROCESSOR UNIT IC114)

Pin No.	Port Name	Command Name
6	$\overline{\text{INT}}$	$\overline{\text{Stope Switch}}$
26	PH0	} Key Scan
27	PH1	
28	PH2	
29	PH3	
31	PI1	} Key Scan
32	PI2	} (Open/Close)
35	PA2	} IC 102
37	PB0	

NOTE:

The signals with lines drawn above their names show that they are active in low level.

Pin No.	Port Name	Command Name
2	PC0	$\overline{\text{PLAY Indicator}}$
3	PC1	$\overline{\text{PAUSE Indicator}}$
4	PC2	$\overline{\text{ALL Indicator}}$
5	PC3	$\overline{\text{ONE Indicator}}$
8	PD0	$\overline{\text{DP2 Display LED}}$
11	PD3	Digit Change
12	PE0	} $\overline{\text{A}}$ $\overline{\text{B}}$ $\overline{\text{C}}$ $\overline{\text{D}}$ $\overline{\text{E}}$ $\overline{\text{F}}$ $\overline{\text{G}}$ Display LED
13	PE1	
14	PE2	
15	PE3	
16	PF0	
17	PF1	
18	PF2	
19	PF3	$\overline{\text{DP1 Display LED}}$
22	PG0	Lid Open
23	PG1	Lid Close
24	PG2	} Key Scan
25	PG3	
33	PA0	} IC 102
34	PA1	
36	PI2	
38	PI2	Laser

Segment Position

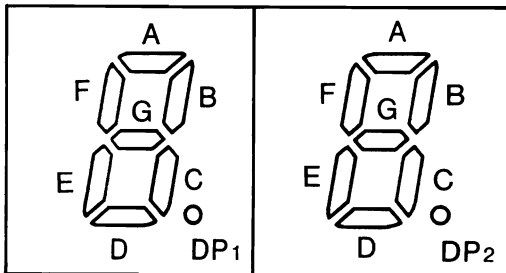

SERVO P.C.BOARD

(BOTTOM VIEW)

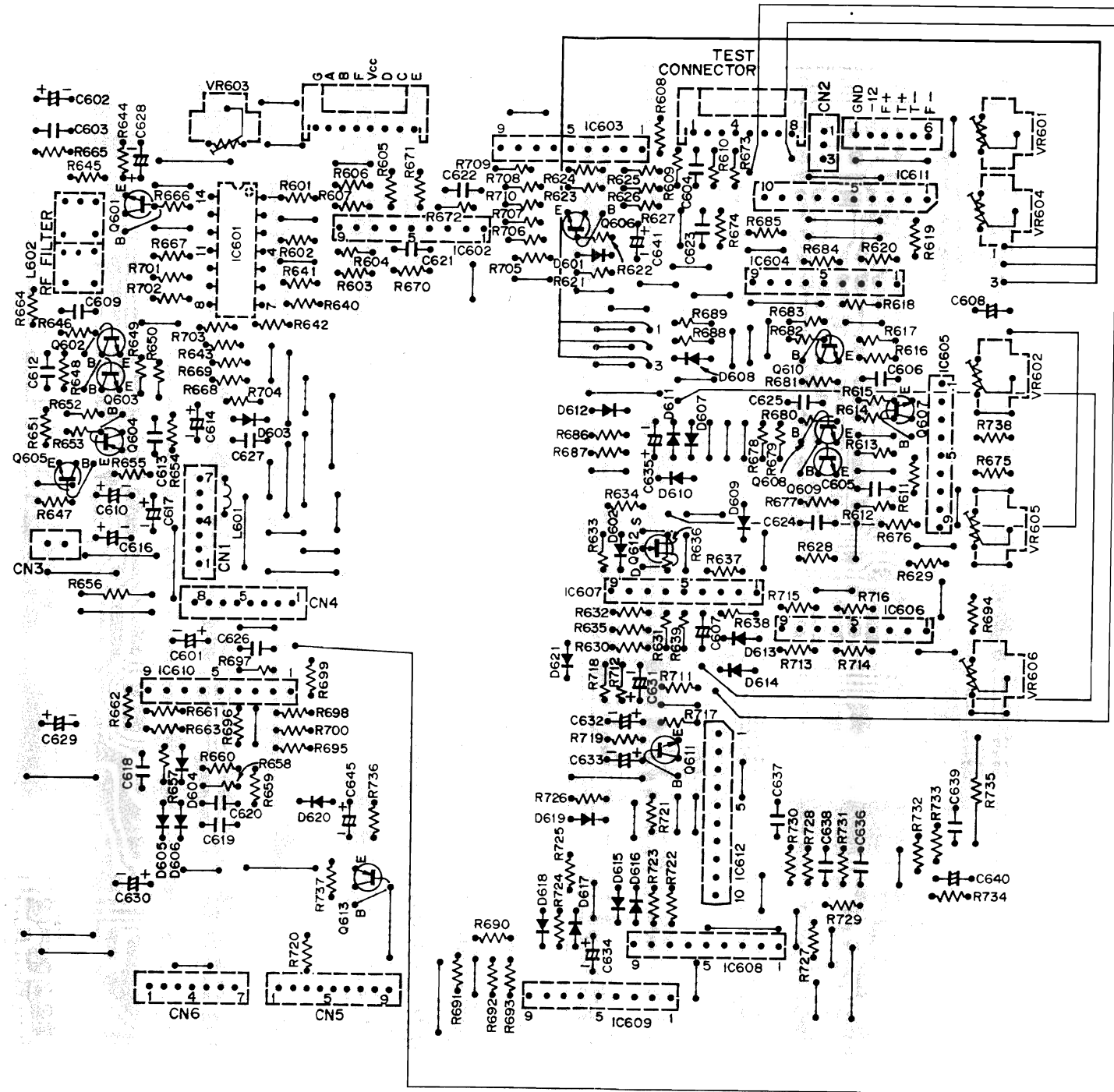

IC PIN NUMBERS DC VOLTAGES															
SYMBOL No.	DEVICE	1	2	3	4	5	6	7	8	9	10	11	12	13	14
IC601	TC40H004P	2.3V	2.3V	2.3V	2.3V	2.3V	2.3V	2.3V	0V	2.3V	2.3V	2.3V	2.3V	2.3V	4.9V
IC602	NJM4558S	12.8V	0V	2.1V	2.1V	-12.9V	0V	0V	0V	12.8V					
IC603	NJM4558S	12.8V	12.0V	0V	0V	-13.0V	2.2V	3.0V	-11.4V	12.8V					
IC604	NJM4558S	12.9V	1.7V	0V	0V	-13.0V	0V	0V	0V	12.9V					
IC605	NJM4558S	12.9V	0.2V	0V	0V	-13.0V	0V	0V	0V	12.9V					
IC606	NJM4558S	12.9V	-11.7V	0V	-0.4V	-13.0V	0V	0.4V	-11.7V	12.9V					
IC607	NJM4558S	12.9V	-11.7V	0.3V	-0.4V	-13.0V	3.1V	0V	-12.3V	12.9V					
IC608	NJM4558S	12.9V	-0.3V	0V	0V	-13.0V	0V	0V	0.3V	12.9V					
IC609	NJM4558S	12.9V	-	-	-	-13.0V	0V	0V	0V	12.9V					
IC610	NJM4558S	12.9V	-12.9V	0V	-0.2V	-13.0V	0V	0V	-3.8V	12.9V					
IC611	STA451C	-0.9V	13.0V	-1.4V	0V	-0.5V	-0.5V	0V	-1.4V	-13.0V	-0.8V				
IC612	STA451C	0V	12.9V	0.3V	0V	-0.3V	-0.3V	0V	0.3V	-13.0V	0V				

TRANSISTOR DC VOLTAGES									
SYMBOL No.	DEVICE	B	C	E	SYMBOL No.	DEVICE	B	C	E
Q601	2SC536	2.3V	4.8V	1.7V	Q608	2SD1012	0V	0V	0V
Q602	2SC536	0V	12.3V	-0.6V	Q609	2SD1012	0.6V	0V	0V
Q603	2SC536	0V	10.9V	-0.6V	Q610	2SD1012	0V	0V	0V
Q604	2SA608	10.7V	2.4V	11.3V	Q611	2SD1012	0.6V	0V	0V
Q605	2SC536	2.4V	12.9V	1.7V	Q613	2SA608	4.8V	4.8V	0V
Q606	2SD1012	-7.8V	0V	0V			G	D	S
Q607	2SD1012	-1.1V	0.1V	0V	Q612	2SK246	0.4V	0.4V	0.4V

MAIN P.C. BOARD (BOTTOM VIEW)

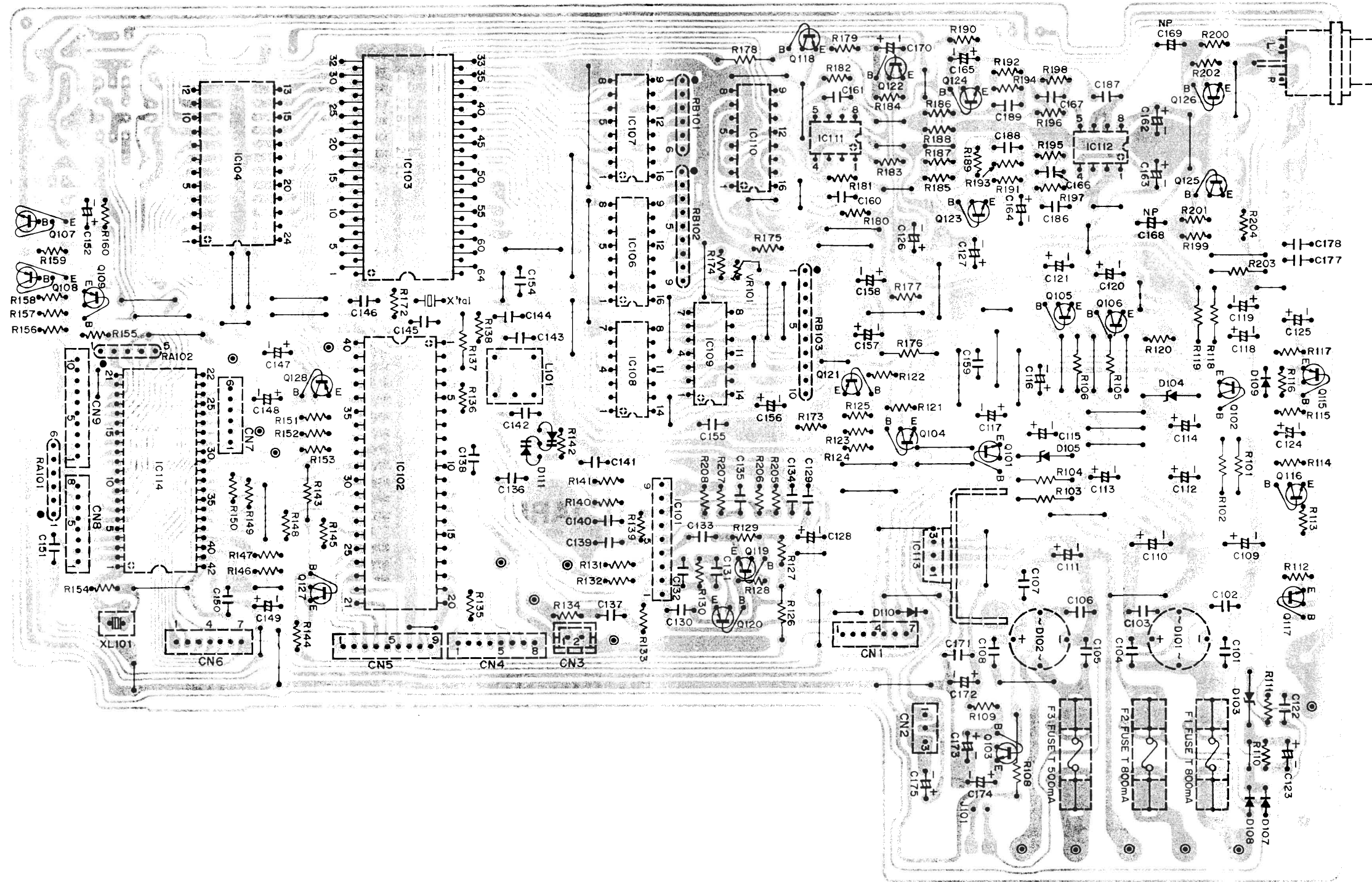

IC PIN NUMBERS DC VOLTAGES

SYMBOL No.	DEVICE	1	2	3	4	5	6	7	8	9	10	11	12	13	14	15	16	17	18	19	20
IC101	NJM2043S	12.9V	2.0V	2.0V	2.0V	-13.0V	2.4V	2.4V	2.5V	12.8V											
IC110	MSM4053RS	0V	0V	0V	0V	0V	-6.0V	0V	0.9V	0.9V	1.9V	0V	0V	0V	0V	4.8V					
IC111	LM833N	0.6V	0V	0V	-10.3V	0V	0V	0.6V	10.3V												
IC112	NJM4558D	0.6V	0.6V	0.6V	-10.3V	0.6V	0.6V	10.3V													
IC114	LM6402H	2.4V	4.9V	4.9V	4.9V	4.9V	4.9V	4.9V	4.9V	4.9V	2.5V	4.9V	2.6V	2.6V	4.9V	4.9V	4.9V	4.9V	4.9V	0V	
		21	22	23	24	25	26	27	28	29	30	31	32	33	34	35	36	37	38	39	40
		0V	0V	0V	3.5V	1.7V	4.9V	4.9V	4.9V	4.9V	1.7V	2.2V	4.9V	0V	4.9V	0V	0V	4.9V	4.9V	4.9V	
		41	42																		
		4.9V	2.4V																		

TRANSISTOR DC VOLTAGES

SYMBOL No.	DEVICE	B	C	E	SYMBOL No.	DEVICE	B	C	E
Q101	2SD612	13.6V	18.0V	12.9V	Q117	2SC536	0.6V	0V	0V
Q102	2S8511	-13.0V	-17.3V	-13.6V	Q118	2SC536	0V	10.1V	0V
Q103	2SD734	4.8V	9.1V	4.2V	Q119	2SC536	0V	1.6V	0V
Q104	2SD734	-13.0V	-0.4V	-13.0V	Q120	2SA608	1.7V	1.8V	2.0V
Q105	2SD734	13.4V	17.8V	12.7V	Q121	2SA608	4.9V	-13.0V	4.9V
Q106	2SB698	-13.4V	-17.3V	-12.8V	Q122	2SA608	10.2V	-7.8V	10.3V
Q107	2SC536	0V	4.8V	0V	Q123,124	2SD1012	-7.7V	0V	0V
Q108	2SA608	3.8V	2.1V	4.2V	Q125,126	2SD1012	-7.7V	0V	0V
Q109	2SA608	4.2V	2.8V	4.2V	Q127	2SD1012	-0.4V	0V	0V
Q115	2SA608	4.7V	-7.8V	4.8V	Q128	2SA1345	4.9V	4.9V	0V
Q116	2SC536	0V	4.8V	0V					

DISK IND. P.C. BOARD (BOTTOM VIEW)

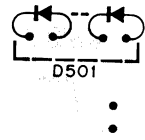

POWER SWITCH P.C. BOARD (BOTTOM VIEW)

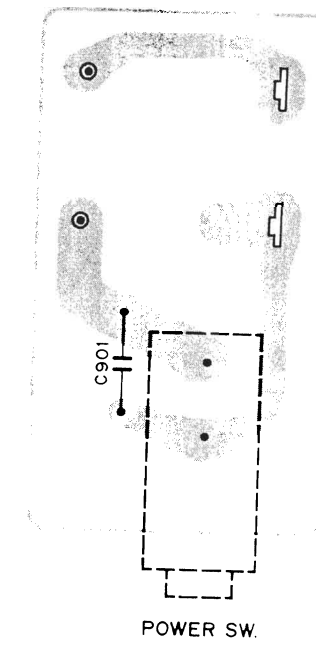

CONTROL P.C. BOARD (BOTTOM VIEW)

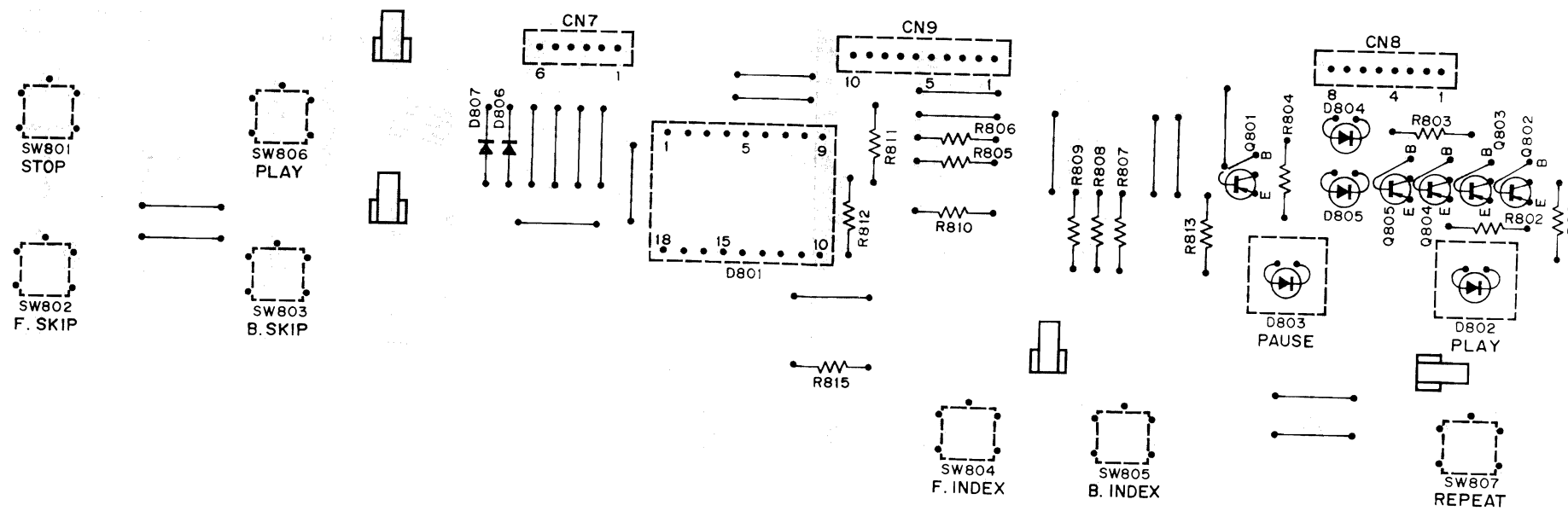

P.C.BOARD PARTS LIST

Ref. No.	Part No.	Description	Q'ty	Ref. No.	Part No.	Description	Q'ty
MAIN P.C.B. ASSY							
PCB1	141-0-1939-08262	Main P.C.B. Assy	1	Q121	203-5-7230-60850	Transistor, 2SA 608	1
	4-2352-01631	Pin Jack 2P	1	Q122	203-5-7230-60850	Transistor, 2SA 608	1
	4-2369-73783	Pin 1P	1	Q123	203-5-4921-01270	Transistor, 2SD 1012	1
	△ 4-2352-01940	Fuse Clip	6	Q124	203-5-4921-01270	Transistor, 2SD 1012	1
	111-2-6220-11100	Wire Wrap Terminal	13	Q125	203-5-4920-01270	Transistor, 2SD 1012	1
	131-2-6201-30100	Plate Heat Sink (for IC113)	1	Q126	203-5-4920-01270	Transistor, 2SD 1012	1
	141-2-3229-43300	Cover Shield	1	Q127	203-5-4920-01270	Transistor, 2SD 1012	1
	143-3-1903-00611	Screw, Brazier Hd. Tapping-B, +M3.0x6	1	Q128	203-5-1220-34510	Transistor, 2SA 1345	1
	131-2-9800-01835	Jumper	1	C101	CC1-0-3500-ZG00C	Ceramic 0.01μF 50V +80.-20%	1
CN1	4-2369-75040	Plug 7P	1	C102	CC1-0-3500-ZG00C	Ceramic 0.01μF 50V +80.-20%	1
CN2	4-2369-75020	Plug 3P	1	C103	CC1-0-3500-ZG00C	Ceramic 0.01μF 50V +80.-20%	1
CN3	4-2362-00770	Plug 2P	1	C104	CC1-0-3500-ZG00C	Ceramic 0.01μF 50V +80.-20%	1
CN4	4-2369-75050	Plug 8P	1	C105	CC1-0-3500-ZG00C	Ceramic 0.01μF 50V +80.-20%	1
CN5	4-2369-75060	Plug 9P	1	C106	CC1-0-3500-ZG00C	Ceramic 0.01μF 50V +80.-20%	1
CN6	4-2369-75040	Plug 7P	1	C107	CC1-0-3500-ZG00C	Ceramic 0.01μF 50V +80.-20%	1
CN7	4-2369-75030	Plug 6P	1	C108	CC1-0-3500-ZG00C	Ceramic 0.01μF 50V +80.-20%	1
CN8	4-2369-75050	Plug 8P	1	C109	CD2-2-8250-0006V	Electrolytic 2200μF 25V	1
CN9	4-2369-75070	Plug 10P	1	C110	CD2-2-8250-0006V	Electrolytic 2200μF 25V	1
F1	△ 4-2349-20310	Fuse (T 500mA)	1	C111	CD2-2-8160-0006V	Electrolytic 2200μF 16V	1
F2	△ 4-2349-21540	Fuse (T 800mA)	1	C112	CD2-2-7250-0006V	Electrolytic 220μF 25V	1
F3	△ 4-2349-21540	Fuse (T 800mA)	1	C113	CD2-2-7250-0006V	Electrolytic 220μF 25V	1
XL101	4-2259-70780	CSB 800K	1	C114	CD4-7-6160-0001V	Electrolytic 47μF 16V	1
XL102	4-2259-70771	Crystal	1	C115	CD4-7-6160-0001V	Electrolytic 47μF 16V	1
L101	4-2589-72670	OSC Coil	1	C116	CD1-0-6250-0001V	Electrolytic 10μF 25V	1
VR101	4-2229-75890	Semi Fixed (B-470kΩ)	1	C117	CD1-0-6250-0001V	Electrolytic 10μF 25V	1
D101	DGG---W02--- ---	Diode, W 02	1	C118	CD1-0-6250-0001V	Electrolytic 10μF 25V	1
D102	DGG---W02--- ---	Diode, W 02	1	C119	CD1-0-6250-0001V	Electrolytic 10μF 25V	1
D103	202-5-3210-08212	Zener Diode, GZA8.2Y	1	C120	CD1-0-7160-0001V	Electrolytic 100μF 16V	1
D104	202-5-3210-13012	Zener Diode, GZA 13Y	1	C121	CD1-0-7160-0001V	Electrolytic 100μF 16V	1
D105	202-5-3210-13012	Zener Diode, GZA 13Y	1	C122	CC1-0-3500-ZG00C	Ceramic 0.01μF 50V +80.-20%	1
D107	202-5-1410-00110	Diode, GMA 01	1	C123	CD1-0-5500-0001V	Electrolytic 1μF 50V	1
D108	202-5-1410-00110	Diode, GMA 01	1	C124	CD1-0-6250-0001V	Electrolytic 10μF 25V	1
D109	202-5-1410-00110	Diode, GMA 01	1	C125	CD3-3-763A-0006V	Electrolytic 330μF 6.3V	1
D110	202-5-1410-00110	Diode, GMA 01	1	C126	CD4-7-7160-0006V	Electrolytic 470μF 16V	1
D111	202-5-1250-21110	Diode, SVC 211 SP	1	C127	CD4-7-7160-0006V	Electrolytic 470μF 16V	1
IC101	4-2069-73450	IC, NJM 2043 S	1	C128	CD1-0-6250-0001V	Electrolytic 10μF 25V	1
IC102	4-2069-73960	IC, YM 3531 SVC	1	C129	CC2-2-3500-ZG00C	Ceramic 0.022μF 50V +80.-20%	1
IC103	4-2069-73550	IC, YM 2201 SGP	1	C130	CC2-2-3500-ZG00C	Ceramic 0.022μF 50V +80.-20%	1
IC104	4-2069-73480	IC, μPD 4016 CX	1	C131	CM1-0-4500-J00TV	Mylar 0.1μF 50V ±5%	1
IC106	206-5-7854-05010	IC, LC 4050 B	1	C132	CM1-0-2500-K00SV	Mylar 0.001μF 50V ±10%	1
IC107	206-5-7854-05010	IC, LC 4050 B	1	C133	CM1-0-4500-J00TV	Mylar 0.1μF 50V ±5%	1
IC108	4-2069-74850	IC, TC 74 HC 32	1	C134	CC4-7-3500-ZG00C	Ceramic 0.047μF 50V +80.-20%	1
IC109	4-2069-74840	IC, TC 74 HC 08	1	C135	CM3-3-2500-K00SV	Mylar 0.0033μF 50V ±10%	1
IC110	4-2069-72640	IC, MSM 4053 RS	1	C136	CC1-0-1500-JD00C	Ceramic 100pF 50V ±5%	1
IC111	4-2069-72430	IC, LM 833 N	1	C137	CM1-0-4500-J00TV	Mylar 0.1μF 50V ±5%	1
IC112	IJJ---NJM4-558DX	IC, NJM 4558 DX	1	C138	CC1-5-1500-JD00C	Ceramic 150pF 50V ±5%	1
IC113	206-5-2040-07805	IC, L 78 M 05	1	C139	CC2-2-1500-KD00C	Ceramic 220pF 50V ±10%	1
IC114	208-5-7716-40246	IC, LM 6402 H 462	1	C140	CC4-7-1500-KD00C	Ceramic 470pF 50V ±10%	1
Q101	203-5-7330-61250	Transistor, 2SD 612	1	C141	CS4-7-1500-J000V	Polystyroul 470pF 50V ±5%	1
Q102	203-5-8520-51150	Transistor, 2SB 511	1	C142	CM1-0-3500-J00SV	Mylar 0.01μF 50V ±5%	1
Q103	203-5-4570-73452	Transistor, 2SD 734	1	C143	CC4-7-3500-ZG00C	Ceramic 0.047μF 50V +80.-20%	1
Q104	203-5-4570-73452	Transistor, 2SD 734	1	C144	CC4-7-3500-ZG00C	Ceramic 0.047μF 50V +80.-20%	1
Q105	203-5-4570-73452	Transistor, 2SD 734	1	C145	CC3-0-0500-JCH0C	Ceramic 30pF 50V ±5%	1
Q106	203-5-4580-69850	Transistor, 2SB 698	1	C146	CC3-0-0500-JCH0C	Ceramic 30pF 50V ±5%	1
Q107	203-5-5000-53650	Transistor, 2SC 536	1	C147	CD2-2-763A-0001V	Electrolytic 220μF 6.3V	1
Q108	203-5-7230-60850	Transistor, 2SA 608	1	C148	CD1-0-5500-0001V	Electrolytic 1μF 50V	1
Q109	203-5-7230-60850	Transistor, 2SA 608	1	C149	CD1-0-6160-0001V	Electrolytic 10μF 16V	1
Q115	203-5-7230-60850	Transistor, 2SA 608	1	C150	CS2-2-1500-J000V	Polystyroul 220pF 50V ±5%	1
Q116	203-5-5000-53650	Transistor, 2SC 536	1	C151	CS2-2-1500-J000V	Polystyroul 220pF 50V ±5%	1
Q117	203-5-5000-53650	Transistor, 2SC 536	1	C152	CD3-3-6160-0001V	Electrolytic 33μF 16V	1
Q118	203-5-5000-53650	Transistor, 2SC 536	1	C154	CC4-7-3500-ZG00C	Ceramic 0.047μF 50V +80.-20%	1
Q119	203-5-5000-53650	Transistor, 2SC 536	1	C155	CC1-0-3500-ZG00C	Ceramic 0.01μF 50V +80.-20%	1
Q120	203-5-7230-60850	Transistor, 2SA 608	1	C156	CD1-0-863A-0006V	Electrolytic 1000μF 6.3V	1
				C157	CD1-0-6250-0001V	Electrolytic 10μF 25V	1

P.C.BOARD PARTS LIST (Continued)

Ref. No.	Part No.	Description	Q'ty	Ref. No.	Part No.	Description	Q'ty
C158	CD1-0-6250-0001V	Electrolytic	10μF 25V	1	R142	RD2-2-3161-JH000	Carbon 22kΩ 1/6W ±5% 1
C159	CC1-0-3500-ZG00C	Ceramic	0.01μF 50V +80,-20%	1	R143	RD1-0-3251-JM000	Carbon 10kΩ 1/4W ±5% 1
C160	CC6-8-0500-JD01R	Ceramic	68pF 50V ±5%	1	R144	RD1-0-3161-JH000	Carbon 10kΩ 1/6W ±5% 1
C161	CC6-8-0500-JD01R	Ceramic	68pF 50V ±5%	1	R145	RD1-5-3161-JH000	Carbon 15kΩ 1/6W ±5% 1
C162	CD1-0-7160-0001V	Electrolytic	100μF 16V	1	R146	RD1-0-3161-JH000	Carbon 10kΩ 1/6W ±5% 1
C163	CD1-0-7160-0001V	Electrolytic	100μF 16V	1	R147	RD1-0-3161-JH000	Carbon 10kΩ 1/6W ±5% 1
C164	CD4-7-6250-0001V	Electrolytic	47μF 25V	1	R148	RD1-0-3161-JH000	Carbon 10kΩ 1/6W ±5% 1
C165	CD4-7-6250-0001V	Electrolytic	47μF 25V	1	R149	RD1-0-3161-JH000	Carbon 10kΩ 1/6W ±5% 1
C166	CS2-8-2500-G000V	Polystyroul	0.0028μF 50V ±2%	1	R150	RD1-0-3161-JH000	Carbon 10kΩ 1/6W ±5% 1
C167	CS2-8-2500-G000V	Polystyroul	0.0028μF 50V ±2%	1	R151	RD1-0-3161-JH000	Carbon 10kΩ 1/6W ±5% 1
C168	CB4-7-5160-0000V	None-polar	4.7μF 16V	1	R152	RD1-0-3161-JH000	Carbon 10kΩ 1/6W ±5% 1
C169	CB4-7-5160-0000V	None-polar	4.7μF 16V	1	R153	RD1-0-3161-JH000	Carbon 10kΩ 1/6W ±5% 1
C170	CD1-0-5500-0001V	Electrolytic	1μF 50V	1	R154	RD1-0-5161-JH000	Carbon 1MΩ 1/6W ±5% 1
C171	CC1-0-3500-ZG00C	Ceramic	0.01μF 50V +80,-20%	1	R155	RD3-3-2161-JH000	Carbon 3.3kΩ 1/6W ±5% 1
C172	CD1-0-6250-0001V	Electrolytic	10μF 25V	1	R156	RD2-2-2161-JH000	Carbon 2.2kΩ 1/6W ±5% 1
C173	CD1-0-6250-0001V	Electrolytic	10μF 25V	1	R157	RD2-7-2161-JH000	Carbon 2.7kΩ 1/6W ±5% 1
C174	CD4-7-5250-0001V	Electrolytic	4.7μF 25V	1	R158	RD1-0-3161-JH000	Carbon 10kΩ 1/6W ±5% 1
C175	CD1-0-6250-0001V	Electrolytic	10μF 25V	1	R159	RD1-5-3161-JH000	Carbon 15kΩ 1/6W ±5% 1
C177	CC1-0-2500-KE00C	Ceramic	0.001μF 50V ±10%	1	R160	RD2-2-3161-JH000	Carbon 22kΩ 1/6W ±5% 1
C178	CC1-0-2500-KE00C	Ceramic	0.001μF 50V ±10%	1	R172	RD1-0-5161-JH000	Carbon 1MΩ 1/6W ±5% 1
C186	CM1-2-3500-J00TV	Mylar	0.012μF 50V ±5%	1	R173	RD4-7-1161-JH000	Carbon 470Ω 1/6W ±5% 1
C187	CM1-2-3500-J00TV	Mylar	0.012μF 50V ±5%	1	R174	RD6-8-1161-JH000	Carbon 680Ω 1/6W ±5% 1
C188	CM6-8-3500-J00TV	Mylar	0.068μF 50V ±5%	1	R175	RD4-7-2161-JH000	Carbon 4.7kΩ 1/6W ±5% 1
C189	CM6-8-3500-J00TV	Mylar	0.068μF 50V ±5%	1	R176	RD4-7-2251-JM000	Carbon 4.7kΩ 1/4W ±5% 1
R101	RF4-7-1251-JH000	Mold	470Ω 1/4W ±5%	1	R177	RD4-7-1161-JH000	Carbon 470Ω 1/6W ±5% 1
R102	RF4-7-1251-JH000	Mold	470Ω 1/4W ±5%	1	R178	RD1-0-3251-JM000	Carbon 10kΩ 1/4W ±5% 1
R103	RF4-7-1251-JH000	Mold	470Ω 1/4W ±5%	1	R179	RD1-2-3161-JH000	Carbon 12kΩ 1/6W ±5% 1
R104	RF4-7-1251-JH000	Mold	470Ω 1/4W ±5%	1	R180	RD2-7-3161-JH000	Carbon 27kΩ 1/6W ±5% 1
R105	RD1-5-2251-JM000	Carbon	1.5kΩ 1/4W ±5%	1	R181	RD8-2-2161-JH000	Carbon 8.2kΩ 1/6W ±5% 1
R106	RD1-5-2251-JM000	Carbon	1.5kΩ 1/4W ±5%	1	R182	RD8-2-2161-JH000	Carbon 8.2kΩ 1/6W ±5% 1
R108	RH8-2-1501-JZ000	Metal	820Ω 1/2W ±5%	1	R183	RD1-0-4161-JH000	Carbon 100kΩ 1/6W ±5% 1
R109	RD6-8-1161-JH000	Carbon	680Ω 1/6W ±5%	1	R184	RD1-0-4161-JH000	Carbon 100kΩ 1/6W ±5% 1
R110	RD2-2-3161-JH000	Carbon	22kΩ 1/6W ±5%	1	R185	RD4-7-1161-JH000	Carbon 470Ω 1/6W ±5% 1
R111	RD2-2-3161-JH000	Carbon	22kΩ 1/6W ±5%	1	R186	RD4-7-1161-JH000	Carbon 470Ω 1/6W ±5% 1
R112	RD1-0-3161-JH000	Carbon	10kΩ 1/6W ±5%	1	R187	RD1-0-4161-JH000	Carbon 100kΩ 1/6W ±5% 1
R113	RD1-5-3161-JH000	Carbon	15kΩ 1/6W ±5%	1	R188	RD1-0-4161-JH000	Carbon 100kΩ 1/6W ±5% 1
R114	RD1-0-0161-JH000	Carbon	10Ω 1/6W ±5%	1	R189	RD8-2-2161-JH000	Carbon 8.2kΩ 1/6W ±5% 1
R115	RD1-0-3161-JH000	Carbon	10kΩ 1/6W ±5%	1	R190	RD8-2-2161-JH000	Carbon 8.2kΩ 1/6W ±5% 1
R116	RD1-2-4161-JH000	Carbon	120kΩ 1/6W ±5%	1	R191	RD2-2-4161-JH000	Carbon 220kΩ 1/6W ±5% 1
R117	RD2-2-1161-JH000	Carbon	220Ω 1/6W ±5%	1	R192	RD2-2-4161-JH000	Carbon 220kΩ 1/6W ±5% 1
R118	RD2-7-1251-JM000	Carbon	270Ω 1/4W ±5%	1	R193	RD1-8-1161-JH000	Carbon 180Ω 1/6W ±5% 1
R119	RD2-7-1251-JM000	Carbon	270Ω 1/4W ±5%	1	R194	RD1-8-1161-JH000	Carbon 180Ω 1/6W ±5% 1
R120	RD1-0-4161-JH000	Carbon	100kΩ 1/6W ±5%	1	R195	RD6-8-1161-JH000	Carbon 680Ω 1/6W ±5% 1
R121	RD2-2-3161-JH000	Carbon	22kΩ 1/6W ±5%	1	R196	RD6-8-1161-JH000	Carbon 680Ω 1/6W ±5% 1
R122	RD2-2-2161-JH000	Carbon	2.2kΩ 1/6W ±5%	1	R197	RD8-2-1161-JH000	Carbon 820Ω 1/6W ±5% 1
R123	RD3-3-2161-JH000	Carbon	3.3kΩ 1/6W ±5%	1	R198	RD8-2-1161-JH000	Carbon 820Ω 1/6W ±5% 1
R124	RD1-0-3161-JH000	Carbon	10kΩ 1/6W ±5%	1	R199	RD1-0-2161-JH000	Carbon 1kΩ 1/6W ±5% 1
R125	RD2-2-3161-JH000	Carbon	22kΩ 1/6W ±5%	1	R200	RD1-0-2161-JH000	Carbon 1kΩ 1/6W ±5% 1
R126	RD2-2-3251-JM000	Carbon	22kΩ 1/4W ±5%	1	R201	RD1-0-4161-JH000	Carbon 100kΩ 1/6W ±5% 1
R127	RD2-2-3161-JH000	Carbon	22kΩ 1/6W ±5%	1	R202	RD1-0-4161-JH000	Carbon 100kΩ 1/6W ±5% 1
R128	RD2-2-3161-JH000	Carbon	22kΩ 1/6W ±5%	1	R203	RD6-8-2251-JM000	Carbon 6.8kΩ 1/4W ±5% 1
R129	RD2-2-3161-JH000	Carbon	22kΩ 1/6W ±5%	1	R204	RD6-8-2161-JH000	Carbon 6.8kΩ 1/6W ±5% 1
R130	RD1-0-5161-JH000	Carbon	1MΩ 1/6W ±5%	1	R205	RD2-2-3161-JH000	Carbon 22kΩ 1/6W ±5% 1
R131	RD6-8-2161-JH000	Carbon	6.8kΩ 1/6W ±5%	1	R206	RD2-2-3161-JH000	Carbon 22kΩ 1/6W ±5% 1
R132	RD6-8-2161-JH000	Carbon	6.8kΩ 1/6W ±5%	1	R207	RD4-7-2161-JH000	Carbon 4.7kΩ 1/6W ±5% 1
R133	RD1-0-3161-JH000	Carbon	10kΩ 1/6W ±5%	1	R208	RD1-0-4161-JH000	Carbon 100kΩ 1/6W ±5% 1
R134	RD4-7-1161-JH000	Carbon	470Ω 1/6W ±5%	1	RA101	4-2219-70590	RM5-103J 1
R135	RD1-0-3161-JH000	Carbon	10kΩ 1/6W ±5%	1	RA102	4-2219-71270	Resistor 1
R136	RD2-2-3161-JH000	Carbon	22kΩ 1/6W ±5%	1	RB101	4-2219-71290	Resistor 1
R137	RD2-2-3251-JM000	Carbon	22kΩ 1/4W ±5%	1	RB102	4-2219-71300	Resistor 1
R138	RD1-5-2161-JH000	Carbon	1.5kΩ 1/6W ±5%	1	RB103	4-2219-71310	Resistor 1
R139	RD3-3-2161-JH000	Carbon	3.3kΩ 1/6W ±5%	1			
R140	RD2-2-2161-JH000	Carbon	2.2kΩ 1/6W ±5%	1			
R141	RD2-2-1161-JH000	Carbon	220Ω 1/6W ±5%	1			

P.C. BOARD PARTS LIST (Continued)

Ref. No.	Part No.	Description	Q'ty	Ref. No.	Part No.	Description	Q'ty
SERVO P.C.B. ASSY				Q612	4-2039-71412	FET, 2SK 246	1
PCB2	141-0-1939-08270	Servo P.C.B. Assy	1	Q613	203-5-7230-60850	Transistor, 2SA 608	1
	4-2359-78036	Connector 8P Assy (Test)	1	C601	CD1-0-763A-0002V	Electrolytic 100 μ F 6.3V	1
	4-2369-75010	Plug 8P	2	C602	CD4-7-6160-0006V	Electrolytic 47 μ F 16V	1
	4-2539-71980	RF Filter	1	C603	CC4-7-3500-ZG00C	Ceramic 0.047 μ F 50V +80,-20%	1
	131-2-9800-01029	Jumper	1	C604	CM2-2-3500-J00TV	Mylar 0.022 μ F 50V \pm 5%	1
CN1	4-2359-77970	Connector 7P Assy	1	C605	CM2-2-4500-J00TV	Mylar 0.22 μ F 50V \pm 5%	1
CN2	4-2359-77971	Connector 3P Assy	1	C606	CM6-8-4500-J00TV	Mylar 0.68 μ F 50V \pm 5%	1
CN3	4-2359-77698	Connector 2P Assy	1	C607	CB2-2-6250-0000V	None-polar 22 μ F 25V	1
CN4	4-2359-77972	Connector 8P Assy	1	C608	CB4-7-5160-0000V	None-polar 4.7 μ F 16V	1
CN5	4-2359-77973	Connector 9P Assy	1	C609	CM1-0-4500-J00TV	Mylar 0.1 μ F 50V \pm 5%	1
CN6	4-2359-77974	Connector 7P Assy	1	C610	CD4-7-6160-0006V	Electrolytic 47 μ F 16V	1
CN7	4-2359-77981	Connector 6P Assy	1	C612	CM3-3-3500-J00TV	Mylar 0.033 μ F 50V \pm 5%	1
L601	4-2539-72010	Choke Coil (100 μ H)	1	C613	CC1-0-0500-JD01R	Ceramic 10pF 50V \pm 5%	1
VR601	4-2229-74280	Semi Fixed (B-47k Ω)	1	C614	CD4-7-6160-0006V	Electrolytic 47 μ F 16V	1
VR602	4-2229-74270	Semi Fixed (B-100k Ω)	1	C616	CD1-0-6160-0002V	Electrolytic 10 μ F 16V	1
VR603	4-2229-74241	Semi Fixed (B-47k Ω)	1	C617	CD1-0-6160-0002V	Electrolytic 10 μ F 16V	1
VR604	4-2229-74270	Semi Fixed (B-100k Ω)	1	C618	CM3-3-2500-K00SV	Mylar 0.0033 μ F 50V \pm 10%	1
VR605	4-2229-74290	Semi Fixed (B-33k Ω)	1	C619	CM3-3-3500-J00TV	Mylar 0.033 μ F 50V \pm 5%	1
VR606	4-2229-74320	Semi Fixed (B-470k Ω)	1	C620	CC3-9-1500-KE01R	Ceramic 390pF 50V \pm 10%	1
D601	202-5-1410-00110	Diode, GMA 01	1	C621	CC2-2-1500-KE01R	Ceramic 220pF 50V \pm 10%	1
D602	202-5-1410-00110	Diode, GMA 01	1	C622	CC2-2-1500-KE01R	Ceramic 220pF 50V \pm 10%	1
D603	202-5-1410-00110	Diode, GMA 01	1	C623	CM8-2-3500-J00TV	Mylar 0.082 μ F 50V \pm 5%	1
D604	202-5-1410-00110	Diode, GMA 01	1	C624	CM2-2-4500-J00TV	Mylar 0.22 μ F 50V \pm 5%	1
D605	202-5-1410-00110	Diode, GMA 01	1	C625	CM4-7-4500-J00TV	Mylar 0.47 μ F 50V \pm 5%	1
D606	202-5-1410-00110	Diode, GMA 01	1	C626	CM1-0-3500-J00TV	Mylar 0.01 μ F 50V \pm 5%	1
D607	202-5-1410-00110	Diode, GMA 01	1	C627	CM3-3-4500-J00TV	Mylar 0.33 μ F 50V \pm 5%	1
D608	202-5-1410-00110	Diode, GMA 01	1	C628	CD1-0-6160-0002V	Electrolytic 10 μ F 16V	1
D609	202-5-1410-00110	Diode, GMA 01	1	C629	CD2-2-7160-0006V	Electrolytic 220 μ F 16V	1
D610	202-5-1410-00110	Diode, GMA 01	1	C630	CD2-2-7160-0006V	Electrolytic 220 μ F 16V	1
D611	202-5-1410-00110	Diode, GMA 01	1	C631	CD1-0-6160-0002V	Electrolytic 10 μ F 16V	1
D612	202-5-1410-00110	Diode, GMA 01	1	C632	CD1-0-7100-0006V	Electrolytic 100 μ F 10V	1
D613	202-5-1410-00110	Diode, GMA 01	1	C633	CD2-2-5500-0002V	Electrolytic 2.2 μ F 50V	1
D614	202-5-1410-00110	Diode, GMA 01	1	C634	CD3-3-6160-0002V	Electrolytic 33 μ F 16V	1
D615	202-5-1410-00110	Diode, GMA 01	1	C635	CD2-2-6100-0001V	Electrolytic 22 μ F 10V	1
D616	202-5-1410-00110	Diode, GMA 01	1	C636	CM1-2-3500-J00TV	Mylar 0.012 μ F 50V \pm 5%	1
D617	202-5-1410-00110	Diode, GMA 01	1	C637	CM1-2-3500-J00TV	Mylar 0.012 μ F 50V \pm 5%	1
D618	202-5-1410-00110	Diode, GMA 01	1	C638	CM2-2-2500-K00SV	Mylar 0.0022 μ F 50V \pm 10%	1
D619	202-5-1410-00110	Diode, GMA 01	1	C639	CM2-2-2500-K00SV	Mylar 0.0022 μ F 50V \pm 10%	1
D620	202-5-1410-00110	Diode, GMA 01	1	C640	CB2-2-5250-0000V	None-polar 2.2 μ F 25V	1
D621	202-5-1410-00110	Diode, GMA 01	1	C641	CD1-0-6160-0001V	Electrolytic 10 μ F 16V	1
IC601	4-2039-71250	IC. TC 40 H 004 P	1	C645	CD1-0-763A-0002V	Electrolytic 100 μ F 6.3V	1
IC602	4-2069-74710	IC. NJM 4558 S	1	R601	RD6-8-2161-JH000	Carbon 6.8k Ω 1/6W \pm 5%	1
IC603	4-2069-74710	IC. NJM 4558 S	1	R602	RD6-8-2161-JH000	Carbon 6.8k Ω 1/6W \pm 5%	1
IC604	4-2069-74710	IC. NJM 4558 S	1	R603	RD1-0-2161-JH000	Carbon 1k Ω 1/6W \pm 5%	1
IC605	4-2069-74710	IC. NJM 4558 S	1	R604	RD1-0-2161-JH000	Carbon 1k Ω 1/6W \pm 5%	1
IC606	4-2069-74710	IC. NJM 4558 S	1	R605	RD5-6-4161-JH000	Carbon 560k Ω 1/6W \pm 5%	1
IC607	4-2069-74710	IC. NJM 4558 S	1	R606	RD5-1-3161-JH000	Carbon 51k Ω 1/6W \pm 5%	1
IC608	4-2069-74710	IC. NJM 4558 S	1	R607	RD4-7-3161-JH000	Carbon 47k Ω 1/6W \pm 5%	1
IC609	4-2069-74710	IC. NJM 4558 S	1	R608	RD1-0-3161-JH000	Carbon 10k Ω 1/6W \pm 5%	1
IC610	4-2069-74730	IC. TA 75393 S	1	R609	RD3-3-3161-JH000	Carbon 33k Ω 1/6W \pm 5%	1
IC611	4-2069-73490	IC. STA 451 C	1	R610	RD3-3-2161-JH000	Carbon 3.3k Ω 1/6W \pm 5%	1
IC612	4-2069-73490	IC. STA 451 C	1	R611	RD5-6-2161-JH000	Carbon 5.6k Ω 1/6W \pm 5%	1
Q601	203-5-5000-53650	Transistor, 2SC 536	1	R612	RD5-6-2161-JH000	Carbon 5.6k Ω 1/6W \pm 5%	1
Q602	203-5-5000-53650	Transistor, 2SC 536	1	R613	RD2-7-3161-JH000	Carbon 27k Ω 1/6W \pm 5%	1
Q603	203-5-5000-53650	Transistor, 2SC 536	1	R614	RD1-2-3161-JH000	Carbon 12k Ω 1/6W \pm 5%	1
Q604	203-5-7230-60850	Transistor, 2SA 608	1	R615	RD2-7-2161-JH000	Carbon 2.7k Ω 1/6W \pm 5%	1
Q605	203-5-5000-53650	Transistor, 2SC 536	1	R616	RD3-3-3161-JH000	Carbon 33k Ω 1/6W \pm 5%	1
Q606	203-5-4921-01260	Transistor, 2SD 1012	1	R617	RD8-2-3161-JH000	Carbon 82k Ω 1/6W \pm 5%	1
Q607	203-5-4921-01260	Transistor, 2SD 1012	1	R618	RD2-2-3161-JH000	Carbon 22k Ω 1/6W \pm 5%	1
Q608	203-5-4921-01260	Transistor, 2SD 1012	1	R619	RD2-7-4161-JH000	Carbon 270k Ω 1/6W \pm 5%	1
Q609	203-5-4921-01260	Transistor, 2SD 1012	1	R620	RD6-8-1161-JH000	Carbon 680 Ω 1/6W \pm 5%	1
Q610	203-5-4921-01260	Transistor, 2SD 1012	1	R621	RD1-8-4161-JH000	Carbon 180k Ω 1/6W \pm 5%	1
Q611	203-5-4921-01260	Transistor, 2SD 1012	1	R622	RD3-3-3161-JH000	Carbon 33k Ω 1/6W \pm 5%	1

P.C.BOARD PARTS LIST (Continued)

Ref. No.	Part No.	Description	Q'ty
SW805	4-2312-05801	Key Board Switch	1
SW806	4-2312-05801	Key Board Switch	1
SW807	4-2312-05801	Key Board Switch	1
D801	4-2029-73610	LED, SL 1283	1
D802	4-2029-72590	LED, SLF 202 B	1
D803	4-2029-72600	LED, SLF 102 B	1
D804	4-2029-73600	LED, SLP 153 B	1
D805	4-2029-73600	LED, SLP 153 B	1
D806	202-5-2810-44210	Diode, DS 442	1
D807	202-5-2810-44210	Diode, DS 442	1
Q801	4-2039-72090	Transistor, DTA 114 TF	1
Q802	4-2039-72090	Transistor, DTA 114 TF	1
Q803	4-2039-72090	Transistor, DTA 114 TF	1
Q804	4-2039-72090	Transistor, DTA 114 TF	1
Q805	4-2039-72090	Transistor, DTA 114 TF	1
R801	RD1-2-1251-JM000	Carbon 120Ω 1/4W ±5%	1
R802	RD3-3-1251-JM000	Carbon 330Ω 1/4W ±5%	1
R803	RD3-3-1251-JM000	Carbon 330Ω 1/4W ±5%	1
R804	RD3-3-1251-JM000	Carbon 330Ω 1/4W ±5%	1
R805	RD2-2-1251-JM000	Carbon 220Ω 1/4W ±5%	1
R806	RD2-2-1251-JM000	Carbon 220Ω 1/4W ±5%	1
R807	RD2-2-1251-JM000	Carbon 220Ω 1/4W ±5%	1
R808	RD2-2-1251-JM000	Carbon 220Ω 1/4W ±5%	1
R809	RD2-2-1251-JM000	Carbon 220Ω 1/4W ±5%	1
R810	RD2-2-1251-JM000	Carbon 220Ω 1/4W ±5%	1
R811	RD2-2-1251-JM000	Carbon 220Ω 1/4W ±5%	1
R812	RD2-2-1251-JM000	Carbon 220Ω 1/4W ±5%	1
R813	RD2-2-1251-JM000	Carbon 220Ω 1/4W ±5%	1
R815	RD8-2-0251-JM000	Carbon 82Ω 1/4W ±5%	1
DISK INDICATOR P.C.B. ASSY			
PCB4	141-0-1939-08320	Disk Indicator P.C.B. Assy	1
D501	4-2029-72830	LED, SLP 171 D	1
POWER SWITCH P.C.B. ASSY			
PCB5	141-0-1939-08291	Power Switch P.C.B. Assy	1
	111-2-6220-11100	Wire Wrap Terminal	2
SW901	△ 4-2312-05711	Power Switch	1
C901	△ 4-2239-70970	Capacitor 0.01μF 400V	1

NOTES:

- Parts order must contain Model Number, Part Number and Description.
- Ordering quantity of screws and resistors must be multiple of 10 pcs.

PRODUCT SAFETY NOTICE

Each precaution in this manual should be followed during servicing. Components identified with the IEC symbol Δ in the parts list and the schematic diagram designate components in which safety can be of special significance. When replacing a component identified with Δ , use only the replacement parts designated, or parts with the same ratings of resistance, wattage or voltage that are designated in the parts list in this manual. Leakage-current or resistance measurements must be made to determine that exposed parts are acceptably insulated from the supply circuit before returning the product to the customer.

SAFETY INTERLOCK

The Digital Compact Disc Player reads the disc signal by detecting the laser beam. It must be avoided for the human body to directly receive the beam. Especially human eyes are badly affected by the beam. Therefore, the unit is equipped with an interlock to prevent the unnecessary laser outputs.

The laser outputs are controlled by the injection or cutoff of the constant voltage source to the laser diode with Pin 38 of IC 114 (MSM6402H). When Pin 38 is in "L" (Low) level, the laser emits the beam. When Pin 38 is in "H" (High) level, the laser does not emit the beam.

Pin 38 is set in "H" level when the unit is loaded with the disc and it reads the index signals or when the unit is set in the play mode after that. When the unit reads the index signals and the

following two conditions are met, the laser emits the beam.

- When the Loading Limit Switch is set in "CLOSE" side. (The disc tray is closed.)
- The pickup is located at the area of the minimum internal circumference.

After the above conditions are met and the index signals have been read, the laser emits the beam when the following two conditions are met.

- When the PLAY button is pressed.
- When the PLAY indicator is ON.

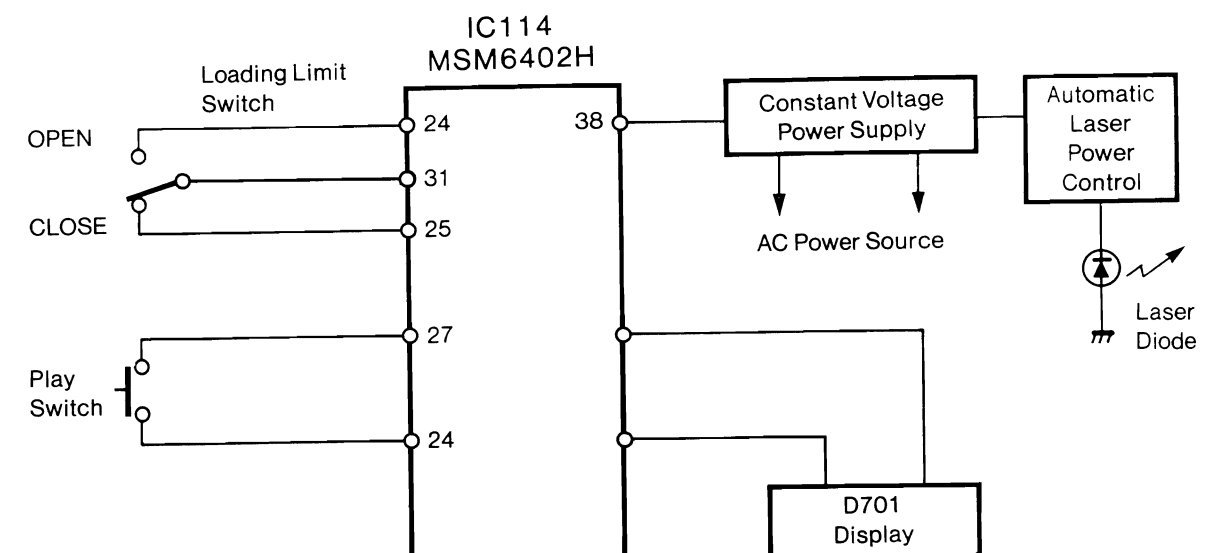

POINT TO POINT WIRING DIAGRAM

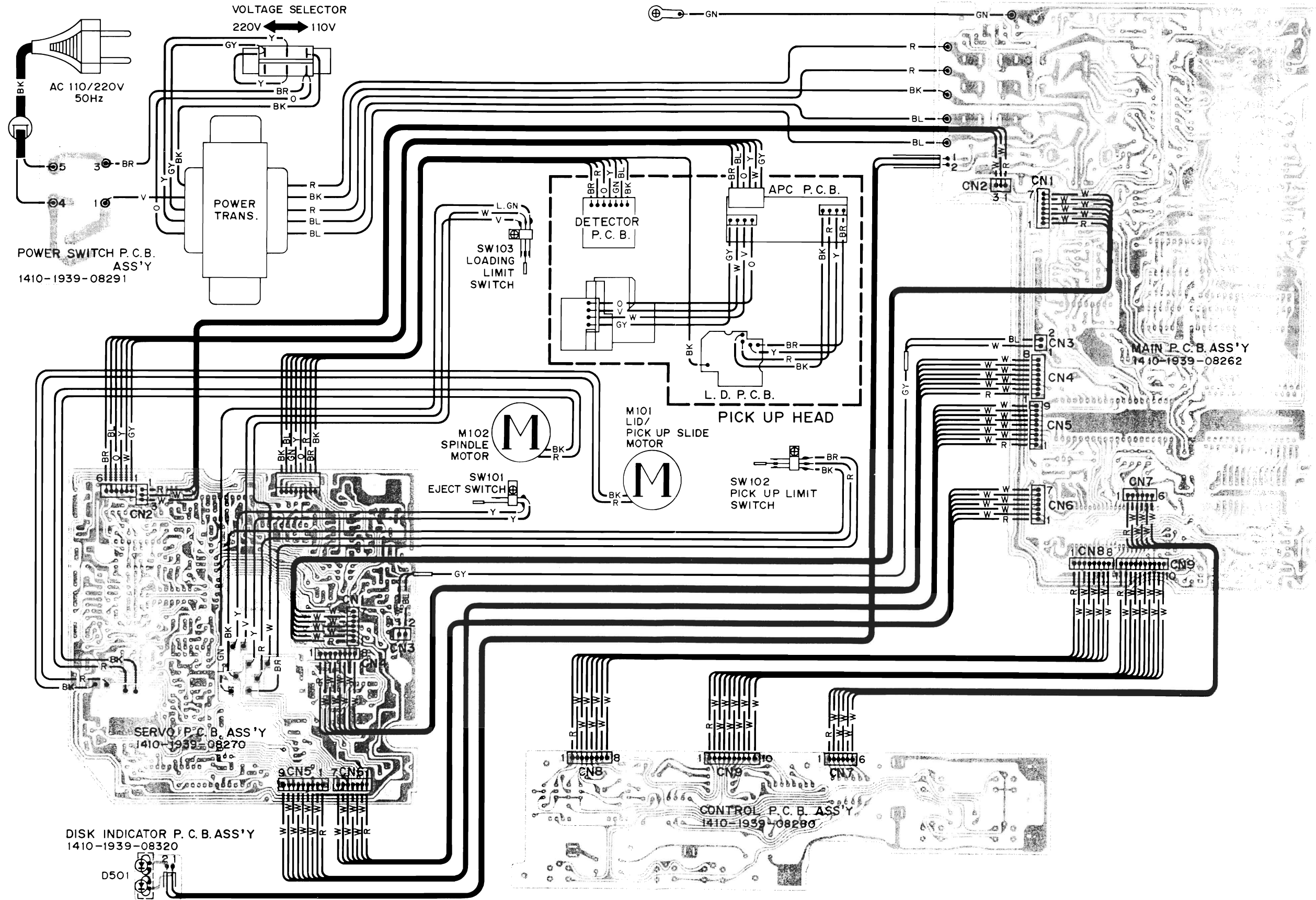

SCHEMATIC DIAGRAM

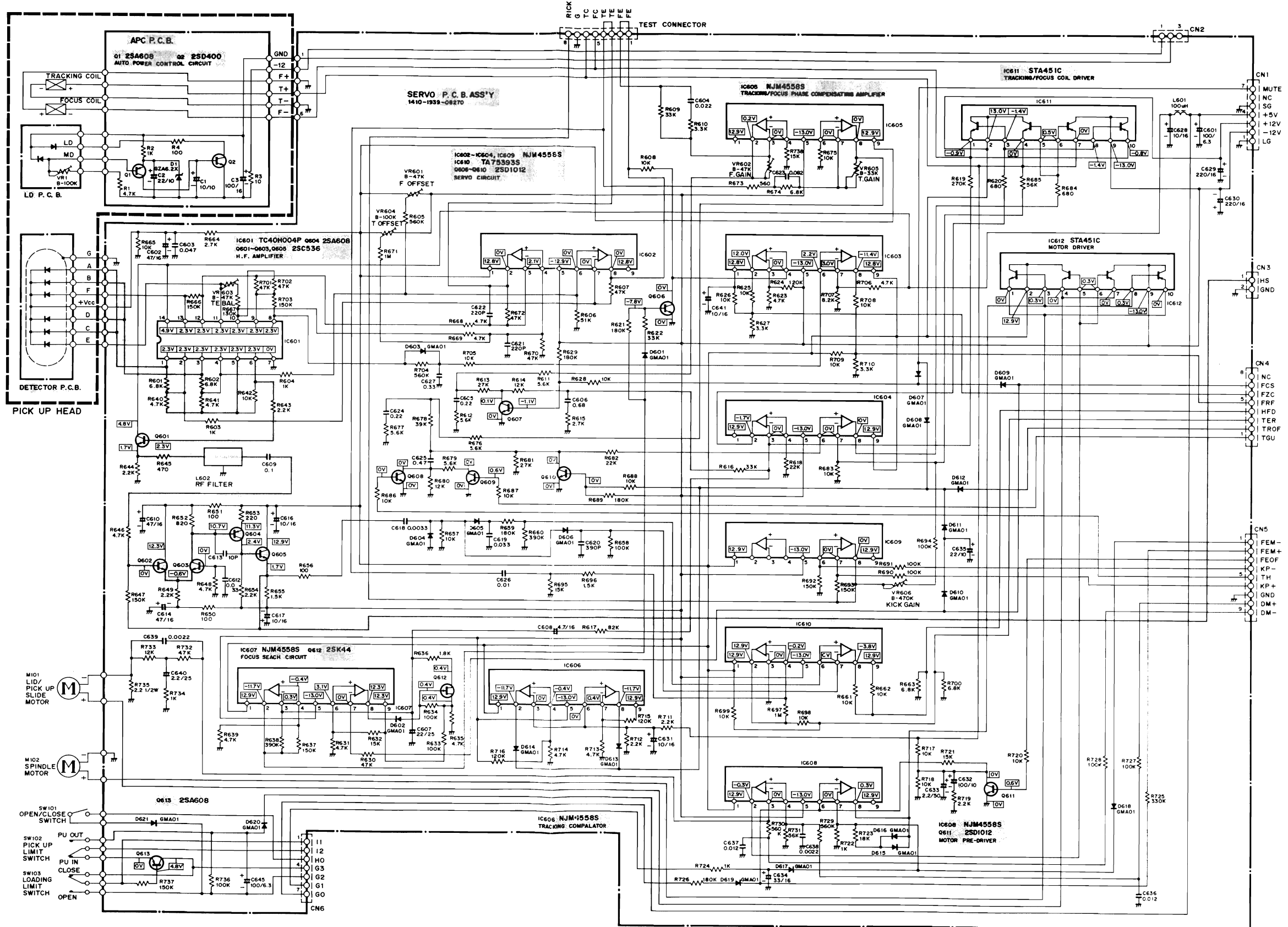

SCHEMATIC DIAGRAM (Continued)

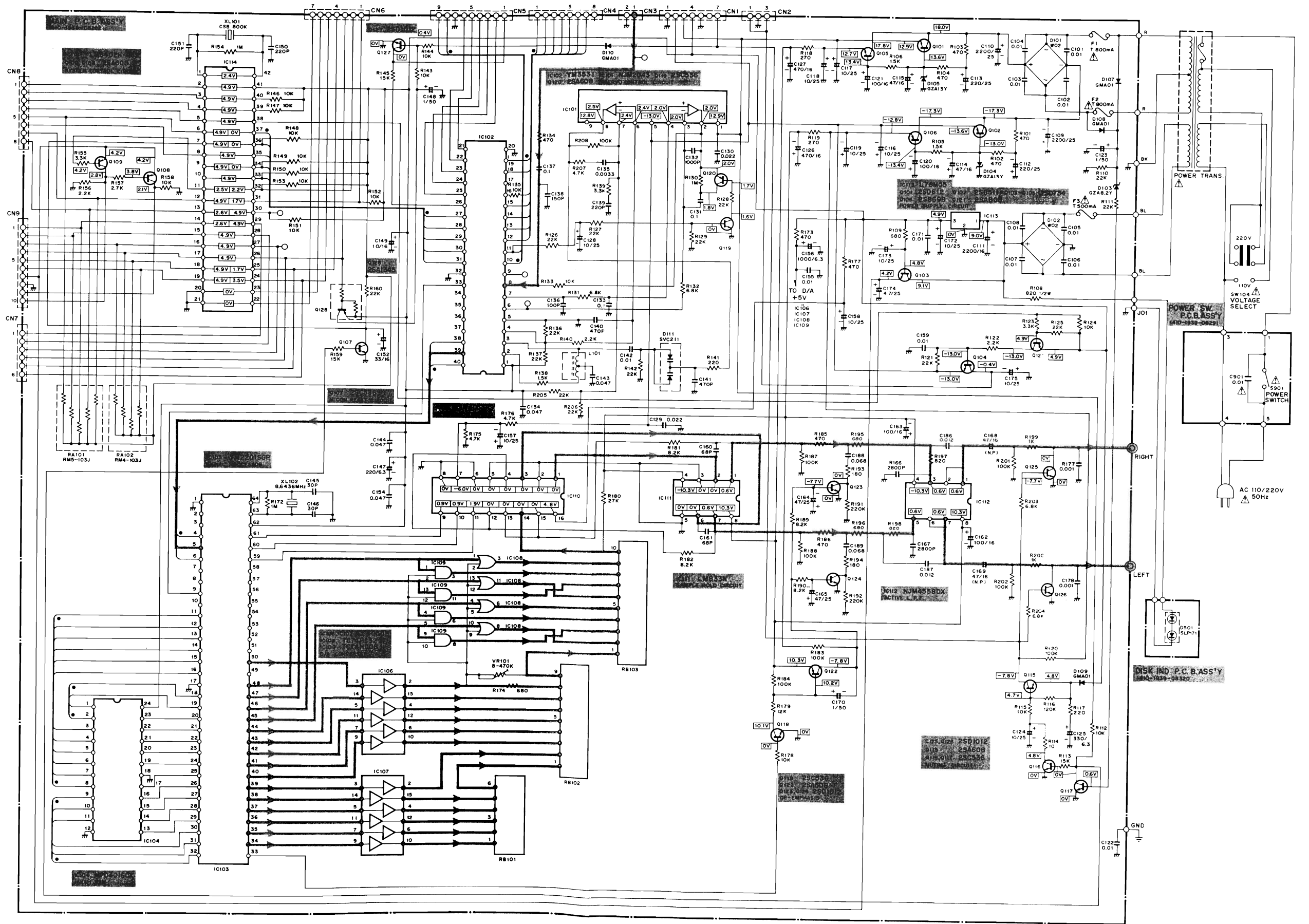

SCHEMATIC DIAGRAM (Continued)

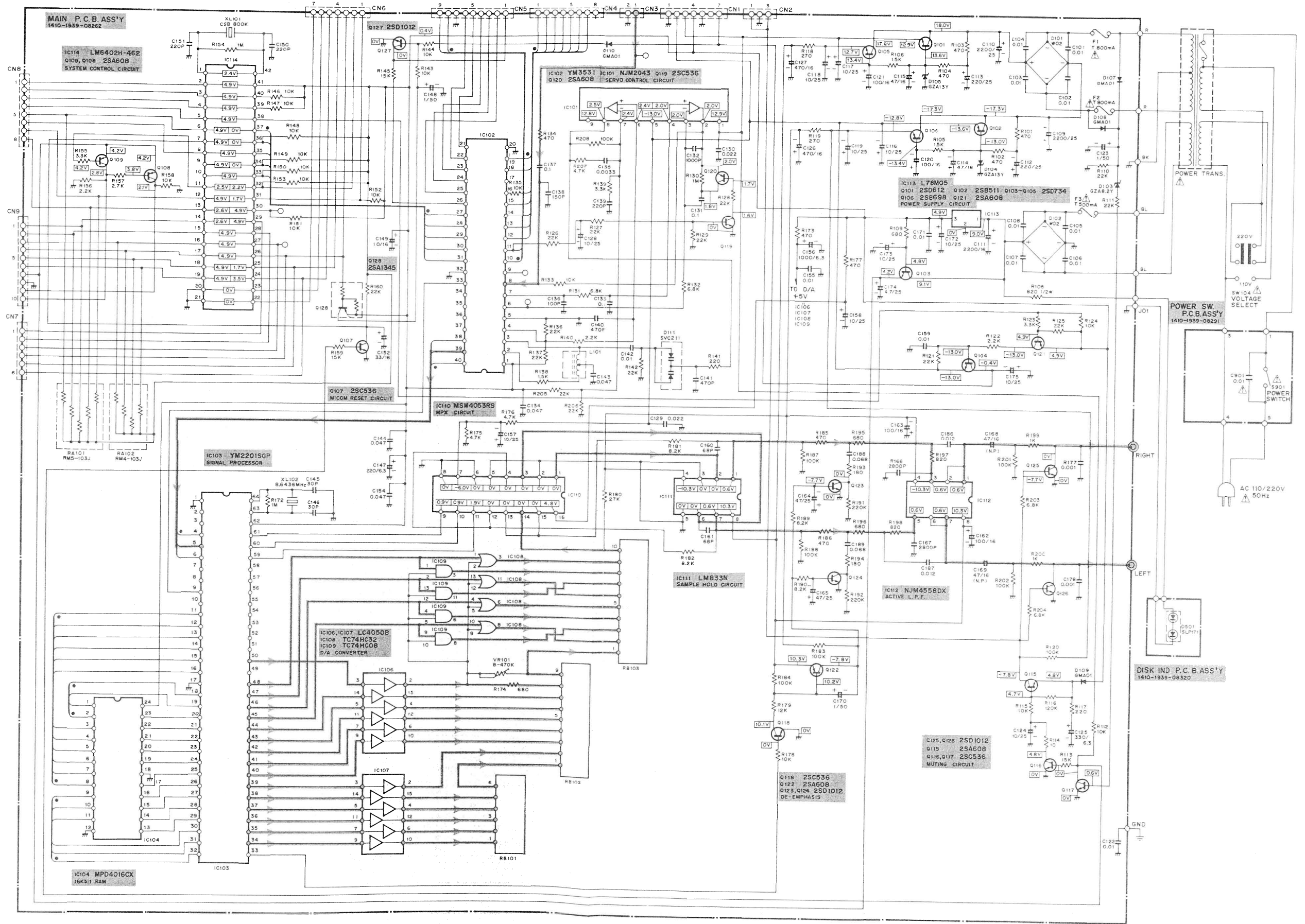

SCHEMATIC DIAGRAM (Continued)

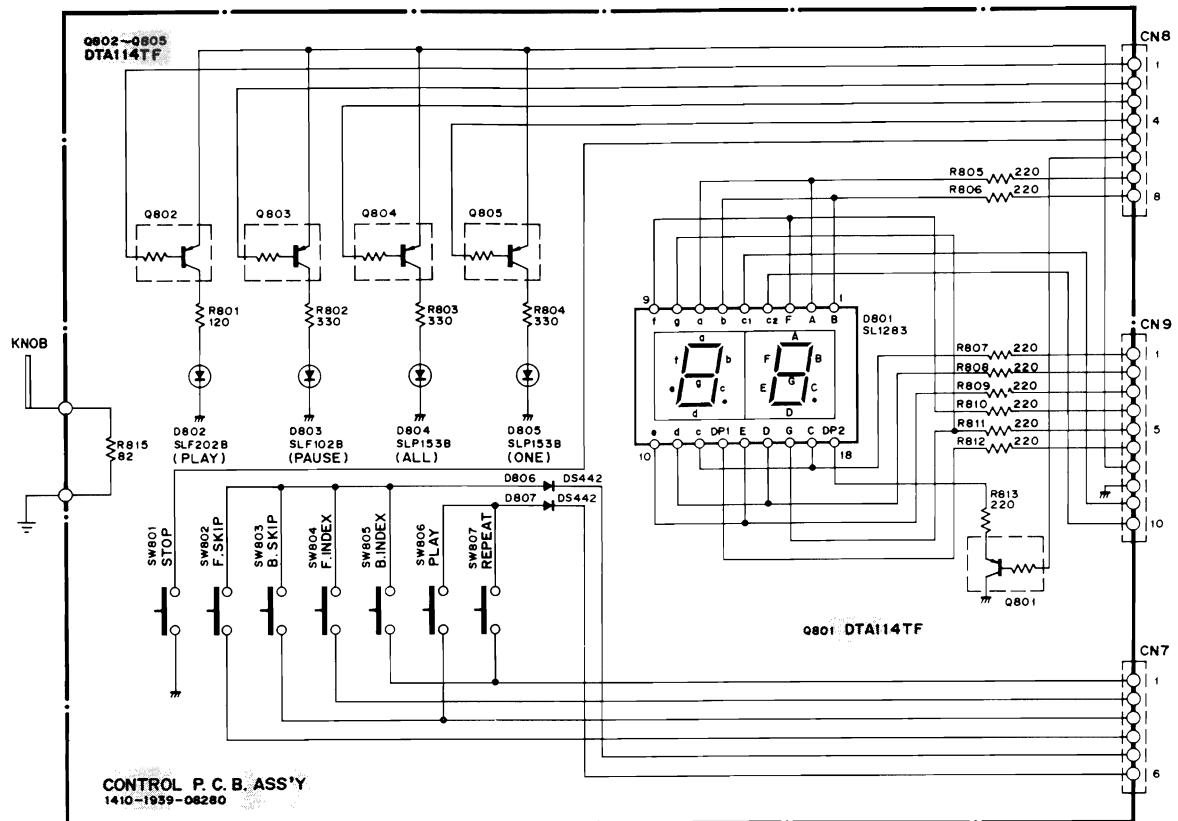

No.	Name	Position
SW101	OPEN/CLOSE Switch	OFF
SW102	PICKUP LIMIT Switch	IN
SW103	LOADING LIMIT Switch	CLOSE
SW104	VOLTAGE SELECT Switch	220V
SW801	STOP Switch	OFF
SW802	F. SKIP Switch	OFF
SW803	B. SKIP Switch	OFF
SW804	F. INDEX Switch	OFF
SW805	B. INDEX Switch	OFF
SW806	PLAY Switch	OFF
SW807	REPEAT Switch	OFF
SW901	POWER Switch	OFF

NOTES:

1. All resistors values are indicated in "ohm" ($K=10^3$, $M=10^6$).
2. All capacitors values are indicated in " μF " ($P=10^{-12}$).
3. All voltages indicated on the schematics are measured under the following conditions.
 - a. Use a V.T.V.M.

- b. All voltages $\pm 10\%$ with respect to chassis ground
- c. No signals at input terminals
- d. AC input at 220 volts 50 Hz
4. This is a basic schematic diagram.

Because Fisher products are subject to continuous improvement, Fisher Corporation reserves the right to make any changes or modifications without notice.

IC SIGNAL FLOW & EQUIVALENT CIRCUIT

YM 3531

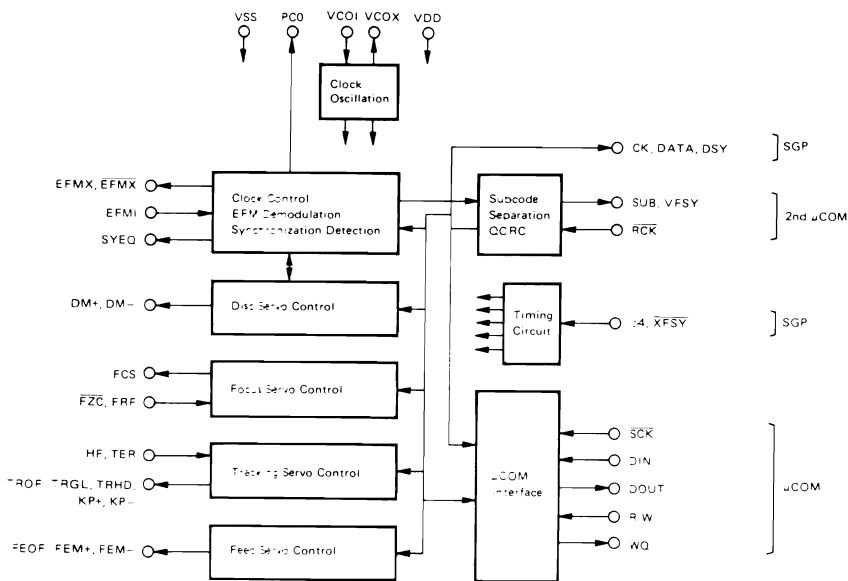

TOP VIEW

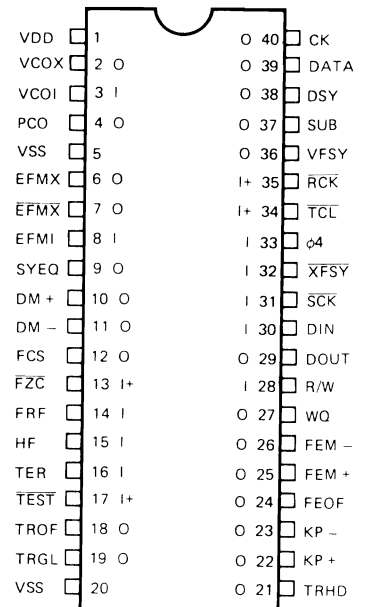

YM 2201

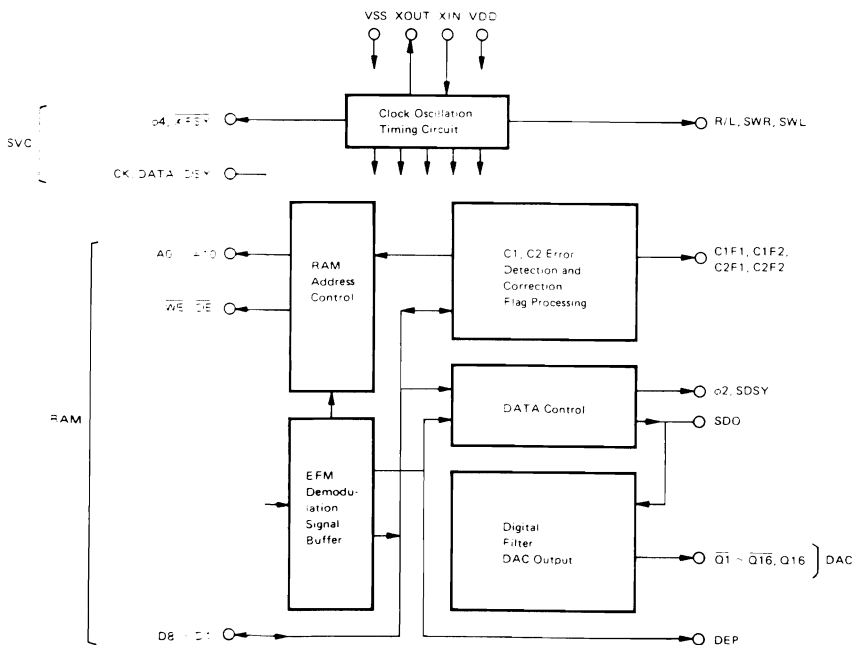

TOP VIEW

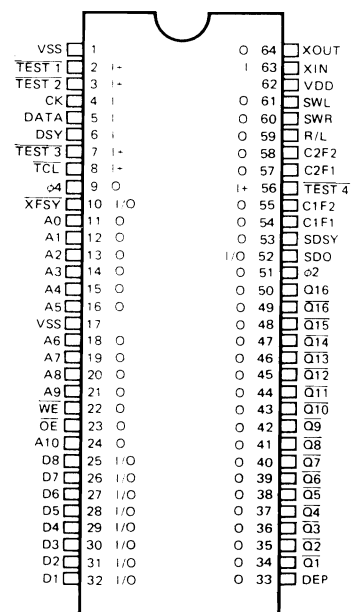

IC SIGNAL FLOW & EQUIVALENT CIRCUIT (Continued)

NJM 2043, NJM 4558 S, TA 75393 S

NJM 4558 DX, LM 833 N

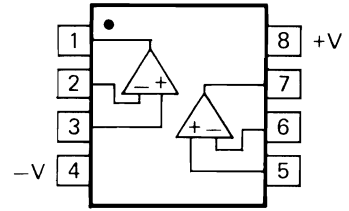
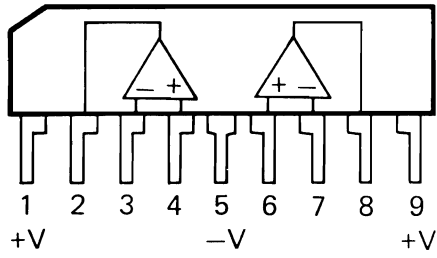

MSM 4053 RS

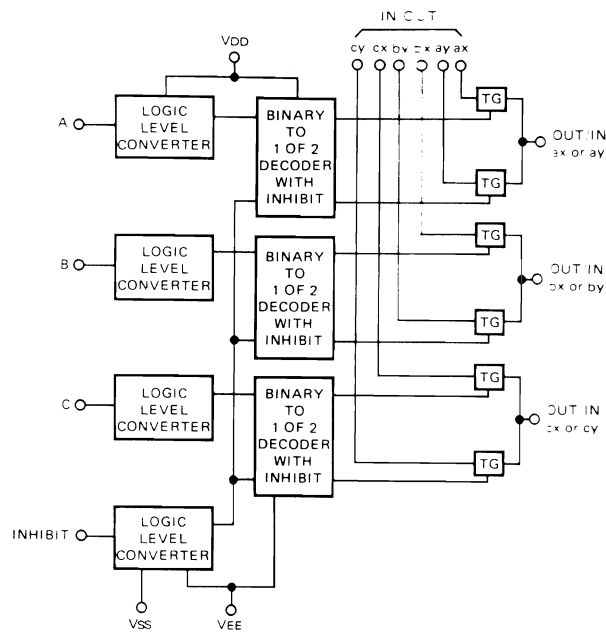

TC 40H004 P

STA 451 C

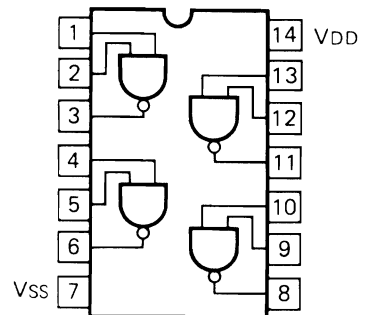
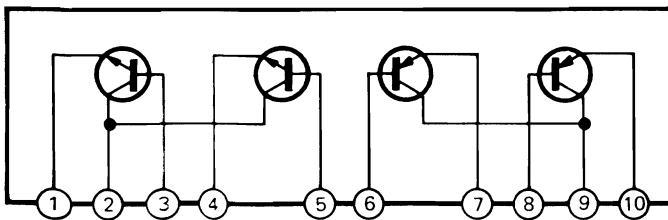

IC SIGNAL FLOW & EQUIVALENT CIRCUIT (Continued)

μ PD 4016

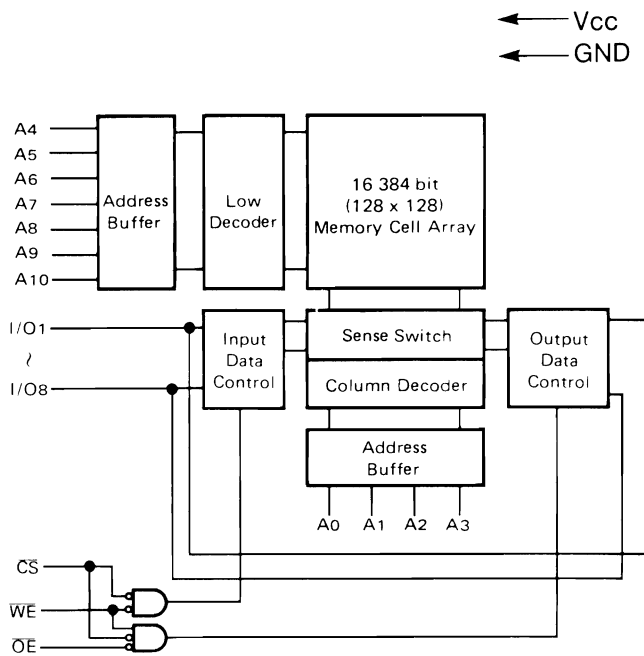

TOP VIEW

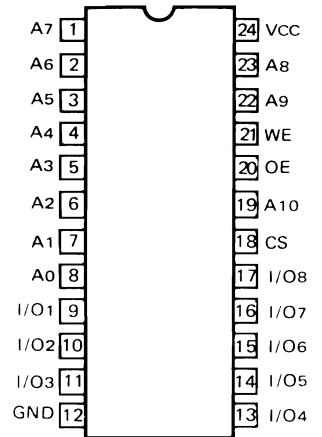

- A0 ~ A10 : Address Input
- I/O1 ~ I/O8 : Data I/O Chip Select
- CS : Chip Select Input
- WE : Write Enable Input
- OE : Output Enable Input
- Vcc : +5V Power Source
- GND : Ground

L78M05

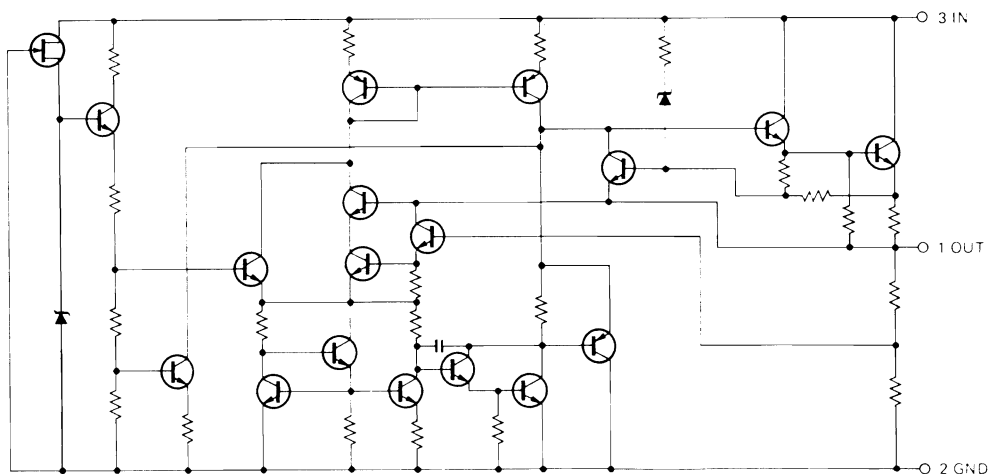

IC SIGNAL FLOW & EQUIVALENT CIRCUIT (Continued)

LM 6402

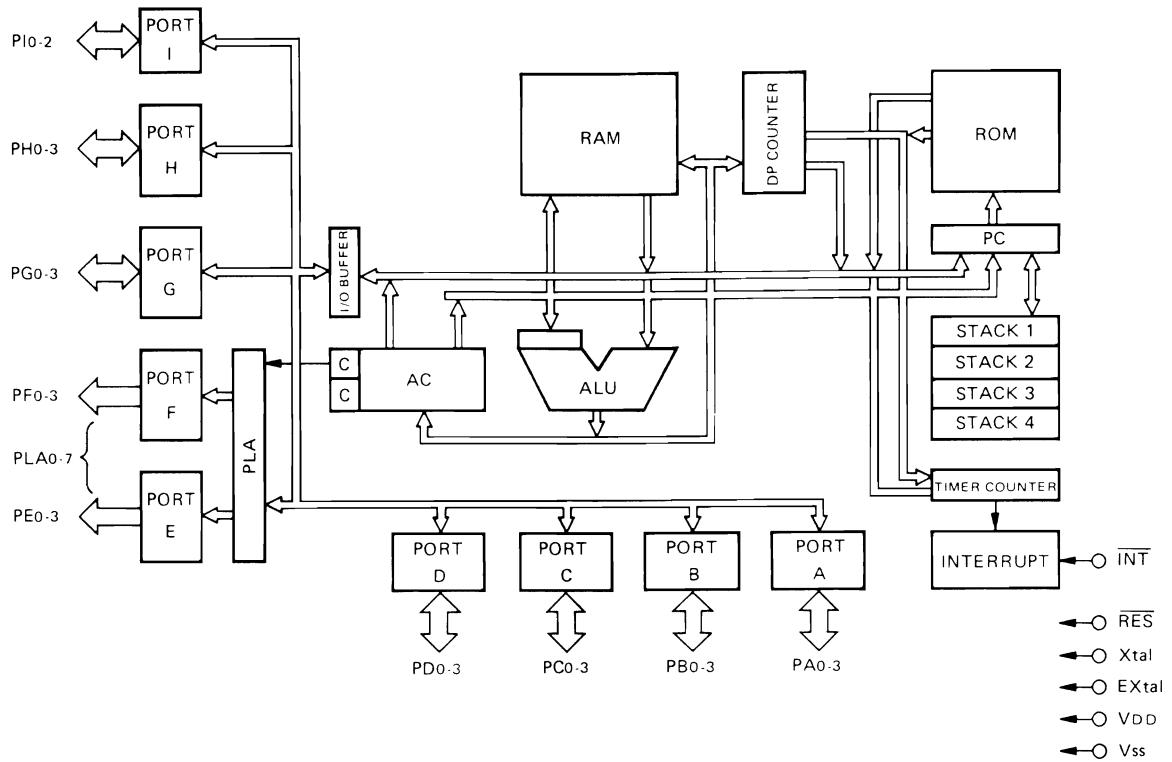

SEMICONDUCTOR LEAD IDENTIFICATION

INTEGRATED CIRCUITS

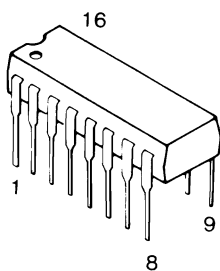

- LC 4050 B
- MSM 4053 RS

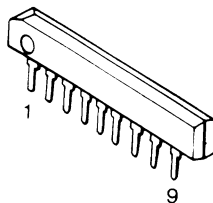

- NJM 2043 S
- NJM 4558 S
- TA 75393 S

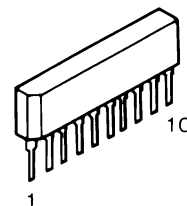

- STA 451 C

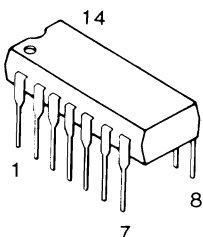

- TC 40H 004 P
- TC 74HC 08
- TC 74HC 32

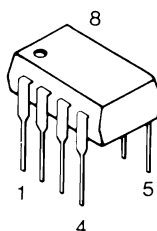

- LM 833 N
- NJM 4558 DX

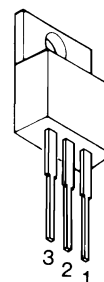

- L 78M05

TRANSISTORS

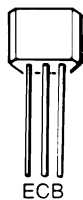

- 2SA 1345
- 2SD 1012

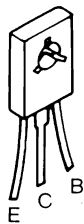

- 2SD 612

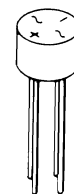

- W02



- 2SA 608
- 2SB 698
- 2SC 536
- 2SD 734

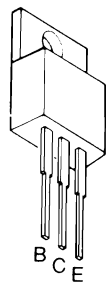

- 2SB 511

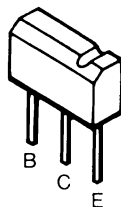

- DTA 114 TF



- SVC 211

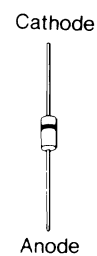

- DS 442
- GMA 01
- GZA 8.2 Y
- GZA 13 Y