

SERVICE MANUAL



AD-839 (EUROPE)

Compact Disc Player



SPECIFICATIONS

PRODUCT CODE No.

137 037 51 AD-839

NOTE:

The below mentioned specifications are mainly based on the IHF measurements standard.

They can therefore not directly be compared with specifications based on the DIN standard or other standards.

Audio		Pickup	
Channels	2 channels	System	Light pickup (3 -beam)
Frequency response	5-20,000Hz	Light source . . .	Semiconductor laser
S/N ratio	96 dB	Wave length . . .	790 nm
Channel separation	90dB (1 kHz)	General	
Distortion	0.05% (1 kHz)	Power supply . .	AC 230V, 50HZ
Wow and flutter . .	Undetectable	Dimensions . . .	(approx.) 420(W) × 86(H) × 270(D) mm
Outputs	1.37 V/1k ohms		
Signal format			
Sampling frequency	44.1 kHz		
Quantization	16 bits linear / channel		
Transmission rate	4.32 Mbit / sec.		

Specifications and design subject to change without notice.

REFERENCE NO. WM-580599

SCHEMATIC DIAGRAM

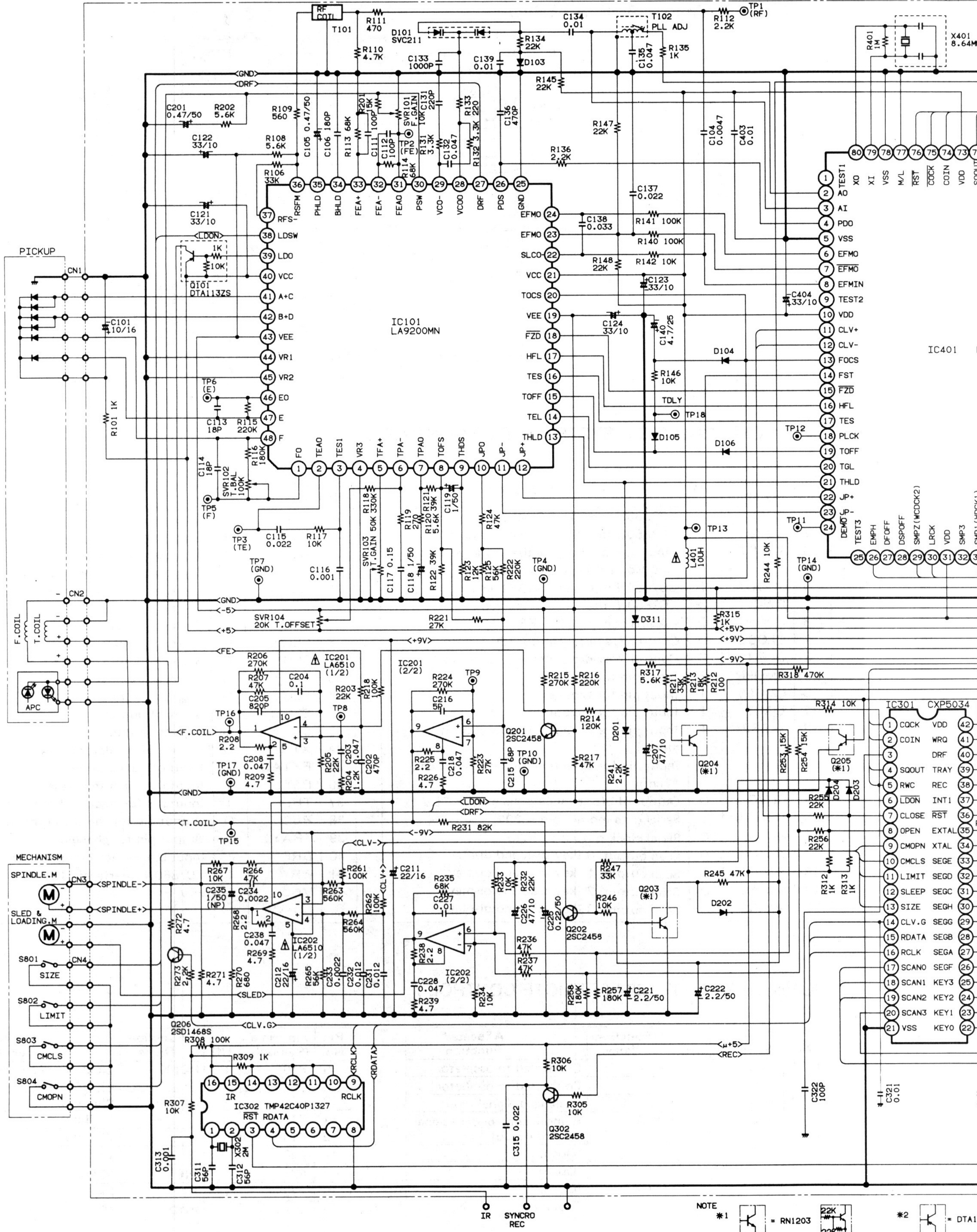

NOTE *1 = RN1203 *2 = DTA113ZS

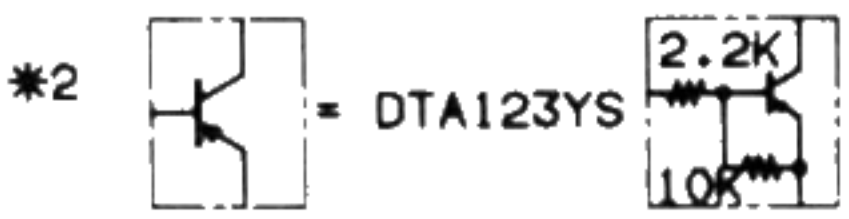
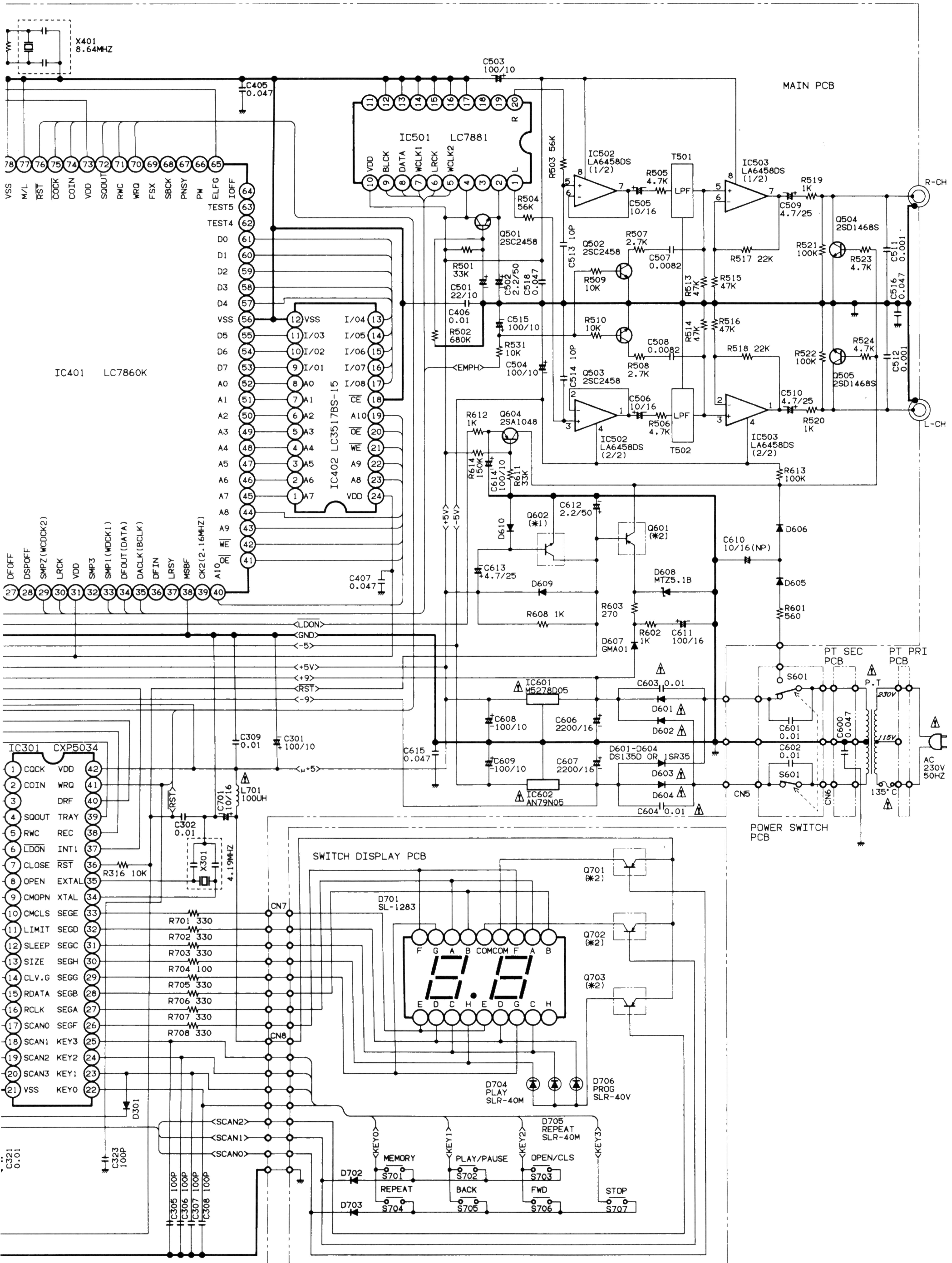

NON-DESIGNATED DIODE GMA01