

*Stereophonic*

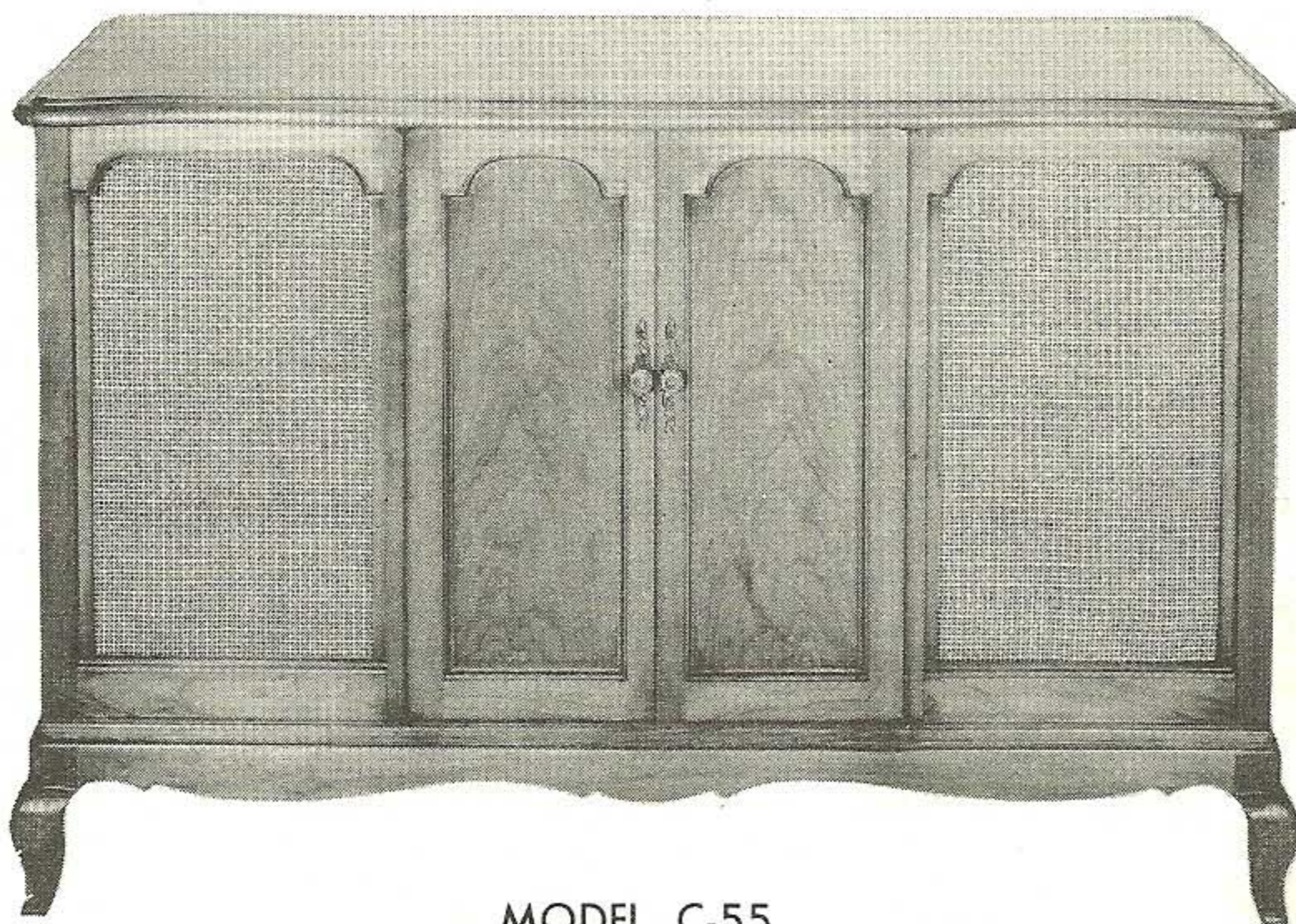

**THE FISHER  
CORONET  
SERVICE  
MANUAL**



MODEL C-55

CHASSIS SERIAL NUMBERS  
FROM 30001 TO 39999 INCLUSIVE

FISHER RADIO CORPORATION • NEW YORK



CHASSIS SERIAL NUMBERS  
FROM 30001 TO 39999 INCLUSIVE

**THE FISHER C-55**



# PARTS DESCRIPTION LIST • TUNERS AND PREAMPLIFIER

## CAPACITORS

10% tolerance for all fixed capacitors, unless otherwise noted or marked. GMV (guaranteed minimum value.)

Symbol	Description	Part No.
C1	Ceramic, 24uuf 5% N150, 1000V	C50070-8
C2	Ceramic, 8uuf ± .5uuf NPO, 500V	CC20CJ080D5
C3	not used	
C4	Ceramic, 100uuf N1500, 1000V	C50070-6
C5	Ceramic, Trimmer	C662-123
C6	FM Variable	C726-116
C7	AM Variable	C684-127
C8, 9	Ceramic, 100uuf, N1500, 1000V	C50070-6
C10	Ceramic, Feedthru, .001uf GMV	C592-187
C11	Ceramic, .02uf + 80 — 20%, 500V	C50089-4
C12	Ceramic, Feedthru, .001uf GMV	C592-187
C13	Ceramic, .02uf + 80 — 20%, 500V	C50089-4
C14	Ceramic, 18uuf, N470, 1000V	C50070-13
C15	Ceramic, Feedthru, .001uf GMV	C592-187
C16	Ceramic, .001uf, 1000V	C50072-3
C17	Ceramic, .68uuf, 500V	C50077-6N
C18	Ceramic, Feedthru, .001uf GMV	C592-187
C19	Ceramic, 5uuf ± .5uuf NPO, 1000V	CC20CJ050D5
C20	not used	
C21	Ceramic, .02uf + 80 — 20%, 500V	C50089-4
C22	Ceramic, Trimmer	C662-123
C23	Ceramic, 10uuf ± .5uuf NPO, 500V	CC20CJ100D5
C24	Ceramic, 100uuf N1500, 1000V	C50070-6
C25	Ceramic, 2.2uuf, 500V	C3039
C26	Ceramic, .02uf + 80 — 20%, 500V	C50089-4
C27	Ceramic, 68uuf N750, 500V	CC20UJ680K5
C28	Ceramic, 100uuf N1500, 1000V	C50070-6
C29	Ceramic, 5uuf ± .5uuf N150, 500V	CC20PJ050D5
C30	Ceramic, 47uuf N750, 1000V	C50070-6
C31	Ceramic, 5uuf ± .5uuf N220, 500V	CC20RH050D5
C32	Ceramic, Trimmer	C662-123
C33	Ceramic, 100uuf GMV, 1000V	C50070-5
C34	Ceramic, .02uf + 80 — 20%, 500V	C50089-4
C35	Ceramic, 24uuf 5% N150, 1000V	C50070-8
C36	Ceramic, Feedthru .001uf GMV	C592-187
C37	Ceramic, 100uuf 5%, N1500, 1000V	C50070-19
C38	Ceramic, 10uuf ± .5uuf NPO, 500V	CC20CJ100D5
C39	Ceramic, .001uf, 1000V	C50072-3
C40	Ceramic, .68uuf, 500V	C50077-6N
C41	Ceramic, .02uf + 80 — 20%, 500V	C50089-4
C42	Ceramic, Feedthru .001uf GMV	C592-187
C43	Ceramic, .02uf + 80 — 20%, 500V	C50089-4
C44	Ceramic, .005uf, 20%, 500V	C50089-1
C45	Ceramic, .0027uf, 20%, 1000V	C50071-5
C46	Ceramic, .005uf, 20%, 500V	C50089-1
C47	Ceramic, .02uf + 80 — 20%, 500V	C50089-4
C48	Ceramic, .005uf, 20%, 500V	C50089-1
C49	Ceramic, 900uuf, 5%, 500V	CC21GP901J5
C50	Ceramic, .02uf + 80 — 20%, 500V	C50089-4
C51	Ceramic, .005uf, 20, 500V	C50089-1
C52	Ceramic, .05uf + 80 — 20%, 100V	C50073-2
C53, 54	Ceramic, .005uf, 20%, 500V	C50089-1
C55	Ceramic, .0027uf, 20%, 1000V	C50071-5
C56	Ceramic, 220uuf, 1000V	C50072-20
C57	Ceramic, .02uf + 80 — 20%, 500V	C50089-4
C58	Ceramic, .0027uf, 20%, 1000V	C50071-5
C59	Ceramic, .005uf, 20%, 500V	C50089-1
C60	Mylar, .1uf, 400V	C50197-32
C61	Ceramic, 330uuf, 1000V	C50072-1
C62	Molded, .0033uf, 5%, 200V	C68P332J2
C63	Ceramic, .005uf, 20%, 500V	C50089-1
C64, 65	Ceramic, 330uuf, 1000V	C50072-1

C66	Electrolytic, 8uf, 50V	C629-138
C67, 68	Ceramic, 220uuf, 1000V	C50072-20
C69, 70	Ceramic, 100uuf, GMV N1500, 1000V	C50070-5
C71, 72	Ceramic, .01uf, 20%, 500V	C50089-3
C73, 74	Ceramic, .02uf, 20%, 500V	C50089-5
C75, 76	Ceramic, .05uf + 80 — 20%, 100V	C50073-2
C77, 78	Ceramic, 39uuf, N1500, 1000V	C50070-17
C79, 80	Ceramic, .02uf, 20%, 500V	C50089-5
C81	Ceramic, 220uuf, 1000V	C50072-20
C82	Ceramic, .0033uf, 1000V	C50072-11
C83	Ceramic, 220uuf, 1000V	C50072-20
C84	Ceramic, .0033uf, 1000V	C50072-11
C85	Ceramic, .001uf, 1000V	C50072-3
C86	Ceramic, .01uf 20%, 500V	C50089-3
C87	Ceramic, .001uf, 1000V	C50072-3
C88	Ceramic, .01uf, 20%, 500V	C50089-3
C89, 90	Ceramic, .05uf, + 80% — 20% 100V	C50073-2
C91	Ceramic, 39uuf, N1500, 1000V	C50070-17
C92	Ceramic, 68uuf, N750, 1000V	C50070-16
C93	Ceramic, .0015uf, 1000V	C50072-10
C94	Ceramic, .0027uf, 1000V	C50072-17
C95	Ceramic, .0015uf, 1000V	C50072-10
C96	Ceramic, .0027uf, 1000V	C50072-17
C97, 98	Ceramic, .02uf, 20%, 500V	C50089-5
C99, 100	Ceramic, 18uuf, N470, 1000V	C50070-13
C101, 102	Ceramic, .02uf, 20%, 500V	C50089-5
C103	Mylar, .1uf, 400V	C50197-32
C104	Ceramic, .02uf, 20%, 500V	C50089-5
C105	Ceramic, 82uuf, N1500, 1000V	C50070-7
C106	Mylar, .1uf, 400V	C50197-32
C107	Ceramic, .02uf, 20%, 500V	C50089-5
C108	Ceramic, 82uuf, N1500, 1000V	C50070-7
C109	Ceramic, .005uf, 20%, 500V	C50089-1
C110	Electrolytic, two section: A: 40uf, 250V B: 40uf, 250V	C50180-5
C111	Ceramic, .005uf, 20%, 500V	C50089-1
C112	Electrolytic, three section: A: 40uf, 300V B: 40uf, 250V C: 40uf, 250V	C670-125
C113	Electrolytic, two section: A: 500uf, 30V B: 500uf, 30V	C50180-6
C114	Ceramic, Feedthru, .001uf, GMV	C592-187
C115, 116, 117	Ceramic, .005uf, 20%, 500V	C50089-1
C118, 119	Molded, .01uf, 20%, 600V	C2747

## RESISTORS AND POTENTIOMETERS

In ohms, 10% tolerance, 1/2 Watt, unless otherwise noted. K = Kilohm, M = Megohm.

Symbol	Description	Part No.
R1	Composition, 270	RC20BF271K
R2	Composition, 1K	RC20BF102K
R3	Composition, 4.7	RC20BF47K
R4	Composition, 820K	RC20BF824K
R5	Composition, 100K	RC20BF104K
R6	Composition, 100	RC20BF101K
R7	Composition, 47K	RC20BF473K
R8, 9	Composition, 330K	RC20BF334K
R10	Composition, 4.7	RC20BF47K
R11	Composition, 22	RC20BF220K
R12	Composition, 2.2K	RC20BF222K
R13	Composition, 33K 1W	RC30BF333K
R14	Composition, 220	RC20BF221K
R15	Composition, 47K	RC20BF473K

**R16** Composition, 470K  
**R17** Composition, 1K  
**R18** Composition, 270  
**R19** Composition, 150  
**R20** Composition, 33K 1W  
**R21** Composition, 270  
**R22** Composition, 68K  
**R23** Composition, 2.2K 1W  
**R24** Potentiometer, 250 K AM Level set  
**R25, 26** Composition, 1K  
**R27** Composition, 180  
**R28** Composition, 27K  
**R29** Composition, 150  
**R30** Composition, 1K  
**R31** Composition, 47K  
**R32** Composition, 1M  
**R33** Composition, 39K  
**R34** Composition, 82K  
**R35** Composition, 1K  
**R36** Composition, 3.3M  
**R37** Composition, 2.2M  
**R38** Composition, 47K  
**R39** Composition, 470K  
**R40** Composition, 68K  
**R41** Composition, 82K  
**R42** Composition, 1K  
**R43** Composition, 270  
**R44** Composition, 56K  
**R45** Composition, 68K  
**R46** Potentiometer, 100 K MPX Balance  
**R47** Composition, 10M  
**R48** Composition, 68K  
**R49** Composition, 1.5K  
**R50** Composition, 1K  
**R51** Composition, 470K  
**R52, 53** Composition, 6.8K  
**R54** Composition, 180K  
**R55** Composition, 1.2M  
**R56, 57** Composition, 47K  
**R58** Composition, 10K  
**R59** Composition, 10  
**R60** Composition, 10K  
**R61** Composition, 10  
**R62, 63** Dep. Carbon, 2.7K, 5 %  
**R64, 65** Dep. Carbon, 330K, 5 %  
**R66, 67** Dep. Carbon, 4.7M, 5 %  
**R68, 69** Dep. Carbon, 220K, 5 %  
**R70** Potentiometer, 250K, Phono A level set  
**R71, 72** Composition, 470K  
**R73** Composition, 5.6M, 5 %  
**R74** Dep. Carbon, 2.2M, 5 %  
**R75** Composition, 5.6M, 5 %  
**R76** Dep. Carbon, 2.2M, 5 %  
**R77** Composition, 100K  
**R78** Composition, 560  
**R79** Composition, 100K  
**R80** Composition, 560  
**R81, 82** Composition, 220K  
**R83** Potentiometer, dual 1 M treble  
**R84** Composition, 220K  
**R85** Potentiometer, dual 1M bass  
**R86** Composition, 15K  
**R87** Composition, 220K  
**R88** Composition, 15K  
**R89, 90** Composition, 39K  
**R91** Composition, 10M  
**R92** Dep. Carbon, 220K, 5 %

**RC20BF474K**  
**RC20BF102K**  
**RC20BF271K**  
**RC20BF151K**  
**RC30BF333K**  
**RC20BF271K**  
**RC20BF683K**  
**RC30BF222K**  
**R50160-3**  
**RC20BF102K**  
**RC20BF181K**  
**RC20BF273K**  
**RC20BF151K**  
**RC20BF102K**  
**RC20BF473K**  
**RC20BF105K**  
**RC20BF393K**  
**RC20BF823K**  
**RC20BF102K**  
**RC20BF335K**  
**RC20BF225K**  
**RC20BF473K**  
**RC20BF474K**  
**RC20BF683K**  
**RC20BF823K**  
**RC20BF102K**  
**RC20BF271K**  
**RC20BF563K**  
**RC20BF683K**  
**R50160-20**  
**RC20BF106K**  
**RC20BF683K**  
**RC20BF152K**  
**RC20BF102K**  
**RC20BF474K**  
**RC20BF682K**  
**RC20BF184K**  
**RC20BF125K**  
**RC20BF473K**  
**RC20BF103K**  
**RC20BF100K**  
**RC20BF103K**  
**RC20BF100K**  
**R33DC272J**  
**R33DC334J**  
**R33DC475J**  
**R33DC224J**  
**R50160-3**  
**RC20BF474K**  
**RC20BF565J**  
**R33DC225J**  
**RC20BF565J**  
**R33DC225J**  
**RC20BF104K**  
**RC20BF561K**  
**RC20BF104K**  
**RC20BF561K**  
**RC20BF224K**  
**R50160-34**  
**RC20BF224K**  
**R50160-35**  
**RC20BF153K**  
**RC20BF224K**  
**RC20BF153K**  
**RC20BF393K**  
**RC20BF106K**  
**R33DC224J**

**R93** Composition, 10M  
**R94** Dep. Carbon, 220K, 5 %  
**R95, 96**  
**97, 98** Dep. Carbon, 2.2M, 5 %  
**R99, 100** Composition, 220K  
**R101** Composition, 100K  
**R102** Composition, 560  
**R103** Composition, 100K  
**R104** Composition, 560  
**R105** Potentiometer, dual 250 K balance  
**R106, 107** Dep. Carbon, 1.5M, 5 %  
**R108** Composition, 22M  
**R109** Dep. Carbon, 330K, 5 %  
**R110** Potentiometer, dual 500 K volume  
**R111** Composition, 22M  
**R112** Dep. Carbon, 330K, 5 %  
**R113, 114** Composition, 100K  
**R115, 116** Composition, 22K  
**R117** Dep. Carbon, 220K, 5 %  
**R118** Dep. Carbon, 470K, 5 %  
**R119** Composition, 10K  
**R120** Composition, 1K  
**R121** Wirewound, 270, 5W  
**R122** Wirewound, 330, 5W  
**R123** Wirewound, 30, 5W  
**R124, 125** Composition, 220  
**R126** Dep. Carbon, 220K, 5 %  
**R127** Potentiometer, 250 K Phono B level set  
**R128** Dep. Carbon, 470K, 5 %  
**RC20BF106K**  
**R33DC224J**  
**R33DC225J**  
**RC20BF224K**  
**RC20BF104K**  
**RC20BF561K**  
**RC20BF104K**  
**RC20BF561K**  
**R50160-33**  
**R33DC155J**  
**RC20BF226K**  
**R33DC334J**  
**R50160-32**  
**RC20BF226K**  
**R33DC334J**  
**RC20BF104K**  
**RC20BF223K**  
**R33DC224J**  
**R33DC474J**  
**RC20BF103K**  
**RC20BF102K**  
**R684-141**  
**R746-146**  
**R689-103**  
**RC20BF221K**  
**R33DC224J**  
**R50160-3**  
**R33DC474J**

#### COILS, CHOKES, AND TRANSFORMERS

Symbol	Description	Part No.
L1	Coil, FM Antenna	L726-124
L2	Coil, AM Antenna	L721-139
L3	AM Ferrite loop	L721-136
L4	Choke, 1 Micro Henry	L50066-2
L5, 6	Choke, 56 Micro Henries	L50066-19
L7	Choke, RF	L629-180
L8	Coil, FM RF.	L726-126
L9	Coil, FM Osc.	L726-125
L10	Choke, 1 Micro Henry	L50066-2
L11	Choke, .56 Micro Henries	L50066-19
L12	Choke, 1 Micro Henry	L50066-2
L13	Coil, AM Osc.	L50210-21
L14	Choke, 1.2 Micro Henries	L50066-3
L15	Coil, 10KC Filter	L644-120
L16	Choke, 3.3 Micro Henries	L50066-8
L17, 18	Choke Filament Ferrite Bead	L592-189
L19	Choke, 1.2 Micro Henries	L50066-3
T1	Transformer, Power	T755-115
Z1	Transformer, FM IF	ZZ662-117
Z2	Transformer, FM IF	ZZ2987
Z3	Coil, FM Limiter	L670-145
Z4	Transformer, FM Radio Detector	ZZ592-170
Z5	Transformer, AM RF	L556-125
Z6	Transformer, AM IF	ZZ50210-1
Z7	Transformer, AM IF	ZZ2984

#### MISCELLANEOUS

Symbol	Description	Part No.
F1	Fuse, 2 Amp.	F755-145
11, 12	Lamp, Dial Panel	150082-3
S1	Switch, Selector	S755-116
S2, 3, 4, 5, 6	Switch, Slide	S50200-2
S7	Switch, Loudness	Part of R110
S8	Switch, Power	Part of R110
SR1	Selenium Rectifier	SR755-140

# ALIGNMENT INSTRUCTIONS

## Read These Instructions With Extreme Care Before Attempting Alignment.

**CHASSIS:** Turn the station selectors completely counterclockwise, without forcing. Dial pointers should be at zero index mark on logging scale. If not, reset the dial pointers. Disconnect the external antennas and the antenna link. Set Ferrite Loop to normal position, parallel to rear panel. When using an oscilloscope for alignment, set the output level controls for no overload, as shown by the proper waveform shape.

**SIGNAL GENERATORS:** The signal generator equipment must be able to supply the following: FM RF modulated 30% ( $\pm 22.5$  KC deviation) at 400 cps; AM RF modulated 30% at 400 cps;

AM IF with 30KC sweep for AM bandwidth adjustment; audio oscillator accurately calibrated for 1 and 10KC audio output for testing the 10KC AM whistle filter.

**INDICATOR:** DC VTVM, AC VTVM, and scope for alignment. AC VTVM for 10 KC AM whistle filter adjustment.

**ALIGNMENT:** Allow the chassis and test instruments to warm up for at least fifteen minutes. Adjust the line voltage for 117 volts AC, 50-60 cycles. Use fully insulated tools: a small screwdriver for all trimming capacitors; a K-Tran tool for Z1, Z2, Z3, Z5, Z6 and Z7; a hex tool for Z4, L1, L8 and L9. For AM alignment, short test point 4 to ground.

## AM ALIGNMENT

STEPS	CHASSIS			SIGNAL GENERATOR			INDICATOR		ALIGNMENT	
	AM BANDWIDTH	SELECTOR	STATION SELECTOR	COUPLING	FREQ.	MOD.	TYPE	CONNECTION	ADJUST	INDICATION
1	SHARP	AM	Point of no signal and no interference	Audio Gen. connected to Pin 7 of V9	1 KC	None	AC VTVM to Ch. A RCRDR Output			0 db at 1 KC
					10 KC					- 25 db at 10 KC
2	SHARP	AM	Point of no signal and no interference	AM Gen. connected thru .01-uF cap. in series with hot lead to V8, Pin 2	455 KC	30% AM at 400 cps	AC VTVM to Ch. A RCRDR Output	Z6, Z7 top and bottom	Maximum voltage	
3	BROAD	AM	Point of no signal and no interference	AM Gen. connected thru .01-uF cap. in series with hot lead to V8, Pin 2	455 KC	30 KC sweep	Scope to Ch. A RCRDR Output	Z6 Bottom	Adjust slightly for symmetrical curve	
4	SHARP	AM	600 KC	AM Gen. connected thru 220-uF cap. in series with hot lead to antenna terminal 3 Disconnect link between 1 & 2	600 KC	30% AM at 400 cps	AC VTVM to Ch. A RCRDR Output	L13, Z5	Maximum voltage	
5	SHARP	AM	1400 KC	AM Gen. connected thru 220-uF cap. in series with hot lead to antenna terminal 3 Disconnect link between 1 & 2	1400 KC	30% AM at 400 cps	AC VTVM to Ch. A RCRDR Output	C7E, C7C, C7A	Maximum voltage	
6	Repeat steps 4 and 5 for proper dial calibration and maximum output.									
7		FM	Point of no signal and no interference	FM Gen. connected to ungrounded tube shield of V2	10.7 MC	None	DC VTVM to test point 1	Z1, Z2, Z3 and Z4, top & bottom	Maximum negative voltage	
8		FM	Point of no signal and no interference	FM Gen. connected to ungrounded tube shield of V2	10.7 MC	None	Connect VT VM to test point 2	Z4 top	Zero reading on zero center scale	
9		FM	90 MC	FM Gen. connected thru two 120-ohm carbon resistors in series with lead to antenna terminals 4 and 5	90 MC	30% FM (22.5 KC Dev.) at 400 cps	DC VTVM to the junction of R32 and R36 and scope to Ch. A. RCRDR Output	L1, L8 and L9	Check for sine waveform and adjust for maximum negative voltage	
10		FM	106 MC	FM Gen. connected thru two 120-ohm carbon resistors in series with lead to antenna terminals 4 and 5	106 MC	30% FM (22.5 KC Dev.) at 400 cps	DC VTVM to the junction of R32 and R36 and scope to Ch. A. RCRDR Output	C5, C22 and C32	Check for sine waveform and adjust for maximum negative voltage	
11	Repeat steps 9 and 10 at least once for proper dial calibration and maximum output.									

**NOTE:** For calibrating both the AM and FM, use as low an output voltage as possible from your signal generator.

## FM ALIGNMENT

# SCHEMATIC DIAGRAM • FM-AM TUNING SECTIONS

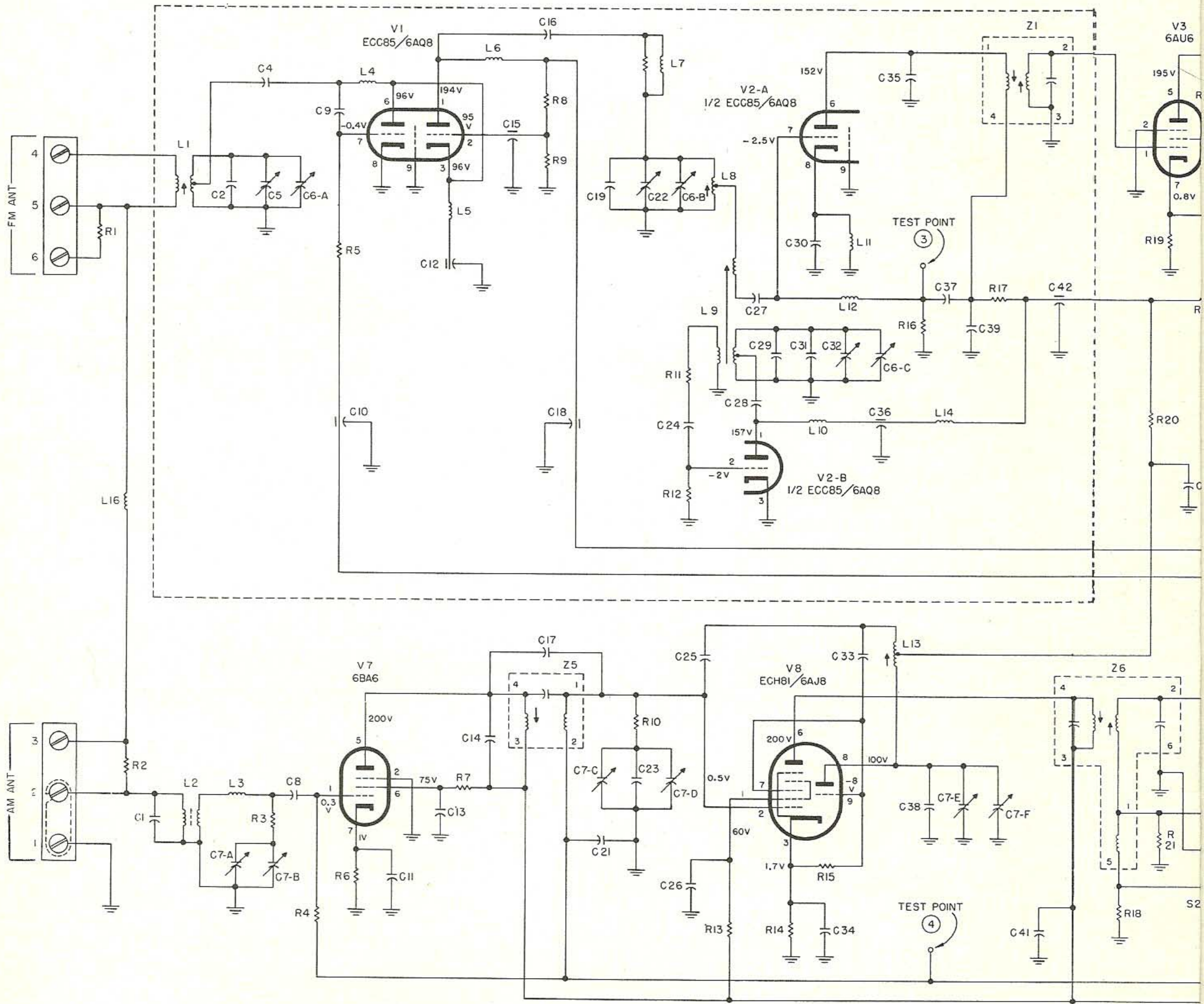

S1  
SELECTOR SWITCH  
POSITIONS

SHOWN IN → MONO PHONO  
PHONO STEREO  
AM  
FM  
FM-AM  
FM-MPX  
FM-FM  
AUX STEREO  
AUX MONO

R2  
←  
AM  
LEVEL SET

RESISTORS	R1	R2	R3	R4	R5 R6	R7	R8 R9	R10	R11 R12	R13	R14	R15	R16	R17	R18	R19 R20 R21	R20 R21			
CAPACITORS		C1	C2 C7-A	C4 C5	C6-A C7-B C8	C9 C10	C11 C12 C13	C14 C15	C16 C17 C18	C19 C21	C22 C23	C24 C6-B C7-D	C25 C26 C27 C28 C29	C30 C31	C32 C33 C34	C35 C36 C6-C	C37 C38	C39 C7-E	C41 C42	C43



# SCHEMATIC DIAGRAM • PREAMPLIFIER

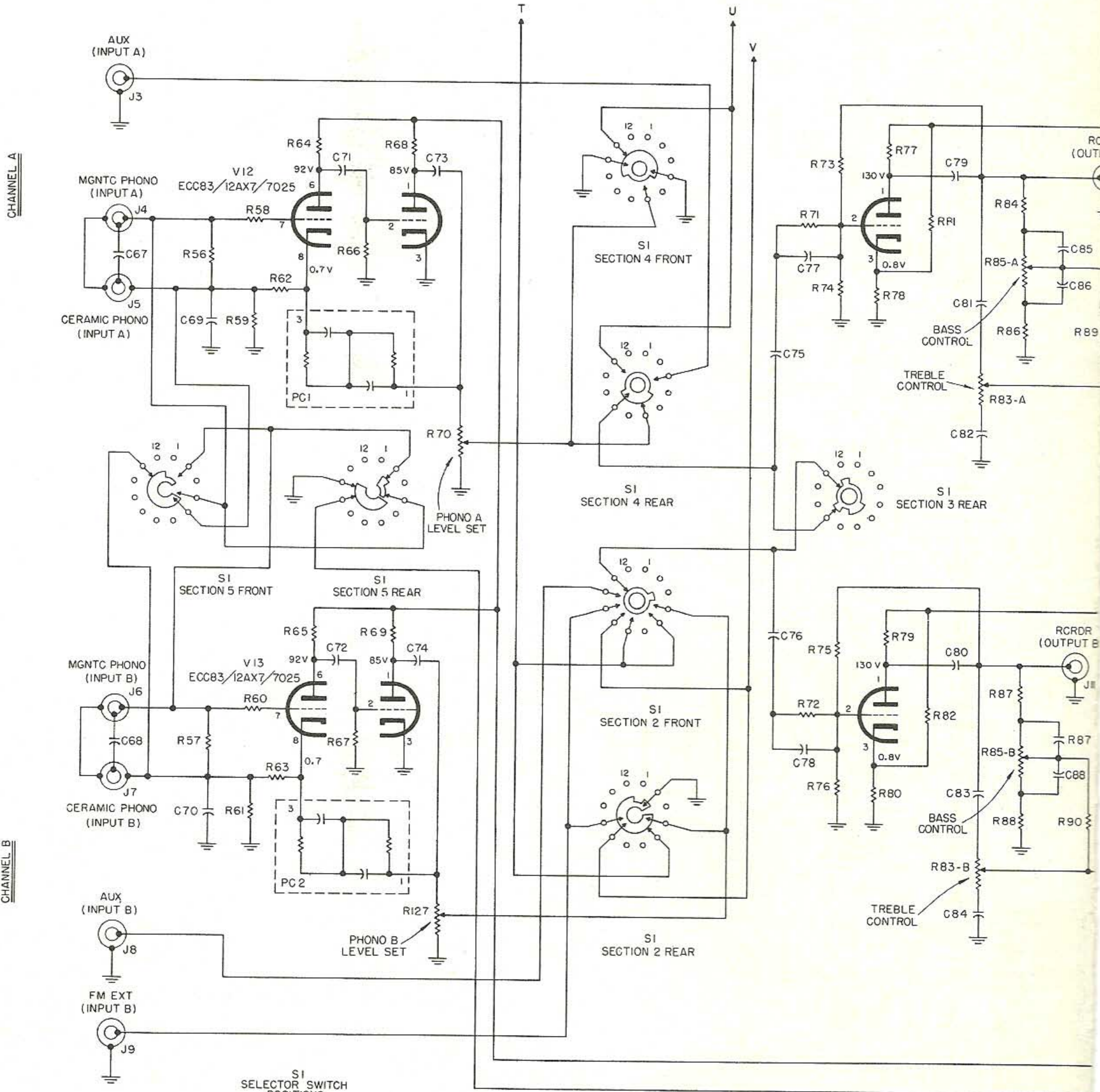

S1  
SELECTOR SWITCH  
POSITIONS

SHOWN IN → MONO PHONO  
PHONO STEREO  
AM  
FM  
FM-AM  
FM-MPX  
FM-FM  
AUX STEREO  
AUX MONO

RESISTORS	R56 R57	R58 TO R61	R62 R63	R64 R65	R66 R67	R68 R69	R70 R127	R71 R72	R73 TO R76	R77 TO R80	R81 R82	R83-A R83-B	R84 TO R88	R85 R89
CAPACITORS	C67 C68	C69 C70		C71 C72	C73 C74			C75 C76	C77 C78		C79 C80	C81 TO C84		C85 TO C88

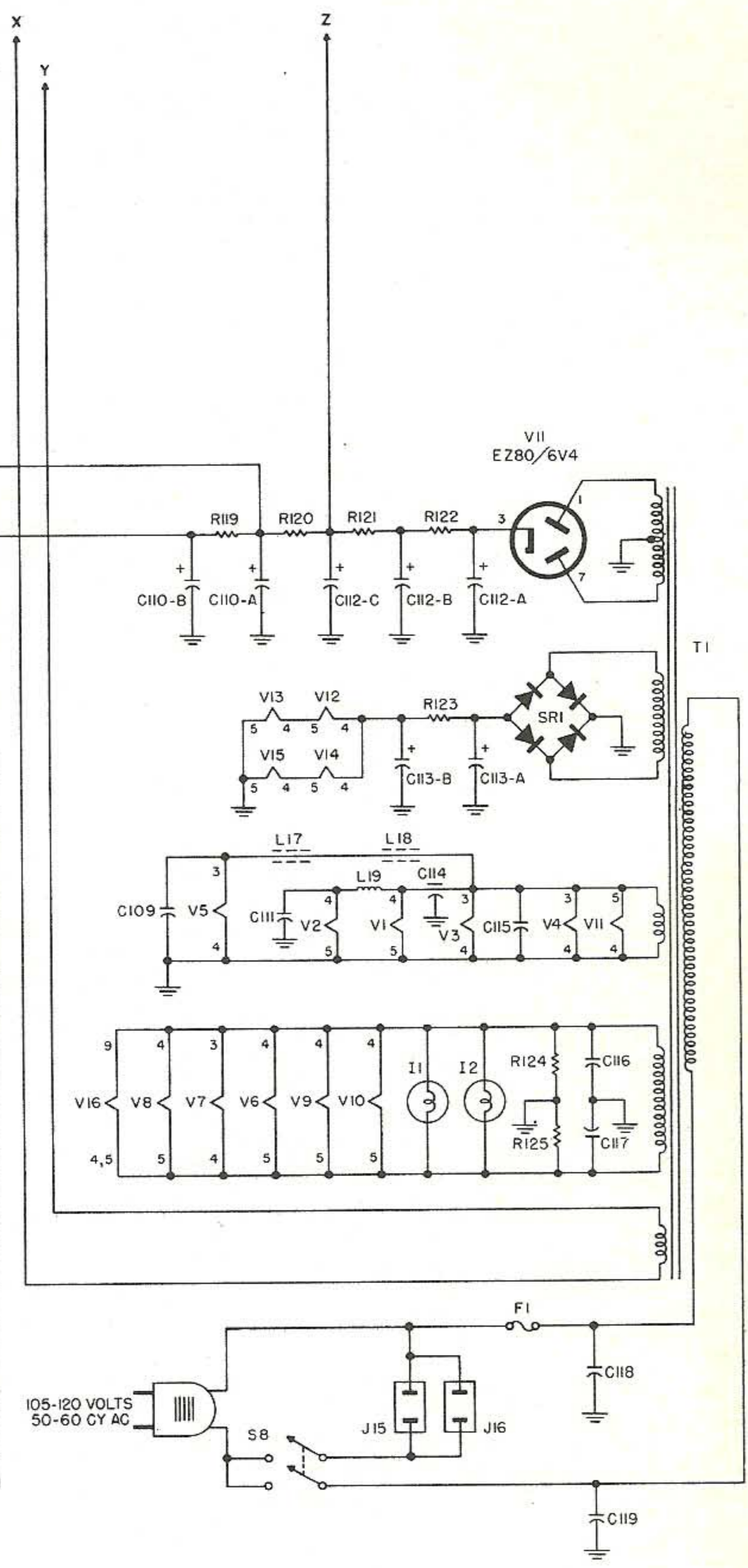
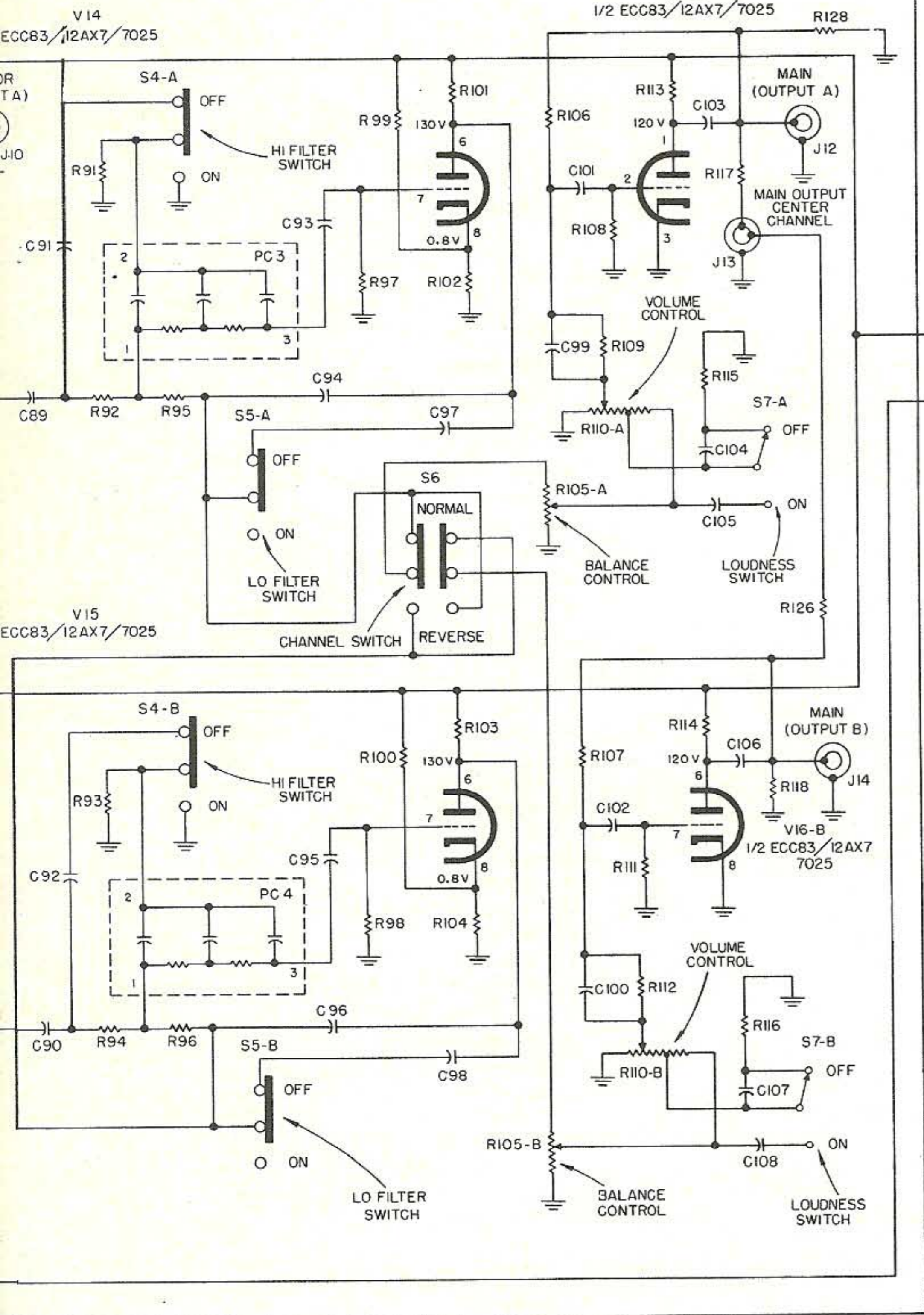

P755 SCHEMATIC AW # 1650  
SHEET 2 OF 2

R91 TO R94	R95 R96	R97 R98	R99 R100	R101 TO R104	R105-A R105-B	R106 TO R112	R113 R114 R115	R116 R117 R118	R126 R128	R119	R120	R121	R122 R123	R124 R125
C89 C90	C91 C92	C93 TO C96	C97 C98	C99 C100	C101 C102	C103 TO C108	C109	C110-B C110-A C111	C112-C C112-B C113-B C112-A C113-A C114	C115	C116 TO C119			



# SCHEMATIC DIAGRAM • AMPLIFIER SA-16

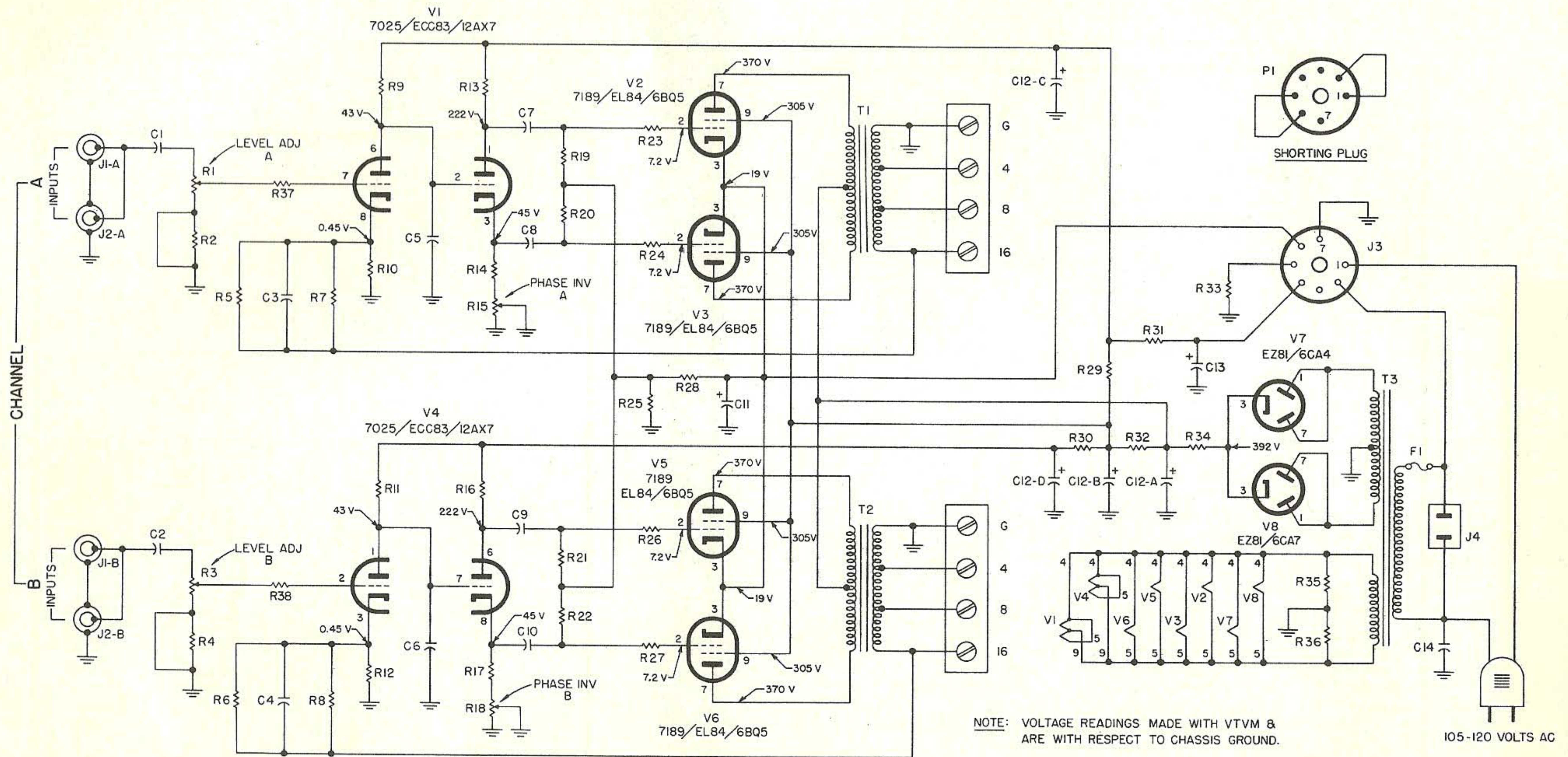

NOTE: VOLTAGE READINGS MADE WITH VTVM & ARE WITH RESPECT TO CHASSIS GROUND.

P754 SCHEMATIC AW#1637

## PHASE INVERTER BALANCE ADJUSTMENT

The phase inverter balance adjustments for Channel A and Channel B are located on the top surface of the SA-16 chassis. These adjustments should not be attempted unless you have a harmonic distortion analyzer and audio generator; or intermodulation analyzer. Make adjustments as follows:

1. Connect the audio generator to an input of the appropriate channel on the SA-16.
2. Load the output of the amplifier and connect the analyzer across the load.

3. If you are using a harmonic distortion analyzer, set the audio generator to 1000 cps. If you are using an intermodulation analyzer, connect its output to the input of the SA-16. Adjust the input signal to the SA-16 so that its output is just below the clipping point (about 1 db below.)

4. Keeping this output constant, adjust the phase inverter balance control (R15 or R18) for minimum distortion on the analyzer.

# TUBE LAYOUT

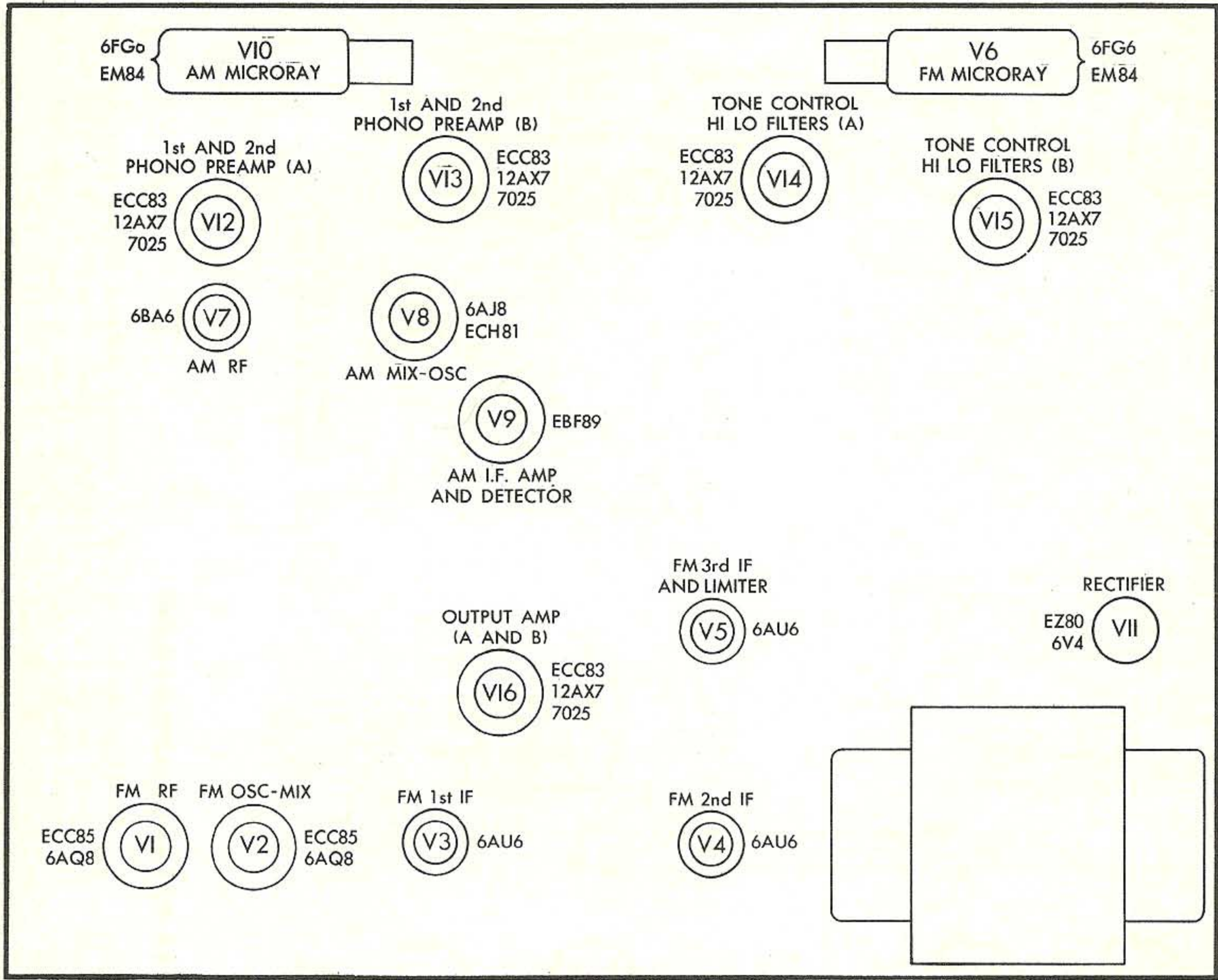

AW 1655

## TUNERS AND PREAMPLIFIER

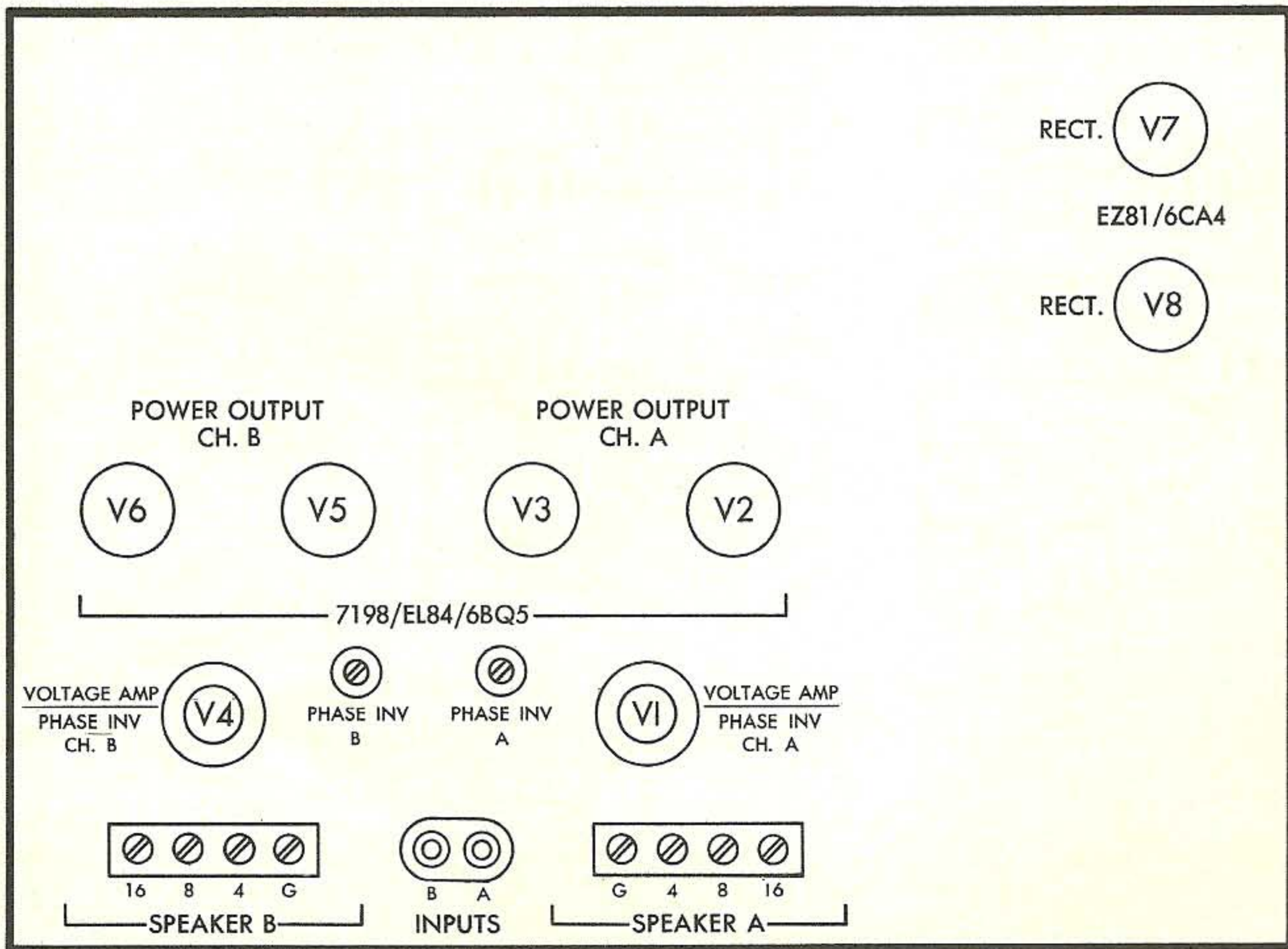

AW 1666

## AMPLIFIER SA-16

LS1

LS2

LS3

NEW YORK

**CAPACITORS**

10% tolerance for all fixed capacitors, unless otherwise noted or marked GMV (guaranteed minimum value.)

Symbol	Description	Part No.
C1, 2	Ceramic, .02uf 20%, 500V	C50089-5
C3, 4	Ceramic, 47uuf N750, 1000V	C50070-4
C5, 6	Ceramic, 220uuf, 1000V	C50072-20
C7, 8, 9, 10	Ceramic, .02uf 20%, 500V	C50089-5
C11	Electrolytic, 100uf, 100V	C663-143
C12	Electrolytic, four sections: A: 40uf, 450V B: 40uf, 400V C: 40uf, 350V D: 40uf, 350V	C50180-11
C13	Electrolytic, 10uf, 350V	C644-146
C14	Molded, .01uf 20%, 600V	C2747

**RESISTORS AND POTENTIOMETERS**

In ohms, 10% tolerance, 1/2 watt, unless otherwise noted. K = kilohm, M = megohm.

Symbol	Description	Part No.
R1	Potentiometer, 500K	R50103-6
R2	Composition, 1M	RC20BF105K
R3	Potentiometer, 500K	R50103-6
R4	Composition, 1M	RC20BF105K
R5, 6	Composition, 91K, 5%	RC20BF913J
R7, 8	Composition, 39K	RC20BF393K
R9	Composition, 680K	RC20BF684K
R10	Composition, 1.5K	RC20BF152K
R11	Composition, 680K	RC20BF684K
R12	Composition, 1.5K	RC20BF152K
R13	Composition, 82K	RC20BF823K
R14	Composition, 56K	RC20BF563K
R15	Potentiometer, 50K	R50103-3
R16	Composition, 82K	RC20BF823K
R17	Composition, 56K	RC20BF563K
R18	Potentiometer, 50K	R50103-3
R19, 20 21, 22	Composition, 820K	RC20BF824K
R23	Composition, 2.2K	RC20BF222K
R24	Composition, 33K	RC20BF333K
R25	Composition, 6.8K	RC20BF682K
R26	Composition, 2.2K	RC20BF222K
R27	Composition, 33K	RC20BF333K
R28	Composition, 10K	RC20BF103K
R29, 30	Composition, 22K	RC20BF223K
R31	Composition, 3.9K	RC20BF392K
R32	Wirewound, 3.5K, 7W	R754-122
R33	Wirewound, 125, 7W	R556-124
R34	Wirewound, 100, 10W	R754-121
R35	Composition, 220	RC20BF221K

**TRANSFORMERS**

Symbol	Description	Part No.
T1, 2	Transformer, Output	T725-116-1
T3	Transformer, Power	T754-115

**MISCELLANEOUS**

Symbol	Description	Part No.
F1	Fuse, 2 Ampere, Slo-Blo	F643-154

# SCHEMATIC DIAGRAM • SPEAKER SYSTEMS

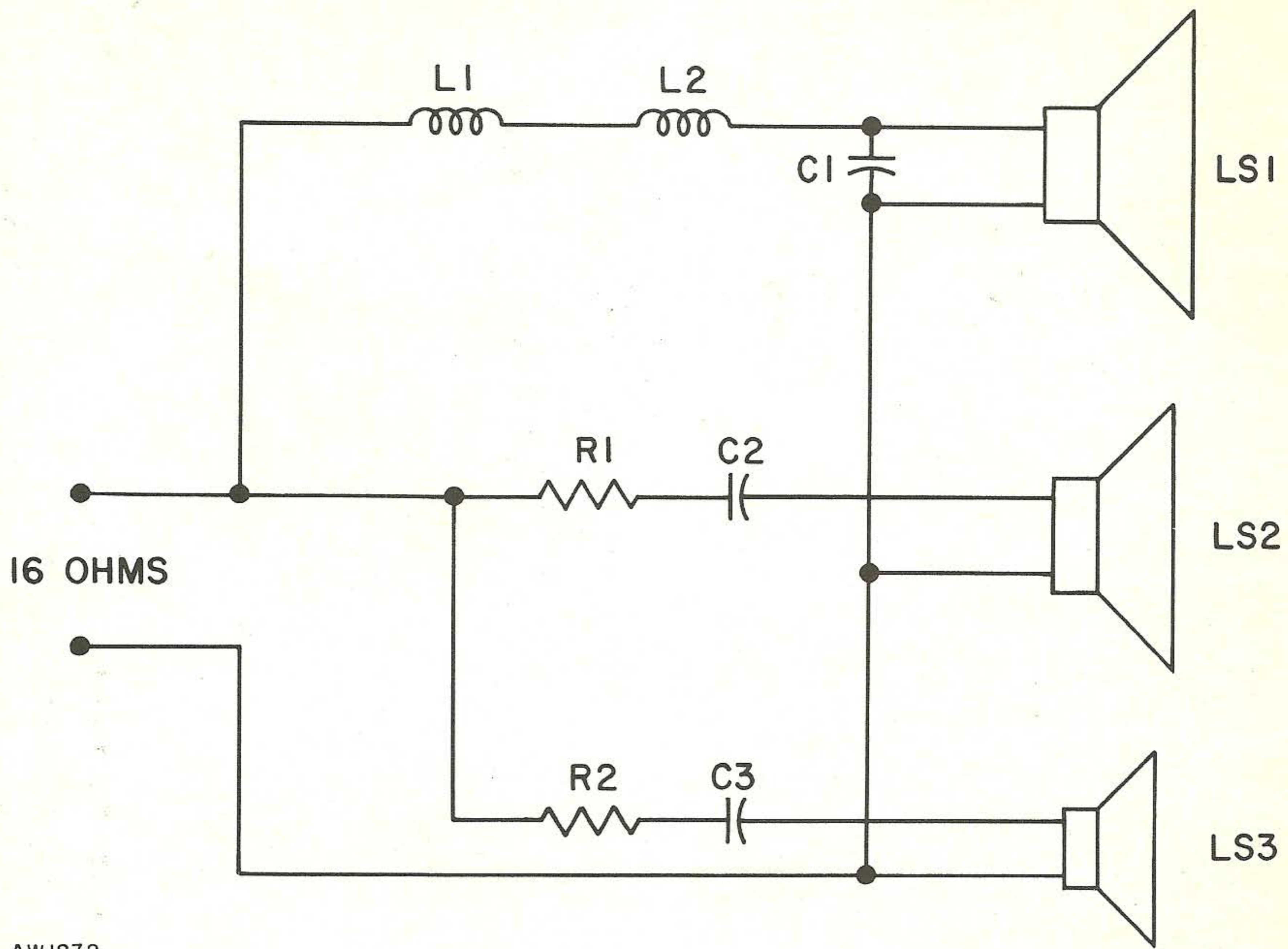

AW1832

## PARTS DESCRIPTION LIST • SPEAKER SYSTEMS

Symbol	Description	Part No.
C1	Electrolytic, non-polarized, 4uf, 20%, 50V	C831-107
C2	Paper, 2uf, 50V	C547-120
C3	Mylar, 0.47uf, 250V	C50197-56
L1, 2	Coil, 3 millihenries	L547-120
LS1	Speaker, 12-inch, woofer, 16 ohms	LS831-105
LS2	Speaker, 8-inch, mid-range, 16 ohms	LS831-106
LS3	Speaker, tweeter, 16 ohms	LS830-107
R1	Resistor, wirewound, 40 ohms, 10%, 5W	R689-104
R2	Resistor, wirewound, 10 ohms, 10%, 5W	R779-103



FISHER RADIO CORPORATION • NEW YORK

N831-104

Printed in U.S.A.

79W10C-120