

Nominal Specifications for Information Only.

AMPLIFIER		CA2310
POWER AMPLIFIER SECTION		
Continuous RMS sine wave power per channel within stated bandwidth at no more than stated distortion and with an 8 ohm load		70watts
Power Band Width		20Hz-20kHz
Total Harmonic Distortion		0.05%
IM Distortion		0.05%
Speaker Damping		40
PREAMPLIFIER SECTION		
Frequency Response	Phono (30Hz-15kHz) Aux (20Hz-20kHz)	±1.0dB ±1.0dB
Input Sensitivity and Impedance	Phono 1	2mV/50k ohm
	Phono 2	2mV/50k ohm
	Tape Monitor 1	150mV/100k ohm
	Tape Monitor 2	150mV/100k ohm
	Tuner Auxiliary	150mV/100k ohm 150mV/100k ohm
Phono Max. Input Capability		220mV
Tone Control	Bass (100Hz) Treble (10kHz) Turnover (Bass) Turnover (Treble)	±10dB ±10dB 200Hz/400Hz 3kHz/6kHz
Filter	Low at 16Hz (12dB/Oct.)	10dB
Loudness Contour (100Hz/10kHz)		+8dB/+4dB
Hum and Noise (IHF Short Circuit, A Net Work)	Phono 1, 2 Tape Monitor Tuner Auxiliary	78dB 100dB 100dB 100dB
Output Level and Impedance	Tape 1, 2	150mV/600ohm
GENERAL		
Power Requirements		110/220 V AC ±10% 460W/552VA
Dimensions (WxDxH)		17-1/2"x14-13/16"x5-15/16"
Weight		31.9 lbs.

Because Fisher products are subject to continuous improvement, Fisher reserves the right to modify, change, or alter any design or specifications without notice and without incurring any obligation. Fisher reserves the right to make changes and improvements upon its products without any obligation to install such changes upon any of its products previously manufactured.

FUNCTIONAL BLOCK DIAGRAM

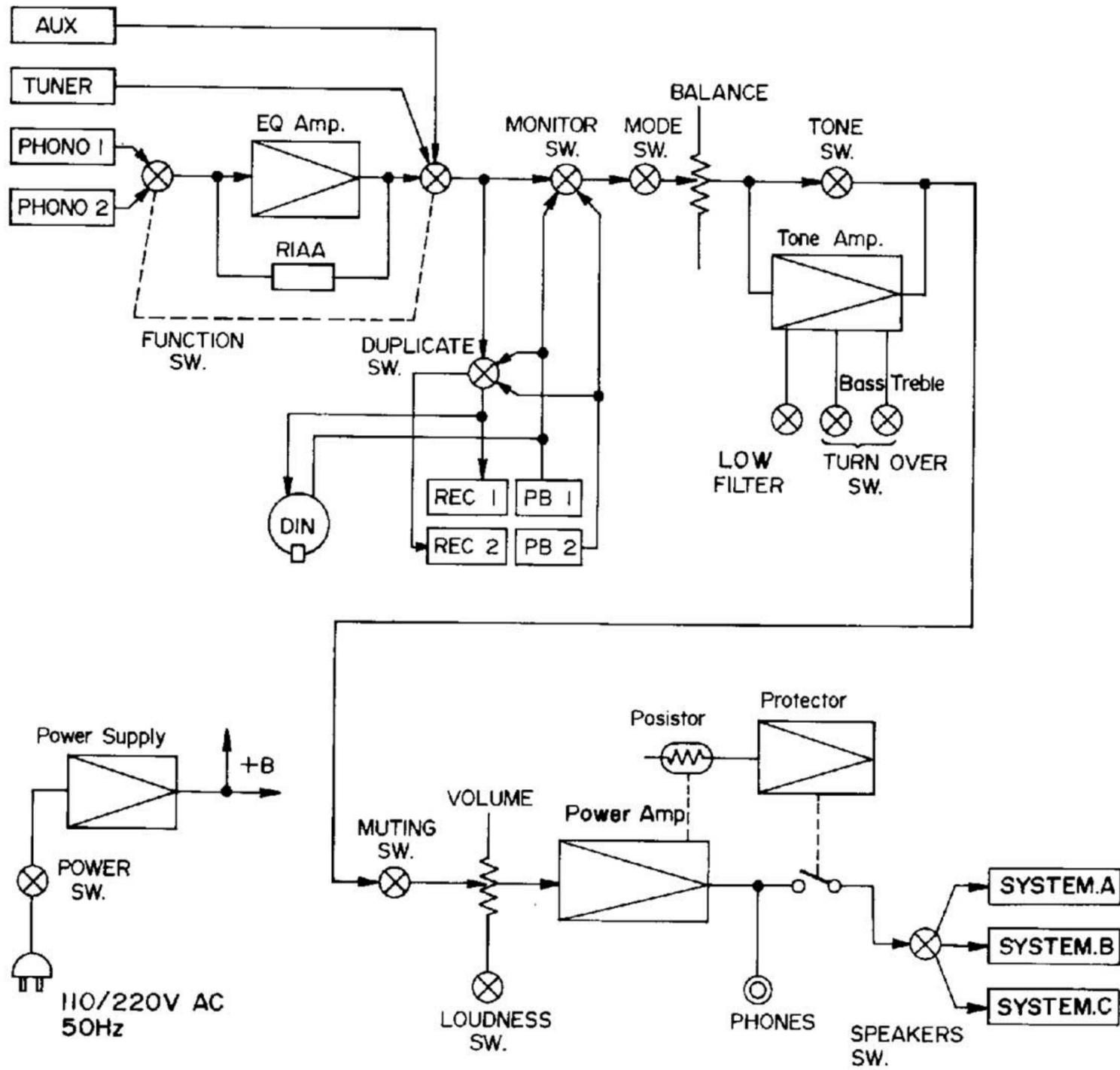

tone AMP IC NJM4558 EQUIVALENT CIRCUIT

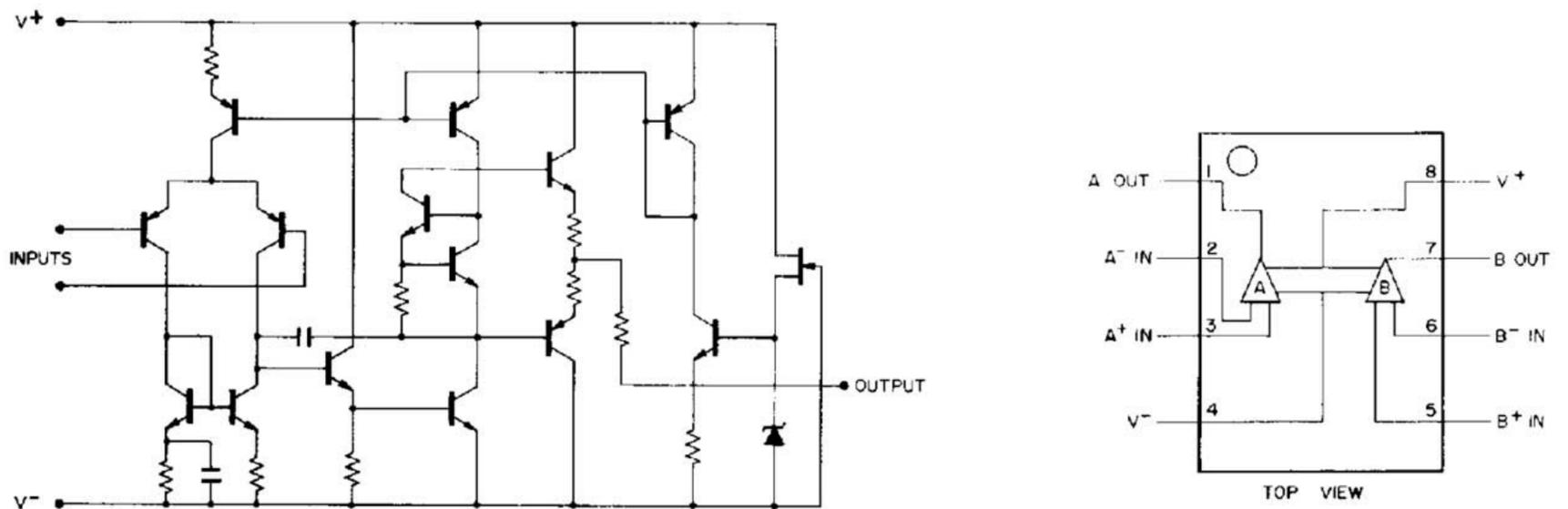

EQ AMP P.C. BOARD

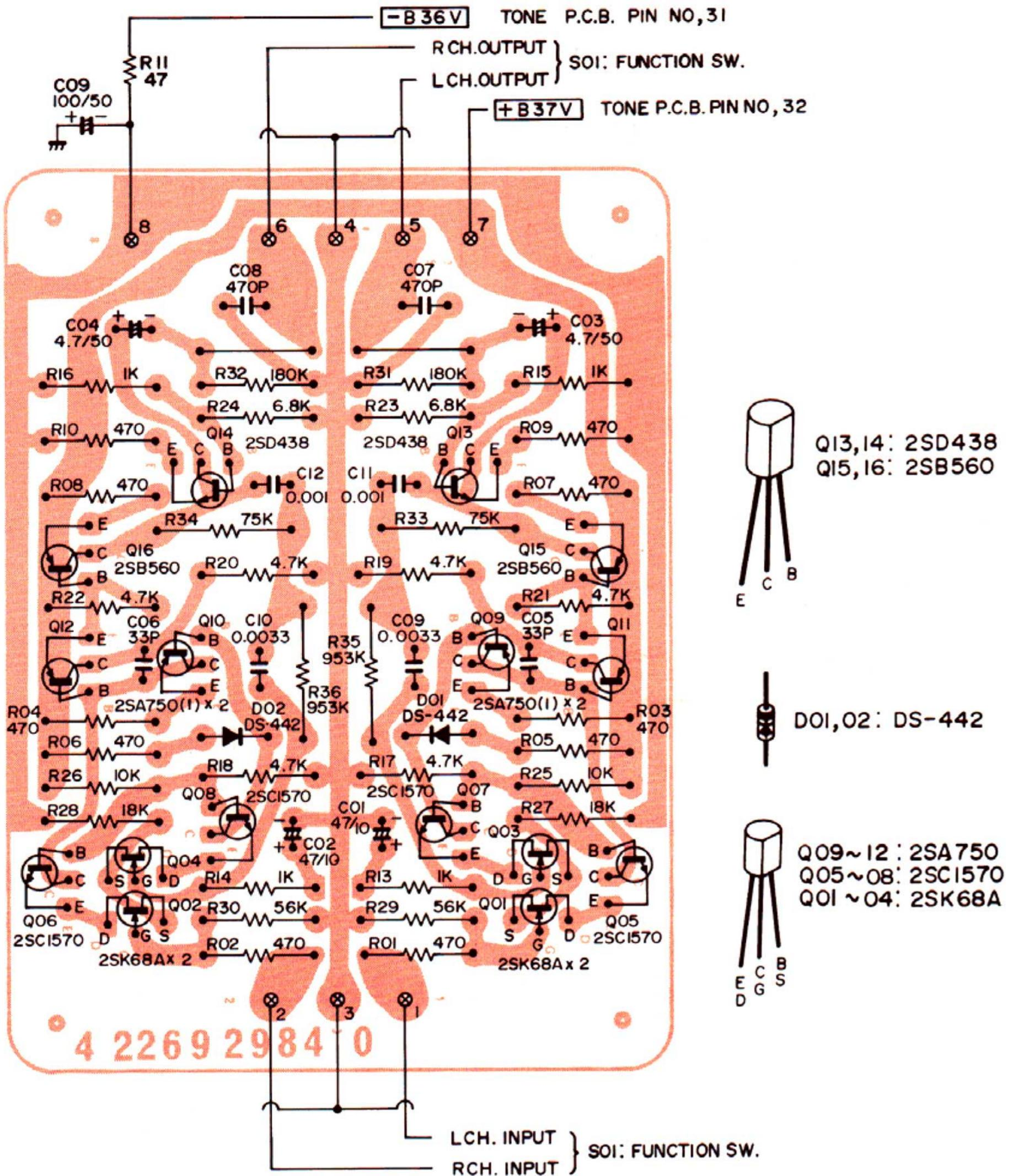

BOTTOM VIEW

TRANSISTOR DC VOLTAGES				
SYMBOL NO.	DEVICE	B, S	C, G	E, D
Q01, 02	2SK68A	0V	-22.5V	
Q03, 04	2SK68A	0V	-22.5V	
Q05, 06	2SC1570	+11.5V	+31.3V	
Q07, 08	2SC1570	+11.5V	+34.8V	
Q09, 10	2SA750	+34.8V	+31.3V	+34.8V
Q11, 12	2SA750	+31.3V	+14.5V	+31.9V
Q13, 14	2SD438	-31.0V	0V	-31.6V

LOUDNESS & MUTING/VOLUME P.C.BOARD

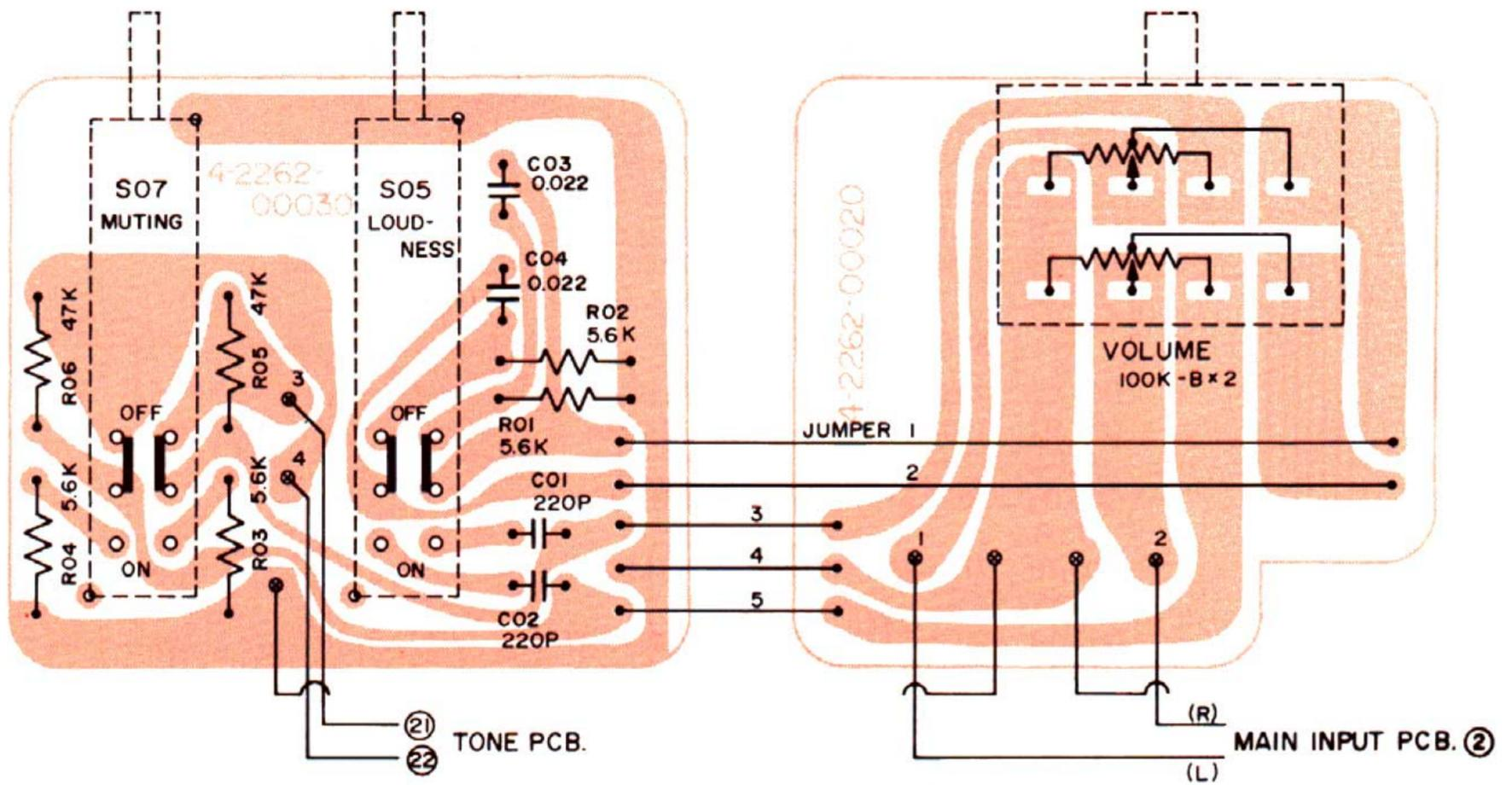

PROTECTOR P.C.BOARD

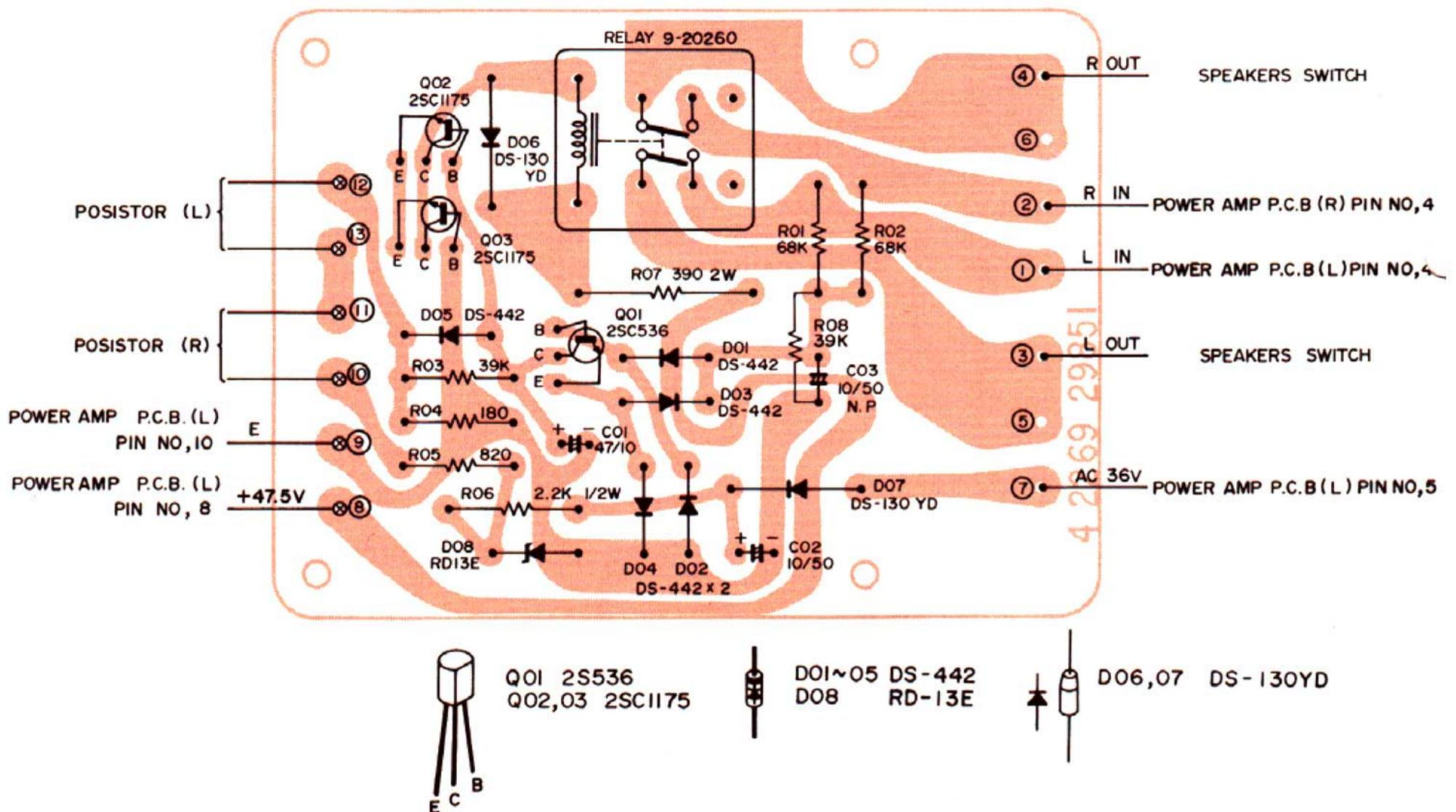

BOTTOM VIEW

TONE AMP P.C.BOARD(1/2)

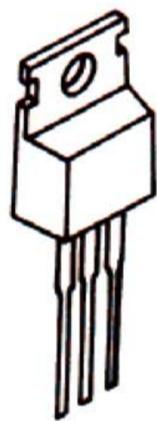
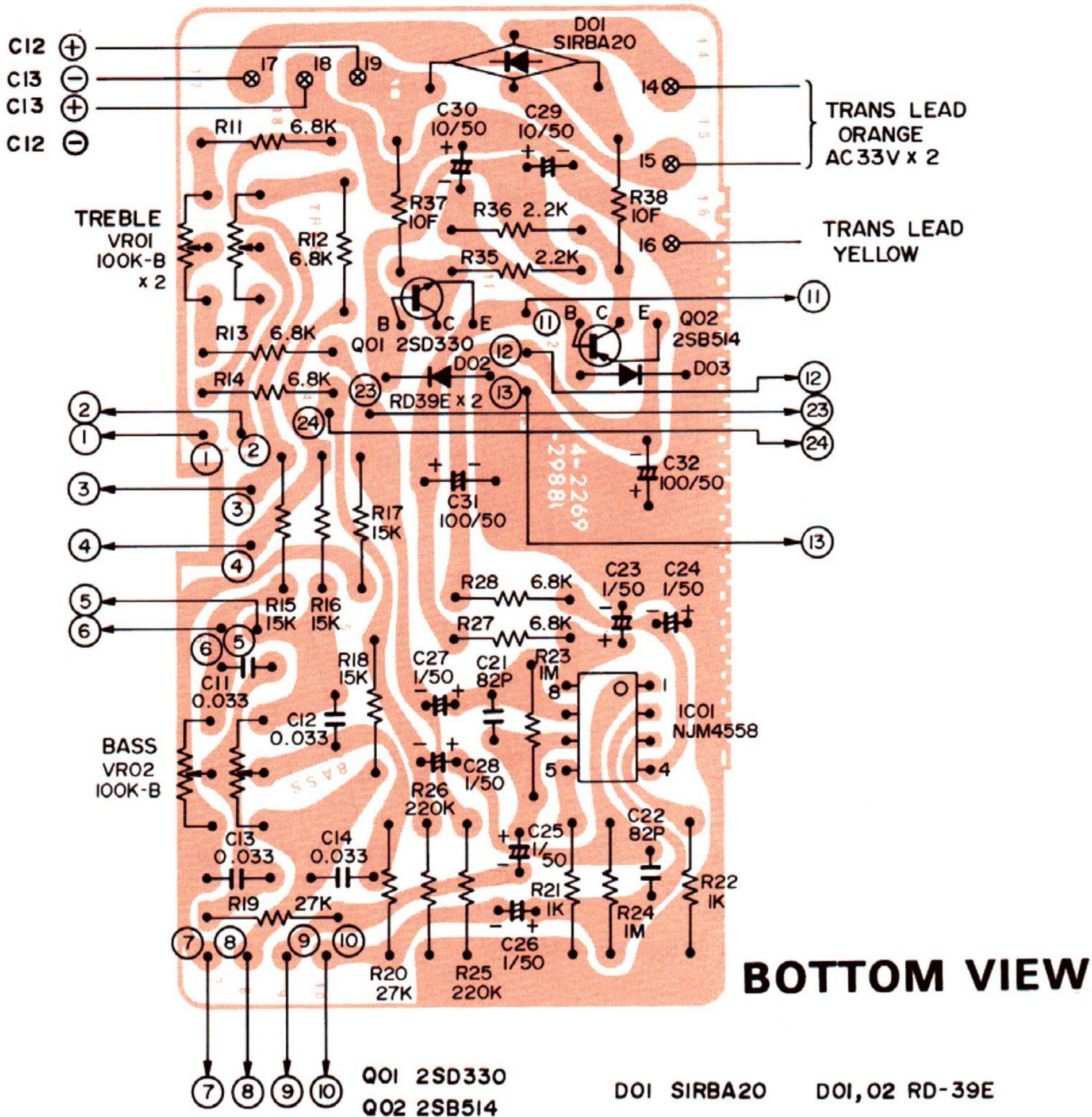

TONE AMP IC PIN NUMBERS VOLTAGES									
DEVICE	IC PIN NO.	1	2	3	4	5	6	7	8
IC NJM4558P		0V	0V	0V	-13V	0V	0V	0V	+13V

tone amp & turn over switch p.c.board

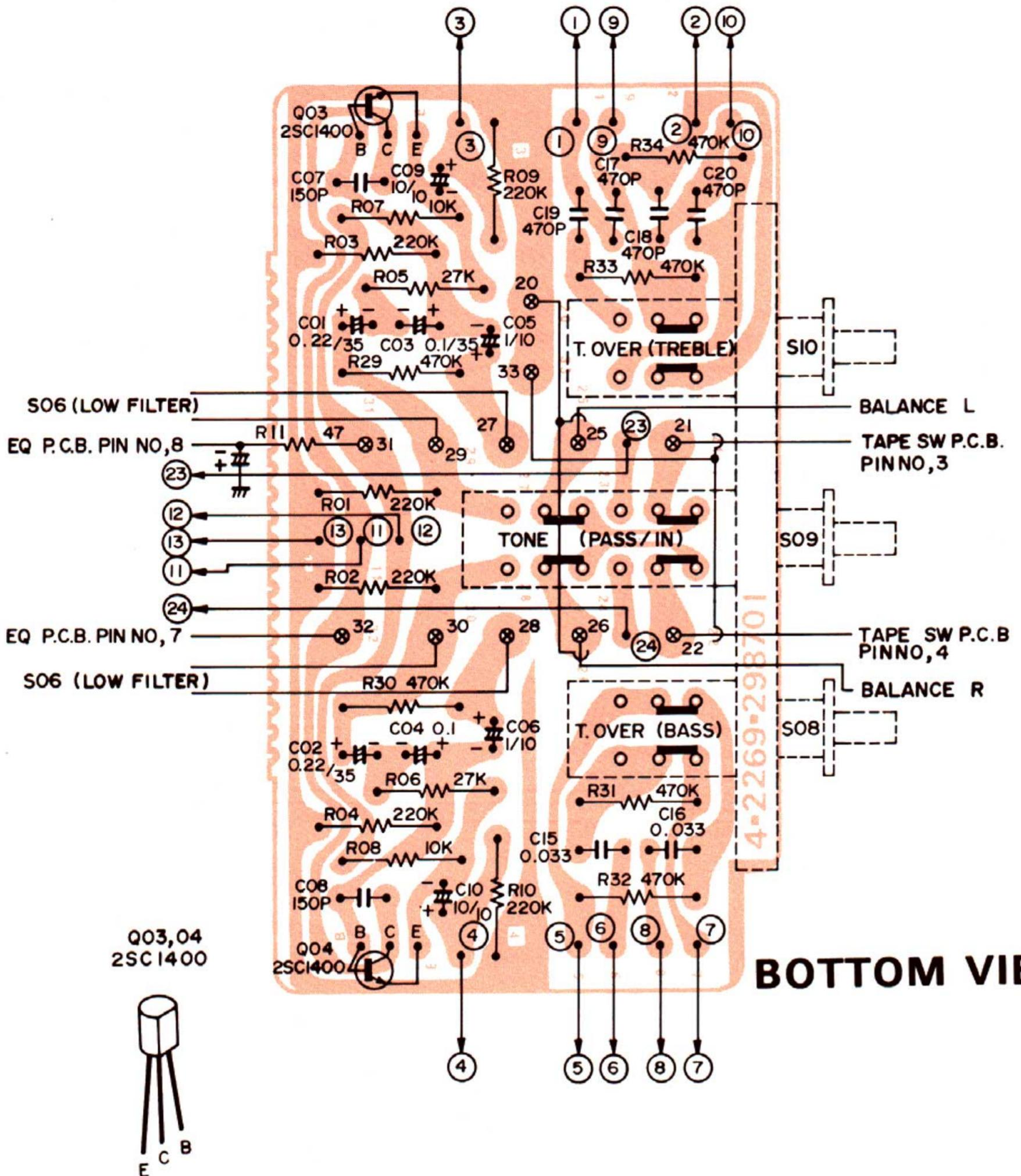

BOTTOM VIEW

TRANSISTOR DC VOLTAGES				
SYMBOL NO.	DEVICE	B	C	E
Q01	2SD330	+37.6V	+45.0V	+37.0V
Q02	2SB514	-37.6V	-45.0V	-37.0V
Q03, 04	2SC1400	-0.8V	+36.0V	-1.5V

ADJUSTMENT OF THE POWER AMP. P.C. BOARD

BEFORE ADJUSTMENT

1. Unsolder the PRE OUT/MAIN IN lead.
2. After the power switch is turned ON, allow a few minutes before making adjustment, to be sure of the most stable operation.
3. Connect dummy load resistors (8 ohms) to the speaker terminals.
4. Use a DC V.T.V.M. (Input impedance: More than 50k ohms/V).

(A) IDLING CURRENT ADJUSTMENT

Adjust VR 01 (330 ohm) for an idling current of 35 mA. Measure the voltage at both sides of R21 resistor(0.47 ohm) and adjust VR01 (330 ohm) to indicate $0.018V \pm 0.001V$.
Note: Polarity of Emitter of Q10 is (+).
Mid-point is (-).

(B) Repeat steps A for optimum results.

- Note: a. Turn the semi-fixed variable resistor slowly during adjustment.
b. Be careful of the polarity of each measurement point.

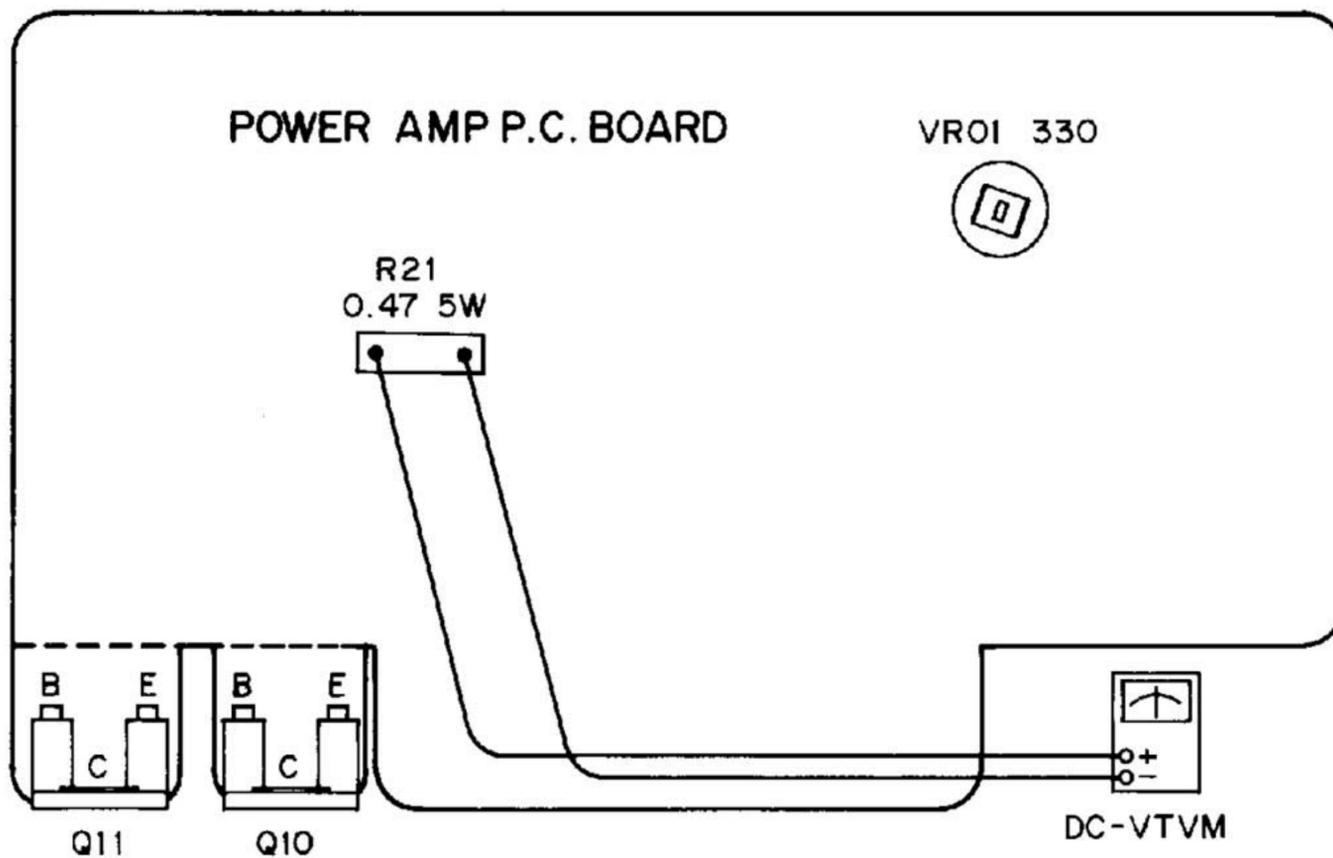

EXPLANATION OF PROTECTIVE CIRCUITS

* For about two seconds after the power switch is turned on, the speakers remain silent because the power muting circuit operates during this time.

* If this unit is operated with speakers of 4 ohm or less, or by being operated to drive two pairs of speakers of 8 ohm or less simultaneously, its power limiter will start to operate. If under these conditions the volume is raised to a high level the sound from the speakers may be distorted

* If the speaker terminals are short-circuited or the ventilation holes at the cabinet top are blocked during long periods of operation, the internal temperature may rise abnormally. At about $100^{\circ}C$, the thermal sensor (temperature detection) circuit becomes activated and will interrupt the signal. If the cause is removed and the internal temperature is back to normal, the unit automatically resets itself to restore normal operation.

POWER AMP P.C.BOARD

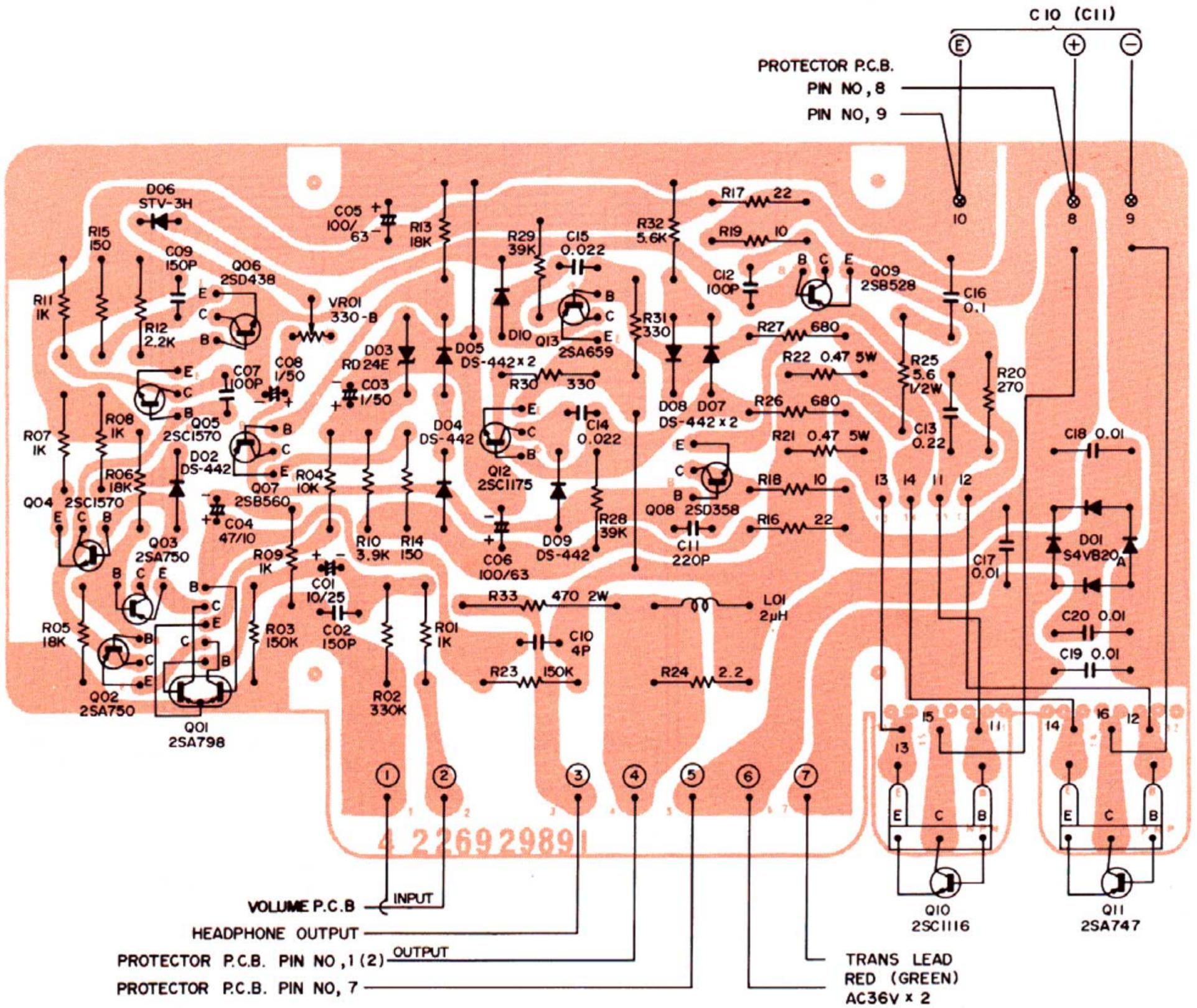

SEMICONDUCTORS FRONT VIEW

D06 STV-3H



Q06 2SD438
Q07 2SB560



Q02,03 2SA750(1)
Q04,05 2SC1570
Q12 2SC1175
Q13 2SA659



D02,04 DS442
05,07~10
D03 RD-24E



Q09 2SB528
Q08 2SD358



D01 S4VB20

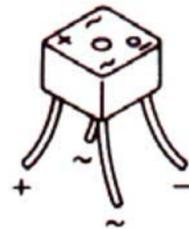

Q01 2SA798



Q11 2SA747
Q10 2SC1116



BOTTOM VIEW

POINT TO POINT WIRING DIAGRAM

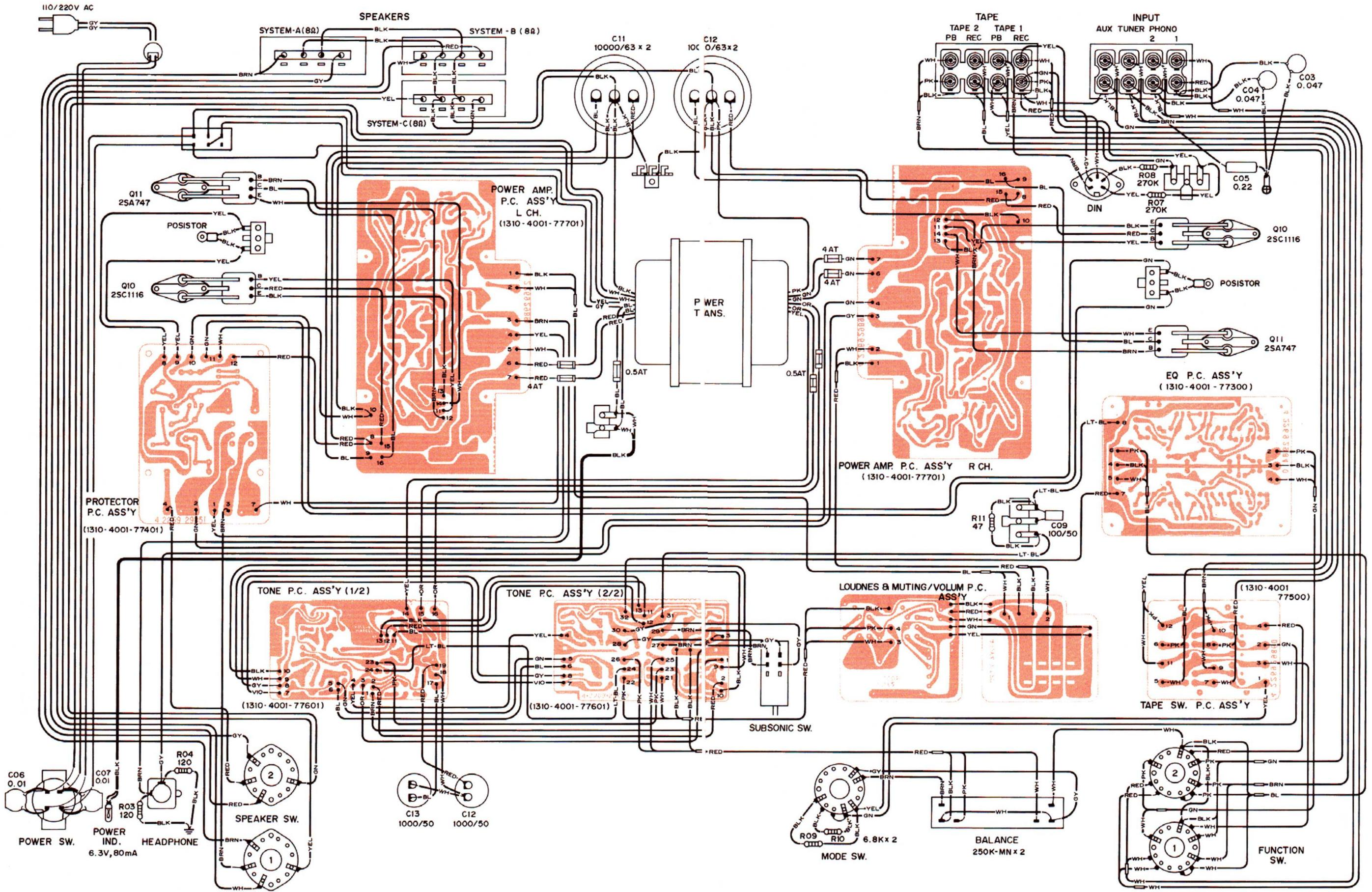

SCHEMATIC C DIAGRAM

