

Nominal Specifications for Information Only.

AMPLIFIER		CA2310
POWER AMPLIFIER SECTION		
Continuous RMS sine wave power per channel within stated bandwidth at no more than stated distortion and with an 8 ohm load		70watts
Power Band Width		20Hz-20kHz
Total Harmonic Distortion		0.05%
IM Distortion		0.05%
Speaker Damping		40
PREAMPLIFIER SECTION		
Frequency Response	Phono (30Hz-15kHz) Aux (20Hz-20kHz)	±1.0dB ±1.0dB
Input Sensitivity and Impedance	Phono 1	2mV/50k ohm
	Phono 2	2mV/50k ohm
	Tape Monitor 1	150mV/100k ohm
	Tape Monitor 2	150mV/100k ohm
	Tuner Auxiliary	150mV/100k ohm 150mV/100k ohm
Phono Max. Input Capability		220mV
Tone Control	Bass (100Hz) Treble (10kHz) Turnover (Bass) Turnover (Treble)	±10dB ±10dB 200Hz/400Hz 3kHz/6kHz
Filter	Low at 16Hz (12dB/Oct.)	10dB
Loudness Contour (100Hz/10kHz)		+8dB/+4dB
Hum and Noise (IHF Short Circuit, A Net Work)	Phono 1, 2	78dB
	Tape Monitor	100dB
	Tuner	100dB
	Auxiliary	100dB
Output Level and Impedance	Tape 1, 2	150mV/600ohm
GENERAL		
Power Requirements		110/220 V AC ±10% 460W/552VA
Dimensions (WxDxH)		17-1/2"x14-13/16"x5-15/16"
Weight		31.9 lbs.

Because Fisher products are subject to continuous improvement, Fisher reserves the right to modify, change, or alter any design or specifications without notice and without incurring any obligation. Fisher reserves the right to make changes and improvements upon its products without any obligation to install such changes upon any of its products previously manufactured.

FUNCTIONAL BLOCK DIAGRAM

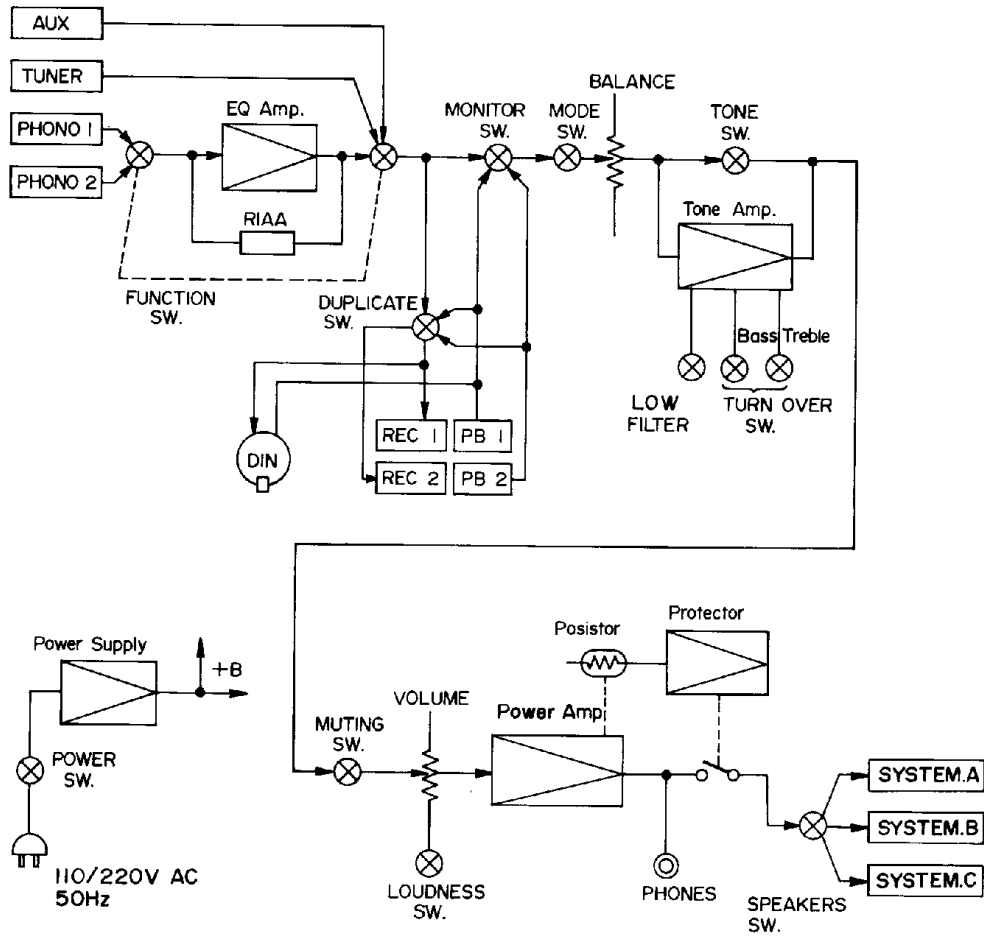

tone AMP IC NJM4558 EQUIVALENT CIRCUIT

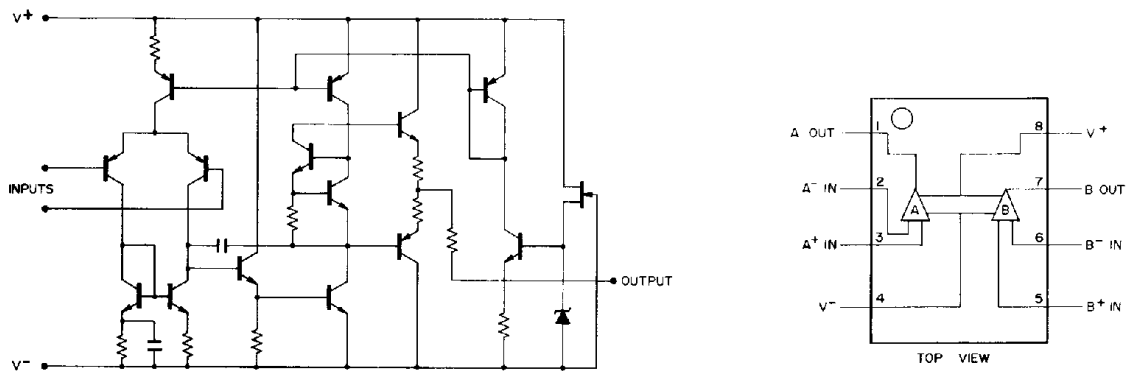

EQ AMP P.C. BOARD

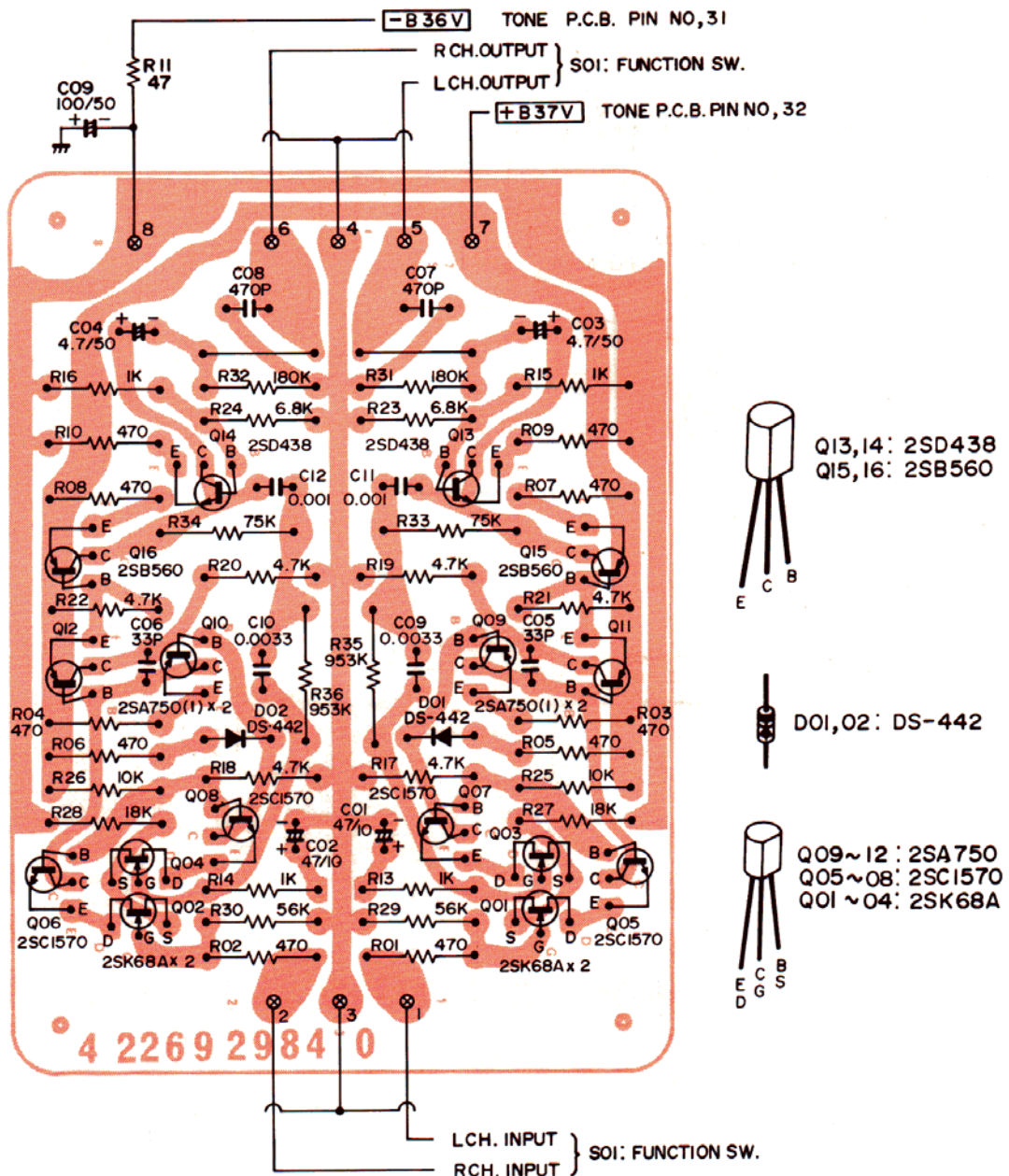

BOTTOM VIEW

TRANSISTOR DC VOLTAGES				
SYMBOL NO.	DEVICE	B, S	C, G	E, D
Q01, 02	2SK68A	0V	-22.5V	
Q03, 04	2SK68A	0V	-22.5V	
Q05, 06	2SC1570	+11.5V	+31.3V	
Q07, 08	2SC1570	+11.5V	+34.8V	
Q09, 10	2SA750	+34.8V	+31.3V	+34.8V
Q11, 12	2SA750	+31.3V	+14.5V	+31.9V
Q13, 14	2SD438	-31.0V	0V	-31.6V

LOUDNESS & MUTING/VOLUME P.C.BOARD

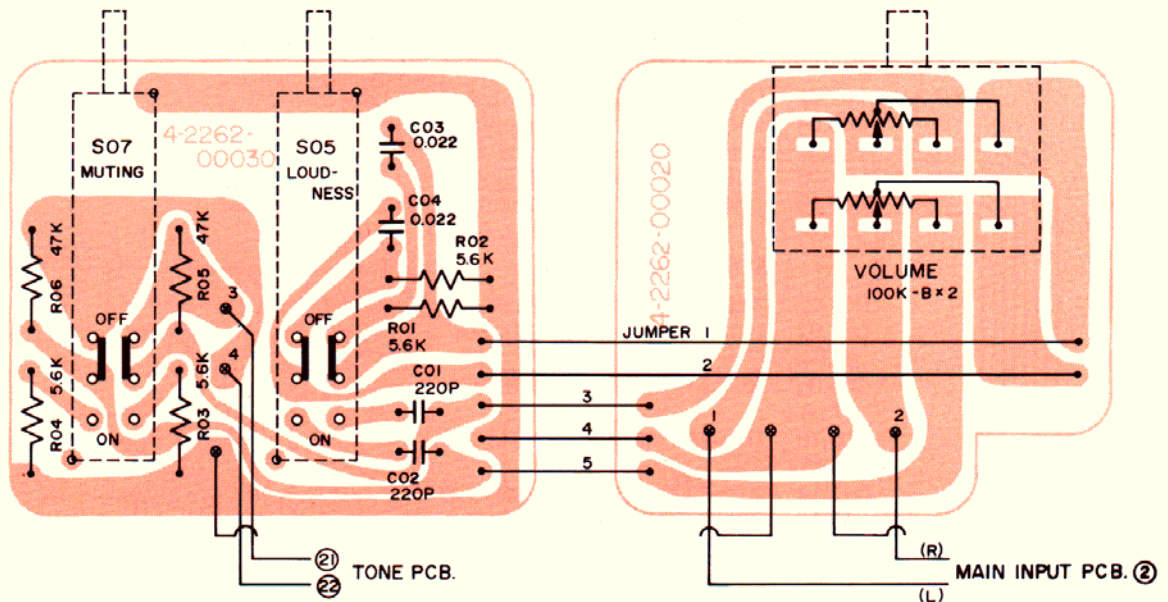

PROTECTOR P.C.BOARD

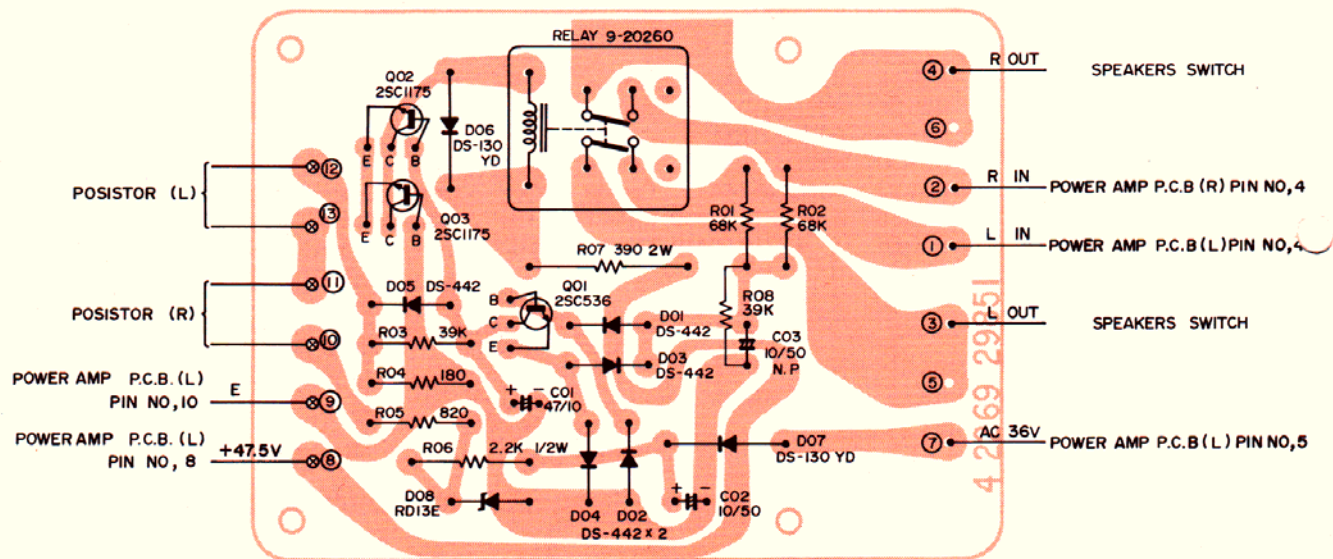

Q01 2S536
Q02,03 2SC1175



D01~05 DS-442
D08 RD-13E

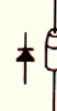

D06,07 DS-130YD

BOTTOM VIEW

TONE AMP P.C. BOARD(1/2)

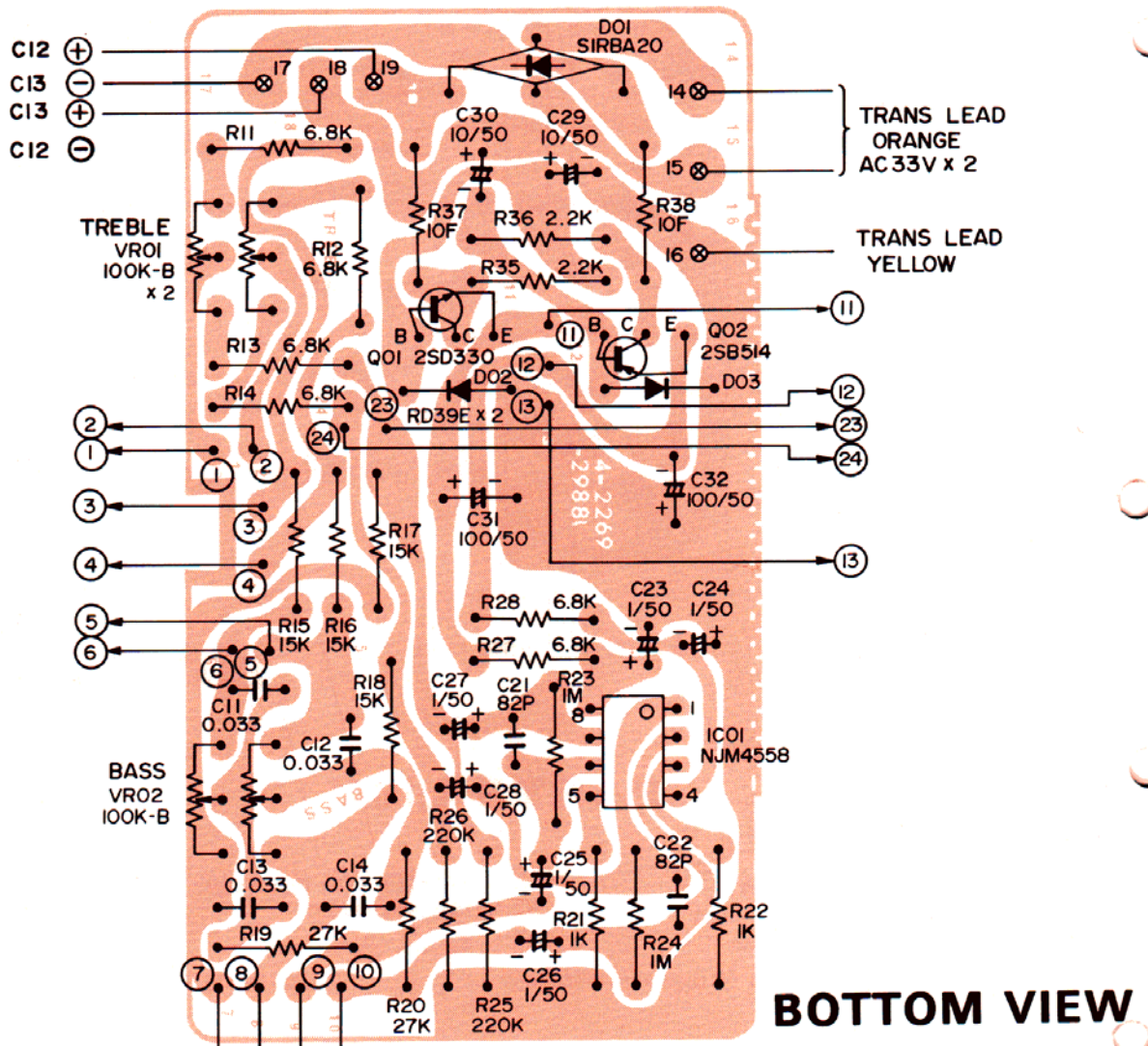

BOTTOM VIEW

- Q01 2SD330
- Q02 2SB514
- DOI SIRBA20
- DOI,02 RD-39E

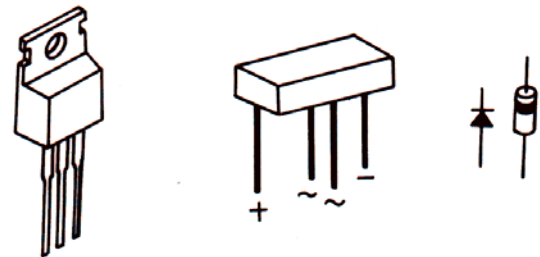

TONE AMP IC PIN NUMBERS VOLTAGES									
DEVICE	IC PIN NO.	1	2	3	4	5	6	7	8
IC NJM4558P		0V	0V	0V	-13V	0V	0V	0V	+13V

TONE AMP & TURN OVER SWITCH P.C.BOARD(2)

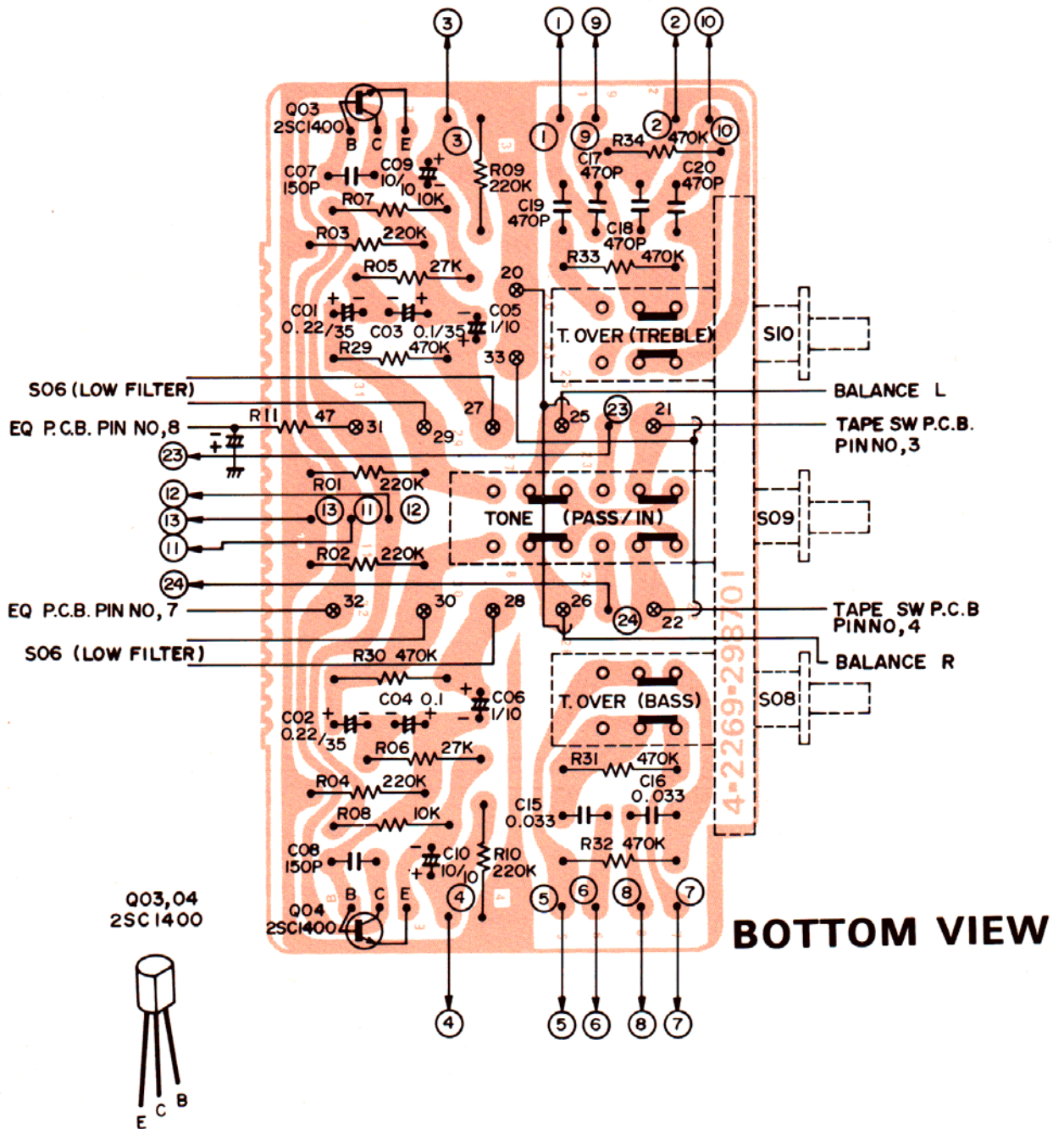

TRANSISTOR DC VOLTAGES				
SYMBOL NO.	DEVICE	B	C	E
Q01	2SD330	+37.6V	+45.0V	+37.0V
Q02	2SB514	-37.6V	-45.0V	-37.0V
Q03, 04	2SC1400	-0.8V	+36.0V	-1.5V

ADJUSTMENT OF THE POWER AMP. P.C. BOARD

BEFORE ADJUSTMENT

1. Unsolder the PRE OUT/MAIN IN lead.
2. After the power switch is turned ON, allow a few minutes before making adjustment, to be sure of the most stable operation.
3. Connect dummy load resistors (8 ohms) to the speaker terminals.
4. Use a DC V.T.V.M. (Input impedance: More than 50k ohms/V).

(A) IDLING CURRENT ADJUSTMENT

Adjust VR 01 (330 ohm) for an idling current of 35 mA. Measure the voltage at both sides of R21 resistor(0.47 ohm) and adjust VR01 (330 ohm) to indicate $0.018V \pm 0.001V$.
Note: Polarity of Emitter of Q10 is (+).
Mid-point is (-).

(B) Repeat steps A for optimum results.

Note: a. Turn the semi-fixed variable resistor slowly during adjustment.
b. Be careful of the polarity of each measurement point.

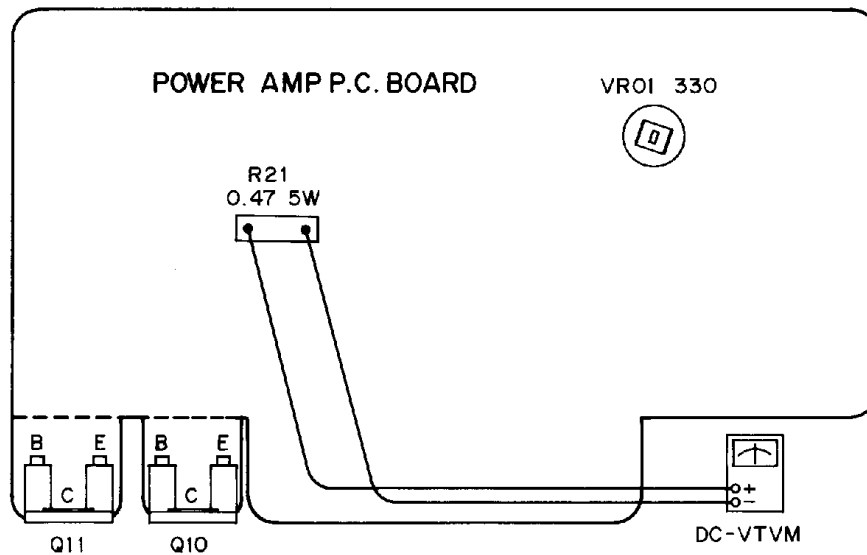

EXPLANATION OF PROTECTIVE CIRCUITS

* For about two seconds after the power switch is turned on, the speakers remain silent because the power muting circuit operates during this time.

* If this unit is operated with speakers of 4 ohm or less, or by being operated to drive two pairs of speakers of 8 ohm or less simultaneously, its power limiter will start to operate. If under these conditions the volume is raised to a high level the sound from the speakers may be distorted

* If the speaker terminals are short-circuited or the ventilation holes at the cabinet top are blocked during long periods of operation, the internal temperature may rise abnormally. At about 100°C, the thermal sensor (temperature detection) circuit becomes activated and will interrupt the signal. If the cause is removed and the internal temperature is back to normal, the unit automatically resets itself to restore normal operation.

POWER AMP P.C.BOARD

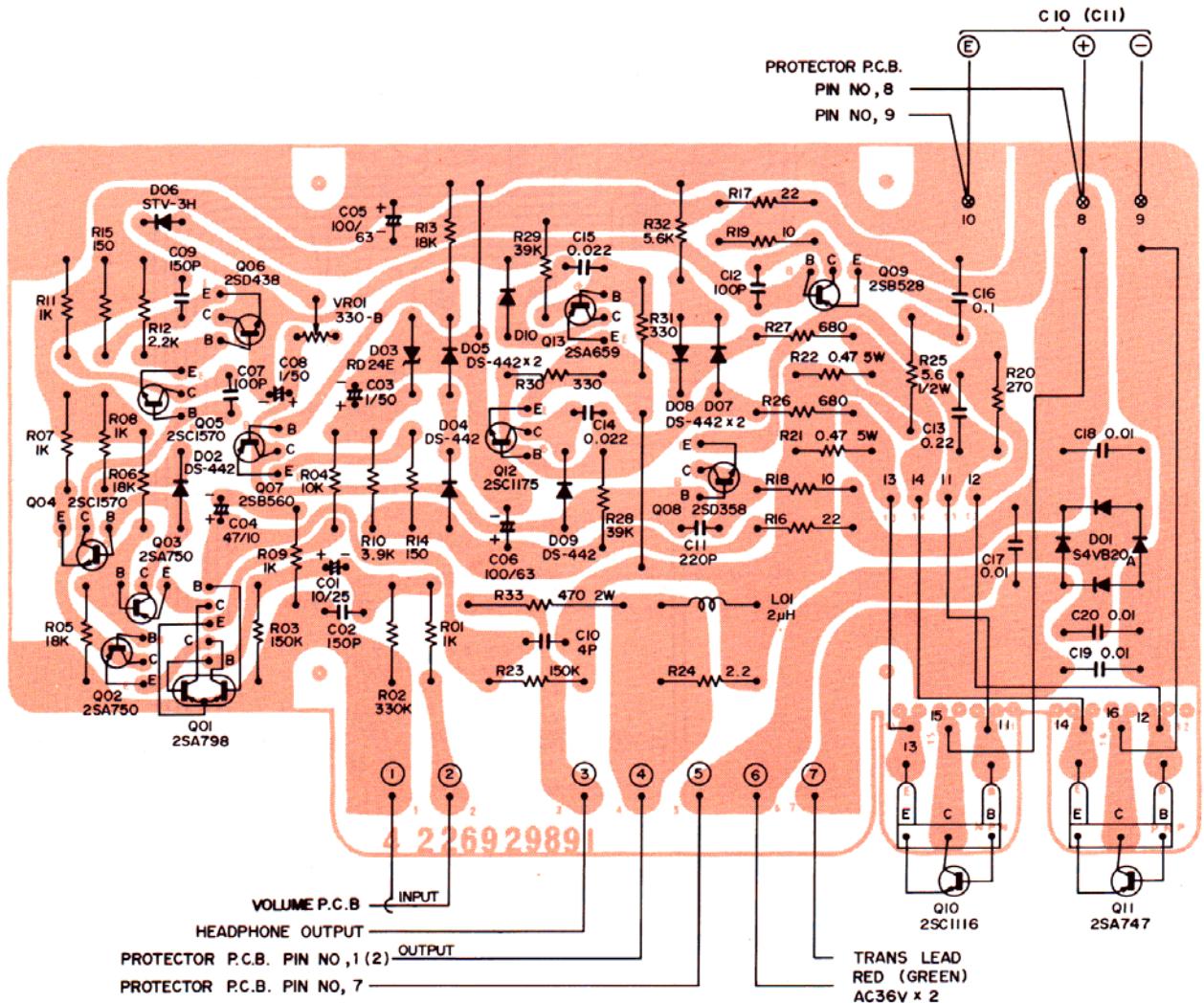

SEMICONDUCTORS FRONT VIEW

D06 STV-3H



Q06 2SD438
Q07 2SB560



Q01 2SA798



Q02, Q03 2SA750(1)
Q04, Q05 2SC1570
Q12 2SC1175
Q13 2SA659



D02, D04 DS442
05, 07 ~ 10
D03 RD-24E



Q09 2SB528
Q08 2SD358



BOTTOM VIEW

D01 S4VB20



Q11 2SA747
Q10 2SC1116



POINT TO POINT V

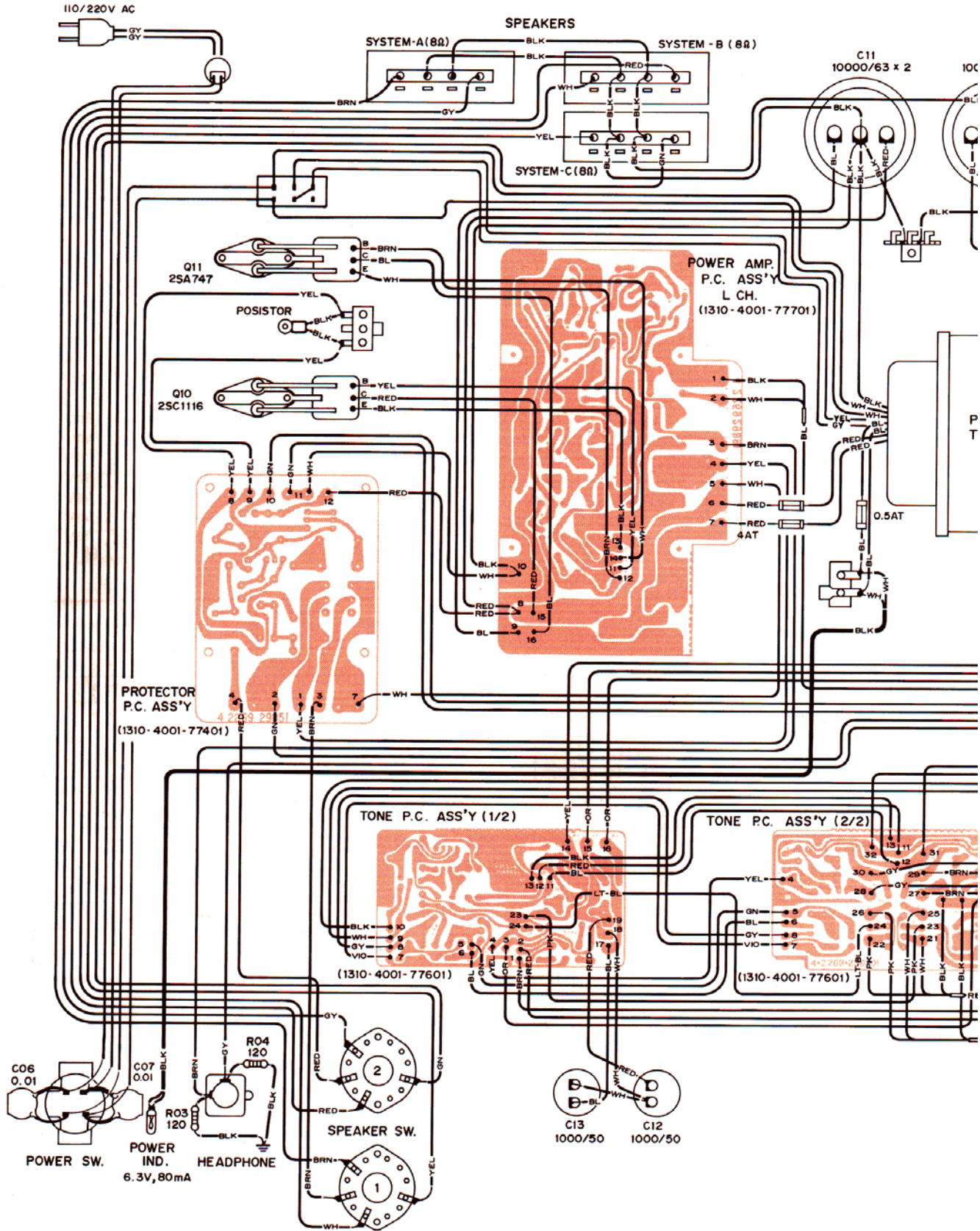

WIRING DIAGRAM

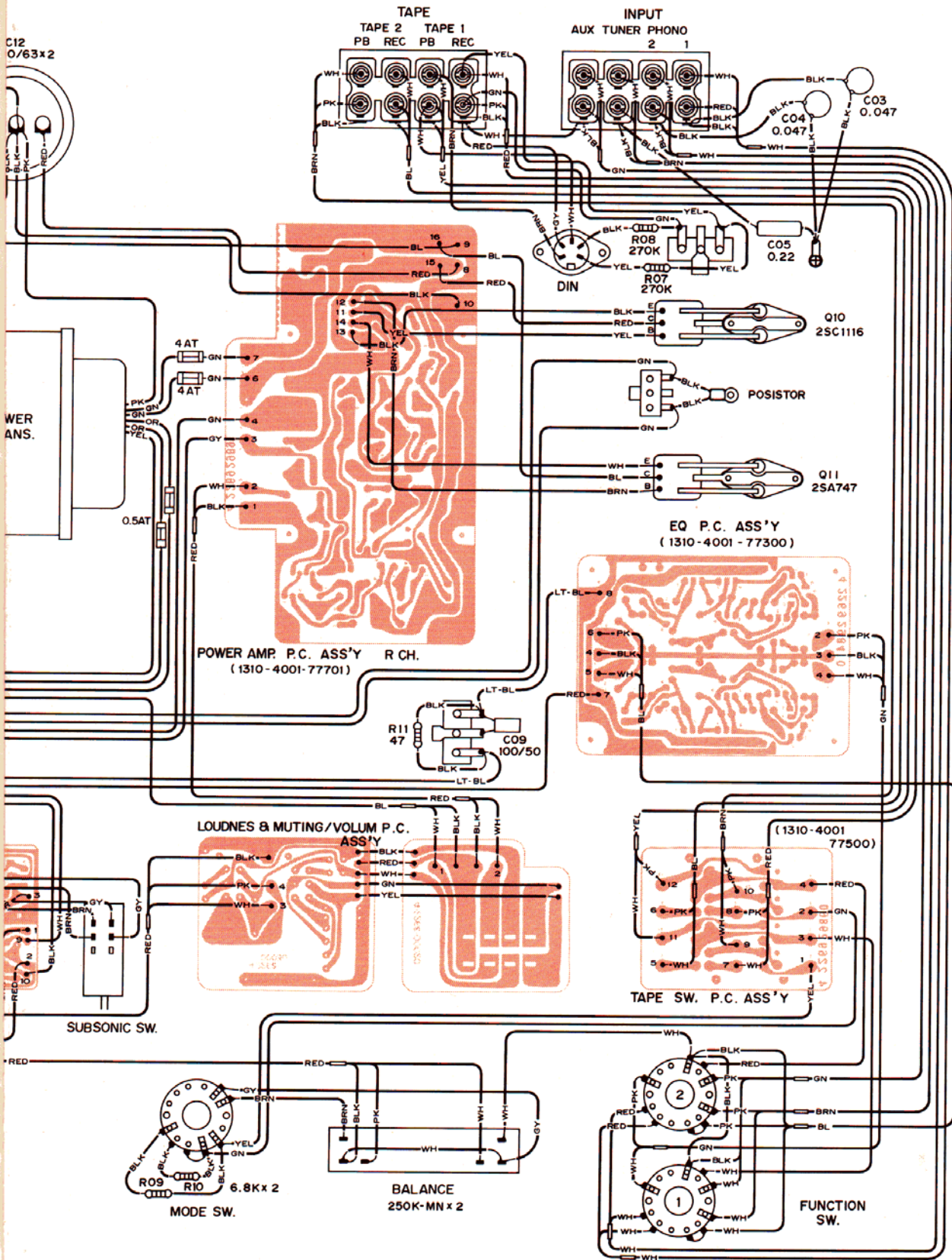

SCHEMATIC

Q 01 ~ 04 2SK68A Q 15, 16 2SB560
 Q 05 ~ 08 2SC1570 L D 01, 02 DS-442
 Q 09 ~ 12 2SA750 (1) Q 13, 14 2SD438

IC 01 NJM4
 Q 01 2SD3

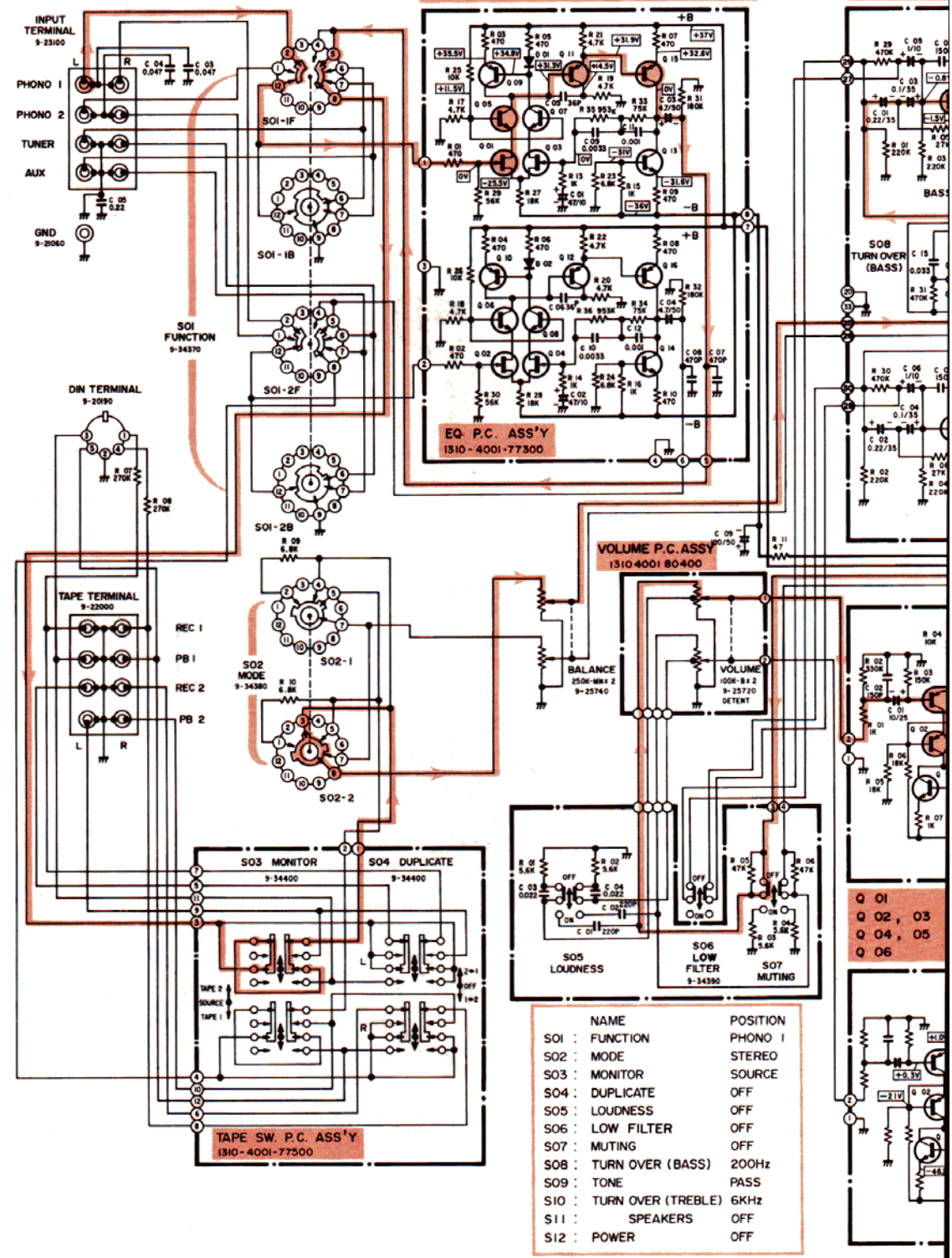

NAME	POSITION
SO1 : FUNCTION	PHONO 1
SO2 : MODE	STEREO
SO3 : MONITOR	SOURCE
SO4 : DUPLICATE	OFF
SO5 : LOUDNESS	OFF
SO6 : LOW FILTER	OFF
SO7 : MUTING	OFF
SO8 : TURN OVER (BASS)	200Hz
SO9 : TONE	PASS
SO10 : TURN OVER (TREBLE)	6KHz
SO11 : SPEAKERS	OFF
SO12 : POWER	OFF

C DIAGRAM

3D Q 02 25B514 D 01 SIRBA20
 Q 03, 304 25C1400 D 02, 303 RD39E

