

SERVICE MANUAL

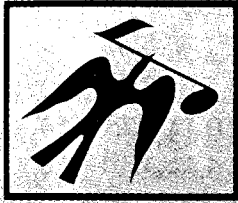

FISHER

CA-270

**Integrated
Stereo Amplifier
(EUROPE)**



132 287 41

CONTENTS

Functional Block Diagram	2
Specifications	3
Cabinet & Chassis Exploded View	4,5
Parts List	6
Recommended Test Equipments	7
Harmonic Distortion Test	7
Power Amplifier Adjustment	8
Integrated Circuit Block Diagram	8,9
P.C.B.Assy Parts List	10,11,12,13,14
Printed Circuit Board (Bottom View)	14,15,16,17,18
Point to Point Wiring Diagram	19,20
Schematic Diagram	21,22
Semiconductor Lead Identification	23

FUNCTIONAL BLOCK DIAGRAM

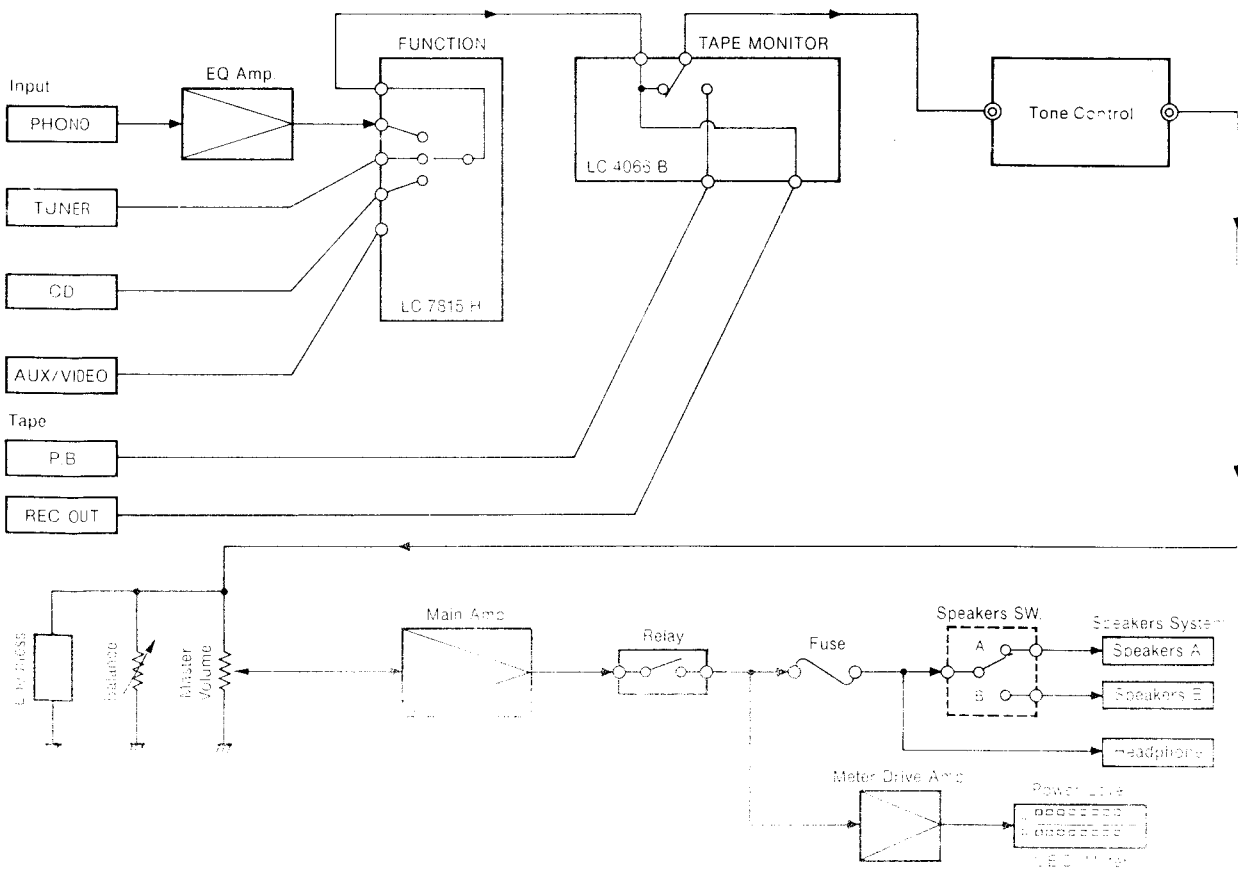

SPECIFICATIONS

AMPLIFIER	CA-270
POWER AMPLIFIER SECTION Minimum RMS sine wave power per channel within stated bandwidth at no more than stated distortion and with 8-ohm load	100 Watts
Power Bandwidth	20 Hz – 20 kHz
Total Harmonic Distortion	0.05 %
I.M. Distortion	0.05 %
Speaker Damping	> 20
PREAMPLIFIER SECTION Frequency Response	
Phono (RIAA)	±1 dB
Aux (20 Hz – 20 kHz)	±1 dB
Input Sensitivity and Impedance	
Phono	2.5 mV/50 kΩ
Tape Monitor	150 mV/50 kΩ
Tuner/Auxiliary	150 mV/50 kΩ
Phono Max. Input Capability	
Phono	125 mV
Tone Controls	
Bass (100 Hz)	±10 dB
Treble (10kHz)	±10 dB
Loudness Contour (100 Hz/10 kHz)	+8 dB/+4 dB
Hum & Noise (IHF Short Circuit, A Network)	
Phono	70 dB
Tape Monitor	90 dB
Tuner/Auxiliary	90 dB
GENERAL Power Requirements (50 Hz)	110 / 120 V AC
Power Consumption	480 Watts
Dimensions (W x H x D)	440 x 270 x 110 mm
Weight (approx.)	8.4 kg

Because its products are subject to continuous improvement, Fisher Corporation reserves the right to modify product designs and specifications without notice and without incurring any obligation.

CABINET & CHASSIS EXPLODED VIEW (1)

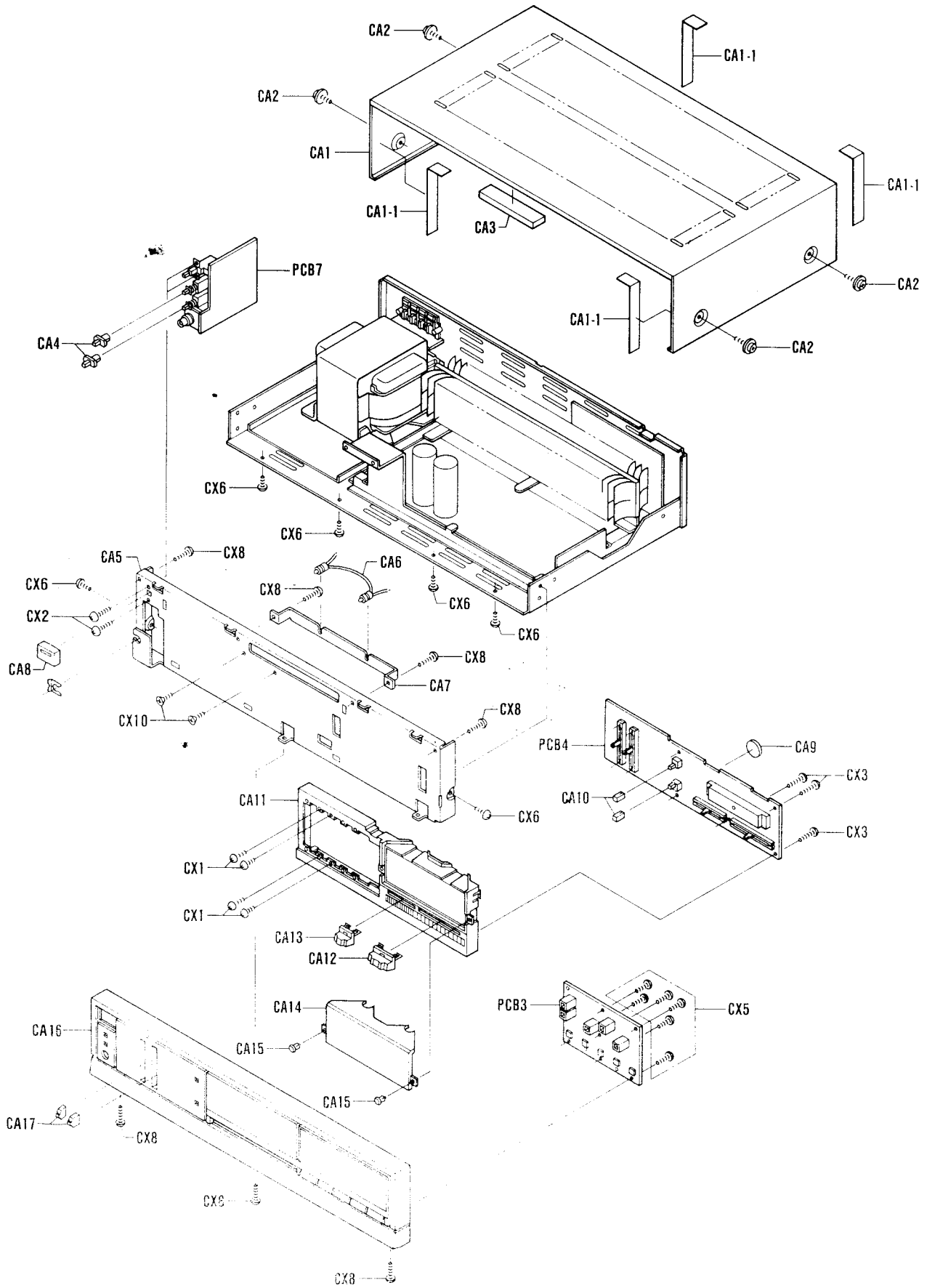

CABINET & CHASSIS EXPLODED VIEW (2)

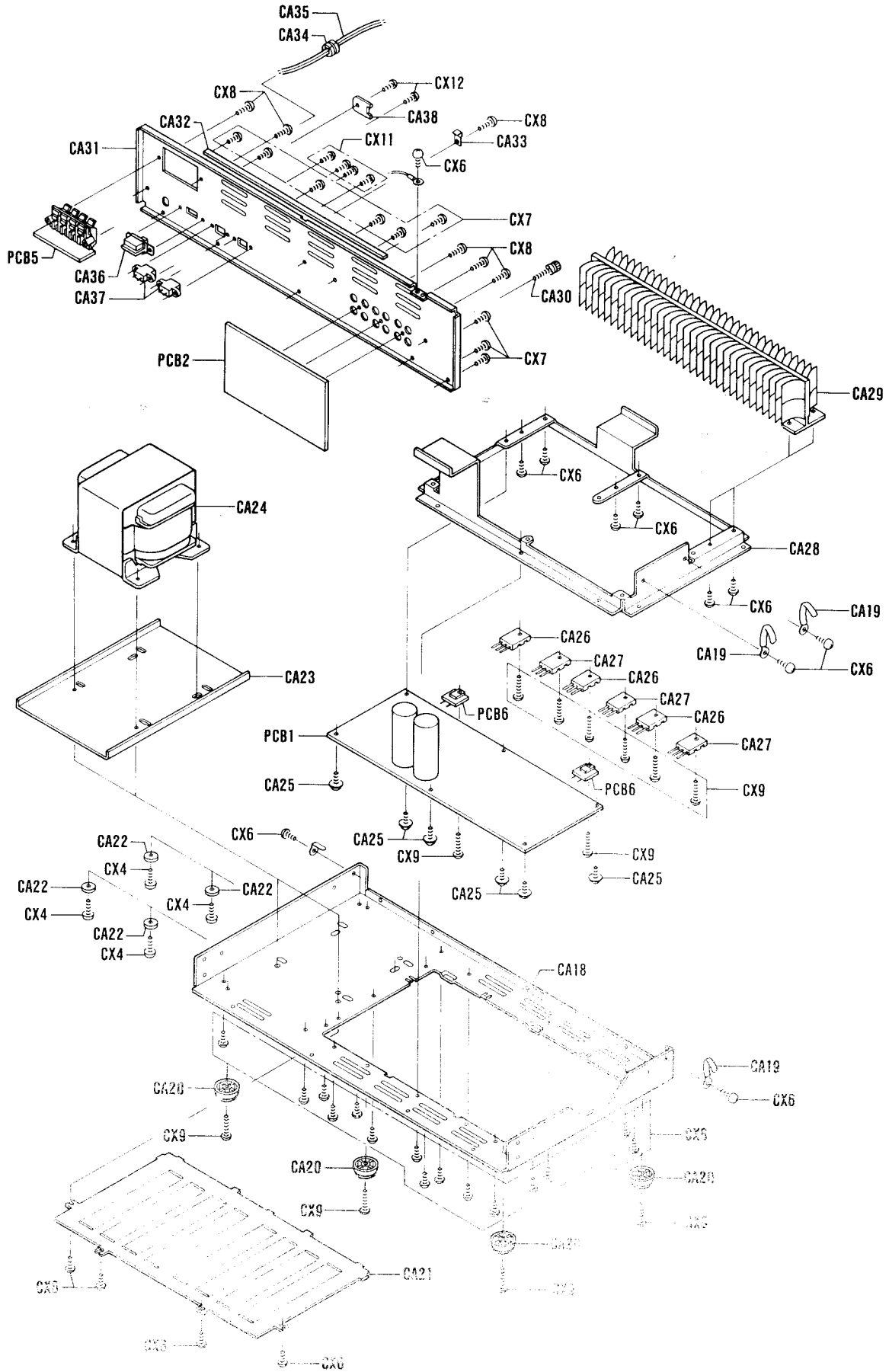

PARTS LIST

Ref. No.	Part No.	Description	Q'ty	Ref. No.	Part No.	Description	Q'ty
PACKING PARTS LIST				CA29	141-2-3689-14300	Plate Heat Sink	1
	3-9415-10300	Bag Polyethylene	1	CA30	131-2-4201-17800	Screw Ground	1
	131-6-2119-02090	Bag Polyethylene-Exp.	1	CA31	141-2-1219-34801	Panel Rear	1
	131-6-3069-16350	Patching Sheet	1	CA32	131-2-5205-15800	Cushion	1
	131-6-9459-00300	Rubber Band	1	CA33	141-2-3159-03300	Bracket Cover	1
	141-6-1139-86227	Outer Cor Carton	1	CA34	131-2-6111-14200	Bushing (Power Cord)	1
	141-6-1469-00400	Pad Top	1	CA35	△ 4-2432-00200	Power Cord	1
	141-6-1469-04000	Case Styrofoam (Left)	1	CA36	△ 4-2312-01020	Switch Slide (AC Selector) [SW411]	1
	141-6-1469-04001	Case Styrofoam (Right)	1	CA37	△ 4-2359-74032	2P Socket With/Nut	2
	141-6-4559-03300	Serial No. Sheet	1	CA38	131-2-7104-00500	Plate Pad Switch	1
ACCESSORIES PARTS LIST				P.C.B. ASSY PARTS LIST			
	131-6-2719-10801	Bag Fan	1	PCB1	141-0-1939-09162	Main P.C.B. Assy	1
	131-6-4519-15700	Guarantee Certificate	1	PCB2	141-0-1939-09131	Input P.C.B. Assy	1
	131-6-4559-11200	Serial No. Sheet	1	PCB3	141-0-1939-09140	Function P.C.B. Assy	1
	142-6-4119-32454	Explanatory Booklet	1	PCB4	141-0-1939-09151	Tone Control P.C.B. Assy	1
CABINET & CHASSIS PARTS LIST				PCB5	141-0-1939-09172	Speaker Terminal P.C.B. Assy	1
	4-2379-21520	Terminal Lug	2	PCB6	141-0-1939-09180	Transistor P.C.B. Assy	2
	131-2-7103-26100	Label	1	PCB7	141-0-1939-09192	Switch P.C.B. Assy	1
	141-2-1219-03300	Serial No. Sheet	1	SCREW PARTS LIST			
	131-6-4559-10900	Manufacturing No.	1	CX1	101-3-1302-00311	Screw, Pan Hd. +M2.0x3	4
CA1	131-2-1410-33100	Cover	1	CX2	101-3-1303-00611	Screw, Pan Hd. +M3.0x6	2
CA1-1	131-2-3202-13400	Metal Reinf	4	CX3	143-3-1302-60611	Screw, Pan Hd. Tapping-B, +M2.6x6	3
CA2	141-2-4219-38400	Screw, Bind Hd. Tapping-B Sems +M4.0x8	4	CX4	143-3-1704-00811	Screw, Bind Hd. Tapping-B, +M4.0x8	4
CA3	131-2-5205-33300	Cushion	1	CX5	143-3-1902-60611	Screw, Brazier Hd. Tapping-B, +M2.6x6	6
CA4	131-2-1601-69601	Knob (Speaker Selector)	2	CX6	143-3-1903-00611	Screw, Brazier Hd. Tapping-B, +M3.0x6	36
CA5	141-2-2149-24300	Panel Front	1	CX7	143-3-1903-00618	Screw, Brazier Hd. Tapping-B, +M3.0x6	9
CA6	4-6129-70660	Lamp	1	CX8	143-3-1903-00818	Screw, Brazier Hd. Tapping-B, +M3.0x8	13
CA7	131-2-3310-18000	Metal Mount Lamp	1	CX9	143-3-1903-01011	Screw, Brazier Hd. Tapping-B, +M3.0x10	12
CA8	131-2-1601-91600	Knob Power	1	CX10	143-3-1203-00611	Screw, Flat Hd. Tapping-B, +M3.0x6	2
CA9	131-2-5205-33500	Cushion	1	CX11	101-3-1302-60618	Screw, Pan Hd., +M2.6x6	4
CA10	131-2-1601-91700	Knob Push	2	CX12	101-3-1303-00618	Screw, Pan Hd., +M3.0x6	2
CA11	141-0-3519-24400	Mount P.C.B. Assy	1	NOTES:			
	141-2-3519-74300	Mount P.C.B.	1	1. Parts order must contain Model Number, Part Number and Description.			
	141-2-1449-65100	Screen LED	1	2. Ordering quantity of screws and resistors must be multiple of 10 pcs.			
CA12	131-2-1601-91900	Knob Volume	1	<div style="border: 1px solid black; padding: 10px; text-align: center;"> <p>PRODUCT SAFETY NOTICE</p> <p>Each precaution in this manual should be followed during servicing. Components identified with the IEC symbol \triangle in the parts list and the schematic diagram designate components in which safety can be of special significance. When replacing a component identified with \triangle, use only the replacement parts designated, or parts with the same ratings of resistance, wattage or voltage that are designated in the parts list in this manual. Leakage-current or resistance measurements must be made to determine that exposed parts are acceptably insulated from the supply circuit before returning the product to the customer.</p> </div>			
CA13	131-2-1601-92000	Knob Balance	1				
CA14	131-2-3608-16400	Filter	1				
CA15	131-2-4221-00600	Rivet	2				
CA16	131-0-1016-44500	Panel Decorate Assy	1				
	131-2-1205-28800	Decorate Plate Dial	1				
	131-2-1601-91800	Knob Function	1				
	141-2-1129-15800	Cabinet Front	1				
	141-2-1449-61208	Plate Front	1				
	141-2-1449-65000	Plate Decorate	1				
	141-2-2899-43500	Adhesive Film	2				
	141-2-2899-43600	Adhesive Film	2				
CA17	141-2-1659-35900	Knob Slide	2				
CA18	141-2-3119-25400	Chassis	1				
CA19	131-0-3016-10400	Cramp Wire Assy	3				
CA20	131-2-1801-14100	Leg	4				
CA21	141-2-1259-08100	Plate Bottom	1				
CA22	131-2-4203-84200	Washer, 4.2x12x1.0 Z	4				
CA23	131-2-3101-99900	Metal Mount Trans	1				
CA24	△ 4-2512-23021	Power Trans	1				
CA25	131-2-4201-25201	Screw, Brazier Hd. Tapping-B, Sems +M3.0x8	6				
CA26	4-2039-71961	Transistor, 2SA 1302 [Q115, Q215, Q505]	3				
or	4-2039-72121	Transistor, 2SA 1301 [Q115, Q215, Q505]	3				
CA27	4-2039-71971	Transistor, 2SC 3281 [Q114, Q214, Q506]	3				
or	4-2039-72111	Transistor, 2SC 3280 [Q114, Q214, Q506]	3				
CA28	141-2-3129-05800	Sub Chassis	1				

RECOMMENDED TEST EQUIPMENTS

The following test equipments are recommended to completely test and align the Amplifier:

- Line Voltage Isolation Transformer
- AC DC Multimeter
- Accurately Calibrated AC Voltmeter
- Oscilloscope (Flat to 100 kHz Minimum)
- Low-Distortion Audio Sine-Wave Generator
- Harmonic Distortion Analyzer
- Two (2) Load Resistors 8-ohms, 250 Watts (Minimum Rating)

HARMONIC DISTORTION TEST

CAUTION: Limit the following tests to no more than ten minutes each. Use 8-ohm resistors, with a minimum power rating of 250 watts when connecting a load across the SPEAKERS terminal.

CONTROL SETTINGS:

Unplug the AC power cord and set the front panel controls as follows:

- TONE control to center position.
- BALANCE control to center position.
- POWER switch to OFF
- SPEAKERS switch to OFF
- FUNCTION switch to AUX/VIDEO
- LOUDNESS switch to OFF
- VOLUME control to MINIMUM position
- LEFT CHANNEL DRIVEN

ONE CHANNEL DRIVEN:

- 1) Connect a low distortion audio generator to LEFT AUX IN jack. Set generator frequency to 1 kHz and output to minimum.
- 2) Connect an 8-ohm load resistor between SPEAKERS SYSTEM-A LEFT and COM terminals. Connect a Harmonic Distortion Analyzer and an AC VTVM in parallel across the 8-ohm load.
- 3) Connect the AC power cord and set SPEAKERS switch to ON position. Turn VOLUME control to MAX.
- 4) Increase generator output for 100 Watts RMS (28.2 volts across the 8-ohm load). Harmonic Distortion Analyzer should measure 0.05 % distortion or less.
- 5) Repeat steps 1 through 4 for RIGHT CHANNEL.

BOTH CHANNELS DRIVEN

Connect 8-ohm load resistors across LEFT and RIGHT SPEAKERS SYSTEM-A terminals. Adjust generator output and "VOLUME" control for 100 watts at Left and Right Channels (28.2 volts across the 8-ohm loads). Harmonic Distortion Analyzer should measure 0.05 % distortion or less at each channel.

CAUTION: This precision high-fidelity instrument should be serviced only by qualified personnel, trained in the repair of transistor equipment and printed circuitry.

POWER AMPLIFIER ADJUSTMENT

BEFORE ADJUSTMENT

Unplug the AC power cord and set the front panel controls as follows:

- Power switch to the OFF position.
- Set the SPEAKERS switch to the OFF position.
- Turn the MASTER VOLUME control to the position marked 0 (minimum).
- IDLING CURRENT ADJUSTMENT VR101/VR201 (on the Main P.C.Board) setting to mechanical center position.
- Connect the AC power cord and Power switch to the ON position.

IDLING CURRENT ADJUSTMENT

This adjustment is very sensitive to changes in ambient temperature. Allow set to operate for 5 minutes before attempting this adjustment.

LEFT AMPLIFIER

- 1) Connect the DC VTVM between Pins No.21 and No.22 on the Main P.C.Board.
- 2) Adjust the VR101 for an indication of 7mV on the DC VTVM.

RIGHT AMPLIFIER

- 1) Connect the DC VTVM between Pins No.23 and No.24 on the Main P.C.Board.
- 2) Adjust the VR201 for an indication of 7mV on the DC VTVM.

INTEGRATED CIRCUIT BLOCK DIAGRAM

FUNCTION ANALOG SWITCH IC LC 7815 H

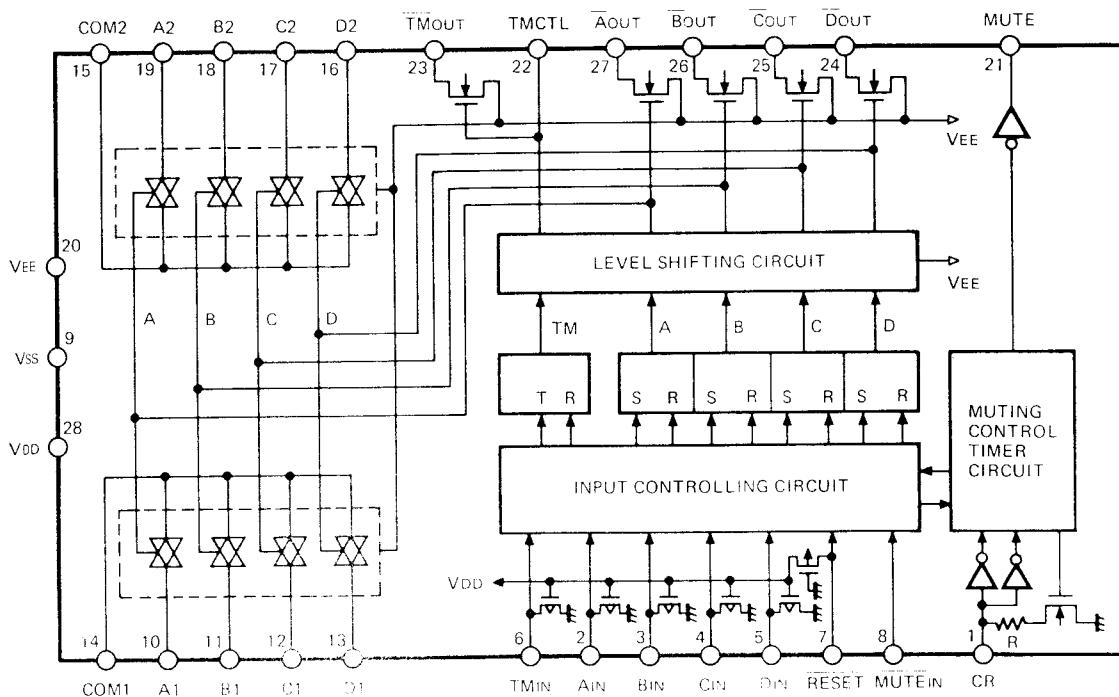

INTEGRATED CIRCUIT BLOCK DIAGRAM (Continued)

TAPE INPUT ANALOG SWITCH IC LC 4066 B

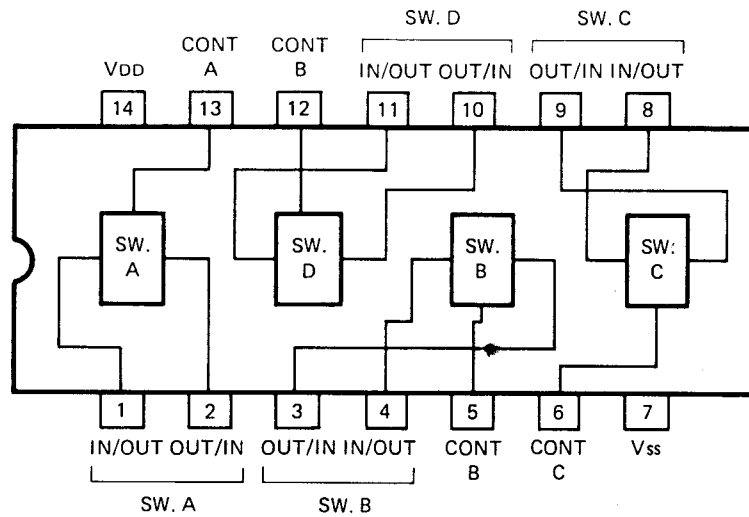

PHONO / TONE CONTROL AMP IC LA 6458 S

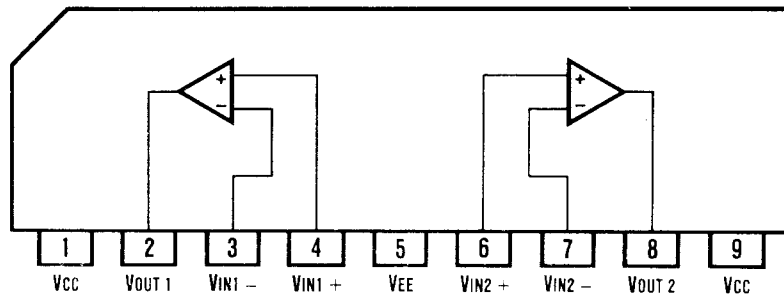

LED METER DRIVE AMP IC IR 2E19

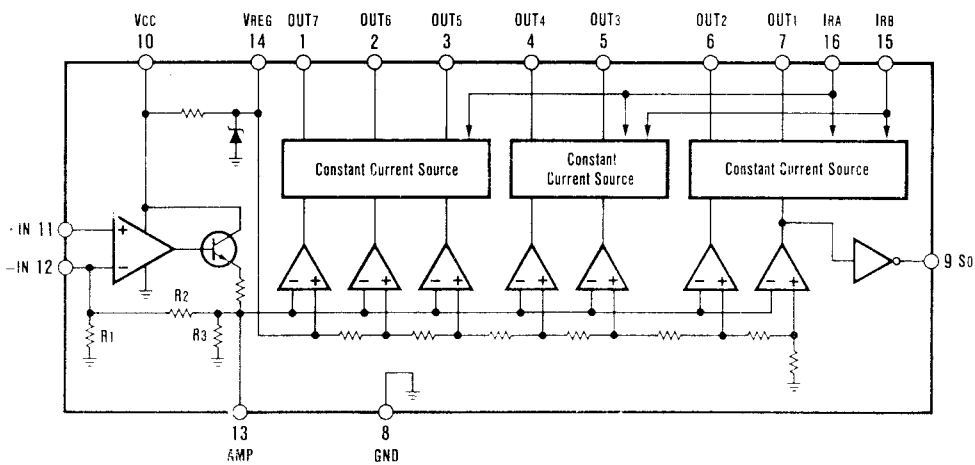

P.C. BOARD PARTS LIST (Continued)

Ref. No.	Part No.	Description	Q'ty	Ref. No.	Part No.	Description	Q'ty
C325	CD1-0-6250-0001V	Electrolytic	10 μ F	25V	1		
C326	CD2-2-5500-0001V	Electrolytic	2.2 μ F	50V	1		
C401	CD1-0-8160-0001V	Electrolytic	1000 μ F	16V	1		
C402	CD1-0-4500-0001V	Electrolytic	0.1 μ F	50V	1		
C409	CC4-7-3500-ZG00C	Ceramic	0.047 μ F	50V +80,-20%	1		
SEMICONDUCTORS							
D401	202-5-3160-00110	Diode, GMA 01			1		
D402	202-5-3160-00110	Diode, GMA 01			1		
D403	202-5-3160-00110	Diode, GMA 01			1		
D404	202-5-3160-00110	Diode, GMA 01			1		
IC401	4-2069-74450	IC, M 5218 L-R			1		
IC402	206-5-8897-81520	IC, LC 7815 H			1		
IC403	206-5-8144-06610	IC, LC 4066 BH			1		
RESISTORS							
R101	RD1-0-2161-JH000	Carbon	1k Ω	1/6W \pm 5%	1		
R102	RD1-0-4161-JH000	Carbon	100k Ω	1/6W \pm 5%	1		
R103	RD1-0-4161-JH000	Carbon	100k Ω	1/6W \pm 5%	1		
R104	RD3-3-1161-JH000	Carbon	330 Ω	1/6W \pm 5%	1		
R105	RD2-2-4161-JH000	Carbon	220k Ω	1/6W \pm 5%	1		
R106	RD1-5-3161-JH000	Carbon	15k Ω	1/6W \pm 5%	1		
R107	RD1-0-4161-JH000	Carbon	100k Ω	1/6W \pm 5%	1		
R108	RD1-0-2161-JH000	Carbon	1k Ω	1/6W \pm 5%	1		
R109	RD1-0-2161-JH000	Carbon	1k Ω	1/6W \pm 5%	1		
R110	RD1-8-4161-JH000	Carbon	180k Ω	1/6W \pm 5%	1		
R111	RD1-0-2161-JH000	Carbon	1k Ω	1/6W \pm 5%	1		
R112	RD1-8-4161-JH000	Carbon	180k Ω	1/6W \pm 5%	1		
R113	RD1-0-2161-JH000	Carbon	1k Ω	1/6W \pm 5%	1		
R114	RD1-8-4161-JH000	Carbon	180k Ω	1/6W \pm 5%	1		
R115	RD1-0-2161-JH000	Carbon	1k Ω	1/6W \pm 5%	1		
R116	RD1-8-4161-JH000	Carbon	180k Ω	1/6W \pm 5%	1		
R117	RD1-0-2161-JH000	Carbon	1k Ω	1/6W \pm 5%	1		
R118	RD8-2-3161-JH000	Carbon	82k Ω	1/6W \pm 5%	1		
R201	RD1-0-2161-JH000	Carbon	1k Ω	1/6W \pm 5%	1		
R202	RD1-0-4161-JH000	Carbon	100k Ω	1/6W \pm 5%	1		
R203	RD1-0-4161-JH000	Carbon	100k Ω	1/6W \pm 5%	1		
R204	RD3-3-1161-JH000	Carbon	330 Ω	1/6W \pm 5%	1		
R205	RD2-2-4161-JH000	Carbon	220k Ω	1/6W \pm 5%	1		
R206	RD1-5-3161-JH000	Carbon	15k Ω	1/6W \pm 5%	1		
R207	RD1-0-4161-JH000	Carbon	100k Ω	1/6W \pm 5%	1		
R208	RD1-0-2161-JH000	Carbon	1k Ω	1/6W \pm 5%	1		
R209	RD1-0-2161-JH000	Carbon	1k Ω	1/6W \pm 5%	1		
R210	RD1-8-4161-JH000	Carbon	180k Ω	1/6W \pm 5%	1		
R211	RD1-0-2161-JH000	Carbon	1k Ω	1/6W \pm 5%	1		
R212	RD1-8-4161-JH000	Carbon	180k Ω	1/6W \pm 5%	1		
R213	RD1-0-2161-JH000	Carbon	1k Ω	1/6W \pm 5%	1		
R214	RD1-8-4161-JH000	Carbon	180k Ω	1/6W \pm 5%	1		
R215	RD1-0-2161-JH000	Carbon	1k Ω	1/6W \pm 5%	1		
R216	RD1-8-4161-JH000	Carbon	180k Ω	1/6W \pm 5%	1		
R217	RD1-0-2161-JH000	Carbon	1k Ω	1/6W \pm 5%	1		
R218	RD8-2-3161-JH000	Carbon	82k Ω	1/6W \pm 5%	1		
R315	RD1-0-2251-JM000	Carbon	1k Ω	1/4W \pm 5%	1		
R316	RD1-0-2251-JM000	Carbon	1k Ω	1/4W \pm 5%	1		
R317	RD2-2-1251-JM000	Carbon	220 Ω	1/4W \pm 5%	1		
R318	RD2-7-1251-JM000	Carbon	270 Ω	1/4W \pm 5%	1		
R319	RD2-7-2161-JH000	Carbon	2.7k Ω	1/6W \pm 5%	1		
R320	RD2-2-4161-JH000	Carbon	220k Ω	1/6W \pm 5%	1		
R321	RD1-0-3161-JH000	Carbon	10k Ω	1/6W \pm 5%	1		
R401	RD4-7-2251-JM000	Carbon	4.7k Ω	1/4W \pm 5%	1		
R402	RD1-0-3161-JH000	Carbon	10k Ω	1/6W \pm 5%	1		
R403	RD1-0-2161-JH000	Carbon	1k Ω	1/6W \pm 5%	1		
R404	RD5-6-3161-JH000	Carbon	56k Ω	1/6W \pm 5%	1		
				FUNCTION P.C.B. ASSY			
PCB3	141-0-1939-09140	Function P.C.B. Assy					
	4-2262-22050	Function P.C.B.					
	141-2-2419-33000	Reflector					
SW401	4-2312-05300	Keyboard Switch 6mm (Phono)					
SW402	4-2312-05300	Keyboard Switch 6mm (Tuner)					
SW403	4-2312-05300	Keyboard Switch 6mm (Compact Disc)					
SW404	4-2312-05300	Keyboard Switch 6mm (AUX/Video)					
SW405	4-2312-05300	Keyboard Switch 6mm (Tape Monitor)					
B	4-2359-77807	Connector 5P Assy					
C	4-2359-77808	Connector 6P Assy					
				CAPACITORS			
C403	CI1-0-3250-MF00R	Boundary	0.01 μ F	25V \pm 20%			
C404	CI1-0-3250-MF00R	Boundary	0.01 μ F	25V \pm 20%			
C405	CI1-0-3250-MF00R	Boundary	0.01 μ F	25V \pm 20%			
C406	CI1-0-3250-MF00R	Boundary	0.01 μ F	25V \pm 20%			
C407	CI1-0-3250-MF00R	Boundary	0.01 μ F	25V \pm 20%			
				SEMICONDUCTORS			
D311	202-5-3210-10011	Zener Diode, GZA 10 X					
D312	202-5-3210-10011	Zener Diode, GZA 10 X					
D405	4-2029-73860	L.E.D., SEL 1413 E (Phono)					
D406	4-2029-73860	L.E.D., SEL 1413 E (Tuner)					
D407	4-2029-73860	L.E.D., SEL 1413 E (Compact Disc)					
D408	4-2029-73860	L.E.D., SEL 1413 E (AUX/Video)					
D409	4-2029-73850	L.E.D., SEL 1213 C (Tape Monitor)					
				RESISTORS			
R322	RD5-6-1251-JM000	Carbon	560 Ω	1/4W \pm 5%			
R323	RD1-2-2251-JM000	Carbon	1.2k Ω	1/4W \pm 5%			
R324	RD1-0-3251-JM000	Carbon	10k Ω	1/4W \pm 5%			
				TONE CONTROL P.C.B. ASSY			
PCB4	141-0-1939-09151	Tone Control P.C.B. Assy					
	4-2262-22060	Tone Control P.C.B.					
SW406	4-2319-77780	Switch Push 1 Key (Meter Range)					
SW407	4-2319-77780	Switch Push 1 Key (Loudness)					
VR402	4-2229-75600	Slide Volume (W-250k Ω x2, Bass)					
VR403	4-2229-75600	Slide Volume (W-250k Ω x2, Treble)					
VR406	4-2229-75590	Slide Volume (W-200k Ω , Balance)					
VR407	4-2229-75610	Slide Volume (A-100k Ω x2, Volume)					
	141-2-2419-33100	Mount LED					
	141-2-3769-17800	Spacer LED					
A	4-2359-77809	Connector 6P Assy					
D	131-0-4006-31418	Cord Assy					
E	131-0-4006-31423	Cord Assy					
	4-2379-21120	Terminal					
				CAPACITORS			
C121	CD4-7-5250-0001V	Electrolytic	4.7 μ F	25V			
C122	CC1-0-1500-KE01R	Ceramic	100pF	50V			
C123	CC6-8-0500-KD00C	Ceramic	68pF	50V			
C124	CC1-0-0500-DD00C	Ceramic	10pF	50V			
C125	CD1-0-6160-0002V	Electrolytic	10 μ F	16V			
C126	CD4-7-5250-0002V	Electrolytic	4.7 μ F	25V			
C127	CC2-2-1500-KE01R	Ceramic	220pF	50V			
C129	CD1-0-6160-0002V	Electrolytic	10 μ F	16V			
C130	CM1-0-3500-J00TV	Mylar	0.01 μ F	50V			
C134	CM2-2-3500-J00BV	Mylar	0.022 μ F	50V			
C135	CC2-7-1500-KD00C	Ceramic	270pF	50V			
C138	CC2-2-1500-KE01R	Ceramic	220pF	50V			
C139	CM4-7-3500-J00TV	Mylar	0.047 μ F	50V			

P.C. BOARD PARTS LIST (Continued)

Ref. No.	Part No.	Description	Q'ty	Ref. No.	Part No.	Description	Q'ty
C325	CD1-0-6250-0001V	Electrolytic	10 μ F	25V	1		
C326	CD2-2-5500-0001V	Electrolytic	2.2 μ F	50V	1		
C401	CD1-0-8160-0001V	Electrolytic	1000 μ F	16V	1		
C402	CD1-0-4500-0001V	Electrolytic	0.1 μ F	50V	1		
C409	CC4-7-3500-ZG00C	Ceramic	0.047 μ F	50V +80,-20%	1		
SEMICONDUCTORS							
D401	202-5-3160-00110	Diode, GMA 01			1		
D402	202-5-3160-00110	Diode, GMA 01			1		
D403	202-5-3160-00110	Diode, GMA 01			1		
D404	202-5-3160-00110	Diode, GMA 01			1		
IC401	4-2069-74450	IC, M 5218 L-R			1		
IC402	206-5-8897-81520	IC, LC 7815 H			1		
IC403	206-5-8144-06610	IC, LC 4066 BH			1		
RESISTORS							
R101	RD1-0-2161-JH000	Carbon	1k Ω	1/6W \pm 5%	1		
R102	RD1-0-4161-JH000	Carbon	100k Ω	1/6W \pm 5%	1		
R103	RD1-0-4161-JH000	Carbon	100k Ω	1/6W \pm 5%	1		
R104	RD3-3-1161-JH000	Carbon	330 Ω	1/6W \pm 5%	1		
R105	RD2-2-4161-JH000	Carbon	220k Ω	1/6W \pm 5%	1		
R106	RD1-5-3161-JH000	Carbon	15k Ω	1/6W \pm 5%	1		
R107	RD1-0-4161-JH000	Carbon	100k Ω	1/6W \pm 5%	1		
R108	RD1-0-2161-JH000	Carbon	1k Ω	1/6W \pm 5%	1		
R109	RD1-0-2161-JH000	Carbon	1k Ω	1/6W \pm 5%	1		
R110	RD1-8-4161-JH000	Carbon	180k Ω	1/6W \pm 5%	1		
R111	RD1-0-2161-JH000	Carbon	1k Ω	1/6W \pm 5%	1		
R112	RD1-8-4161-JH000	Carbon	180k Ω	1/6W \pm 5%	1		
R113	RD1-0-2161-JH000	Carbon	1k Ω	1/6W \pm 5%	1		
R114	RD1-8-4161-JH000	Carbon	180k Ω	1/6W \pm 5%	1		
R115	RD1-0-2161-JH000	Carbon	1k Ω	1/6W \pm 5%	1		
R116	RD1-8-4161-JH000	Carbon	180k Ω	1/6W \pm 5%	1		
R117	RD1-0-2161-JH000	Carbon	1k Ω	1/6W \pm 5%	1		
R118	RD8-2-3161-JH000	Carbon	82k Ω	1/6W \pm 5%	1		
R201	RD1-0-2161-JH000	Carbon	1k Ω	1/6W \pm 5%	1		
R202	RD1-0-4161-JH000	Carbon	100k Ω	1/6W \pm 5%	1		
R203	RD1-0-4161-JH000	Carbon	100k Ω	1/6W \pm 5%	1		
R204	RD3-3-1161-JH000	Carbon	330 Ω	1/6W \pm 5%	1		
R205	RD2-2-4161-JH000	Carbon	220k Ω	1/6W \pm 5%	1		
R206	RD1-5-3161-JH000	Carbon	15k Ω	1/6W \pm 5%	1		
R207	RD1-0-4161-JH000	Carbon	100k Ω	1/6W \pm 5%	1		
R208	RD1-0-2161-JH000	Carbon	1k Ω	1/6W \pm 5%	1		
R209	RD1-0-2161-JH000	Carbon	1k Ω	1/6W \pm 5%	1		
R210	RD1-8-4161-JH000	Carbon	180k Ω	1/6W \pm 5%	1		
R211	RD1-0-2161-JH000	Carbon	1k Ω	1/6W \pm 5%	1		
R212	RD1-8-4161-JH000	Carbon	180k Ω	1/6W \pm 5%	1		
R213	RD1-0-2161-JH000	Carbon	1k Ω	1/6W \pm 5%	1		
R214	RD1-8-4161-JH000	Carbon	180k Ω	1/6W \pm 5%	1		
R215	RD1-0-2161-JH000	Carbon	1k Ω	1/6W \pm 5%	1		
R216	RD1-8-4161-JH000	Carbon	180k Ω	1/6W \pm 5%	1		
R217	RD1-0-2161-JH000	Carbon	1k Ω	1/6W \pm 5%	1		
R218	RD8-2-3161-JH000	Carbon	82k Ω	1/6W \pm 5%	1		
R315	RD1-0-2251-JM000	Carbon	1k Ω	1/4W \pm 5%	1		
R316	RD1-0-2251-JM000	Carbon	1k Ω	1/4W \pm 5%	1		
R317	RD2-2-1251-JM000	Carbon	220 Ω	1/4W \pm 5%	1		
R318	RD2-7-1251-JM000	Carbon	270 Ω	1/4W \pm 5%	1		
R319	RD2-7-2161-JH000	Carbon	2.7k Ω	1/6W \pm 5%	1		
R320	RD2-2-4161-JH000	Carbon	220k Ω	1/6W \pm 5%	1		
R321	RD1-0-3161-JH000	Carbon	10k Ω	1/6W \pm 5%	1		
R401	RD4-7-2251-JM000	Carbon	4.7k Ω	1/4W \pm 5%	1		
R402	RD1-0-3161-JH000	Carbon	10k Ω	1/6W \pm 5%	1		
R403	RD1-0-2161-JH000	Carbon	1k Ω	1/6W \pm 5%	1		
R404	RD5-6-3161-JH000	Carbon	56k Ω	1/6W \pm 5%	1		
FUNCTION P.C.B. ASSY							
PCB3	141-0-1939-09140	Function P.C.B. Assy			1		
	4-2262-22050	Function P.C.B.			1		
	141-2-2419-33000	Reflector			1		
SW401	4-2312-05300	Keyboard Switch 6mm (Phono)			1		
SW402	4-2312-05300	Keyboard Switch 6mm (Tuner)			1		
SW403	4-2312-05300	Keyboard Switch 6mm (Compact Disc)			1		
SW404	4-2312-05300	Keyboard Switch 6mm (AUX/Video)			1		
SW405	4-2312-05300	Keyboard Switch 6mm (Tape Monitor)			1		
B	4-2359-77807	Connector 5P Assy			1		
C	4-2359-77808	Connector 6P Assy			1		
CAPACITORS							
C403	CH-0-3250-MF00R	Boundary	0.01 μ F	25V \pm 20%	1		
C404	CH-0-3250-MF00R	Boundary	0.01 μ F	25V \pm 20%	1		
C405	CH-0-3250-MF00R	Boundary	0.01 μ F	25V \pm 20%	1		
C406	CH-0-3250-MF00R	Boundary	0.01 μ F	25V \pm 20%	1		
C407	CH-0-3250-MF00R	Boundary	0.01 μ F	25V \pm 20%	1		
SEMICONDUCTORS							
D311	202-5-3210-10011	Zener Diode, GZA 10 X			1		
D312	202-5-3210-10011	Zener Diode, GZA 10 X			1		
D405	4-2029-73860	L.E.D., SEL 1413 E (Phono)			1		
D406	4-2029-73860	L.E.D., SEL 1413 E (Tuner)			1		
D407	4-2029-73860	L.E.D., SEL 1413 E (Compact Disc)			1		
D408	4-2029-73860	L.E.D., SEL 1413 E (AUX/Video)			1		
D409	4-2029-73850	L.E.D., SEL 1213 C (Tape Monitor)			1		
RESISTORS							
R322	RD5-6-1251-JM000	Carbon	560 Ω	1/4W \pm 5%	1		
R323	RD1-2-2251-JM000	Carbon	1.2k Ω	1/4W \pm 5%	1		
R324	RD1-0-3251-JM000	Carbon	10k Ω	1/4W \pm 5%	1		
TONE CONTROL P.C.B. ASSY							
PCB4	141-0-1939-09151	Tone Control P.C.B. Assy			1		
	4-2262-22060	Tone Control P.C.B.			1		
SW406	4-2319-77780	Switch Push 1 Key (Meter Range)			1		
SW407	4-2319-77780	Switch Push 1 Key (Loudness)			1		
VR402	4-2229-75600	Slide Volume (W-250k Ω x2, Bass)			1		
VR403	4-2229-75600	Slide Volume (W-250k Ω x2, Treble)			1		
VR406	4-2229-75590	Slide Volume (W-200k Ω , Balance)			1		
VR407	4-2229-75610	Slide Volume (A-100k Ω x2, Volume)			1		
	141-2-2419-33100	Mount LED			1		
	141-2-3769-17800	Spacer LED			1		
A	4-2359-77809	Connector 6P Assy			1		
D	131-0-4006-31418	Cord Assy			1		
E	131-0-4006-31423	Cord Assy			1		
	4-2379-21120	Terminal			1		
CAPACITORS							
C121	CD4-7-5250-0001V	Electrolytic	47 μ F	25V \pm 20%	1		
C122	CC1-0-1500-KE01R	Ceramic	1000pF	50V \pm 10%	1		
C123	CC6-8-0500-KD00C	Ceramic	680pF	50V \pm 10%	1		
C124	CC1-0-0500-DD00C	Ceramic	100pF	50V \pm 10%	1		
C125	CD1-0-6160-0002V	Electrolytic	10 μ F	25V \pm 20%	1		
C126	CD4-7-5250-0002V	Electrolytic	47 μ F	25V \pm 20%	1		
C127	CC2-2-1500-KE01R	Ceramic	2200pF	50V \pm 10%	1		
C129	CD1-0-6160-0002V	Electrolytic	10 μ F	25V \pm 20%	1		
C130	CM1-0-3500-J00TV	Mylar	0.01 μ F	50V \pm 10%	1		
C134	CM2-2-3500-J00BV	Mylar	0.022 μ F	50V \pm 10%	1		
C135	CC2-7-1500-KD00C	Ceramic	1500pF	50V \pm 10%	1		
C138	CC2-2-1500-KE01R	Ceramic	2200pF	50V \pm 10%	1		
C139	CM4-7-3500-J00TV	Mylar	0.047 μ F	50V \pm 10%	1		

P.C. BOARD PARTS LIST (Continued)

Ref. No.	Part No.	Description	Q'ty	Ref. No.	Part No.	Description	Q'ty	
C159	CD1-0-6250-0001V	Electrolytic	10μF 25V	1	R172	RD1-5-2161-JH000	Carbon 1.5kΩ 1/6W ±5%	1
C160	CC1-0-2500-KE01R	Ceramic	0.001μF 50V ±10%	1	R173	RD3-9-2161-JH000	Carbon 3.9kΩ 1/6W ±5%	1
C161	CD1-0-6250-0001V	Electrolytic	10μF 25V	1	R174	RD3-3-2161-JH000	Carbon 3.3kΩ 1/6W ±5%	1
C162	CD1-0-6250-0001V	Electrolytic	10μF 25V	1	R219	RD1-5-4161-JH000	Carbon 150kΩ 1/6W ±5%	1
C221	CD4-7-5250-0001V	Electrolytic	4.7μF 25V	1	R220	RD2-7-2161-JH000	Carbon 2.7kΩ 1/6W ±5%	1
C222	CC1-0-1500-KE01R	Ceramic	100pF 50V ±10%	1	R221	RD4-7-2161-JH000	Carbon 4.7kΩ 1/6W ±5%	1
C223	CC6-8-0500-KD00C	Ceramic	68pF 50V ±10%	1	R222	RD3-3-2161-JH000	Carbon 3.3kΩ 1/6W ±5%	1
C224	CC1-0-0500-DD00C	Ceramic	10pF 50V ±0.5%	1	R223	RD4-7-2161-JH000	Carbon 4.7kΩ 1/6W ±5%	1
C225	CD1-0-6160-0002V	Electrolytic	10μF 16V	1	R224	RD2-2-2161-JH000	Carbon 2.2kΩ 1/6W ±5%	1
C226	CD4-7-5250-0002V	Electrolytic	4.7μF 25V	1	R226	RD8-2-1161-JH000	Carbon 820Ω 1/6W ±5%	1
C227	CC2-2-1500-KE01R	Ceramic	220pF 50V ±10%	1	R227	RD8-2-1161-JH000	Carbon 820Ω 1/6W ±5%	1
C229	CD1-0-6160-0002V	Electrolytic	10μF 16V	1	R231	RD1-5-4161-JH000	Carbon 150kΩ 1/6W ±5%	1
C230	CM1-0-3500-J00TV	Mylar	0.01μF 50V ±5%	1	R232	RD2-2-3161-JH000	Carbon 22kΩ 1/6W ±5%	1
C234	CM2-2-3500-J00BV	Mylar	0.022μF 50V ±5%	1	R236	RD3-9-1161-JH000	Carbon 390Ω 1/6W ±5%	1
C235	CC2-7-1500-KD00C	Ceramic	270pF 50V ±10%	1	R237	RD3-9-1161-JH000	Carbon 390Ω 1/6W ±5%	1
C238	CC2-2-1500-KE01R	Ceramic	220pF 50V ±10%	1	R241	RD5-6-2161-JH000	Carbon 5.6kΩ 1/6W ±5%	1
C239	CM4-7-3500-J00TV	Mylar	0.047μF 50V ±5%	1	R242	RD5-6-2161-JH000	Carbon 5.6kΩ 1/6W ±5%	1
C259	CD1-0-6250-0001V	Electrolytic	10μF 25V	1	R245	RD5-6-2161-JH000	Carbon 5.6kΩ 1/6W ±5%	1
C260	CC1-0-2500-KE01R	Ceramic	0.001μF 50V ±10%	1	R272	RD1-5-2161-JH000	Carbon 1.5kΩ 1/6W ±5%	1
C261	CD1-0-6250-0001V	Electrolytic	10μF 25V	1	R273	RD3-9-2161-JH000	Carbon 3.9kΩ 1/6W ±5%	1
C262	CD1-0-6250-0001V	Electrolytic	10μF 25V	1	R274	RD3-3-2161-JH000	Carbon 3.3kΩ 1/6W ±5%	1
C319	CD1-0-7250-0006V	Electrolytic	100μF 25V	1	R313	RD5-6-A161-JH000	Carbon 5.6Ω 1/6W ±5%	1
C320	CD1-0-7250-0006V	Electrolytic	100μF 25V	1	R314	RD5-6-A161-JH000	Carbon 5.6Ω 1/6W ±5%	1
C327	CD1-0-6250-0001V	Electrolytic	10μF 25V	1				
SEMICONDUCTORS					SPEAKER TERMINAL P.C.B. ASSY			
D104	D00---SLP--273B-	L.E.D., SLP 273 B (Power Level Meter)	1	PCB5	141-0-1939-09172	Speaker Terminal P.C.B. Assy	1	
D105	D00---SLP--273B-	L.E.D., SLP 273 B (Power Level Meter)	1		4-2262-22080	Speaker Terminal P.C.B.	1	
D106	D00---SLP--273B-	L.E.D., SLP 273 B (Power Level Meter)	1		4-2372-01160	Speaker 8P Terminal (Speaker)	1	
D107	D00---SLP--273B-	L.E.D., SLP 273 B (Power Level Meter)	1		111-2-6220-11100	Wire Wrap Terminal	6	
D108	D00---SLP--273B-	L.E.D., SLP 273 B (Power Level Meter)	1					
D109	D00---SLP--273B-	L.E.D., SLP 273 B (Power Level Meter)	1					
D110	D00---SLP--273B-	L.E.D., SLP 273 B (Power Level Meter)	1					
D204	D00---SLP--273B-	L.E.D., SLP 273 B (Power Level Meter)	1	C507	CC4-7-1500-KE00C	Ceramic 470pF 50V ±10%	1	
D205	D00---SLP--273B-	L.E.D., SLP 273 B (Power Level Meter)	1	C508	CC4-7-1500-KE00C	Ceramic 470pF 50V ±10%	1	
D206	D00---SLP--273B-	L.E.D., SLP 273 B (Power Level Meter)	1	C509	CC4-7-1500-KE00C	Ceramic 470pF 50V ±10%	1	
D207	D00---SLP--273B-	L.E.D., SLP 273 B (Power Level Meter)	1	C510	CC4-7-1500-KE00C	Ceramic 470pF 50V ±10%	1	
D208	D00---SLP--273B-	L.E.D., SLP 273 B (Power Level Meter)	1					
D209	D00---SLP--273B-	L.E.D., SLP 273 B (Power Level Meter)	1					
D210	D00---SLP--273B-	L.E.D., SLP 273 B (Power Level Meter)	1					
IC101	4-2069-73670	IC, IR 2 E 19	1					
IC201	4-2069-73670	IC, IR 2 E 19	1					
IC404	206-5-3266-45810	IC, LA 6458 SS	1					
Q102	203-5-5000-53660	Transistor, 2SC 536	1	D412	205-5-9040-44210	Diode, DS 442	1	
Q103	203-5-5000-53660	Transistor, 2SC 536	1	Q403	4-2039-72100	Transistor, 2SD 947	1	
Q202	203-5-5000-53660	Transistor, 2SC 536	1					
Q203	203-5-5000-53660	Transistor, 2SC 536	1					
RESISTORS					SEMICONDUCTORS			
R119	RD1-5-4161-JH000	Carbon	150kΩ 1/6W ±5%	1				
R120	RD2-7-2161-JH000	Carbon	2.7kΩ 1/6W ±5%	1				
R121	RD4-7-2161-JH000	Carbon	4.7kΩ 1/6W ±5%	1				
R122	RD3-3-2161-JH000	Carbon	3.3kΩ 1/6W ±5%	1				
R123	RD4-7-2161-JH000	Carbon	4.7kΩ 1/6W ±5%	1	S408	△ 4-2319-76340	Switch Push Power (Power)	1
R124	RD2-2-2161-JH000	Carbon	2.2kΩ 1/6W ±5%	1	S409	4-2319-77340	Switch Push 1 Key (Speaker A)	1
R126	RD8-2-1161-JH000	Carbon	820Ω 1/6W ±5%	1	S410	4-2319-77340	Switch Push 1 Key (Speaker B)	1
R127	RD8-2-1161-JH000	Carbon	820Ω 1/6W ±5%	1		4-2352-00970	Headphone Jack 3P (Headphones)	1
R131	RD1-0-5161-JH000	Carbon	150kΩ 1/6W ±5%	1		111-2-6220-11100	Wire Wrap Terminal	1
R132	RD2-2-3161-JH000	Carbon	22kΩ 1/6W ±5%	1		131-2-6114-00200	Cover Safety	1
R136	RD3-9-1161-JH000	Carbon	390Ω 1/6W ±5%	1		4-2372-00830	EC Terminal 1P	2
R137	RD3-9-1161-JH000	Carbon	390Ω 1/6W ±5%	1		4-2439-72192	Wire 6 Parallel	1
R141	RD5-6-2161-JH000	Carbon	5.6kΩ 1/6W ±5%	1		4-2439-72193	Wire 2 Parallel	1
R142	RD5-6-2161-JH000	Carbon	5.6kΩ 1/6W ±5%	1				
R145	RD5-6-2161-JH000	Carbon	5.6kΩ 1/6W ±5%	1				
					PCB7	141-0-1939-09192	Switch P.C.B. Assy	1
						4-2262-22100	Switch P.C.B.	1
						△ 4-2349-20380	Fuse T1.0A	2
						4-2352-00200	Fuse Holder	4
						131-2-7103-40400	Label 1.0AT 4x13	1
						△ 4-2319-76340	Switch Push Power (Power)	1
						4-2319-77340	Switch Push 1 Key (Speaker A)	1
						4-2319-77340	Switch Push 1 Key (Speaker B)	1
						4-2352-00970	Headphone Jack 3P (Headphones)	1
						111-2-6220-11100	Wire Wrap Terminal	1
						131-2-6114-00200	Cover Safety	1
						4-2372-00830	EC Terminal 1P	2
						4-2439-72192	Wire 6 Parallel	1
						4-2439-72193	Wire 2 Parallel	1

Ref. No.	Part No.	Description	Q'ty
CAPACITOR			
C301 Δ	4-2239-70970	Capacitor 0.01 μ F 400V \pm 100,-0%	1
RESISTORS			
R175	RH5-6-1202-JZ000	Metal 560 Ω 2W \pm 5%	1
R176	RD2-2-1251-JM000	Carbon 220 Ω 1/4W \pm 5%	1
R177	RD2-7-1251-JM000	Carbon 270 Ω 1/4W \pm 5%	1
R275	RH5-6-1202-JZ000	Metal 560 Ω 2W \pm 5%	1
R276	RD2-2-1251-JM000	Carbon 220 Ω 1/4W \pm 5%	1
R277	RD2-7-1251-JM000	Carbon 270 Ω 1/4W \pm 5%	1

NOTES:

1. Parts order must contain Model Number, Part Number and Description.
2. Ordering quantity of screws and resistors must be multiple of 10 pcs.

PRODUCT SAFETY NOTICE

Each precaution in this manual should be followed during servicing. Components identified with the IEC symbol Δ in the parts list and the schematic diagram designate components in which safety can be of special significance. When replacing a component identified with Δ , use only the replacement parts designated, or parts with the same ratings of resistance, wattage or voltage that are designated in the parts list in this manual. Leakage-current or resistance measurements must be made to determine that exposed parts are acceptably insulated from the supply circuit before returning the product to the customer.

SWITCH P.C. BOARD (BOTTOM VIEW)

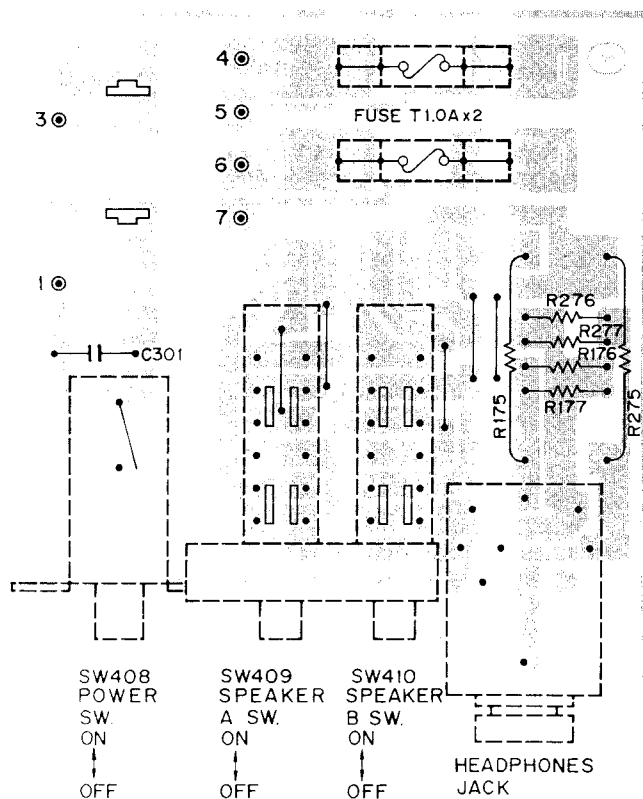

MAIN PRINTED CIRCUIT BOARD (BOTTOM VIEW)

TRANSISTOR P.C.B. ASS'Y
1410-1939-09180

TRANSISTOR P.C.B. ASS'Y
1410-1939-09180

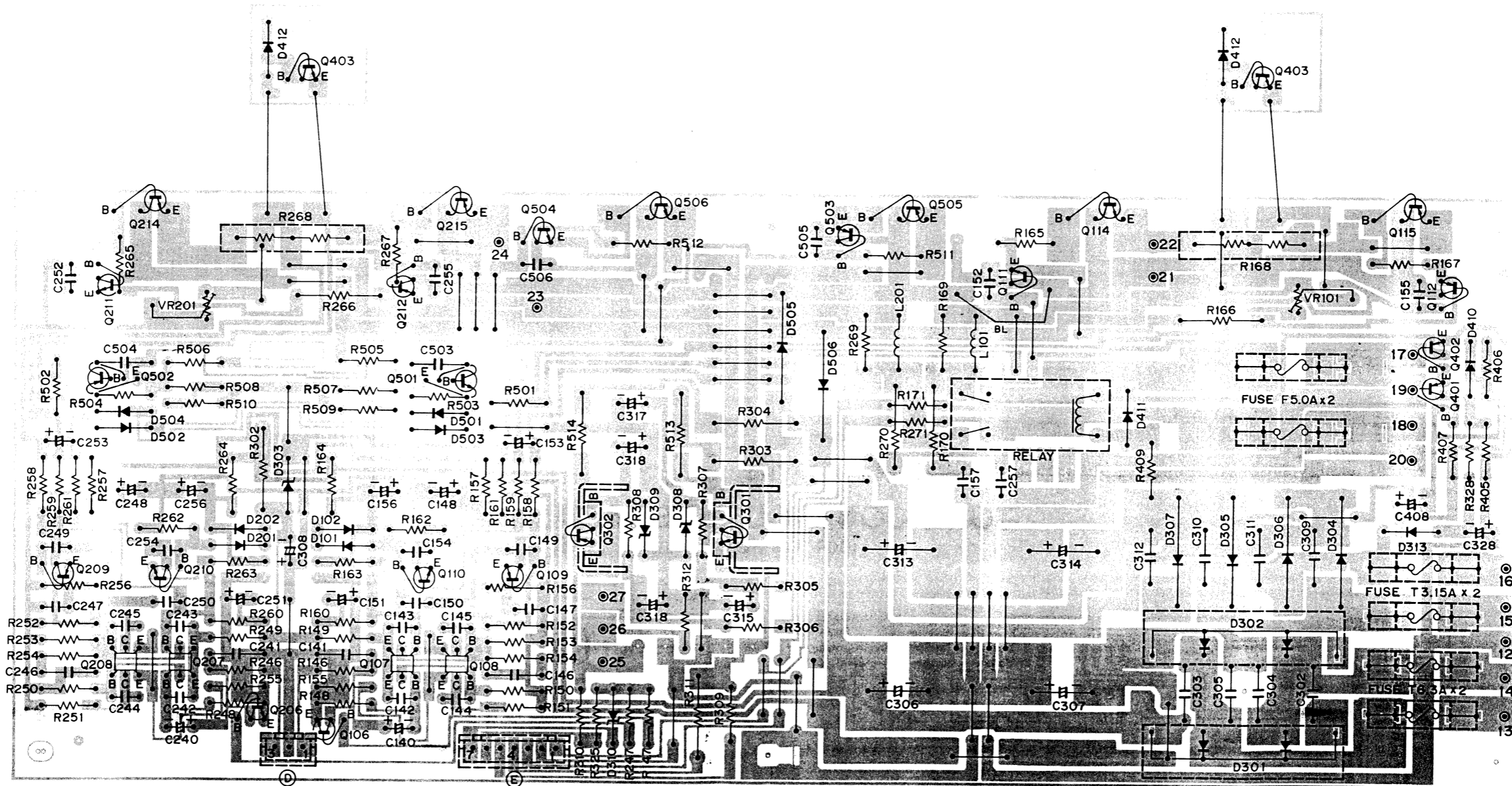

SP TERMINAL P.C. BOARD (BOTTOM VIEW)

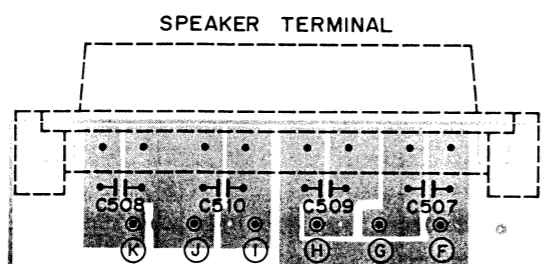

TRANSISTOR DC VOLTAGES

SYMBOL No.	DEVICE	B	C	E	SYMBOL No.	DEVICE	B	C	E
Q106,206	2SD1012	-2.8V	0V	0V	Q302	2SB632	-18.0V	-26.0V	-17.4V
Q107,207	2SC3065	-0.2V	34.0V	-0.8V	Q401	2SA608	-1.4V	-0.8V	-0.8V
Q108,208	2SC3064	34.0V	60.5V	33.3V	Q402	2SA608	-0.8V	0.1V	0V
Q109,209	2SA1209	60.8V	1.5V	61.0V	Q501	2SC2603	24.6V	64.1V	25.9V
Q110,210	2SC2911	-60.5V	-1.5V	-61.0V	Q502	2SA1115	-24.6V	-63.9V	-25.8V
Q111,211	2SC3117	1.1V	61.5V	-1.1V	Q503	2SB631	64.3V	31.8V	64.0V
Q112,212	2SA1249	-0.6V	-61.5V	-1.1V	Q504	2SD600	-64.2V	-31.8V	-63.9V
Q114,214	2SC3281	0.6V	61.5V	0V	Q505	2SA1302	64.0V	31.8V	64.0V
Q115,215	2SA1302	-0.6V	-61.5V	0V	Q506	2SC3281	-63.9V	-31.8V	-64.3V
Q301	2SD612	18.4V	28.2V	17.8V					

INPUT P.C.BOARD (BOTTOM VIEW)

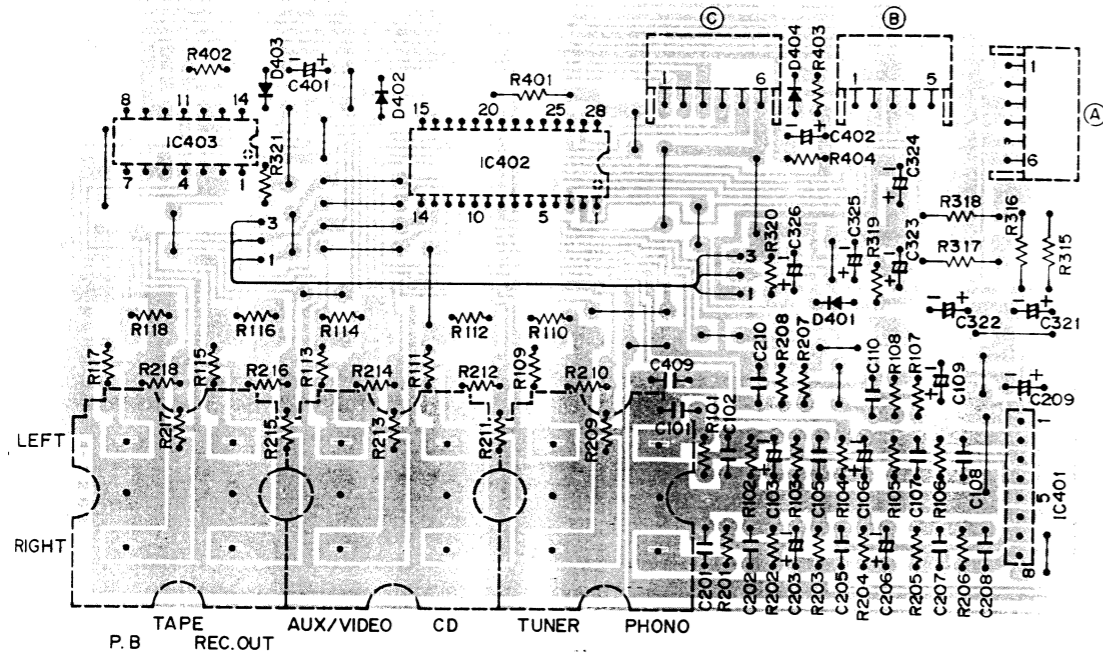

FUNCTION P.C.BOARD (BOTTOM VIEW)

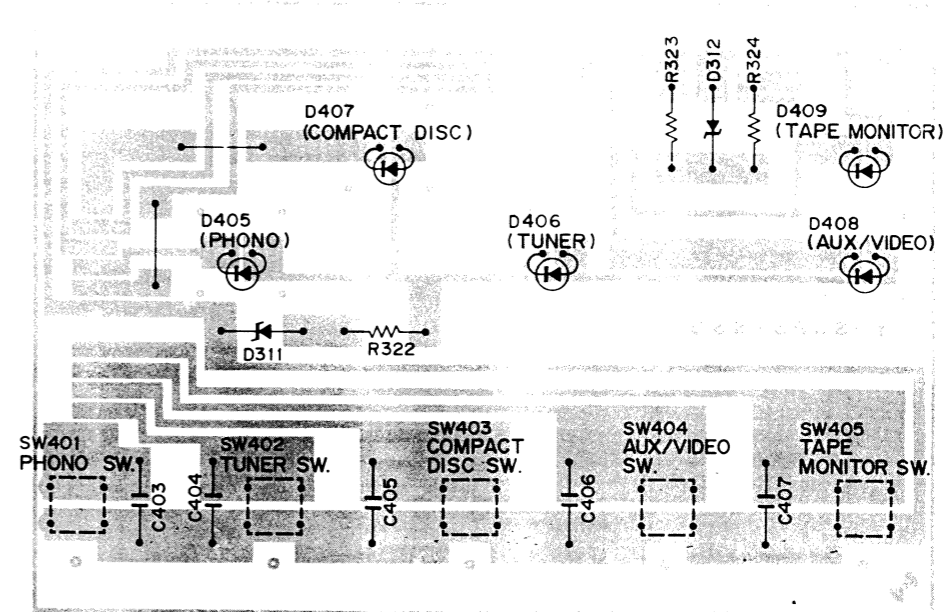

SYMBOL No.		IC PIN NUMBERS DC VOLTAGES													
DEVICE		1	2	3	4	5	6	7	8	9	10	11	12	13	14
IC401	M5218L	11.8V	0V	0V	0V	-11.6V	0V	0V	0V						
IC403	LC4066	0V	0V	0V	0V	-9.1V	-9.1V	-11.0V	0V	0V	0V	0V	11.5V	11.5V	11.5V

TONE CONTROL P.C.BOARD (BOTTOM VIEW)

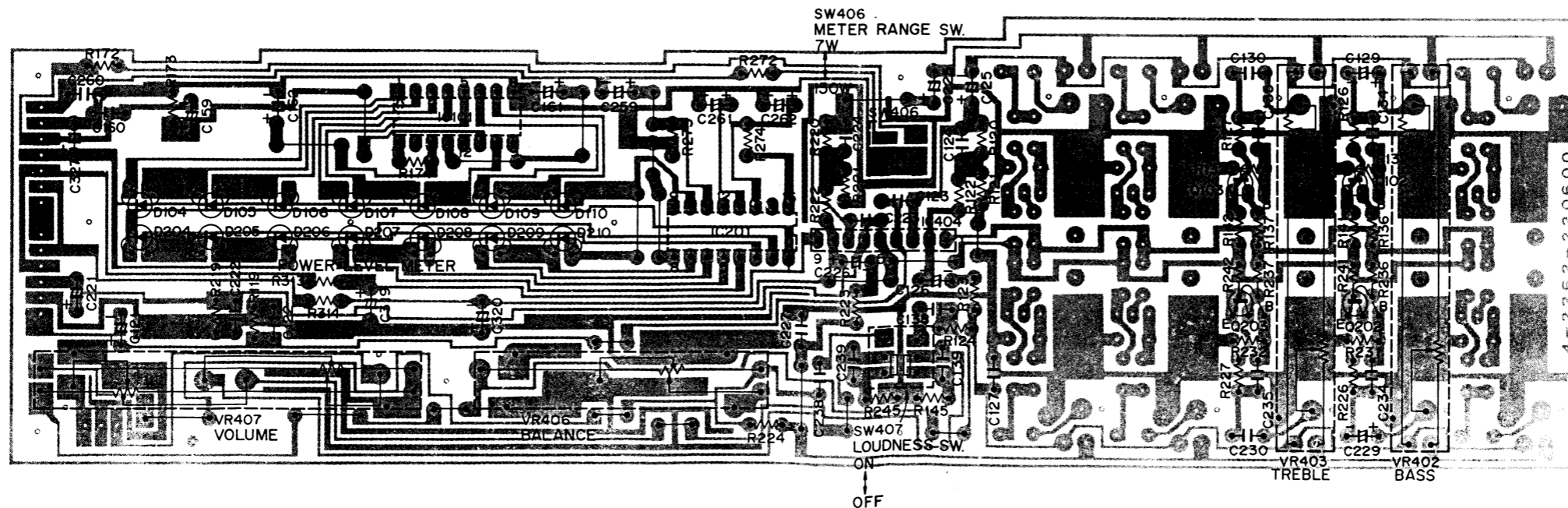

SYMBOL No.		IC PIN NUMBERS DC VOLTAGES															
DEVICE		1	2	3	4	5	6	7	8	9	10	11	12	13	14	15	16
IC101,102	IR2E19	12.4V	13.9V	15.4V	13.9V	15.4V	13.9V	15.4V	0V	0.3V	16.9V	0V	0V	0V	2.7V	0V	0.9V
IC404	LA6458	15.9V	0V	0V	0V	-15.8V	0V	0V	0V	15.9V							

TRANSISTOR DC VOLTAGES				
SYMBOL No.	DEVICE	B	C	E
Q102,202	2SC536	-0.5V	15.1V	-1.1V
Q103,203	2SC536	-0.3V	15.1V	-0.9V

POINT TO POINT WIRING DIAGRAM

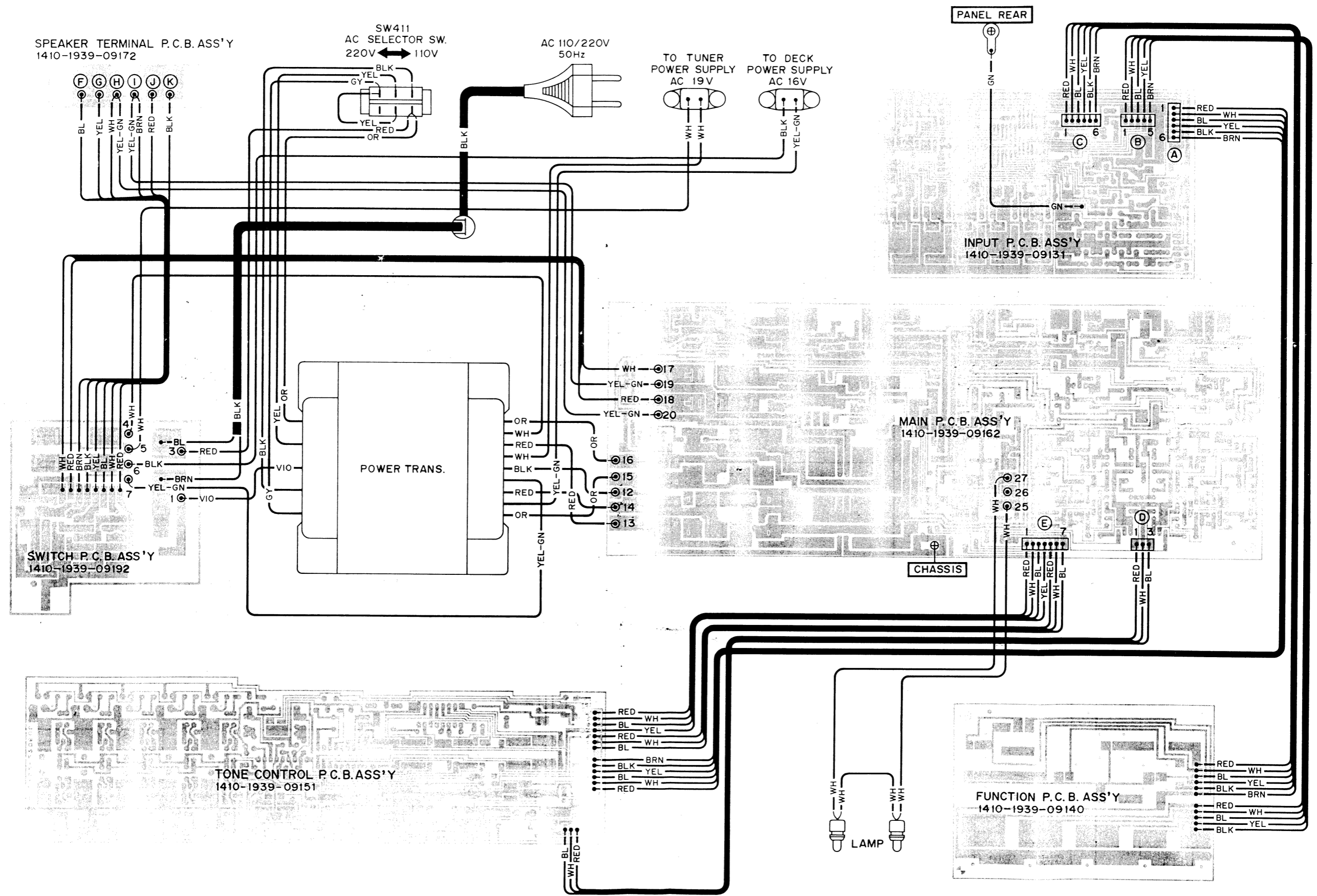

SCHEMATIC DIAGRAM

No.	Name	Position	No.	Name	Position
SW401	PHONO Switch	OFF	SW407	LOUDNESS Switch	OFF
SW402	TUNER Switch	OFF	SW408	POWER Switch	OFF
SW403	COMPACT DISC Switch	OFF	SW409	SPEAKER A Switch	OFF
SW404	AUX/VIDEO Switch	OFF	SW410	SPEAKER B Switch	OFF
SW405	TAPE MONITOR Switch	OFF	SW411	AC SELECTOR Switch	220V
SW406	METER RANGE Switch	150W			220V

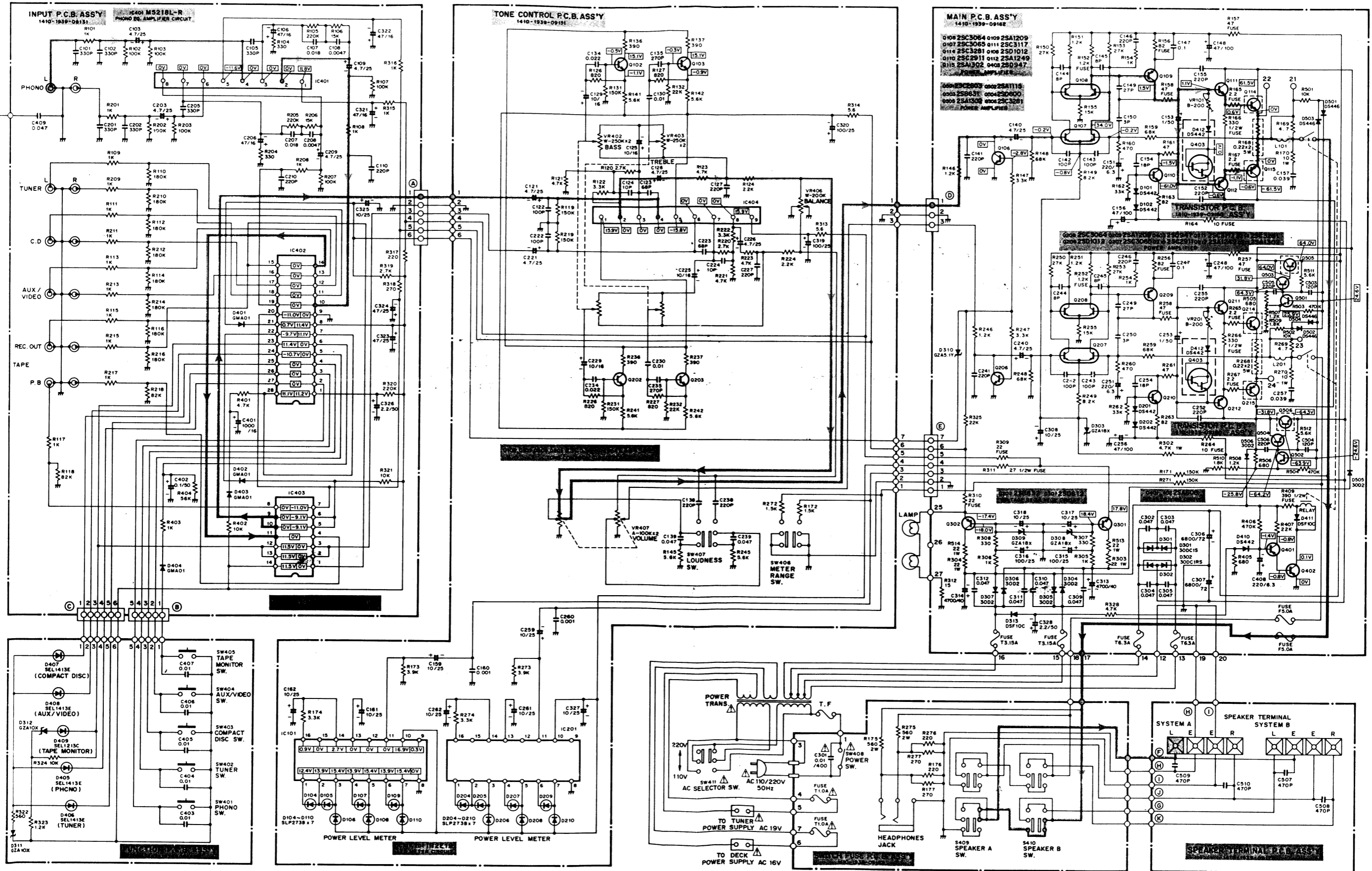

SEMICONDUCTOR LEAD IDENTIFICATION

TRANSISTOR	FRONT VIEW	BOTTOM VIEW
2SC536 2SA608 2SA1115 2SC2603		
2SA1209 2SA1249 2SC2911 2SC3117 2SB631 2SB632 2SD600 2SD612		
2SA1302 2SC3281		
2SD1012		
2SC3064 2SC3065		
TERMINAL NAME		
B → BASE C → COLLECTOR E → EMITTER		

LA6458S FRONT / BOTTOM VIEWS

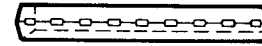
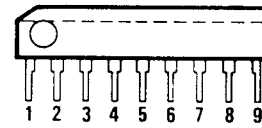

IR2E19 BOTTOM VIEW

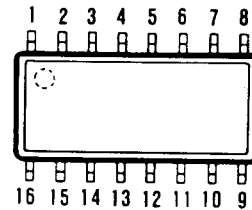

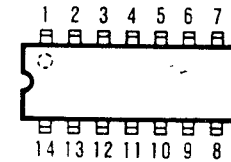

LC4066B BOTTOM VIEW

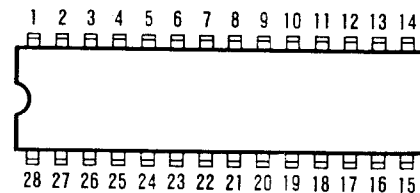

LC7815 BOTTOM VIEW



PRODUCT SAFETY NOTICE

Each precaution in this manual should be followed during servicing. Components identified with the IEC symbol  in the parts list and the schematic diagram designate components in which safety can be of special significance. When replacing a component identified with , use only the replacement parts designated, or parts with the same ratings of resistance, wattage or voltage that are designated in the parts list in this manual. Leakage-current or resistance measurements must be made to determine that exposed parts are acceptably insulated from the supply circuit before returning the product to the customer.

NOTES:

- All resistors values are indicated in "ohm" (K = 10³, M = 10⁶).
- All capacitors values are indicated in "μF" (P = 10⁻¹²).
- All voltages indicated on the schematics are measured under the following conditions:
 - Use a V.T.V.M.
 - All voltages ± 10% with respect to chassis ground
 - No signals at input terminals
 - AC input at 220 volts 50 Hz
 - This is a basic schematic diagram.

Because Fisher products are subject to continuous improvement, Fisher Corporation reserves the right to make any changes or modifications without notice.