

SERVICE MANUAL



FISHER

INTEGRATED STEREO AMPLIFIER

CA-345

(EUROPE)

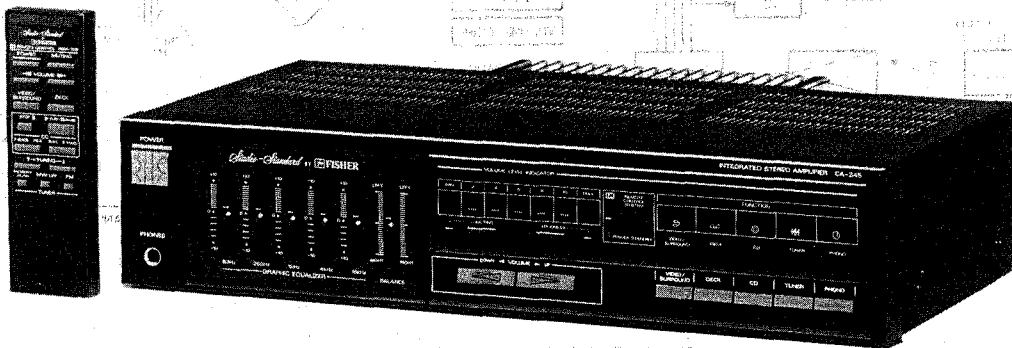

IMPORTANT NOTE

132 327 41

SPECIFICATIONS

System Integrated Stereo Amplifier
 Remote Control (REM-335) 15-function, wireless remote control

POWER AMPLIFIER SECTION

Minimum RMS sine wave power per channel within stated bandwidth at no more than stated distortion and with 8-ohm load 55 Watts
 Power Bandwidth 20 Hz - 20 kHz
 Total Harmonic Distortion 0.5 %
 I.M. Distortion 0.5 %
 Speaker Damping > 20

PREAMPLIFIER SECTION

Frequency Response
 Phono (RIAA) ±1 dB
 Aux (20 Hz - 20 kHz) ±1 dB
 Input Sensitivity and Impedance
 Phono 2.5 mV/50 kΩ
 Deck/Video/Surround 150 mV/50 kΩ
 Tuner/CD 150 mV/50 kΩ
 Phono Max. Input Capability 150 mV

Graphic Equalizer

63 Hz ±10 dB
 250 Hz ±10 dB
 1 kHz ±10 dB
 4 kHz ±10 dB
 16 kHz ±10 dB

Hum and Noise (IHF Short Circuit, A Network)

Phono 68 dB
 Deck/Video/Surround 85 dB
 Tuner/CD 85 dB

GENERAL

Power Requirements AC 110/220 V (50 Hz) 260 Watts
 AC Outlets 3
 Dimensions (WxHxD) 400 x 91 x 202 mm
 Weight (approx.) 5.4 kg

- Specifications and design are subject to change without notice. -

FUNCTIONAL BLOCK DIAGRAM

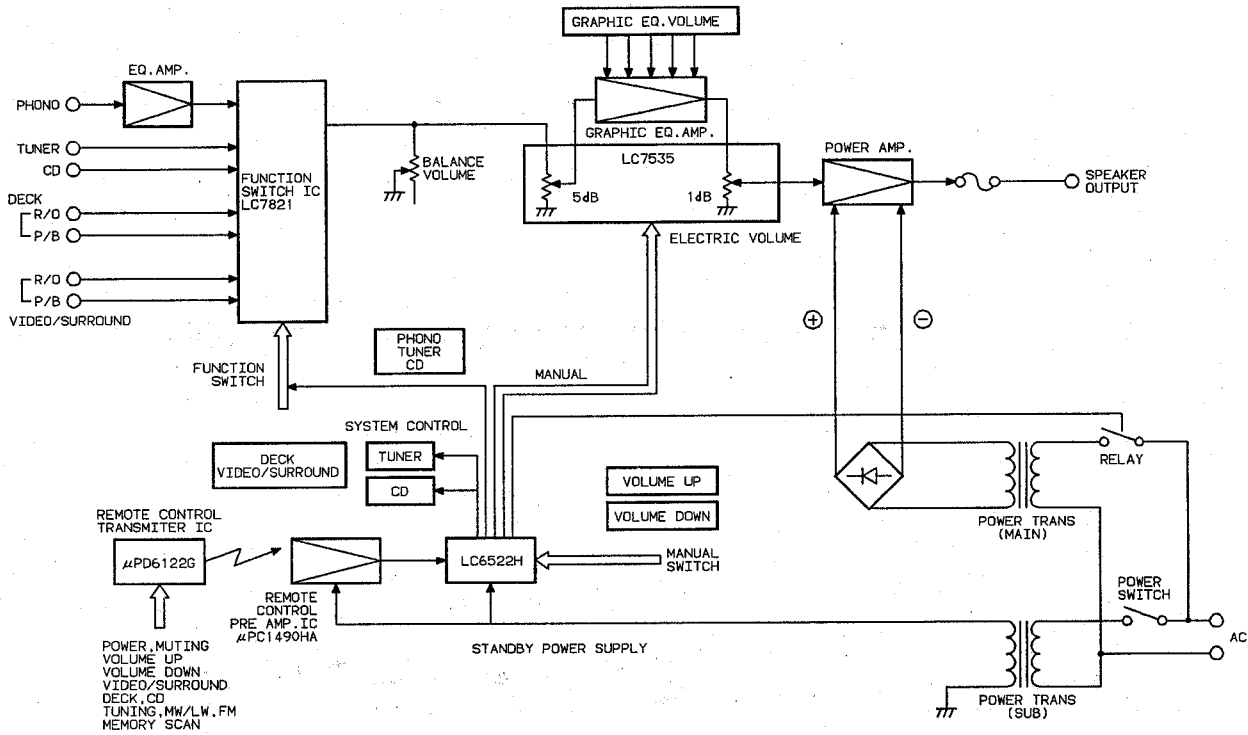

IMPORTANT NOTE

The Amplifier has been Factory-adjusted for operation on 220V AC. The voltage can be changed for operation on 110V AC by making the following changes on the Amplifier inside shown Wiring Diagram below.

1. Remove the AC plug from the wall outlet.
2. Remove the screws securing the cover.
3. Disconnect White lead from Power Trans (Main) Terminal No.2, and then connect it to Power Trans (Main) Terminal No.4.
4. Disconnect Black lead from Power Trans (Main) Terminal No.4, and then connect it to Power Trans (Main) Terminal No.5.
5. Disconnect Green lead W803 from Sub Trans P.C.Board Right Terminal and then connect it to sub Trans.

The Amplifier is now ready 110V operation. DO NOT attempt to operate the Amplifier on 220V. Damage will result !

WIRING DIAGRAM (Power Supply Section)

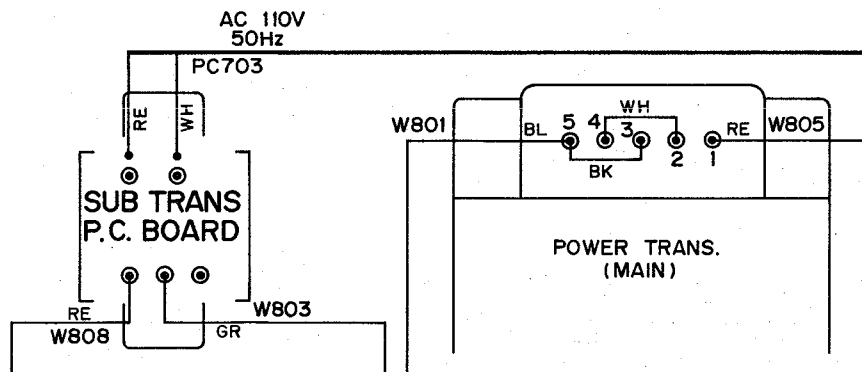

CABINET & CHASSIS PARTS LIST/EXPLODED VIEW

Ref. No.	Part No.	Description	Q'ty
PACKAGE			
	620 000 0024	Bag Polyethylene	1
	620 059 4035	Pad Right	1
	620 059 4042	Pad Left	1
	620 059 6596	Patching Sheet	1
	620 062 0543	Serial No. Sheet	2
	620 184 3255	Box Corrugate-Exp.	1
	620 148 8029	Sheet Polyethylene	1
ACCESSORIES			
	620 004 1447	REM-335 (Remote Control)	1
	620 057 8783	Bag Fan	1
	620 062 0543	Serial No. Sheet	1
	620 152 2624	Certificate Card	1
	620 184 7154	Explanatory Booklet	1
CABINET			
	620 062 0543	Serial No. Sheet	1
	620 125 8424	Wire Band	21
1	620 183 0545	Cabinet Front Assy	1
	620 183 0613	Plate Decorate (G-EQ)	1
	620 183 0668	Plate Decorate	1
	620 183 0729	Cabinet Front	1
	620 047 4191	Leg	2
	620 050 3679	Filter	1
2	620 045 5787	Cover	1
3	620 183 0774	Cover Bottom	1
4	620 183 0781	Cover Heat Sink	1
5	620 046 5342	Knob	1
6	620 183 0804	Knob Volume	1
7	620 046 8336	Knob Function	1
8	620 047 3842	Leg	2
9	620 048 4541	Metal Reinforce	2
10	620 048 4800	Metal Reinforce	1
11	620 183 0859	Chassis	1
12	620 183 0903	Panel Rear	1
13	620 050 2726	Metal Mount Switch	1
14	620 050 2733	Metal Mount Switch	1
15	620 185 2790	Metal Sever	1
16	620 050 4225	Mount P.C.B.	2
17	620 183 0958	Metal Mount Trans	1
18	620 051 1735	Screw, Brazier Hd. Tapping-C, + M3.0X8	2
19	620 051 2152	Screw Ground	1
20	620 051 3692	Screw, Brazier Hd. Tapping-B, + M3.0X6	2
21	620 051 3708	Screw, Brazier Hd. Tapping-B, + M3.0X8	4
22	620 051 3715	Screw, Brazier Hd. Tapping-B, + M3X14	2
23	620 183 1078	Plate Shield	1
24	620 184 9509	Plate Shield	1
25	620 183 1160	Plate Sever	1
26	620 053 2136	Bushing	1
27	620 183 1184	Heat Sink	1
28	620 110 9658	Knob Cap	6
29	620 111 4386	Knob Index	2
30	620 123 0833	Screw, Bind Hd. Tapping-C, + M4X10	4
31	620 122 9738	Screw, Bind Hd. Tapping, + M3.0X8	4
41	620 183 4314	Main P.C.B. Assy	1
42	620 183 4321	Control P.C.B. Assy	1
43	620 183 4338	Volume P.C.B. Assy	1
44	620 183 4345	R/C P.C.B. Assy	1
45	620 183 4352	Speaker Out P.C.B. Assy	1
46	620 183 4369	Power Switch P.C.B. Assy	1
47	620 183 4376	Power Supply P.C.B. Assy	1
48	620 183 4383	Sub Trans P.C.B. Assy	1
49	620 183 4406	EC Terminal P.C.B. Assy	1
50	620 183 4413	Power TR. P.C.B. Assy	1
51	620 184 9691	Sub Trans 1 P.C.B. Assy	1
52	620 006 1490	Slide Volume Unit	1
53	620 017 1212	AC Socket	3
54	620 023 7550	Power Cord	1
55	620 182 9778	Power Trans (Sub)	1
56	620 182 9846	Power Trans (Main)	1
57	405 022 1606	TR 2SD1289-Q [Q104]	1
or	405 080 6100	TR 2SD1289-R	1
or	405 080 7800	TR 2SC3181N-O	1
or	405 080 7909	TR 2SC3181N-R	1
58	405 009 6600	TR 2SB966-Q [Q105]	1
or	405 080 6209	TR 2SB966-R	1
or	405 080 7602	TR 2SA1264N-O	1

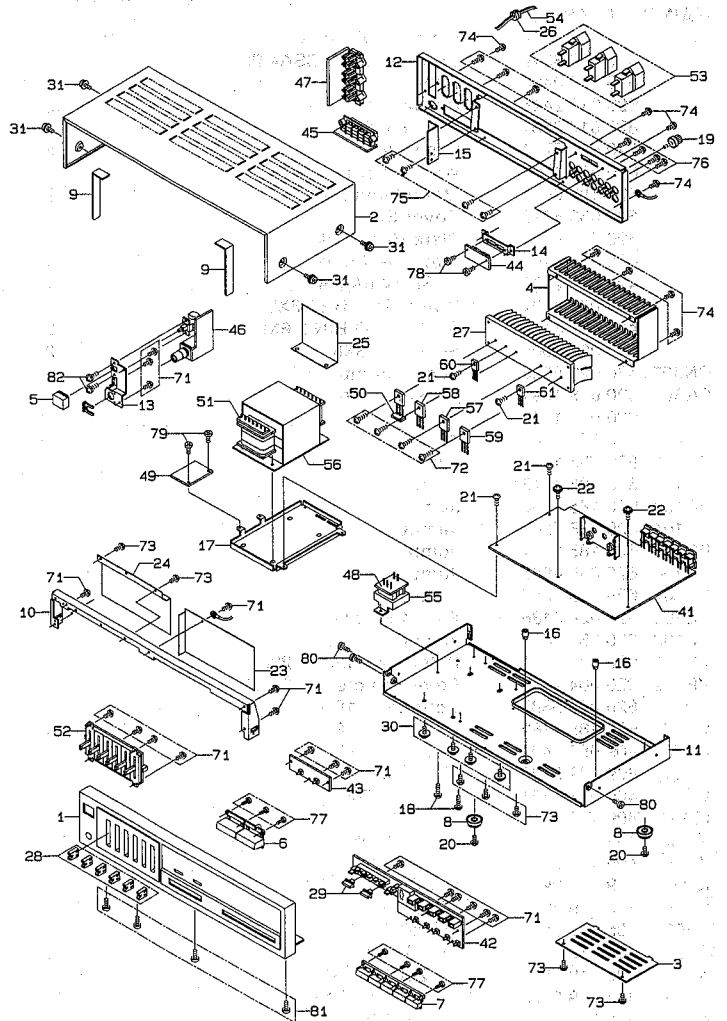

Ref. No.	Part No.	Description	Q'ty
or	405 080 7701	TR 2SA1264N-R	1
59	405 009 6600	TR 2SB966-Q [Q106]	1
or	405 080 6209	TR 2SB966-R	1
or	405 080 7602	TR 2SA1264N-O	1
or	405 080 7701	TR 2SA1264N-R	1
60	405 026 0803	TR 2SD947 [Q701]	1
61	405 026 0803	TR 2SD947 [Q702]	1
71	411 020 5706	SCR S-TPG BRZ 2.6X8	20
72	411 020 5904	SCR S-TPG BRZ 3X10	4
73	411 020 7700	SCR S-TPG BRZ 3X6	7
74	411 099 9704	SCR S-TPG BRZ 3X6	8
75	411 020 8004	SCR S-TPG BRZ 3X8	4
76	411 099 9803	SCR S-TPG BRZ 3X8	7
77	411 021 1202	SCR S-TPG BIN 2X8	7
78	411 021 2704	SCR S-TPG BIN 2.6X6	2
79	411 021 3107	SCR S-TPG BIN 2.6X8	2
80	411 021 5705	SCR S-TPG BIN 3X6	3
81	411 021 6603	SCR S-TPG BIN 3X8	4
82	411 003 8908	SCR PAN + SW 3X6	2

NOTES:

- Parts order must contain Model Number, Part Number and Description.
- Ordering quantity of screws and resistors must be multiple of 10 pcs.

P.C.BOARD PARTS LIST

Ref. No.	Part No.	Description	Q'ty	Ref. No.	Part No.	Description	Q'ty
MAIN P.C.B. ASSY							
41	620 183 4314	Main P.C.B. Assy	1	Q904	405 010 9607	TR 2SC1571-F-NP	1
	620 007 3349	Ceramic.OSC CSA4.00	1	or	405 010 9706	TR 2SC1571-G-NP	1
	620 017 0406	Relay	1	Q905	405 018 0101	TR 2SC3331-T	1
	620 017 2448	Pin Jack 4P	2	or	405 018 0200	TR 2SC3331-U	1
	620 017 2561	Pin Jack 6P	1	Q906	405 018 0101	TR 2SC3331-T	1
	620 017 2721	Fuse Clip	8	or	405 018 0200	TR 2SC3331-U	1
	620 031 4763	Wire Wrap Terminal	2	Q907	405 018 0101	TR 2SC3331-T	1
	620 183 0910	Metal Mount (IC)	2	or	405 018 0200	TR 2SC3331-U	1
	620 053 6899	Cover Safety	1	Q908	405 018 0101	TR 2SC3331-T	1
	620 053 9241	Plate Heat Sink	1	or	405 018 0200	TR 2SC3331-U	1
	620 183 1191	Plate Heat Sink	1	Q909	405 018 0101	TR 2SC3331-T	1
△	423 007 2103	FUSE T4.0A 250V	4	or	405 018 0200	TR 2SC3331-U	1
	411 020 8004	SCR S-TPG BRZ 3X8	1	Q910	405 018 0101	TR 2SC3331-T	1
	411 021 3107	SCR S-TPG BIN 2.6X8	2	or	405 018 0200	TR 2SC3331-U	1
	411 002 9005	SCR PAN 3X8	2	D101	407 008 0405	DIODE GMB01	1
CN302	620 020 5825	Socket Jumper 8P	1	D102	407 008 0405	DIODE GMB01	1
CN303	620 018 1891	Socket Jumper 9P	1	D103	407 092 4105	DIODE DSA20TC-KD3	1
L101	620 027 1240	AF Coil	1	D104	407 092 4105	DIODE DSA20TC-KD3	1
L102	620 027 1240	AF Coil	1	D105	407 092 4105	DIODE DSA20TC-KD3	1
PC101	620 185 1243	Jumper	1	D106	407 092 4105	DIODE DSA20TC-KD3	1
PC102	620 185 1243	Jumper	1	D107	407 049 7807	ZENER DIODE GZA18Y-BT	1
PC103	620 185 1250	Jumper	1	D108	407 049 7807	ZENER DIODE GZA18Y-BT	1
PC104	620 185 1267	Jumper	1	D109	407 088 6502	DIODE MPG06D-PKG3	1
PC105	620 185 1274	Jumper	1	D110	407 050 5502	ZENER DIODE GZA5.6Y-BT	1
PC106	620 055 4985	Jumper	1	D112	407 088 6502	DIODE MPG06D-PKG3	1
PC107	620 183 1382	Jumper	1	D113	407 050 5502	ZENER DIODE GZA5.6Y-BT	1
PC108	620 024 3186	Wire 4 Parallel	1	D114	407 005 3805	DIODE DS442-BT	1
PC109	620 055 3827	Jumper	1	D115	407 005 3805	DIODE DS442-BT	1
VR101	620 004 7319	Potentiometer (B-200Ω)	1	D116	407 008 0405	DIODE GMB01-BT	1
VR102	620 004 7319	Potentiometer (B-200Ω)	1	D200	407 005 1603	DIODE DS135D	1
W101	620 020 5887	Connector 1P Assy	1	D201	407 008 0405	DIODE GMB01	1
W102	620 185 1182	Connector 1P Assy	1	D202	407 008 0405	DIODE GMB01	1
IC101	409 057 4403	IC UPC4570C	1	D901	407 049 7807	ZENER DIODE GZA18Y-BT	1
IC102	409 109 5105	IC LC7821	1	C101	403 018 8509	CERAMIC 220P K 50V	1
IC103	409 057 4601	IC UPC4570HA	1	C102	403 018 8509	CERAMIC 220P K 50V	1
IC104	409 118 0504	IC LC7535	1	C103	403 023 5807	CERAMIC 330P K 50V	1
IC105	409 149 9101	IC UPC1298V	1	C104	403 023 5807	CERAMIC 330P K 50V	1
IC106	409 149 9101	IC UPC1298V	1	C105	403 047 1502	ELECT 4.7U M 25V	1
IC107	409 122 2907	IC LC6522H-3374	1	C106	403 047 1502	ELECT 4.7U M 25V	1
Q101	405 039 5802	TR 2SC3792	1	C107	403 038 2303	ELECT 100U M 6.3V	1
Q102	405 039 5802	TR 2SC3792	1	C108	403 038 2303	ELECT 100U M 6.3V	1
Q107	405 019 2708	TR 2SC536-F-NP	1	C109	403 018 8509	CERAMIC 220P K 50V	1
or	405 019 3804	TR 2SC536-G-NP	1	C110	403 018 8509	CERAMIC 220P K 50V	1
Q108	405 019 2708	TR 2SC536-F-NP	1	C111	403 059 0401	POLYESTER 0.018U K 50V	1
or	405 019 3804	TR 2SC536-G-NP	1	C112	403 059 0401	POLYESTER 0.018U K 50V	1
Q109	405 034 6804	TR DTA114-ES	1	C113	403 061 8709	POLYESTER 4700P K 50V	1
Q110	405 019 2708	TR 2SC536-F-NP	1	C114	403 061 8709	POLYESTER 4700P K 50V	1
or	405 019 3804	TR 2SC536-G-NP	1	C115	403 047 1502	ELECT 4.7U M 25V	1
Q111	405 023 8307	TR 2SD438-E-MP	1	C116	403 047 1502	ELECT 4.7U M 25V	1
or	405 023 8505	TR 2SD438-F-MP	1	C117	403 018 8509	CERAMIC 220P K 50V	1
Q112	405 007 5100	TR 2SB560-E-MP	1	C118	403 018 8509	CERAMIC 220P K 50V	1
or	405 007 5308	TR 2SB560-F-MP	1	C119	403 018 8509	CERAMIC 220P K 50V	1
Q113	405 035 7107	TR 2SD1913-R	1	C120	403 018 8509	CERAMIC 220P K 50V	1
or	405 035 7206	TR 2SD1913-S	1	C123	403 018 8509	CERAMIC 220P K 50V	1
Q114	405 004 4502	TR 2SA608-F-NP	1	C124	403 018 8509	CERAMIC 220P K 50V	1
or	405 004 5004	TR 2SA608-G-NP	1	C127	403 018 8509	CERAMIC 220P K 50V	1
Q115	405 019 2708	TR 2SC536-F-NP	1	C128	403 018 8509	CERAMIC 220P K 50V	1
or	405 019 3804	TR 2SC536-G-NP	1	C131	403 018 8509	CERAMIC 220P K 50V	1
Q116	405 004 4502	TR 2SA608-F-NP	1	C132	403 018 8509	CERAMIC 220P K 50V	1
or	405 004 5004	TR 2SA608-G-NP	1	C135	403 018 8509	CERAMIC 220P K 50V	1
Q117	405 019 2708	TR 2SC536-F-NP	1	C136	403 018 8509	CERAMIC 220P K 50V	1
or	405 019 3804	TR 2SC536-G-NP	1	C139	403 018 8509	CERAMIC 220P K 50V	1
Q118	405 019 2708	TR 2SC536-F-NP	1	C140	403 018 8509	CERAMIC 220P K 50V	1
or	405 019 3804	TR 2SC536-G-NP	1	C143	403 047 4305	ELECT 47U M 25V	1
Q220	405 019 2708	TR 2SC536-F-NP	1	C144	403 047 4305	ELECT 47U M 25V	1
or	405 019 3804	TR 2SC536-G-NP	1	C145	403 049 1609	ELECT 1U M 50V	1
Q250	405 019 2708	TR 2SC536-F-NP	1	C147	403 047 4305	ELECT 47U M 25V	1
or	405 019 3804	TR 2SC536-G-NP	1	C148	403 047 4305	ELECT 47U M 25V	1
Q251	405 019 2708	TR 2SC536-F-NP	1	C149	403 047 4305	ELECT 47U M 25V	1
or	405 019 3804	TR 2SC536-G-NP	1	C150	403 047 4305	ELECT 47U M 25V	1
Q252	405 006 6504	TR 2SA984-E	1	C153	403 029 0509	CERAMIC 560P K 50V	1
or	405 006 6702	TR 2SA984-F	1	C154	403 029 0509	CERAMIC 560P K 50V	1
Q901	405 010 9607	TR 2SC1571-F-NP	1	C155	403 063 8103	POLYESTER 0.082U K 50V	1
or	405 010 9706	TR 2SC1571-G-NP	1	C156	403 063 8103	POLYESTER 0.082U K 50V	1
Q902	405 010 9607	TR 2SC1571-F-NP	1	C159	403 047 1502	ELECT 4.7U M 25V	1
or	405 010 9706	TR 2SC1571-G-NP	1	C160	403 047 1502	ELECT 4.7U M 25V	1
Q903	405 010 9607	TR 2SC1571-F-NP	1	C161	403 009 8105	CERAMIC 100P K 50V	1
or	405 010 9706	TR 2SC1571-G-NP	1	C162	403 009 8105	CERAMIC 100P K 50V	1
				C163	403 009 8105	CERAMIC 100P K 50V	1

P.C. BOARD PARTS LIST (Continued)

Ref. No.	Part No.	Description	Q'ty	Ref. No.	Part No.	Description	Q'ty
C164	403 009 8105	CERAMIC 100P K 50V	1	C919	403 031 2805	CERAMIC 680P K 50V	1
C165	403 008 5204	CERAMIC 10P D 50V	1	C920	403 031 2805	CERAMIC 680P K 50V	1
C166	403 008 5204	CERAMIC 10P D 50V	1	C921	403 061 8709	POLYESTER 4700P K 50V	1
C167	403 042 0302	ELECT 10U M 16V	1	C922	403 061 8709	POLYESTER 4700P K 50V	1
C168	403 042 0302	ELECT 10U M 16V	1	C925	403 047 1502	ELECT 4.7U M 25V	1
C169	403 050 1209	ELECT 2.2U M 50V	1	R101	401 024 7004	CARBON 1K JA 1/6W	1
C170	403 050 1209	ELECT 2.2U M 50V	1	R102	401 024 7004	CARBON 1K JA 1/6W	1
C171	403 018 8509	CERAMIC 220P K 50V	1	R103	401 024 7707	CARBON 100K JA 1/6W	1
C172	403 018 8509	CERAMIC 220P K 50V	1	R104	401 024 7707	CARBON 100K JA 1/6W	1
C173	403 074 2701	CERAMIC 0.047U Z 50V	1	R105	401 024 7707	CARBON 100K JA 1/6W	1
C174	403 074 2701	CERAMIC 0.047U Z 50V	1	R106	401 024 7707	CARBON 100K JA 1/6W	1
C175	403 047 1502	ELECT 4.7U M 25V	1	R107	401 026 3905	CARBON 330 JA 1/6W	1
C176	403 047 1502	ELECT 4.7U M 25V	1	R108	401 026 3905	CARBON 330 JA 1/6W	1
C183	403 038 9302	ELECT 33U M 6.3V	1	R109	401 025 8703	CARBON 220K JA 1/6W	1
C184	403 038 9302	ELECT 33U M 6.3V	1	R110	401 025 8703	CARBON 220K JA 1/6W	1
C185	403 012 9809	CERAMIC 15P K 50V	1	R111	401 025 1902	CARBON 15K JA 1/6W	1
C186	403 012 9809	CERAMIC 15P K 50V	1	R112	401 025 1902	CARBON 15K JA 1/6W	1
C187	403 121 0803	ELECT 220U M 63V	1	R113	401 024 7707	CARBON 100K JA 1/6W	1
C188	403 121 0803	ELECT 220U M 63V	1	R114	401 024 7707	CARBON 100K JA 1/6W	1
C191	403 062 0900	POLYESTER 0.047U K 50V	1	R115	401 024 7004	CARBON 1K JA 1/6W	1
C192	403 062 0900	POLYESTER 0.047U K 50V	1	R116	401 024 7004	CARBON 1K JA 1/6W	1
C193	403 074 2701	CERAMIC 0.047U Z 50V	1	R117	401 024 7004	CARBON 1K JA 1/6W	1
C194	403 074 2701	CERAMIC 0.047U Z 50V	1	R118	401 024 7004	CARBON 1K JA 1/6W	1
C195	403 039 2906	ELECT 47U M 6.3V	1	R121	401 024 7004	CARBON 1K JA 1/6W	1
C197	404 012 7000	CERAMIC 0.01U P 500V	1	R122	401 024 7004	CARBON 1K JA 1/6W	1
C198	404 012 7000	CERAMIC 0.01U P 500V	1	R125	401 024 7004	CARBON 1K JA 1/6W	1
C199	404 012 7000	CERAMIC 0.01U P 500V	1	R126	401 024 7004	CARBON 1K JA 1/6W	1
C200	404 012 7000	CERAMIC 0.01U P 500V	1	R129	401 024 7004	CARBON 1K JA 1/6W	1
C201	620 006 6877	Capacitor 4700MF 55V	1	R130	401 024 7004	CARBON 1K JA 1/6W	1
C202	620 006 6877	Capacitor 4700MF 55V	1	R133	401 024 7004	CARBON 1K JA 1/6W	1
C203	403 051 3806	ELECT 47U M 50V	1	R134	401 024 7004	CARBON 1K JA 1/6W	1
C204	403 051 3806	ELECT 47U M 50V	1	R137	401 024 7004	CARBON 1K JA 1/6W	1
C205	403 047 1502	ELECT 4.7U M 25V	1	R138	401 024 7004	CARBON 1K JA 1/6W	1
C206	403 047 1502	ELECT 4.7U M 25V	1	R141	401 018 3807	CARBON 3.3K JA 1/4W	1
C207	403 047 4305	ELECT 47U M 25V	1	R142	401 018 3807	CARBON 3.3K JA 1/4W	1
C208	403 047 4305	ELECT 47U M 25V	1	R143	401 012 4503	CARBON 100 JA 1/4W	1
C209	620 006 6679	Capacitor 0.01MF400V	1	R144	401 012 4503	CARBON 100 JA 1/4W	1
C210	403 047 1502	ELECT 4.7U M 25V	1	R145	401 024 7400	CARBON 10K JA 1/6W	1
C211	403 039 4504	ELECT 470U M 6.3V	1	R147	401 012 4503	CARBON 100 JA 1/4W	1
C213	403 042 6205	ELECT 1000U M 16V	1	R148	401 012 4503	CARBON 100 JA 1/4W	1
C214	403 038 4505	ELECT 1000U M 6.3V	1	R149	401 012 4503	CARBON 100 JA 1/4W	1
C215	403 049 1609	ELECT 1U M 50V	1	R150	401 012 4503	CARBON 100 JA 1/4W	1
C216	403 069 8404	CERAMIC 0.01U Z 50V	1	R151	401 024 8001	CARBON 1M JA 1/6W	1
C217	403 042 3600	ELECT 100U M 16V	1	R152	401 024 8001	CARBON 1M JA 1/6W	1
C218	403 043 3104	ELECT 2200U M 16V	1	R153	401 025 8703	CARBON 220K JA 1/6W	1
C219	403 042 0302	ELECT 10U M 16V	1	R154	401 025 8703	CARBON 220K JA 1/6W	1
C220	403 049 1609	ELECT 1U M 50V	1	R155	401 027 2600	CARBON 5.6K JA 1/6W	1
C221	403 049 1609	ELECT 1U M 50V	1	R156	401 027 2600	CARBON 5.6K JA 1/6W	1
C222	403 047 9607	ELECT 0.1U M 50V	1	R157	401 026 9907	CARBON 4.7K JA 1/6W	1
C223	403 022 5907	CERAMIC 33P J 50V	1	R158	401 026 9907	CARBON 4.7K JA 1/6W	1
C224	403 022 5907	CERAMIC 33P J 50V	1	R161	401 024 7004	CARBON 1K JA 1/6W	1
C225	403 074 2701	CERAMIC 0.047U Z 50V	1	R162	401 024 7004	CARBON 1K JA 1/6W	1
C226	403 018 8509	CERAMIC 220P K 50V	1	R163	401 024 7707	CARBON 100K JA 1/6W	1
C227	403 018 8509	CERAMIC 220P K 50V	1	R164	401 024 7707	CARBON 100K JA 1/6W	1
C232	403 018 8509	CERAMIC 220P K 50V	1	R165	401 027 2600	CARBON 5.6K JA 1/6W	1
C233	403 018 8509	CERAMIC 220P K 50V	1	R166	401 021 3009	CARBON 5.6K JA 1/4W	1
C234	403 018 8509	CERAMIC 220P K 50V	1	R167	402 039 3203	FUSIBLE RES 33 JA 1/4W	1
C235	403 018 8509	CERAMIC 220P K 50V	1	R168	402 039 3203	FUSIBLE RES 33 JA 1/4W	1
C236	403 018 8509	CERAMIC 220P K 50V	1	R169	401 025 1902	CARBON 15K JA 1/6W	1
C250	403 054 5906	ELECT 10U M 100V	1	R170	401 025 1902	CARBON 15K JA 1/6W	1
C251	403 039 7802	ELECT 100U M 10V	1	R173	401 027 5908	CARBON 68K JA 1/6W	1
C901	403 047 4305	ELECT 47U M 25V	1	R174	401 027 5908	CARBON 68K JA 1/6W	1
C902	403 047 4305	ELECT 47U M 25V	1	R175	401 025 3005	CARBON 1.6K JA 1/6W	1
C903	403 059 6601	POLYESTER 0.022U K 50V	1	R176	401 025 3005	CARBON 1.6K JA 1/6W	1
C904	403 059 6601	POLYESTER 0.022U K 50V	1	R179	402 039 3203	FUSIBLE RES 33 JA 1/4W	1
C905	403 050 8000	ELECT 3.3U M 50V	1	R180	402 039 3203	FUSIBLE RES 33 JA 1/4W	1
C906	403 050 8000	ELECT 3.3U M 50V	1	R181	401 015 6504	CARBON 2.2 JA 1/4W	1
C907	403 057 0908	POLYESTER 0.01U K 50V	1	R182	401 015 6504	CARBON 2.2 JA 1/4W	1
C908	403 057 0908	POLYESTER 0.01U K 50V	1	R183	401 027 5908	CARBON 68K JA 1/6W	1
C909	403 048 7909	ELECT 0.47U M 50V	1	R184	401 027 5908	CARBON 68K JA 1/6W	1
C910	403 048 7909	ELECT 0.47U M 50V	1	R185	401 015 6504	CARBON 2.2 JA 1/4W	1
C911	403 061 8709	POLYESTER 4700P K 50V	1	R186	401 015 6504	CARBON 2.2 JA 1/4W	1
C912	403 061 8709	POLYESTER 4700P K 50V	1	R187	401 064 0300	OXIDE-MT 0.22 JB 2W	1
C913	403 063 8103	POLYESTER 0.082U K 50V	1	R188	401 064 0300	OXIDE-MT 0.22 JB 2W	1
C914	403 063 8103	POLYESTER 0.082U K 50V	1	R189	401 064 0300	OXIDE-MT 0.22 JB 2W	1
C915	403 058 1607	POLYESTER 1500P K 50V	1	R190	401 064 0300	OXIDE-MT 0.22 JB 2W	1
C916	403 058 1607	POLYESTER 1500P K 50V	1	R191	401 019 6203	CARBON 4.7 JA 1/4W	1
C917	403 059 6601	POLYESTER 0.022U K 50V	1	R192	401 019 6203	CARBON 4.7 JA 1/4W	1
C918	403 059 6601	POLYESTER 0.022U K 50V	1	R193	401 054 7500	OXIDE-MT 10 JB 1/2W	1

P.C. BOARD PARTS LIST (Continued)

Ref. No.	Part No.	Description	Q'ty
R311	401 025 7805	CARBON 2.2K JA 1/6W	1
R312	401 014 2903	CARBON 150 JA 1/4W	1
R313	401 014 2903	CARBON 150 JA 1/4W	1
R314	401 014 2903	CARBON 150 JA 1/4W	1
R315	401 014 2903	CARBON 150 JA 1/4W	1
R316	401 025 7805	CARBON 2.2K JA 1/6W	1
R317	401 027 5007	CARBON 68 JA 1/6W	1
VOLUME P.C.B. ASSY			
43	620 183 4338	Volume P.C.B. Assy	1
SW308	620 016 7796	Tact Switch (UP)	1
SW309	620 016 7796	Tact Switch (DOWN)	1
D318	407 008 0405	DIODE GMB01-BT	1
D319	407 008 0405	DIODE GMB01-BT	1
R/C P.C.B. ASSY			
44	620 183 4345	R/C P.C.B. Assy	1
CN401	620 021 5947	Plug 5P (TUNER)	1
CN402	620 021 5930	Plug 4P (CD)	1
R401	401 024 7004	CARBON 1K JA 1/6W	1
R402	401 024 7004	CARBON 1K JA 1/6W	1
R403	401 024 7004	CARBON 1K JA 1/6W	1
R404	401 024 7004	CARBON 1K JA 1/6W	1
SPEAKER OUT P.C.B. ASSY			
45	620 183 4352	Speaker Out P.C.B. Assy	1
	620 022 5151	4P Push Terminal (Speaker)	1
W601	620 020 5887	Connector 1P Assy	1
C601	403 069 1504	CERAMIC 1000P K 50V	1
C602	403 069 1504	CERAMIC 1000P K 50V	1
C603	403 069 4000	CERAMIC 1000P Z 50V	1
C604	403 069 4000	CERAMIC 1000P Z 50V	1
POWER SWITCH P.C.B. ASSY			
46	620 183 4369	Power Switch P.C.B. Assy	1
	620 017 1915	Jack 7P 6.45	1
	620 123 3025	Cover Capacitor	1
SW501	620 015 2341	Switch Push Power	1
PC501	620 182 9440	Wire 4 Parallel	1
C501	620 006 6716	Capacitor 1000P 400V	1
R501	401 067 9102	OXIDE-MT 390 JB 2W	1
R502	401 067 9102	OXIDE-MT 390 JB 2W	1
R503	401 111 5807	OXIDE-MT 120 JB 1/2W	1
R504	401 111 5807	OXIDE-MT 120 JB 1/2W	1

Ref. No.	Part No.	Description	Q'ty
POWER SUPPLY P.C.B. ASSY			
47	620 183 4376	Power Supply P.C.B. Assy	1
	620 017 2721	Fuse Clip	4
	620 017 7153	Socket 2P	1
	620 017 7160	Socket 2P	1
	620 017 7177	Socket 2P	1
△	423 005 0507	FUSE T1.0A 250V	2
SUB TRANS P.C.B. ASSY			
48	620 183 4383	Sub Trans P.C.B. Assy	1
PC703	620 182 9709	Wire 2 Parallel	1
EC TERMINAL P.C.B. ASSY			
49	620 183 4406	EC Terminal P.C.B. Assy	1
	620 017 2721	Fuse Clip	2
	620 022 2587	EC Terminal 1P	2
	620 031 4763	Wire Wrap Terminal	3
△	423 006 4702	FUSE T2.5A 250V	1
POWER TR. P.C.B. ASSY			
50	620 183 4413	Power TR. P.C.B. Assy	1
Q103	405 022 1606	TR 2SD1289-Q	1
or	405 080 6100	TR 2SD1289-R	1
or	405 080 7800	TR 2SC3181N-O	1
or	405 080 7909	TR 2SC3181N-R	1
SUB TRANS 1 P.C.B. ASSY			
51	620 184 9691	Sub Trans 1 P.C.B. Assy	1

NOTES:

- Parts order must contain Model Number, Part Number and Description.
- Ordering quantity of screws and resistors must be multiple of 10 pcs.

PRODUCT SAFETY NOTICE

Each precaution in this manual should be followed during servicing. Components identified with the IEC symbol △ in the parts list and the schematic diagram designate components in which safety can be of special significance. When replacing a component identified with △, use only the replacement parts designated, or parts with the same ratings of resistance, wattage or voltage that are designated in the parts list in this manual. Leakage-current or resistance measurements must be made to determine that exposed parts are acceptably insulated from the supply circuit before returning the product to the customer.

POWER AMPLIFIER ADJUSTMENT

BEFORE ADJUSTMENT

Unplug the AC power cord and set the front panel controls as follows:

- Power Switch to OFF position.
- Set the volume level to minimum level by Pressing the VOLUME DOWN button.
- IDLING CURRENT ADJUSTMENT VR101/VR102 (on the Main P.C.Board) setting to mechanical center position.
- Connect the AC power cord and Power Switch to ON position.

IDLING CURRENT ADJUSTMENT

This adjustment is very sensitive to changes in ambient temperature. Allow set to operate for 2 minutes before attempting this alignment.

LEFT AMPLIFIER

- Connect the DC Voltmeter between Pins TP1 and TP2 on the Main P.C. Board.
- Adjust the VR101 for an indication of 3mV ±0.5mV on the DC Voltmeter.

RIGHT AMPLIFIER

- Connect the DC Voltmeter between Pins TP3 and TP4 on the Main P.C. Board.
- Adjust the VR102 for an indication of 3mV ±0.5mV on the DC Voltmeter.

POWER SWITCH P.C. BOARD (BOTTOM VIEW)

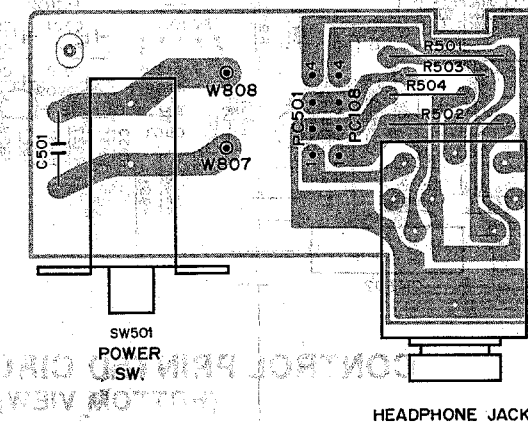

**MAIN PRINTED CIRCUIT BOARD
(BOTTOM VIEW)**

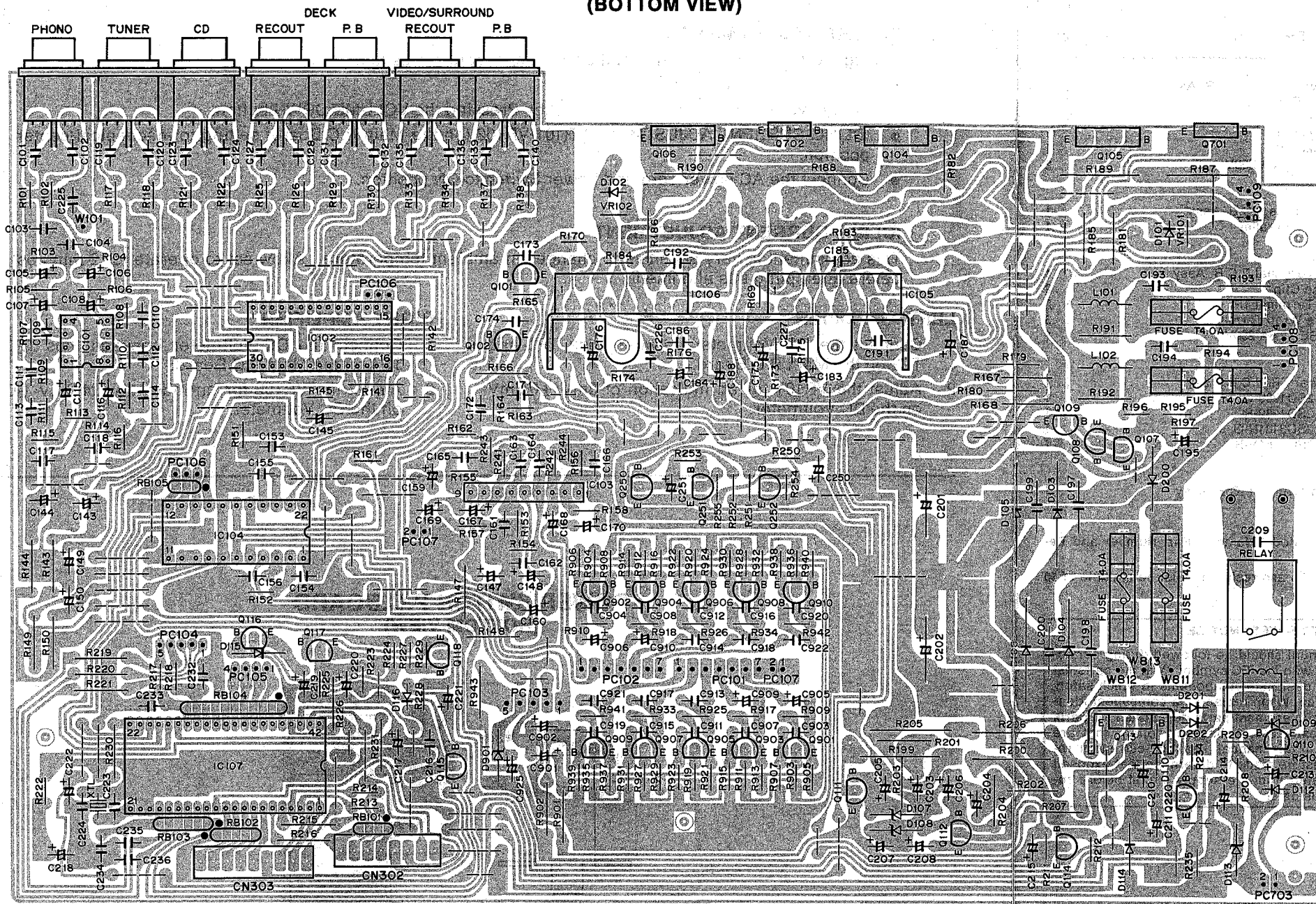

**CONTROL PRINTED CIRCUIT BOARD
(BOTTOM VIEW)**

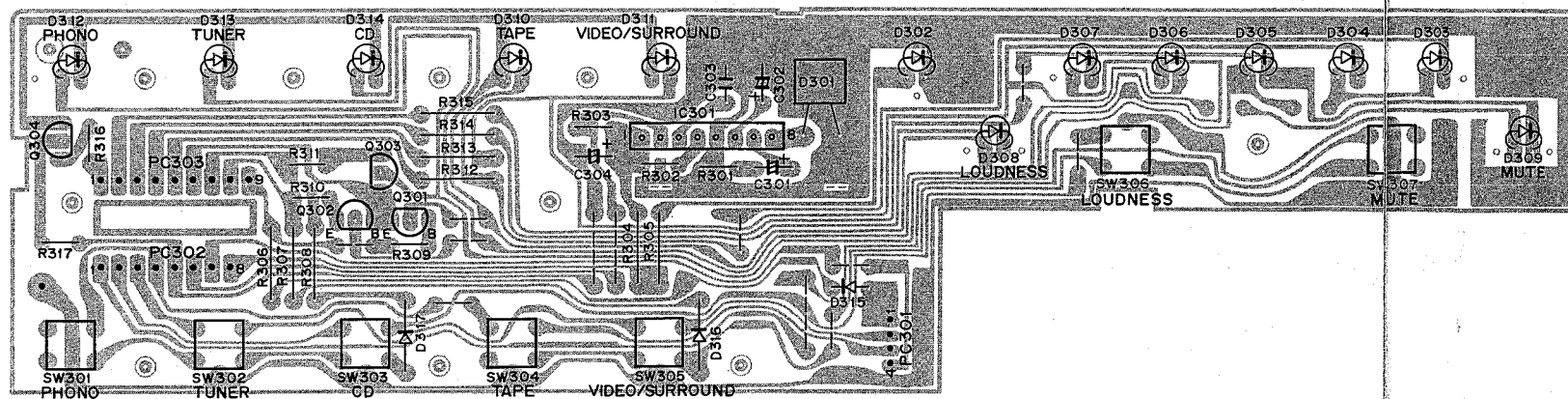

PARTS LIST & EXPLODED VIEW (Remote Control)

Ref. No.	Part No.	Description	Q'ty
REMOTE CONTROL CABINET			
	620 004 1447	REM-335 (Remote Control)	1
	620 057 8462	Bag Polyethylene-Exp.	1
1	620 038 8153	Cabinet Top	1
2	620 038 8160	Cabinet Bottom	1
3	620 040 0206	Lid Battery	1
4	620 040 6147	Plate Decorate	1
5	620 054 1381	Filter	1
6	620 111 7127	Knob Rubber (11 Key)	1
7	620 111 7141	Knob Rubber (4 Key)	1
8	620 122 1305	Spring Battery	1
9	620 080 3144	REM.T.M. P.C.B. Assy	1
REM.T.M. P.C.B. ASSY			
9	620 080 3144	REM.T.M. P.C.B. Assy	1
	620 122 1312	Terminal Anode (+)	1
	620 122 1329	Terminal Anode (-)	1
CR	620 007 3301	Ceramic KBR-455BT	1
IC1	409 121 5909	IC UPD6122G-501	1
TR1	405 021 2505	TR 2SD1048-X8-TA	1
or	405 021 2406	TR 2SD1048-X7-TA	1
D1	407 016 2408	LED LD271E	1
D2	407 036 6301	LED SLP-981C-50	1
C1	403 039 2906	ELECT 47U M 6.3V	1
C2	403 068 9709	CERAMIC 100P K 50V	1
C3	403 068 9709	CERAMIC 100P K 50V	1
R1	402 035 8004	MT-GLAZE 100 JA 1/8W	1
R2	402 033 8303	MT-GLAZE 1 JA 1/8W	1
R3	402 022 9106	MT-GLAZE 15 JA 1/8W	1

NOTES:

- Parts order must contain Model Number, Part Number and Description.
- Ordering quantity of screws and resistors must be multiple of 10 pcs.

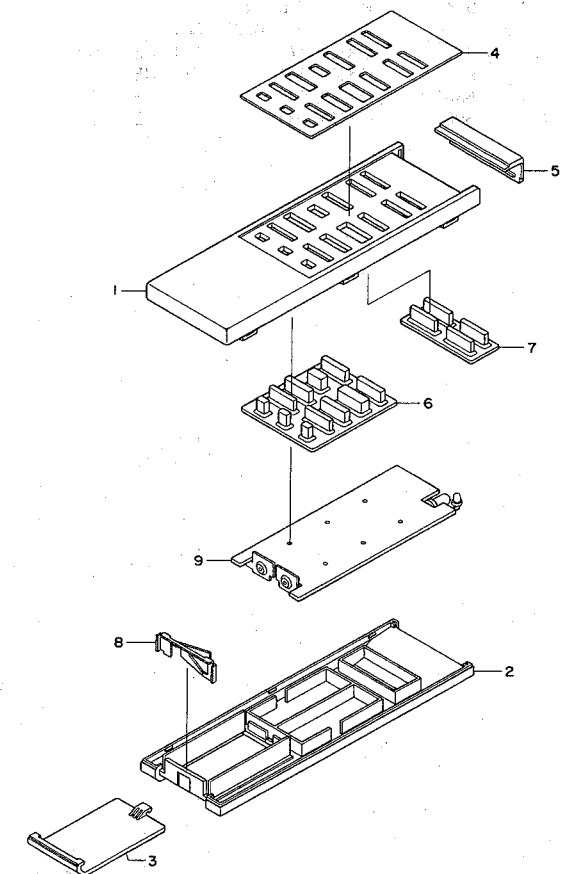

SCHEMATIC DIAGRAM

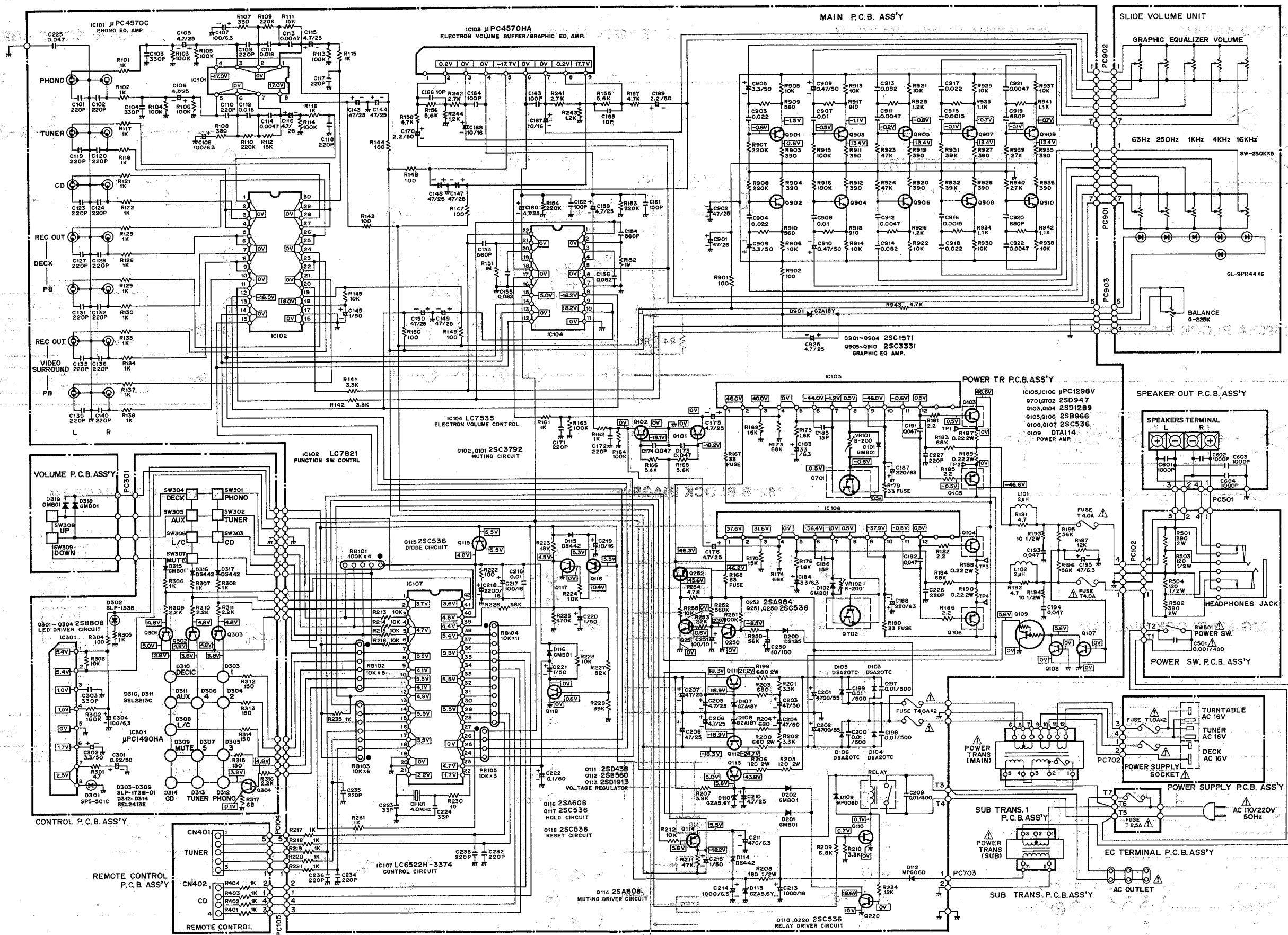

- NOTES:**
1. All resistors values are indicated in "ohm" (K = 10³, M = 10⁶).
 2. All capacitors values are indicated in "μF" (P = 10⁻¹²).
 3. All voltages indicated on the schematics are measured under the following conditions.
 - a. Use a V.T.V.M.
 - b. All voltages ±10 % with respect to chassis ground.
 - c. No signals at input terminals.
 - d. AC input at 220 volts 50 Hz.
 4. This is a basic schematic diagram.

INTEGRATED CIRCUIT BLOCK DIAGRAM

μ PC 4570C BLOCK DIAGRAM

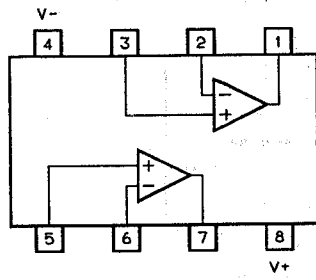

μ PC 4570HA BLOCK DIAGRAM

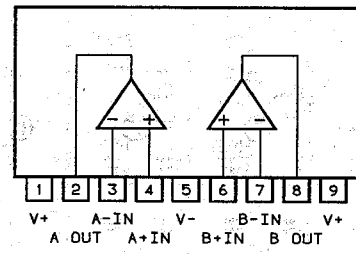

μ PCB 1298V BLOCK DIAGRAM

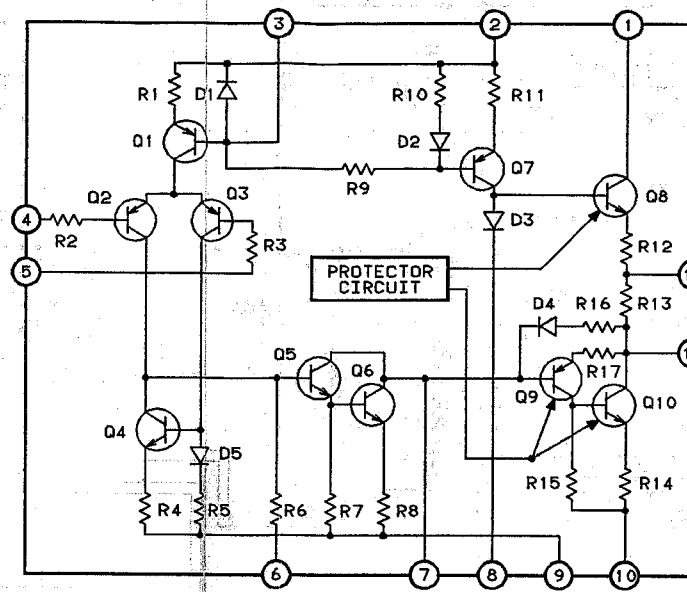

INTEGRATED CIRCUIT BLOCK DIAGRAM (Continued)

LC 7535 BLOCK DIAGRAM

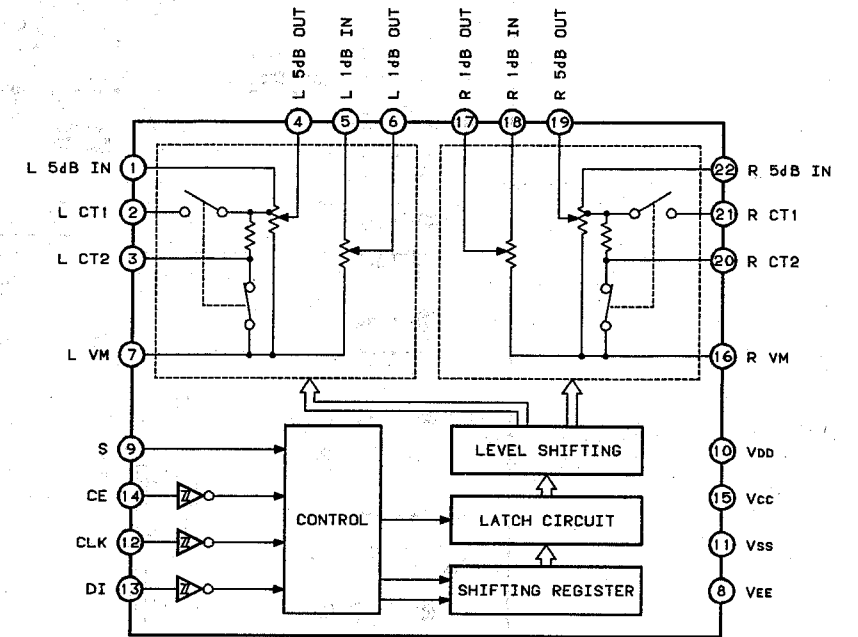

μ PC 1490HA BLOCK DIAGRAM

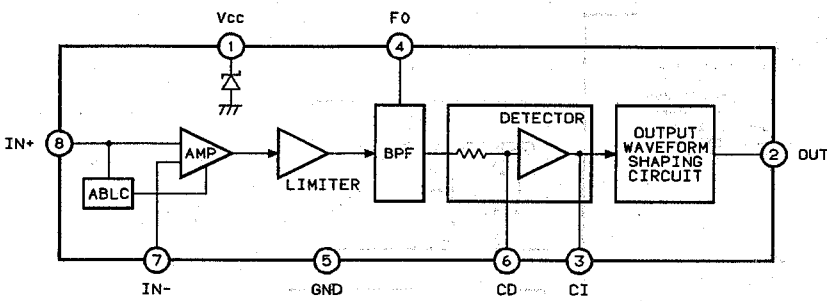

LC 7821B BLOCK DIAGRAM

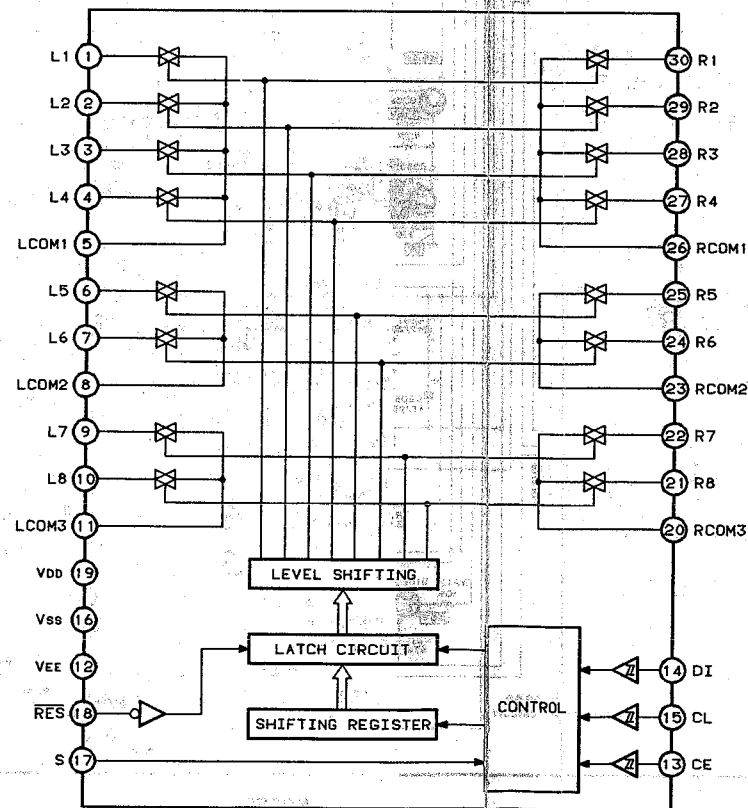

LC 6522H BLOCK DIAGRAM

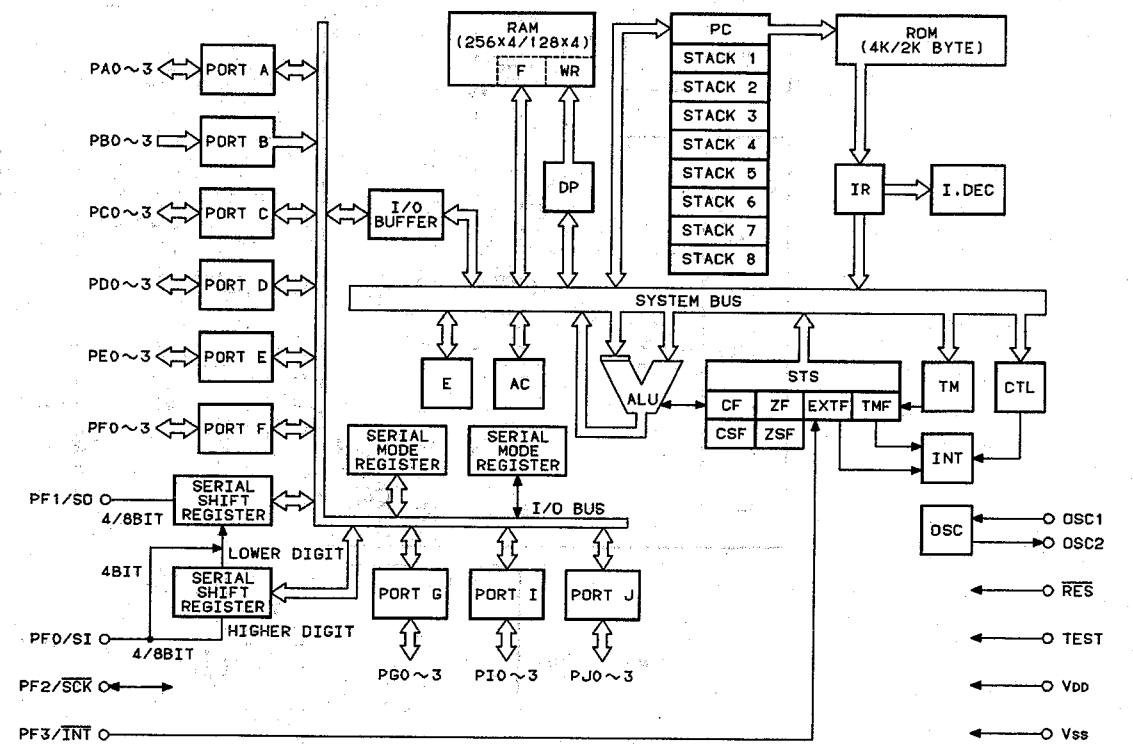

μ PD 6122G-501 BLOCK DIAGRAM

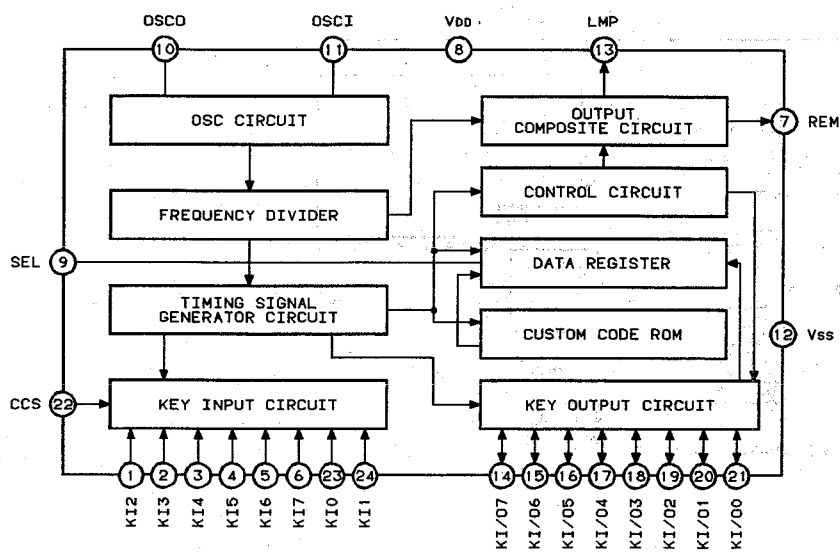



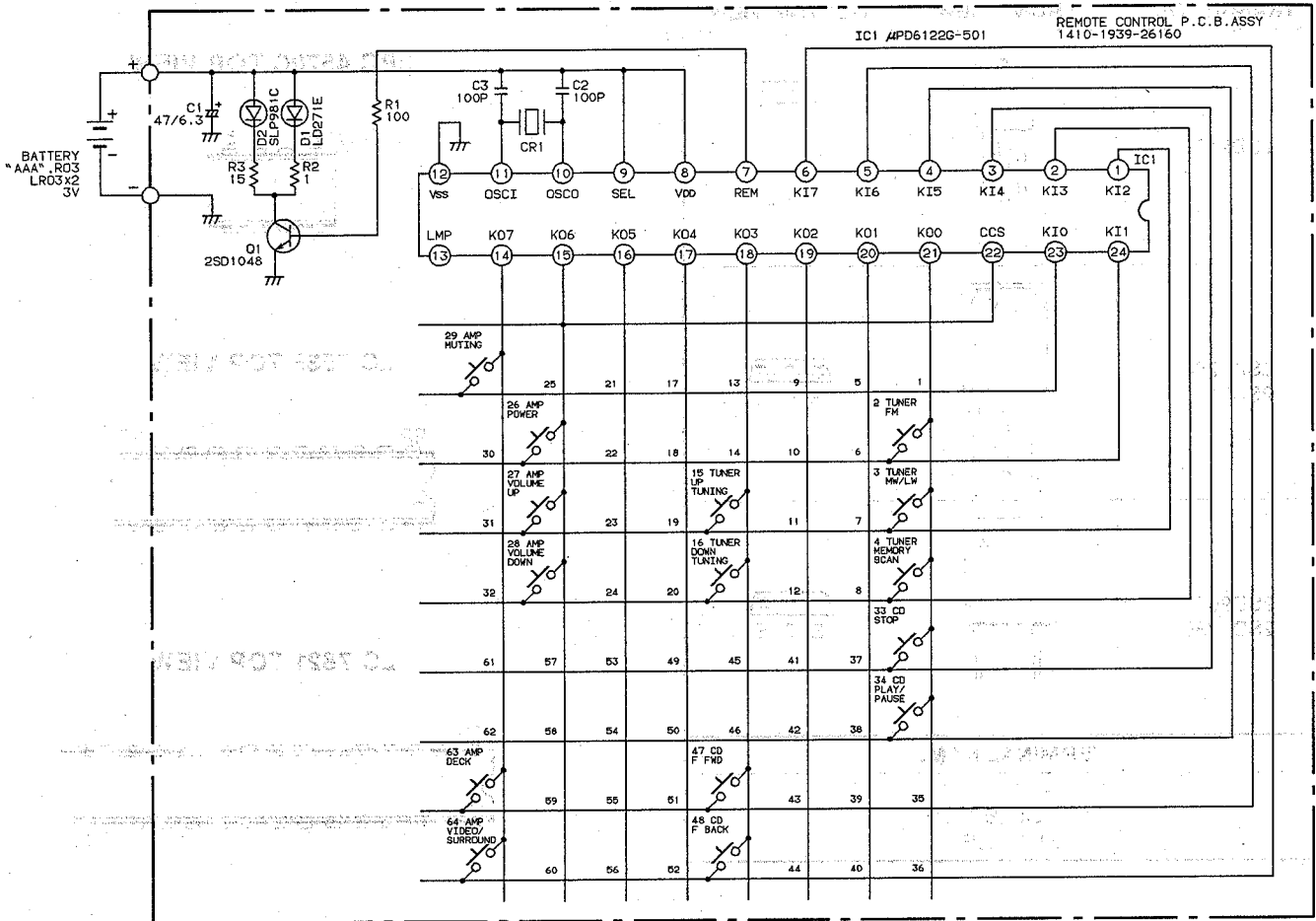



SCHEMATIC DIAGRAM (Remote Control)

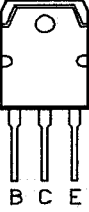

SEMICONDUCTOR LEAD IDENTIFICATION

TRANSISTOR	FRONT VIEW	BOTTOM VIEW	TRANSISTOR	FRONT VIEW	BOTTOM VIEW
2SA608 2SA984 2SC536 2SC1571 2SC3331 2SC3792			2SB560 2SD438		
DTA114 2SB808			2SD1913		
TERMINAL NAME					
B → BASE C → COLLECTOR E → EMITTER					

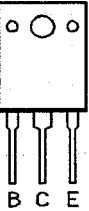
SEMICONDUCTOR LEAD IDENTIFICATION (Continued)

TRANSISTOR	FRONT VIEW	BOTTOM VIEW
2SD947	 <p style="text-align: center;">ECB</p>	 <p style="text-align: center;">ECB</p>
2SA1264 2SC3181	 <p style="text-align: center;">B C E</p>	 <p style="text-align: center;">B C E</p>
2SB966 2SD1289	 <p style="text-align: center;">B C E</p>	 <p style="text-align: center;">B C E</p>
TERMINAL NAME		
B → BASE C → COLLECTOR E → EMITTER		

μPC 4570C TOP VIEW

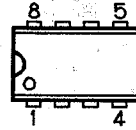

LC 7535 TOP VIEW

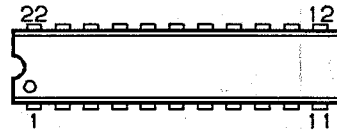

LC 7821 TOP VIEW

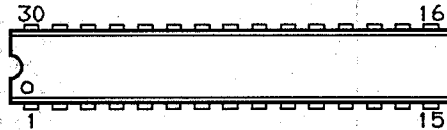

μPC 1490HA FRONT/SIDE VIEWS

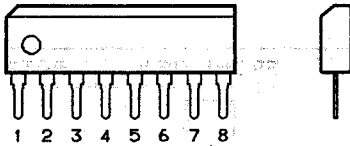

LC 6522H-3374 TOP VIEW

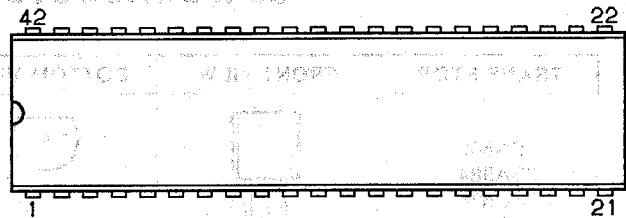

μPC 4570HA FRONT/SIDE VIEWS

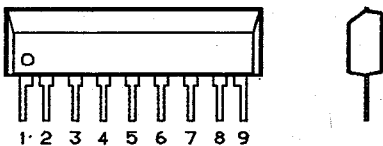

μPC 1298V FRONT/SIDE VIEWS

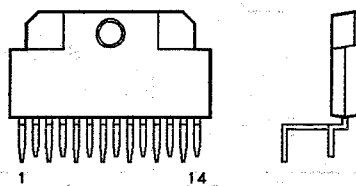

μPD 6122G-501 TOP/SIDE VIEWS

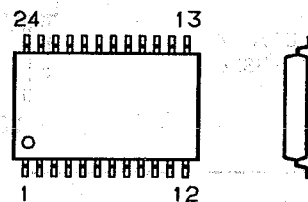

POINT TO POINT WIRING DIAGRAM

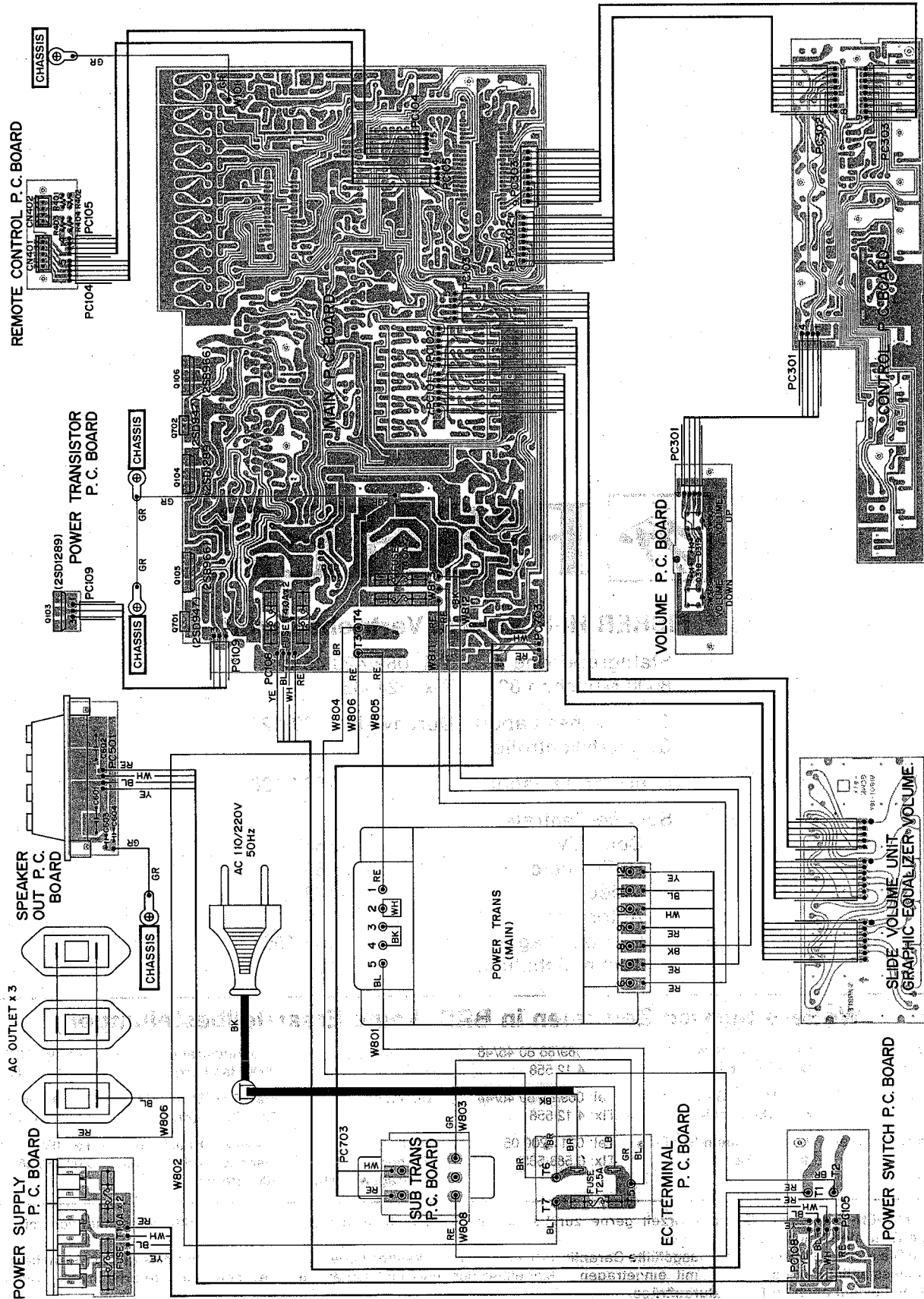



FISHER

FISHER Hi-Fi Europa Vertriebs GmbH

Stahlgruberring 4 Tel: 089/420 45-0
8000 München 82 Tlx: 524033

Technisches Labor/ Durchwahl -120/121
Qualitätskontrolle

Funkstörmeßlabor -127/128

Service-Zentrale

Color TV -166
Hi-Fi/Audio -168
Video -172
Autoradio -170
Ersatzteillager -155/156
Techn. Schulung -174

Weitere Service-Zentralen in BRD (keine Ersatzteilbestellungen)

Offenbach/ Frankfurt	Frankfurter Straße 121 6050 Offenbach	Tel: 069/88 80 45/48 Tlx: 4 12 558	Hamburg	Spaldingstraße 1 2000 Hamburg	Tel: 040/23 12 23/24 Tlx: 2 173 839
Military	Frankfurter Straße 121 6050 Offenbach	Tel: 069/88 80 45/48 Tlx: 4 12 558	Ditzingen	Max-Eyth-Straße 11 7257 Ditzingen	Tel: 07156/50 88 Tlx: 7 245 278
Düsseldorf-Erkrath	Albert-Einstein-Straße 8 4006 Erkrath 1	Tel: 0211/200 05-0 Tlx: 8 588 563	Berlin (Fisher Vertragswerkstatt)	Drewitz & Kaulbach Eisenacher Straße 53 1000 Berlin 62	Tel: 030/781 20 01 Tlx: 186 460

Unser FISHER-Team steht Ihnen jederzeit gerne zur Verfügung. Ersatzteilbestellungen wickeln Sie bitte ausschließlich mit unserer Service-Zentrale München ab.

Senden Sie uns im Garantiefall die ausgefüllte Garantiekarte ein. Bei unverkauften Lagergeräten des Fachhandels gilt als Garantienachweis eine eidesstattliche Versicherung mit eingetragener Modellbezeichnung und Geräte-Nummer oder ein Liefernachweis. Die gleiche Regelung besteht auch für Reparaturaufträge.

Bitte geben Sie unbedingt die Ersatzteil-Nummer und die Modellbezeichnung an.

Sie sparen so wertvolle Zeit. Vielen Dank.