

SERVICE MANUAL



FISHER

CA-35

**Integrated
Stereo Amplifier
(EUROPE)**

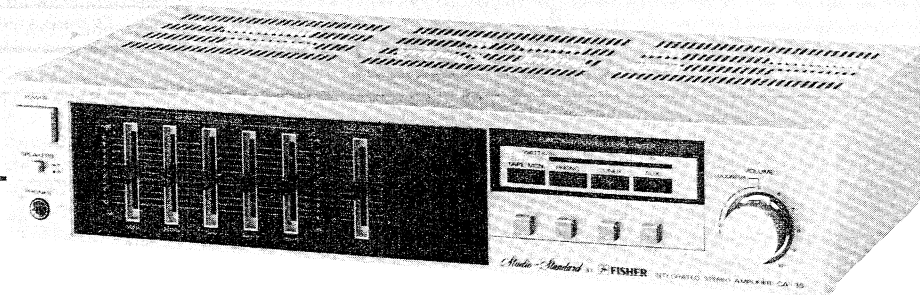

The first name in high fidelity

CONTENTS

Functional Block Diagram	2
Specifications	3
Disassembly Instructions	4
Recommended Test Equipments	5
Harmonic Distortion Test	5
Cabinet & Chassis Exploded View	6
Parts List	7
Connecting Diagram	8
IC Equivalent Circuit & Block Diagram	9
Parts List	10,11,12,13
Printed Circuit Board (Bottom View)	13,14,15,16
Point to Point Wiring Diagram	17,18
Schematic Diagram	19,20
Semiconductor Lead Identification	21

FUNCTIONAL BLOCK DIAGRAM

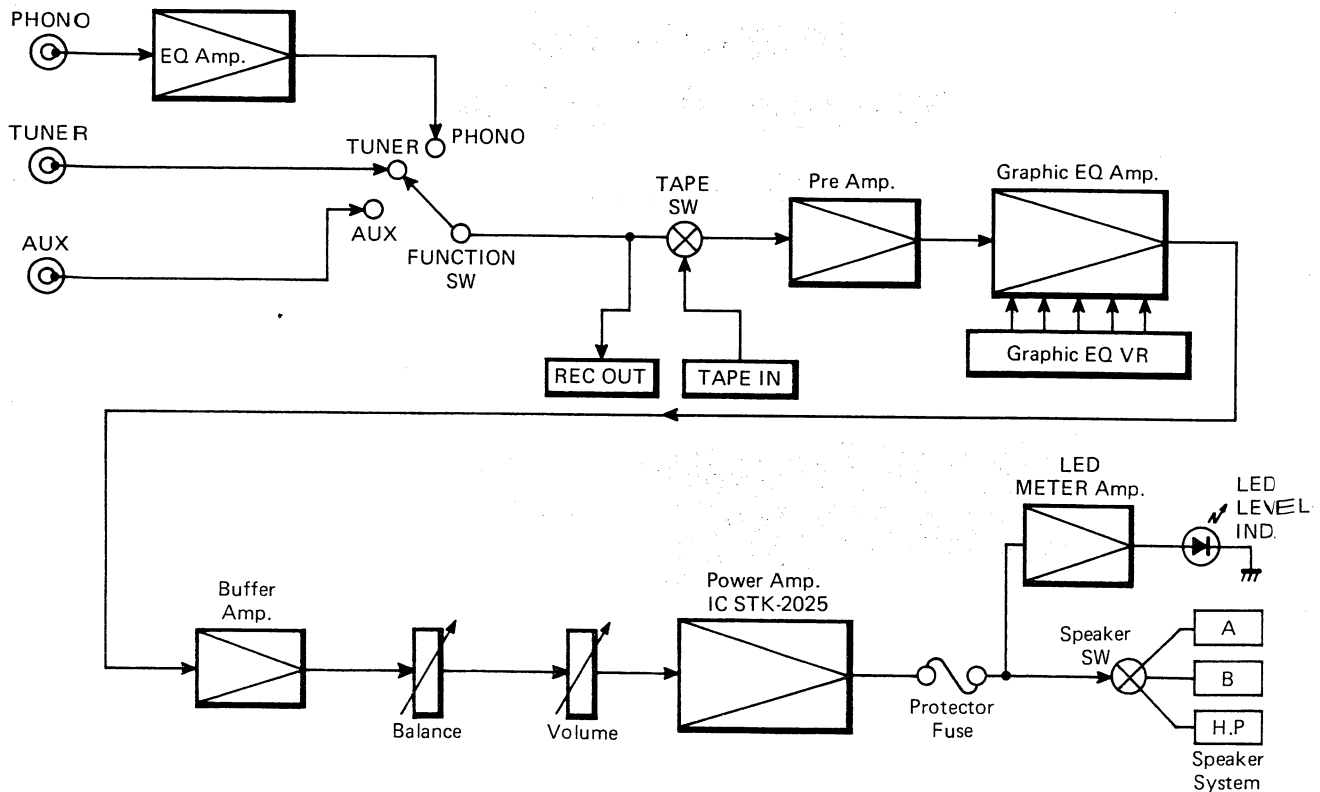

SPECIFICATIONS

AMPLIFIER	CA-35
POWER AMPLIFIER SECTION	
Minimum RMS sine wave power per channel within stated bandwidth at no more than stated distortion and with 8-ohm load	20 Watts
Power Bandwidth	40 Hz – 20 kHz
Total Harmonic Distortion	0.9 %
I.M. Distortion	0.9 %
Speaker Damping	>20
PREAMPLIFIER SECTION	
Frequency Response	
Phono (RIAA)	±0.5 dB
Aux (20 Hz – 20 kHz)	±0.5 dB
Input Sensitivity and Impedance	
Phono	2.5 mV/50 kΩ
Tape Monitor	150 mV/60 kΩ
Tuner/Auxiliary	150 mV/60 kΩ
Phono Max. Input Capability	
Phono	150 mV
Graphic Equalizer	
50 Hz	±10 dB
250 Hz	±10 dB
1 kHz	±10 dB
4.5 kHz	±10 dB
15 kHz	±10 dB
Hum and Noise (DIN)	
Phono	63 dB
Tape Monitor	85 dB
Tuner/Auxiliary	85 dB
GENERAL	
Power Requirements (50 Hz)	220 V AC
Power Consumption	120 W
AC Outlets	2
Dimensions (W x D x H)	400 x 215 x 80 mm
Weight (approx.)	3.9 kg

Because its products are subject to continuous improvement, Fisher Corporation reserves the right to modify product designs and specifications without notice and without incurring any obligation.

DISASSEMBLY INSTRUCTIONS

A. REMOVAL OF DECORATIVE PANEL

- Detach Cover by removing five screws.
- Pull out VOLUME knob.
- When Decorative Panel is removed from Chassis, the screw tightened through the Top and Bottom can be removed after the screw (A), as shown in Figs. 1 and 2, has been removed.

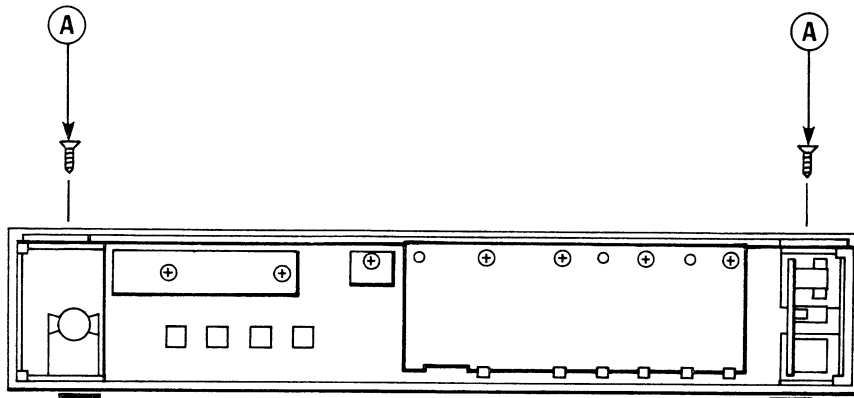

(FRONT PANEL REAR VIEW)

Fig. 1

B. REPAIR AND ADJUSTMENT OF PRINTED CIRCUIT BOARD

- The removal of Cabinet Bottom Plate (B), will give an access to the repair or adjustment work of Printed Circuit Board.

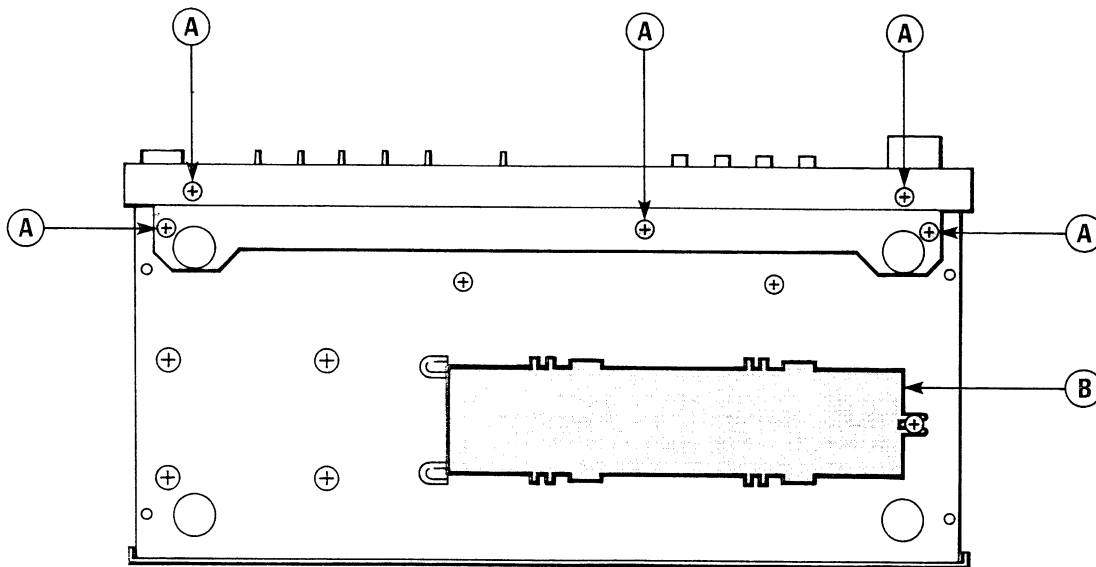

(BOTTOM VIEW)

Fig. 2

RECOMMENDED TEST EQUIPMENTS

The following test equipments are recommended to completely test and align the Amplifier:

- Line Voltage Isolation Transformer
- AC DC Multimeter.
- Accurately Calibrated AC Voltmeter.
- Oscilloscope (Flat to 100 kHz Minimum)
- Low-Distortion Audio Sine-Wave Generator
- Harmonic Distortion Analyzer
- Two (2) Load Resistors 8-ohms, 250 Watts (Minimum Rating)

HARMONIC DISTORTION TEST

CAUTION: Limit the following tests to no more than ten minutes each. Use 8-ohm resistors, with a minimum power rating of 250 watts when connecting a load across the SPEAKERS terminal.

CONTROL SETTINGS:

Unplug the AC power cord and set the front panel controls and follows:

- GRAPHIC EQUALIZER and BALANCE controls to center positions.
- POWER switch to OFF
- SPEAKERS switch to SYSTEM-B
- FUNCTION switch to AUX
- TAPE MONITOR switch to SOURCE
- VOLUME control to MINIMUM position
- LEFT CHANNEL DRIVEN

ONE CHANNEL DRIVEN:

- 1) Connect a low distortion audio generator to LEFT AUX IN jack. Set generator frequency to 1 kHz and output to minimum.
- 2) Connect an 8-ohm load resistor between SPEAKERS SYSTEM-A LEFT and COM terminals. Connect a Harmonic Distortion Analyzer and an AC VTVM in parallel across the 8-ohm load.
- 3) Connect the AC power cord and set SPEAKERS switch to SYSTEM-A. Turn VOLUME control to MAX.
- 4) Increase generator output for 20Watts RMS (12.6 volts across the 8-ohm load). Harmonic Distortion Analyzer should measure 0.9 % distortion or less.
- 5) Repeat steps 1 through 4 for RIGHT CHANNEL.

BOTH CHANNELS DRIVEN

Connect 8-ohm load resistors across LEFT and RIGHT SPEAKERS SYSTEM-A terminals. Adjust generator output and "BALANCE" control for 20 Watts at Left and Right Channels (12.6 volts across the 8-ohm loads). Harmonic Distortion Analyzer should measure 0.9 % distortion or less at each channel.

CAUTION: This precision high-fidelity instrument should be serviced only by qualified personnel, trained in the repair of transistor equipment and printed circuitry.

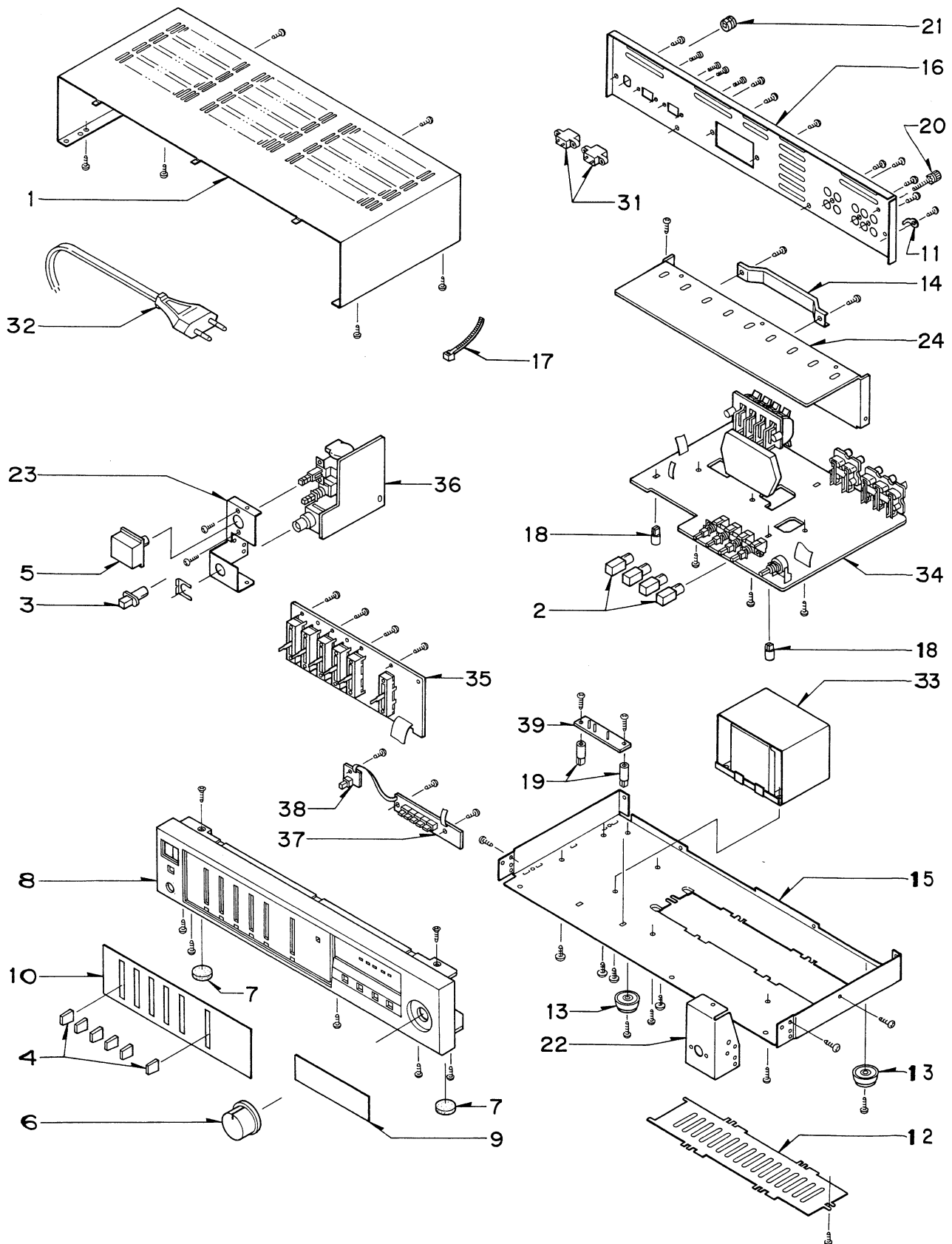

CABINET & CHASSIS EXPLODED VIEW



PARTS LIST

Ref. No.	Part No.	Description	Q'ty	Ref. No.	Part No.	Description	Q'ty
PACKING PARTS LIST				14	131 2 3101 71300	Metal Mount IC	1
	3 9415 10300	Bag Polyethylene	1	15	131 2 3301 28900	Chassis	1
131	6 1169 03120	Box Corrugate-EXP	1	16	131 2 3306 37409	Panel Rear	1
131	6 2119 02131	Bag Polyethylene-EXP	1	17	131 2 3608 12700	Cramp Wire	1
131	6 3069 16840	Patching Sheet	1	18	131 2 3614 20300	Mount P.C.B.	2
141	6 1449 88300	Pad (Left)	1	19	131 2 3614 21800	Mount P.C.B.	2
141	6 1449 88400	Pad (Right)	1	20	131 2 4201 17800	Screw Ground	1
ACCESSORIES PARTS LIST				21	131 2 6111 14200	Bushing	1
131	6 2719 10801	Bag Fan	1	22	141 2 3519 66600	Metal Mount (Right)	1
131	6 4519 15700	Guarantee Cert	1	23	141 2 3519 66700	Metal Mount (Left)	1
142	6 4119 31705	Explanatory Booklet	1	24	141 2 3689 10900	Plate Heat Sink	1
CABINET & CHASSIS PARTS LIST				ELECTRICAL PARTS LIST			
1	131 2 1410 27401	Cover	1	31	△ 4 2359 74032	2P Socket (With Nut)	2
2	131 2 1601 64106	Knob (Function SW.)	4	32	△ 4 2432 00140	Power Cord	1
3	131 2 1601 69600	Knob (Speaker Select SW.)	1	33	△ 4 2519 73860	Power Trans	1
4	131 2 1601 71001	Knob (Graphic EQ./ Balance VR.)	6	34	141 0 1939 00670	Main P.C.B.Assy	1
5	131 2 1601 86200	Knob (Power SW.)	1	35	141 0 1939 00680	Graphic EQ. P.C.B.Assy	1
6	131 2 1601 87100	Knob (Volume)	1	36	141 0 1939 00690	Power SW. P.C.B.Assy	1
7	131 2 1801 16200	Leg (Front Panel)	2	37	141 0 1939 00700	Level Meter P.C.B.Assy	1
8	141 2 1119 92700	Cabinet Front	1	38	141 0 1939 00710	Power IND. P.C.B.Assy	1
9	141 2 1449 56401	Plate Decorate	1	39	141 0 1939 00720	Voltage SW. P.C.B.Assy	1
10	141 2 1449 56500	Plate Decorate	1	NOTES:			
11	4 2379 21520	Terminal Lug	1	1. Parts order must contain Model Number, Part Number and Description.			
12	131 2 1410 27600	Cover	1	2. Ordering quantity of screws and resistors must be multiple of 10 pcs.			
13	131 2 1801 12900	Leg (Rear Panel)	2				

PRODUCT SAFETY NOTICE

Each precaution in this manual should be followed during servicing. Components identified with the IEC symbol  in the parts list and the schematic diagram designate components in which safety can be of special significance. When replacing a component identified with , use only the replacement parts designated, or parts with the same ratings of resistance, wattage or voltage that are designated in the parts list in this manual.

Leakage-current or resistance measurements must be made to determine that exposed parts are acceptably insulated from the supply circuit before returning the product to the customer.

IMPORTANT NOTE

The amplifier has been factory-adjusted for operation on 220 V AC. The voltage can be changed for operation on 110 V AC by making the following changes on the amplifier inside.

- Remove the AC plug from the wall outlet.
- Remove the screws securing the cover.
- Disconnect gray lead from Voltage SW. P.C.Board No. 10 terminal, and then connect it to Power SW. P.C.Board No. 3 terminal.
- Disconnect black lead from Voltage SW. P.C.Board No. 11 terminal, and then connect it to No. 10 terminal.

The amplifier is now ready 110 V operation. DO NOT attempt to operate the amplifier on 220 V. Damage will result!

CONNECTING DIAGRAM

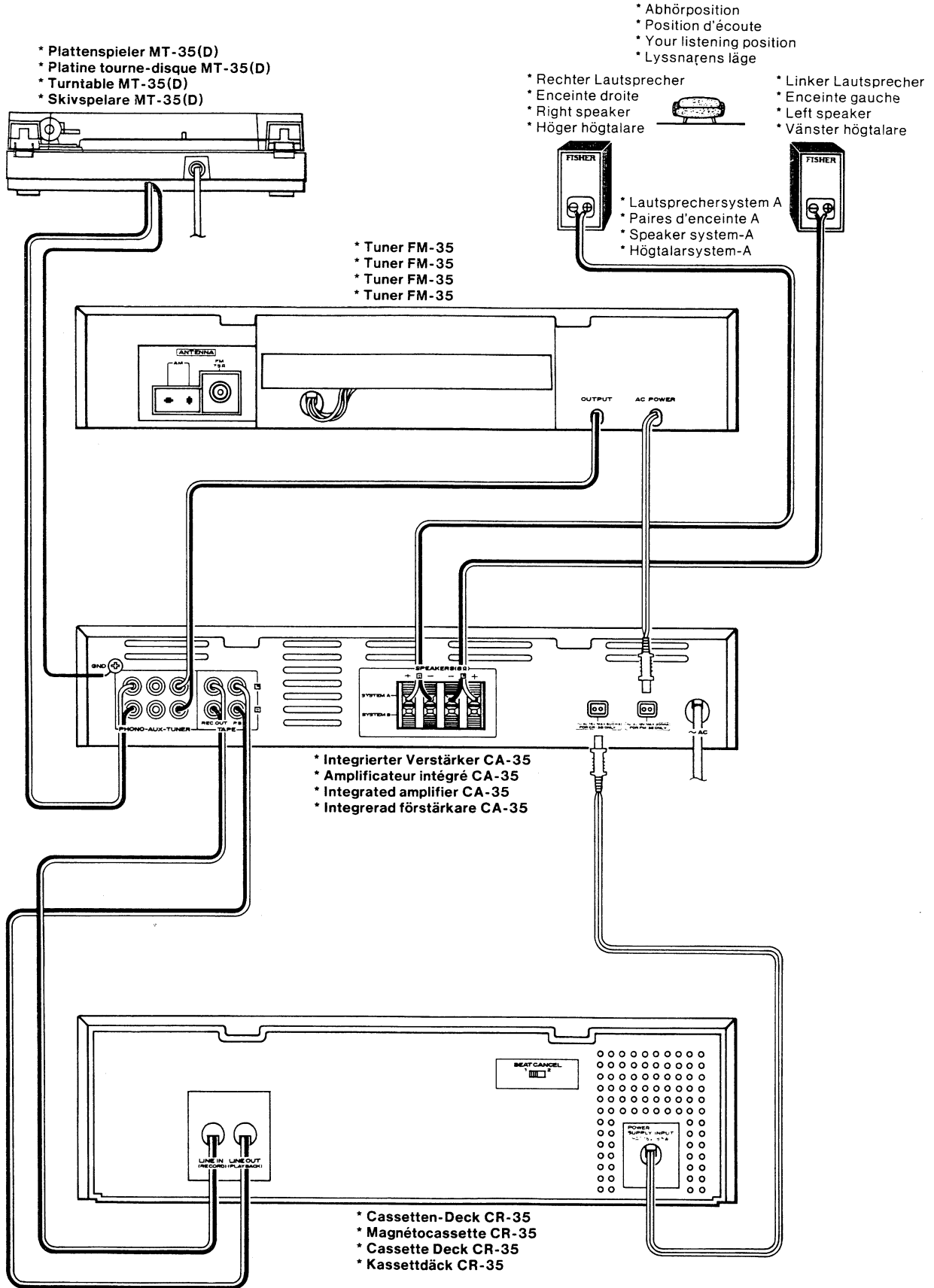

IC EQUIVALENT CIRCUIT & BLOCK DIAGRAM

EQ AMP IC NJM072

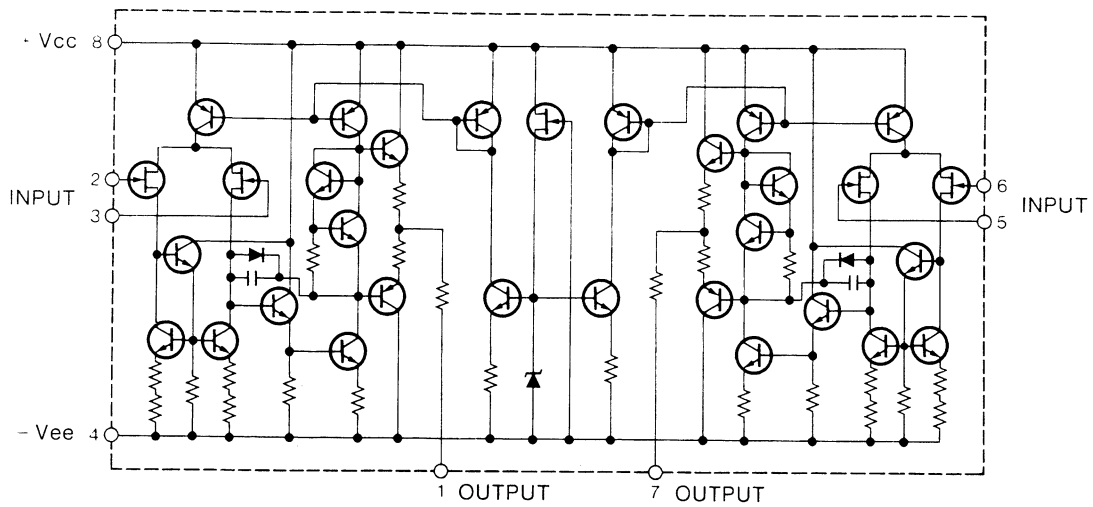

L.E.D. LEVEL METER IC LB1423

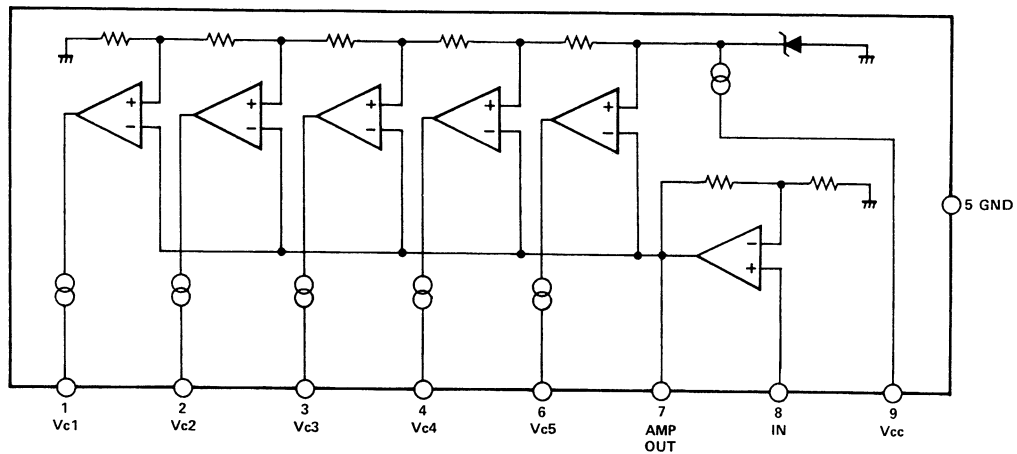

POWER AMP IC STK2025

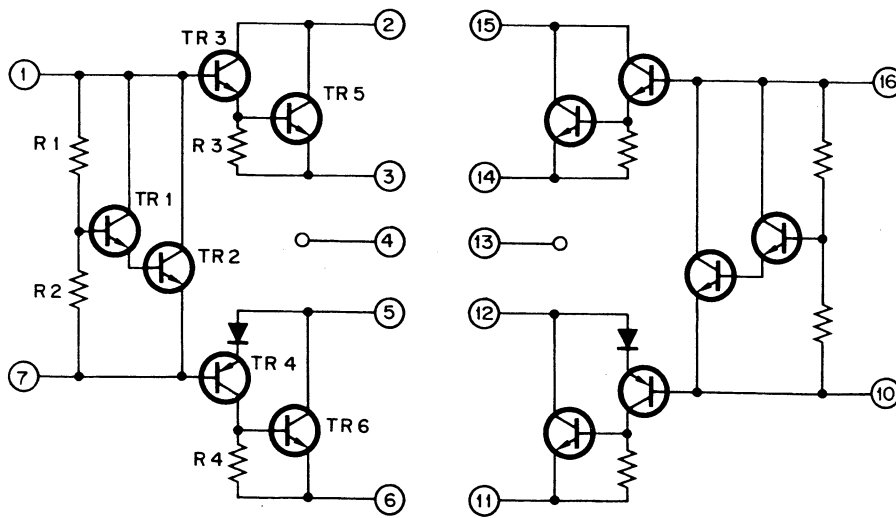

PARTS LIST (Continued)

Ref. No.	Part No.	Description	Q'ty	Ref. No.	Part No.	Description	Q'ty
Q211	203 5 4921 01260	TR, 2SD 1012 F,G	1	R256	RD2 2 2161 JH000	Carbon	2.2kΩ 1/6W ±5% 1
Q301	203 5 7330 61251	TR, 2SD 612K E,F	1	R258	RD2 2 2251 JM000	Carbon	2.2kΩ 1/4W ±5% 1
Q302	203 5 6840 56050	TR, 2SB 560 E,F	1	R259	RD1 5 3251 JM000	Carbon	15kΩ 1/4W ±5% 1
Q401	203 5 7230 60860	TR, 2SA 608 F,G	1	R301	RF3 9 0501 JZ000	Mold	39Ω 1/2W ±5% 1
Q402	203 5 7230 60860	TR, 2SA 608 F,G	1	R302	RD2 7 1251 JS000	Carbon	270Ω 1/4W ±5% 1
RESISTORS				R303	RD1 0 2251 JM000	Carbon	1kΩ 1/4W ±5% 1
R101	RD1 2 4161 JH000	Carbon	120kΩ 1/6W ±5% 1	R304	RD1 0 2161 JH000	Carbon	1kΩ 1/6W ±5% 1
R102	RD1 0 4161 JH000	Carbon	100kΩ 1/6W ±5% 1	R305	RF1 0 1251 JK000	Mold	100Ω 1/4W ±5% 1
R103	RD2 7 1161 JH000	Carbon	270Ω 1/6W ±5% 1	R306	RF1 0 1251 JK000	Mold	100Ω 1/4W ±5% 1
R104	RD2 2 4161 JH000	Carbon	220kΩ 1/6W ±5% 1	R307	RF1 0 1251 JH000	Mold	100Ω 1/4W ±5% 1
R105	RD1 5 3161 JH000	Carbon	15kΩ 1/6W ±5% 1	R308	RF1 0 1251 JH000	Mold	100Ω 1/4W ±5% 1
R106	RD1 0 4161 JH000	Carbon	100kΩ 1/6W ±5% 1	R309	RF1 0 1251 JH000	Mold	100Ω 1/4W ±5% 1
R107	RD5 6 2251 JM000	Carbon	5.6kΩ 1/4W ±5% 1	R401	RD2 7 3161 JH000	Carbon	27kΩ 1/6W ±5% 1
R134	RD3 3 3161 JH000	Carbon	33kΩ 1/6W ±5% 1	R402	RD1 0 2161 JH000	Carbon	1kΩ 1/6W ±5% 1
R135	RD1 5 4251 JM000	Carbon	150kΩ 1/4W ±5% 1	R403	RD3 3 3251 JM000	Carbon	33kΩ 1/4W ±5% 1
R136	RD5 6 1251 JM000	Carbon	560Ω 1/4W ±5% 1	R404	RD5 6 2161 JH000	Carbon	5.6kΩ 1/6W ±5% 1
R137	RD6 8 2251 JM000	Carbon	6.8kΩ 1/4W ±5% 1	R405	RD1 0 2161 JH000	Carbon	1kΩ 1/6W ±5% 1
R138	RD5 6 1251 JM000	Carbon	560Ω 1/4W ±5% 1	R406	RD3 3 3161 JH000	Carbon	33kΩ 1/6W ±5% 1
R139	RD6 8 2251 JM000	Carbon	6.8kΩ 1/4W ±5% 1	R407	RD1 0 3251 JM000	Carbon	10kΩ 1/4W ±5% 1
R140	RD6 8 2161 JH000	Carbon	6.8kΩ 1/6W ±5% 1	R408	RD1 2 1251 JM000	Carbon	120Ω 1/4W ±5% 1
R141	RD1 0 1251 JM000	Carbon	100Ω 1/4W ±5% 1	R409	RD2 7 2251 JM000	Carbon	2.7kΩ 1/4W ±5% 1
R142	RD6 8 3251 JM000	Carbon	68kΩ 1/4W ±5% 1	GRAPHIC EQ. P.C.B. Assy			
R143	RD1 5 2161 JH000	Carbon	1.5kΩ 1/6W ±5% 1	141 0 1939 00680	Graphic EQ. P.C.B. Assy		1
R144	RD2 2 3251 JM000	Carbon	22kΩ 1/4W ±5% 1	VR401	4 2222 03050	VR Slide 250kΩ-SW x2	1
R145	RD1 0 1251 JM000	Carbon	100Ω 1/4W ±5% 1	VR402	4 2222 03050	VR Slide 250kΩ-SW x2	1
R146	RF1 0 1251 JK000	Mold	100Ω 1/4W ±5% 1	VR403	4 2222 03050	VR Slide 250kΩ-SW x2	1
R147	RF8 2 0251 JK000	Mold	82Ω 1/4W ±5% 1	VR404	4 2222 03050	VR Slide 250kΩ-SW x2	1
R148	RH1 0 0501 JZ000	Metal	10Ω 1/2W ±5% 1	VR405	4 2222 03050	VR Slide 250kΩ-SW x2	1
R149	RD1 0 1251 JM000	Carbon	100Ω 1/4W ±5% 1	VR406	4 2222 02820	VR Slide 200kΩ-G x2	1
R152	RD5 6 1161 JH000	Carbon	560Ω 1/6W ±5% 1	CAPACITORS			
R153	RD1 5 3161 JH000	Carbon	15kΩ 1/6W ±5% 1	C107	CD1 0 5500 0001V	Electrolytic	1μF 50V 1
R154	RD1 0 3251 JM000	Carbon	10kΩ 1/4W ±5% 1	C108	CC2 2 1500 KD00C	Ceramic	220pF 50V ±10% 1
R155	RD2 2 2161 JH000	Carbon	2.2kΩ 1/6W ±5% 1	C109	CC1 0 0500 KD00C	Ceramic	10pF 50V ±10% 1
R156	RD2 2 2161 JH000	Carbon	2.2kΩ 1/6W ±5% 1	C110	CD2 2 6250 0001V	Electrolytic	22μF 25V 1
R158	RD2 2 2251 JM000	Carbon	2.2kΩ 1/4W ±5% 1	C111	CD1 0 6500 0001V	Electrolytic	10μF 50V 1
R159	RD1 5 3251 JM000	Carbon	15kΩ 1/4W ±5% 1	C112	CD3 3 5500 0001V	Electrolytic	3.3μF 50V 1
R201	RD1 2 4161 JH000	Carbon	120kΩ 1/6W ±5% 1	C113	CM1 8 3500 K00SV	Mylar	0.018μF 50V ±10% 1
R202	RD1 0 4161 JH000	Carbon	100kΩ 1/6W ±5% 1	C114	CD3 3 4500 0001V	Electrolytic	0.33μF 50V 1
R203	RD2 7 1161 JH000	Carbon	270Ω 1/6W ±5% 1	C115	CM8 2 2500 K00SV	Mylar	0.0082μF 50V ±10% 1
R204	RD2 2 4161 JH000	Carbon	220kΩ 1/6W ±5% 1	C116	CM8 2 3500 J00TV	Mylar	0.082μF 50V ±5% 1
R205	RD1 5 3161 JH000	Carbon	15kΩ 1/6W ±5% 1	C117	CM4 7 2500 K00SV	Mylar	0.0047μF 50V ±10% 1
R206	RD1 0 4161 JH000	Carbon	100kΩ 1/6W ±5% 1	C118	CM2 2 3500 K00SV	Mylar	0.022μF 50V ±10% 1
R207	RD5 6 2251 JM000	Carbon	5.6kΩ 1/4W ±5% 1	C119	CM1 2 2500 K00SV	Mylar	0.0012μF 50V ±10% 1
R234	RD3 3 3161 JH000	Carbon	33kΩ 1/6W ±5% 1	C120	CM4 7 2500 K00SV	Mylar	0.0047μF 50V ±10% 1
R235	RD1 5 4251 JM000	Carbon	150kΩ 1/4W ±5% 1	C121	CC6 8 1500 KE00C	Ceramic	680pF 50V ±10% 1
R236	RD5 6 1251 JM000	Carbon	560Ω 1/4W ±5% 1	C144	CC2 2 1500 KD00R	Ceramic	220pF 50V ±10% 1
R237	RD6 8 2251 JM000	Carbon	6.8kΩ 1/4W ±5% 1	C145	CC2 2 1500 KD00R	Ceramic	220pF 50V ±10% 1
R238	RD5 6 1251 JM000	Carbon	560Ω 1/4W ±5% 1	C207	CD1 0 5500 0001V	Electrolytic	1μF 50V 1
R239	RD6 8 2251 JM000	Carbon	6.8kΩ 1/4W ±5% 1	C208	CC2 2 1500 KD00C	Ceramic	220pF 50V ±10% 1
R240	RD6 8 2161 JH000	Carbon	6.8kΩ 1/6W ±5% 1	C209	CC1 0 0500 KD00C	Ceramic	10pF 50V ±10% 1
R241	RD1 0 1251 JM000	Carbon	100Ω 1/4W ±5% 1	C210	CD2 2 6250 0001V	Electrolytic	22μF 25V 1
R242	RD6 8 3251 JM000	Carbon	68kΩ 1/4W ±5% 1	C211	CD1 0 6500 0001V	Electrolytic	10μF 50V 1
R243	RD1 5 2251 JM000	Carbon	1.5kΩ 1/4W ±5% 1	C212	CD3 3 5500 0001V	Electrolytic	3.3μF 50V 1
R244	RD2 2 3251 JM000	Carbon	22kΩ 1/4W ±5% 1	C213	CM1 8 3500 K00SV	Mylar	0.018μF 50V ±10% 1
R245	RD1 0 1251 JM000	Carbon	100Ω 1/4W ±5% 1	C214	CD3 3 4500 0001V	Electrolytic	0.33μF 50V 1
R246	RF1 0 1251 JK000	Mold	100Ω 1/4W ±5% 1	C215	CM8 2 2500 K00SV	Mylar	0.0082μF 50V ±10% 1
R247	RF8 2 0251 JK000	Mold	82Ω 1/4W ±5% 1	C216	CM8 2 3500 J00TV	Mylar	0.082μF 50V ±5% 1
R248	RH1 0 0501 JZ000	Metal	10Ω 1/2W ±5% 1	C217	CM4 7 2500 K00SV	Mylar	0.0047μF 50V ±10% 1
R249	RD1 0 1251 JM000	Carbon	100Ω 1/4W ±5% 1	C218	CM2 2 3500 K00SV	Mylar	0.022μF 50V ±10% 1
R252	RD5 6 1161 JH000	Carbon	560Ω 1/6W ±5% 1	C219	CM1 2 2500 K00SV	Mylar	0.0012μF 50V ±10% 1
R253	RD1 5 3161 JH000	Carbon	15kΩ 1/6W ±5% 1	C220	CM4 7 2500 K00SV	Mylar	0.0047μF 50V ±10% 1
R254	RD1 0 3251 JM000	Carbon	10kΩ 1/4W ±5% 1				
R255	RD2 2 2161 JH000	Carbon	2.2kΩ 1/6W ±5% 1				

PARTS LIST (Continued)

Ref. No.	Part No.	Description	Q'ty	Ref. No.	Part No.	Description	Q'ty		
C221	CC6 8 1500 KE00C	Ceramic	680pF 50V ±10%	1	R225	RD1 5 3161 JH000 Carbon	15kΩ 1/6W ±5%	1	
C244	CC2 2 1500 KD00C	Ceramic	220pF 50V ±10%	1	R226	RD3 9 1251 JM000 Carbon	390Ω 1/4W ±5%	1	
C245	CC2 2 1500 KD00C	Ceramic	220pF 50V ±10%	1	R227	RD1 5 2161 JH000 Carbon	1.5kΩ 1/6W ±5%	1	
C311	CD4 7 6250 0001V	Electrolytic	47μF 25V	1	R228	RD3 3 3161 JH000 Carbon	33kΩ 1/6W ±5%	1	
C312	CD4 7 6250 0001V	Electrolytic	47μF 25V	1	R229	RD1 5 3161 JH000 Carbon	15kΩ 1/6W ±5%	1	
SEMICONDUCTORS					R230	RD3 9 1251 JM000 Carbon	390Ω 1/4W ±5%	1	
IC402	IJJ - NJM072D-E	IC, NJM 072 D,E		1	R231	RD1 5 2161 JH000 Carbon	1.5kΩ 1/6W ±5%	1	
Q101	203 5 5000 53660	TR, 2SC 536 F,G		1	R232	RD2 2 3161 JH000 Carbon	22kΩ 1/6W ±5%	1	
Q102	203 5 5000 53660	TR, 2SC 536 F,G		1	R233	RD1 5 3161 JH000 Carbon	15kΩ 1/6W ±5%	1	
Q103	203 5 5000 53660	TR, 2SC 536 F,G		1	R257	RD2 2 2161 JH000 Carbon	2.2kΩ 1/6W ±5%	1	
Q104	203 5 5000 53660	TR, 2SC 536 F,G		1					
Q105	203 5 5000 53660	TR, 2SC 536 F,G		1	POWER SW. P.C.B. Assy				
Q201	203 5 5000 53660	TR, 2SC 536 F,G		1	141	0 1939 00690	Power SW. P.C.B. Assy	1	
Q202	203 5 5000 53660	TR, 2SC 536 F,G		1	△	4 2312 05710	SW. Push Power	1	
Q203	203 5 5000 53660	TR, 2SC 536 F,G		1		4 2312 05820	SW. Push 1 Key	1	
Q204	203 5 5000 53660	TR, 2SC 536 F,G		1		4 2352 01170	Jack 7P	1	
Q205	203 5 5000 53660	TR, 2SC 536 F,G		1		4 2372 00830	EC Terminal 1P	2	
						111 2 6220 11100	Wire Wrap Terminal	2	
						131 2 6114 00200	Cover Safety	1	
RESISTORS					CAPACITOR				
R108	RD1 2 4251 JM000	Carbon	120kΩ 1/4W ±5%	1	C316	△ 4 2239 70970	Ceramic	0.01μF 400V	1
R109	RD1 0 4251 JM000	Carbon	100kΩ 1/4W ±5%	1	RESISTORS				
R110	RD4 7 2161 JH000	Carbon	4.7kΩ 1/6W ±5%	1	R150	RH3 3 1501 JZ000	Metal	330Ω 1/2W ±5%	1
R111	RD1 0 4161 JH000	Carbon	100kΩ 1/6W ±5%	1	R151	RD2 7 1251 JM000	Carbon	270Ω 1/4W ±5%	1
R112	RD4 7 2161 JH000	Carbon	4.7kΩ 1/6W ±5%	1	R250	RH3 3 1501 JZ000	Metal	330Ω 1/2W ±5%	1
R113	RD3 3 2161 JH000	Carbon	3.3kΩ 1/6W ±5%	1	R251	RD2 7 1251 JM000	Carbon	270Ω 1/4W ±5%	1
R114	RD3 9 1161 JH000	Carbon	390Ω 1/6W ±5%	1					
R115	RD1 2 2161 JH000	Carbon	1.2kΩ 1/6W ±5%	1					
R116	RD1 2 4161 JH000	Carbon	120kΩ 1/6W ±5%	1					
R117	RD1 5 3161 JH000	Carbon	15kΩ 1/6W ±5%	1					
R118	RD3 9 1161 JH000	Carbon	390Ω 1/6W ±5%	1					
R119	RD1 2 2161 JH000	Carbon	1.2kΩ 1/6W ±5%	1					
R120	RD1 0 4161 JH000	Carbon	100kΩ 1/6W ±5%	1					
R121	RD1 5 3161 JH000	Carbon	15kΩ 1/6W ±5%	1					
R122	RD3 9 1161 JH000	Carbon	390Ω 1/6W ±5%	1					
R123	RD1 5 2161 JH000	Carbon	1.5kΩ 1/6W ±5%	1					
R124	RD3 9 3161 JH000	Carbon	39kΩ 1/6W ±5%	1					
R125	RD1 5 3161 JH000	Carbon	15kΩ 1/6W ±5%	1					
R126	RD3 9 1161 JH000	Carbon	390Ω 1/6W ±5%	1					
R127	RD1 5 2161 JH000	Carbon	1.5kΩ 1/6W ±5%	1					
R128	RD3 3 3161 JH000	Carbon	33kΩ 1/6W ±5%	1					
R129	RD1 5 3161 JH000	Carbon	15kΩ 1/6W ±5%	1					
R130	RD3 9 1161 JH000	Carbon	390Ω 1/6W ±5%	1					
R131	RD1 5 2161 JH000	Carbon	1.5kΩ 1/6W ±5%	1					
R132	RD2 2 3161 JH000	Carbon	22kΩ 1/6W ±5%	1					
R133	RD1 5 3161 JH000	Carbon	15kΩ 1/6W ±5%	1					
R157	RD2 2 2161 JH000	Carbon	2.2kΩ 1/6W ±5%	1					
R208	RD1 2 4161 JH000	Carbon	120kΩ 1/6W ±5%	1					
R209	RD1 0 4161 JH000	Carbon	100kΩ 1/6W ±5%	1					
R210	RD4 7 2161 JH000	Carbon	4.7kΩ 1/6W ±5%	1					
R211	RD1 0 4161 JH000	Carbon	100kΩ 1/6W ±5%	1					
R212	RD4 7 2161 JH000	Carbon	4.7kΩ 1/6W ±5%	1					
R213	RD3 3 2161 JH000	Carbon	3.3kΩ 1/6W ±5%	1					
R214	RD3 9 1251 JM000	Carbon	390Ω 1/4W ±5%	1					
R215	RD1 2 2161 JH000	Carbon	1.2kΩ 1/6W ±5%	1					
R216	RD1 2 4161 JH000	Carbon	120kΩ 1/6W ±5%	1					
R217	RD1 5 3161 JH000	Carbon	15kΩ 1/6W ±5%	1					
R218	RD3 9 1251 JM000	Carbon	390Ω 1/4W ±5%	1					
R219	RD1 2 2161 JH000	Carbon	1.2kΩ 1/6W ±5%	1					
R220	RD1 0 4161 JH000	Carbon	100kΩ 1/6W ±5%	1					
R221	RD1 5 3161 JH000	Carbon	15kΩ 1/6W ±5%	1					
R222	RD3 9 1251 JM000	Carbon	390Ω 1/4W ±5%	1					
R223	RD1 5 2161 JH000	Carbon	1.5kΩ 1/6W ±5%	1					
R224	RD3 9 3161 JH000	Carbon	39kΩ 1/6W ±5%	1					

PARTS LIST (Continued)

Ref. No.	Part No.	Description	Q'ty	Ref. No.	Part No.	Description	Q'ty		
LEVEL METER P.C.B. Assy				POWER IND. P.C.B. Assy					
141	0 1939 00700	Level Meter P.C.B. Assy	1	141	0 1939 00710	Power IND. P.C.B. Assy	1		
131	2 4208 41800	Spacer	5	131	2 4208 41300	Spacer (LED)	1		
CAPACITOR				SEMICONDUCTOR					
C403	CD1 0 6250 0001V	Electrolytic	10 μ F 25V	1	D408	4 2029 72101	LED, GL 9 PR	1	
SEMICONDUCTORS				RESISTOR					
D403	D00 - SLP- 173B-	LED, SLP 173 B		1	R419	RD1 8 2251 JM000	Carbon	1.8k Ω 1/4W \pm 5%	1
D404	D00 - SLP- 173B-	LED, SLP 173 B		1					
D405	D00 - SLP- 173B-	LED, SLP 173 B		1					
D406	D00 - SLP- 173B-	LED, SLP 173 B		1					
D407	D00 - SLP- 173B-	LED, SLP 173 B		1					
IC404	206 5 2291 42310	IC, LB 1423 (LED-Drive)		1					
RESISTORS				NOTES:					
R415	RD2 2 A161 JH000	Carbon	2.2 Ω 1/6W \pm 5%	1	1. Parts order must contain Model Number, Part Number and Description.				
R416	RD2 2 A161 JH000	Carbon	2.2 Ω 1/6W \pm 5%	1	2. Ordering quantity of screws and resistors must be multiple of 10 pcs.				
R417	RD5 6 1161 JH000	Carbon	560 Ω 1/6W \pm 5%	1					
R418	RD1 0 3161 JH000	Carbon	10k Ω 1/6W \pm 5%	1					

GRAPHIC EQUALIZER P.C.BOARD (BOTTOM VIEW)

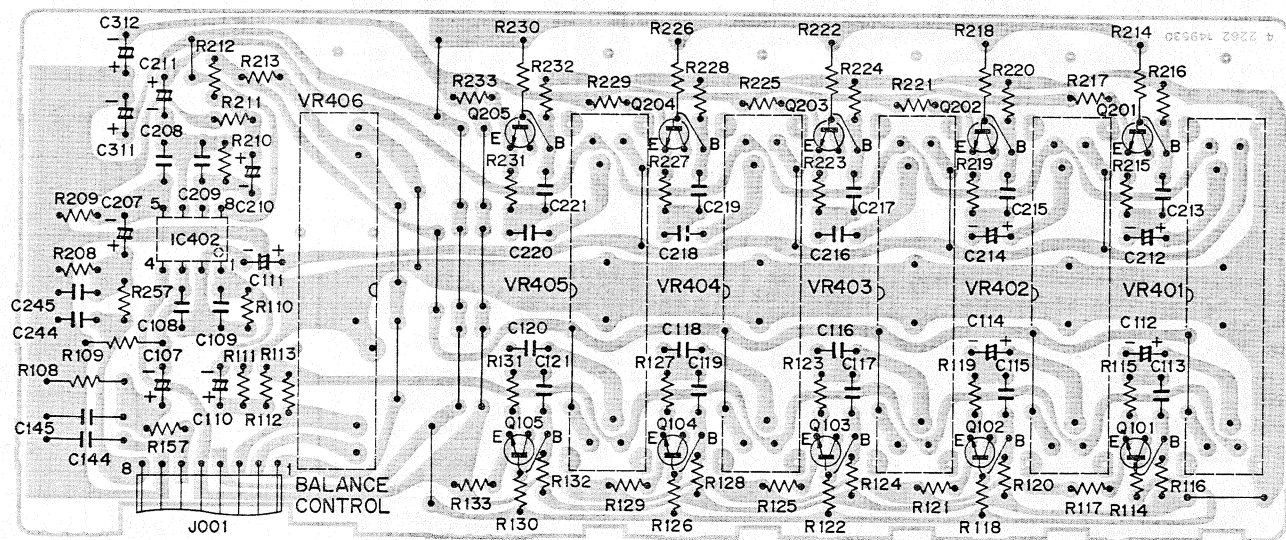

SYMBOL No.	DEVICE	1	2	3	4	5	6	7	8
IC402	NJM 072	0V	0V	0V	-14.7V	0V	0V	0V	15.2V

SYMBOL No.	DEVICE	B	C	E	SYMBOL No.	DEVICE	B	C	E
Q101,201	2SC 536	-0.4V	14.9V	-1.0V	Q104,204	2SC 536	-0.3V	14.9V	-0.7V
Q102,202	2SC 536	-0.4V	14.9V	-1.0V	Q105,205	2SC 536	-0.1V	14.9V	-0.7V
Q103,203	2SC 536	-0.3V	14.9V	-0.7V					

POWER SW. P.C.BOARD (BOTTOM VIEW)

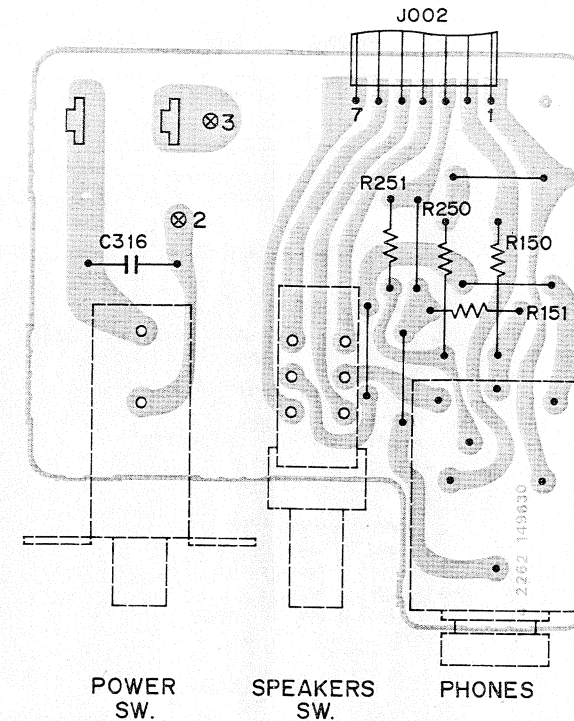

VOLTAGE SW. P.C.BOARD (BOTTOM VIEW)

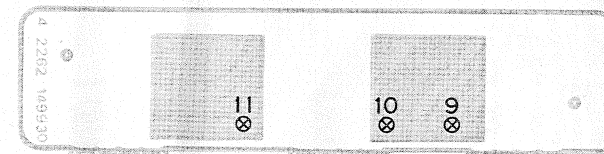

POWER IND. P.C.BOARD (BOTTOM VIEW)

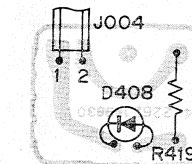

LEVEL METER P.C.BOARD (BOTTOM VIEW)

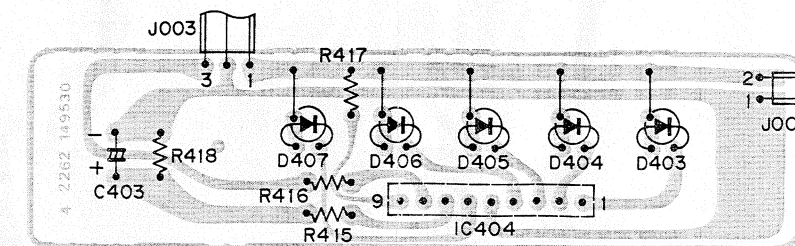

SYMBOL No.	DEVICE	1	2	3	4	5	6	7	8	9
IC404	LB 1423	13.7V	13.7V	13.7V	13.7V	0V	13.7V	-	-	12.4V

POINT TO POINT WIRING DIAGRAM

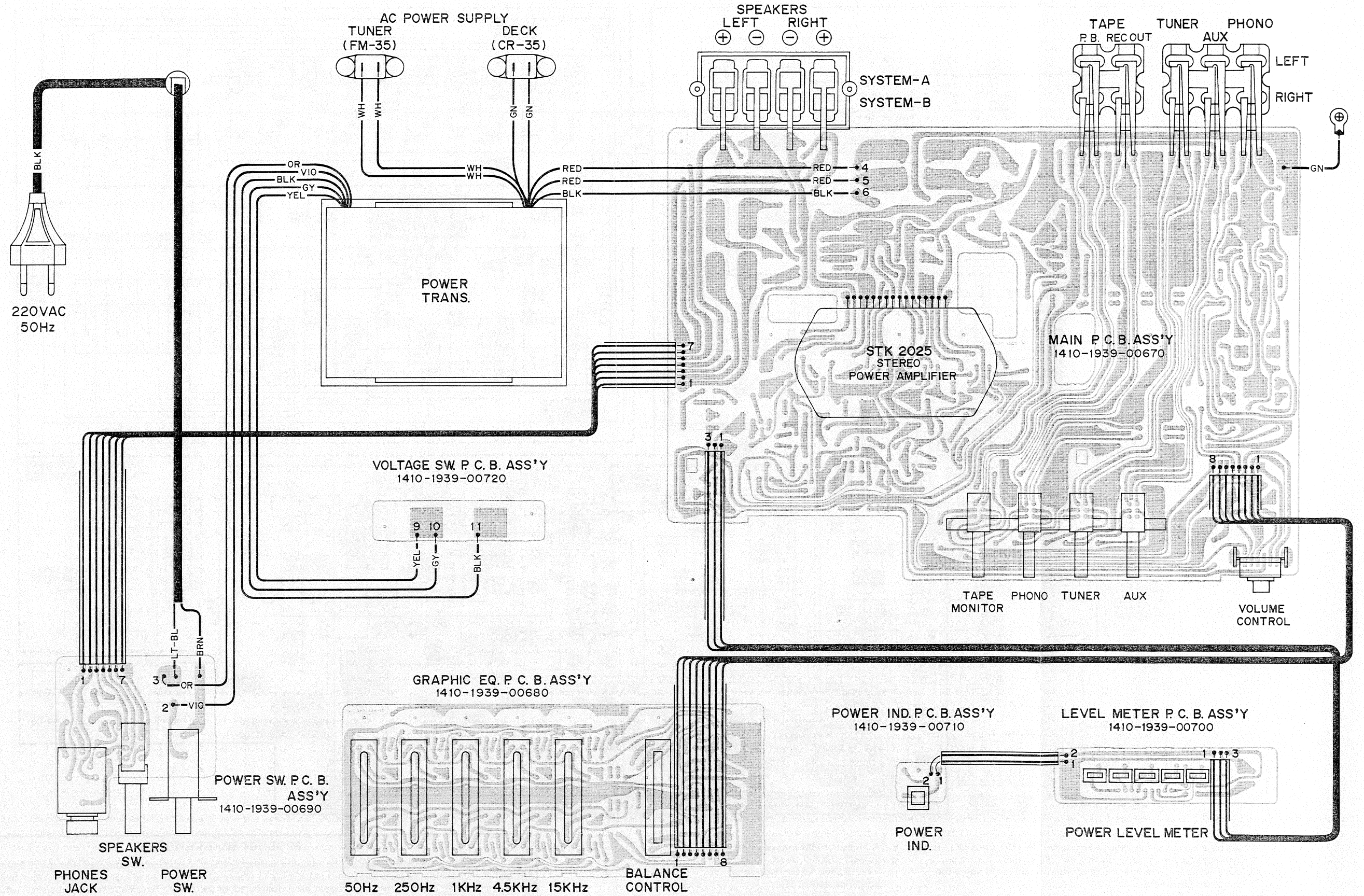

SCHEMATIC DIAGRAM

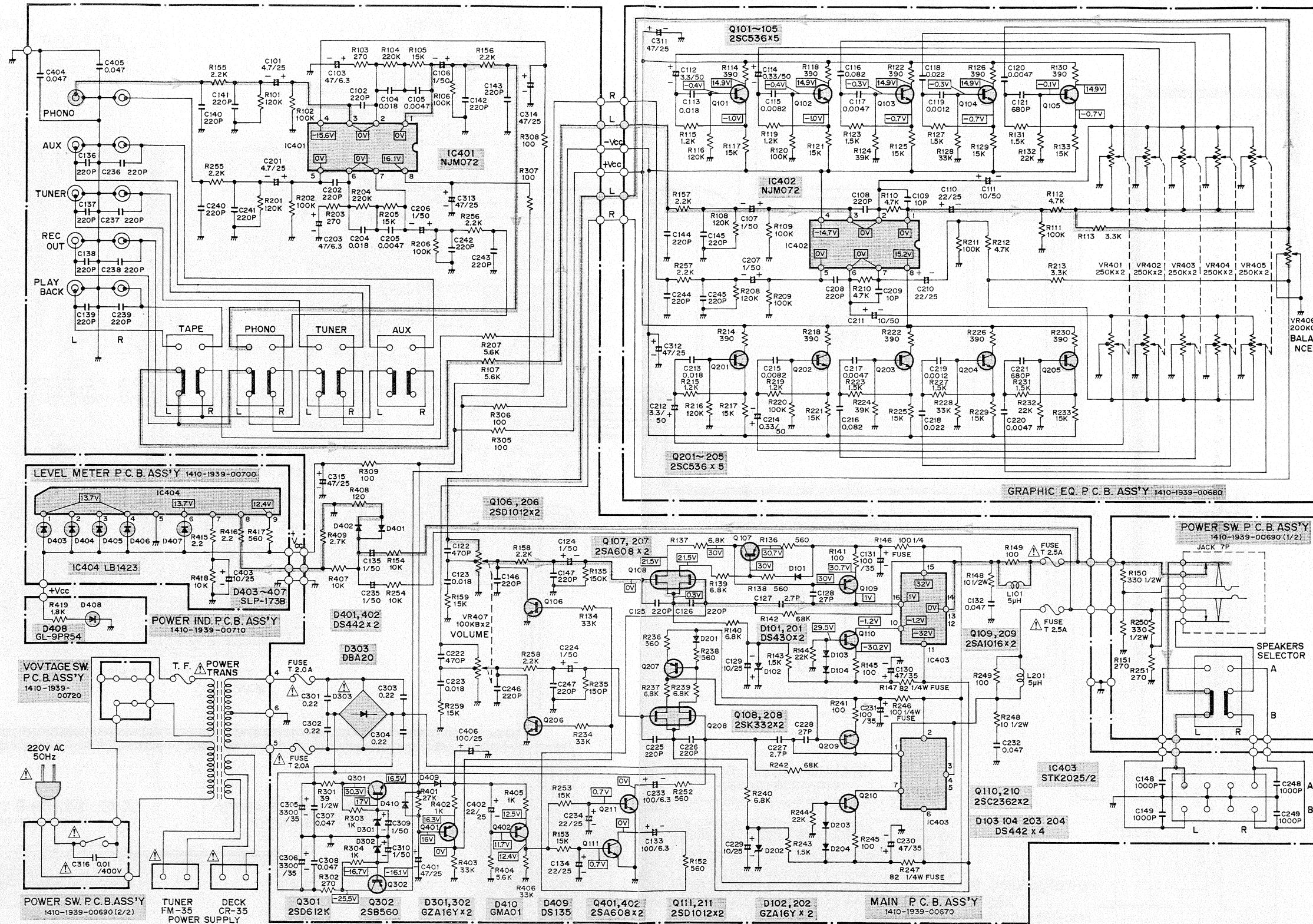

NOTES:

1. All resistors values are indicated in "ohm" (K=10³, M=10⁶).
 2. All capacitors values are indicated in "µF" (P=10⁻¹²).
 3. All voltages indicated on the schematics are measured under the following conditions.
 - a. Use a V.T.V.M.
 - b. All voltages ±10% with respect to chassis ground
 4. This is a basic schematic diagram.
 5. AC input at 220 volts 50 Hz
 6. FUNCTION SW: AUX
 7. Input Signal: 1 kHz (Sine-wave)
 8. Load Resistance: 8Ω
 9. Output: 2.5 W + 2.5 W (4.47 V)
- Because Fisher products are subject to continuous improvement, Fisher Corporation reserves the right to make any changes or modifications without notice.

PRODUCT SAFETY NOTICE

Each precaution in this manual should be followed during servicing. Components identified with the IEC symbol in the parts list and the schematic diagram designate components in which safety can be of special significance. When replacing a component identified with , use only the replacement parts designated, or parts with the same ratings of resistance, wattage or voltage that are designated in the parts list in this manual. Leakage-current or resistance measurements must be made to determine that exposed parts are acceptably insulated from the supply circuit before returning the product to the customer.

SEMICONDUCTOR LEAD IDENTIFICATION

INTEGRATED CIRCUITS

DC AMP IC

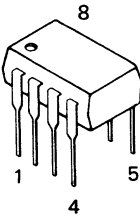

- NJM 072

LEVEL METER IC

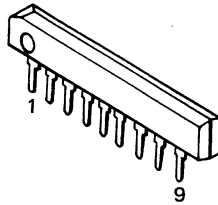

- LB 1423

POWER AMPLIFIER IC

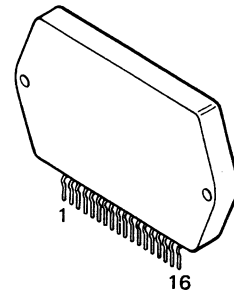

- STK 2025

TRANSISTORS

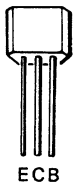

- 2SD 1012



- 2SK 332

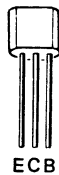

- 2SC 536
- 2SC 2362
- 2SA 1016
- 2SA 608



- 2SB 560

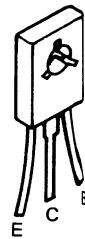

- 2SD 612K

DIODES

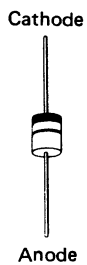

- DS 135D

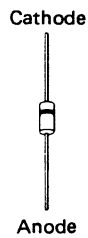

- DS 430
- GZA 16Y
- GMA 01

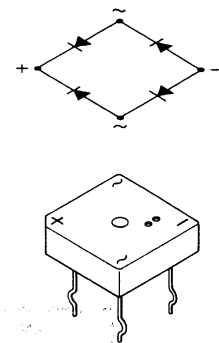

- DBA 20