

# SERVICE MANUAL



# FISHER

## CA-9335

(XE)

### Stereo Amplifier

with RCA-9335 Wireless Remote Control

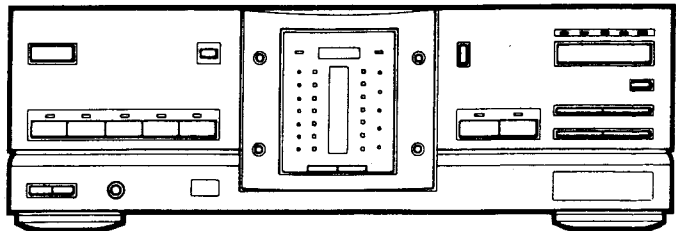

### Specifications

#### Main Amplifier

Continuous minimum sine wave RMS power output per channel at 6 ohms from 40 Hz to 20 kHz with no more than 10% total harmonic distortion  
..... 110 Watts

#### Surround Amplifier(SURROUND)

Continuous minimum sine wave RMS power output per channel at 1 kHz into 8 ohms with no more than 0.9% total harmonic distortion  
..... 15 Watts

#### Center Amplifier(CENTER)

Continuous minimum sine wave RMS power output at 1 kHz into 8 ohms with no more than 0.9% total harmonic distortion  
..... 15 Watts

Power bandwidth 40Hz~20kHz  
Total harmonic distortion(at half rated power output)  
Main/Surround(1kHz) 0.09%  
1.M.Distortion 0.9%

#### Input level and impedance

PHONO ..... 2.5mV/47kohm  
CD ..... 300mV/47kohm  
TUNER ..... 300mV/47kohm  
TAPE-1/TAPE-2(PLAY) ..... 300mV/47kohm  
VIDEO-1/VIDEO-2-(VIDEO IN) 1Vp-p/75ohm  
VIDEO-1/VIDEO-2-(AUDIO OUT) 300mV/47kohm

#### Outputs

TAPE-1/TAPE-2(REC) ..... 300mV/47kohm  
VIDEO-1/VIDEO-2-(VIDEO OUT) 1Vp-p/75ohm  
VIDEO-1/VIDEO-2-(AUDIO OUT) 300mV/47kohm  
MONITOR OUT ..... 1Vp-p/75ohm  
FRONT SPEAKERS ..... 8ohm  
CENTER SPEAKERS ..... 8ohm  
SURROUND SPEAKERS ..... 8ohm  
PHONES ..... 8ohm  
Graphic equalizer ..... 5-Mode sound preset  
Loudness control(100Hz/10kHz) +8dB/+4dB  
Power requirements ..... AC230V, 50Hz  
Power consumption ..... 235 Watts  
Dimension ..... Approx. 16.5" x 5.7" x 13.4"  
(W x H x D)  
Weight ..... Approx. 24.8lbs

PRODUCT CODE No.  
129 413 02

#### RCA-9335 WIRELESS REMOTE CONTROL (43-Functions)

Power requirements ..... DC 3V, Two "AA" batteries  
Dimensions (W x H x D) Approx. 2.5" x 6.9" x 0.7"  
Weight ..... Approx. 2 oz (without batteries)

"Dolby" and the double-D symbol  are trademark of Dolby Laboratories Licensing Corporation. Dolby Noise Reduction system is manufactured under license from Dolby Laboratories Licensing Corporation.

### IMPORTANT INFORMATION

Because its products are subject to continuous improvement, FISHER reserves the right to modify product designs and specification without notice and without incurring any obligation.

REFERENCE No. SM580275

# EXPLODED VIEW (CABINET & CHASSIS)

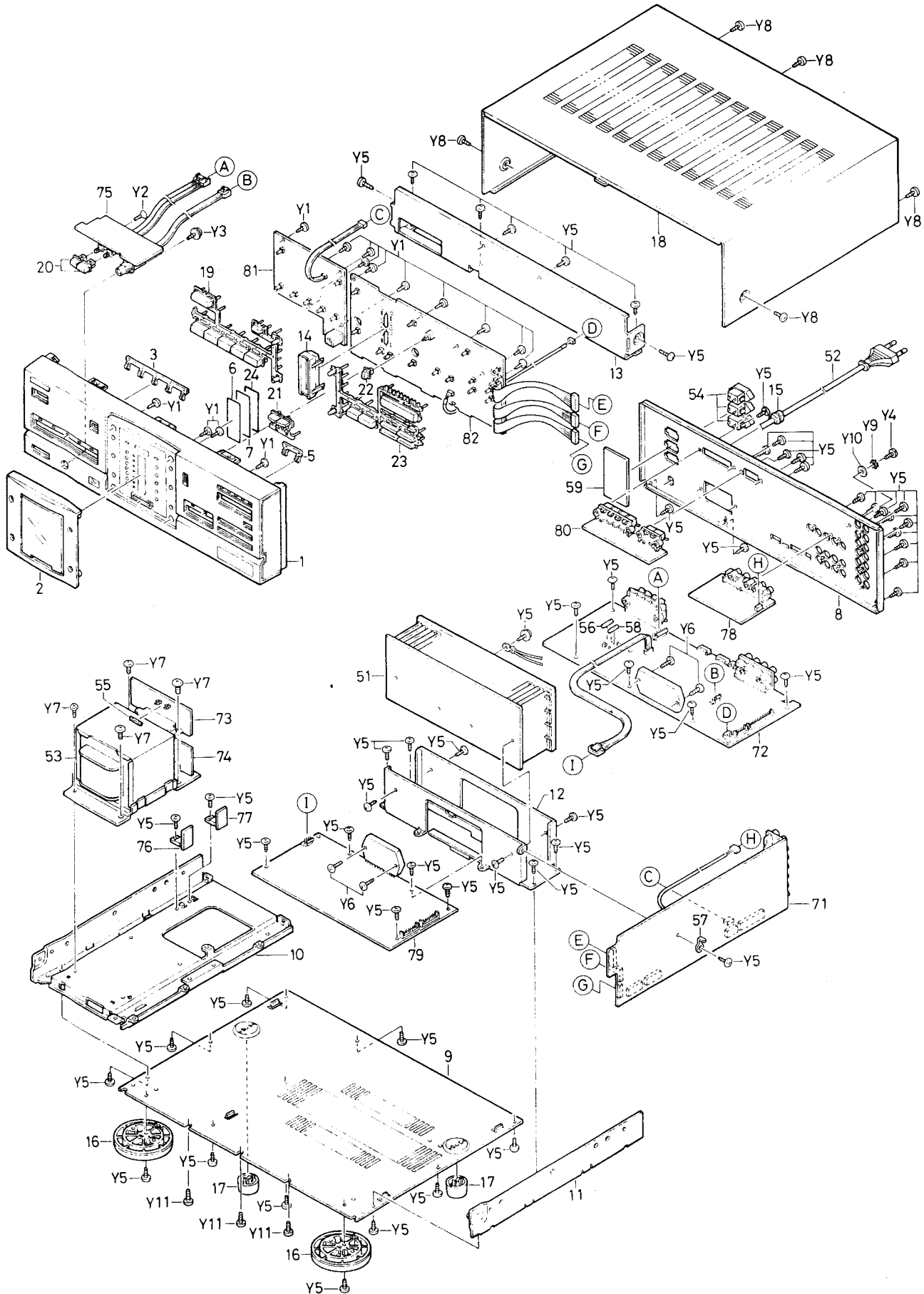

## PARTS LIST

### PRODUCT SAFETY NOTICE

Each precaution in this manual should be followed during servicing. Components identified with the IEC symbol  $\Delta$  in the parts list and the schematic diagram designate components in which safety can be of special significance. When replacing a component identified  $\Delta$ , use only the replacement parts designated, or parts with the same ratings of resistance, wattage or voltage that are designated in the parts list in this manual. Leakage-current or resistance measurements must be made to determine that exposed parts are acceptably insulated from the supply circuit before returning the product to the customer.

**CAUTION:** Regular type resistors and capacitors are not listed. To know those values, refer to the schematic diagram.

### PACKING & ACCESSORIES

Ref. No.	Part No.	Description
	614 256 3793	INNER CARTON
	614 256 3816	PAD
	614 256 3823	PAD
	614 256 3892	INSTRUCTION MANUAL
	614 244 0254	INNER POLYE COVER,UNIT
	614 257 5895	SHEET,UNIT
	614 246 0443	INNER POLYE COVER,ACCESSORY

### CABINET & CHASSIS

Ref. No.	Part No.	Description
1	614 257 0104	ASSY, PANEL, FRONT
2	614 249 1959	ASSY, ESCUTCHEON
3	614 248 5354	INDICATOR, FUNCTION
5	614 248 5347	INDICATOR, VIDEO
6	614 248 5569	SHEET, SCATTER
7	614 248 5507	FILTER
8	614 256 3557	PANEL, REAR
9	614 248 5118	PLATE, BOTTOM
10	614 248 5446	BRACKET-M, P.T., OTHER L
11	614 248 5408	BRACKET-E, PCB FIX R
12	614 248 5453	BRACKET-M, HEAT SINK
13	614 248 5460	BRACKET-M, FRONT SIDE
14	614 248 5545	REFLECTOR
15	614 129 1901	FIXER, AC CORD
16	614 249 1577	ASSY, FOOT, FRONT
17	614 249 1584	ASSY, FOOT, BACK
18	614 256 4257	CABINET
19	614 248 5279	BUTTON, POWER, DOL, FUNC, SUR, DELAY
20	614 248 5286	BUTTON, SPEAKERS
21	614 248 5309	BUTTON, CENTER VOLUME
22	614 248 5316	BUTTON, LOUDNES
23	614 248 6801	BUTTON, V. FUNC, M. VOL, OTHER
24	614 256 4943	FILTER

### FIXING PARTS

Ref. No.	Part No.	Description
Y1	411 021 1806	SCR S-TPG BIN 2.6X10, ASSY, ESCUTCHEON
Y2	411 101 7407	SCR S-TPG FLT 2.6X10, SP SWITCH
Y3	411 024 6501	SCR S-TPG PAN+FLG 3X8, PHONE SOCKET
Y4	411 148 3509	SCR S-TPG BIN 3X14, GND
Y5	411 021 6405	SCR S-TPG BIN 3X8, FRONT
Y6	411 021 4500	SCR S-TPG BIN 3X16, POWER IC
Y7	411 001 3905	SCR S-TPG BIN 4X6, P.T.
Y8	411 021 6603	SCR S-TPG BIN 3X8, CABINET
Y9	411 008 0402	WASHER OUT TW 3, GND
Y10	411 105 9704	WASHER Z 3X10X1, GND
Y11	412 003 1708	SPECIAL SCREW, PLATE BOTTOM

### ELECTRICAL PARTS

Ref. No.	Part No.	Description
51	614 249 0280	HEAT SINK
52	$\Delta$ 614 023 3100	POWER CORD
or	$\Delta$ 614 023 3148	POWER CORD
or	$\Delta$ 614 255 2513	POWER CORD
or	$\Delta$ 614 233 8971	POWER CORD
53	$\Delta$ 614 257 2122	POWER TRANS
54	$\Delta$ 614 035 4645	SOCKET, AC OUTLET (CN422, 423, 424)
55	$\Delta$ 423 016 7908	FUSE 250V 2.5A
56	$\Delta$ 423 016 8103	FUSE 250V 4A (FU490)
57	614 129 9082	Lug
58	$\Delta$ 423 016 8103	FUSE 250V 4A (FU491)
59	614 256 1102	AC OUTLET PCB

### MICRO-PROCESSOR PCB ASSY

Ref. No.	Part No.	Description
71	614 256 7050	ASSY, PCB, U-COM
C4001	403 086 2607	NP-ELECT 1U M 50V
C4519	403 067 8208	MT-COMPO 0.068U J 50V
C4619	403 067 8208	MT-COMPO 0.068U J 50V
CN470	614 249 8620	SOCKET, 4P
CN471	614 249 8620	SOCKET, 4P
CN472	614 249 8620	SOCKET, 4P
CN473	614 249 8613	SOCKET, 2P
CN474	614 242 6692	SOCKET, 20P
CN475	614 242 6630	SOCKET, 8P
CN476	614 242 6654	SOCKET, 12P
CN477	614 242 6654	SOCKET, 12P
CN478	614 017 2638	PLUG
CN479	614 017 2607	PLUG
CN480	614 017 2607	PLUG
CN482	614 017 2553	PLUG, 4P
CN483	614 252 9607	ASSY, CONNECTOR-S, 4P TO VIDEO PCB
D4000	407 007 9904	DIODE GMA01
D4001	407 007 9904	DIODE GMA01
D4501	407 005 4505	DIODE DS442X
D4502	407 005 4505	DIODE DS442X
D4503	407 007 9904	DIODE GMA01
D4504	407 005 4505	DIODE DS442X
D4601	407 005 4505	DIODE DS442X
IC421	409 271 2803	IC MC74HC4052N
or	410 177 6802	IC TC74HC4052AP
IC471	409 109 5105	IC LC7821
IC472	409 021 0400	IC LC4966
IC473	409 166 5308	IC TC9215P
IC474	409 018 4909	IC LA6458S
IC475	409 245 9500	IC LC7536
IC476	409 018 4909	IC LA6458S
IC477	409 018 4909	IC LA6458S
IC478	409 245 9500	IC LC7536
IC479	409 018 4503	IC LA6458DS
IC480	409 146 7209	IC LA7222
IC481	410 179 0501	IC UPD75108CW-W64

**PARTS LIST**

Ref. No.	Part No.	Description
IC482	409 018 4909	IC LA6458S
IC483	409 018 4909	IC LA6458S
L4501	614 028 4218	FILTER
Q4501	405 019 4108	TR 2SC536-G-AUD-NP
Q4502	405 019 4108	TR 2SC536-G-AUD-NP
Q4503	405 000 3806	TR DTC114YS
Q4504	405 019 4108	TR 2SC536-G-AUD-NP
Q4505	405 022 5505	TR 2SD1468-R
Q4506	405 004 5004	TR 2SA608-G-NP
Q4601	405 019 4108	TR 2SC536-G-AUD-NP
Q4602	405 019 4108	TR 2SC536-G-AUD-NP
Q4603	405 000 3806	TR DTC114YS
Q4605	405 022 5505	TR 2SD1468-R
Q4609	405 004 5004	TR 2SA608-G-NP
RA490	614 217 1349	RESISTOR
RA491	614 217 1349	RESISTOR
RA492	614 217 1295	RESISTOR
RA493	614 217 1387	RESISTOR
RA494	614 217 1400	RESISTOR
X4352	614 215 5523	RESONATOR, CERAM

Ref. No.	Part No.	Description
D4801	407 005 4505	DIODE DS442X
D4902	407 005 4505	DIODE DS442X
D4903	407 053 6704	ZENER DIODE MTZ5.6B
D4904	407 005 4505	DIODE DS442X
D4905	△407 004 9105	DIODE DSF10C
D4906	407 007 9904	DIODE GMA01
D4907	407 053 6704	ZENER DIODE MTZ5.6B
D4908	407 053 6704	ZENER DIODE MTZ5.6B
D4911	407 005 4505	DIODE DS442X
D4912	407 007 9904	DIODE GMA01
D4913	407 007 9904	DIODE GMA01
D4914	407 005 4505	DIODE DS442X
D4915	△407 004 9105	DIODE DSF10C
D4916	△407 004 9105	DIODE DSF10C
D4917	△407 004 9105	DIODE DSF10C
D4918	△407 004 9105	DIODE DSF10C
D4919	△407 127 1505	DIODE RBV-602LF-A
D4920	△407 077 7800	DIODE RBV-402LF-A
D4921	407 050 5502	ZENER DIODE GZA5.6Y
D4922	407 053 6308	ZENER DIODE MTZ5.1B
D4930	407 005 4505	DIODE DS442X
FPC40	614 208 4540	FUSE HOLDER
FPC41	614 208 4540	FUSE HOLDER
FPC42	614 208 4540	FUSE HOLDER
FPC43	614 208 4540	FUSE HOLDER
IC471	△409 281 6402	IC STK401-120
IC490	△409 078 1900	IC L7805ML
L4701	614 202 1712	V.H.F COIL
L4801	614 202 1712	V.H.F COIL
L4990	614 257 2993	INDUCTOR, FERITE
PO490	408 017 0707	TH PTH9M04BC471TS2F333
PT401	△614 257 2139	POWER TRANS
Q4701	405 022 5505	TR 2SD1468-R
or	405 033 6805	TR 2SD1468S-S
Q4702	405 016 3312	TR 2SC2909-S-AA
or	405 016 3500	TR 2SC2909-T
Q4801	405 022 5505	TR 2SD1468-R
or	405 033 6805	TR 2SD1468S-S
Q4802	405 016 3312	TR 2SC2909-S-AA
or	405 016 3500	TR 2SC2909-T
Q4901	405 016 3500	TR 2SC2909-T
or	405 016 3312	TR 2SC2909-S-AA
Q4902	405 016 3500	TR 2SC2909-T
or	405 016 3312	TR 2SC2909-S-AA
Q4903	405 002 8809	TR 2SA1207-T
or	405 002 8710	TR 2SA1207-S-AA
Q4904	405 004 5004	TR 2SA608-G-NP
Q4905	405 019 4108	TR 2SC536-G-AUD-NP
Q4906	405 019 4108	TR 2SC536-G-AUD-NP
Q4907	405 004 5004	TR 2SA608-G-NP
Q4908	405 019 4108	TR 2SC536-G-AUD-NP
Q4909	405 019 4108	TR 2SC536-G-AUD-NP
Q4920	405 019 4108	TR 2SC536-G-AUD-NP
Q4921	405 004 5004	TR 2SA608-G-NP
Q4922	405 004 5004	TR 2SA608-G-NP
Q4923	405 019 4108	TR 2SC536-G-AUD-NP
Q4924	405 019 4108	TR 2SC536-G-AUD-NP
Q4925	405 019 4108	TR 2SC536-G-AUD-NP
Q4926	405 019 4108	TR 2SC536-G-AUD-NP
Q4927	405 019 4108	TR 2SC536-G-AUD-NP
Q4928	405 004 5004	TR 2SA608-G-NP
Q4999	405 019 3804	TR 2SC536-G-NP
R4705	614 241 3449	RESISTOR 0.22 K- 5W
R4708	401 062 3907	OXIDE-MT 5.6 JA 1W

**MAIN PCB ASSY**

Ref. No.	Part No.	Description
72	614 256 0730	ASSY, PCB, MAIN
C0004	403 057 1202	POLYESTER 0.01U M 50V
C4704	403 057 3800	POLYESTER 0.1U M 50V
C4705	403 057 3800	POLYESTER 0.1U M 50V
C4804	403 057 3800	POLYESTER 0.1U M 50V
C4805	403 057 3800	POLYESTER 0.1U M 50V
C4901	404 057 1001	ELECT 6800U M 80V
C4902	404 057 1001	ELECT 6800U M 80V
C4903	403 200 0205	ELECT 2200U M 35V
C4904	403 200 0205	ELECT 2200U M 35V
C4905	404 029 3804	POLYPRO 0.022U M 200V
C4906	404 029 3804	POLYPRO 0.022U M 200V
C4907	403 057 1202	POLYESTER 0.01U M 50V
C4908	403 057 1202	POLYESTER 0.01U M 50V
C4916	403 086 8500	NP-ELECT 47U M 50V
C4922	△404 000 1607	CERAMIC 0.01U F 400V
or	△404 033 3302	CERAMIC 0.01U M 400V
or	△404 033 3401	CERAMIC 0.01U Z 400V
C4923	403 197 7300	ELECT 1000U M 25V
C4927	403 086 2300	NP-ELECT 1U M 50V
C4932	403 057 3800	POLYESTER 0.1U M 50V
CN400	614 242 6616	PLUG
CN401	614 242 6555	PLUG
CN402	614 249 8620	SOCKET
CN403	614 249 8620	SOCKET
CN406	614 248 7006	TERMINAL
CN407	614 017 1471	PLUG, FROM SP SW
CN408	614 017 1457	PLUG, TO SP SW
CN411	614 020 1253	SOCKET
CN412	614 020 1239	SOCKET
CN418	614 250 8121	ASSY, CONNECTOR-S, MAIN-REAR
CN419	614 020 6555	SOCKET, FOR REG.1
CN420	614 020 6555	SOCKET, FOR REG.2
CN421	614 017 2102	PLUG, 3P MAIN IN
CN425	614 016 8235	PLUG, 4P FOR TUNER
CN426	614 016 8266	PLUG, 7P FOR DECK
CV922	△614 086 2164	COVER, FOR C4922
D4701	407 005 4505	DIODE DS442X

# PARTS LIST

Ref. No.	Part No.	Description
R4709	401 058 1108	OXIDE-MT 10 JA 1W
R4805	614 241 3449	RESISTOR 0.22 K- 5W
R4808	401 062 3907	OXIDE-MT 5.6 JA 1W
R4809	401 058 1108	OXIDE-MT 10 JA 1W
R4909	△401 218 7902	CARBON 180 JB 1/4W
R4910	401 058 4901	OXIDE-MT 10K JA 1W
R4915	401 058 3706	OXIDE-MT 1K JA 1W
R4916	△401 218 7902	CARBON 180 JB 1/4W
RE490	△614 242 7750	RELAY,POWER
RE491	614 242 7767	RELAY
WR401	△614 017 8203	TERMINAL BOARD,AC
WR402	△614 017 8203	TERMINAL BOARD,AC

## PT PRI PCB ASSY

Ref. No.	Part No.	Description
73	614 256 0747	ASSY,PCB,PT PRI
FPC01	614 208 4540	FUSE HOLDER
FPC02	614 208 4540	FUSE HOLDER

## PT SEC PCB ASSY

Ref. No.	Part No.	Description
74	614 256 0754	ASSY,PCB,PT SEC
CN413	614 020 1253	SOCKET

## SP SW PCB ASSY

Ref. No.	Part No.	Description
75	614 256 0778	ASSY,PCB, SP SW
CN409	614 020 1253	SOCKET,6P TO MAIN AMP
CN410	614 020 1239	SOCKET,4P
CN414	614 248 6962	SOCKET
CN415	614 250 8190	ASSY,CONNECTOR-S,TO MAIN AMP 4P
CN416	614 250 8206	ASSY,CONNECTOR-S,TO MAIN AMP 6P
R4710	401 067 5609	OXIDE-MT 330 JA 2W
R4810	401 067 5609	OXIDE-MT 330 JA 2W
S4901	614 250 0095	SWITCH,PUSH
	614 129 9082	LUG

## REG 1 PCB ASSY

Ref. No.	Part No.	Description
76	614 256 0785	ASSY,PCB,REG.1
CN419	614 020 6555	SOCKET, 3P TO MAIN AMP
IC494	△409 078 2402	IC L7812ML,REG.1

## REG 2 PCB ASSY

Ref. No.	Part No.	Description
77	614 256 0815	ASSY,PCB,REG.2
CN420	614 020 6555	SOCKET, 3P TO MAIN AMP
IC493	409 131 3506	IC L79M12ML

## VIDEO PCB ASSY

Ref. No.	Part No.	Description
78	614 256 0822	ASSY,PCB,VIDEO
CN404	614 229 9685	SOCKET
CN405	614 251 4733	SOCKET
CN601	614 017 2553	PLUG
D6000	407 053 6308	ZENER DIODE MTZ5.1B
IC600	409 286 7800	IC HA118104
L6001	614 028 4218	FILTER
Q6000	405 019 4108	TR 2SC536-G-AUD-NP
Q6002	405 019 4108	TR 2SC536-G-AUD-NP
Q6004	405 019 4108	TR 2SC536-G-AUD-NP
Q6005	405 019 4108	TR 2SC536-G-AUD-NP
R6062	401 063 5702	OXIDE-MT 82 JA 1W

## REAR AMP PCB ASSY

Ref. No.	Part No.	Description
79	614 256 0792	ASSY,PCB,REAR AMP
C6703	403 057 3800	POLYESTER 0.1U M 50V
C6704	403 057 3800	POLYESTER 0.1U M 50V
C6707	403 086 2607	NP-ELECT 1U M 16V
C6753	403 057 3800	POLYESTER 0.1U M 50V
C6754	403 057 3800	POLYESTER 0.1U M 50V
C6757	403 086 2607	NP-ELECT 1U M 16V
C6767	403 057 3800	POLYESTER 0.1U M 50V
C6771	403 061 9003	POLYESTER 4700P M 50V
C6772	403 061 9003	POLYESTER 4700P M 50V
C6773	403 060 3101	POLYESTER 0.027U M 50V
C6803	403 057 3800	POLYESTER 0.1U M 50V
C6804	403 057 3800	POLYESTER 0.1U M 50V
C6901	403 057 3800	POLYESTER 0.1U M 50V
C6903	403 057 3800	POLYESTER 0.1U M 50V
C6909	403 067 6204	MT-COMPO 0.15U J 50V
C6910	403 067 6204	MT-COMPO 0.15U J 50V
C6916	403 057 3800	POLYESTER 0.1U M 50V
C6919	403 057 3800	POLYESTER 0.1U M 50V
C6920	403 067 7805	MT-COMPO 0.47U J 50V
C6924	403 057 3800	POLYESTER 0.1U M 50V
C6926	403 057 3800	POLYESTER 0.1U M 50V
C6928	404 060 2606	OS-SOLID 1U M 10V
C6929	404 060 2606	OS-SOLID 1U M 10V
C6940	403 086 8500	NP-ELECT 47U M 50V
CN601	614 242 6579	PLUG
CN602	614 242 6579	PLUG
CN603	614 017 1457	PLUG, 4P FROM MAIN AMP
CN604	614 020 1246	SOCKET
D6701	407 005 4505	DIODE DS442X
D6751	407 005 4505	DIODE DS442X
D6801	407 005 4505	DIODE DS442X
D6903	407 007 9904	DIODE GMA01
D6906	407 007 9904	DIODE GMA01
IC670	△409 274 1407	IC STK400-020
IC671	409 282 0607	IC LA2780N
IC672	409 166 5308	IC TC9215P
IC673	409 204 2009	IC M50198P
IC674	409 080 0007	IC LA2730
L6901	614 028 4218	FILTER
Q4608	405 000 3400	TR DTC114TS
Q6701	405 022 5505	TR 2SD1468-R
or	405 033 6805	TR 2SD1468-S-S
Q6702	405 016 3500	TR 2SC2909-T
or	405 016 3312	TR 2SC2909-S-AA
Q6751	405 022 5505	TR 2SD1468-R
or	405 033 6805	TR 2SD1468-S-S

**PARTS LIST**

**FRONT 1 PCB ASSY**

Ref. No.	Part No.	Description
Q6752	405 016 3500	TR 2SC2909-T
or	405 016 3312	TR 2SC2909-S-AA
Q6802	405 016 3500	TR 2SC2909-T
or	405 016 3312	TR 2SC2909-S-AA
Q6900	405 016 3500	TR 2SC2909-T
or	405 016 3312	TR 2SC2909-S-AA
Q6901	405 016 3500	TR 2SC2909-T
or	405 016 3312	TR 2SC2909-S-AA
Q6903	405 016 3500	TR 2SC2909-T
or	405 016 3312	TR 2SC2909-S-AA
Q6904	405 002 8710	TR 2SA1207-S-AA
or	405 002 8809	TR 2SA1207-T
Q6905	405 016 3500	TR 2SC2909-T
or	405 016 3312	TR 2SC2909-S-AA
Q6906	405 002 8710	TR 2SA1207-S-AA
or	405 002 8809	TR 2SA1207-T
Q6907	405 019 4108	TR 2SC536-G-AUD-NP
Q6908	405 019 4108	TR 2SC536-G-AUD-NP
Q6909	405 004 5004	TR 2SA608-G-NP
Q6910	405 019 4108	TR 2SC536-G-AUD-NP
Q6911	405 019 4108	TR 2SC536-G-AUD-NP
R6704	614 242 0126	RESISTOR 0.22 K- 3W
R6707	401 010 5601	CARBON 5.6 JB 1/2W
R6754	614 242 0126	RESISTOR 0.22 K- 3W
R6757	401 010 5601	CARBON 5.6 JB 1/2W
R6804	614 242 0126	RESISTOR 0.22 K- 3W
R6807	401 010 5601	CARBON 5.6 JB 1/2W
R6930	△402 023 1703	FUSIBLE RES 100 J- 1/4W
R6933	△402 023 1703	FUSIBLE RES 100 J- 1/4W
R6935	△402 023 1703	FUSIBLE RES 100 J- 1/4W
R6936	△402 023 1703	FUSIBLE RES 100 J- 1/4W
X6901	614 251 4740	RESONATOR 3.27MHZ
	614 017 6964	TERMINAL BOARD

Ref. No.	Part No.	Description
D4325	408 018 1505	LED SLP-238C-81-AB,CD
D4326	408 018 1505	LED SLP-238C-81-AB,TAPE2
D4327	408 018 1505	LED SLP-238C-81-AB,TAPE1
IC433	409 303 5109	IC BU4094B
IC436	614 237 8366	OPTO CONNECTOR
Q4340	405 019 4108	TR 2SC536-G-AUD-NP
R4318	401 026 9907	CARBON 4.7K JA 1/6W
R4332	401 015 2704	CARBON 1.8K JA 1/4W
S4317	614 240 1088	SWITCH,TACT,TAPE2
S4318	614 240 1088	SWITCH,TACT,TAPE1
S4319	614 240 1088	SWITCH,TACT,CD
S4320	614 240 1088	SWITCH,TACT,TUNER
S4321	614 240 1088	SWITCH,TACT,PHONO
S4322	614 240 1088	SWITCH,TACT,POWER
S4323	614 240 1088	SWITCH,TACT,DOLBY PRO

**FRONT 2 PCB ASSY**

Ref. No.	Part No.	Description
82	614 248 8935	ASSY,PCB,FRONT 2
C4585	403 067 6907	MT-COMPO 0.027U J 50V
C4685	403 067 6907	MT-COMPO 0.027U J 50V
CN430	614 250 8077	ASSY,CONNECTOR-S
CN431	614 250 8084	ASSY,CONNECTOR-S
CN432	614 250 8091	ASSY,CONNECTOR-S
CN433	614 250 8107	ASSY,CONNECTOR-S,TO FRONT1 6P
CN434	614 250 8114	ASSY,CONNECTOR-S,TO FRONT1 10P
CN441	614 020 6548	SOCKET,MAIN1 2P
CN442	614 020 6548	SOCKET,MAIN2 2P
CN443	614 020 6548	SOCKET,MAIN3 2P
CN444	614 020 6548	SOCKET,MAIN4 2P
CN445	614 020 6548	SOCKET,MAIN5 2P
CN446	614 020 6548	SOCKET,VIDEO1 2P
CN447	614 020 6548	SOCKET,VIDEO2 2P
CN448	614 020 1222	SOCKET 3P
CN449	614 254 7328	ASSY,CONNECTOR-S
D4002	407 007 9904	DIODE GMA01
D4300	408 018 2601	LED SLZ-138C-11-AB-T2
D4301	408 018 2301	LED SLZ-138C-11-AB-T2
D4302	408 018 2601	LED SLZ-138C-11-AB-T2
D4303	408 018 2601	LED SLZ-138C-11-AB-T2
D4304	408 018 2601	LED SLZ-138C-11-AB-T2,ROCK
D4305	408 018 2601	LED SLZ-138C-11-AB-T2,JAZZ
D4306	408 018 2601	LED SLZ-138C-11-AB-T2,EASY
D4307	408 018 2601	LED SLZ-138C-11-AB-T2,FLAT
D4308	408 018 1406	LED SLP-138C-81-AB,MAIN2
D4309	408 018 1406	LED SLP-138C-81-AB,MAIN3
D4310	408 018 1406	LED SLP-138C-81-AB,MAIN4
D4311	408 018 1406	LED SLP-138C-81-AB,MAIN5
D4312	408 018 1505	LED SLP-238C-81-AB,VIDEO1
D4313	408 018 1505	LED SLP-238C-81-AB,VIDEO2
D4314	408 018 1406	LED SLP-138C-81-AB,MAIN1
D4315	408 018 2601	LED SLZ-138C-11-AB-T2,3CH
D4316	408 018 2601	LED SLZ-138C-11-AB-T2,NOR
D4317	408 018 2601	LED SLZ-138C-11-AB-T2,WIDE
D4318	408 018 2601	LED SLZ-138C-11-AB-T2
D4319	408 018 1505	LED SLP-238C-81-AB
D4320	408 018 1505	LED SLP-238C-81-AB
D4321	408 018 1505	LED SLP-238C-81-AB
D4322	408 018 2601	LED SLZ-138C-11-AB-T2

**REAR SP PCB ASSY**

Ref. No.	Part No.	Description
80	614 256 0808	ASSY,PCB,REAR SP
C0010	403 063 5706	POLYESTER 8200P K 50V
C0011	403 063 5706	POLYESTER 8200P K 50V
C0012	403 063 5706	POLYESTER 8200P K 50V
C0013	403 063 5706	POLYESTER 5600P M 50V
CN605	614 020 1246	SOCKET
CN606	614 248 7013	TERMINAL
CN607	614 248 7020	TERMINAL
	614 129 9082	LUG

**FRONT 1 PCB ASSY**

Ref. No.	Part No.	Description
81	614 248 8928	ASSY,PCB,FRONT 1
CN436	614 020 6548	SOCKET,PHONO
CN437	614 020 6548	SOCKET,TUNER
CN438	614 020 6548	SOCKET,CD
CN439	614 020 6548	SOCKET,TAPE2
CN440	614 020 6548	SOCKET,TAPE1
CN451	614 035 4935	SOCKET,TO U-COM PCB 4P
CN452	614 252 9591	ASSY,CONNECTOR-S
D4323	408 018 1505	LED SLP-238C-81-AB,PHONO
D4324	408 018 1505	LED SLP-238C-81-AB,TUNER

# PARTS LIST

Ref. No.	Part No.	Description
D6700	408 018 2601	LED SLZ-138C-11-AB-T2, REAR1
D6701	408 018 2601	LED SLZ-138C-11-AB-T2, REAR2
D6702	408 018 2601	LED SLZ-138C-11-AB-T2, REAR3
D6703	408 018 2601	LED SLZ-138C-11-AB-T2, REAR4
D6704	408 018 2601	LED SLZ-138C-11-AB-T2, REAR5
D6705	408 018 2601	LED SLZ-138C-11-AB-T2, REAR6
D6706	408 018 2601	LED SLZ-138C-11-AB-T2, REAR7
D6750	408 018 2601	LED SLZ-138C-11-AB-T2, CENTER1
D6751	408 018 2601	LED SLZ-138C-11-AB-T2, CENTER2
D6752	408 018 2601	LED SLZ-138C-11-AB-T2, CENTER3
D6753	408 018 2601	LED SLZ-138C-11-AB-T2, CENTER4
D6754	408 018 2601	LED SLZ-138C-11-AB-T2, CENTER5
D6755	408 018 2601	LED SLZ-138C-11-AB-T2, CENTER6
D6756	408 018 2601	LED SLZ-138C-11-AB-T2, CENTER7
D6757	408 018 2601	LED SLZ-138C-11-AB-T2, MUTE
IC430	409 303 5109	IC BU4094B
IC431	409 303 5109	IC BU4094B
IC432	409 303 5109	IC BU4094B
IC434	409 018 4909	IC LA6458S
IC435	409 245 9500	IC LC7536
LP401	614 045 9647	LAMP
LP402	614 045 9647	LAMP

Ref. No.	Part No.	Description
Q4341	405 019 4108	TR 2SC536-G-AUD-NP
Q4343	405 019 4108	TR 2SC536-G-AUD-NP
Q4942	405 019 4108	TR 2SC536-G-AUD-NP
Q4944	405 019 4108	TR 2SC536-G-AUD-NP
S4300	614 240 1088	SWITCH, TACT, MAIN UP
S4301	614 240 1088	SWITCH, TACT, MAIN DOWN
S4302	614 240 1088	SWITCH, TACT, MUTE
S4303	614 240 1088	SWITCH, TACT, BAL L
S4304	614 240 1088	SWITCH, TACT, BAL R
S4305	614 240 1088	SWITCH, TACT, REAR UP
S4306	614 240 1088	SWITCH, TACT, REAR DOWN
S4307	614 240 1088	SWITCH, TACT, CENTER UP
S4309	614 240 1088	SWITCH, TACT, PRESET SOUND
S4310	614 240 1088	SWITCH, TACT, C. MODE
S4311	614 240 1088	SWITCH, TACT, DELAY TIME
S4313	614 240 1088	SWITCH, TACT, TEST TONE
S4314	614 240 1088	SWITCH, TACT, CENTER DOWN
S4315	614 240 1088	SWITCH, TACT, VIDEO 2
S4316	614 240 1088	SWITCH, TACT, VIDEO 1
S4701	614 248 7105	SWITCH, PUSH, LOUDNESS

## REMOTE CONTROL ASSY (RCA-9335)

Ref. No.	Part No.	Description
	614 254 2910	ASSY, REMOCON
	614 254 2897	LID, BATTERY
	614 254 3245	POLY COVER

## IC BLOCK DIAGRAM

NOTE : Please look at the Schematic Diagram if something is not shown in the the BLOCK DIAGRAM.

### < FRONT SECTION >

### IC430~433 BU4094B (8Bit Bus-Compatible Shift/Store Resistor)

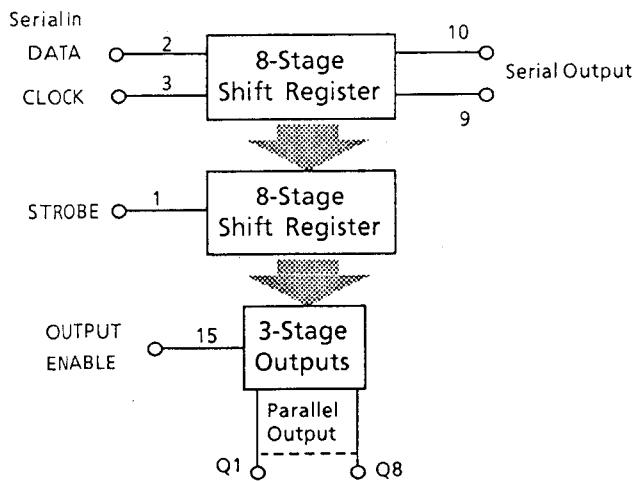

CLK	OE	ST	D	PO		SO	
				Q1	Qn	Qs	Q's
↑	H	H	L	L	Qn~1	Q7	NC
↑	H	H	H	H	Qn~1	Q7	NC
↑	H	L	*	NC	NC	Q7	NC
↑	L	*	*	HZ	HZ	Q7	NC
↓	H	*	*	NC	NC	Q7	Qs
	L	*	*	HZ	HZ	Q7	Qs

CLK = CLOCK                      \* = Don't care  
 OE = Output Enable              NC = No Change  
 ST = Strobe                        HZ = High Impedance  
 PO = Parallel Output  
 SO = Serial Output                D = Serial In

## IC BLOCK DIAGRAM

IC479 LA6458S (Dual Ope-Amplifier)  
MICOM SECTION (IC474,476,477,482,483)

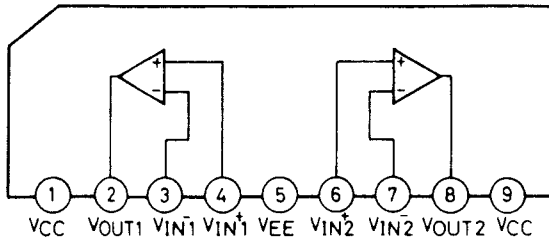

IC435 LC7536 (Serial Control Electronic Volume)

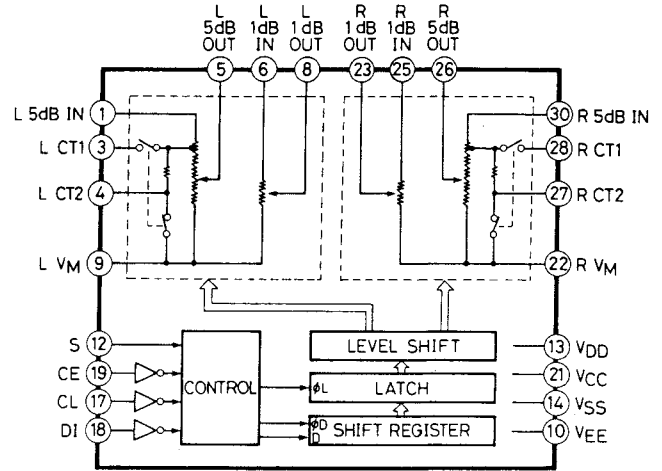

### < VIDEO SECTION >

IC600 HA118104 (Triple Selection Switch for Video Signal)

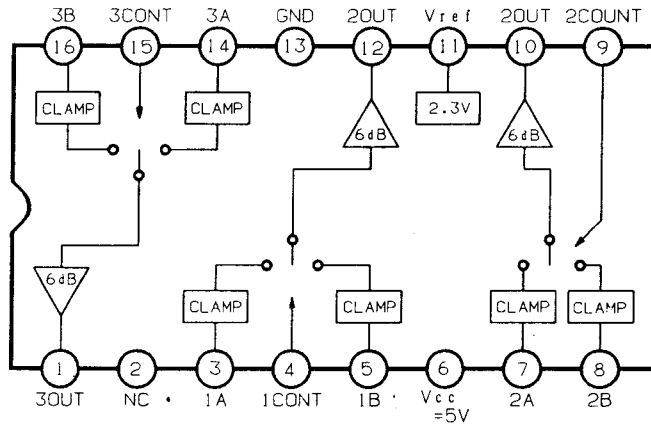

### < MICOM SECTION >

IC421 MC74HC4052N or TC74HC4052AP (Dual 2-input 4-ch Analog Multiplexer/De-multiplexer)

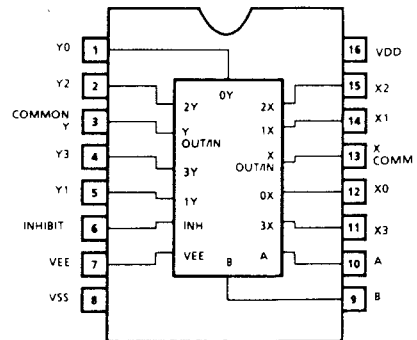
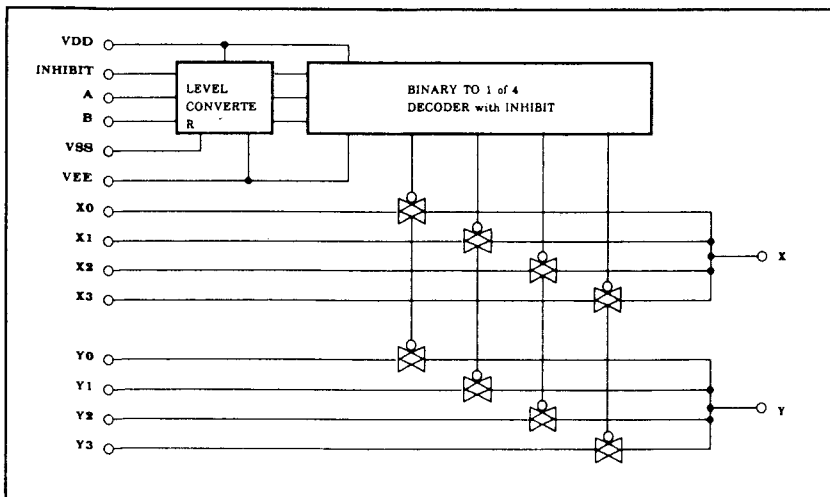

TRUTH TABLE

CONTROL INPUTS			[ON] CHANNEL
INHIBIT	A	B	
L	L	L	X0 Y0
L	H	L	X1 Y1
L	L	H	X2 Y2
L	H	H	X3 Y3
H	X	X	NONE

X : DON'T CARE



# IC BLOCK DIAGRAM

IC471 LC7821 (Analog Function Switch)

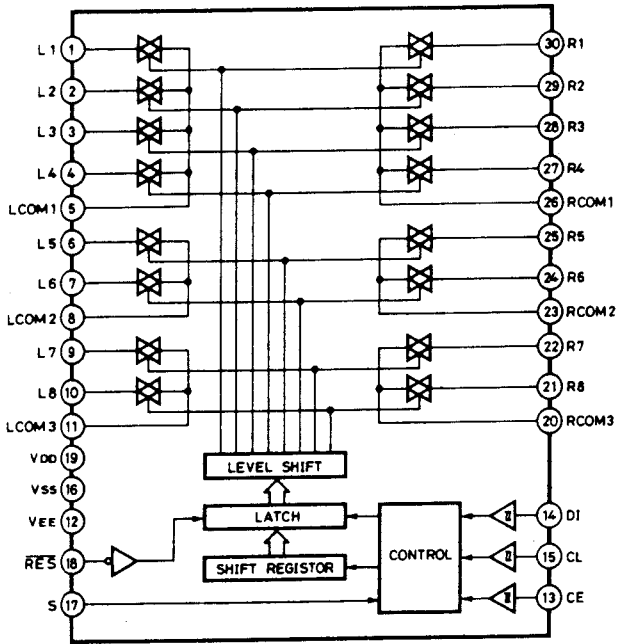

IC472 LC4966 (Quad Bilateral Switch)

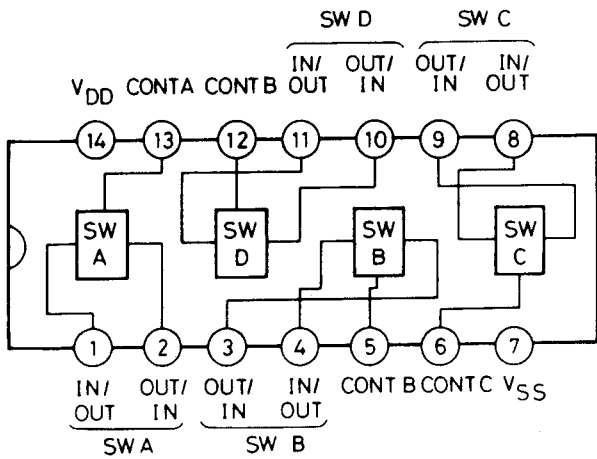

IC473 TC9215P (High Voltage Analog Switch)  
PRE AMP SECTION (IC672)

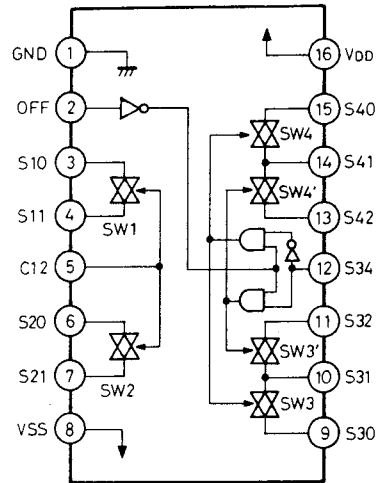

IC474,476,477,482,483 LA6458S (Dual Ope-Amplifier)  
See page 7

IC475,478 LC7536 (Serial Control Electronic Volume)  
See page 7

IC479 LA6458DS (Dual Ope-Amplifier)

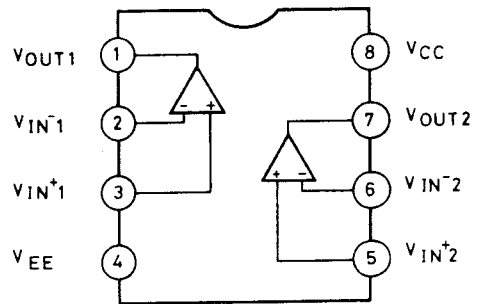

IC480 LA7222(AV SWITCH)

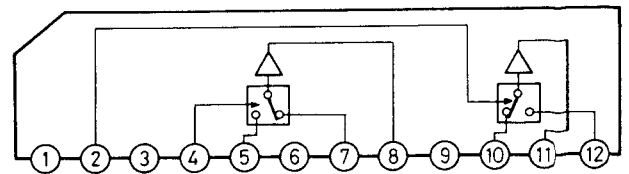

# IC BLOCK DIAGRAM

## IC481 $\mu$ PD75108CW-W64 (Micro Processor)

PIN No.	SIGNAL NAME	DESCRIPTION OF FUNCTION
1	US-S	LATCH DATA /KEY SCAN /TIME STAMP
2	32-S	LATCH DATA /KEY SCAN /TIME STAMP
3	31-S	LATCH DATA /KEY SCAN /TIME STAMP
4	IR	Remote control input
5	NC	Not used
6	KEY2	Key input
7	KEY1	Key input
8	KEY0	Key input
9	NC	Not used
10	NC	Not used
11	SOUND FLAT	Sound Flat Preset Output
12	SOUND B	Sound Preset ROCK/JAZZ/EASY/CLASSICAL Change Output
13	SOUND A	Sound Preset ROCK/JAZZ/EASY/CLASSICAL Change Output
14	BUSY	Not used
15	SI	Not used
16	NC	Not used
17	NC	Not used
18	PDOWN	TEL-LINE SIGNAL SWITCH
19	CDAFIN	LA2805M MUTE CONTROL
20	TAAFIN	LA2805M D2 CONTROL
21	TUAFIN	RX DATA INPUT
22	NC	NOT USE
23	CDAFOUT	POWER SOURCE (GND)
24	TAAFOUT	SYSTEM CLOCK IN
25	15MSEC	
26	20MSEC	
27	30MSEC	
28	NC	Not used
29	SPRELAY	Set Low after Poweron,and High after DCINLOW.
30	P.RELAY	Set Low after POWER ON,and High after POWER OFF. Set POWERRLY High after PDWN LOW input.
31	VDD	Power source. + 5V
32	VDD	Power source. + 5V
33	PHANTOM	Set any port low with DOLBY LOGIC Key in SURROUND ON
34	WIDE	Set any port low with DOLBY LOGIC Key in SURROUND ON

PIN No.	SIGNAL NAME	DESCRIPTION OF FUNCTION
35	NORMAL	Set any port low with DOLBY LOGIC Key in SURROUND ON
36	3-CH	TC8801N START CONTROL
37	NOISE	Set the CH of TESTTONE with TESTTONE Key
38	NOISE	Set the CH of TESTTONE with TESTTONE Key
39	PRO/NOISE	3-CH,PROLOGIC,TEST NOISE generated mode select
40	PRO/NOISE	3-CH,PROLOGIC,TEST NOISE generated mode select
41	PROLOGIC2	LA2780 PROLOGIC mode select
42	PROLOGIC1	LA2780 PROLOGIC mode select
43	NC	RINGER/CPC SIGNAL INPUT
44	CLASSIC	Sound Preset Classic LED ON/OFF Output
45	RESET	System reset input
46	OSC	X'tal circuit:4.19MHz
47	OSC	X'tal circuit:4.19MHz
48	DCIN	KEY SCAN /LC7385M DATA INPUT
49	SUR ON/OFF	Dolby Surround LED / Circuit ON/OFF Output
50	FB	VIDEO1,VIDEO2 video I/O select
51	FA	VIDEO1,VIDEO2 video I/O select
52	NC	LA5550M MOTOR CONTROL L
53	DEL3	M50198(Delay IC) Delay time select mode and delay time select
54	DEL2	M50198(Delay IC) Delay time select mode and delay time select
55	DEL1	M50198(Delay IC) Delay time select mode and delay time select
56	CE	Electrical volume (VOL UP/VOL DOWN) data select
57	CLK	Electrical volume (VOL UP/VOL DOWN) data select
58	DATA	Electrical volume (VOL UP/VOL DOWN) data select
59	STR	4094 Strobe Output
60	AV2	LC4966/TC9125 Sound I/O of VIDEO1,VIDEO2 select
61	AV1	LC4966/TC9125 Sound I/O of VIDEO1,VIDEO2 select
62	-20dB	Audio mute output. Last memoried.
63	FMUTE	Full Mute Output
64	GND	GND

## < REAR AMP. SECTION >

### IC671 LA2780 (Dolby Pro Logic Decoder)

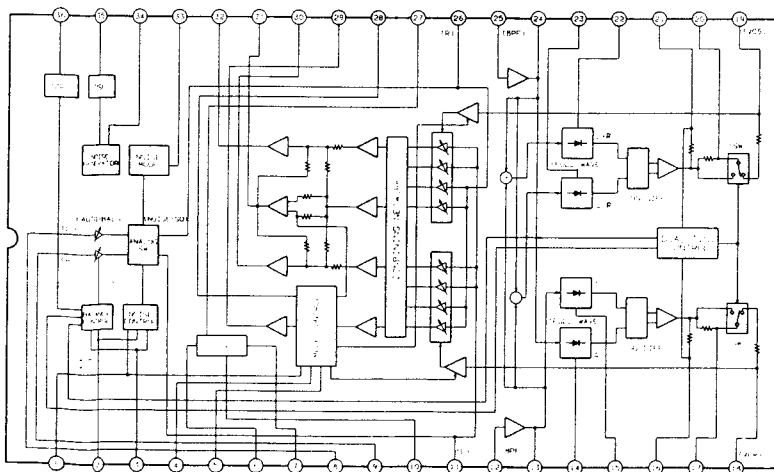

# IC BLOCK DIAGRAM

## IC671 LA2780

PIN No.	DESCRIPTION OF FUNCTION
1	Switch for 3 Channel Logic/Pro Logic/Noise Sequencer
2	Noise Sequencer LSB
3	Noise Sequencer LSB/Auto Balance On/Off Switch
4	Center Mode Control Switch 1
5	Center Mode Control Switch 2
6	Vrfq
7	AC GND.
8	LT Input
9	RT Input
10	GND.
11	LT Output ( Noise Sequencer/Auto Balance Output)
12	LT Buffer Input for Full Wave Rectifier
13	LT Buffer Output for Full Wave Rectifier
14	R Smoothing Capacitor for Full Wave Rectifier
15	L Smoothing Capacitor for Full Wave Rectifier
16	VLR Smoothing Capacitor for Dual Time Constant Threshold
17	VLR Smoothing Capacitor for Dual Time Constant
18	VLR Smoothing Capacitor for Dual Time Constant

PIN No.	DESCRIPTION OF FUNCTION
19	VCS Smoothing Capacitor for Dual Time Constant
20	VCS Smoothing Capacitor for Dual Time Constant
21	VCS Smoothing Capacitor for Dual Time Constant Threshold
22	L + R Smoothing Capacitor for Full Wave Rectifier
23	L - R Smoothing Capacitor for Full Wave Rectifier
24	RT Buffer Output for Full Wave Rectifier
25	RT Buffer Input for Full Wave Rectifier
26	RT Output ( Noise Sequencer/Auto Balance Output)
27	Vcc
28	Capacitor for Center Mode Control
29	S Channel Output
30	R Channel Output
31	C Channel Output
32	L Channel Output
33	Pseudo Random Noise Input
34	Pseudo Random Noise Output
35	Oscillation Capacitor for Pseudo Random Noise Generator
36	Oscillation Capacitor for Auto Balance

## IC672 TC9215P (High Voltage Analog Switch) See page 8

## IC673 M50198P (1 Chip Digital Delay)

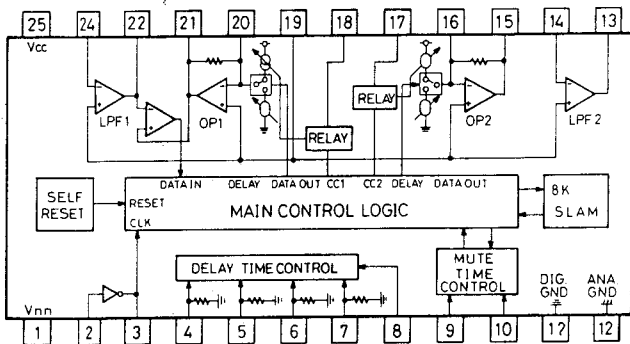

## IC674 LA2730 (Dolby System Encode/Decode)

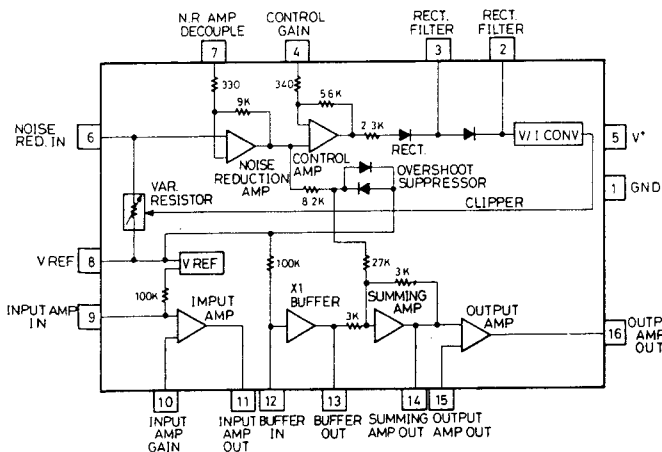

## < MAIN AMP. SECTION >

## IC471 STK401-120 (2 Channel AF Power Amp.)

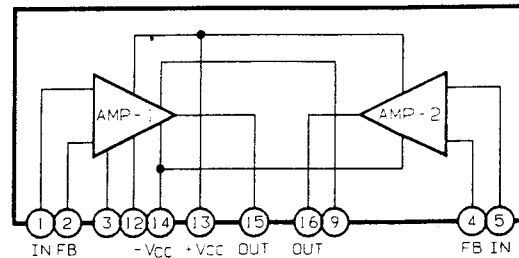

## IC490 L7805ML (3-Terminal 5V Voltage Regulator) IC494 L7812ML (3-Terminal 12V Voltage Regulator)

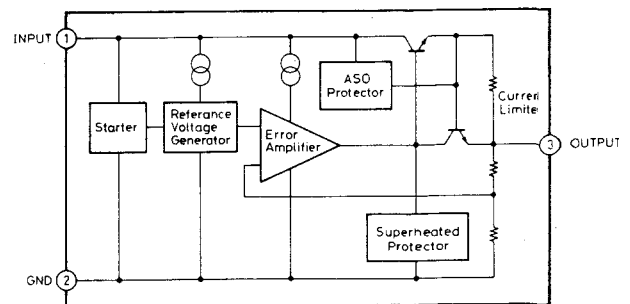

## IC493 L79M12ML (3-Terminal 12V Voltage Regulator)

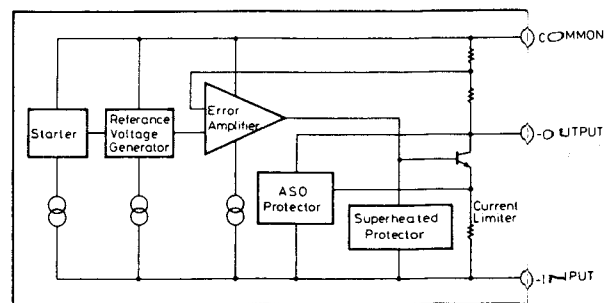

SCHEMATIC DIAGRAM (VIDEO SELECT)

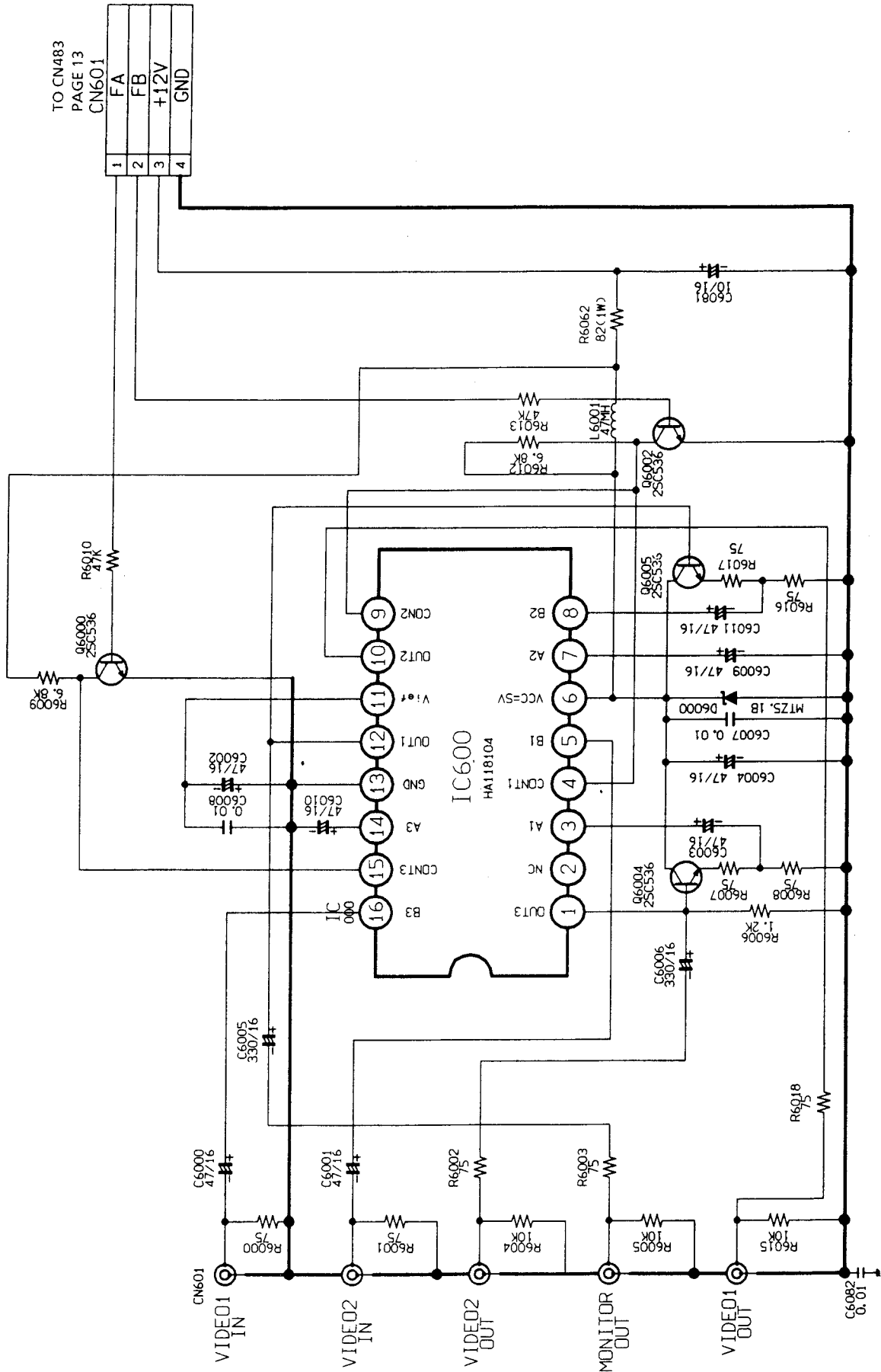

TO CN483  
PAGE 13  
CN601

1	FA
2	FB
3	+12V
4	GND

**SCHEMATIC DIAGRAM (MICRO PROCESSOR CONTROL)**

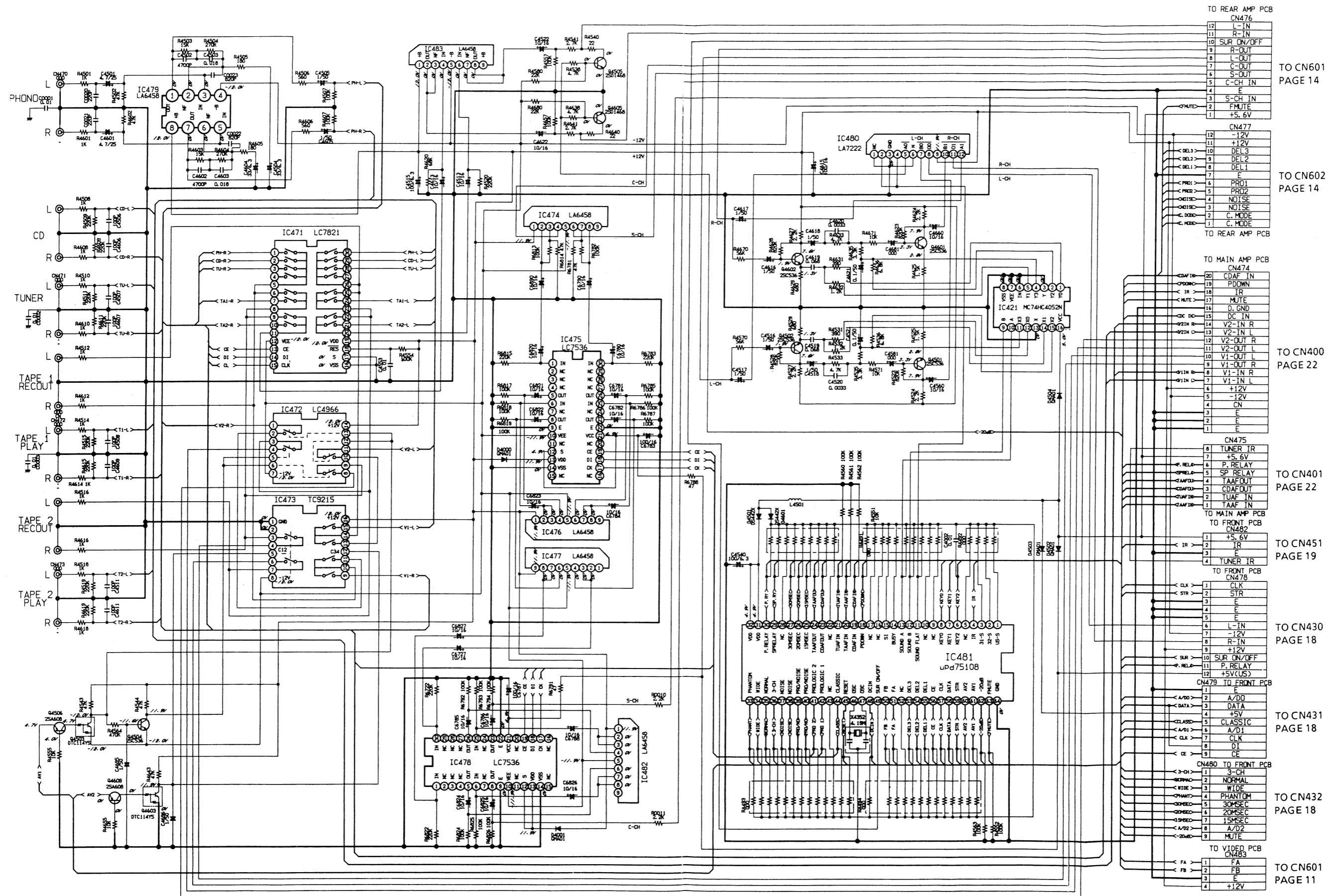

**SCHEMATIC DIAGRAM (DOLBY SURROUND)**

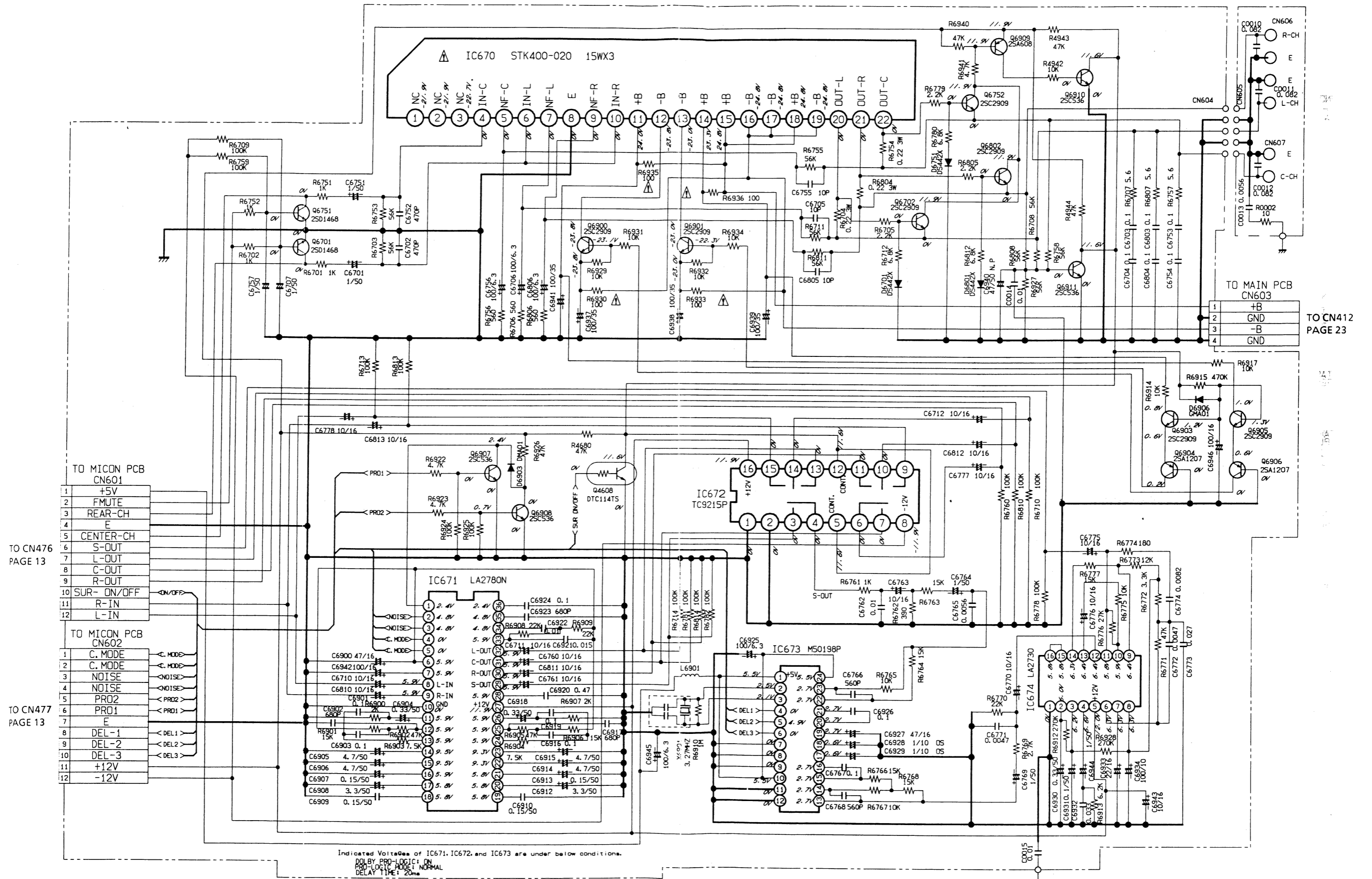

WIRING DIAGRAM (VIDEO.MICRO PROCESSOR CONTROL & DOLBY SURROUND)

①② TO FRONT PCB PAGE 21

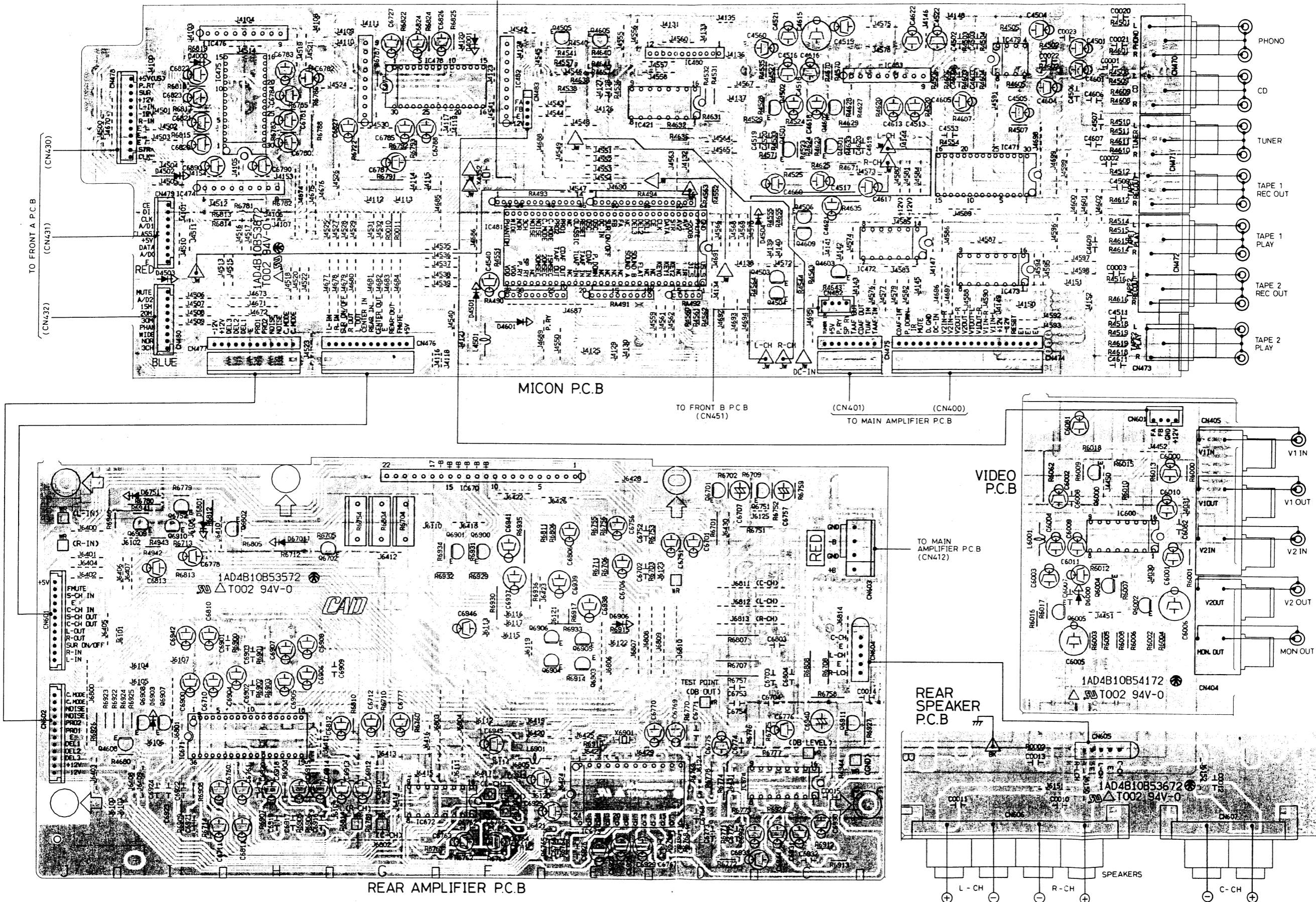

**SCHEMATIC DIAGRAM (FRONT)**

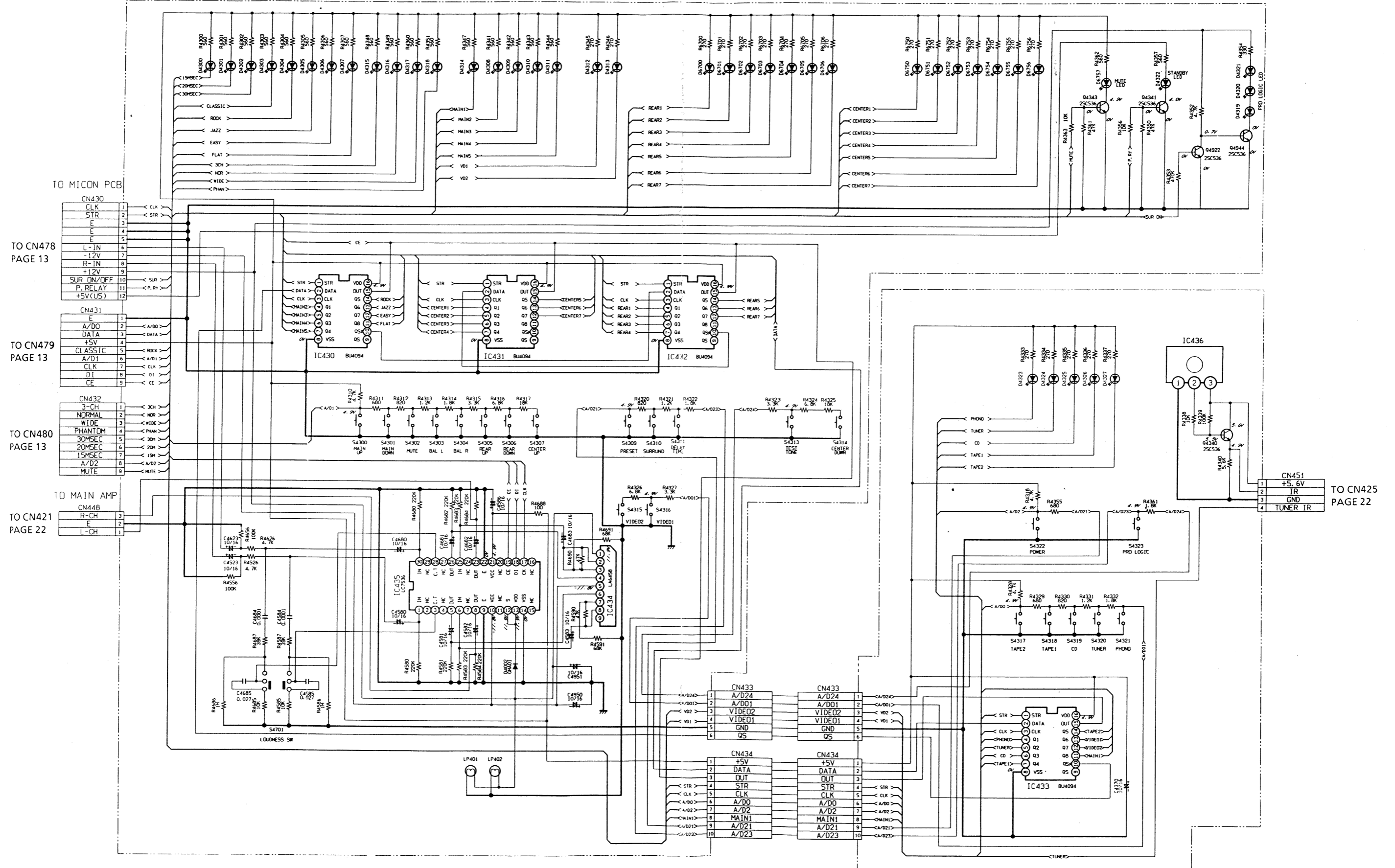



WIRING DIAGRAM (FRONT)

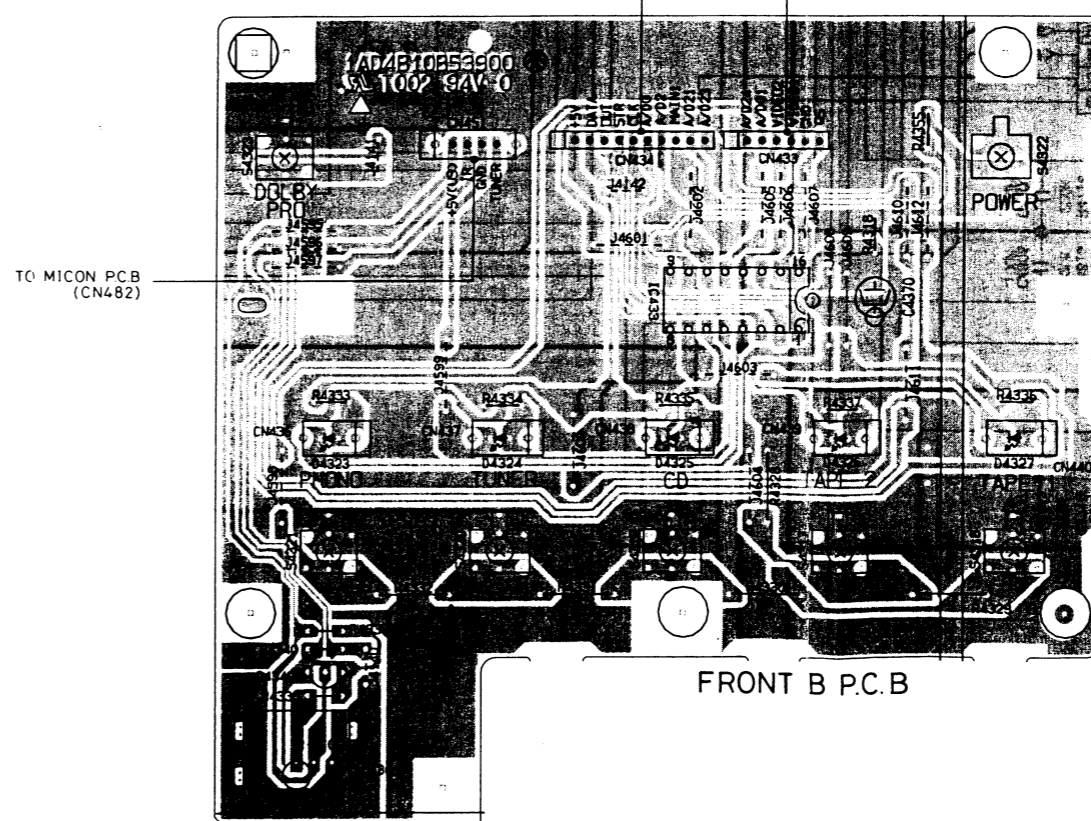
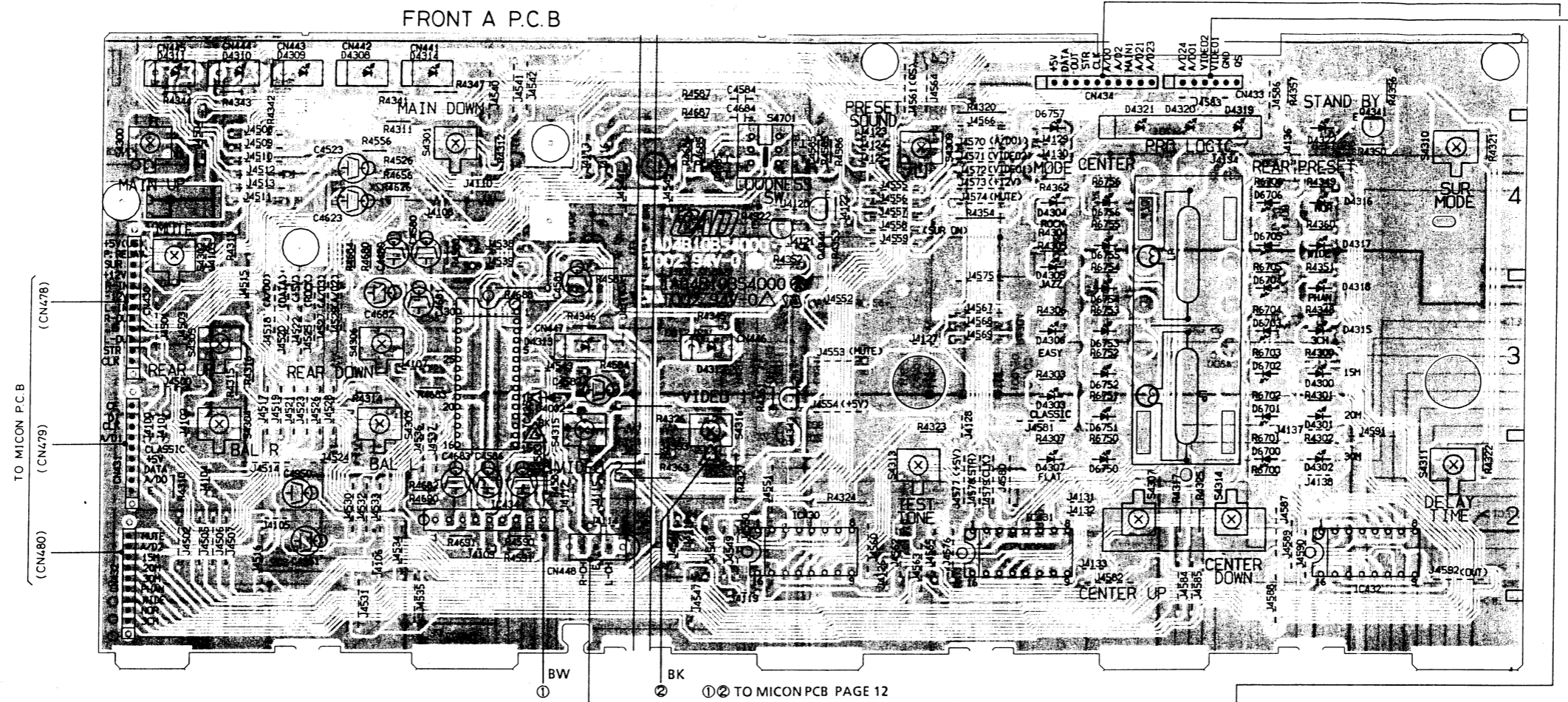

SCHEMATIC DIAGRAM (MAIN AMP SECTION)

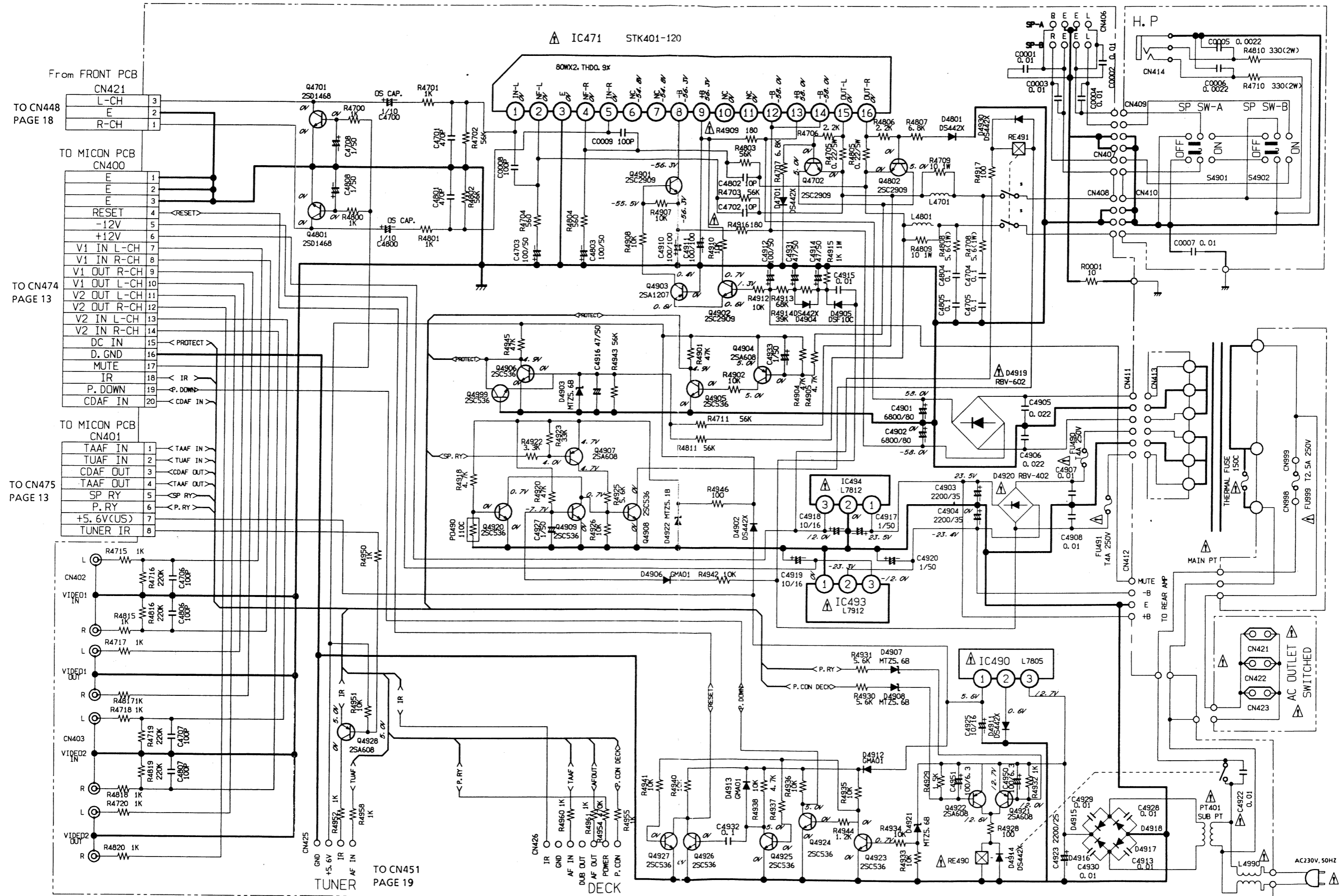

WIRING DIAGRAM (MAIN AMP SECTION)

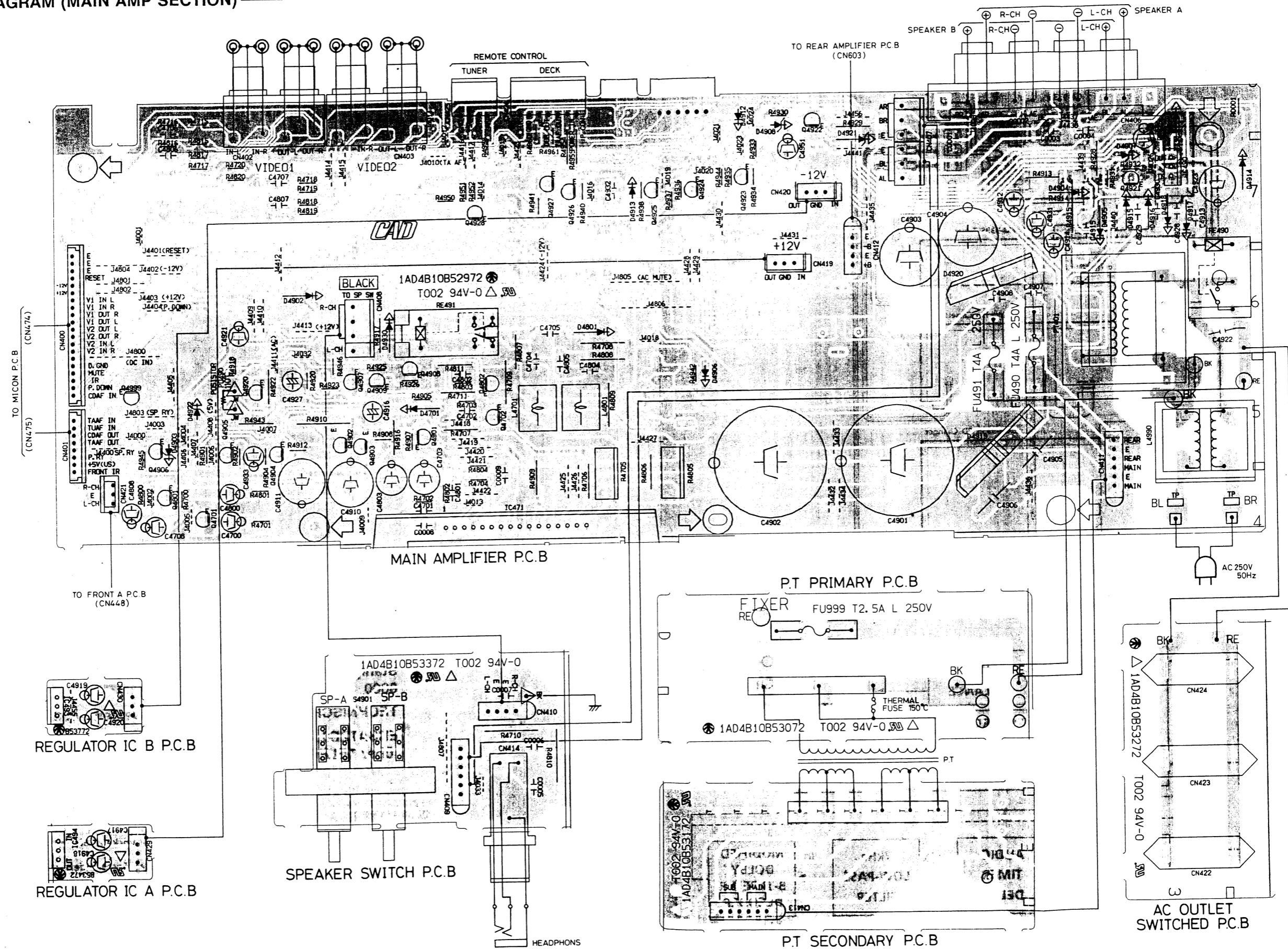

CONNECTIONS

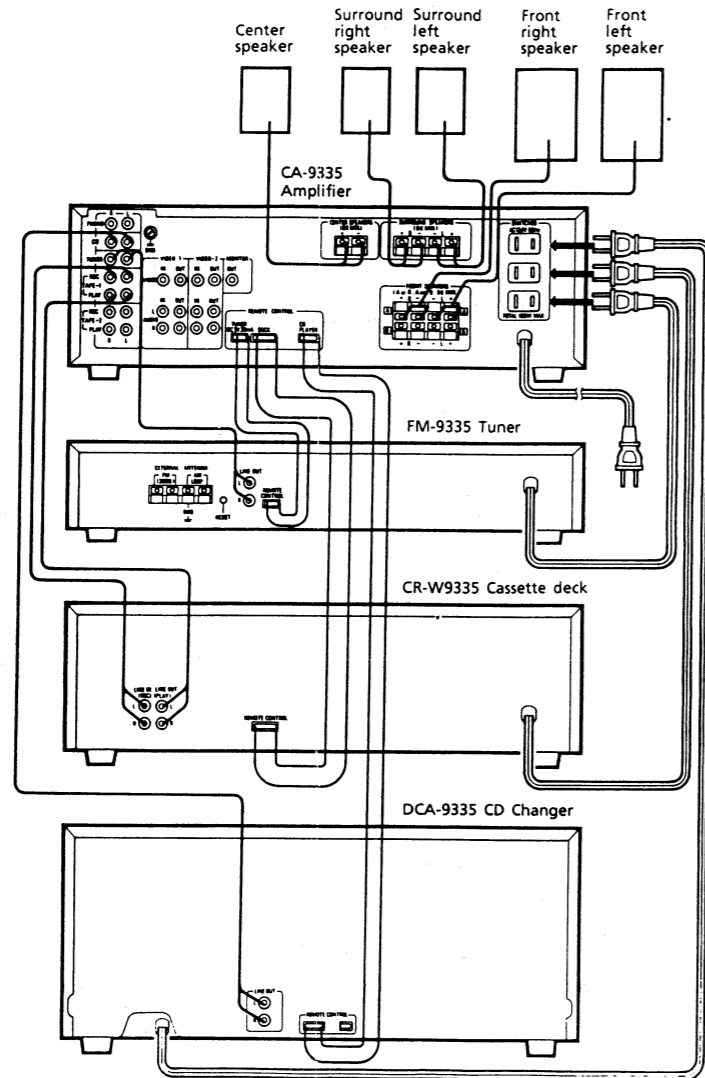

ACTIVE SURROUND DECODER BLOCK DIAGRAM

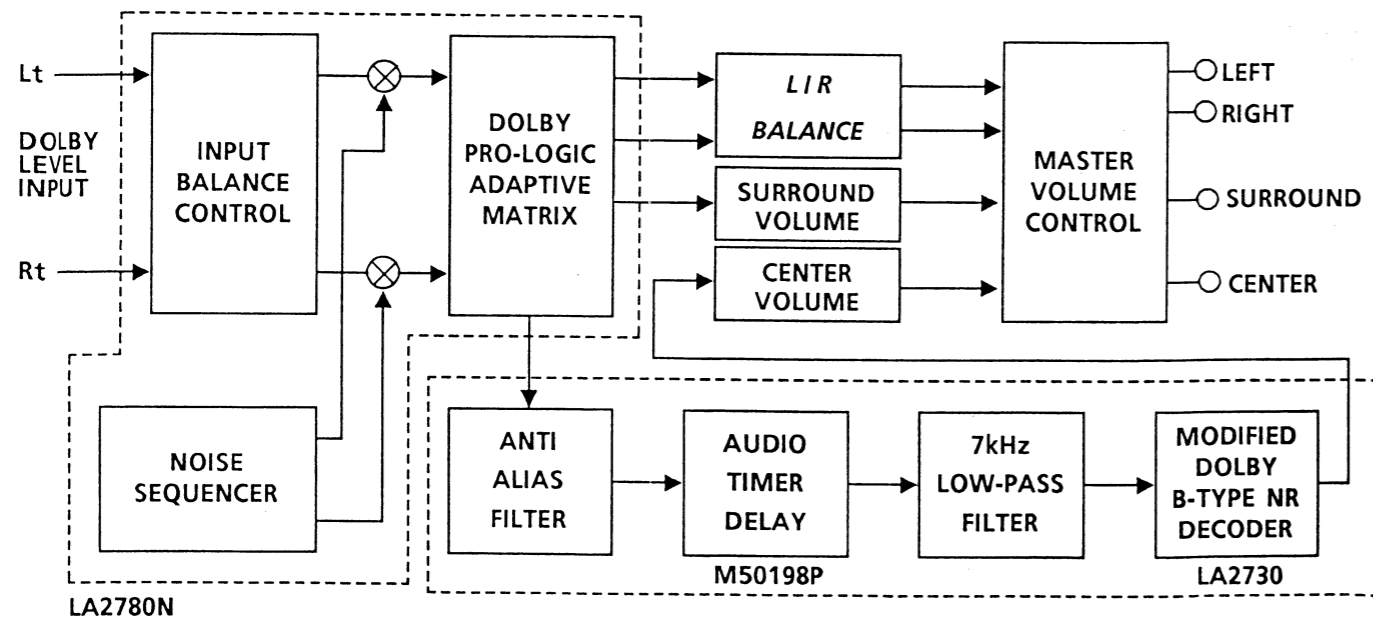

SANYO FISHER Vertriebs GmbH

Stahlgruberring 4    Tel : 089/420 45-0  
8000 München 82    Tlx : 524033

TECHNISCHE AUSKÜNFTE / Durchwahlen -168/-171/-172/-173

ERSATZTEIL-AUFTRAGSANNAHME  
über TELEFAX-Nr.    42045 -135  
   -137  
   -157  
   -158

Unser FISHER-Team steht Ihnen jederzeit gerne zur Verfügung. Ersatzteilbestellungen wickeln Sie bitte ausschließlich mit unserer Service-Zentrale München ab. Senden Sie uns im Garantiefall Ihren Kaufbeleg ein. Bei unverkauften Lagergeräten des Fachhandels gilt als Garantienachweis eine eidesstattliche Versicherung mit eingetragener Modellbezeichnung und Geräte-Nummer oder ein Liefernachweis. Die gleiche Regelung besteht auch für Reparaturaufträge. Bitte geben Sie unbedingt die Ersatzteil-Nummer und die Modellbezeichnung an. Sie sparen so wertvolle Zeit. Vielen Dank.