

SERVICE MANUAL



FISHER

CC-7000

Control Amplifier
(EUROPE)

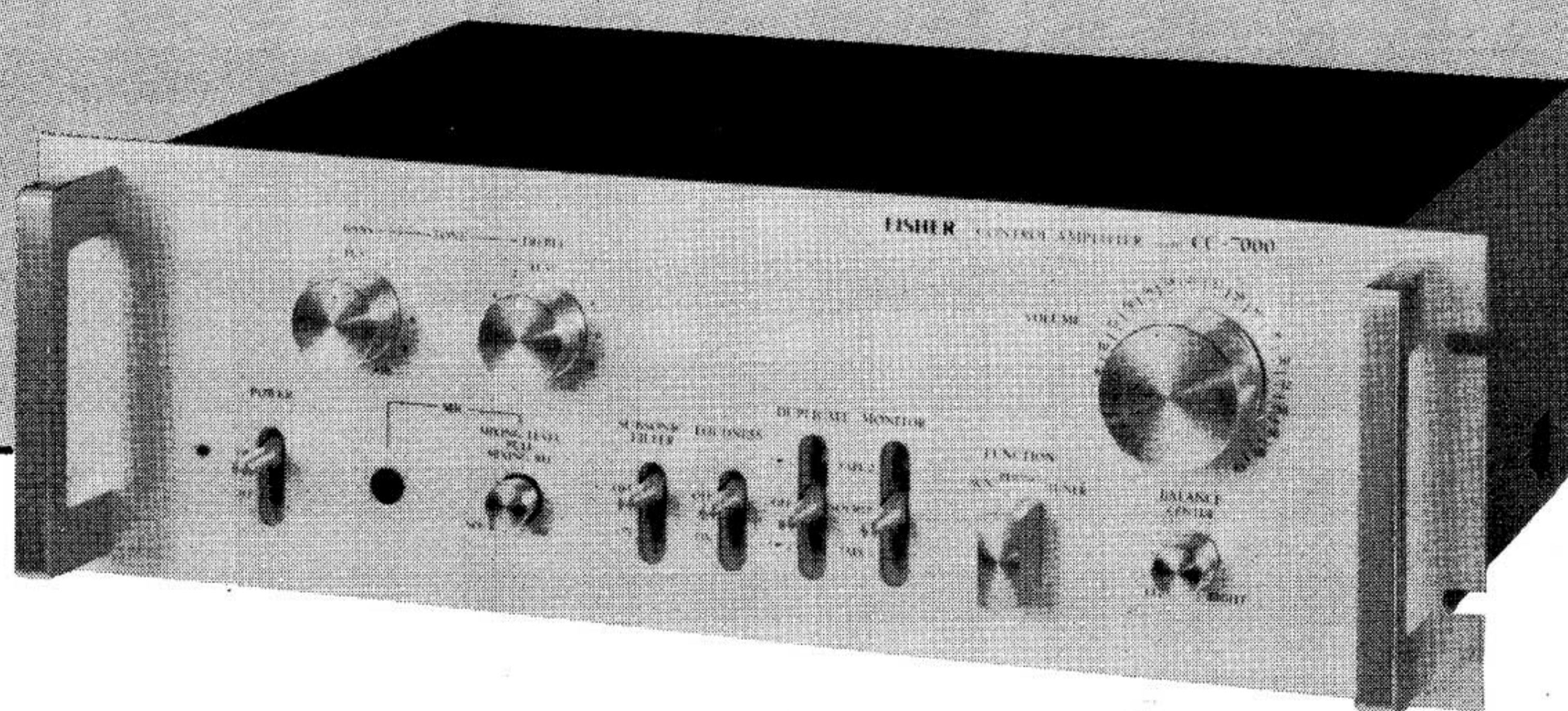

The first name in high fidelity

Nominal Specifications For Information Only.

CONTROL AMPLIFIER		CC-7000
PRE AMPLIFIER SECTION		
Input Sensitivity and Impedance	Phono	2.7 mV/50k ohm
	Tuner	150 mV/45k ohm
	Auxiliary	150 mV/45k ohm
	Tape PB (Tape 1 & 2)	150 mV/45k ohm
	Mic (Impedance:600 ohms)	2 mV
Output Level/Impedance	Output	1 V/1k ohm
	Rec (Tape 1 & 2)	150 mV
Phono Max. Rated Input		180 mV (1 kHz RMS)
RIAA Deviation		±0,5 dB
Frequency Response		10 Hz - 30 kHz (-2 dB)
Residual Noise		Less Than 0.1 mV
Signal to Noise Ratio	Phono	70 dB (IHF A network)
	Tuner	100 dB (IHF A network)
	Auxiliary	100 dB (IHF A network)
Tone Control	Bass	±9 dB (100 Hz)
	Treble	±8 dB (10 kHz)
Subsonic Filter		50 Hz (-6 dB/Oct.)
Loudness Control		+9 dB(100 Hz), +5 dB(10 kHz)
GENERAL		
Power Source		AC 110 V/220 V, 50 Hz
Power Consumption		8 W
Dimensions (W x H x D)		450 x 135 x 265 mm
Weight		4.5 kg (approx.)

Because Fisher products are subject to continuous improvement, Fisher reserves the right to modify, change, or alter any design or specifications without notice and without incurring any obligation. Fisher reserves the right to make changes and improvements upon its products without any obligation to install such changes upon any of its products previously manufactured.

PRINTED CIRCUIT BOARD WIRING DIAGRAM

(BOTTOM VIEW)



MIC LEVER SW. P.C.B. ASS'Y
1310-4001-83000

TAPE OUTPUT JACK P.C.B. ASS'Y
1310-4001-83300

VR P.C. ASS'Y
1310-4001-83100

INPUT JACK P.C.B. ASS'Y
1310-4001-83200

EQ, TONE, POWER SUPPLY P.C.B. ASS'Y
1310-4001-82900

SCHEMATIC DIAGRAM

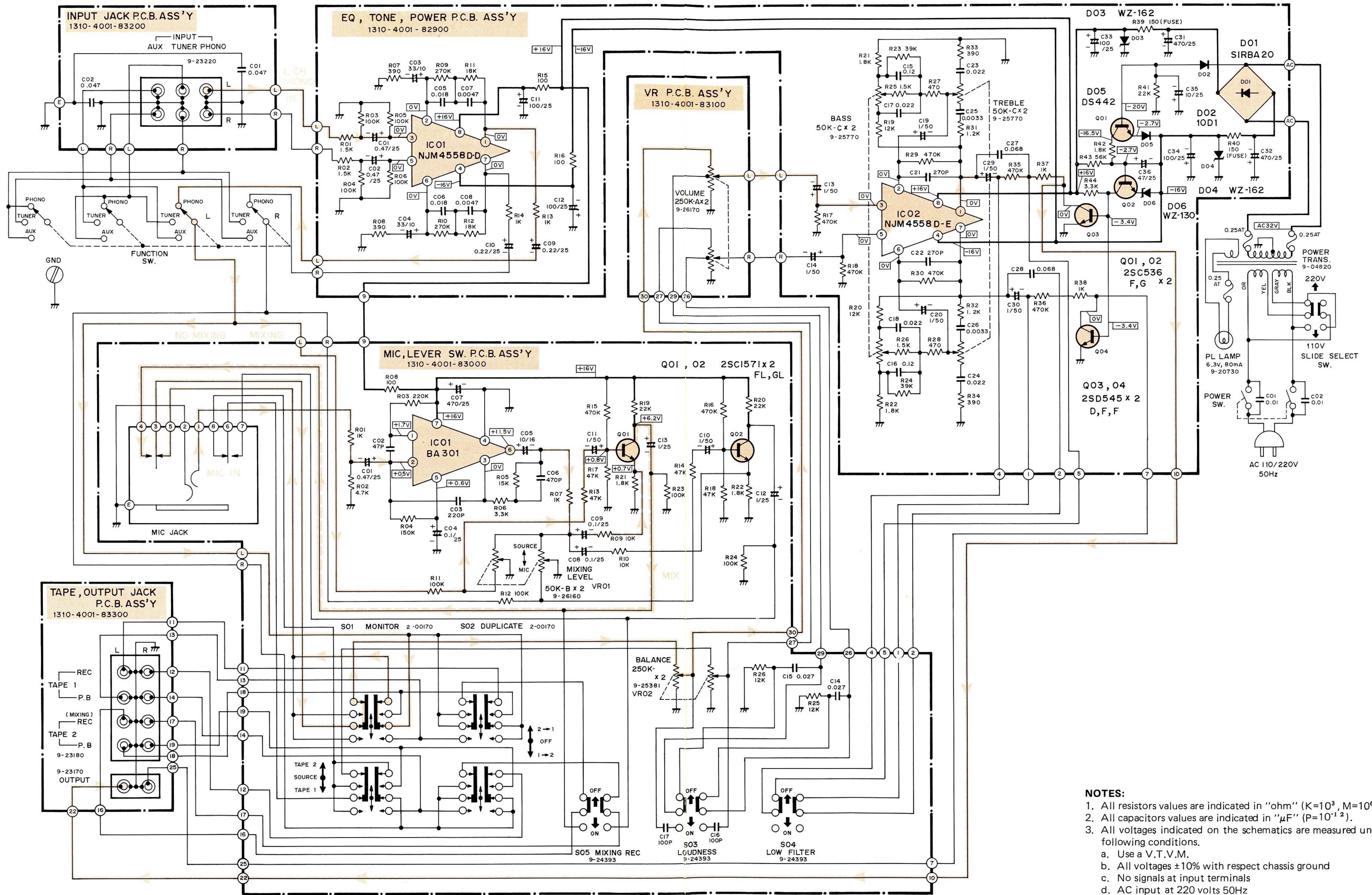

- NOTES:**
1. All resistors values are indicated in "ohm" ($K=10^3$, $M=10^6$).
 2. All capacitors values are indicated in " μF " ($P=10^{-12}$).
 3. All voltages indicated on the schematics are measured under the following conditions.
 - a. Use a V.T.V.M.
 - b. All voltages $\pm 10\%$ with respect chassis ground
 - c. No signals at input terminals
 - d. AC input at 220 volts 50Hz
 4. This is a fundamental schematics diagram. Some products may be modified without notice.

EXPLODED VIEW OF CABINET AND CHASSIS

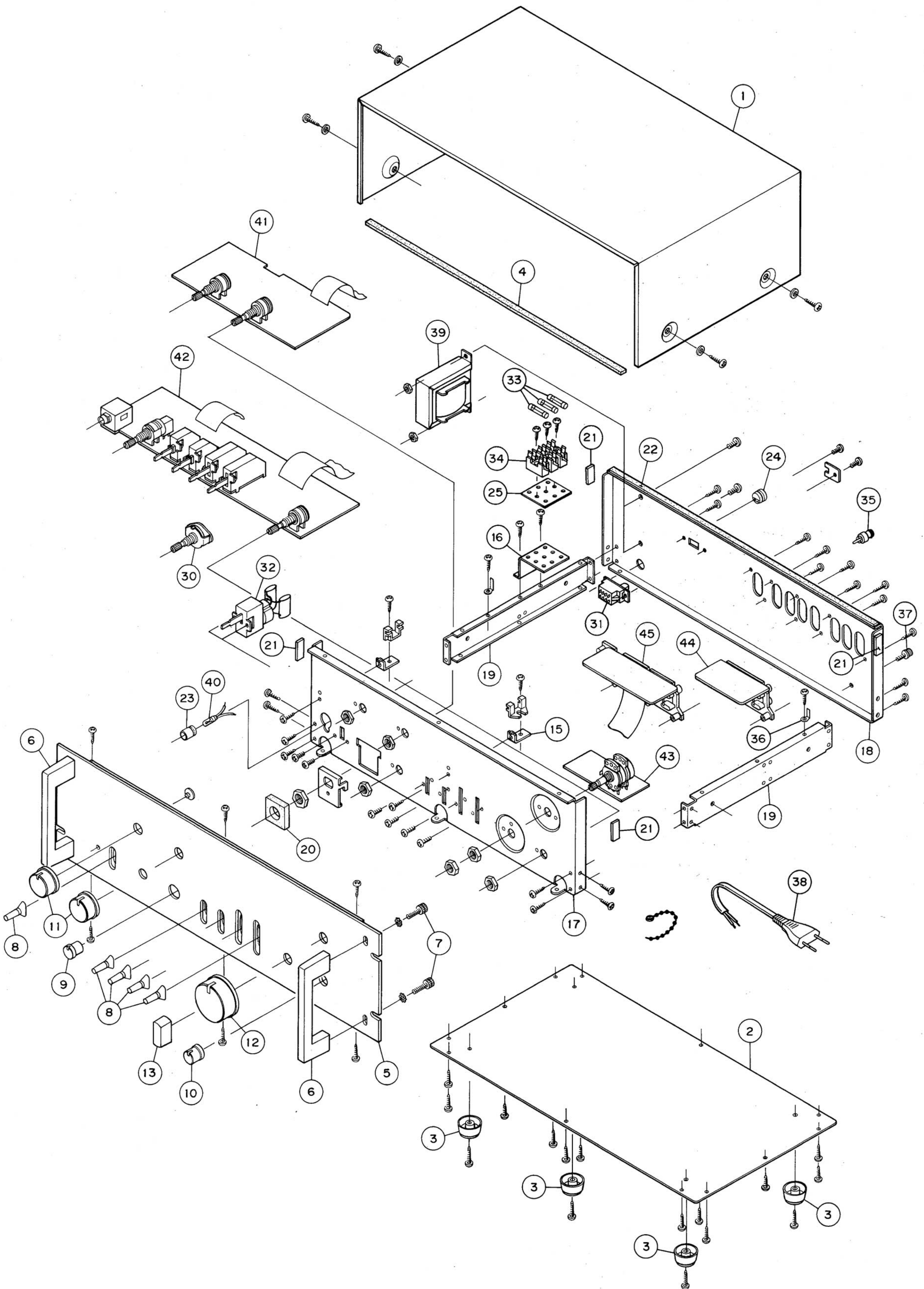

PARTS LIST

PACKING PARTS LIST

Ref. No.	Parts Number	Description
	131 6 1139 63805	Box Corrugate-EXP
	131 6 2119 01441	Bag Polyethylene-EXP (Set)
	131 6 3009 23580	Pad (Bottom, Top)

ACCESSORIES PARTS LIST

Ref. No.	Parts Number	Description
	131 6 4119 68700	Explanatory Booklet (English, French, German)
	131 6 4519 14700	Guarantee Certificate

CABINET PARTS LIST

Ref. No.	Parts Number	Description
1	131 2 1410 16500	Cover
2	131 2 1105 20400	Plate Bottom
3	131 2 1801 14100	Leg
4 *	131 2 5205 15300	Cushion

APPEARANCE PARTS LIST

Ref. No.	Parts Number	Description
5	131 0 1016 27701	Panel Decorative Assy
6	131 2 1701 12200	Handle
7	131 2 4201 18600	Screw (Handle)
8	131 0 1001 37601	Knob (Lever SW)
9	131 0 1001 42100	Knob (MIC)
10	131 0 1001 42200	Knob (BALANCE)
11	131 0 1001 42300	Knob (BASS, TREBLE)
12	131 0 1001 42400	Knob (MAIN VR)
13	131 0 1001 42500	Knob (FUNCTION)

CHASSIS PARTS LIST

Ref. No.	Parts Number	Description
15 *	131 2 3101 49500	Metal Mount
16 *	131 2 3101 54100	Metal Mount
17 *	131 2 3305 22500	Panel Front
18 *	131 2 3306 25001	Panel Rear
19 *	131 2 3308 12800	Chassis Sub
20 *	131 2 4208 20400	Spacer (Jack)
21 *	131 2 4208 26600	Spacer
22 *	131 2 5205 15300	Cushion (Panel Rear)
23	131 2 6111 11601	Housing (Power Ind.)
24	131 2 6111 14200	Bushing (AC Cord)
25 *	131 2 7103 30900	Label (Fuse)

ELECTRICAL PARTS LIST

Ref. No.	Parts Number	Description
30	4 2312 00400	SW Rotary, Function
31	4 2319 21531	Switch Slide 6P, 110 - 220V Select
32	4 2319 24382	SW Lever 4P, Power SW
33	4 2349 21320	Fuse 0.25 AT
34	4 2359 21021	Fuse Holder, AC Fuse
35	4 2369 20561	Short Plug RCA, Pin Jack
36	4 2379 21520	Terminal Lug 1P
37	4 2379 21650	Terminal 1P, Rear Panel
38 *	4 2439 20521	Power Cord
39	4 2512 04820	Power Transformer 110V/220V
40	4 6129 20730	Small Lamp 6.3V 80mA
C01,02	C2EHRM103A	MP Con. 0.01 μ F 250V \pm 20%
C03	C1HYDZ473A	Ceramic 0.047 μ F 50V +80,-20%
41 *	131 0 4001 82900	EQ, Tone, Power Supply P.C.B. Assy
42 *	131 0 4001 83000	Mic, Lever SW, P.C.B. Assy
43 *	131 0 4001 83100	VR P.C.B. Assy
44 *	131 0 4001 83200	Input Jack P.C.B. Assy
45 *	131 0 4001 83300	Tape Jack P.C.B. Assy

* -Not a service part.

EQ, TONE, POWER SUPPLY P.C.B. Assy 1310 4001 82900

Ref. No.	Parts Number	Description
VR01,02	4 2229 25770	VR 50k-C, BASS, TREBLE

CAPACITORS

C01,02	C1EUBM474A	Sint. Alu. 0.47 μ F 25V \pm 20%
C03,04	C1ARB-336A	Electrolytic 33 μ F 10V
C05,06	C1HFAK183A	Mylar 0.018 μ F 50V \pm 10%
C07,08	C1HFAK472A	Mylar 0.0047 μ F 50V \pm 10%
C09,10	C1EUBM224A	Sint. Alu. 0.22 μ F 25V \pm 20%
C11,12	C1ERB-107A	Electrolytic 100 μ F 25V
C13,14	C1HRB-105A	Electrolytic 1 μ F 50V
C15,16	C1HFAK124A	Mylar 0.12 μ F 50V \pm 10%
C17,18	C1HFAK223A	Mylar 0.022 μ F 50V \pm 10%
C19,20	C1HRB-105A	Electrolytic 1 μ F 50V
C21,22	C1HCSK271SL	Ceramic 270 pF 50V \pm 10%
C23,24	C1HFAK223A	Mylar 0.022 μ F 50V \pm 10%
C25,26	C1HFAK332A	Mylar 0.0033 μ F 50V \pm 10%
C27,28	C1HFAK683A	Mylar 0.068 μ F 50V \pm 10%
C29,30	C1HRB-105A	Electrolytic 1 μ F 50V
C31,32	C1ERB-477A	Electrolytic 470 μ F 25V
C33,34	C1ERB-107A	Electrolytic 100 μ F 25V
C35	C1ERB-106A	Electrolytic 10 μ F 25V
C36	C1ERB-476A	Electrolytic 47 μ F 25V

SEMICONDUCTORS

D01	DDD-S1RBA20	Diode Bridge S1RBA20
D02	DCC-10D1----NA	Diode, 10D1
D03,04	DJZ-WZ162	Zener Diode WZ-162
D05	205 5 9040 44210	Diode, DS-442
D06	DJJ-WZ-130	Diode WZ-130
IC01	IJJ-NJM4558D-D	IC, NJM4558D-D
IC02	IJJ-NJM4558D-E	IC, NJM4558D-E
Q01,02	203 5 5000 53660	TR 2SC536 F,G
Q03,04	203 5 6870 54540	TR 2SD545 D,E,F

PARTS LIST

Ref. No.	Parts Number	Description
RESISTORS		
R01,02	R2EDSJ152A	Carbon 1.5k 1/4W ±5%
R03,04 05,06	R2EDSJ104A	Carbon 100k 1/4W ±5%
R07,08	R2EDSJ391A	Carbon 390 1/4W ±5%
R09,10	R2EDSJ274A	Carbon 270k 1/4W ±5%
R11,12	R2EDSJ183A	Carbon 18k 1/4W ±5%
R13,14	R2EDSJ102A	Carbon 1k 1/4W ±5%
R15,16	R2EDSJ101A	Carbon 100 1/4W ±5%
R17,18	R2EDSJ474A	Carbon 470k 1/4W ±5%
R19,20	R2EDSJ123A	Carbon 12k 1/4W ±5%
R21,22	R2EDSJ182A	Carbon 1.8k 1/4W ±5%
R23,24	R2EDSJ393A	Carbon 39k 1/4W ±5%
R25,26	R2EDSJ152A	Carbon 1.5k 1/4W ±5%
R27,28	R2EDSJ471A	Carbon 470 1/4W ±5%
R29,30	R2EDSJ474A	Carbon 470k 1/4W ±5%
R31,32	R2EDSJ122A	Carbon 1.2k 1/4W ±5%
R33,34	R2EDSJ391A	Carbon 390 1/4W ±5%
R35,36	R2EDSJ474A	Carbon 470k 1/4W ±5%
R37,38	R2EDSJ102A	Carbon 1k 1/4W ±5%
R39,40	R2HZPK151A	Fuse 150 1/2W ±10%
R41	R2EDSJ223A	Carbon 22k 1/4W ±5%
R42	R2EDSJ182A	Carbon 1.8k 1/4W ±5%
R43	R2EDSJ563A	Carbon 56k 1/4W ±5%
R44	R2EDSJ332A	Carbon 3.3k 1/4W ±5%

MIC, LEVER SW, P.C.B. Assy 1310 4001 83000

Ref. No.	Parts Number	Description
	4 2359 23210	Mic Jack
SW01,02	4 2312 00170	SW Lever 16P
SW03,04	4 2319 24393	SW Lever 6P
VR01,SW05	4 2229 26160	VR 50k-Bx2 MIXING REC.
VR02	4 2229 25381	VR 250kx2 BALANCE

CAPACITORS

C01	C1EUBM474A	Sint. Alu. 0.47 μF 25V ±20%
C02	C1HCSK470SL	Ceramic 47 pF 50V ±10%
C03	C1HCSK221SL	Ceramic 220 pF 50V ±10%
C04	C1EUBM104A	Sint. Alu. 0.1 μF 25V ±20%
C05	C1CRB-106A	Electrolytic 10 μF 16V
C06	C1HCSK471SL	Ceramic 470 pF 50V ±10%
C07	C1ERB-477A	Electrolytic 470 μF 25V
C08,09	C1EUBM104A	Sint. Alu. 0.1 μF 25V ±20%
C10,11	C1HRB-105A	Electrolytic 1 μF 50V
C12,13	C1EUBM105A	Sint. Alu. 1 μF 25V ±20%
C14,15	C1HFAK273A	Mylar 0.027 μF 50V ±10%
C16,17	C1HCSK101SL	Ceramic 100 pF 50V ±10%

SEMICONDUCTORS

IC01	IYY-BA301	IC BA301
Q01,02	203 5 5251 57169	TR 2SC1571FL GL

Ref. No.	Parts Number	Description
RESISTORS		
R01	R2EDSJ102A	Carbon 1k 1/4W ±5%
R02	R2EDSJ472A	Carbon 4.7k 1/4W ±5%
R03	R2EDSJ224A	Carbon 220k 1/4W ±5%
R04	R2EDSJ154A	Carbon 150k 1/4W ±5%
R05	R2EDSJ153A	Carbon 15k 1/4W ±5%
R06	R2EDSJ332A	Carbon 3.3k 1/4W ±5%
R07	R2EDSJ102A	Carbon 1k 1/4W ±5%
R08	R2EDSJ101A	Carbon 100 1/4W ±5%
R09,10	R2EDSJ103A	Carbon 10k 1/4W ±5%
R11,12	R2EDSJ104A	Carbon 100k 1/4W ±5%
R13,14	R2EDSJ473A	Carbon 47k 1/4W ±5%
R15,16	R2EDSJ474A	Carbon 470k 1/4W ±5%
R17,18	R2EDSJ473A	Carbon 47k 1/4W ±5%
R19,20	R2EDSJ223A	Carbon 22k 1/4W ±5%
R21,22	R2EDSJ182A	Carbon 1.8k 1/4W ±5%
R23,24	R2EDSJ104A	Carbon 100k 1/4W ±5%
R25,26	R2EDSJ123A	Carbon 12k 1/4W ±5%

VOLUME P.C.B. Assy 1310 4001 83100

Ref. No.	Parts Number	Description
VR01	4 2229 26170	VR 250k-Ax2

INPUT JACK P.C.B. Assy 1310 4001 83200

Ref. No.	Parts Number	Description
	4 2359 23220	RCA 6P Jack
C01,02	C1HYSZ473A	Ceramic 0.047 μF 50V +80,-20%

TAPE JACK P.C.B. Assy 1310 4001 83300

Ref. No.	Parts Number	Description
	4 2359 23170	Socket 2P
	4 2359 23180	Socket 4P

FUNCTIONAL BLOCK DIAGRAM

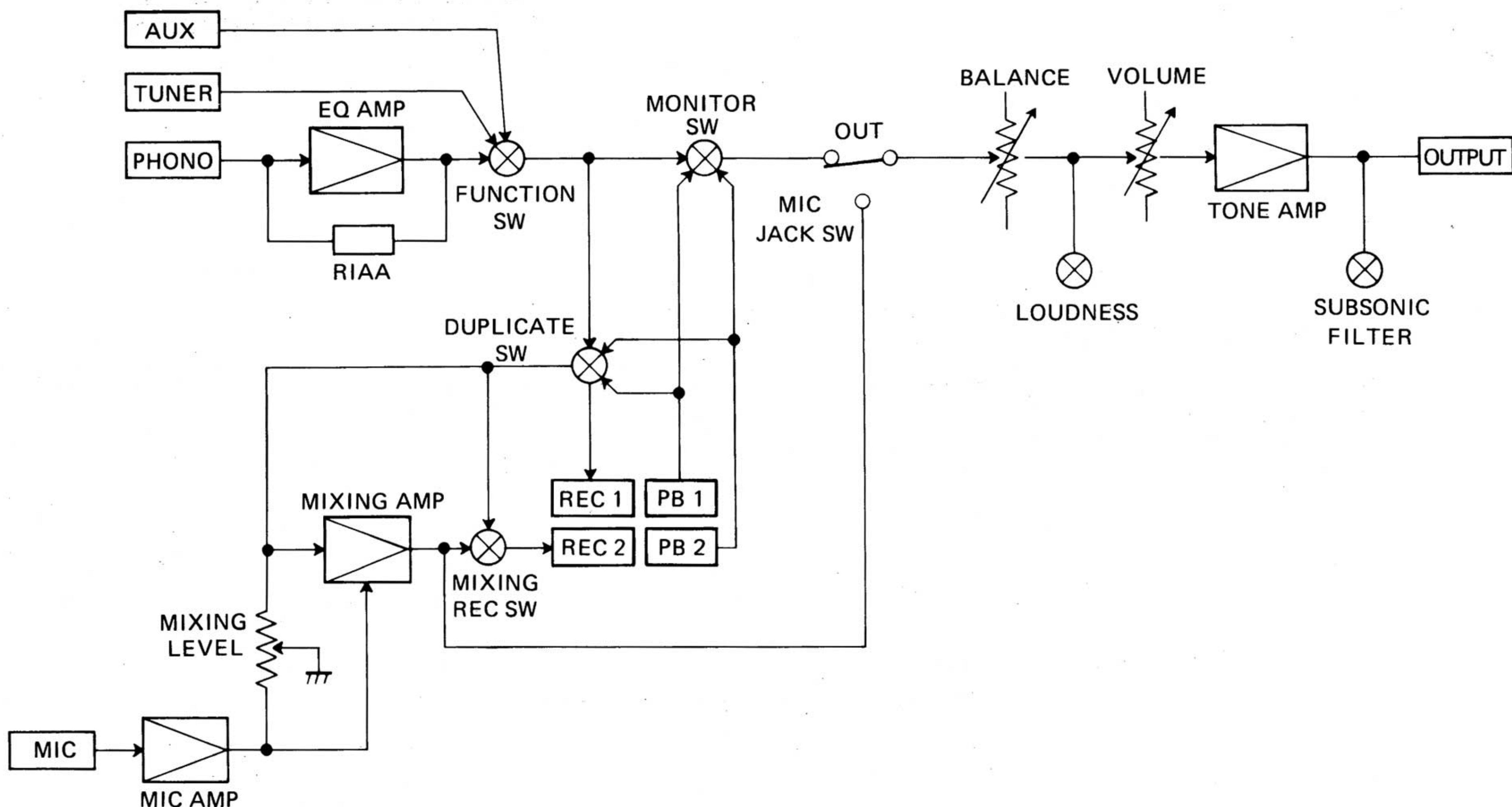

EQ AMP IC NJM4558D EQUIVALENT CIRCUIT

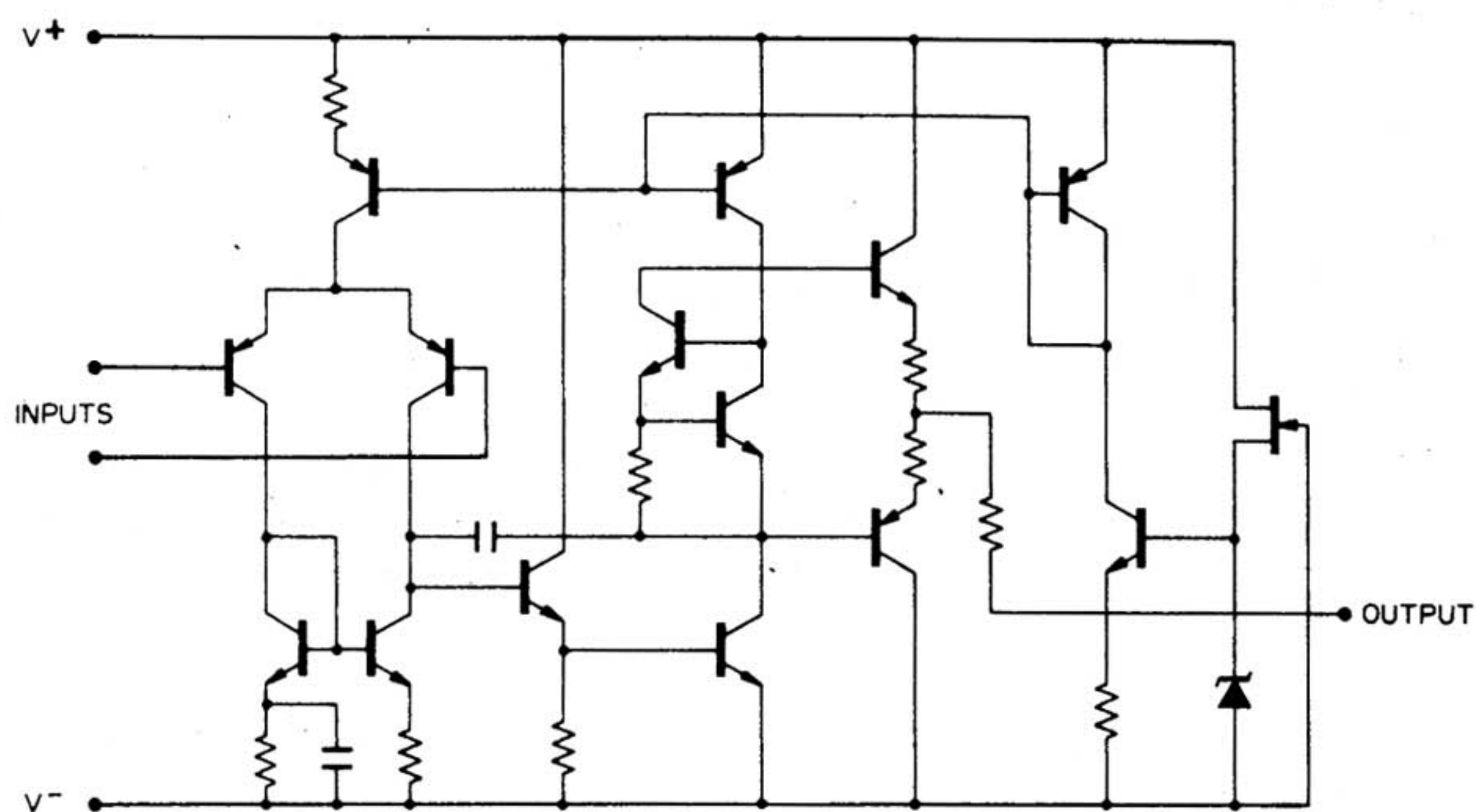
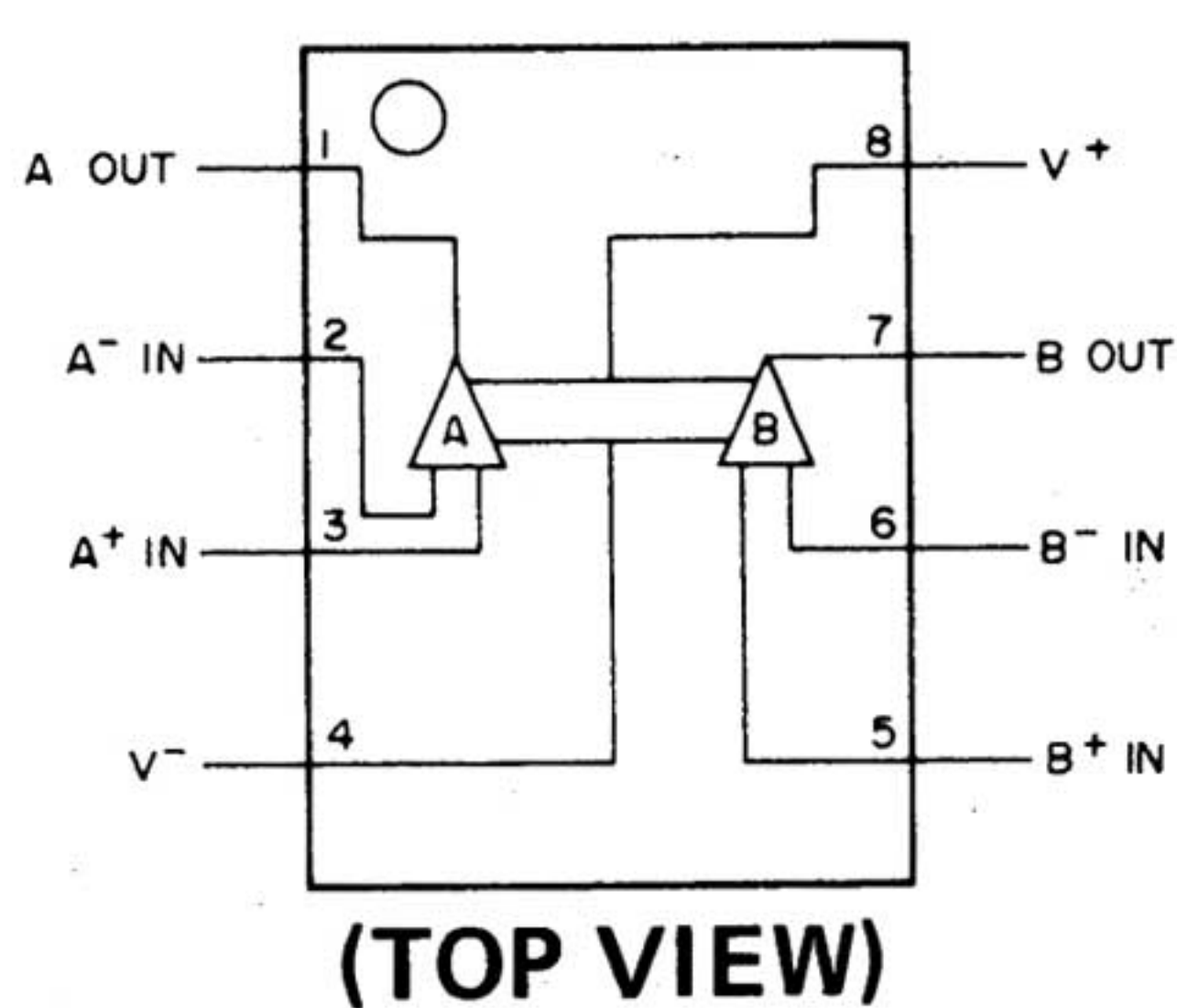

MIC AMP IC BA301 EQUIVALENT CIRCUIT

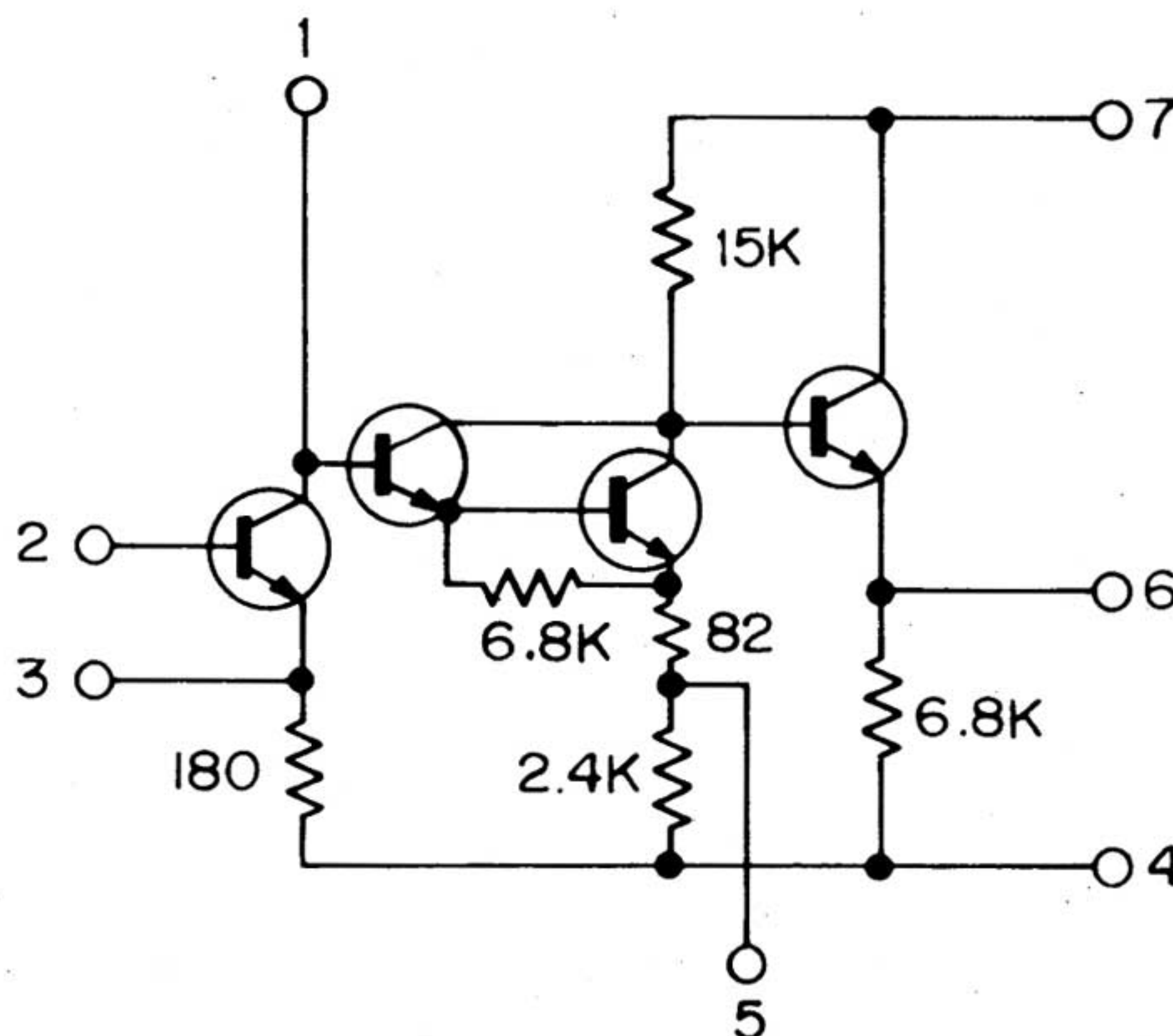
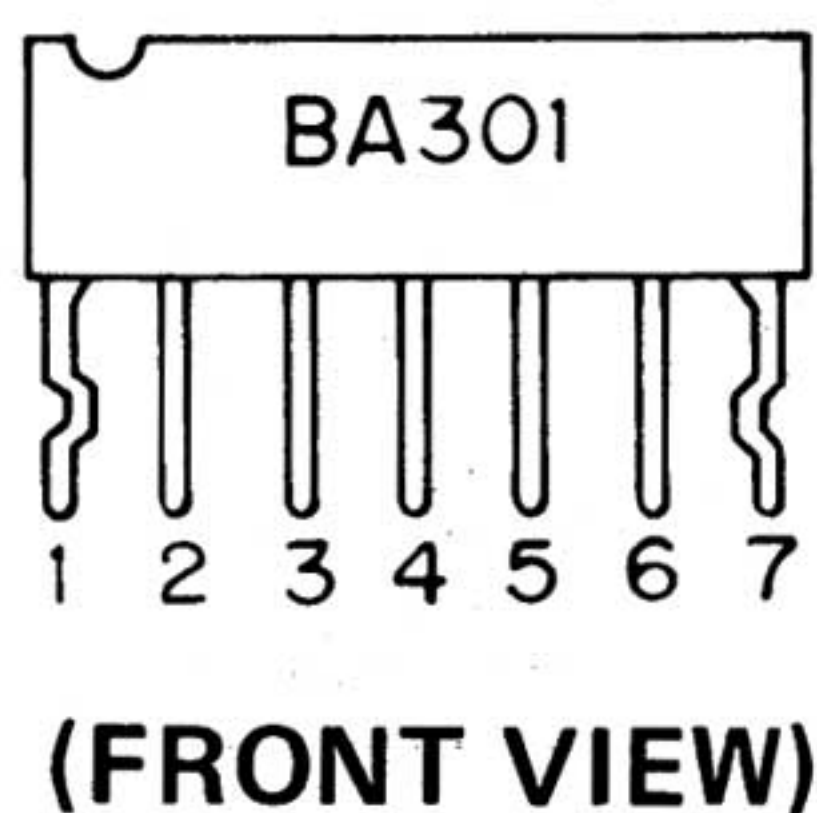

NOTES



FISHER

Service und Auslieferungslager:
FISHER HiFi Europa, Vertriebs-GmbH
Schönstraße 80, 8000 München 90
Telefon 089/652011

Wenden Sie sich bitte mit technischen
Fragen an diese Adresse

Verwaltung und Verkauf:
FISHER HiFi Europa, Vertriebs-GmbH
Widenmayerstraße 25, 8000 München 22
Telefon 089/224851, Telex 5-24033 D

PRINTED IN JAPAN
78/Jan. **WM-2896**