

SERVICE MANUAL



FISHER

CR-W560

(EUROPE)

Stereo Double Cassette Deck



142 501 38

SPECIFICATIONS

Motor	DC Governor
Cassette Loading	(2) Front
Drive System	(2) Capstan
Number of Heads	3
Head Material	Permalloy/Ferrite
Operation	(2) Mechanical
Dubbing	Normal/High Speed
Wow & Flutter	0.13% WRMS
Signal-to-Noise Ratio (CCIR Weighted)	
Dolby NR OFF	51dB
Dolby NR ON	61dB
(Dolby is registered trademark of Dolby Laboratories.)	
Erase Ratio	70dB
Channel Separation	40dB
Signal Crosstalk	70dB
Frequency Response 1-7/8 Ips.	
Normal Tape (± 3 dB)	50Hz ~ 13kHz
CrO ₂ Equivalent Tape (± 3 dB)	50Hz ~ 14kHz
Metal Tape (± 3 dB)	50Hz ~ 15kHz

Total Harmonic Distortion	
at 0 VU	1.5%
Fast Forward/Rewind Time	
(C-60)	110sec.
Peak Level Indicators	2 5-segment L.E.D. indicators
Inputs (Sensitivity/Impedance)	(2) Line
	100mV/50k Ω
Outputs (Level at 0 VU/Impedance)	(2) Line
	500mV/2.2k Ω
Headphones	35mV/8 Ω
Tape Selector Switch	
DECK 1	Auto Tape Selector
DECK 2	Normal, CrO ₂ , Metal
Tape Counter	3-Digit

GENERAL

Power Requirements (50Hz)	AC 220V
Power Consumption	15Watts
Dimensions (WxHxD)	440 x 145 x 280mm
Weight (approx)	4.0kg

SCHEMATIC DIAGRAM

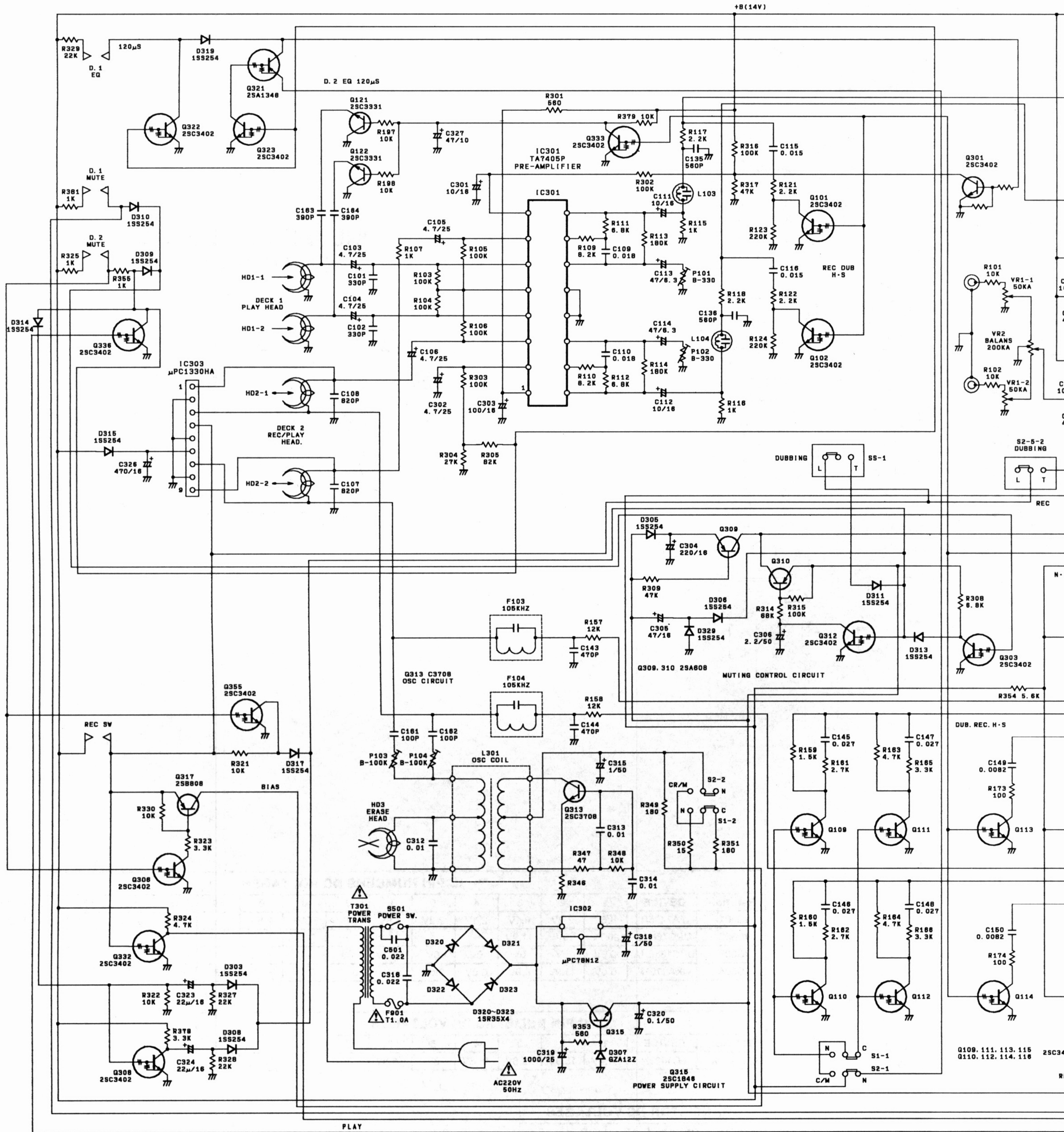

- S1-1-S1-2 --- R/P SW. --- PLAY
- S1-1-S1-2 --- METAL/CR02 SW. --- } NORMAL
- S2-1-S2-2 --- M. C/NORMAL SW. --- } NORMAL
- S3-1-S3-2 --- DOLBY SW. --- OFF
- S4 --- H-SPEED SW. --- OFF(NORMAL SPEED)
- S5-1-S5-2 --- DUBBING SW. --- OFF(LINE)

DIAGRAM

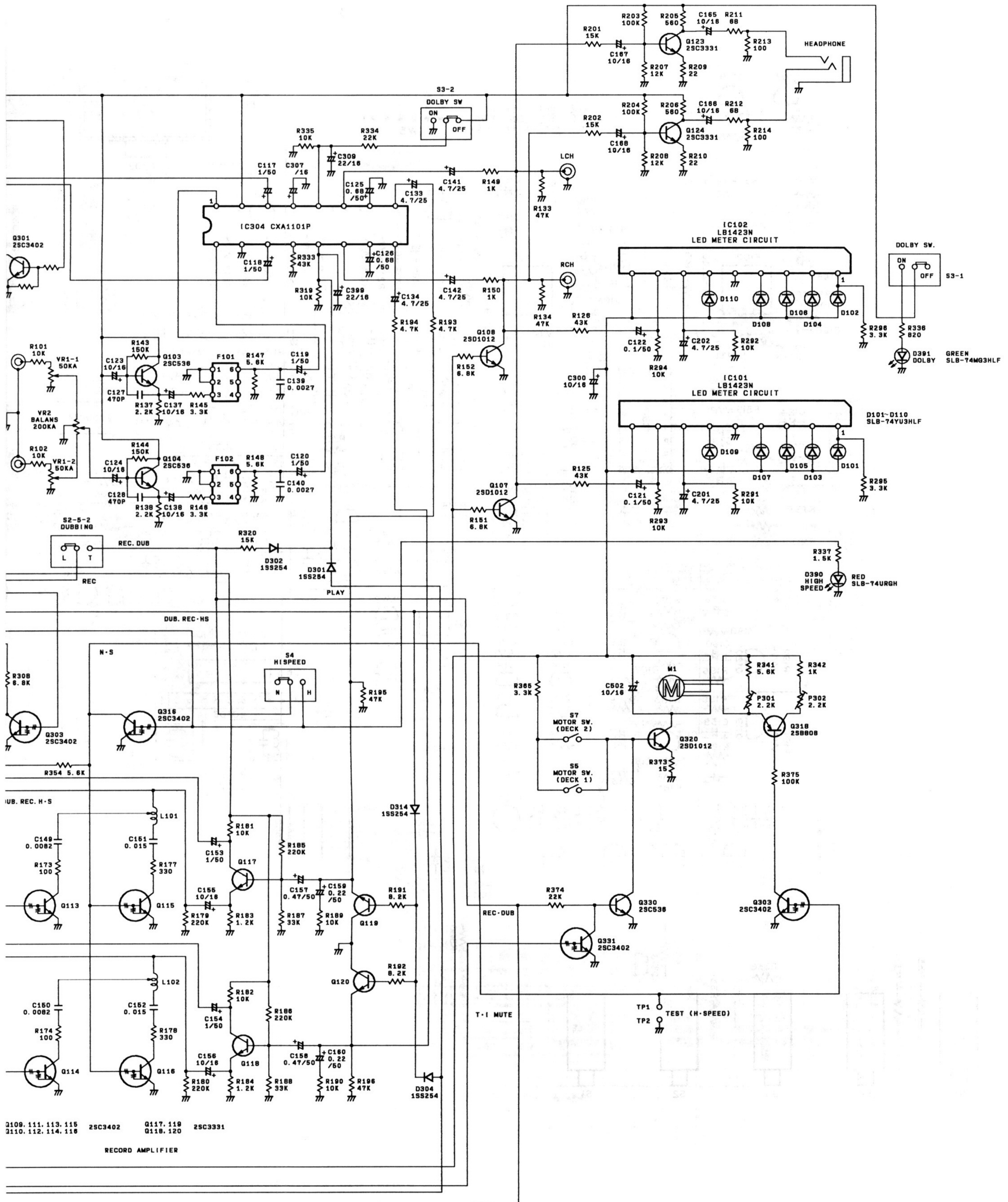

WIRING DIAGRAM

