

SERVICE MANUAL



FISHER

STEREO DOUBLE CASSETTE DECK

CR-W9025

(EUROPE)



142 500 19

SPECIFICATIONS

Motor	(2) DC Governor	Total Harmonic Distortion at 0 VU	1.5%
Cassette Loading	(2) Front	Fast Forward/Rewind Time (C-60)	110sec.
Drive System	(2) Capstan	Level Indicators	(2) L.E.D. Meter
Number of Heads	3	Inputs (Sensitivity/Impedance)	(2) Line 100mV/50k Ω
Head Material	Permalloy/Ferrite	Outputs (Level at 0 VU/Impedance)	(2) Line 500mV/2.2k Ω
Operation	(2) Full Logic Mechanism	Auto Tape Select	Normal, CrO ₂ , Metal
Dubbing	Normal/High Speed	Tape Counter	3-Digit
Wow & Flutter	0.06% WRMS	GENERAL	
Signal-to-Noise Ratio (CCIR Weighted)		Power Requirements (50Hz)	AC 220V
Dolby NR OFF	52dB	Power Consumption	26Watts
Dolby NR ON	62dB	Dimensions (WxHxD)	440x132x278mm
(Dolby is registered trademark of Dolby Laboratories.)		Weight (approx)	5.2kg
Erase Ratio	70dB		
Channel Separation	40dB		
Signal Crosstalk	70dB		
Frequency Response 1-7/8 Ips.			
Normal Tape (± 3 dB)	40Hz ~ 13kHz		
CrO ₂ Equivalent Tape (± 3 dB)	40Hz ~ 14kHz		
Metal Tape (± 3 dB)	40Hz ~ 15kHz		

— Specifications and design are subject to change without notice. —

REFERENCE No. WM-570560

SCHEMATIC DIAGRAM (Amplifier)

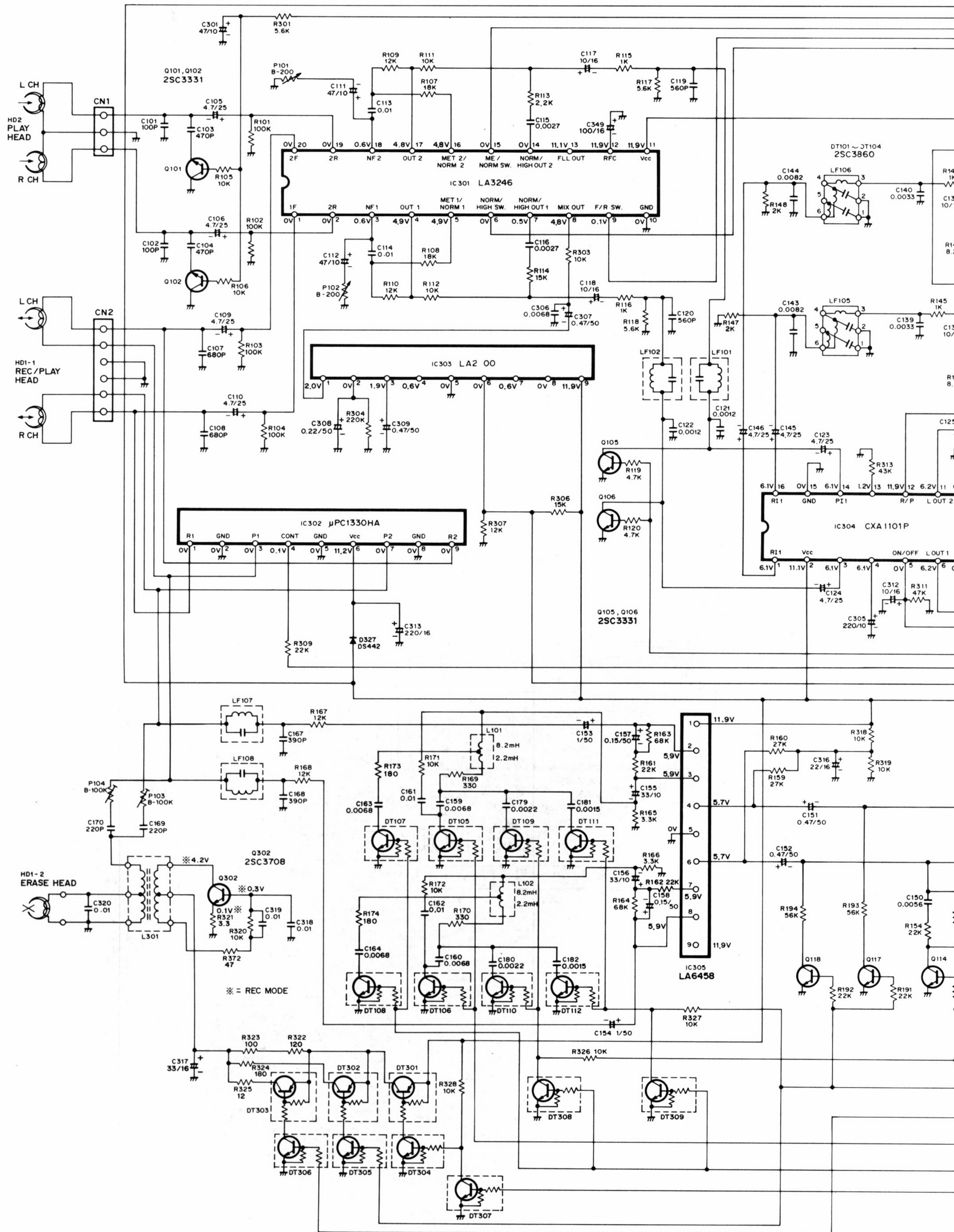

DT301, DT303 2SA1524 DT105 ~ DT112 2SC3402
 DT302 2SA1503 DT304 ~ DT309 2SC3402

M (Amplifier Section)

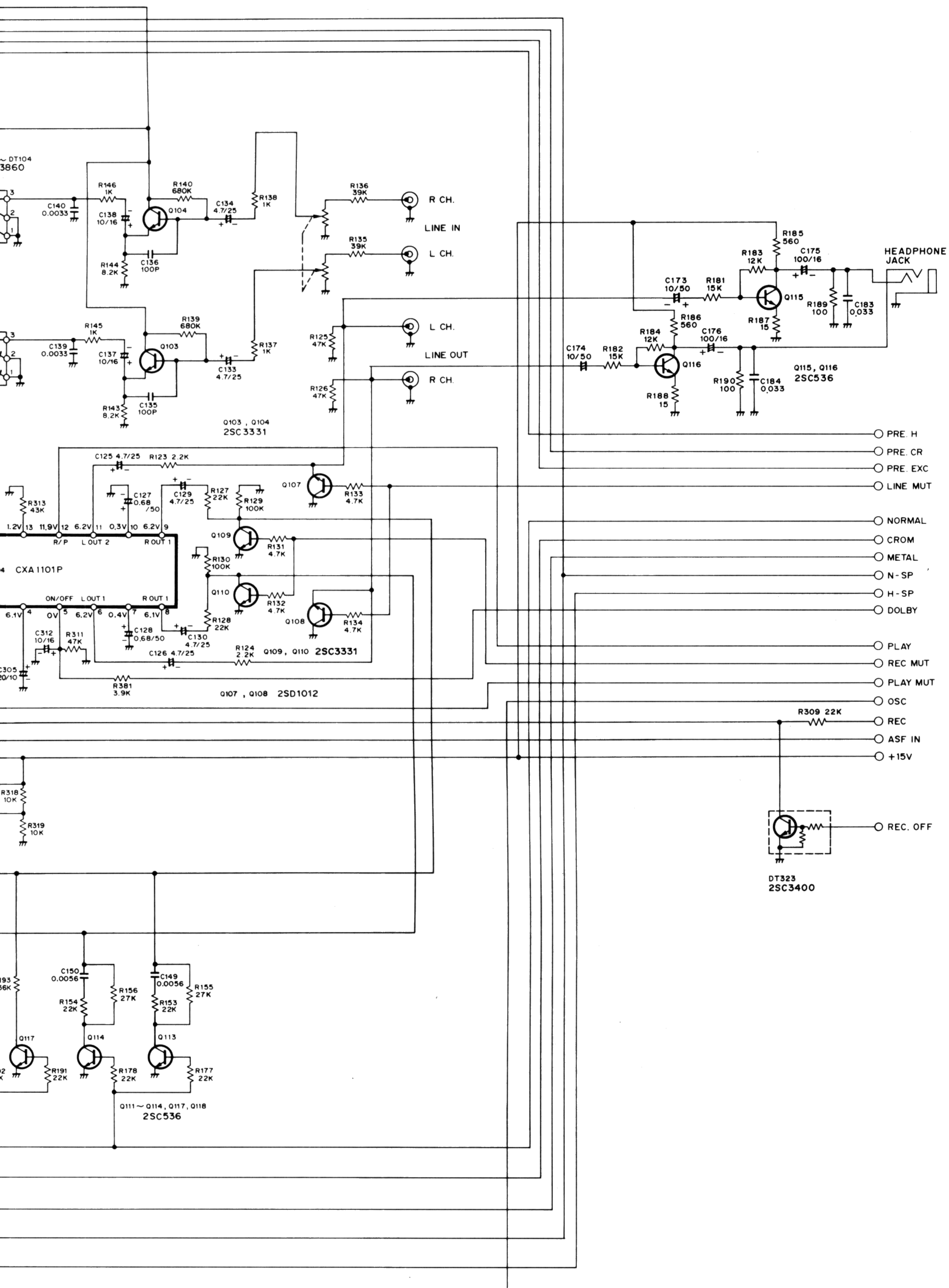

SCHEMATIC DIAGRAM

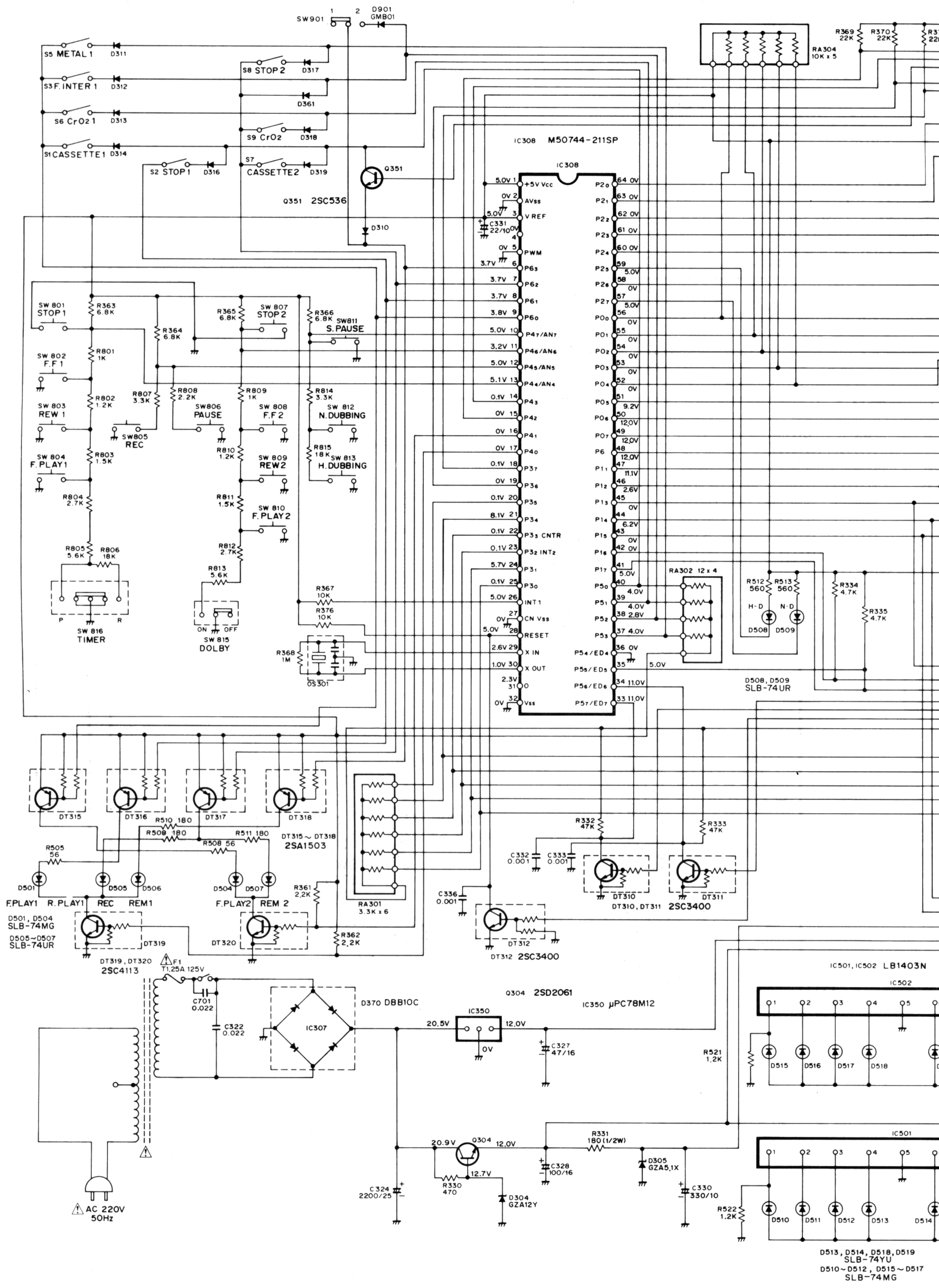

D513, D514, D518, D519
SLB-74YU
D510~D512, D515~D517
SLB-74MG

DIAGRAM (Control Section)

