

Stereophonic

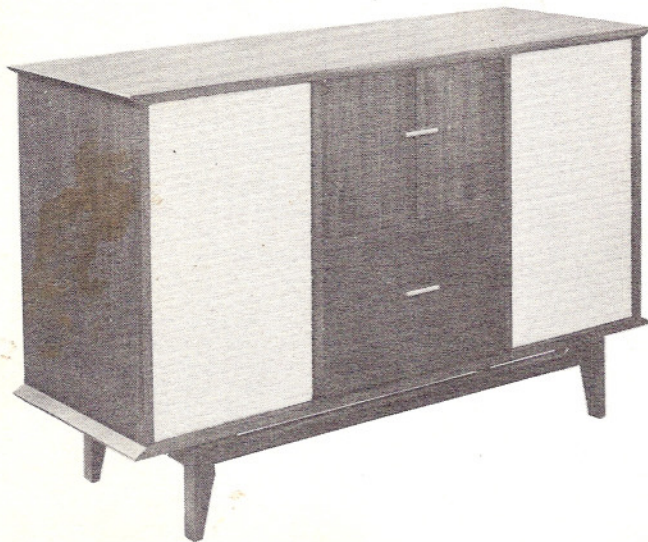

THE FISHER
CORONET
SERVICE
MANUAL



MODEL 808

CHASSIS SERIAL NUMBERS
FROM 10001 TO 29999 INCLUSIVE

PRICE: \$1.00

FISHER RADIO CORPORATION • NEW YORK



CHASSIS SERIAL NUMBERS
FROM 10001 TO 29999 INCLUSIVE

THE FISHER 808



PARTS DESCRIPTION LIST • TUNERS AND PREAMPLIFIER

CAPACITORS

10% tolerance for all fixed capacitors, unless otherwise noted or marked. GMV (guaranteed minimum value.)

| Symbol | Description | Part No. |
|----------------|---|-------------|
| C1 | Ceramic, 24uf 5% N150, 1000V | C50070-8 |
| C2 | Ceramic, 8uf ± .5uf NPO, 500V | CC20CJ080D5 |
| C3 | not used | |
| C4 | Ceramic, 100uf N1500, 1000V | C50070-6 |
| C5 | Ceramic, Trimmer | C662-123 |
| C6 | FM Variable | C726-116 |
| C7 | AM Variable | C684-127 |
| C8, 9 | Ceramic, 100uf, N1500, 1000V | C50070-6 |
| C10 | Ceramic, Feedthru, .001uf GMV | C592-187 |
| C11 | Ceramic, .02uf + 80 — 20%, 500V | C50089-4 |
| C12 | Ceramic, Feedthru, .001uf GMV | C592-187 |
| C13 | Ceramic, .02uf + 80 — 20%, 500V | C50089-4 |
| C14 | Ceramic, 18uf, N470, 1000V | C50070-13 |
| C15 | Ceramic, Feedthru, .001uf GMV | C592-187 |
| C16 | Ceramic, .001uf, 1000V | C50072-3 |
| C17 | Ceramic, .68uf, 500V | C50077-6N |
| C18 | Ceramic, Feedthru, .001uf GMV | C592-187 |
| C19 | Ceramic, 5uf ± .5uf NPO, 1000V | CC20CJ050D5 |
| C20 | not used | |
| C21 | Ceramic, .02uf + 80 — 20%, 500V | C50089-4 |
| C22 | Ceramic, Trimmer | C662-123 |
| C23 | Ceramic, 10uf ± .5uf NPO, 500V | CC20CJ100D5 |
| C24 | Ceramic, 100uf N1500, 1000V | C50070-6 |
| C25 | Ceramic, 2.2uf, 500V | C3039 |
| C26 | Ceramic, .02uf + 80 — 20%, 500V | C50089-4 |
| C27 | Ceramic, 68uf N750, 500V | CC20UJ680K5 |
| C28 | Ceramic, 100uf N1500, 1000V | C50070-6 |
| C29 | Ceramic, 5uf ± .5uf N150, 500V | CC20PJ050D5 |
| C30 | Ceramic, 47uf N750, 1000V | C50070-6 |
| C31 | Ceramic, 5uf ± .5uf N220, 500V | CC20RH050D5 |
| C32 | Ceramic, Trimmer | C662-123 |
| C33 | Ceramic, 100uf GMV, 1000V | C50070-5 |
| C34 | Ceramic, .02uf + 80 — 20%, 500V | C50089-4 |
| C35 | Ceramic, 24uf 5% N150, 1000V | C50070-8 |
| C36 | Ceramic, Feedthru .001uf GMV | C592-187 |
| C37 | Ceramic, 100uf 5%, N1500, 1000V | C50070-19 |
| C38 | Ceramic, 10uf ± .5uf NPO, 500V | CC20CJ100D5 |
| C39 | Ceramic, .001uf, 1000V | C50072-3 |
| C40 | Ceramic, .68uf, 500V | C50077-6N |
| C41 | Ceramic, .02uf + 80 — 20%, 500V | C50089-4 |
| C42 | Ceramic, Feedthru .001uf GMV | C592-187 |
| C43 | Ceramic, .02uf + 80 — 20%, 500V | C50089-4 |
| C44 | Ceramic, .005uf, 20%, 500V | C50089-1 |
| C45 | Ceramic, .0027uf, 20%, 1000V | C50071-5 |
| C46 | Ceramic, .005uf, 20%, 500V | C50089-1 |
| C47 | Ceramic, .02uf + 80 — 20%, 500V | C50089-4 |
| C48 | Ceramic, .005uf, 20%, 500V | C50089-1 |
| C49 | Ceramic, 900uf, 5%, 500V | CC21GP901J5 |
| C50 | Ceramic, .02uf + 80 — 20%, 500V | C50089-4 |
| C51 | Ceramic, .005uf, 20, 500V | C50089-1 |
| C52 | Ceramic, .05uf + 80 — 20%, 100V | C50073-2 |
| C53, 54 | Ceramic, .005uf, 20%, 500V | C50089-1 |
| C55 | Ceramic, .0027uf, 20%, 1000V | C50071-5 |
| C56 | Ceramic, 220uf, 1000V | C50072-20 |
| C57 | Ceramic, .02uf + 80 — 20%, 500V | C50089-4 |
| C58 | Ceramic, .0027uf, 20%, 1000V | C50071-5 |
| C59 | Ceramic, .005uf, 20%, 500V | C50089-1 |
| C60 | Mylar, .1uf, 400V | C50197-32 |
| C61 | Ceramic, 330uf, 1000V | C50072-1 |
| C62 | Molded, .0033uf, 5%, 200V | C68P332J2 |
| C63 | Ceramic, .005uf, 20%, 500V | C50089-1 |
| C64, 65 | Ceramic, 330uf, 1000V | C50072-1 |
| C66 | Electrolytic, 8uf, 50V | C629-138 |
| C67, 68 | Ceramic, 220uf, 1000V | C50072-20 |
| C69, 70 | Ceramic, 100uf, GMV N1500, 1000V | C50070-5 |
| C71, 72 | Ceramic, .01uf, 20%, 500V | C50089-3 |
| C73, 74 | Ceramic, .02uf, 20%, 500V | C50089-5 |
| C75, 76 | Ceramic, .05uf + 80 — 20%, 100V | C50073-2 |
| C77, 78 | Ceramic, 24uf, 5%, N150, 1000V | C50070-8 |
| C79, 80 | Ceramic, .02uf, 20%, 500V | C50089-5 |
| C81 | Ceramic, 220uf, 1000V | C50072-20 |
| C82 | Ceramic, .0033uf, 1000V | C50072-11 |
| C83 | Ceramic, 220uf, 1000V | C50072-20 |
| C84 | Ceramic, .0033uf, 1000V | C50072-11 |
| C85 | Ceramic, .001uf, 1000V | C50072-3 |
| C86 | Ceramic, .01uf 20%, 500V | C50089-3 |
| C87 | Ceramic, .001uf, 1000V | C50072-3 |
| C88 | Ceramic, .01uf, 20%, 500V | C50089-3 |
| C89, 90 | Ceramic, .05uf, + 80% — 20% 100V | C50073-2 |
| C91 | Ceramic, 47uf, N750, 1000V | C50070-4 |
| C92 | Ceramic, 68uf, N750, 1000V | C50070-16 |
| C93 | Ceramic, .0015uf, 1000V | C50072-10 |
| C94 | Ceramic, .0022uf, 1000V | C50072-5 |
| C95 | Ceramic, .0015uf, 1000V | C50072-10 |
| C96 | Ceramic, .0022uf, 1000V | C50072-5 |
| C97, 98 | Ceramic, .02uf, 20%, 500V | C50089-5 |
| C99, 100 | Ceramic, 47uf, N750, 1000V | C50070-4 |
| C101, 102 | Ceramic, .02uf, 20%, 500V | C50089-5 |
| C103 | Mylar, .1uf, 400V | C50197-32 |
| C104 | Ceramic, .02uf, 20%, 500V | C50089-5 |
| C105 | Ceramic, 82uf, N1500, 1000V | C50070-7 |
| C106 | Mylar, .1uf, 400V | C50197-32 |
| C107 | Ceramic, .02uf, 20%, 500V | C50089-5 |
| C108 | Ceramic, 82uf, N1500, 1000V | C50070-7 |
| C109 | Ceramic, .005uf, 20%, 500V | C50089-1 |
| C110 | Electrolytic, two section: A: 40uf, 250V B: 40uf, 250V | C50180-5 |
| C111 | Ceramic, .005uf, 20%, 500V | C50089-1 |
| C112 | Electrolytic, three section: A: 40uf, 300V B: 40uf, 250V C: 40uf, 250V | C670-125 |
| C113 | Electrolytic, two section: A: 500uf, 30V B: 500uf, 30V | C50180-6 |
| C114 | Ceramic, Feedthru, .001uf, GMV | C592-187 |
| C115, 116, 117 | Ceramic, .005uf, 20%, 500V | C50089-1 |
| C118, 119 | Molded, .01uf, 20%, 600V | C2747 |

RESISTORS AND POTENTIOMETERS

In ohms, 10% tolerance, 1/2 Watt, unless otherwise noted. K = Kilohm, M = Megohm.

| Symbol | Description | Part No. |
|--------|---------------------|------------|
| R1 | Composition, 270 | RC20BF271K |
| R2 | Composition, 1K | RC20BF102K |
| R3 | Composition, 4.7 | RC20BF47K |
| R4 | Composition, 820K | RC20BF824K |
| R5 | Composition, 100K | RC20BF104K |
| R6 | Composition, 100 | RC20BF101K |
| R7 | Composition, 47K | RC20BF473K |
| R8, 9 | Composition, 330K | RC20BF334K |
| R10 | Composition, 4.7 | RC20BF477K |
| R11 | Composition, 22 | RC20BF220K |
| R12 | Composition, 2.2K | RC20BF222K |
| R13 | Composition, 33K 1W | RC30BF333K |
| R14 | Composition, 220 | RC20BF221K |
| R15 | Composition, 47K | RC20BF473K |

| | | |
|---------|--|------------|
| R16 | Composition, 470K | RC20BF474K |
| R17 | Composition, 1K | RC20BF102K |
| R18 | Composition, 270 | RC20BF271K |
| R19 | Composition, 150 | RC20BF151K |
| R20 | Composition, 33K 1W | RC30BF333K |
| R21 | Composition, 270 | RC20BF271K |
| R22 | Composition, 68K | RC20BF683K |
| R23 | Composition, 2.2K 1W | RC30BF222K |
| R24 | Potentiometer, 250 K AM Level set | R50160-3 |
| R25, 26 | Composition, 1K | RC20BF102K |
| R27 | Composition, 180 | RC20BF181K |
| R28 | Composition, 27K | RC20BF273K |
| R29 | Composition, 150 | RC20BF151K |
| R30 | Composition, 1K | RC20BF102K |
| R31 | Composition, 47K | RC20BF473K |
| R32 | Composition, 1M | RC20BF105K |
| R33 | Composition, 39K | RC20BF393K |
| R34 | Composition, 82K | RC20BF823K |
| R35 | Composition, 1K | RC20BF102K |
| R36 | Composition, 3.3M | RC20BF335K |
| R37 | Composition, 2.2M | RC20BF225K |
| R38 | Composition, 47K | RC20BF473K |
| R39 | Composition, 470K | RC20BF474K |
| R40 | Composition, 68K | RC20BF683K |
| R41 | Composition, 82K | RC20BF823K |
| R42 | Composition, 1K | RC20BF102K |
| R43 | Composition, 270 | RC20BF271K |
| R44 | Composition, 56K | RC20BF563K |
| R45 | Composition, 68K | RC20BF683K |
| R46 | Potentiometer, 100 K MPX Balance | R50160-20 |
| R47 | Composition, 10M | RC20BF106K |
| R48 | Composition, 68K | RC20BF683K |
| R49 | Composition, 1.5K | RC20BF152K |
| R50 | Composition, 1K | RC20BF102K |
| R51 | Composition, 470K | RC20BF474K |
| R52, 53 | Composition, 6.8K | RC20BF682K |
| R54 | Composition, 180K | RC20BF184K |
| R55 | Composition, 1.2M | RC20BF125K |
| R56, 57 | Composition, 47K | RC20BF473K |
| R58 | Composition, 10K | RC20BF103K |
| R59 | Composition, 10 | RC20BF100K |
| R60 | Composition, 10K | RC20BF103K |
| R61 | Composition, 10 | RC20BF100K |
| R62, 63 | Composition, 2.7K, 1W | RC30BF272K |
| R64, 65 | Composition, 330K, 1W | RC30BF334K |
| R66, 67 | Composition, 4.7M | RC20BF475K |
| R68, 69 | Composition, 220K | RC20BF224K |
| R70 | Potentiometer, 250K, Phono A level set | R50160-3 |
| R71, 72 | Composition, 470K | RC20BF474K |
| R73 | Composition, 3.3M | RC20BF335K |
| R74 | Composition, 2.2M | RC20BF225K |
| R75 | Composition, 3.3M | RC20BF335K |
| R76 | Composition, 2.2M | RC20BF225K |
| R77 | Composition, 100K | RC20BF104K |
| R78 | Composition, 560 | RC20BF561K |
| R79 | Composition, 100K | RC20BF104K |
| R80 | Composition, 560 | RC20BF561K |
| R81, 82 | Composition, 220K | RC20BF224K |
| R83 | Potentiometer, dual 1M treble | R50106-34 |
| R84 | Composition, 220K | RC20BF224K |
| R85 | Potentiometer, dual 1M bass | R50160-35 |
| R86 | Composition, 15K | RC20BF153K |
| R87 | Composition, 220K | RC20BF224K |
| R88 | Composition, 15K | RC20BF153K |
| R89, 90 | Composition, 39K | RC20BF393K |
| R91 | Composition, 10M | RC20BF106K |
| R92 | Composition, 470K | RC20BF474K |

| | | |
|-----------|--|------------|
| R93 | Composition, 10M | RC20BF106K |
| R94 | Composition, 470K | RC20BF474K |
| R95, 96 | Composition, 4.7M | RC20BF475K |
| R97, 98 | Composition, 2.2M | RC20BF225K |
| R99, 100 | Composition, 220K | RC20BF224K |
| R101 | Composition, 100K | RC20BF104K |
| R102 | Composition, 560 | RC20BF561K |
| R103 | Composition, 100K | RC20BF104K |
| R104 | Composition, 560 | RC20BF561K |
| R105 | Potentiometer, dual 250 K balance | R50160-33 |
| R106, 107 | Composition, 3.3M | RC20BF335K |
| R108 | Composition, 22M | RC20BF226K |
| R109 | Composition, 330K | RC20BF334K |
| R110 | Potentiometer, dual 500 K volume | R50160-32 |
| R111 | Composition, 22M | RC20BF226K |
| R112 | Composition, 330K | RC20BF334K |
| R113, 114 | Composition, 100K | RC20BF104K |
| R115, 116 | Composition, 22K | RC20BF223K |
| R117 | Composition, 220K | RC20BF224K |
| R118 | Composition, 470K | RC20BF474K |
| R119 | Composition, 10K | RC20BF103K |
| R120 | Composition, 1K | RC20BF102K |
| R121 | Wirewound, 270, 5W | R684-141 |
| R122 | Wirewound, 330, 5W | R746-146 |
| R123 | Wirewound, 30, 5W | R689-103 |
| R124, 125 | Composition, 220 | RC20BF221K |
| R126 | Composition, 220K | RC20BF224K |
| R127 | Potentiometer, 250 K Phono B level set | R50160-3 |
| R128 | Composition, 470K | RC20BF474K |

COILS, CHOKES, AND TRANSFORMERS

| Symbol | Description | Part No. |
|---------|--------------------------------|-----------|
| L1 | Coil, FM Antenna | L726-124 |
| L2 | Coil, AM Antenna | L721-139 |
| L3 | AM Ferrite loop | L721-136 |
| L4 | Choke, 1 Micro Henry | L50066-2 |
| L5, 6 | Choke, 56 Micro Henries | L50066-19 |
| L7 | Choke, RF | L629-180 |
| L8 | Coil, FM RF. | L726-126 |
| L9 | Coil, FM Osc. | L726-125 |
| L10 | Choke, 1 Micro Henry | L50066-2 |
| L11 | Choke, .56 Micro Henries | L50066-19 |
| L12 | Choke, 1 Micro Henry | L50066-2 |
| L13 | Coil, AM Osc. | L50210-21 |
| L14 | Choke, 1.2 Micro Henries | L50066-3 |
| L15 | Coil, 10KC Filter | L644-120 |
| L16 | Choke, 3.3 Micro Henries | L50066-8 |
| L17, 18 | Choke Filament Ferrite Bead | L592-189 |
| L19 | Choke, 1.2 Micro Henries | L50066-3 |
| T1 | Transformer, Power | T755-115 |
| Z1 | Transformer, FM IF | ZZ662-117 |
| Z2 | Transformer, FM IF | ZZ2987 |
| Z3 | Coil, FM Limiter | L670-145 |
| Z4 | Transformer, FM Radio Detector | ZZ592-170 |
| Z5 | Transformer, AM RF | L556-125 |
| Z6 | Transformer, AM IF | ZZ50210-1 |
| Z7 | Transformer, AM IF | ZZ2984 |

MISCELLANEOUS

| Symbol | Description | Part No. |
|----------------|------------------|--------------|
| F1 | Fuse, 2 Amp. | F755-145 |
| 11, 12 | Lamp, Dial Panel | L50082-3 |
| S1 | Switch, Selector | S755-116 |
| S2, 3, 4, 5, 6 | Switch, Slide | S50200-2 |
| S7 | Switch, Loudness | Part of R110 |
| S8 | Switch, Power | Part of R110 |

ALIGNMENT INSTRUCTIONS

Read These Instructions With Extreme Care Before Attempting Alignment.

CHASSIS: Turn the station selectors completely counterclockwise, without forcing. Dial pointers should be at zero index mark on logging scale. If not, reset the dial pointers. Disconnect the external antennas and the antenna link. Set Ferrite Loop to normal position, parallel to rear panel. When using an oscilloscope for alignment, set the output level controls for no overload, as shown by the proper waveform shape.

SIGNAL GENERATORS: The signal generator equipment must be able to supply the following: FM RF modulated 30% (± 22.5 KC deviation) at 400 cps; AM RF modulated 30% at 400 cps;

AM IF with 30KC sweep for AM bandwidth adjustment; audio oscillator accurately calibrated for 1 and 10KC audio output for testing the 10KC AM whistle filter.

INDICATOR: DC VTVM, AC VTVM, and scope for alignment. AC VTVM for 10 KC AM whistle filter adjustment.

ALIGNMENT: Allow the chassis and test instruments to warm up for at least fifteen minutes. Adjust the line voltage for 117 volts AC, 50-60 cycles. Use fully insulated tools: a small screwdriver for all trimming capacitors; a K-Tran tool for Z1, Z2, Z3, Z5, Z6 and Z7; a hex tool for Z4, L1, L8 and L9. For AM alignment, short test point 4 to ground.

AM ALIGNMENT

| STEPS | CHASSIS | | | SIGNAL GENERATOR | | | INDICATOR | | ALIGNMENT | |
|---|---|----------|--|--|---------------|----------------------------------|---|------------|---------------------------------|---|
| | AM BANDWIDTH | SELECTOR | STATION SELECTOR | COUPLING | FREQ. | MOD. | TYPE | CONNECTION | ADJUST | INDICATION |
| 1 | SHARP | AM | Point of no signal and no interference | Audio Gen. connected to Pin 7 of V9 | 1 KC 10 KC | None | AC VTVM to Ch. A RCRDR Output | | | 0 db at 1 KC — 25 db at 10 KC |
| 2 | SHARP | AM | Point of no signal and no interference | AM Gen. connected thru .01-uf cap. in series with hot lead to V8, Pin 2 | 455 KC | 30% AM at 400 cps | AC VTVM to Ch. A RCRDR Output | | Z6, Z7 top and bottom | Maximum voltage |
| 3 | BROAD | AM | Point of no signal and no interference | AM Gen. connected thru .01-uf cap. in series with hot lead to V8, Pin 2 | 455 KC | 30 KC sweep | Scope to Ch. A RCRDR Output | | Z6 Bottom | Adjust slightly for symmetrical curve |
| 4 | SHARP | AM | 600 KC | AM Gen. connected thru 220-uf cap. in series with hot lead to antenna terminal 3 Disconnect link between 1 & 2 | 600 KC | 30% AM at 400 cps | AC VTVM to Ch. A RCRDR Output | | L13, Z5 | Maximum voltage |
| 5 | SHARP | AM | 1400 KC | AM Gen. connected thru 220-uf cap. in series with hot lead to antenna terminal 3 Disconnect link between 1 & 2 | 1400 KC | 30% AM at 400 cps | AC VTVM to Ch. A RCRDR Output | | C7E, C7C, C7A | Maximum voltage |
| 6 | Repeat steps 4 and 5 for proper dial calibration and maximum output. | | | | | | | | | |
| 7 | | FM | Point of no signal and no interference | FM Gen. connected to ungrounded tube shield of V2 | 10.7 MC | None | DC VTVM to test point 1 | | Z1, Z2, Z3 and Z4, top & bottom | Maximum negative voltage |
| 8 | | FM | Point of no signal and no interference | FM Gen. connected to ungrounded tube shield of V2 | 10.7 MC | None | Connect VT VM to test point 2 | | Z4 top | Zero reading on zero center scale |
| 9 | | FM | 90 MC | FM Gen. connected thru two 120-ohm carbon resistors in series with lead to antenna terminals 4 and 5 | 90 MC | 30% FM (22.5 KC Dev.) at 400 cps | DC VTVM to the junction of R32 and R36 and scope to Ch. A. RCRDR Output | | L1, L8 and L9 | Check for sine waveform and adjust for maximum negative voltage |
| 10 | | FM | 106 MC | FM Gen. connected thru two 120-ohm carbon resistors in series with lead to antenna terminals 4 and 5 | 106 MC | 30% FM (22.5 KC Dev.) at 400 cps | DC VTVM to the junction of R32 and R36 and scope to Ch. A. RCRDR Output | | C5, C22 and C32 | Check for sine waveform and adjust for maximum negative voltage |
| 11 | Repeat steps 9 and 10 at least once for proper dial calibration and maximum output. | | | | | | | | | |
| NOTE: For calibrating both the AM and FM, use as low an output voltage as possible from your signal generator. | | | | | | | | | | |

FM ALIGNMENT

SCHEMATIC DIAGRAM • FM-AM TUNING SECTIONS

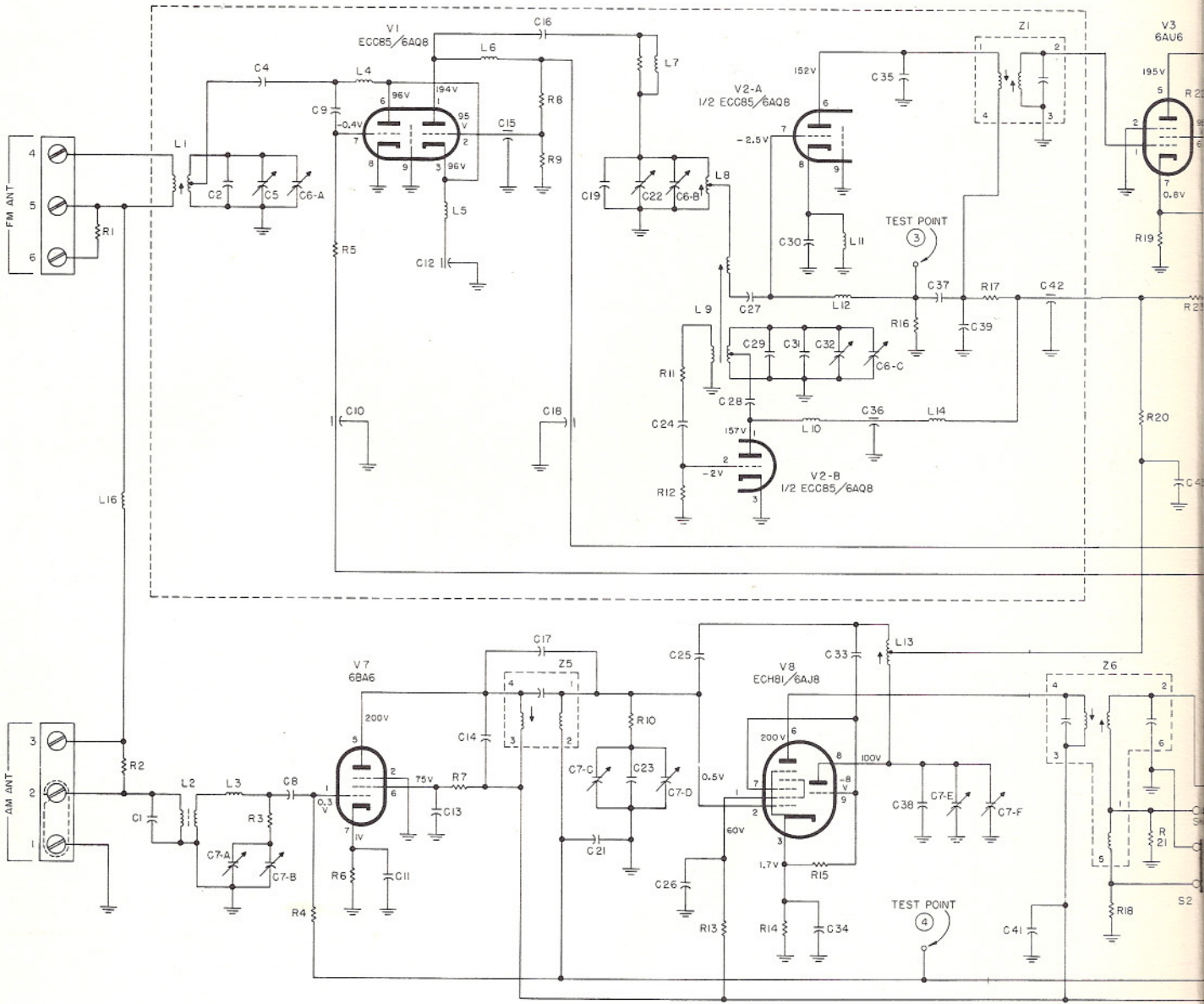

S1
SELECTOR SWITCH
POSITIONS

SHOWN IN — MONO PHONO
PHONO STEREO
AM
FM
FM-AM
FM-MPX
FM-FM
AUX STEREO
AUX MONO

| RESISTORS | R1 | R2 | R3 | R4 | R5 R6 | R7 | R8 R9 | R10 R11 | R13 | R14 | R15 | R16 | R17 | R18 | R19 R20 R21 | R22 R23 R24 | | | | |
|------------|----|------------|----------|--------------------|-----------|-------------------|------------|-------------------|------------|--------------------|--------------------|------------|-------------------|------------|-------------------|--------------------|------------|-------------|-------------|------------|
| CAPACITORS | C1 | C2 C7-A | C4 C5 | C6-A C7-B C8 | C9 C10 | C11 C12 C13 | C14 C15 | C16 C17 C18 | C19 C21 | C22 C7-C C23 | C24 C6-B C26 | C25 C26 | C27 C28 C29 | C30 C31 | C32 C33 C34 | C35 C36 C6-C | C37 C38 | C39 C7-E | C7-F C41 | C42 C43 |

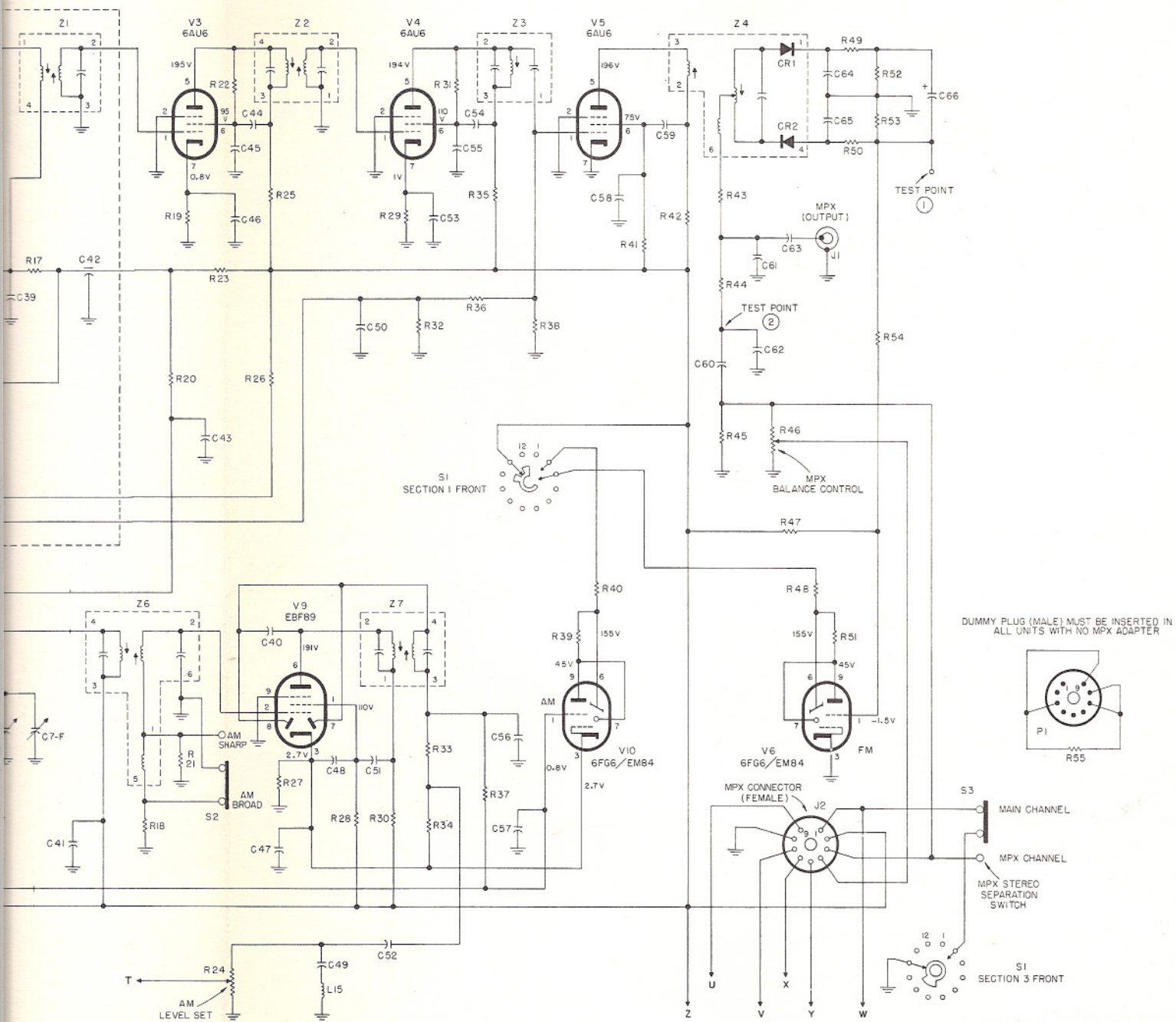

DUMMY PLUG (MALE) MUST BE INSERTED IN ALL UNITS WITH NO MPX ADAPTER

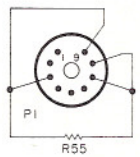

P 755 SCHEMATIC AW #1650 SHEET 1 OF 2

| | | | | | | | | | | | | | | | | | | |
|------|-----|-----|-----|-----|-----|-----|-----|-----|-----|-----|-----|-----|-----|-----|-----|-----|-----|-----|
| R17 | R18 | R19 | R22 | R25 | R28 | R29 | R31 | R35 | R38 | R39 | R40 | R41 | R42 | R43 | R46 | R49 | R52 | R55 |
| | R20 | R21 | R23 | R26 | | R30 | TO | R36 | | | | | | R44 | R47 | R50 | R53 | |
| | | | R24 | R27 | | | R34 | R37 | | | | | | R45 | R48 | R51 | R54 | |
| C7-F | C41 | C43 | C44 | C47 | C48 | C50 | C53 | C54 | C56 | C58 | C59 | C60 | C61 | C63 | C64 | C65 | C66 | |
| | C42 | | C45 | C40 | C49 | C51 | C52 | C55 | C57 | | | | C62 | | C66 | | | |

SCHEMATIC DIAGRAM • PREAMPLIFIER

Ma
Ch

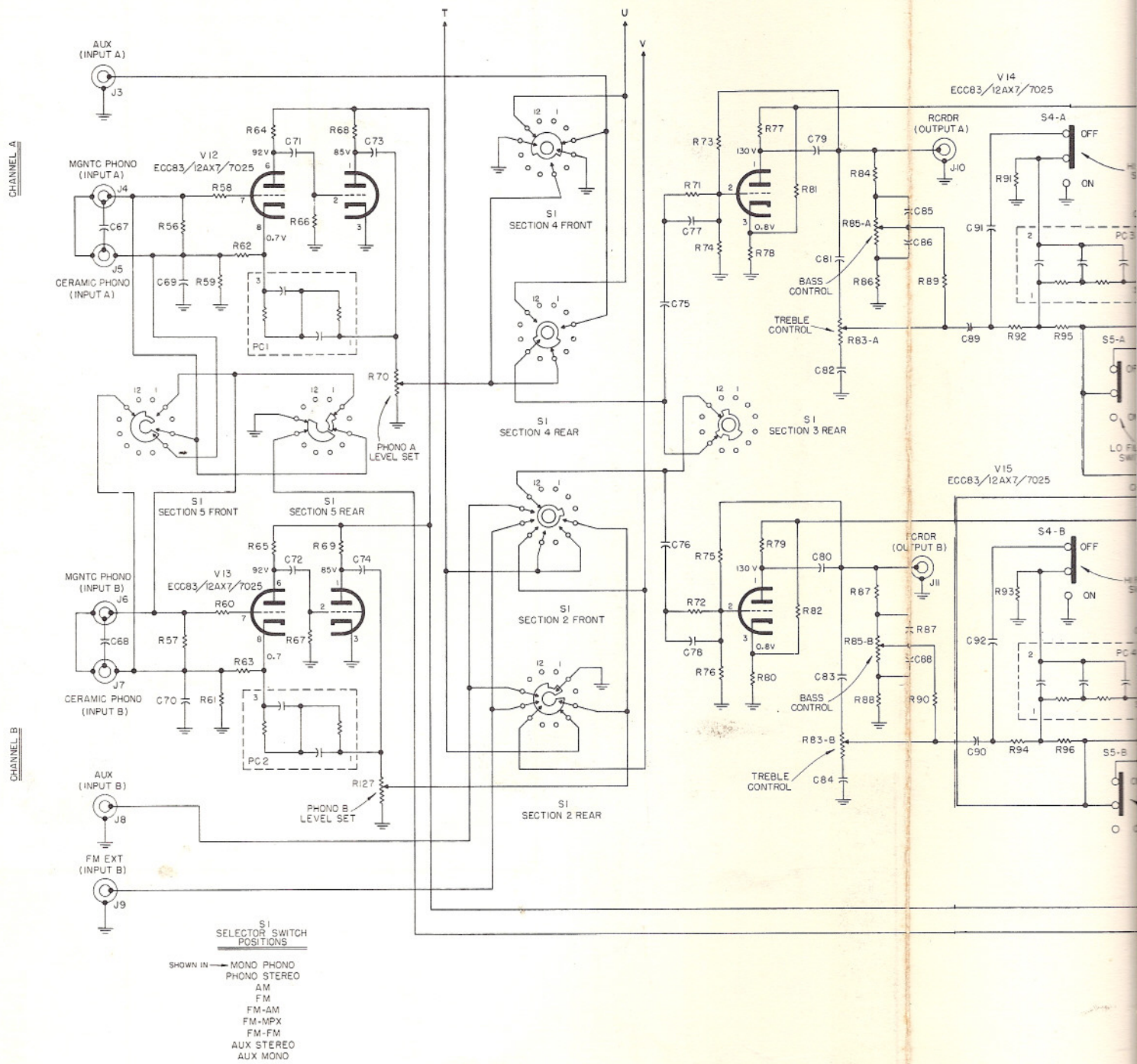

| | | | | | | | | | | | | | | | | |
|------------|------------|------------------|------------|------------|------------|------------|-------------|------------|------------------|------------------|------------|----------------|------------------|------------|------------------|------------|
| RESISTORS | R56 R57 | R58 TO R61 | R62 R63 | R64 R65 | R66 R67 | R68 R69 | R70 R127 | R71 R72 | R73 TO R76 | R77 TO R80 | R81 R82 | R83-A R83-B | R84 TO R88 | R89 R90 | R91 TO R94 | R95 R96 |
| CAPACITORS | C67 C68 | C69 C70 | | C71 C72 | | C73 C74 | | C75 C76 | C77 C78 | | C79 C80 | C81 C84 | C85 TO C88 | C89 C90 | C91 C92 | |

Mod. 808
Chassis 100 - T

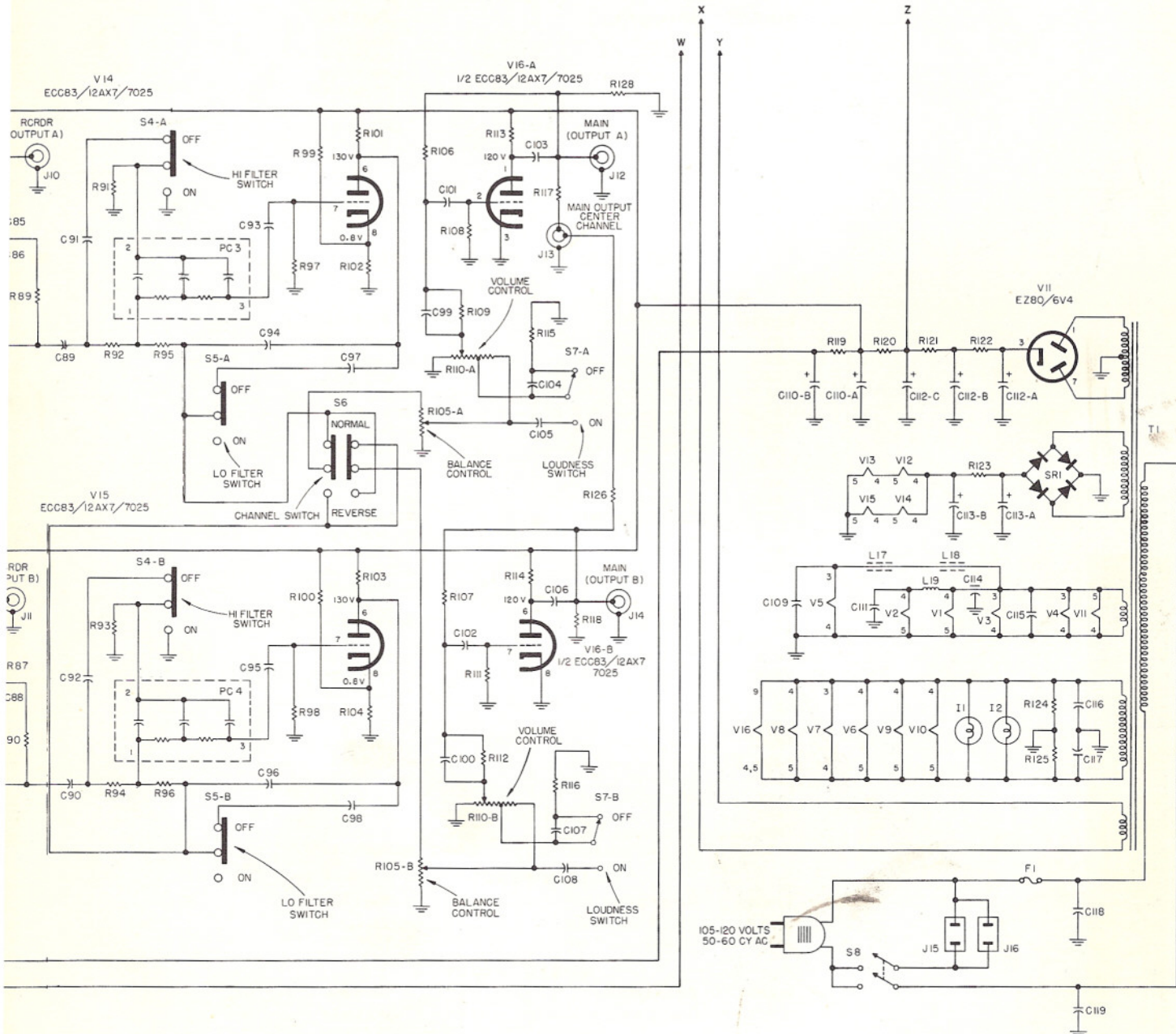

P 755 SCHEMATIC AW # 1650
SHEET 2 OF 2

| | | | | | | | | | | | | | | | |
|------------|------------------|------------|------------------|-------------|--------------------|------------------|--------------------|----------------------|----------------------|--------------|------|--------------------------|----------------------------|--------------|--------------------|
| R89 R90 | R91 TO R94 | R95 R96 | R97 R98 | R99 R100 | R101 TO R104 | R105-A R105-B | R106 TO R112 | R113 R114 R115 | R116 R117 R118 | R126 R128 | R119 | R120 | R121 | R122 R123 | R124 R125 |
| C89 C90 | C91 C92 | | C93 TO C96 | C97 C98 | C99 TO C100 | C101 C102 | C103 TO C108 | | | | C109 | C110-B C110-A C111 | C112-C C112-B C113-B | C115 C114 | C116 TO C119 |

SCHEMATIC DIAGRAM • AMPLIFIER SA-16

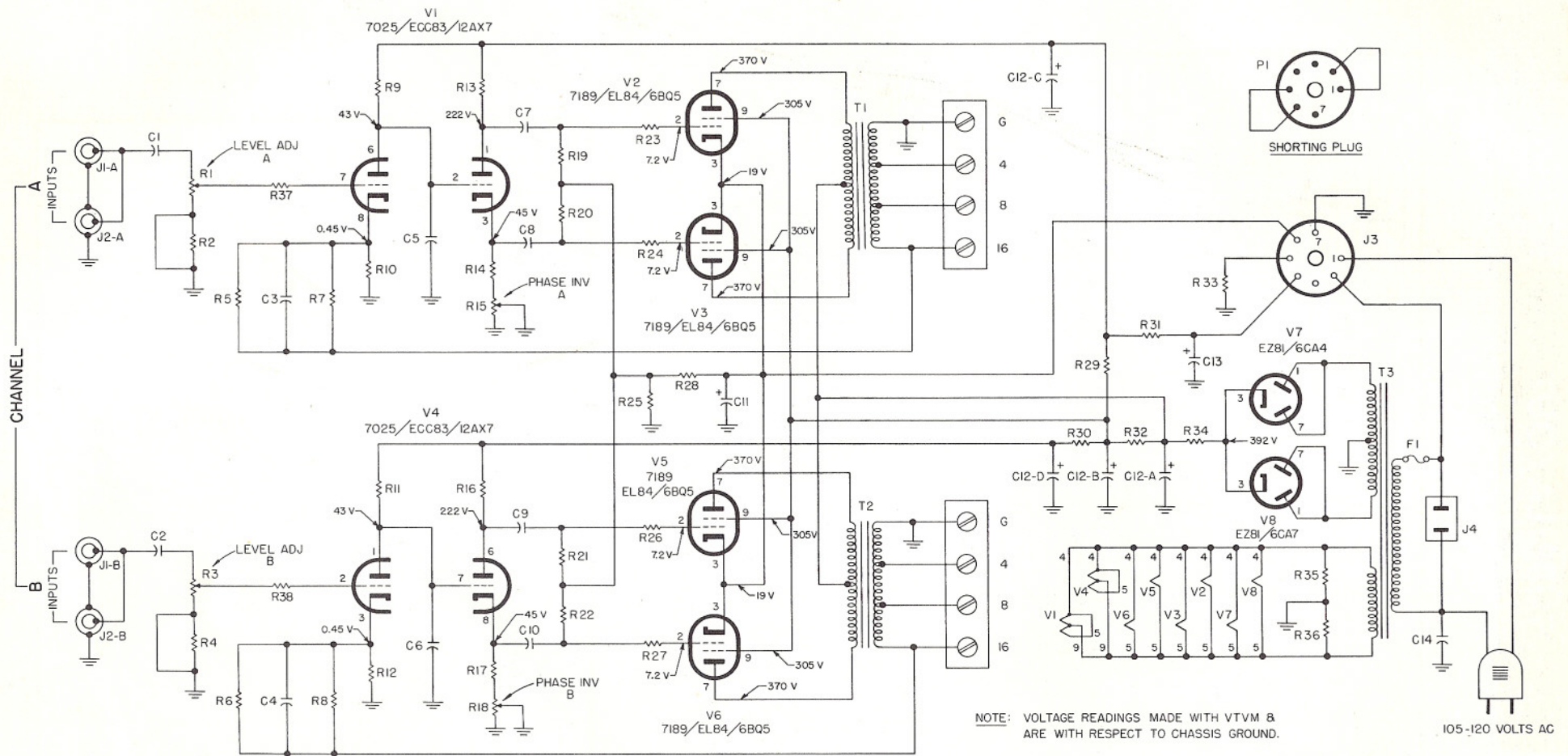

NOTE: VOLTAGE READINGS MADE WITH VTVM & ARE WITH RESPECT TO CHASSIS GROUND.

P754 SCHEMATIC AW #1637

PHASE INVERTER BALANCE ADJUSTMENT

The phase inverter balance adjustments for Channel A and Channel B are located on the top surface of the SA-16 chassis. These adjustments should not be attempted unless you have a harmonic distortion analyzer and audio generator; or intermodulation analyzer. Make adjustments as follows:

1. Connect the audio generator to an input of the appropriate channel on the SA-16.
2. Load the output of the amplifier and connect the analyzer across the load.

3. If you are using a harmonic distortion analyzer, set the audio generator to 1000 cps. If you are using an intermodulation analyzer, connect its output to the input of the SA-16. Adjust the input signal to the SA-16 so that its output is just below the clipping point (about 1 db below.)

4. Keeping this output constant, adjust the phase inverter balance control (R15 or R18) for minimum distortion on the analyzer.

TUBE LAYOUT

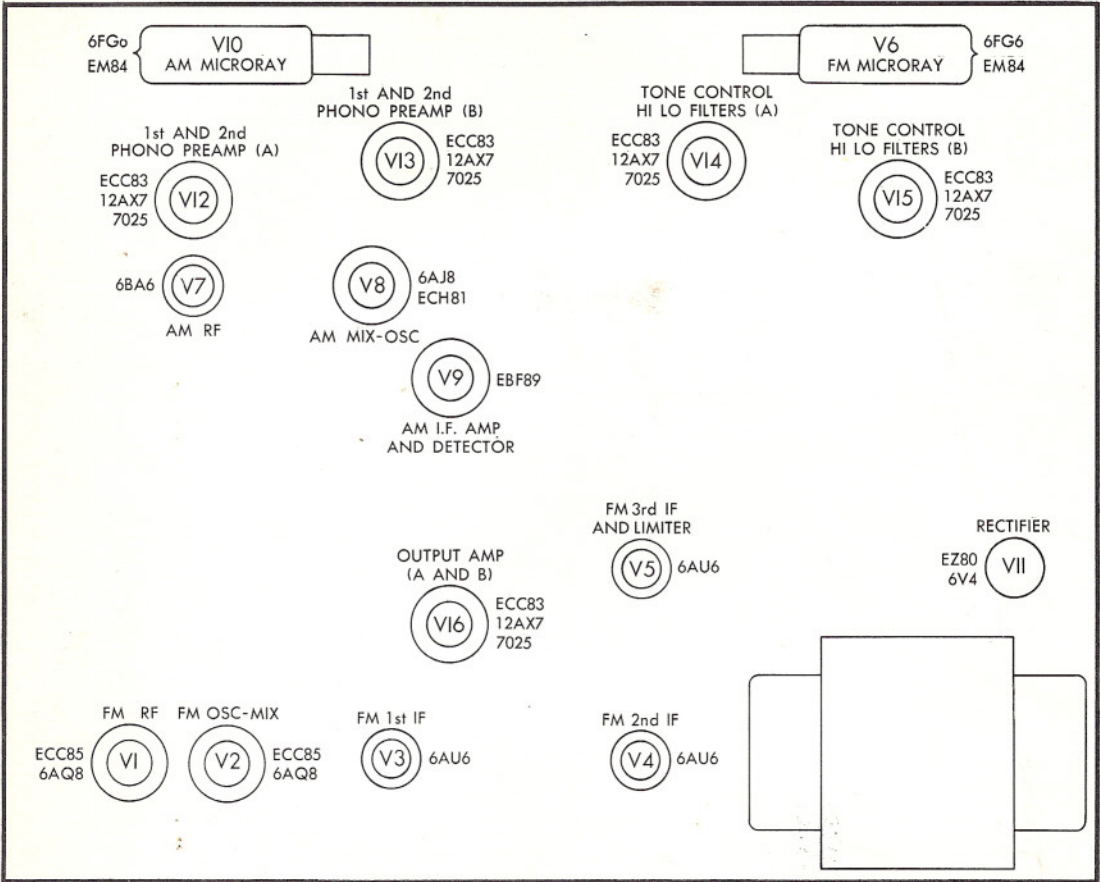

AW 1655

TUNERS AND PREAMPLIFIER

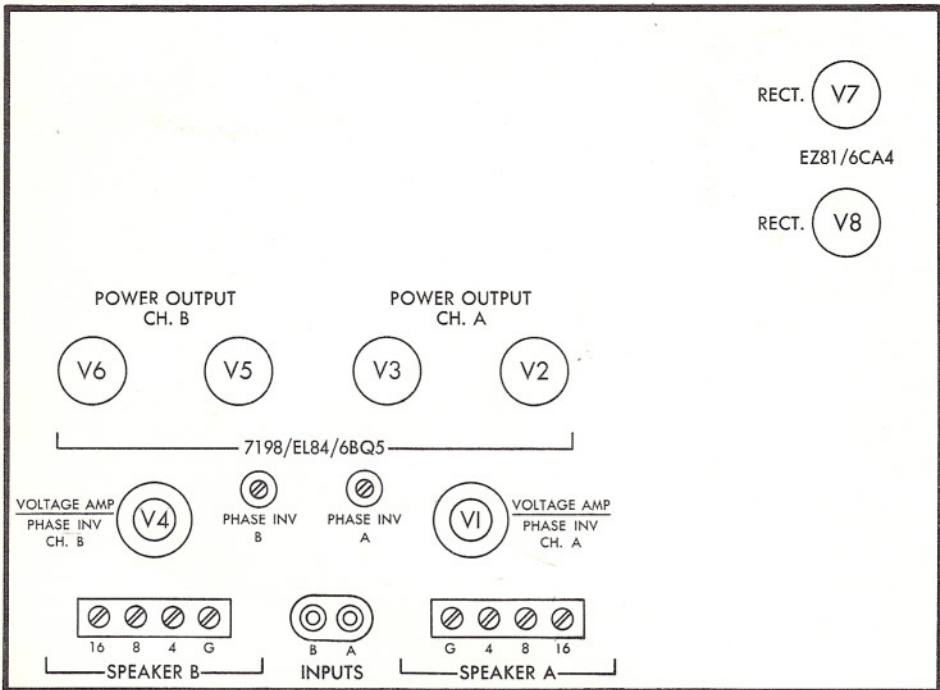

AW 1666

AMPLIFIER SA-16

CAPACITORS

10% tolerance for all fixed capacitors, unless otherwise noted or marked GMV (guaranteed minimum value.)

| Symbol | Description | Part No. |
|--------------|--|-----------|
| C1, 2 | Ceramic, .02uf 20%, 500V | C50089-5 |
| C3, 4 | Ceramic, 47uuf N750, 1000V | C50070-4 |
| C5, 6 | Ceramic, 220uuf, 1000V | C50072-20 |
| C7, 8, 9, 10 | Ceramic, .02uf 20%, 500V | C50089-5 |
| C11 | Electrolytic, 100uf, 100V | C663-143 |
| C12 | Electrolytic, four sections: A: 40uf, 450V B: 40uf, 400V C: 40uf, 350V D: 40uf, 350V | C50180-11 |
| C13 | Electrolytic, 10uf, 350V | C644-146 |
| C14 | Molded, .01uf 20%, 600V | C2747 |

RESISTORS AND POTENTIOMETERS

In ohms, 10% tolerance, 1/2 watt, unless otherwise noted. K = kilohm, M = megohm.

| Symbol | Description | Part No. |
|-------------------|----------------------|------------|
| R1 | Potentiometer, 500K | R50103-6 |
| R2 | Composition, 1M | RC20BF105K |
| R3 | Potentiometer, 500K | R50103-6 |
| R4 | Composition, 1M | RC20BF105K |
| R5, 6 | Composition, 91K, 5% | RC20BF913J |
| R7, 8 | Composition, 39K | RC20BF393K |
| R9 | Composition, 680K | RC20BF684K |
| R10 | Composition, 1.5K | RC20BF152K |
| R11 | Composition, 680K | RC20BF684K |
| R12 | Composition, 1.5K | RC20BF152K |
| R13 | Composition, 82K | RC20BF823K |
| R14 | Composition, 56K | RC20BF563K |
| R15 | Potentiometer, 50K | R50103-3 |
| R16 | Composition, 82K | RC20BF823K |
| R17 | Composition, 56K | RC20BF563K |
| R18 | Potentiometer, 50K | R50103-3 |
| R19, 20 21, 22 | Composition, 820K | RC20BF824K |
| R23 | Composition, 2.2K | RC20BF222K |
| R24 | Composition, 33K | RC20BF333K |
| R25 | Composition, 6.8K | RC20BF682K |
| R26 | Composition, 2.2K | RC20BF222K |
| R27 | Composition, 33K | RC20BF333K |
| R28 | Composition, 10K | RC20BF103K |
| R29, 30 | Composition, 22K | RC20BF223K |
| R31 | Composition, 3.9K | RC20BF392K |
| R32 | Wirewound, 3.5K, 7W | R754-122 |
| R33 | Wirewound, 125, 7W | R556-124 |
| R34 | Wirewound, 100, 10W | R754-121 |
| R35 | Composition, 220 | RC20BF221K |

TRANSFORMERS

| Symbol | Description | Part No. |
|--------|---------------------|------------|
| T1, 2 | Transformer, Output | T725-116-1 |
| T3 | Transformer, Power | T754-115 |

MISCELLANEOUS

| Symbol | Description | Part No. |
|--------|-------------------------|----------|
| F1 | Fuse, 2 Ampere, Slo-Blo | F643-154 |

SCHEMATIC DIAGRAM • SPEAKER SYSTEMS

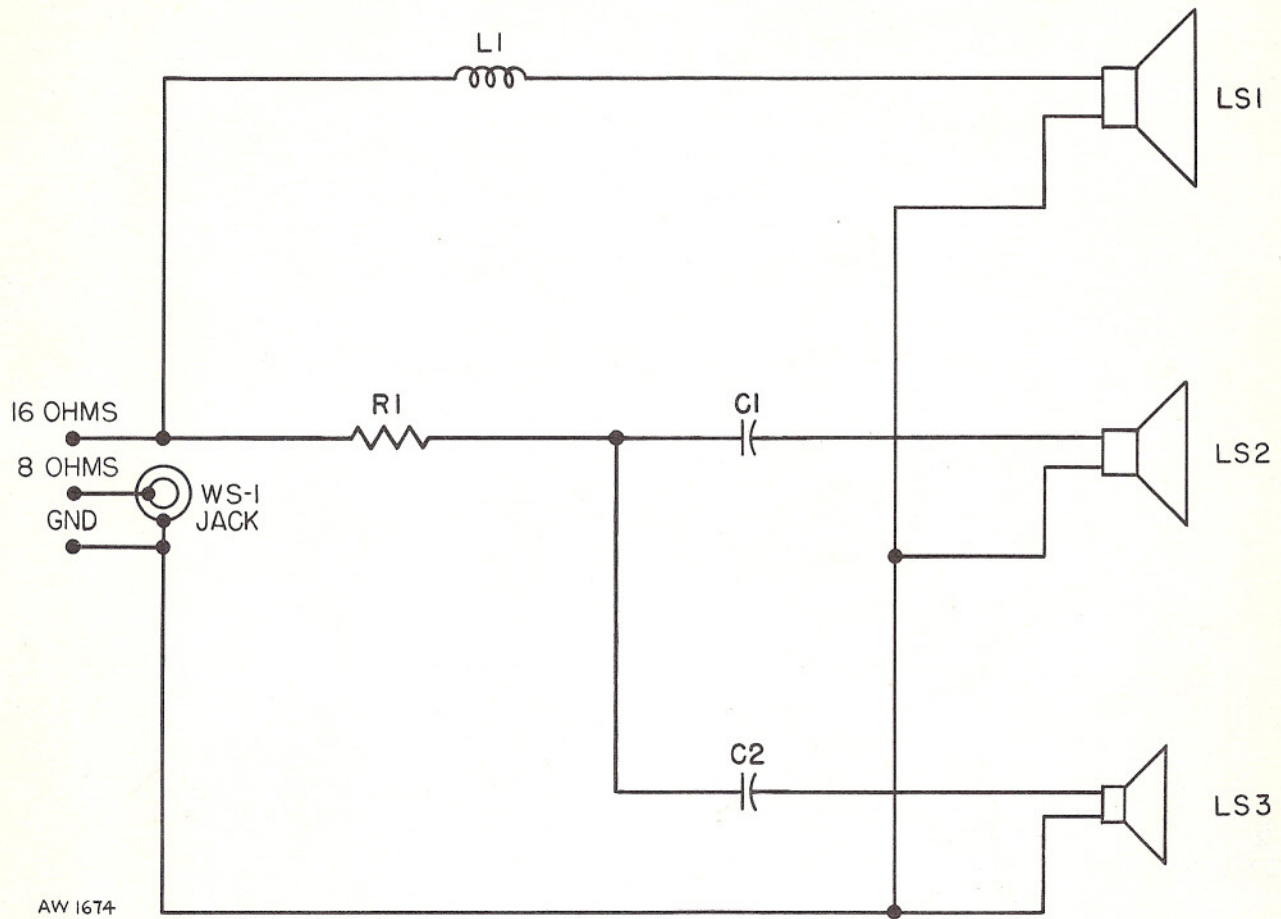

PARTS DESCRIPTION LIST • SPEAKER SYSTEMS

| Symbol | Description | Part No. |
|--------|--|------------|
| C1 | Electrolytic, non-polarized, 16uf, 50V | C765-107 |
| C2 | Paper, 2uf, 50V | C547-118 |
| R1 | Wire-wound, 4 ohms, 5 watt | R788-107 |
| L1 | Coil, crossover, 3 mh | L547-120 |
| LS1 | Speaker, 12-inch, woofer, 16 ohms | LS-765-106 |
| LS24 | Speaker, 8-inch, mid-range, 16 ohms | LS-50123 |
| LS3 | Speaker, tweeter, 16 ohms | LS-547-124 |

NOTE: In earlier models, R1 is 10 ohms, 5 watts R779-103
 LS1 is LS-688-113



FISHER RADIO CORPORATION • NEW YORK

